

**Standard EEPROMs  
Plug & Play EEPROMs  
(for Display)**



# BR24C21xxx Series (1K)

● **General Description**

BR24C21F, BR24C21FJ, BR24C21FV are serial EEPROMs that support DDC1™/DDC2™ interfaces for Plug and Play displays

● **Features**

- Compatible with both DDC1™/DDC2™
- Operating voltage range: 2.5V to 5.5V
- Page write function: 8bytes
- Low power consumption
  - Active (at 5V) : 1.5mA (typ)
  - Stand-by (at 5V) : 0.1μA (typ)
- Address auto increment function during Read operation
- Data security
  - Write enable feature (VCLK)
  - Write protection at low Vcc
- Initial data=FFh
- Data retention: 10years
- Rewriting possible up to 100,000 times

● **Packages W(Typ.) x D(Typ.) x H(Max.)**

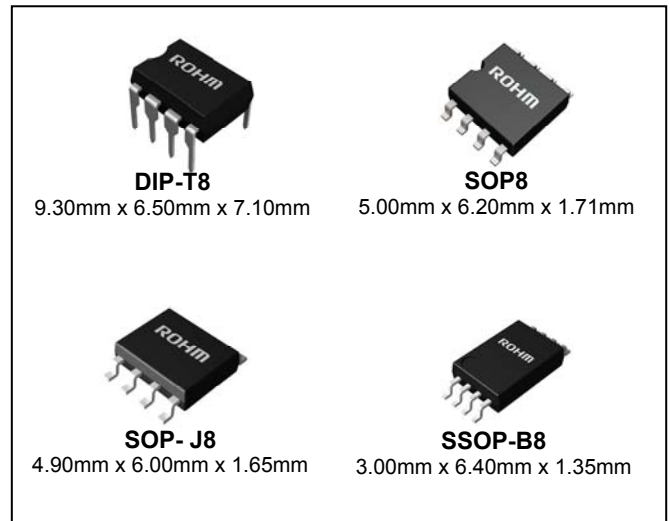

● **BR24C21xxx series**

Capacity	Type	Power source Voltage	DIP-T8	SOP8	SOP-J8	SSOP-B8
1Kbit	BR24C21	2.5V to 5.5V	●	●	●	●

● **Absolute Maximum Ratings**

Parameter	Symbol	Ratings	Unit	Remarks
Supply Voltage	V <sub>CC</sub>	-0.3 to +6.5	V	
Power Dissipation	Pd	800(DIP-T8)	mW	When using at Ta=25°C or higher 8.0mW to be reduced per 1°C.
		450 (SOP8)		When using at Ta=25°C or higher 4.5mW to be reduced per 1°C.
		450 (SOP-J8)		When using at Ta=25°C or higher 4.5mW to be reduced per 1°C.
		350(SSOP-B8)		When using at Ta=25°C or higher 3.5mW to be reduced per 1°C.
Storage Temperature	T <sub>stg</sub>	-65 to +125	°C	
Operating Temperature	T <sub>opr</sub>	-40 to +85	°C	
Terminal Voltage	-	-0.3 to V <sub>CC</sub> +0.3	V	

● **Memory cell characteristics**

Parameter	Limits			Unit
	Min.	Typ.	Max	
Write/Erase Cycle	100,000	—	—	Times
Data Retention	10	—	—	Years

○Product structure : Silicon monolithic integrated circuit ○This product is not designed protection against radioactive rays

### ● Recommended Operating Ratings

Parameter	Symbol	Ratings	Unit
Supply Voltage	V <sub>CC</sub>	2.5 to 5.5	V
Input voltage	V <sub>IN</sub>	0 to V <sub>CC</sub>	

### ● Electrical characteristics

DC (Unless otherwise specified, Ta=-40°C to +85°C, V<sub>CC</sub>=2.5V to 5.5V)

Parameter	Symbol	Limits			Unit	Condition
		Min.	Typ.	Max.		
"H" Input Voltage 1	V <sub>IH1</sub>	0.7V <sub>CC</sub>	-	-	V	SCL, SDA
"L" Input Voltage 1	V <sub>IL1</sub>	-	-	0.3V <sub>CC</sub>	V	SCL, SDA
"H" Input Voltage 2	V <sub>IH2</sub>	2.0	-	-	V	VCLK
"L" Input Voltage 2	V <sub>IL2</sub>	-	-	0.8	V	VCLK, V <sub>CC</sub> ≥ 4.0V
"L" Input Voltage 3	V <sub>IL3</sub>	-	-	0.2V <sub>CC</sub>	V	VCLK, V <sub>CC</sub> < 4.0V
"L" Output Voltage	V <sub>OL</sub>	-	-	0.4	V	SDA, IOL=3.0mA
Input Leakage Current	I <sub>LI</sub>	-1	-	1	μA	SCL, VCLK, V <sub>IN</sub> =0V to V <sub>CC</sub>
Output Leakage Current	I <sub>LO</sub>	-1	-	1	μA	SDA, V <sub>OUT</sub> =0V to V <sub>CC</sub>
Operating Current	I <sub>CC</sub>	-	-	3.0	mA	V <sub>CC</sub> =5.5V, fSCL=400kHz
Standby Current	I <sub>SB</sub>	-	10	100	μA	V <sub>CC</sub> =5.5V, SDA=SCL=V <sub>CC</sub> , VCLK=GND *1

\*1 Transmit-Only Mode - After power on, the BR24C21/F/FJ/FV is in Standby mode and does not provide the clock to the VCLK pin. After the clock is provided to VCLK, the device is switched from Standby to Transmit-Only Mode, and the operating current flows.  
Bi-directional Mode - The BR24C21/F/FJ/FV is in Standby mode after each command is performed.

AC (Unless otherwise specified, Ta=-40°C to +85°C, V<sub>CC</sub>=2.5V to 5.5V)

Parameter	Symbol	Fast-mode V <sub>CC</sub> =2.5V to 5.5V			Standard-mode V <sub>CC</sub> =2.5V to 5.5V			Unit
		Min.	Typ.	Max.	Min.	Typ.	Max.	
Clock Frequency	fSCL	-	-	400	-	-	100	kHz
Data Clock High Period	t <sub>HIGH</sub>	0.6	-	-	4.0	-	-	μs
Data Clock Low Period	t <sub>LOW</sub>	1.3	-	-	4.7	-	-	μs
SDA and SCL Rise Time	t <sub>R</sub>	-	-	0.3	-	-	1.0	μs
SDA and SCL Fall Time	t <sub>F</sub>	-	-	0.3	-	-	0.3	μs
Start Condition Hold Time	t <sub>HD:STA</sub>	0.6	-	-	4.0	-	-	μs
Start Condition Setup Time	t <sub>SU:STA</sub>	0.6	-	-	4.7	-	-	μs
Input Data Hold Time	t <sub>HD:DAT</sub>	0	-	-	0	-	-	ns
Input Data Setup Time	t <sub>SU:DAT</sub>	100	-	-	250	-	-	ns
Output Data Delay Time(SCL)	t <sub>PD</sub>	-	-	0.9	0.2	-	3.5	μs
Stop Condition Setup Time	t <sub>SU:STO</sub>	0.6	-	-	4.0	-	-	μs
Bus Free Time	t <sub>BUF</sub>	1.3	-	-	4.7	-	-	μs
Write Cycle Time	t <sub>WR</sub>	-	-	10	-	-	10	ms
Noise Spike Width (SDA and SCL)	t <sub>I</sub>	-	-	0.1	-	-	0.1	μs

AC OPERATING CHARACTERISTICS (Transmit-Only Mode)

Output Data Delay Time(VCLK)	t <sub>VPD</sub>	-	-	1.0	-	-	2.0	μs
VCLK High Period	t <sub>VHIGH</sub>	0.6	-	-	4.0	-	-	μs
VCLK Low Period	t <sub>VLOW</sub>	1.3	-	-	4.7	-	-	μs
VCLK Setup Time	t <sub>VSU</sub>	0	-	-	0	-	-	μs
VCLK Hold Time	t <sub>VHD</sub>	0.6	-	-	4.0	-	-	μs
Mode Transition Time	t <sub>VHZ</sub>	-	-	0.5	-	-	1.0	μs
Transmit-Only Powerup Time	t <sub>VPU</sub>	0	-	-	0	-	-	μs
Noise Spike Width (VCLK)	t <sub>VI</sub>	-	-	0.1	-	-	0.1	μs

●Block Diagram

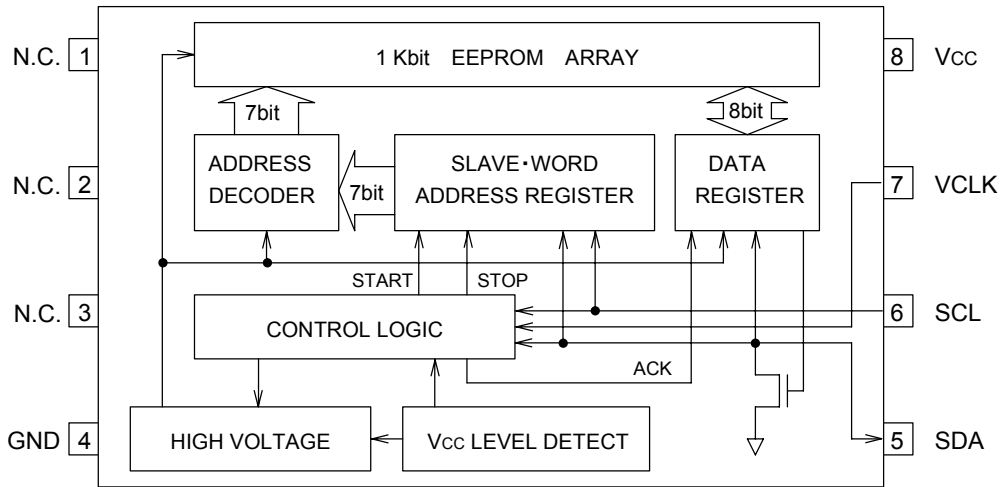

●Pin Configuration

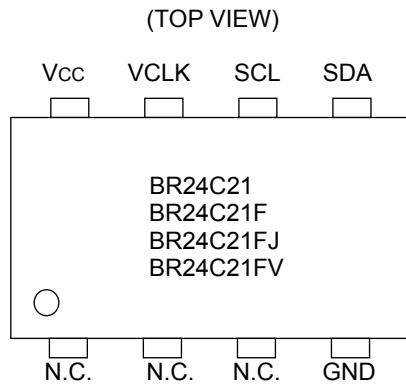

●Pin Descriptions

Pin Name	I/O	Functions
V <sub>CC</sub>	-	Power Supply
GND	-	Ground (0V)
N.C.	-	No Connection
SCL	IN	Serial Clock Input for Bi-directional Mode
SDA	IN/OUT	Slave and Word Address, Serial Data Input, Serial Data Output <sup>*1</sup>
VCLK	IN	Clock Input (Transmit-Only Mode) Write Enable (Bi-directional Mode)

\*1 An open drain output requires a pull-up resistor.

●Synchronous data timing

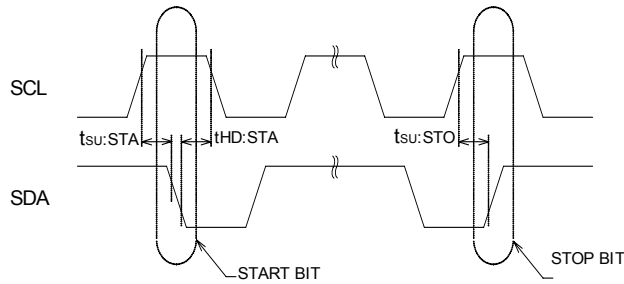
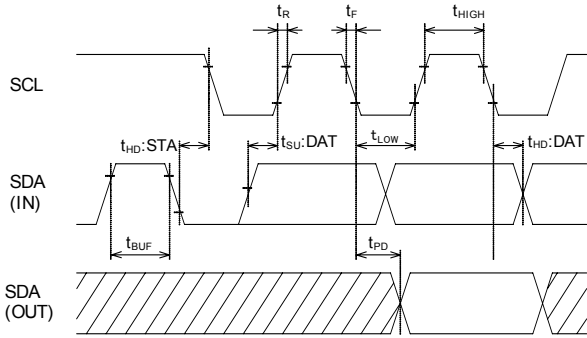

Figure 1. Synchronous Data Timing

- SDA data is latched into the chip at the rising edge of the SCL clock.
- Output data toggles at the falling edge of the SCL clock.

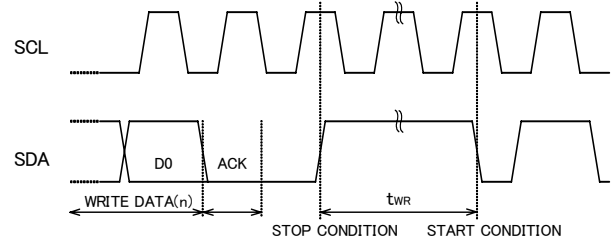

Figure 2. Write Cycle Timing

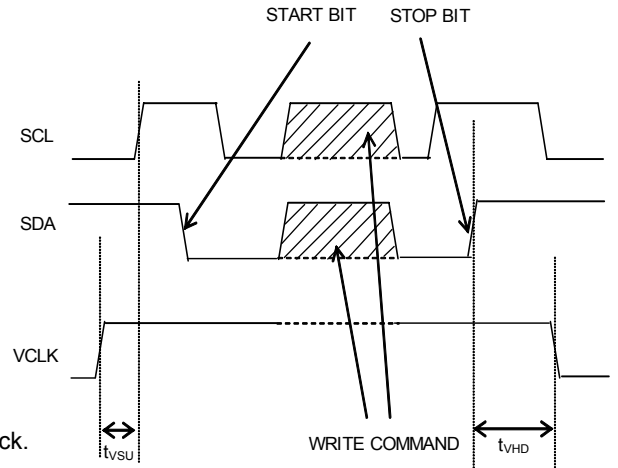

Figure 3. Write Enable Timing

●Transmit-only mode

- After power is on, the BR24C21/F/FJ/FV is in Transmit-Only Mode. In this mode data can be output by providing the clock to the VCLK pin.
- When the power is on, the SCL pin needs to be set to V<sub>CC</sub>(High level).
- SDA is at high-impedance during input of the first 9 clocks. At the 10th rising clock edge of VCLK data is output. After power on, the output data is as follows:  
00h address data → 01h address data → 02h address data → ...  
The address is incremented by one, after every 9 clocks of VCLK. All addresses are output in this mode. When the counter reaches the last address, the next output data is 00h address data. (See Figure 4.)
- In this mode, the NULL bit (High data) is output between the address data and the next address data. (See Figure 5.)
- The read operation is in Transmit-Only Mode and can be started after the power is stabilized.

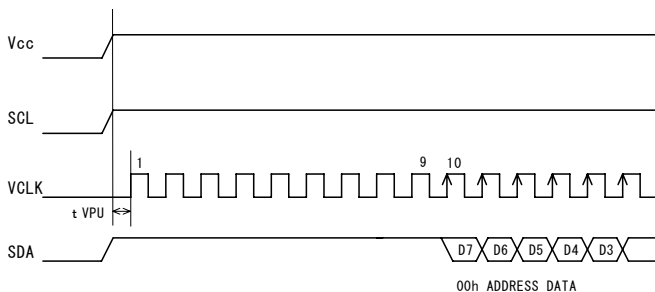

Figure 4. Transmit Only Mode

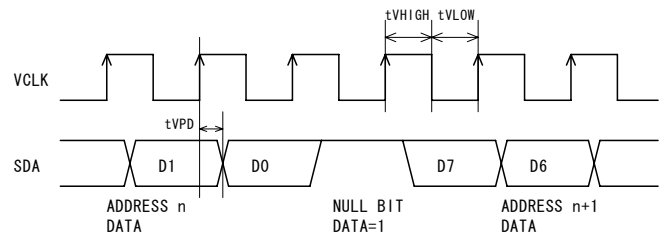

Figure 5. Null Bit



● Bidirectional mode command

○ Byte Write

When the Master generates a STOP condition, the BR24C21/F/FJ/FV begins the internal write cycle to the nonvolatile array.

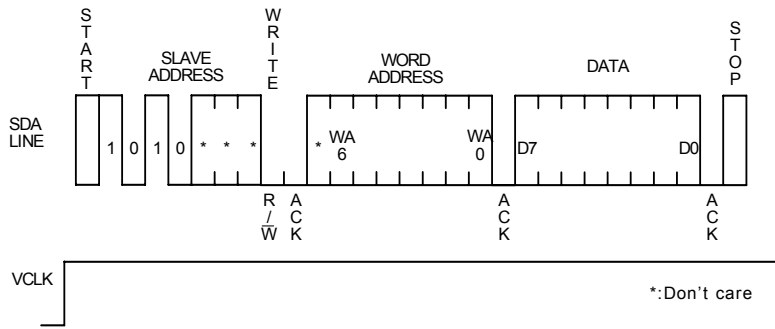

Figure 8. Byte Write Cycle Timing

○ Page Write

If the Master transmits the next data instead of generating a STOP condition during the byte write cycle, the BR24C21/F/FJ/FV transfers from byte write function to page write function. After receipt of each word, the three lower order address bits are internally incremented by one, while the high order four bits of the word address remains constant. If the master transmits more than eight words, prior to generating the STOP condition, the address counter will “roll over,” and the previous transmitted data will be overwritten.

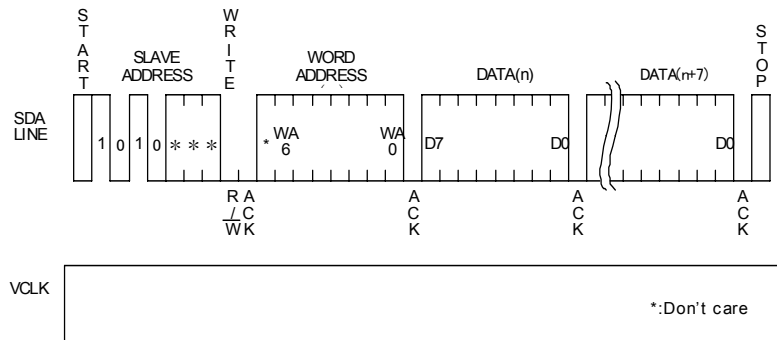

Figure 9. Page Write Cycle Timing

○ Current Read

The BR24C21/F/FJ/FV contains an internal address counter which maintains the address of the last word accessed, incremented by one. If the last accessed address is address “n” in a Read operation, the next Read operation will access data from address “n+1” and increment the current address counter. If the last accessed address is address “n” in a Write operation, the next Read operation will access data from address “n”. If the Master does not transfer an Acknowledge, but does generate a STOP condition, the current address read operation will only provide a single byte of data. At this point, the device discontinues transmission.

(See Figure 12 Sequential Read Cycle Timing)

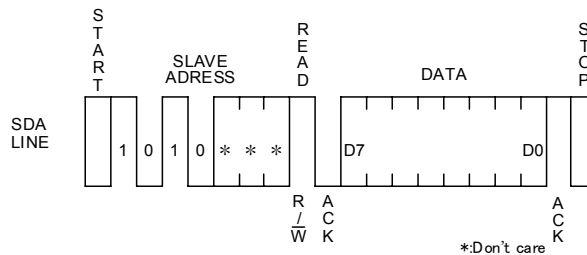

Figure 10. Current Read Cycle Timing

## ○Random Read

The Random read operation allows the Master to access any memory location. This operation involves a two-step process. First, the Master issues a Write command that includes the START condition and the Slave address field (with  $R/\overline{W}$  set to "0") followed by the word address of the word to be read. This procedure sets the internal address counter of the BR24C21/F/FJ/FV to the desired address. After the word address Acknowledge is received by the Master, the Master immediately re-issues a START condition followed by the Slave address field with  $R/\overline{W}$  set to "1." The device will respond with an Acknowledge and then transmit the 8-data bits stored at the addressed location. If the Master does not acknowledge the transmission but does generate the STOP condition, the IC will discontinue transmission.

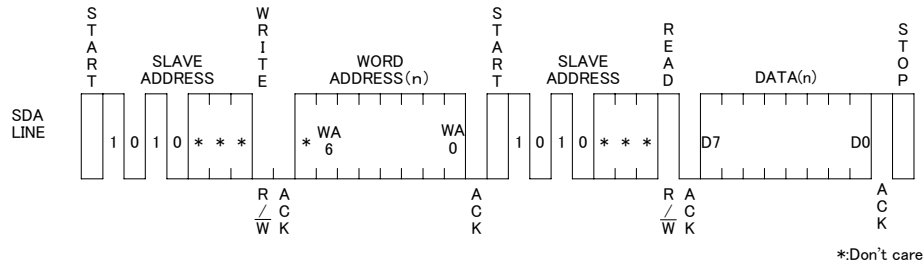
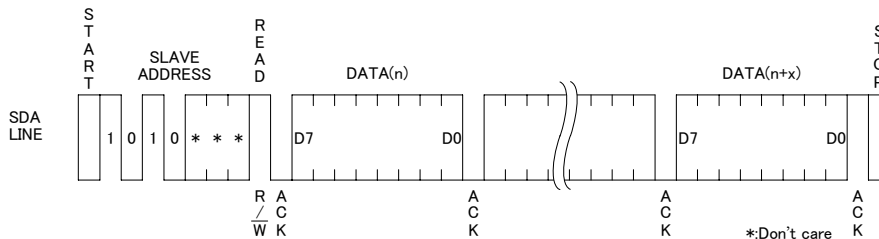

Figure 11. Random Read Cycle Timing

## ○Sequential Read

- If the Master does not transfer an Acknowledge and does not generate a STOP condition during the current Read operation, the BR24C21/F/FJ/FV continues to output the next address data in sequence. For Read operations, all bits in the address counter are incremented, allowing the entire array to be read during a single operation. When the counter reaches the top of the array, it will "roll over" to the bottom of the array and continue to transmit data.
- If the Master does not acknowledge the transmission but does generate a STOP condition, at this point the device discontinues transmission.
- The sequential Read operation can be performed with both Current Read and Random Read.

Figure 12. Sequential Read Cycle Timing  
(Current Read)

●Software Reset

Execute software reset in case the device is at an unexpected state after power up and/or the command input needs to be reset. The following figures (Figure 13-(a), Figure 13-(b), Figure 13-(c)) During dummy clock, please release SDA BUS (tied to Vcc by pull up resistor). During that time, the device may pull the SDA line Low for acknowledge or outputting read data. If the master controls the SDA line High, it will conflict with the device output Low then it makes a current overload. It may cause instantaneous power down and may damage the device.

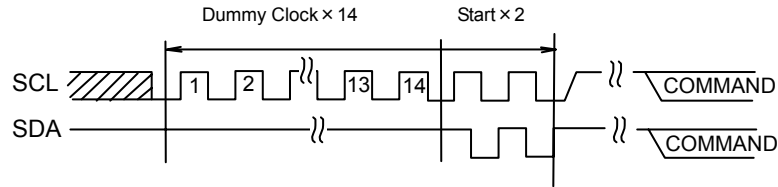

Figure 13-(a) Dummy Clock × 14 + Start + Start

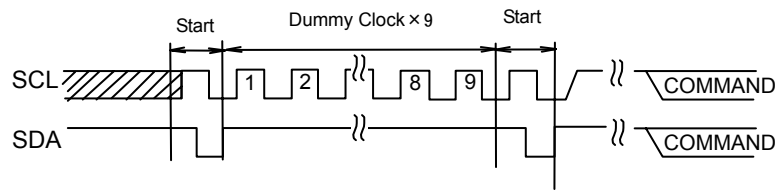

Figure 13-(b) Start + Dummy Clock × 9 + Start

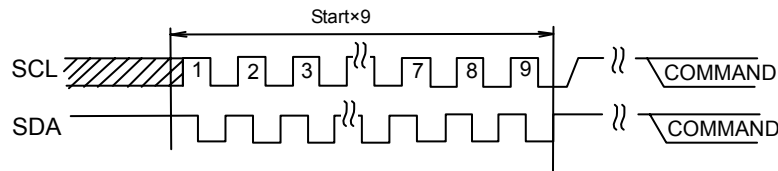

Figure 13-(c) Start × 9

●Acknowledge Polling

Since the device ignores all input commands during the internal write cycle, no ACK will be returned. When the master sends the next command following the write command, and the device returns the ACK, it means that the program is completed. If no ACK is returned, it means that the device is still busy. By using Acknowledge polling, the waiting time is minimized to less than  $t_{WR}=5ms$ . To prevent operating Write or Current Read immediately after Write, first send the slave address ( $R/\bar{W}$  is "High" or "Low"). After the device returns the ACK, continue word address input or data output, respectively.

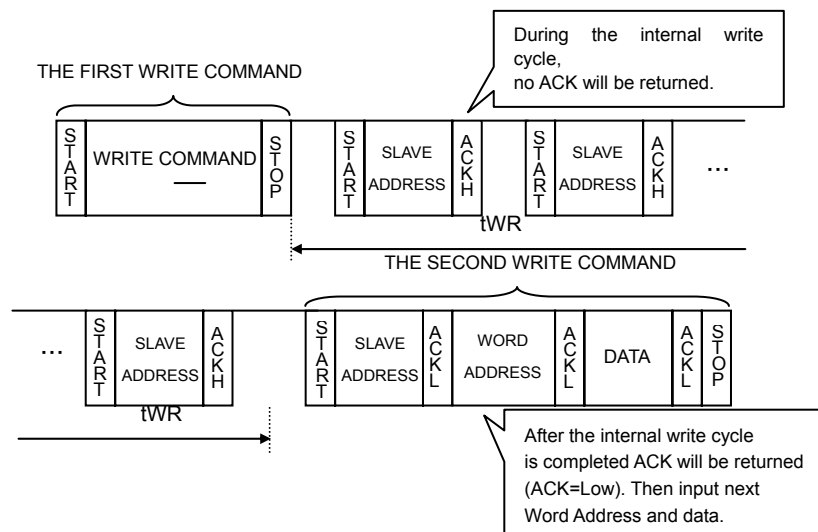

Figure 14. Successive Write Operation By Acknowledge Polling



### ○Minimum RPU

The minimum value of RPU is determined by following factors:

- ① Meets the condition that  $VOLMAX=0.4V$ ,  $IOLMAX=3mA$  when the output is Low.

$$\frac{VCC-VOL}{RPU} \leq IOL$$

$$\therefore RPU \geq \frac{VCC-VOL}{IOL}$$

- ②  $VOLMAX=0.4V$  must be lower than the input Low level of the microcontroller and the EEPROM including the recommended noise margin of  $0.1V_{CC}$ .

$$VOLMAX \leq VIL - 0.1 V_{CC}$$

Examples:  $V_{CC}=3V$ ,  $VOL=0.4V$ ,  $IOL=3mA$ , the VIL of the controller and

According to ①

$$RPU \geq \frac{3-0.4}{3 \times 10^{-3}}$$

$$\geq 867 [\Omega]$$

the EEPROM is  $VIL=0.3V_{CC}$ ,

$$\begin{aligned} \text{and} \quad VOL &= 0.4 [V] \\ VIL &= 0.3 \times 3 \\ &= 0.9 [V] \end{aligned}$$

so that condition ② is met

### ○SCL Pin Pull-up Resistor

When SCL is controlled by the CMOS output the pull-up resistor at SCL is not required.

However, should SCL be set to Hi-Z, connection of a pull-up resistor between SCL and  $V_{CC}$  is recommended.

Several  $k\Omega$  are recommended for the pull-up resistor in order to drive the output port of the microcontroller.

### ●Notes For Power Supply

$V_{CC}$  rises through the low voltage region in which the internal circuit of the IC and the controller are unstable. Therefore, the device may not work properly due to an incomplete reset of the internal circuit. To prevent this, the device has a P.O.R. and  $LV_{CC}$  feature. At power up, maintain the following conditions to ensure functions of P.O.R. and  $LV_{CC}$ .

- "SDA='H'" and "SCL='L' or 'H'".
- Follow the recommended conditions of  $t_R$ ,  $t_{OFF}$ ,  $V_{bot}$  for the P.O.R. function during power up.

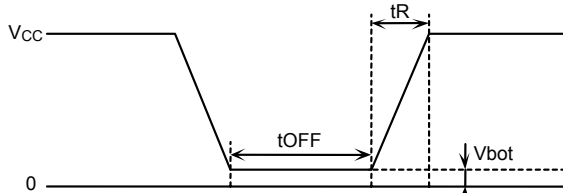

Figure 17.  $V_{CC}$  rising wave from 0

Recommended conditions of $t_R$ , $t_{OFF}$ , $V_{bot}$		
$t_R$	$t_{OFF}$	$V_{bot}$
Below 10ms	Above 10ms	Below 0.3V
Below 100ms	Above 10ms	Below 0.2V

- Prevent SDA and SCL from being "Hi-Z".

In case conditions 1 and/or 2 cannot be met, take following actions:

A) If unable to keep condition 1 ( SDA is "Low" during power up):

→ Control SDA, SCL to be "High" as shown in figure below.

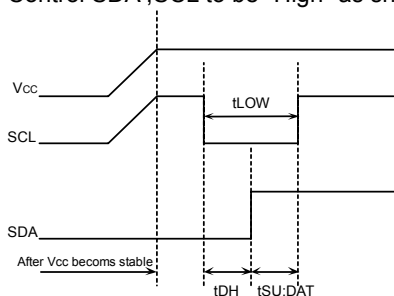

Figure 18. SCL="H" and SDA="L"

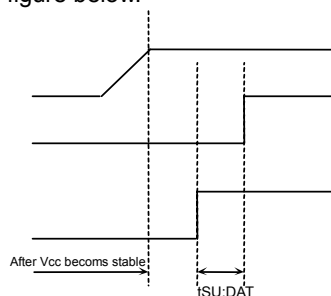

Figure 19. SCL="L" and SDA="L"

B) If unable to keep condition 2.

→ After power becomes stable, execute software reset. (See Figure 13.)

C) If unable to keep both conditions 1 and 2.

→ Follow the instruction A first, then the instruction B.

**●LVcc Circuit**

LVcc circuit inhibits write operation at low voltage, and prevents an inadvertent write. Write operation is inhibited below the LVcc voltage (Typ.=1.2V).

**●Vcc NOISE****○Bypass Condenser**

Noise and surges on power line may cause abnormal function. It is recommended that the bypass condensers (0.1 $\mu$ F) are attached on the Vcc and GND line beside the device. It is also recommended to attach bypass condensers on the board close to the connector.

**●Notes for Use**

- 1) Described numeric values and data are design representative values, and the values are not guaranteed.
- 2) We believe that application circuit examples are recommendable, however, in actual use, confirm characteristics further sufficiently. In the case of use by changing the fixed number of external parts, make your decision with sufficient margin in consideration of static characteristics and transition characteristics and fluctuations of external parts and our LSI.
- 3) Absolute maximum ratings  
If the absolute maximum ratings such as impressed voltage and operating temperature range and so forth are exceeded, LSI may be destructed. Do not impress voltage and temperature exceeding the absolute maximum ratings. In the case of fear exceeding the absolute maximum ratings, take physical safety countermeasures such as fuses, and see to it that conditions exceeding the absolute maximum ratings should not be impressed to LSI.
- 4) GND electric potential  
Set the voltage of GND terminal lowest at any action condition. Make sure that each terminal voltages is lower than that of GND terminal.
- 5) Heat design  
In consideration of permissible dissipation in actual use condition, carry out heat design with sufficient margin.
- 6) Terminal to terminal shortcircuit and wrong packaging  
When to package LSI onto a board, pay sufficient attention to LSI direction and displacement. Wrong packaging may destruct LSI. And in the case of shortcircuit between LSI terminals and terminals and power source, terminal and GND owing to foreign matter, LSI may be destructed.
- 7) Use in a strong electromagnetic field may cause malfunction, therefore, evaluated design sufficiently

**Status of this document**

The Japanese version of this document is formal specification. A customer may use this translation version only for a reference to help reading the formal version.

If there are any differences in translation version of this document formal version takes priority.

### ● Ordering Information

#### Product Code Description

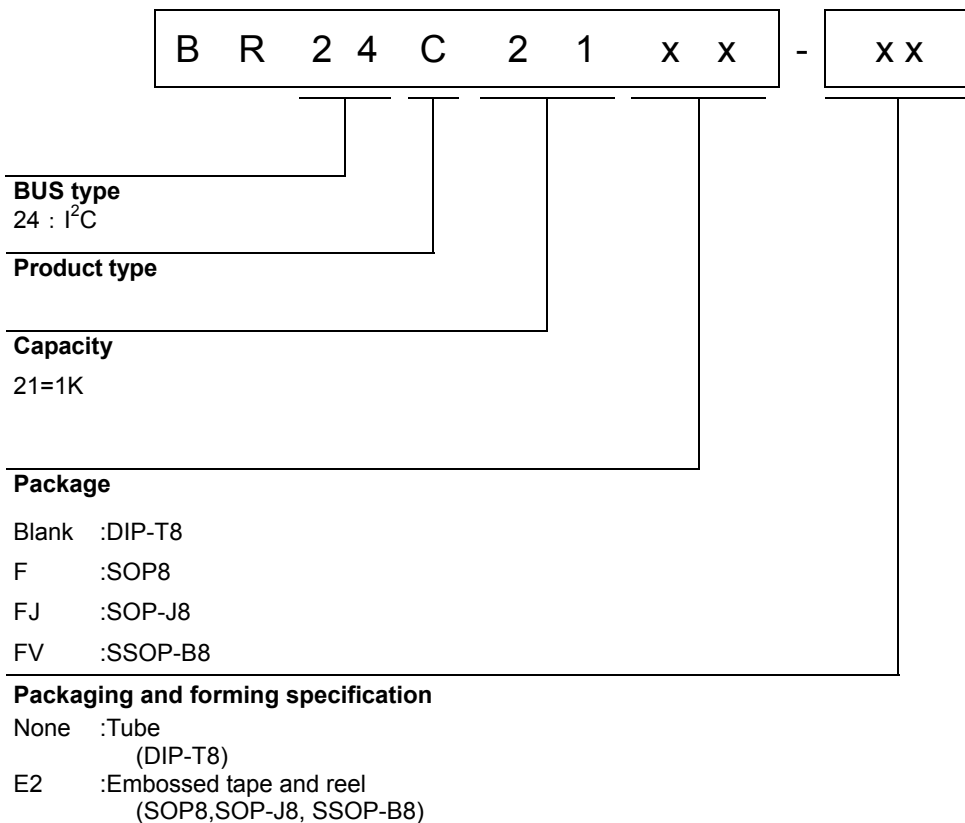

### ● Lineup

Capacity	Package	
	Type	Quantity
1K	DIP-T8	Tube of 2000
	SOP8	Reel of 2500
	SOP-J8	
	SSOP-B8	

●Physical Dimension Tape and Reel Information

DIP-T8

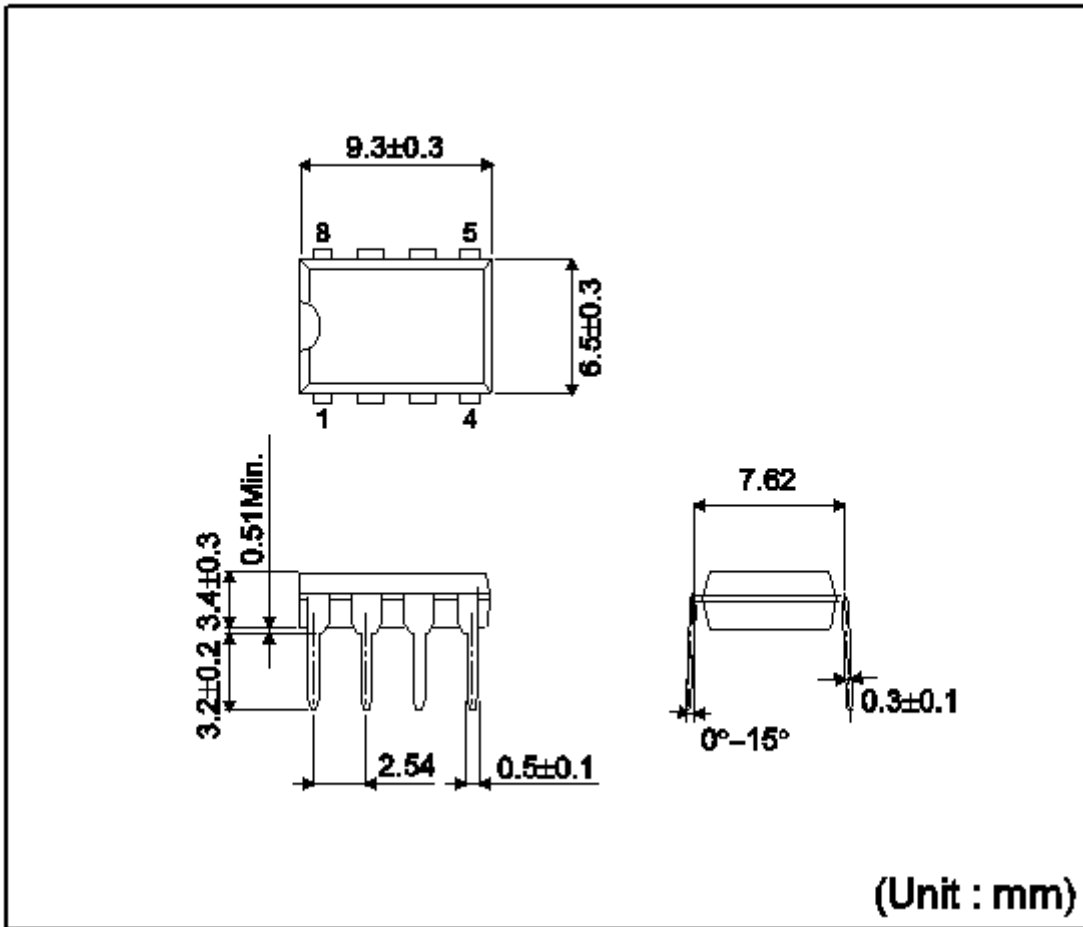

<Tape and Reel information>

Container	Tube
Quantity	2000pcs
Direction of feed	Direction of products is fixed in a container tube

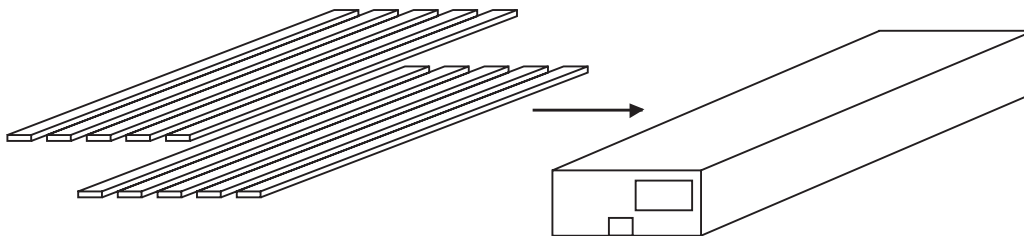

\* Order quantity needs to be multiple of the minimum quantity.

●Physical Dimension Tape and Reel Information - Continued

SOP8

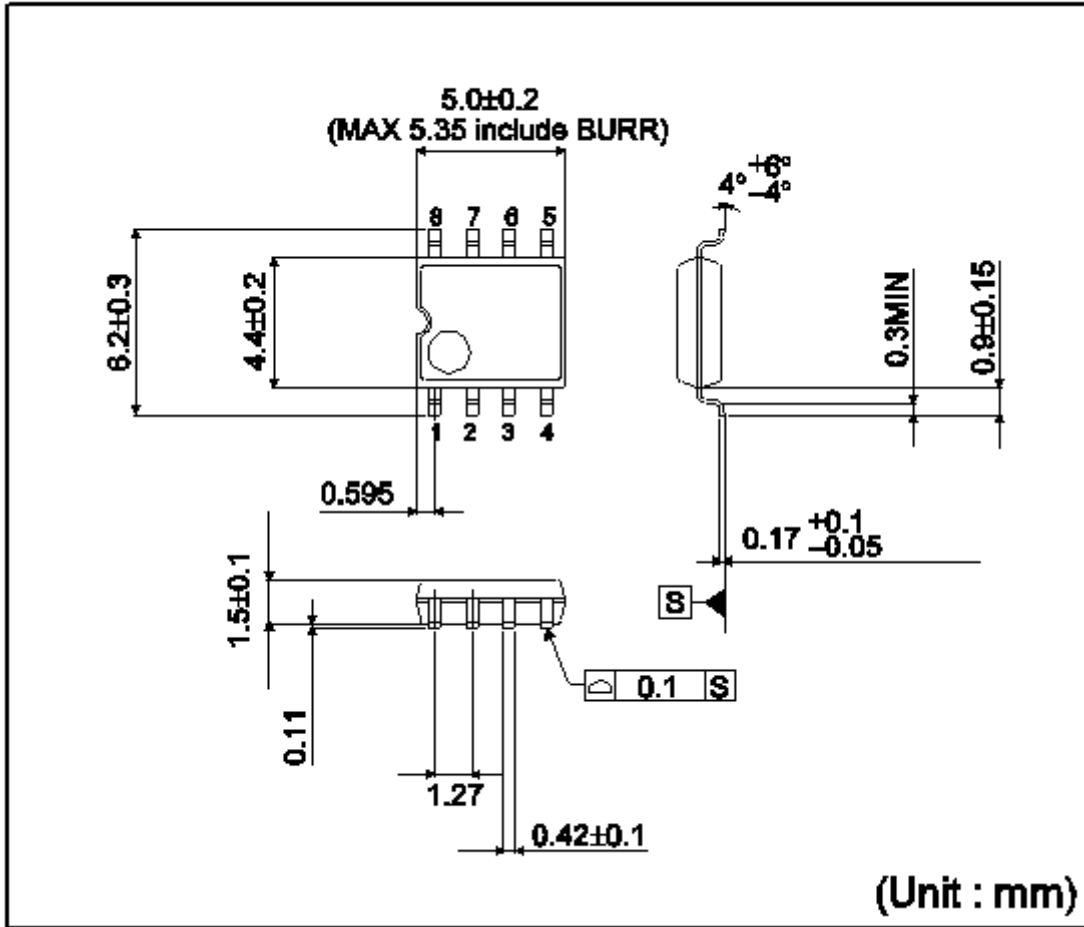

<Tape and Reel information>

Tape	Embossed carrier tape
Quantity	2500pcs
Direction of feed	E2 ( The direction is the 1pin of product is at the upper left when you hold reel on the left hand and you pull out the tape on the right hand )

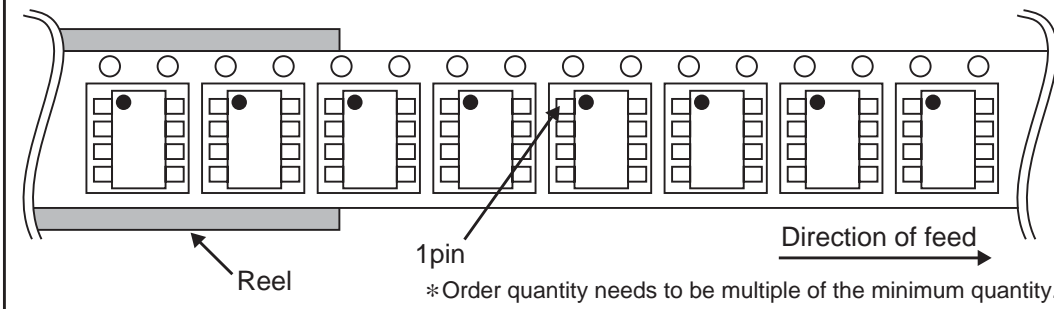

●Physical Dimension Tape and Reel Information - Continued

SOP-J8

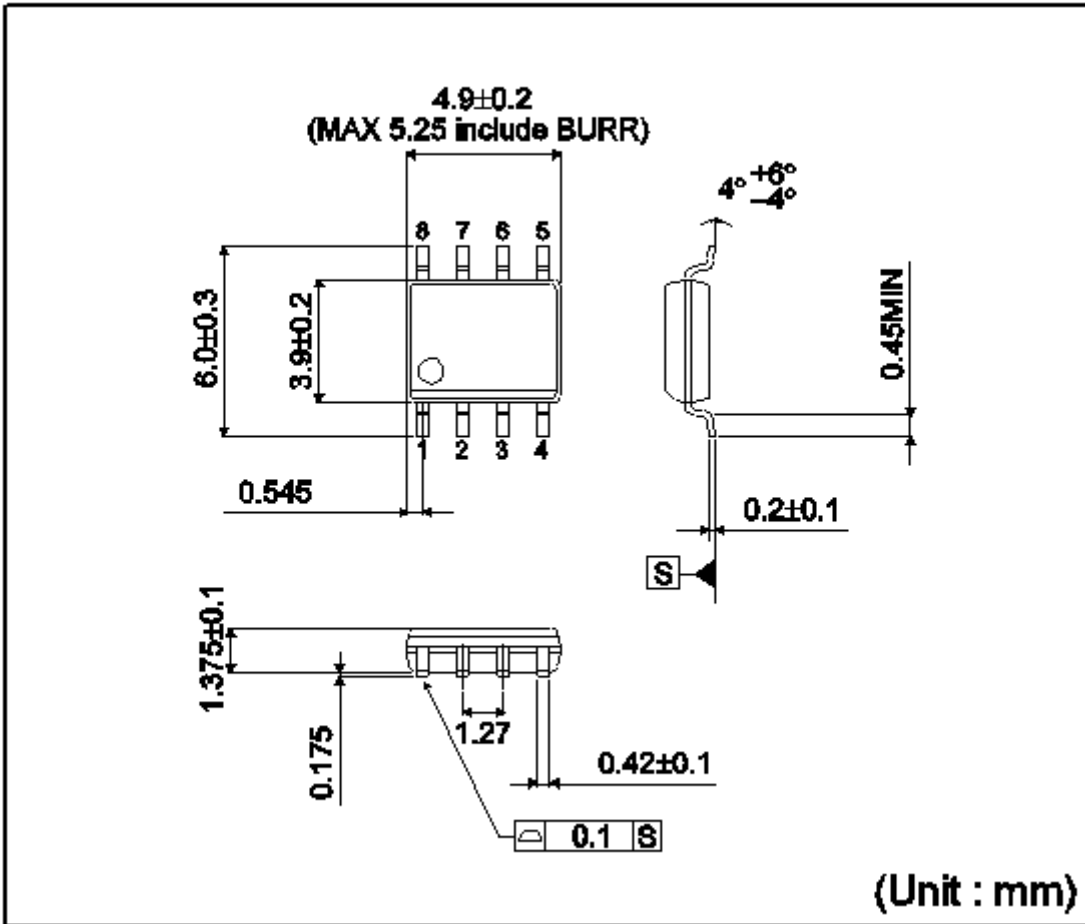

<Tape and Reel information>

Tape	Embossed carrier tape
Quantity	2500pcs
Direction of feed	E2 ( The direction is the 1pin of product is at the upper left when you hold reel on the left hand and you pull out the tape on the right hand )

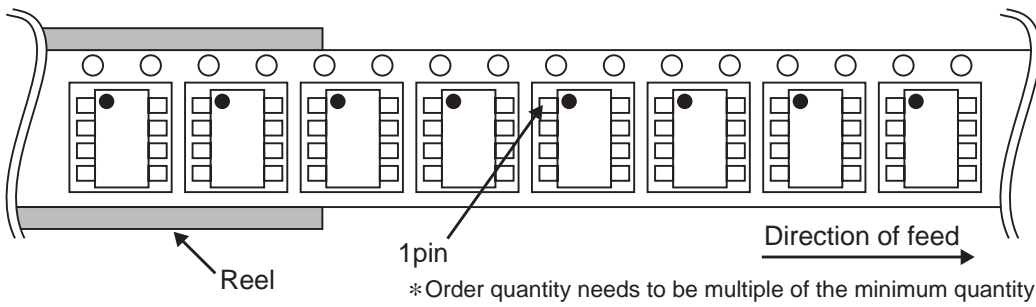

●Physical Dimension Tape and Reel Information - Continued

SSOP-B8

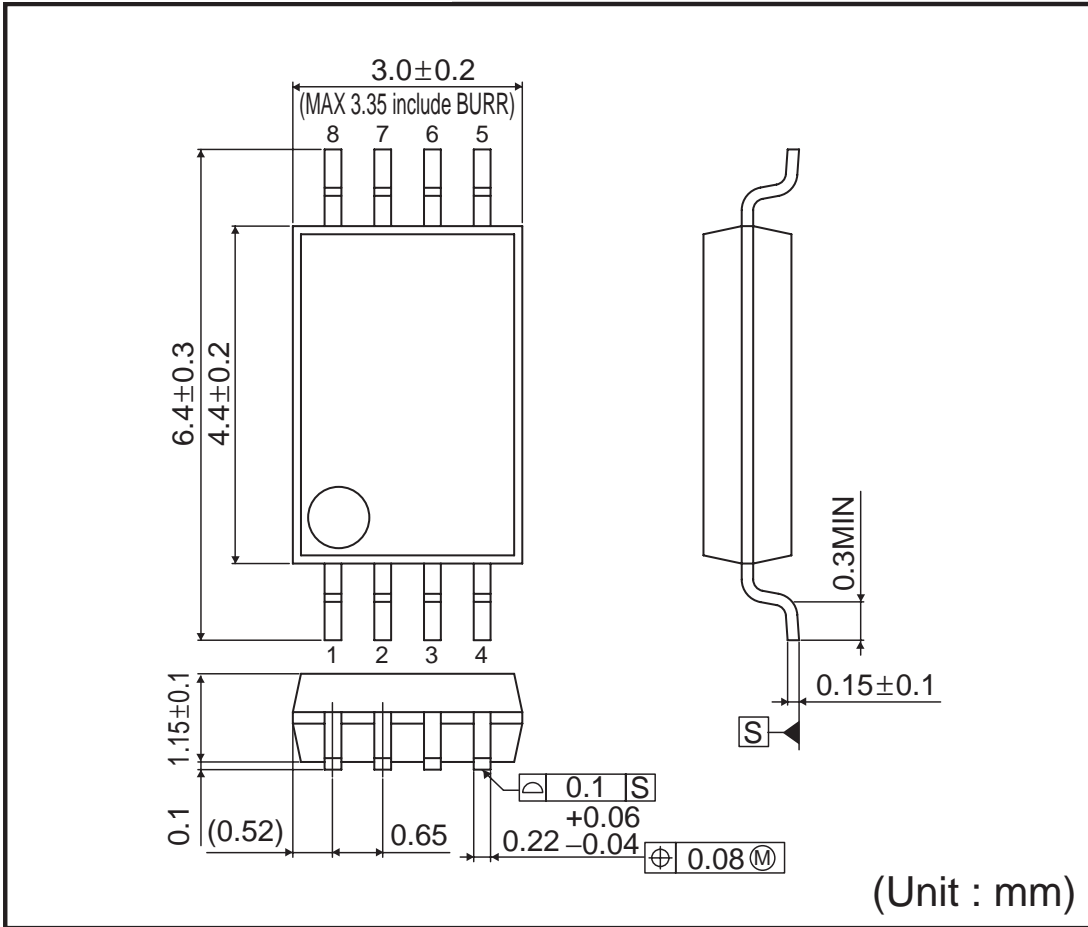

<Tape and Reel information>

Tape	Embossed carrier tape
Quantity	2500pcs
Direction of feed	E2 ( The direction is the 1pin of product is at the upper left when you hold reel on the left hand and you pull out the tape on the right hand )

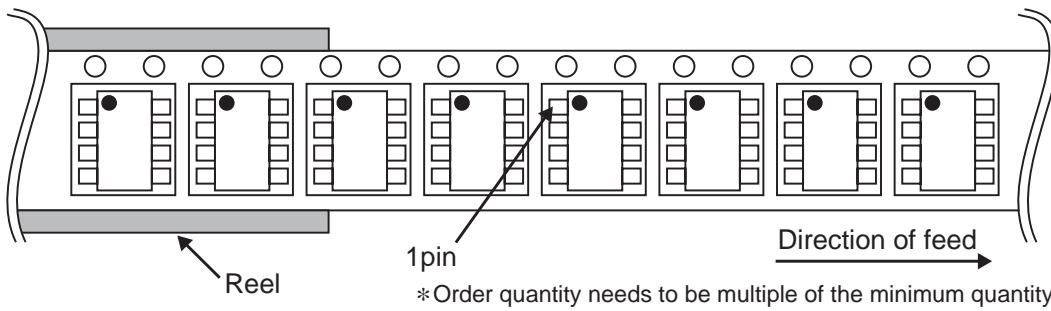

●Marking Diagrams

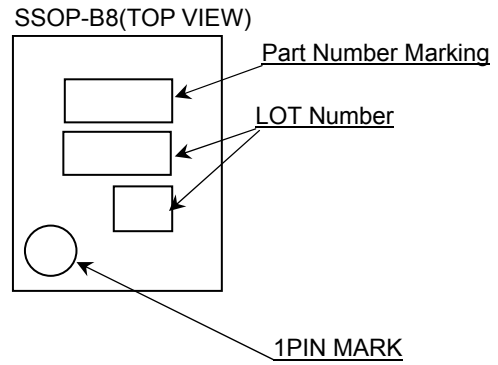
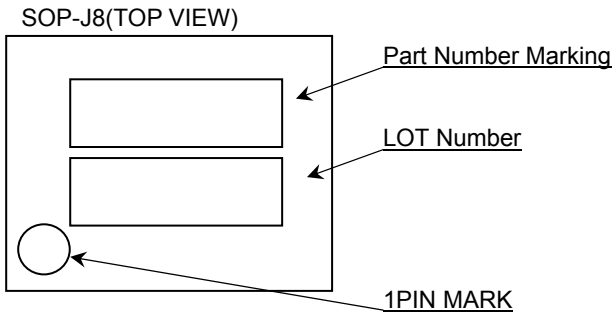
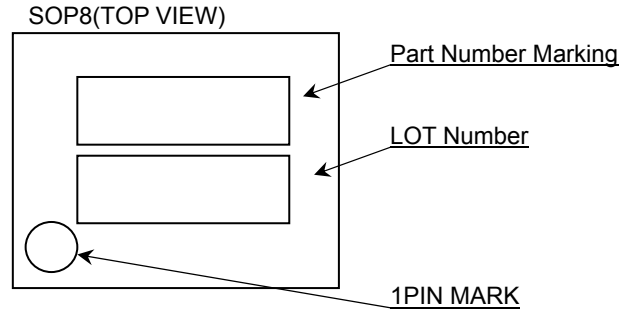
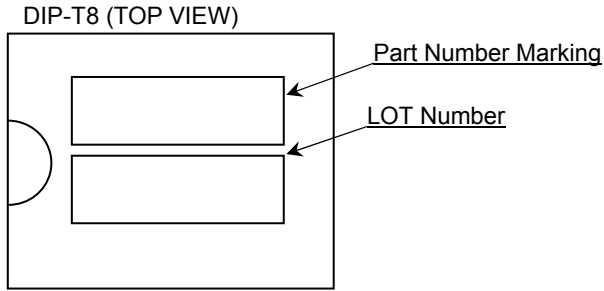

●Marking Information

Capacity	Product Name Marking	Package Type
1K	BR24C21	DIP-T8
	C21	SOP8
		SOP-J8
		SSOP-B8

## ●Revision History

Date	Revision	Changes
10.Jul.2012	001	New Release
30.Oct.2012	0002	P10 The expression of ② is corrected Figure 17, Figure 18 and Figure 19 is corrected

# Notice

## Precaution on using ROHM Products

- Our Products are designed and manufactured for application in ordinary electronic equipments (such as AV equipment, OA equipment, telecommunication equipment, home electronic appliances, amusement equipment, etc.). If you intend to use our Products in devices requiring extremely high reliability (such as medical equipment <sup>(Note 1)</sup>, transport equipment, traffic equipment, aircraft/spacecraft, nuclear power controllers, fuel controllers, car equipment including car accessories, safety devices, etc.) and whose malfunction or failure may cause loss of human life, bodily injury or serious damage to property ("Specific Applications"), please consult with the ROHM sales representative in advance. Unless otherwise agreed in writing by ROHM in advance, ROHM shall not be in any way responsible or liable for any damages, expenses or losses incurred by you or third parties arising from the use of any ROHM's Products for Specific Applications.

(Note1) Medical Equipment Classification of the Specific Applications

JAPAN	USA	EU	CHINA
CLASS III	CLASS III	CLASS II b	CLASS III
CLASS IV		CLASS III	

- ROHM designs and manufactures its Products subject to strict quality control system. However, semiconductor products can fail or malfunction at a certain rate. Please be sure to implement, at your own responsibilities, adequate safety measures including but not limited to fail-safe design against the physical injury, damage to any property, which a failure or malfunction of our Products may cause. The following are examples of safety measures:
  - Installation of protection circuits or other protective devices to improve system safety
  - Installation of redundant circuits to reduce the impact of single or multiple circuit failure
- Our Products are designed and manufactured for use under standard conditions and not under any special or extraordinary environments or conditions, as exemplified below. Accordingly, ROHM shall not be in any way responsible or liable for any damages, expenses or losses arising from the use of any ROHM's Products under any special or extraordinary environments or conditions. If you intend to use our Products under any special or extraordinary environments or conditions (as exemplified below), your independent verification and confirmation of product performance, reliability, etc. prior to use, must be necessary:
  - Use of our Products in any types of liquid, including water, oils, chemicals, and organic solvents
  - Use of our Products outdoors or in places where the Products are exposed to direct sunlight or dust
  - Use of our Products in places where the Products are exposed to sea wind or corrosive gases, including Cl<sub>2</sub>, H<sub>2</sub>S, NH<sub>3</sub>, SO<sub>2</sub>, and NO<sub>2</sub>
  - Use of our Products in places where the Products are exposed to static electricity or electromagnetic waves
  - Use of our Products in proximity to heat-producing components, plastic cords, or other flammable items
  - Sealing or coating our Products with resin or other coating materials
  - Use of our Products without cleaning residue of flux (even if you use no-clean type fluxes, cleaning residue of flux is recommended); or Washing our Products by using water or water-soluble cleaning agents for cleaning residue after soldering
  - Use of the Products in places subject to dew condensation
- The Products are not subject to radiation-proof design.
- Please verify and confirm characteristics of the final or mounted products in using the Products.
- In particular, if a transient load (a large amount of load applied in a short period of time, such as pulse. is applied, confirmation of performance characteristics after on-board mounting is strongly recommended. Avoid applying power exceeding normal rated power; exceeding the power rating under steady-state loading condition may negatively affect product performance and reliability.
- De-rate Power Dissipation depending on ambient temperature. When used in sealed area, confirm that it is the use in the range that does not exceed the maximum junction temperature.
- Confirm that operation temperature is within the specified range described in the product specification.
- ROHM shall not be in any way responsible or liable for failure induced under deviant condition from what is defined in this document.

## Precaution for Mounting / Circuit board design

- When a highly active halogenous (chlorine, bromine, etc.) flux is used, the residue of flux may negatively affect product performance and reliability.
- In principle, the reflow soldering method must be used on a surface-mount products, the flow soldering method must be used on a through hole mount products. If the flow soldering method is preferred on a surface-mount products, please consult with the ROHM representative in advance.

For details, please refer to ROHM Mounting specification

### Precautions Regarding Application Examples and External Circuits

1. If change is made to the constant of an external circuit, please allow a sufficient margin considering variations of the characteristics of the Products and external components, including transient characteristics, as well as static characteristics.
2. You agree that application notes, reference designs, and associated data and information contained in this document are presented only as guidance for Products use. Therefore, in case you use such information, you are solely responsible for it and you must exercise your own independent verification and judgment in the use of such information contained in this document. ROHM shall not be in any way responsible or liable for any damages, expenses or losses incurred by you or third parties arising from the use of such information.

### Precaution for Electrostatic

This Product is electrostatic sensitive product, which may be damaged due to electrostatic discharge. Please take proper caution in your manufacturing process and storage so that voltage exceeding the Products maximum rating will not be applied to Products. Please take special care under dry condition (e.g. Grounding of human body / equipment / solder iron, isolation from charged objects, setting of Ionizer, friction prevention and temperature / humidity control).

### Precaution for Storage / Transportation

1. Product performance and soldered connections may deteriorate if the Products are stored in the places where:
  - [a] the Products are exposed to sea winds or corrosive gases, including Cl<sub>2</sub>, H<sub>2</sub>S, NH<sub>3</sub>, SO<sub>2</sub>, and NO<sub>2</sub>
  - [b] the temperature or humidity exceeds those recommended by ROHM
  - [c] the Products are exposed to direct sunshine or condensation
  - [d] the Products are exposed to high Electrostatic
2. Even under ROHM recommended storage condition, solderability of products out of recommended storage time period may be degraded. It is strongly recommended to confirm solderability before using Products of which storage time is exceeding the recommended storage time period.
3. Store / transport cartons in the correct direction, which is indicated on a carton with a symbol. Otherwise bent leads may occur due to excessive stress applied when dropping of a carton.
4. Use Products within the specified time after opening a humidity barrier bag. Baking is required before using Products of which storage time is exceeding the recommended storage time period.

### Precaution for Product Label

A two-dimensional barcode printed on ROHM Products label is for ROHM's internal use only.

### Precaution for Disposition

When disposing Products please dispose them properly using an authorized industry waste company.

### Precaution for Foreign Exchange and Foreign Trade act

Since concerned goods might be fallen under listed items of export control prescribed by Foreign exchange and Foreign trade act, please consult with ROHM in case of export.

### Precaution Regarding Intellectual Property Rights

1. All information and data including but not limited to application example contained in this document is for reference only. ROHM does not warrant that foregoing information or data will not infringe any intellectual property rights or any other rights of any third party regarding such information or data.
2. ROHM shall not have any obligations where the claims, actions or demands arising from the combination of the Products with other articles such as components, circuits, systems or external equipment (including software).
3. No license, expressly or implied, is granted hereby under any intellectual property rights or other rights of ROHM or any third parties with respect to the Products or the information contained in this document. Provided, however, that ROHM will not assert its intellectual property rights or other rights against you or your customers to the extent necessary to manufacture or sell products containing the Products, subject to the terms and conditions herein.

### Other Precaution



1. This document may not be reprinted or reproduced, in whole or in part, without prior written consent of ROHM.
2. The Products may not be disassembled, converted, modified, reproduced or otherwise changed without prior written consent of ROHM.
3. In no event shall you use in any way whatsoever the Products and the related technical information contained in the Products or this document for any military purposes, including but not limited to, the development of mass-destruction weapons.
4. The proper names of companies or products described in this document are trademarks or registered trademarks of ROHM, its affiliated companies or third parties.

**General Precaution**

1. Before you use our Products, you are requested to carefully read this document and fully understand its contents. ROHM shall not be in any way responsible or liable for failure, malfunction or accident arising from the use of any ROHM's Products against warning, caution or note contained in this document.
2. All information contained in this document is current as of the issuing date and subject to change without any prior notice. Before purchasing or using ROHM's Products, please confirm the latest information with a ROHM sales representative.
3. The information contained in this document is provided on an "as is" basis and ROHM does not warrant that all information contained in this document is accurate and/or error-free. ROHM shall not be in any way responsible or liable for any damages, expenses or losses incurred by you or third parties resulting from inaccuracy or errors of or concerning such information.

## Looking for pricing, stock, or lifecycle information?

Click below to explore more details on WIN SOURCE:

-  [View BR24C21F-E2 on WIN SOURCE](#)
-  [Rohm Semiconductor](#) Information

## Optimize Your Supply Chain with WIN SOURCE Solutions

-  Global Sourcing Solution
-  Obsolete Management
-  Cost Control Management
-  Shortage Management
-  Alternative Solution
-  Excess Inventory Management