



**THE DATASHEET OF  
6P30006ANLGI**



## Description

The IDT6P30006A is a low-power, eight output clock distribution circuit. The device takes a TCXO or LVCMOS input and generates eight high-quality outputs.

It includes a redundant input with automatic glitch-free switching when the primary reference is removed. The primary input may be selected by the user by pulling the SEL pin low or high. If the primary input is removed and brought back, it will not be re-selected until 1024 cycles have passed.

The IDT6P30006A specifically addresses the needs of handheld applications in both performance and package size. The device is packaged in a small 4mm x 4mm 24-pin QFN, allowing optimal use for limited board space.

## Features

- Packaged in 24-pin QFN
- LVCMOS or TCXO sine wave input
- +1.8 V operating voltage
- Glitch-free input switching
- Eight buffered square wave outputs at 1.8 V LVCMOS levels
- Individual output enables controlled via I<sup>2</sup>C or OEx
- Pb free, RoHS compliant package
- Industrial temperature range (-40°C to +85°C)

## Block Diagram

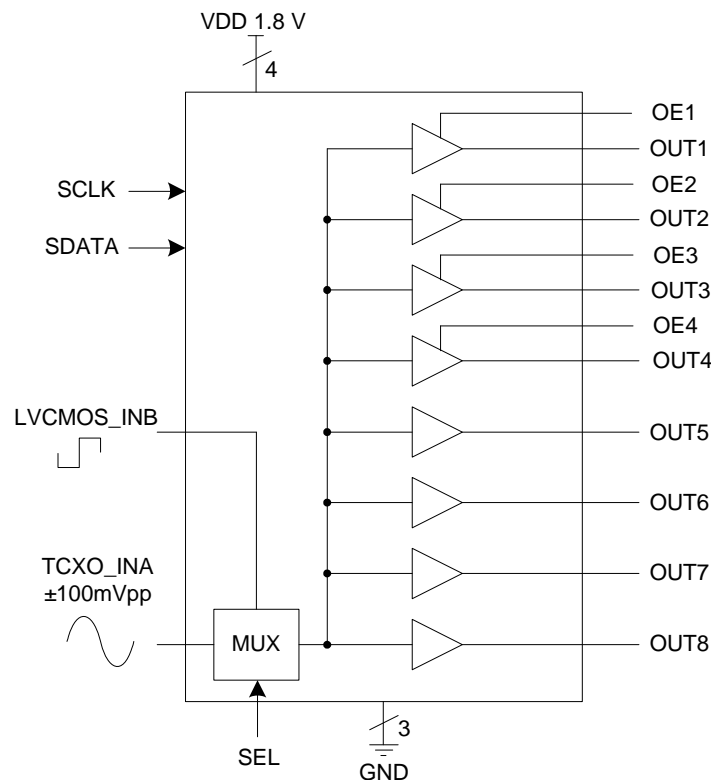

## Pin Assignment

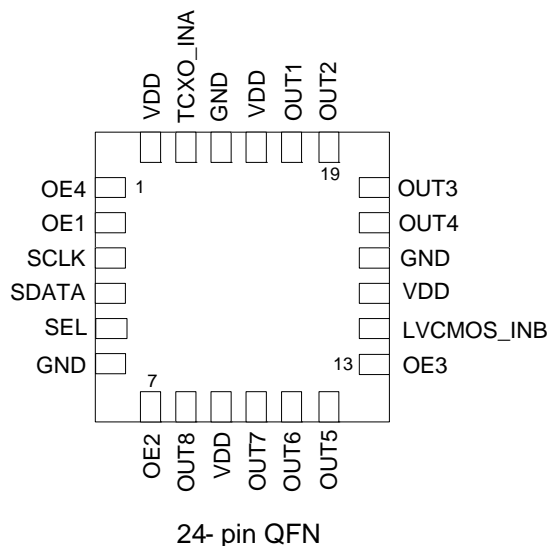

## SEL Pin Configuration Table

SEL	Primary Input
0	LVC MOS_INB
1	TCXO_INA

## OE Pin Configuration Table

OEx	OUTx
0	Disabled
1	Enabled

## Pin Descriptions

Pin Number	Pin Name	Pin Type	Pin Description
1	OE4	Input	Output enable control for OUT4. Internal pull-up resistor. See table above.
2	OE1	Input	Output enable control for OUT1. Internal pull-up resistor. See table above.
3	SCLK	Input	I <sup>2</sup> C clock input.
4	SDATA	I/O	I <sup>2</sup> C data input.
5	SEL	Input	Select pin for primary inputs. See table above. Internal pull-up resistor.
6	GND	Power	Connect to ground.
7	OE2	Input	Output enable control for OUT2. Internal pull-up resistor. See table above.
8	OUT8	Output	Buffered output. Outputs tri-state with weak pull-down when disabled.
9	VDD	Power	Connect to +1.8 V.
10	OUT7	Output	Buffered output. Outputs tri-state with weak pull-down when disabled.
11	OUT6	Output	Buffered output. Outputs tri-state with weak pull-down when disabled.
12	OUT5	Output	Buffered output. Outputs tri-state with weak pull-down when disabled.
13	OE3	Input	Output enable control for OUT3. Internal pull-up resistor. See table above.
14	LVC MOS_INB	Input	Connect to 13 MHz LVC MOS clock input. See table above.
15	VDD	Power	Connect to +1.8 V.
16	GND	Power	Connect to ground.

Pin Number	Pin Name	Pin Type	Pin Description
17	OUT4	Output	Buffered output. Outputs tri-state with weak pull-down when disabled.
18	OUT3	Output	Buffered output. Outputs tri-state with weak pull-down when disabled.
19	OUT2	Output	Buffered output. Outputs tri-state with weak pull-down when disabled.
20	OUT1	Output	Buffered output. Outputs tri-state with weak pull-down when disabled.
21	VDD	Power	Connect to +1.8 V.
22	GND	Power	Connect to ground.
23	TCXO_INA	Input	Connect to 13 MHz TCXO input.
24	VDD	Power	Connect to +1.8 V.

## General I<sup>2</sup>C Serial Interface

### How to Write:

- Controller (host) sends a start bit
- Controller (host) sends the write address D2<sub>(H)</sub>
- IDT clock will *acknowledge*
- Controller (host) sends the beginning byte location =N
- IDT clock will *acknowledge*
- Controller (host) sends the data byte count = X
- IDT clock will *acknowledge*
- Controller (host) starts sending *Byte N through Byte N + X - 1* (see Note 2)
- IDT clock will *acknowledge* each byte *one at a time*
- Controller (host) sends a Stop bit

Index Block Write Operation								
Controller (Host)		IDT (Slave/Receiver)						
T	starTbit							
Slave Address D2 <sub>(H)</sub>								
WR	WRite							
Beginning Byte = N		ACK						
Beginning Byte = N		ACK						
Data Byte Count = X		ACK						
Beginning Byte = N		<table border="1"> <tr><td>.</td></tr> <tr><td>X</td></tr> <tr><td>B</td></tr> <tr><td>Y</td></tr> <tr><td>T</td></tr> <tr><td>E</td></tr> </table>	.	X	B	Y	T	E
.								
X								
B								
Y								
T								
E								
O		ACK						
O		O						
O		O						
O		O						
Byte N + X - 1		ACK						
P	stoP bit							

### How to Read:

- Controller (host) sends a start bit
- Controller (host) sends the write address D2<sub>(H)</sub>
- IDT clock will *acknowledge*
- Controller (host) sends the beginning byte location =N
- IDT clock will *acknowledge*
- Controller (host) will send a separate start bit
- Controller (host) sends the read address D3<sub>(H)</sub>
- IDT clock will *acknowledge*
- Controller (host) sends the data byte count = X
- IDT clock sends *Byte N + X - 1*
- IDT clock sends *Byte 0 through byte X (if X<sub>(H)</sub> was written to byte 8)*
- Controller (host) will need to acknowledge each byte
- Controller (host) will send a not acknowledge bit
- Controller (host) will send a stop bit

Index Block Read Operation								
Controller (Host)		IDT (Slave/Receiver)						
T	starTbit							
Slave Address D2 <sub>(H)</sub>								
WR	WRite							
Beginning Byte = N		ACK						
Beginning Byte = N		ACK						
RT	Repeat starT							
Slave Address D3 <sub>(H)</sub>								
RD	ReaD							
Beginning Byte = N		ACK						
Beginning Byte = N		ACK						
Data Byte Count = X		Data Byte Count = X						
ACK								
Beginning Byte N		<table border="1"> <tr><td>.</td></tr> <tr><td>X</td></tr> <tr><td>B</td></tr> <tr><td>Y</td></tr> <tr><td>T</td></tr> <tr><td>E</td></tr> </table>	.	X	B	Y	T	E
.								
X								
B								
Y								
T								
E								
ACK		O						
O		O						
O		O						
O		O						
Byte N + X - 1		Byte N + X - 1						
N	Not acknowledge							
P	stoP bit							

## I<sup>2</sup>C Address

The IDT6P30006A is a slave-only device that supports block read and block write protocol using a single 7 bit address and read/write bit. A block write (D2<sub>(H)</sub>) or block read (D3<sub>(H)</sub>) is made up of seven (7) bits and one (1) read/write bit.

A6	A5	A4	A3	A2	A1	A0	R/W#
1	1	0	1	0	0	1	X

In applications where the indexed block write and block read are used, the dummy byte (bit 11-18) functions as a register-offset (8 bits) pointer.

## Byte 0: Control Register

Bit	Description	Type	Power Up Condition	Output(s) Affected	Notes
7	Reserved	RW	Undefined	Not applicable	
6	Reserved	RW	Undefined	Not applicable	
5	Reserved	RW	Undefined	Not applicable	
4	Reserved	RW	Undefined	Not applicable	
3	OE for clock output	RW	1	Output_5 clock output	1=enabled 0=disabled
2	OE for clock output	RW	1	Output_6 clock output	1=enabled 0=disabled
1	OE for clock output	RW	1	Output_7 clock output	1=enabled 0=disabled
0	OE for clock output	RW	1	Output_8 clock output	1=enabled 0=disabled

**Byte 1: Control Register**

Bit	Description	Type	Power Up Condition	Output(s) Affected	Notes
7 to 0	Reserved	RW	Undefined	Not applicable	

**Byte 2: Control Register**

Bit	Description	Type	Power Up Condition	Output(s) Affected	Notes
7 to 0	Reserved	RW	Undefined	Not applicable	

**Byte 3: Control Register**

Bit	Description	Type	Power Up Condition	Output(s) Affected	Notes
7 to 0	Reserved	RW	Undefined	Not applicable	

**Byte 4 through 5: Control Register**

Bit	Description	Type	Power Up Condition	Output(s) Affected	Notes
7 to 0	Reserved	RW	Undefined	Not applicable	

**Byte 6: Control Register**

Bit	Description	Type	Power Up	Output(s) Affected	Notes
7	Revision ID bit 3	RW	0	Not applicable	
6	Revision ID bit 2	RW	0	Not applicable	
5	Revision ID bit 1	RW	0	Not applicable	
4	Revision ID bit 0	RW	0	Not applicable	
3	Vendor ID bit 3	RW	0	Not applicable	
2	Vendor ID bit 2	RW	0	Not applicable	
1	Vendor ID bit 1	RW	0	Not applicable	
0	Vendor ID bit 0	RW	1	Not applicable	

## Applications Information

### External Components

A minimum number of external components are required for proper operation.

#### Decoupling Capacitors

Decoupling capacitors of 0.01  $\mu\text{F}$  should be connected between VDD and GND as close to the device as possible. Do not share ground vias between components. Route power from power source through the capacitor pad and then into IDT pin.

### PCB Layout Recommendations

For optimum device performance and lowest output phase noise, the following guidelines should be observed.

1. Each 0.01  $\mu\text{F}$  decoupling capacitor should be mounted on the component side of the board as close to the VDD pin as possible.
2. No vias should be used between decoupling capacitor and VDD pin.
3. The PCB trace to VDD pin should be kept as short as possible, as should the PCB trace to the ground via. Distance of the ferrite bead and bulk decoupling from the device is less critical.
4. An optimum layout is one with all components on the same side of the board, minimizing vias through other signal layers (any ferrite beads and bulk decoupling capacitors can be mounted on the back). Other signal traces should be routed away from the IDT6P30006A. This includes signal traces just underneath the device, or on layers adjacent to the ground plane layer used by the device.

## Absolute Maximum Ratings

Stresses above the ratings listed below can cause permanent damage to the IDT6P30006A. These ratings, which are standard values for IDT commercially rated parts, are stress ratings only. Functional operation of the device at these or any other conditions above those indicated in the operational sections of the specifications is not implied. Exposure to absolute maximum rating conditions for extended periods can affect product reliability. Electrical parameters are guaranteed only over the recommended operating temperature range.

Item	Rating
Max Supply Voltage, VDD	5 V
LVC MOS_INB, SCLK and SDATA Inputs	-0.5 V to +3.3 V
All Other Inputs and Outputs	-0.5 V to VDD+0.5 V
Ambient Operating Temperature	-40 to +85° C
Storage Temperature	-65 to +150° C
Junction Temperature	125° C
Peak Soldering Temperature	260° C

## Recommended Operation Conditions

Parameter	Min.	Typ.	Max.	Units
Ambient Operating Temperature	-40		+85	° C
Power Supply Voltage (measured in respect to GND)	1.62	+1.8	1.98	V

## DC Electrical Characteristics

Unless otherwise specified, VDD=1.8 V ±10%, Ambient Temperature -40 to +85° C

Parameter	Symbol	Conditions	Min.	Typ.	Max.	Units
Operating Supply Voltage	VDD		1.62	1.8	1.98	V
Input High Voltage	V <sub>IH</sub>	SEL, OE pins, LVC MOS_INB, TCXO_INA	0.75xVDD			V
		SCLK and SDATA	0.7xVDD			
Input Low Voltage	V <sub>IL</sub>	SEL, OE pins, LVC MOS_INB, TCXO_INA			0.35xVDD	V
		SCLK and SDATA			0.3xVDD	
High-Level Output Voltage	V <sub>OH</sub>	I <sub>OH</sub> = -4 mA	VDD-0.4			V
Low-Level Output Voltage	V <sub>OL</sub>	I <sub>OL</sub> = 4 mA			0.4	V
Operating Supply Current	IDD	No load, all outputs switching at 13 MHz		4	6	mA
		All outputs disabled		500		µA
Short Circuit Current	I <sub>OS</sub>	Single-ended clocks		±70		mA
Output Impedance	Z <sub>O</sub>	All clock outputs, OEx=1		15		Ω
Internal Pull-Up Resistor	R <sub>PU</sub>	SEL, OEx		500		kΩ
Internal Pull-Down Resistor	R <sub>PD</sub>	All clock outputs, OEx=0		250		kΩ
Input Capacitance	C <sub>IN</sub>	All input pins		6		pF

## AC Electrical Characteristics – Single-Ended Outputs

Unless otherwise stated,  $V_{DD} = 1.8\text{ V} \pm 10\%$ , Ambient Temperature  $-40$  to  $+85^\circ\text{C}$

Parameter	Symbol	Conditions	Min.	Typ.	Max.	Units
Input Frequency	$F_{IN}$		12.6	13	13.4	MHz
TCXO Input Swing			$\pm 100$		$\pm 900$	mV
Variance Input Frequencies		LVC MOS_INB, TCXO_INA, Note 2			0.4	MHz
Time Switch Clock Inputs		LVC MOS_INB, TCXO_INA, Note 3		80		$\mu\text{s}$
Output Frequency Error				0		ppm
Output Rise Time	$t_{OR}$	20% to 80%, Note 1		1	1.5	ns
Output Fall Time	$t_{OF}$	80% to 20%, Note 1		1	1.5	ns
Output Clock Duty Cycle		Measured at $V_{DD}/2$ , Note 1	45	50	55	%
Clock Stabilization Time from Power Up		Power up, output within 1% of final frequency		3	10	ms

Note 1:  $C_L = 5\text{ pF}$ .

Note 2: Delta from 13 MHz.

Note 3: By removing primary input and then bringing back primary input.

## Thermal Characteristics

Parameter	Symbol	Conditions	Min.	Typ.	Max.	Units
Thermal Resistance Junction to Ambient	$\theta_{JA}$	Still air		29.1		$^\circ\text{C/W}$
	$\theta_{JA}$	1 m/s air flow		22.8		$^\circ\text{C/W}$
	$\theta_{JA}$	2.5 m/s air flow		21.0		$^\circ\text{C/W}$
Thermal Resistance Junction to Case	$\theta_{JC}$			41.8		$^\circ\text{C/W}$

## Marking Diagram

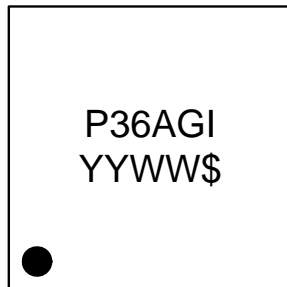

### Notes:

1. YYWW is the last two digits of the year and week that the part was assembled.
3. "\$" is the assembly mark code.
4. "G" after the two-letter package code designates RoHS compliant package.
5. "I" at the end of part number indicates industrial temperature range.
6. Bottom marking: country of origin if not USA.

### Package Outline and Package Dimensions (24-pin QFN)

Package dimensions are kept current with JEDEC Publication No. 95

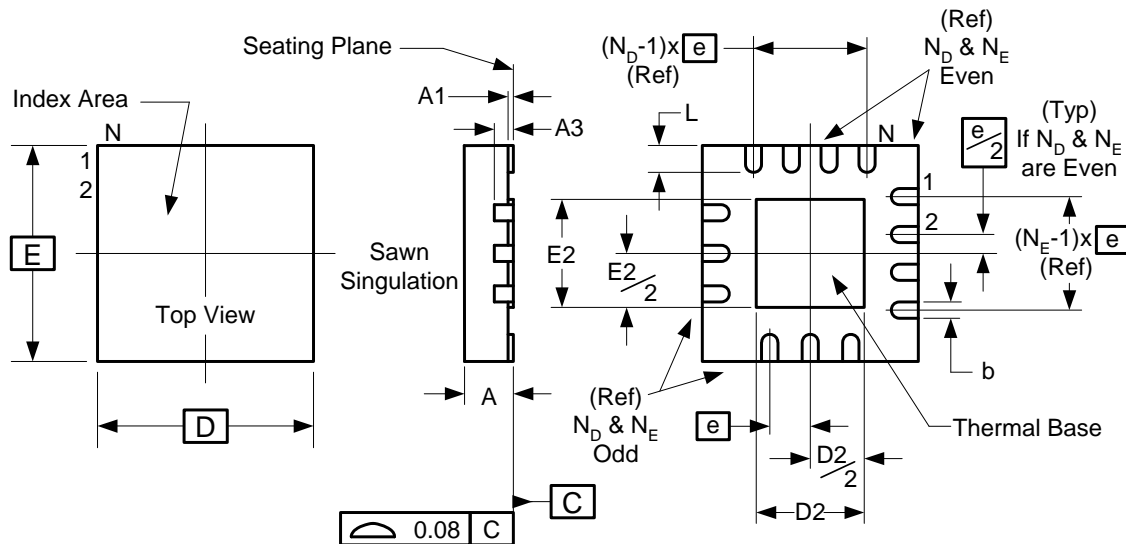

Symbol	Millimeters	
	Min	Max
A	0.80	1.00
A1	0	0.05
A3	0.25 Reference	
b	0.18	0.30
e	0.50 BASIC	
N	24	
$N_D$	6	
$N_E$	6	
D x E BASIC	4.00 x 4.00	
D2	2.3	2.55
E2	2.3	2.55
L	0.30	0.50

### Ordering Information

Part / Order Number	Marking	Shipping Packaging	Package	Temperature
6P30006ANLGI	see pg. 10	Trays	24-pin QFN	-40 to +85° C
6P30006ANLGI8		Tape and Reel	24-pin QFN	-40 to +85° C

“G” after the two-letter package code are the Pb-Free configuration and are RoHS compliant.

While the information presented herein has been checked for both accuracy and reliability, Integrated Device Technology (IDT) assumes no responsibility for either its use or for the infringement of any patents or other rights of third parties, which would result from its use. No other circuits, patents, or licenses are implied. This product is intended for use in normal commercial applications. Any other applications such as those requiring extended temperature range, high reliability, or other extraordinary environmental requirements are not recommended without additional processing by IDT. IDT reserves the right to change any circuitry or specifications without notice. IDT does not authorize or warrant any IDT product for use in life support devices or critical medical instruments.



## IMPORTANT NOTICE AND DISCLAIMER

RENESAS ELECTRONICS CORPORATION AND ITS SUBSIDIARIES (“RENESAS”) PROVIDES TECHNICAL SPECIFICATIONS AND RELIABILITY DATA (INCLUDING DATASHEETS), DESIGN RESOURCES (INCLUDING REFERENCE DESIGNS), APPLICATION OR OTHER DESIGN ADVICE, WEB TOOLS, SAFETY INFORMATION, AND OTHER RESOURCES “AS IS” AND WITH ALL FAULTS, AND DISCLAIMS ALL WARRANTIES, EXPRESS OR IMPLIED, INCLUDING, WITHOUT LIMITATION, ANY IMPLIED WARRANTIES OF MERCHANTABILITY, FITNESS FOR A PARTICULAR PURPOSE, OR NON-INFRINGEMENT OF THIRD-PARTY INTELLECTUAL PROPERTY RIGHTS.

These resources are intended for developers who are designing with Renesas products. You are solely responsible for (1) selecting the appropriate products for your application, (2) designing, validating, and testing your application, and (3) ensuring your application meets applicable standards, and any other safety, security, or other requirements. These resources are subject to change without notice. Renesas grants you permission to use these resources only to develop an application that uses Renesas products. Other reproduction or use of these resources is strictly prohibited. No license is granted to any other Renesas intellectual property or to any third-party intellectual property. Renesas disclaims responsibility for, and you will fully indemnify Renesas and its representatives against, any claims, damages, costs, losses, or liabilities arising from your use of these resources. Renesas' products are provided only subject to Renesas' Terms and Conditions of Sale or other applicable terms agreed to in writing. No use of any Renesas resources expands or otherwise alters any applicable warranties or warranty disclaimers for these products.

(Disclaimer Rev.1.01 Jan 2024)

### Corporate Headquarters

TOYOSU FORESIA, 3-2-24 Toyosu,  
Koto-ku, Tokyo 135-0061, Japan  
[www.renesas.com](http://www.renesas.com)

### Trademarks

Renesas and the Renesas logo are trademarks of Renesas Electronics Corporation. All trademarks and registered trademarks are the property of their respective owners.

### Contact Information

For further information on a product, technology, the most up-to-date version of a document, or your nearest sales office, please visit [www.renesas.com/contact-us/](http://www.renesas.com/contact-us/).

## Looking for pricing, stock, or lifecycle information?

Click below to explore more details on WIN SOURCE:

-  [View 6P30006ANLGI on WIN SOURCE](#)
-  [Renesas Electronics America](#) Information

## Optimize Your Supply Chain with WIN SOURCE Solutions

-  Global Sourcing Solution
-  Obsolete Management
-  Cost Control Management
-  Shortage Management
-  Alternative Solution
-  Excess Inventory Management