

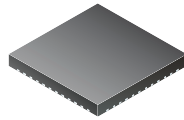

**THE DATASHEET OF  
BQ500412RGZT**





## Low System Cost, Wireless Power Controller for WPC TX A6

 Check for Samples: [bq500412](#)

### FEATURES

- Proven, Qi-Certified WPC1.1 Solution for Transmit-Side Application (suitable for 1, 2 or 3 coil configurations)
- Lowest Device Count for Full WPC1.1 12-V A6 Solution (single driver stage for all coils)
- New Standby Scheme Reduces Standby and Sleep Power Without Need for Extra Supervisor Circuit
- Improved FOD Calibration Scheme Simplifies Certification and Increases Accuracy at Higher Power (customer configurable)
- Dynamic Power Limiting™ for USB and Limited Power Source Operation When Used With 5-V Input
- Digital Demodulation Removes Need for External Filter Circuitry
- 10 Configurable LED modes Indicate Charging State and Fault Status

### APPLICATIONS

- Wireless Power Consortium (WPC1.1) Compliant Wireless Chargers For:
  - Qi-Certified Smart Phones and Other Handhelds
  - Car and Other Vehicle Accessories
- See [www.ti.com/wirelesspower](http://www.ti.com/wirelesspower) for More Information on TI's Wireless Charging Solutions

### DESCRIPTION

The bq500412 is a Qi-certified value solution that integrates all functions required to control wireless power delivery to a single WPC1.1 compliant receiver. It is WPC1.1 compliant and designed for 12-V systems, or 5-V systems with an optional boost converter, as a wireless power consortium type A6 free positioning transmitter. The bq500412 *pings* the surrounding environment for WPC compliant devices to be powered, safely engages the device, receives packet communication from the powered device and manages the power transfer according to WPC1.1 specification. To maximize flexibility in wireless power control applications, Dynamic Power Limiting™ (DPL) is featured on the bq500412 when used with an optional boost converter from a 5-V input. Dynamic Power Limiting™ enhances user experience by seamlessly optimizing the usage of power available from limited input supplies. The bq500412 supports both Foreign Object Detection (FOD) and enhanced Parasitic Metal Object Detection (PMOD) for legacy product by continuously monitoring the efficiency of the established power transfer, protecting from power lost due to metal objects misplaced in the wireless power transfer field. Should an abnormal operating condition develop during power transfer, the bq500412 handles it and provides indicator outputs. Comprehensive status and fault monitoring features enable a low cost yet robust, Qi-certified wireless power system design.

The bq500412 is available in a 48-pin, 7-mm x 7-mm QFN package.

### System Diagram and Efficiency Versus System Output Power

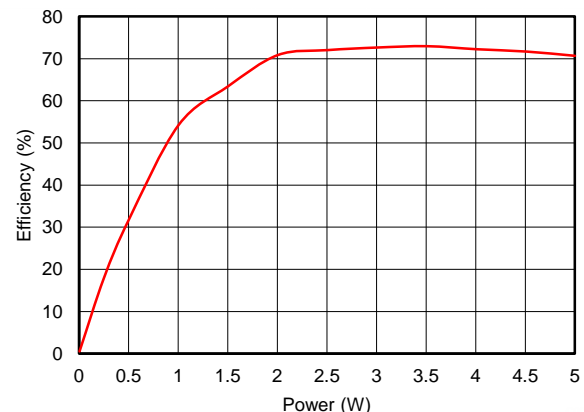
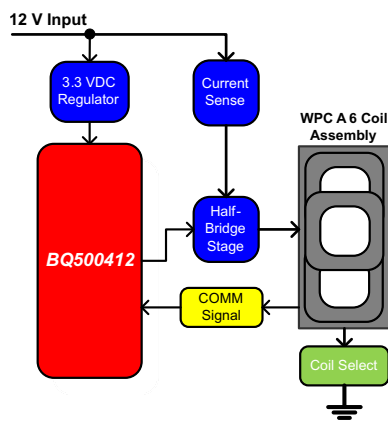

Please be aware that an important notice concerning availability, standard warranty, and use in critical applications of Texas Instruments semiconductor products and disclaimers thereto appears at the end of this data sheet.

Dynamic Power Limiting is a trademark of Texas Instruments.



These devices have limited built-in ESD protection. The leads should be shorted together or the device placed in conductive foam during storage or handling to prevent electrostatic damage to the MOS gates.

### ORDERING INFORMATION<sup>(1)</sup>

| OPERATING TEMPERATURE RANGE, T <sub>A</sub> | ORDERABLE PART NUMBER | PIN COUNT | SUPPLY       | PACKAGE | TOP SIDE MARKING |
|---|-----------------------|-----------|--------------|---------|------------------|
| -40°C to 110°C                              | BQ500412RGZR          | 48 pin    | Reel of 2500 | QFN     | BQ500412         |
|   | BQ500412RGZT          | 48 pin    | Reel of 250  | QFN     | BQ500412         |

(1) For the most current package and ordering information, see the Package Option Addendum at the end of this document, or see the TI web site at [www.ti.com](http://www.ti.com).

### ABSOLUTE MAXIMUM RATINGS<sup>(1)</sup>

over operating free-air temperature range (unless otherwise noted)

|   | VALUE |     | UNIT |
|---|-------|-----|------|
|   | MIN   | MAX |      |
| Voltage applied at V33D to GND            | -0.3  | 3.6 | V    |
| Voltage applied at V33A to GND            | -0.3  | 3.6 |      |
| Voltage applied to any pin <sup>(2)</sup> | -0.3  | 3.6 |      |
| Storage temperature, T <sub>STG</sub>     | -40   | 150 | °C   |

- (1) Stresses beyond those listed under *absolute maximum ratings* may cause permanent damage to the device. These are stress ratings only and functional operation of the device at these or any other conditions beyond those indicated under *recommended operating conditions* is not implied. Exposure to absolute-maximum-rated conditions for extended periods may affect device reliability.
- (2) All voltages referenced to GND.

## RECOMMENDED OPERATING CONDITIONS

over operating free-air temperature range (unless otherwise noted)

|                |   | MIN | TYP | MAX | UNIT |
|----------------|---|-----|-----|-----|------|
| V              | Supply voltage during operation, V33D, V33A | 3.0 | 3.3 | 3.6 | V    |
| T <sub>A</sub> | Operating free-air temperature range        | -40 |     | 110 | °C   |
| T <sub>J</sub> | Junction temperature                        |     |     | 110 |      |

## THERMAL INFORMATION

| THERMAL METRIC <sup>(1)</sup> |   | bq500412 |  |  | UNITS |
|-------------------------------|---|----------|--|--|-------|
|                               |   | RGZ      |  |  |       |
|                               |   | 48 PINS  |  |  |       |
| θ <sub>JA</sub>               | Junction-to-ambient thermal resistance <sup>(2)</sup>       | 28.4     |  |  | °C/W  |
| θ <sub>JCtop</sub>            | Junction-to-case (top) thermal resistance <sup>(3)</sup>    | 14.2     |  |  |       |
| θ <sub>JB</sub>               | Junction-to-board thermal resistance <sup>(4)</sup>         | 5.4      |  |  |       |
| ψ <sub>JT</sub>               | Junction-to-top characterization parameter <sup>(5)</sup>   | 0.2      |  |  |       |
| ψ <sub>JB</sub>               | Junction-to-board characterization parameter <sup>(6)</sup> | 5.3      |  |  |       |
| θ <sub>JCbot</sub>            | Junction-to-case (bottom) thermal resistance <sup>(7)</sup> | 1.4      |  |  |       |

- (1) For more information about traditional and new thermal metrics, see the *IC Package Thermal Metrics* application report, [SPRA953](#).
- (2) The junction-to-ambient thermal resistance under natural convection is obtained in a simulation on a JEDEC-standard, high-K board, as specified in JESD51-7, in an environment described in JESD51-2a.
- (3) The junction-to-case (top) thermal resistance is obtained by simulating a cold plate test on the package top. No specific JEDEC-standard test exists, but a close description can be found in the ANSI SEMI standard G30-88.
- (4) The junction-to-board thermal resistance is obtained by simulating in an environment with a ring cold plate fixture to control the PCB temperature, as described in JESD51-8.
- (5) The junction-to-top characterization parameter, ψ<sub>JT</sub>, estimates the junction temperature of a device in a real system and is extracted from the simulation data for obtaining θ<sub>JA</sub>, using a procedure described in JESD51-2a (sections 6 and 7).
- (6) The junction-to-board characterization parameter, ψ<sub>JB</sub>, estimates the junction temperature of a device in a real system and is extracted from the simulation data for obtaining θ<sub>JA</sub>, using a procedure described in JESD51-2a (sections 6 and 7).
- (7) The junction-to-case (bottom) thermal resistance is obtained by simulating a cold plate test on the exposed (power) pad. No specific JEDEC standard test exists, but a close description can be found in the ANSI SEMI standard G30-88.

## ELECTRICAL CHARACTERISTICS

over operating free-air temperature range (unless otherwise noted)

| PARAMETER  |  | TEST CONDITIONS                                    | MIN  | TYP            | MAX             | UNIT          |
|--|--|--|------|----------------|-----------------|---------------|
| <b>SUPPLY CURRENT</b>  |  |  |      |                |                 |               |
| $I_{V33A}$   | Supply current                           | V33A = 3.3 V                                       |      | 8              | 15              | mA            |
| $I_{V33D}$   |  | V33D = 3.3 V                                       |      | 44             | 55              |               |
| $I_{TOTAL}$  |  | V33D = V33A = 3.3 V                                |      | 52             | 60              |               |
| <b>INTERNAL REGULATOR CONTROLLER INPUTS/OUTPUTS</b>                                    |  |  |      |                |                 |               |
| V33  | 3.3-V linear regulator                   | Emitter of NPN transistor                          | 3.25 | 3.3            | 3.6             | V             |
| V33FB  | 3.3-V linear regulator feedback          |  |      | 4              | 4.6             |               |
| $I_{V33FB}$  | Series pass base drive                   | $V_{IN} = 12$ V; current into V33FB pin            |      | 10             |                 | mA            |
| Beta   | Series NPN pass device                   |  | 40   |                |                 |               |
| <b>EXTERNALLY SUPPLIED 3.3 V POWER</b>   |  |  |      |                |                 |               |
| V33D   | Digital 3.3-V power                      | $T_A = 25^\circ\text{C}$                           | 3    |                | 3.6             | V             |
| V33A   | Analog 3.3-V power                       | $T_A = 25^\circ\text{C}$                           | 3    |                | 3.6             |               |
| V33Slew  | V33 slew rate                            | V33 slew rate between 2.3 V and 2.9 V, V33A = V33D | 0.25 |                |                 | V/ms          |
| <b>DIGITAL DEMODULATION INPUTS COMM_A+, COMM_A-, COMM_B+, COMM_B-</b>                  |  |  |      |                |                 |               |
| $V_{bias}$   | COMM+ Bias Voltage                       |  |      | 1.0            |                 | V             |
| COMM+,<br>COMM-  | Modulation voltage digital resolution    |  |      | 1              |                 | mV            |
| $R_{EA}$   | Input impedance                          | Ground reference                                   | 0.5  | 1.5            | 3               | M $\Omega$    |
| $I_{OFFSET}$   | Input offset current                     | 1-k $\Omega$ source impedance                      | -5   |                | 5               | $\mu\text{A}$ |
| <b>ANALOG INPUTS V_SENSE, I_SENSE, T_SENSE, LED_MODE, LOSS_THR, SNOOZE_CAP, PWR_UP</b> |  |  |      |                |                 |               |
| $V_{ADDR\_OPEN}$   | Voltage indicating open pin              | LED_MODE open                                      | 2.37 |                |                 | V             |
| $V_{ADDR\_SHORT}$  | Voltage indicating pin shorted to GND    | LED_MODE shorted to ground                         |      |                | 0.36            |               |
| $V_{ADC\_RANGE}$   | Measurement range for voltage monitoring | ALL ANALOG INPUTS                                  | 0    |                | 2.5             |               |
| INL  | ADC integral nonlinearity                |  | -2.5 |                | 2.5             | mV            |
| $R_{IN}$   | Input impedance                          | Ground reference                                   | 8    |                |                 | M $\Omega$    |
| $C_{IN}$   | Input capacitance                        |  |      |                | 10              | pF            |
| <b>DIGITAL INPUTS/OUTPUTS</b>  |  |  |      |                |                 |               |
| $V_{OL}$   | Low-level output voltage                 | $I_{OL} = 6$ mA, V33D = 3 V                        |      |                | DGND1<br>+ 0.25 | V             |
| $V_{OH}$   | High-level output voltage                | $I_{OH} = -6$ mA, V33D = 3 V                       |      | V33D<br>- 0.6V |                 |               |
| $V_{IH}$   | High-level input voltage                 | V33D = 3V  | 2.1  |                | 3.6             |               |
| $V_{IL}$   | Low-level input voltage                  | V33D = 3.5 V                                       |      |                | 1.4             |               |
| $I_{OH}(MAX)$  | Output high source current               |  |      |                | 4               | mA            |
| $I_{OL}(MAX)$  | Output low sink current                  |  |      |                | 4               |               |
| <b>SYSTEM PERFORMANCE</b>  |  |  |      |                |                 |               |
| $V_{RESET}$  | Voltage where device comes out of reset  | V33D Pin   |      |                | 2.4             | V             |
| $t_{RESET}$  | Pulse width needed for reset             | RESET pin  | 2    |                |                 | $\mu\text{s}$ |
| $f_{SW}$   | Switching Frequency                      |  | 112  |                | 205             | kHz           |

DEVICE INFORMATION

Functional Block Diagram

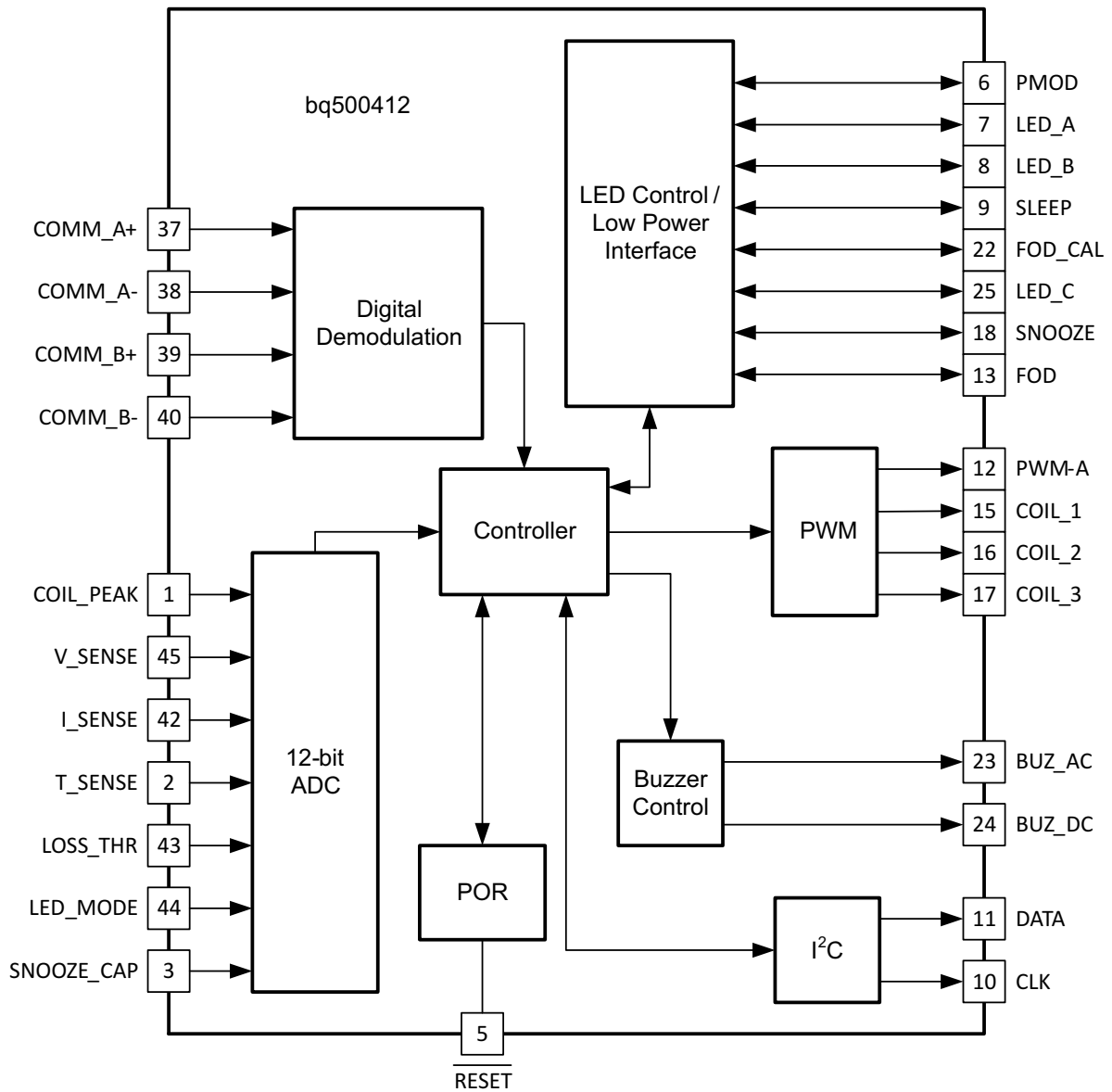

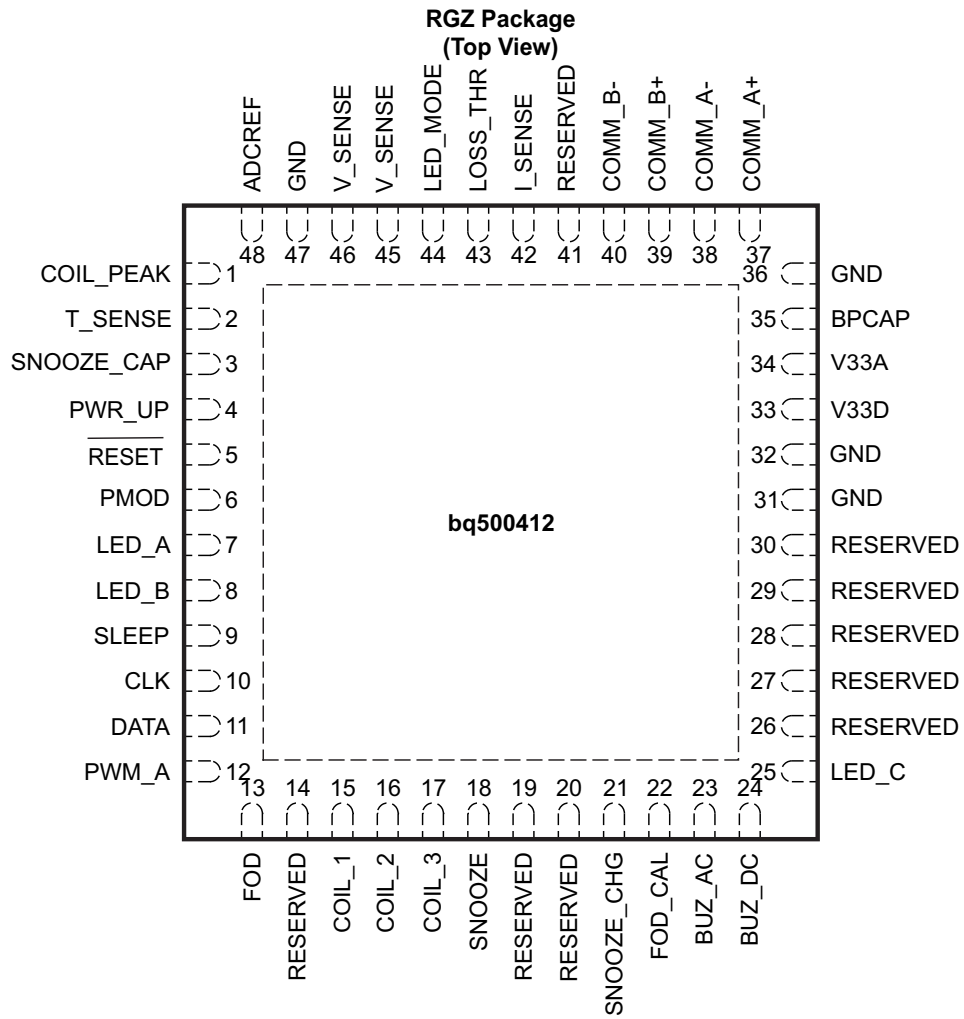

**PIN FUNCTIONS**

| PIN |            | I/O | DESCRIPTION  |
|-----|------------|-----|--|
| NO. | NAME       |     |  |
| 1   | COIL_PEAK  | I   | Connected to peak detect circuit. Protects from coil overvoltage event.  |
| 2   | T_SENSE    | I   | Sensor Input. Device shuts down when below 1 V for longer than 150ms. If not used, keep above 1 V by connecting to the 3.3-V supply. |
| 3   | SNOOZE_CAP | I   | Connected to interval timing capacitor   |
| 4   | PWR_UP     | I   | First power-up indicator   |
| 5   | RESET      | I   | Device reset. Use a 10-kΩ to 100-kΩ pull-up resistor to the 3.3-V supply.  |
| 6   | PMOD       | O   | Select for PMOD threshold  |
| 7   | LED_A      | I   | Connect to an LED via 470-Ω resistor for status indication. Typically GREEN  |
| 8   | LED_B      | I   | Connect to an LED via 470-Ω resistor for status indication. Typically RED  |
| 9   | SLEEP      | O   | Force SLEEP (5 sec low power)  |
| 10  | CLK        | I/O | 10-kΩ pull-up resistor to 3.3-V supply. Please contact field for GUI application assistance.   |
| 11  | DATA       | I/O | 10-kΩ pull-up resistor to 3.3-V supply. Please contact field for GUI application assistance.   |
| 12  | PWM_A      | O   | PWM Output A, controls one half of the full bridge in a phase-shifted full bridge. Switching deadtimes must be externally generated. |
| 13  | FOD        | O   | Select for FOD threshold   |
| 14  | RESERVED   | O   | Reserved. Leave open.  |
| 15  | COIL_1     | O   | Select first coil  |
| 16  | COIL_2     | O   | Select second coil   |
| 17  | COIL_3     | O   | Select third coil  |
| 18  | SNOOZE     | O   | Force SNOOZE (500ms low power)   |
| 19  | RESERVED   | O   | Reserved, leave this pin open.   |
| 20  | RESERVED   | I   | Reserved, connect to GND.  |
| 21  | SNOOZE_CHG | O   | Charge the snooze cap  |
| 22  | FOD_CAL    | O   | Select for FOD calibration resistor  |
| 23  | BUZ_AC     | O   | AC Buzzer Output. Outputs a 400-ms, 4-kHz AC pulse when charging begins.   |
| 24  | BUZ_DC     | O   | DC Buzzer Output. Outputs a 400-ms DC pulse when charging begins. This could also be connected to an LED via 470-Ω resistor.         |
| 25  | LED_C      | I/O | Connect to an LED via 470-Ω resistor for status indication. Typically YELLOW   |
| 26  | RESERVED   | I/O | Reserved, connect to GND.  |
| 27  | RESERVED   | I/O | Reserved, leave this pin open.   |
| 28  | RESERVED   | I/O | Reserved, leave this pin open.   |
| 29  | RESERVED   | I/O | Reserved, leave this pin open.   |
| 30  | RESERVED   | I/O | Reserved, leave this pin open.   |
| 31  | GND        | I/O | Reserved, connect to GND.  |

**PIN FUNCTIONS (continued)**

| PIN |          | I/O | DESCRIPTION  |
|-----|----------|-----|--|
| NO. | NAME     |     |  |
| 32  | GND      | —   | GND.   |
| 33  | V33D     | —   | Digital core 3.3-V supply. Be sure to decouple with bypass capacitors as close to the part as possible.                      |
| 34  | V33A     | —   | Analog 3.3-V Supply. This pin can be derived from V33D supply, decouple with 10-Ω resistor and additional bypass capacitors  |
| 35  | BPCAP    | —   | Bypass capacitor for internal 1.8-V core regulator. Connect bypass capacitor to GND.   |
| 36  | GND      | —   | GND.   |
| 37  | COMM_A+  | I   | Digital demodulation non-inverting input A, connect parallel to input B+.  |
| 38  | COMM_A-  | I   | Digital demodulation inverting input A, connect parallel to input B-.  |
| 39  | COMM_B+  | I   | Digital demodulation non-inverting input B, connect parallel to input A+.  |
| 40  | COMM_B-  | I   | Digital demodulation inverting input B, connect parallel to input A-.  |
| 41  | RESERVED | O   | Reserved, leave this pin open.   |
| 42  | I_SENSE  | I   | Transmitter input current, used for efficiency calculations. Use 20-mΩ sense resistor and A=50 gain current sense amplifier. |
| 43  | LOSS_THR | I   | Input to program FOD/PMOD thresholds and FOD_CAL correction.   |
| 44  | LED_MODE | I   | Input to select from four LED modes.   |
| 45  | V_SENSE  | I   | Transmitter input voltage, used for efficiency calculations. Use 76.8-kΩ to 10-kΩ divider to minimize quiescent current.     |
| 46  | V_IN     | I   | System input voltage, used for DPL. Use 76.8-kΩ to 10-kΩ divider to minimize quiescent current.                              |
| 47  | GND      | —   | GND.   |
| 48  | ADCREP   | I   | External Reference Voltage Input. Connect this input to GND.   |
| 49  | EPAD     | —   | Flood with copper GND plane and stitch vias to PCB internal GND plane.   |

## Principles of Operation

### Fundamentals

The principle of wireless power transfer is simply an open cored transformer consisting of primary and secondary coils and associated electronics. The primary coil and electronics are also referred to as the transmitter, and the secondary side the receiver. The transmitter coil and electronics are typically built into a charger pad. The receiver coil and electronics are typically built into a portable device, such as a cell-phone.

When the receiver coil is positioned on the transmitter coil, magnetic coupling occurs when the transmitter coil is driven. The flux is coupled into the secondary coil which induces a voltage, current flows, it is rectified and power can be transferred quite effectively to a load - wirelessly. Power transfer can be managed via any of various familiar closed-loop control schemes.

### Wireless Power Consortium (WPC)

The Wireless Power Consortium (WPC) is an international group of companies from diverse industries. The WPC standard was developed to facilitate cross compatibility of compliant transmitters and receivers. The standard defines the physical parameters and the communication protocol to be used in wireless power. For more information, go to [www.wirelesspowerconsortium.com](http://www.wirelesspowerconsortium.com).

### Power Transfer

Power transfer depends on coil coupling. Coupling is dependent on the distance between coils, alignment, coil dimensions, coil materials, number of turns, magnetic shielding, impedance matching, frequency and duty cycle.

Most importantly, the receiver and transmitter coils must be aligned for best coupling and efficient power transfer. The closer the space between the coils, the better the coupling, but the practical distance is set to be less than 5 mm (as defined within the WPC Specification) to account for housing and interface surfaces.

Shielding is added as a backing to both the transmitter and receiver coils to direct the magnetic field to the coupled zone. Magnetic fields outside the coupled zone do not transfer power. Thus, shielding also serves to contain the fields to avoid coupling to other adjacent system components.

Regulation can be achieved by controlling any one of the coil coupling parameters. For WPC compatibility, the transmitter coils and capacitance are specified and the resonant frequency point is fixed. Power transfer is regulated by changing the operating frequency between 120 kHz to 205 kHz. The higher the frequency, the further from resonance and the lower the power. Duty cycle remains constant at 50% throughout the power band and is reduced only once 205 kHz is reached.

The WPC standard describes the dimension and materials of the coils. It also has information on tuning the coils to resonance. The value of the inductor and resonant capacitor are critical to proper operation and system efficiency.

## Communication

Communication within the WPC is from the receiver to the transmitter, where the receiver tells the transmitter to send power and how much. In order to regulate, the receiver must communicate with the transmitter whether to increase or decrease frequency. The receiver monitors the rectifier output and using Amplitude Modulation (AM), sends packets of information to the transmitter. A packet is comprised of a preamble, a header, the actual message and a checksum, as defined by the WPC standard.

The receiver sends a packet by modulating an impedance network. This AM signal reflects back as a change in the voltage amplitude on the transmitter coil. The signal is demodulated and decoded by the transmitter side electronics and the frequency of its coil drive output is adjusted to close the regulation loop. The bq500412 features internal digital demodulation circuitry.

The modulated impedance network on the receiver can either be resistive or capacitive. [Figure 1](#) shows the resistive modulation approach, where a resistor is periodically added to the load and also shows the resulting change in resonant curve which causes the amplitude change in the transmitter voltage indicated by the two operating points at the same frequency. [Figure 2](#) shows the capacitive modulation approach, where a capacitor is periodically added to the load and also shows the resulting amplitude change in the transmitter voltage.

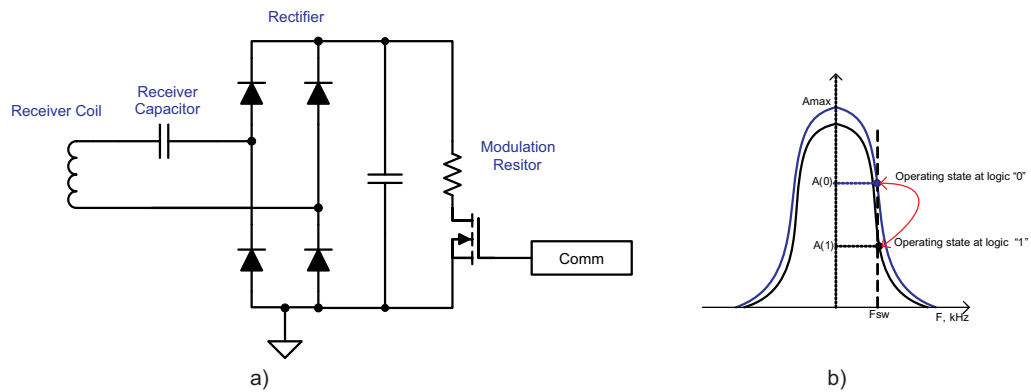

**Figure 1. Receiver Resistive Modulation Circuit**

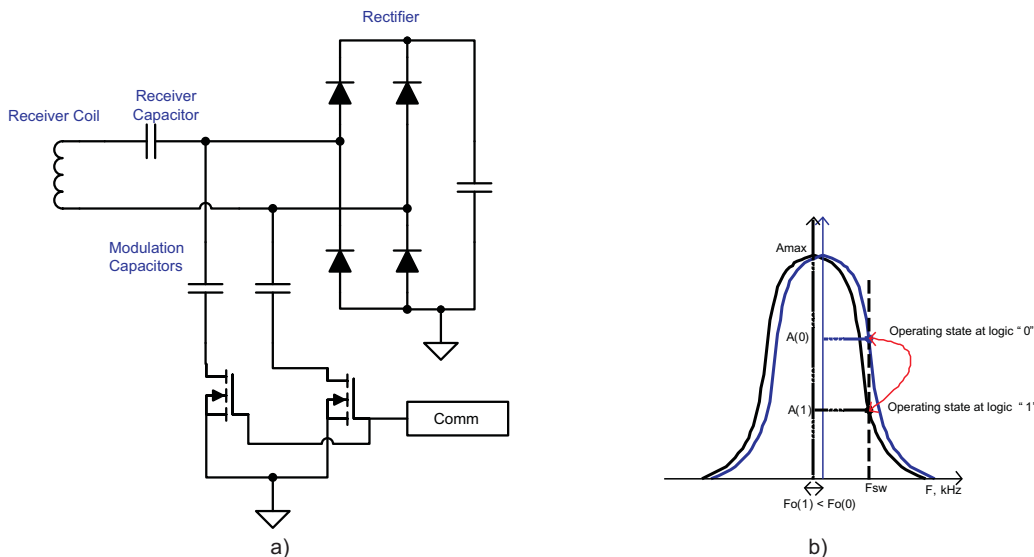

**Figure 2. Receiver Capacitive Modulation Circuit**

## Application Information

### Coils and Matching Capacitors

The coil and matching capacitor selection for the transmitter has been established by WPC standard. These values are fixed and cannot be changed on the transmitter side.

An up to date list of available and compatible A6 transmitter coils can be found here ([Texas Instruments Literature Number SLUA649](#)):

Capacitor selection is critical to proper system operation. The total capacitance value of 147nF is required in the center coil of the resonant tank. This capacitance is not a standard value and therefore several must be combined in parallel. It is recommended to use 100nF + 47nF, as these are very commonly available.

---

#### NOTE

A total capacitance value of 147nF/100 V/COG is required in the center coil and 133nF/100V/COG in the side coils of the resonant tank to achieve the desired resonance frequency.

---

The capacitors chosen must be rated for 100 V operation. Use quality COG type dielectric capacitors from reputable vendors such as KEMET, MURATA or TDK.

### Dynamic Power Limiting™

With an optional 5-V to 12-V boost converter, a 5-V input can enable a 12-V WPC A6 transmitter. The Dynamic Power Limiting™ (DPL) feature allows operation from a 5-V supply with limited current capability (such as a USB port). When the 5-V input voltage is observed drooping, the output power is dynamically limited to reduce the load and provides margin relative to the supply's capability.

Anytime the DPL control loop is regulating the operating point of the transmitter, the LED will indicate that DPL is active. The LED color and flashing pattern are determined by the LED Table. If the receiver sends a Control Error Packet (CEP) with a negative value, (for example, to reduce power to the load), the transmitter in DPL mode will respond to this CEP via the normal WPC control loop.

---

#### NOTE

The power limit indication depends on the LED\_MODE selected.

---

## Option Select Pins

Several pins on the bq500412 are allocated to programming the FOD and PMOD Loss Threshold and the LED mode of the device. At power up, a bias current is applied to pins LED\_MODE and LOSS\_THR and the resulting voltage measured in order to identify the value of the attached programming resistor. FOD, PMOD and FOD\_CAL pin values are enabled and read sequentially from the same LOSS\_THR bias current. The values of the operating parameters set by these pins are determined using [Table 2](#). For LED\_MODE, the selected bin determines the LED behavior based on [Table 1](#); for the LOSS\_THR, the selected bin sets a threshold used for parasitic metal object detection (see Parasitic Metal Detection (PMOD) and Foreign Object Detection (FOD) section). [Table 1](#).

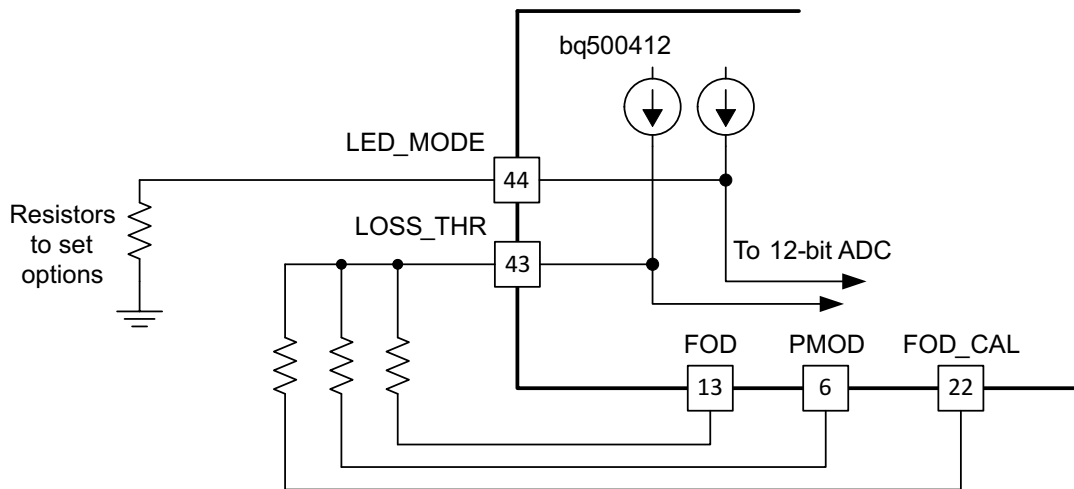

**Figure 3. Option Select Pin Programming**

## LED Indication Modes

The bq500412 can directly drive up to three (3) LED outputs (pin 7, pin 8 and pin 25) through a simple current limit resistor (typically 470  $\Omega$ ), based on the mode selected. The current limit resistors can be individually adjusted to tune or match the brightness of the LEDs. Do not exceed the maximum output current rating of the device. The resistor in [Figure 3](#) connected to pin 44 and GND selects the desired LED indication scheme in [Table 1](#).

- LED modes permit the use of one to three indicator LED's. Amber in the 2-LED mode is obtained by turning on both the green and red.
- LEDs can be turned on solid or configured to blink either slow (approx. 1.6s period) or fast (approx. 400ms period).
- Except in modes 2 and 9, the charge complete state is only maintained for 5 seconds after which it reverts to idle. This permits the processor to sleep in order to reduce standby power consumption. In other modes, external logic, such as a flip-flop, may be implemented to maintain the charge complete indication if desired.
- LED modes 5 and 8 will display a sequence of red-amber-green, for 0.5 seconds when the device is first powered up.

**Table 1. LED Modes**

| LED CONTROL OPTION | LED SELECTION RESISTOR | DESCRIPTION          | LED         | OPERATIONAL STATES |                |                 |            |                         |             |
|--------------------|------------------------|----------------------|-------------|--------------------|----------------|-----------------|------------|-------------------------|-------------|
|                    |                        |                      |             | STANDBY            | POWER TRANSFER | CHARGE COMPLETE | FAULT      | DYNAMIC POWER LIMITING™ | FOD Warning |
| X                  | < 36.5 kΩ              | Reserved, do not use | LED1, green | -                  | -              | -               | -          | -                       | -           |
|                    |                        |                      | LED2, red   | -                  | -              | -               | -          | -                       | -           |
|                    |                        |                      | LED3, amber | -                  | -              | -               | -          | -                       | -           |
| 1                  | 42.2 kΩ                | Choice number 1      | LED1, green | Off                | Blink slow     | On              | Off        | Blink slow              | Off         |
|                    |                        |                      | LED2, red   | Off                | Off            | Off             | On         | Blink slow              | Blink fast  |
|                    |                        |                      | LED3, amber | -                  | -              | -               | -          | -                       | -           |
| 2                  | 48.7 kΩ                | Choice number 2      | LED1, green | On                 | Blink slow     | On              | Off        | Blink slow              | Off         |
|                    |                        |                      | LED2, red   | On                 | Off            | Off             | On         | Blink slow              | Blink fast  |
|                    |                        |                      | LED3, amber | -                  | -              | -               | -          | -                       | -           |
| 3                  | 56.2 kΩ                | Choice number 3      | LED1, green | Off                | On             | Off             | Blink fast | On                      | On          |
|                    |                        |                      | LED2, red   | -                  | -              | -               | -          | -                       | -           |
|                    |                        |                      | LED3, amber | -                  | -              | -               | -          | -                       | -           |
| 4                  | 64.9 kΩ                | Choice number 4      | LED1, green | Off                | On             | Off             | Off        | Off                     | Off         |
|                    |                        |                      | LED2, red   | Off                | Off            | Off             | On         | Blink slow              | Blink fast  |
|                    |                        |                      | LED3, amber | -                  | -              | -               | -          | -                       | -           |
| 5                  | 75 kΩ                  | Choice number 5      | LED1, green | Off                | Off            | On              | Off        | Off                     | Off         |
|                    |                        |                      | LED2, red   | Off                | On             | Off             | Off        | On                      | On          |
|                    |                        |                      | LED3, amber | Off                | Off            | Off             | Blink slow | Off                     | Off         |
| 6                  | 86.6 kΩ                | Choice number 6      | LED1, green | Off                | Blink slow     | On              | Off        | Off                     | Off         |
|                    |                        |                      | LED2, red   | Off                | Off            | Off             | On         | Off                     | Blink fast  |
|                    |                        |                      | LED3, amber | Off                | Off            | Off             | Off        | Blink Slow              | Off         |
| 7                  | 100 kΩ                 | Choice number 7      | LED1, green | Off                | Blink slow     | Off             | Off        | Off                     | Off         |
|                    |                        |                      | LED2, red   | Off                | Off            | On              | Off        | Off                     | Off         |
|                    |                        |                      | LED3, amber | Off                | Off            | Off             | On         | Blink slow              | Blink fast  |
| 8                  | 115 kΩ                 | Choice number 8      | LED1, green | Off                | Off            | On              | Blink slow | Off                     | Off         |
|                    |                        |                      | LED2, red   | Off                | On             | Off             | Blink slow | On                      | On          |
|                    |                        |                      | LED3, amber | -                  | -              | -               | -          | -                       | -           |
| 9                  | 133 kΩ                 | Choice number 9      | LED1, green | Off                | Blink slow     | On              | Off        | Blink slow              | Off         |
|                    |                        |                      | LED2, red   | Off                | Off            | Off             | On         | Blink slow              | Blink fast  |
|                    |                        |                      | LED3, amber | -                  | -              | -               | -          | -                       | -           |
| 10                 | 154 kΩ                 | Choice number 10     | LED1, green | Off                | On             | Off             | Blink fast | Blink slow              | On          |
|                    |                        |                      | LED2, red   | Off                | Off            | On              | Off        | Off                     | Off         |
|                    |                        |                      | LED3, amber | -                  | -              | -               | -          | -                       | -           |

## Parasitic Metal Object Detect (PMOD), Foreign Object Detection (FOD) and FOD Calibration

The bq500412 supports improved FOD (WPC1.1) and enhanced PMOD (WPC 1.0) features. Continuously monitoring input power, known losses, and the value of power reported by the RX device being charged, the bq500412 can estimate how much power is unaccounted for and presumed lost due to metal objects placed in the wireless power transfer path. If this unexpected loss exceeds the threshold set by the FOD or PMOD resistors, a fault is indicated and power transfer is halted. Whether the FOD or the PMOD algorithm is used is determined by the ID packet of the receiver being charged.

As the default, both PMOD and FOD resistors should set a threshold of 400 mW (selected by 56.2-k $\Omega$  resistors from FOD (pin 13) and PMOD(pin 6) to LOSS\_THR (pin43)). 400 mW has been empirically determined using standard WPC FOD test objects (disc, ring and foil). Some tuning might be required as every system will be slightly different. The ultimate goal of the FOD feature is safety; to protect misplaced metal objects from becoming hot. Reducing the loss threshold and making the system too sensitive will lead to false trips and a bad user experience. Find the balance which best suits the application.

If the application requires disabling one function or the other (or both), it is possible by leaving the respective FOD/PMOD pin open. For example, to selectively disable the PMOD function, PMOD (pin16) should be left open.

### NOTE

Disabling FOD results in a TX solution that is not WPC compliant.

Resistors of 1% tolerance should be used for a reliable selection of the desired threshold.

The FOD and PMOD resistors (pin 13 and pin 6) program the permitted power loss for the FOD and PMOD algorithms respectively. The FOD\_CAL resistor (pin 22), can be used to compensate for any load dependent effect on the power loss. Using a calibrated test receiver with no foreign objects present, the FOD\_CAL resistor should be selected such that the calculated loss across the load range is substantially constant (within ~100 mW). After correcting for the load dependence, the FOD and PMOD thresholds should be re-set above the resulting average by approximately 400 mW in order for the transmitter to satisfy the WPC requirements on tolerated heating.

Please contact TI for more information about setting appropriate FOD, PMOD, and FOD\_CAL resistor values for your design.

**Table 2. Option Select Bins**

| BIN NUMBER | RESISTANCE (k $\Omega$ ) | LOSS THRESHOLD (mW) |
|------------|--------------------------|---------------------|
| 0          | <36.5                    | 250                 |
| 1          | 42.2                     | 300                 |
| 2          | 48.7                     | 350                 |
| 3          | 56.2                     | 400                 |
| 4          | 64.9                     | 450                 |
| 5          | 75.0                     | 500                 |
| 6          | 86.6                     | 550                 |
| 7          | 100                      | 600                 |
| 8          | 115                      | 650                 |
| 9          | 133                      | 700                 |
| 10         | 154                      | 750                 |
| 11         | 178                      | 800                 |
| 12         | 205                      | 850                 |
| 13         | >237                     | Feature Disabled    |

## Shut Down via External Thermal Sensor or Trigger

Typical applications of the bq500412 will not require additional thermal protection. This shutdown feature is provided for enhanced applications and is not only limited to thermal shutdown. The key parameter is the 1.0 V threshold on pin 2. Voltage below 1.0 V on pin 2 for longer than 150ms causes the device to shutdown.

The application of thermal monitoring via a Negative Temperature Coefficient (NTC) sensor, for example, is straightforward. The NTC forms the lower leg of a temperature dependant voltage divider. The NTC leads are connected to the bq500412 device, pin 2 and GND. The threshold on pin 2 is set to 1.0 V, below which the system shuts down and a fault is indicated (depending on LED mode chosen).

To implement this feature follow these steps:

- 1) Consult the NTC datasheet and find the resistance vs temperature curve.
- 2) Determine the actual temperature where the NTC will be placed by using a thermal probe.
- 3) Read the NTC resistance at that temperature in the NTC datasheet, that is  $R_{NTC}$ .
- 4) Use the following formula to determine the upper leg resistor ( $R_{Setpoint}$ ):

$$R_{Setpoint} = 2.3 \times R_{NTC} \tag{1}$$

The system will restore normal operation after approximately five minutes or if the receiver is removed. If the feature is not used, this pin must be pulled high.

### NOTE

Pin 2 must always be terminated, else erratic behavior may result.

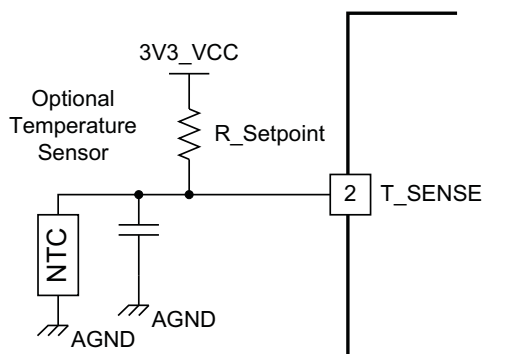

Figure 4. Negative Temperature Coefficient (NTC) Application

## Fault Handling and Indication

The following table provides **approximate** durations for the time before a retry is attempted for End Power Transfer (EPT) packets and fault events. Precise timing may be affected by external components, or may be shortened by receiver removal. The LED mode selected determines how the LED indicates the condition or fault.

| CONDITION             | DURATION<br>(before retry) | HANDLING  |
|-----------------------|----------------------------|---|
| EPT-00                | Immediate                  | Unknown   |
| EPT-01                | 5 seconds                  | Charge complete                                   |
| EPT-02                | 5 seconds                  | Internal fault                                    |
| EPT-03                | 5 minutes                  | temperature                                       |
| EPT-04                | Immediate Over             | voltage   |
| EPT-05                | Immediate Over             | current   |
| EPT-06                | 5 seconds                  | failure   |
| EPT-07                | Not applicable             | Reconfiguration                                   |
| EPT-08                | Immediate                  | No response                                       |
| OC (over current)     | 1 minute                   |   |
| NTC (external sensor) | 5 minutes                  |   |
| PMOD/FOD warning      | 12 seconds                 | 10 seconds LED only,<br>2 seconds LED +<br>buzzer |
| PMOD/FOD              | 5 minutes                  |   |

## Power Transfer Start Signal

The bq500412 features two signal outputs to indicate that power transfer has begun. Pin 23 outputs a 400-ms duration, 4-kHz square wave for driving low cost AC type ceramic buzzers. Pin 24 outputs logic high, also for 400 ms, which is suitable for DC type buzzers with built-in tone generators, or as a trigger for any type of customized indication scheme. If not used, these pins can be left open.

## Power-On Reset

The bq500412 has an integrated Power-On Reset (POR) circuit which monitors the supply voltage and handles the correct device startup sequence. Additional supply voltage supervisor or reset circuits are not needed.

## External Reset, $\overline{\text{RESET}}$ Pin

The bq500412 can be forced into a reset state by an external circuit connected to the  $\overline{\text{RESET}}$  pin. A logic low voltage on this pin holds the device in reset. For normal operation, this pin is pulled up to 3.3 V<sub>CC</sub> with a 10-kΩ pull-up resistor.

## Low Power Mode, SNOOZE

During standby, when nothing is on the transmitter pad, the bq500412 pings the surrounding environment at fixed intervals. The ping interval can be adjusted; the component values selected for the SNOOZE circuit determine this interval between pings. Time for SNOOZE is set by an RC time constant controlling the Enable of a 3.3V LDO. The LDO will remove 3.3V from the bq500412 to reduce power. The choice of the ping interval effects two quantities: the idle efficiency of the system, and the time required to detect the presence of a receiver when it is placed on the pad. A trade off should be made which balances low power (longest ping interval) with good user experience (quick detection through short ping interval) while still meeting the WPC requirement for detection within 0.5 seconds. Typical RC time constant values for the SNOOZE circuit are 392k ohms and 4.7uF. The value can be adjusted to increase or decrease the ping interval.

The system power consumption is approximately 300 mW during an active ping of all three coils, which lasts approximately 210 ms, and 40 mW for the balance of the cycle. A weighted average can thus be used to estimate the overall system's idle consumption:

If T<sub>ping</sub> is the interval between pings in ms, P<sub>idle</sub> in mW is approximately:

$$(40 \times (T_{\text{ping}} - 210) + 300 \times 210) / T_{\text{ping}} \quad (2)$$

## Trickle Charge and CS100

The WPC specification provides an End-of-Power Transfer message (EPT-01) to indicate charge complete. Upon receipt of the charge complete message, the bq500412 will change the LED indication. The exact indication depends on the LED\_MODE chosen.

In some battery charging applications there is a benefit to continue the charging process in trickle-charge mode to top off the battery. There are several information packets in the WPC specification related to the levels of battery charge (Charge Status). The bq500412 uses these commands to enable top-off charging. The bq500412 changes the LED indication to reflect charge complete when a Charge Status message is 100% received, but unlike the response to an EPT, it will not halt power transfer while the LED is solid green. The mobile device can use a CS100 packet to enable trickle charge mode.

If the reported charge status drops below 90% normal, charging indication will be resumed.

## Current Monitoring Requirements

The bq500412 is WPC1.1 ready. In order to enable the FOD or PMOD features, current monitoring circuitry must be provided in the application design.

For proper scaling of the current monitor signal, the current sense resistor should be 20 mΩ and the current shunt amplifier should have a gain of 50, such as the INA199A1. For FOD accuracy, the current sense resistor must be a quality component with 1% tolerance, at least 1/4-Watt rating, and a temperature stability of ±200 PPM. Proper current sensing techniques in the application hardware should also be observed.

If WPC compliance is not required current monitoring can be omitted. Connect the I\_SENSE pin (pin 42) to GND.

## All Unused Pins

All unused pins can be left open unless otherwise indicated. Pin 4 can be tied to GND and flooded with copper to improve ground shielding. Please refer to the pin definition table for further explanations.

## Design Checklist for WPC1.1 Compliance with the bq500412

- Coil and capacitor selection matches the A6 specification.
- Total 147-nF center and 133-nF side coil resonant capacitor requirement is met.
- Precision current sense amp used, such as the INA199A1. This is required for accurate FOD operation.
- Current shunt resistor 1% and <200 PPM. This is required for accurate FOD operation.

**APPLICATION INFORMATION**

**Overview**

The application block diagram for the transmitter with reduced standby power is shown in Figure 5. Below are some notes on parts selection.

**CAUTION**

Please check the bq500412 product page for the most up-to-date application schematic and list of materials package before starting a new design.

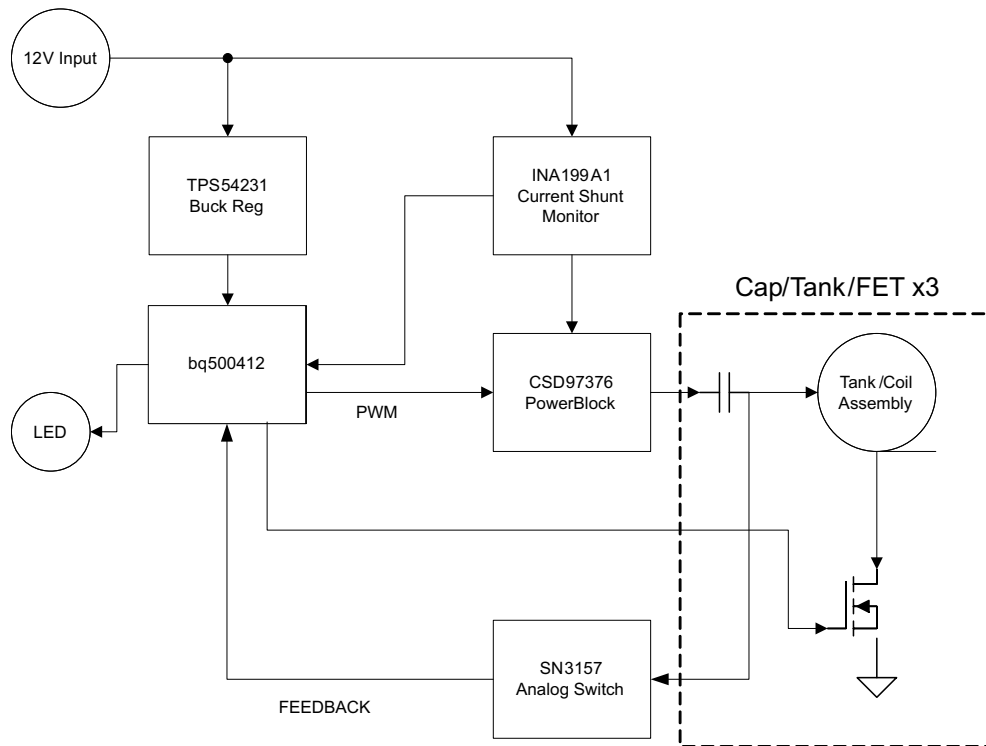

**Figure 5. bq500412 System Diagram**

## Input Regulator

The bq500412 requires 3.3 VDC to operate. A buck regulator or a linear regulator can be used to step down from the 12-V system input. Either choice is fully WPC compatible, the decision lies in the user's requirements with respect to cost versus efficiency. A buck regulator will offer higher efficiency and although slightly higher cost, it is typically the better choice.

## Power Train

The bq500412 drives three half bridges and only one of these bridges is activated at a time.

## PCB Layout

A good PCB layout is critical to proper system operation and due care should be taken. There are many references on proper PCB layout techniques.

Generally speaking, the system layout will require a 4-layer PCB layout, although a 2-layer PCB layout can be achieved. A proven and recommended approach to the layer stack-up has been:

- Layer 1, component placement and as much ground plane as possible.
- Layer 2, clean ground.
- Layer 3, finish routing.
- Layer 4, clean ground.

Thus, the circuitry is virtually sandwiched between grounds. This minimizes EMI noise emissions and also provides a noise free voltage reference plane for device operation.

Keep as much copper as possible. Make sure the bq500412 GND pins and the power pad have a continuous flood connection to the ground plane. The power pad should also be stitched to the ground plane, which also acts as a heat sink for the bq500412. A good GND reference is necessary for proper bq500412 operation, such as analog-digital conversion, clock stability and best overall EMI performance.

Separate the analog ground plane from the power ground plane and use only one tie point to connect grounds. Having several tie points defeats the purpose of separating the grounds.

The COMM return signal from the resonant tank should be routed as a differential pair. This is intended to reduce stray noise induction. The frequencies of concern warrant low-noise analog signaling techniques, such as differential routing and shielding, but the COMM signal lines do not need to be impedance matched.

Typically a single chip controller solution with integrated power FET and synchronous rectifier will be used. To create a tight loop, pull in the buck inductor and power loop as close as possible. Likewise, the power-train, full-bridge components should be pulled together as tight as possible. See the bq500412EVM-550, bqTESLA Wireless Power TX EVM User's Guide ([Texas Instruments Literature Number SLVU536](#)) for layout examples.

## References

1. *Building a Wireless Power Transmitter*, Application Report, ([Texas Instruments Literature Number, SLUA635](#))
2. *Technology*, Wireless Power Consortium, [www.wirelesspowerconsortium.com](http://www.wirelesspowerconsortium.com)
3. *An Introduction to the Wireless Power Consortium Standard and TI's Compliant Solutions*, ([Johns Bill, Texas Instruments](#))
4. *Integrated Wireless Power Supply Receiver, Qi (Wireless Power Consortium)*, BQ51013 Datasheet, ([Texas Instruments Literature Number, SLUSAY6](#))

## REVISION HISTORY

| Changes from Original (November, 2013) to Revision A                     | Page |
|--|------|
| • Changed marketing status from Product Preview to Production Data. .... | 1    |
| • Changed System Diagram drawing. ....                                   | 1    |
| • Changed COMM+ Bias Voltage from 1.5 V to 1.0 V. ....                   | 4    |
| • Changed Block Diagram. ....  | 5    |
| • Changed pinout drawing with updated pin names. ....                    | 6    |

**PACKAGING INFORMATION**

| Orderable Device | Status<br>(1) | Package Type | Package Drawing | Pins | Package Qty | Eco Plan<br>(2)         | Lead/Ball Finish<br>(6) | MSL Peak Temp<br>(3) | Op Temp (°C) | Device Marking<br>(4/5) | Samples |
|------------------|---------------|--------------|-----------------|------|-------------|-------------------------|-------------------------|----------------------|--------------|-------------------------|---------|
| BQ500412RGZR     | NRND          | VQFN         | RGZ             | 48   | 2500        | Green (RoHS & no Sb/Br) | CU NIPDAU               | Level-3-260C-168 HR  | 0 to 0       | BQ500412                |         |
| BQ500412RGZT     | NRND          | VQFN         | RGZ             | 48   | 250         | Green (RoHS & no Sb/Br) | CU NIPDAU               | Level-3-260C-168 HR  | 0 to 0       | BQ500412                |         |

(1) The marketing status values are defined as follows:

**ACTIVE:** Product device recommended for new designs.

**LIFEBUY:** TI has announced that the device will be discontinued, and a lifetime-buy period is in effect.

**NRND:** Not recommended for new designs. Device is in production to support existing customers, but TI does not recommend using this part in a new design.

**PREVIEW:** Device has been announced but is not in production. Samples may or may not be available.

**OBSOLETE:** TI has discontinued the production of the device.

(2) **RoHS:** TI defines "RoHS" to mean semiconductor products that are compliant with the current EU RoHS requirements for all 10 RoHS substances, including the requirement that RoHS substance do not exceed 0.1% by weight in homogeneous materials. Where designed to be soldered at high temperatures, "RoHS" products are suitable for use in specified lead-free processes. TI may reference these types of products as "Pb-Free".

**RoHS Exempt:** TI defines "RoHS Exempt" to mean products that contain lead but are compliant with EU RoHS pursuant to a specific EU RoHS exemption.

**Green:** TI defines "Green" to mean the content of Chlorine (Cl) and Bromine (Br) based flame retardants meet JS709B low halogen requirements of <=1000ppm threshold. Antimony trioxide based flame retardants must also meet the <=1000ppm threshold requirement.

(3) MSL, Peak Temp. - The Moisture Sensitivity Level rating according to the JEDEC industry standard classifications, and peak solder temperature.

(4) There may be additional marking, which relates to the logo, the lot trace code information, or the environmental category on the device.

(5) Multiple Device Markings will be inside parentheses. Only one Device Marking contained in parentheses and separated by a "~" will appear on a device. If a line is indented then it is a continuation of the previous line and the two combined represent the entire Device Marking for that device.

(6) Lead/Ball Finish - Orderable Devices may have multiple material finish options. Finish options are separated by a vertical ruled line. Lead/Ball Finish values may wrap to two lines if the finish value exceeds the maximum column width.

**Important Information and Disclaimer:**The information provided on this page represents TI's knowledge and belief as of the date that it is provided. TI bases its knowledge and belief on information provided by third parties, and makes no representation or warranty as to the accuracy of such information. Efforts are underway to better integrate information from third parties. TI has taken and continues to take reasonable steps to provide representative and accurate information but may not have conducted destructive testing or chemical analysis on incoming materials and chemicals. TI and TI suppliers consider certain information to be proprietary, and thus CAS numbers and other limited information may not be available for release.

In no event shall TI's liability arising out of such information exceed the total purchase price of the TI part(s) at issue in this document sold by TI to Customer on an annual basis.



**TAPE AND REEL INFORMATION**

**QUADRANT ASSIGNMENTS FOR PIN 1 ORIENTATION IN TAPE**

\*All dimensions are nominal

| Device       | Package Type | Package Drawing | Pins | SPQ  | Reel Diameter (mm) | Reel Width W1 (mm) | A0 (mm) | B0 (mm) | K0 (mm) | P1 (mm) | W (mm) | Pin1 Quadrant |
|--------------|--------------|-----------------|------|------|--------------------|--------------------|---------|---------|---------|---------|--------|---------------|
| BQ500412RGZR | VQFN         | RGZ             | 48   | 2500 | 330.0              | 16.4               | 7.3     | 7.3     | 1.1     | 12.0    | 16.0   | Q2            |
| BQ500412RGZT | VQFN         | RGZ             | 48   | 250  | 180.0              | 16.4               | 7.3     | 7.3     | 1.1     | 12.0    | 16.0   | Q2            |

TAPE AND REEL BOX DIMENSIONS



\*All dimensions are nominal

| Device       | Package Type | Package Drawing | Pins | SPQ  | Length (mm) | Width (mm) | Height (mm) |
|--------------|--------------|-----------------|------|------|-------------|------------|-------------|
| BQ500412RGZR | VQFN         | RGZ             | 48   | 2500 | 367.0       | 367.0      | 38.0        |
| BQ500412RGZT | VQFN         | RGZ             | 48   | 250  | 210.0       | 185.0      | 35.0        |

## GENERIC PACKAGE VIEW

**RGZ 48**

**VQFN - 1 mm max height**

7 x 7, 0.5 mm pitch

PLASTIC QUADFLAT PACK- NO LEAD

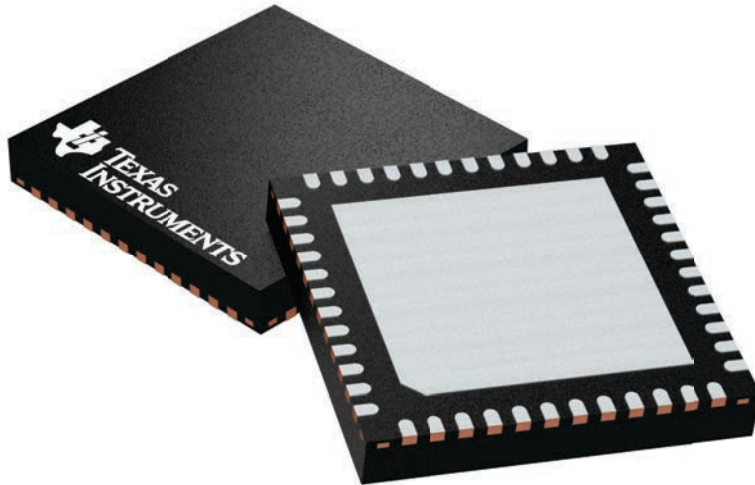

Images above are just a representation of the package family, actual package may vary.  
Refer to the product data sheet for package details.

4224671/A

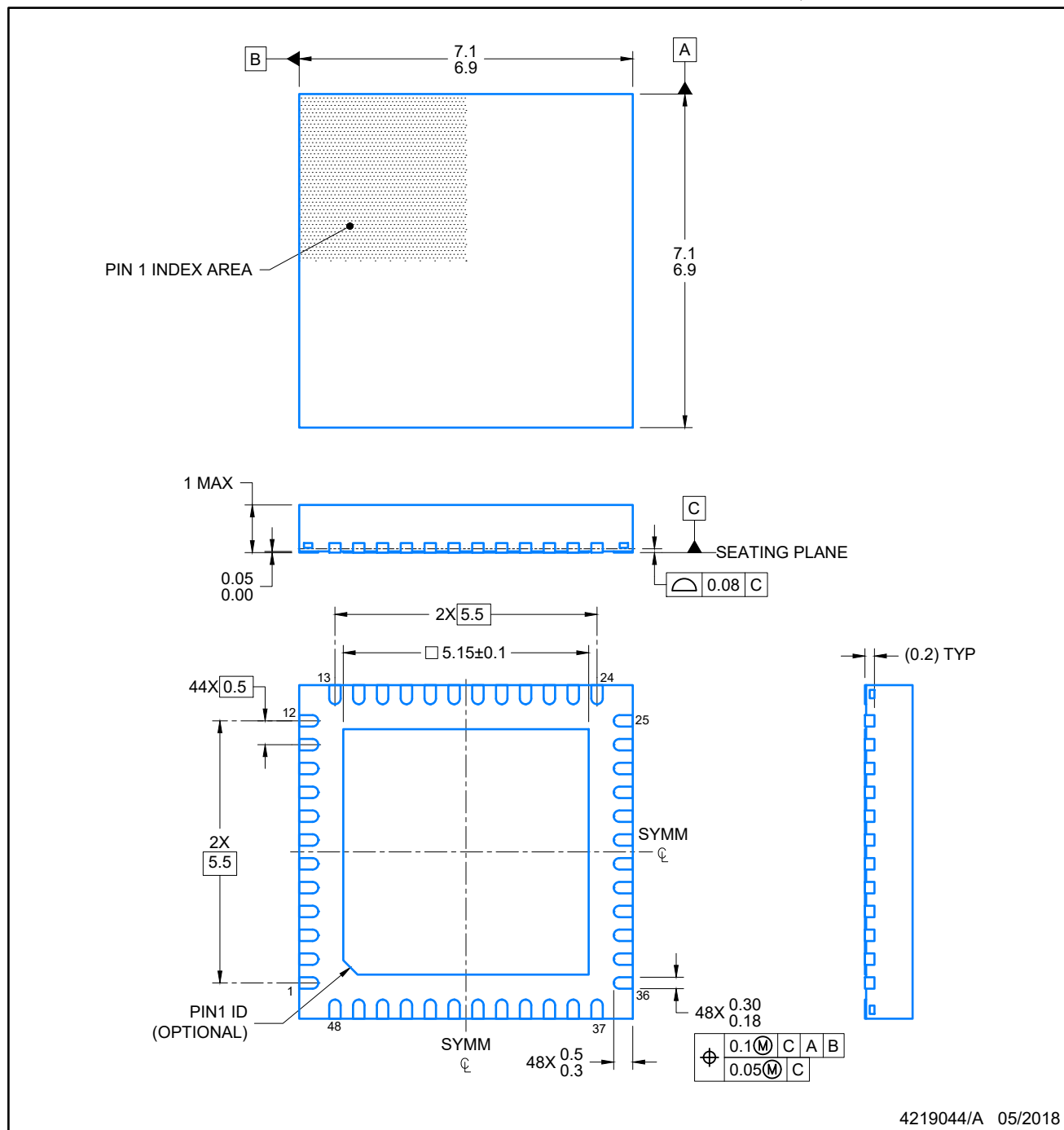

4219044/A 05/2018

NOTES:

1. All linear dimensions are in millimeters. Any dimensions in parenthesis are for reference only. Dimensioning and tolerancing per ASME Y14.5M.
2. This drawing is subject to change without notice.
3. The package thermal pad must be soldered to the printed circuit board for optimal thermal and mechanical performance.

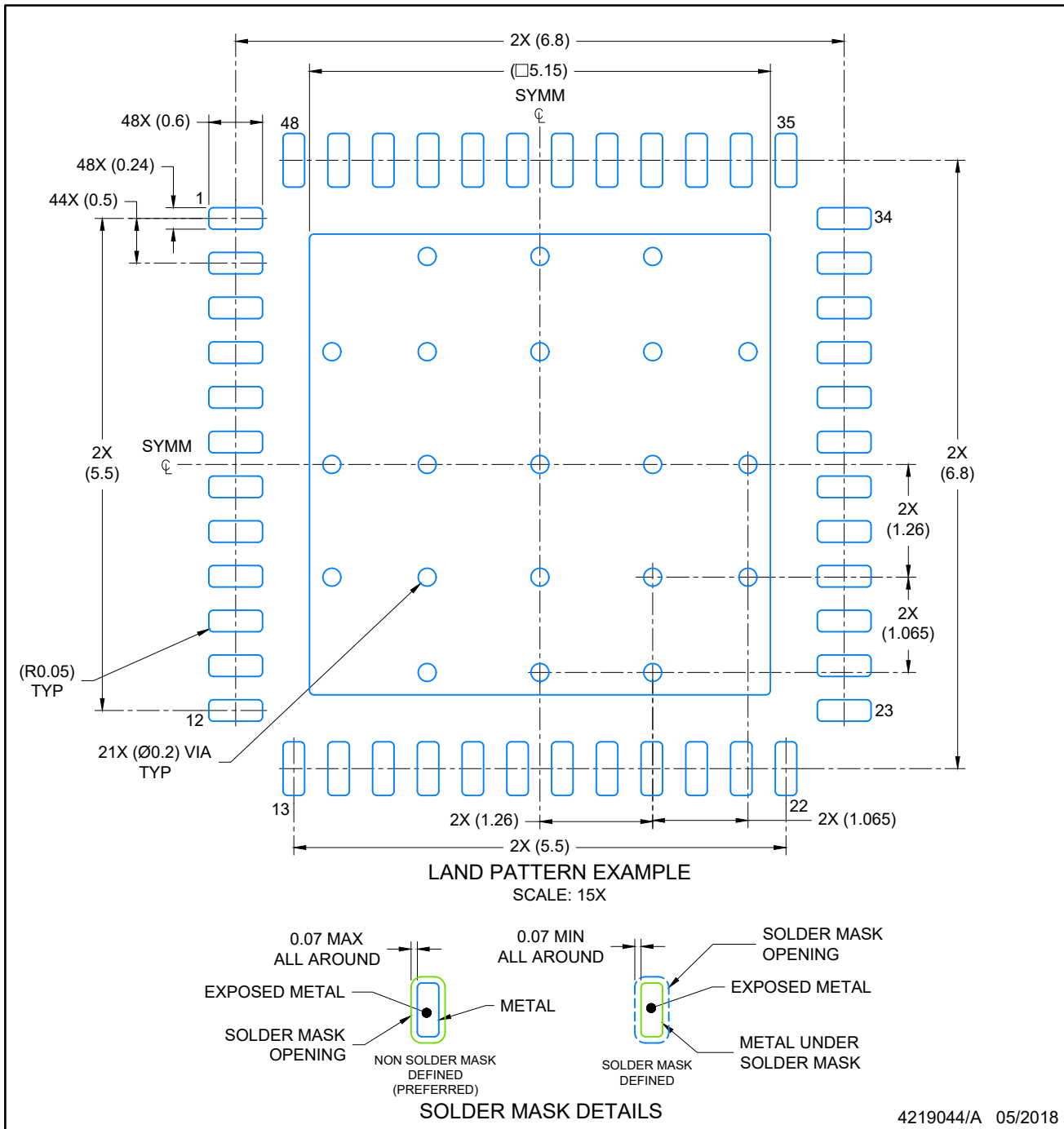

4219044/A 05/2018

NOTES: (continued)

4. This package is designed to be soldered to a thermal pad on the board. For more information, see Texas Instruments literature number SLUA271 ([www.ti.com/lit/sluea271](http://www.ti.com/lit/sluea271)).
5. Vias are optional depending on application, refer to device data sheet. If any vias are implemented, refer to their locations shown on this view. It is recommended that vias under paste be filled, plugged or tented.

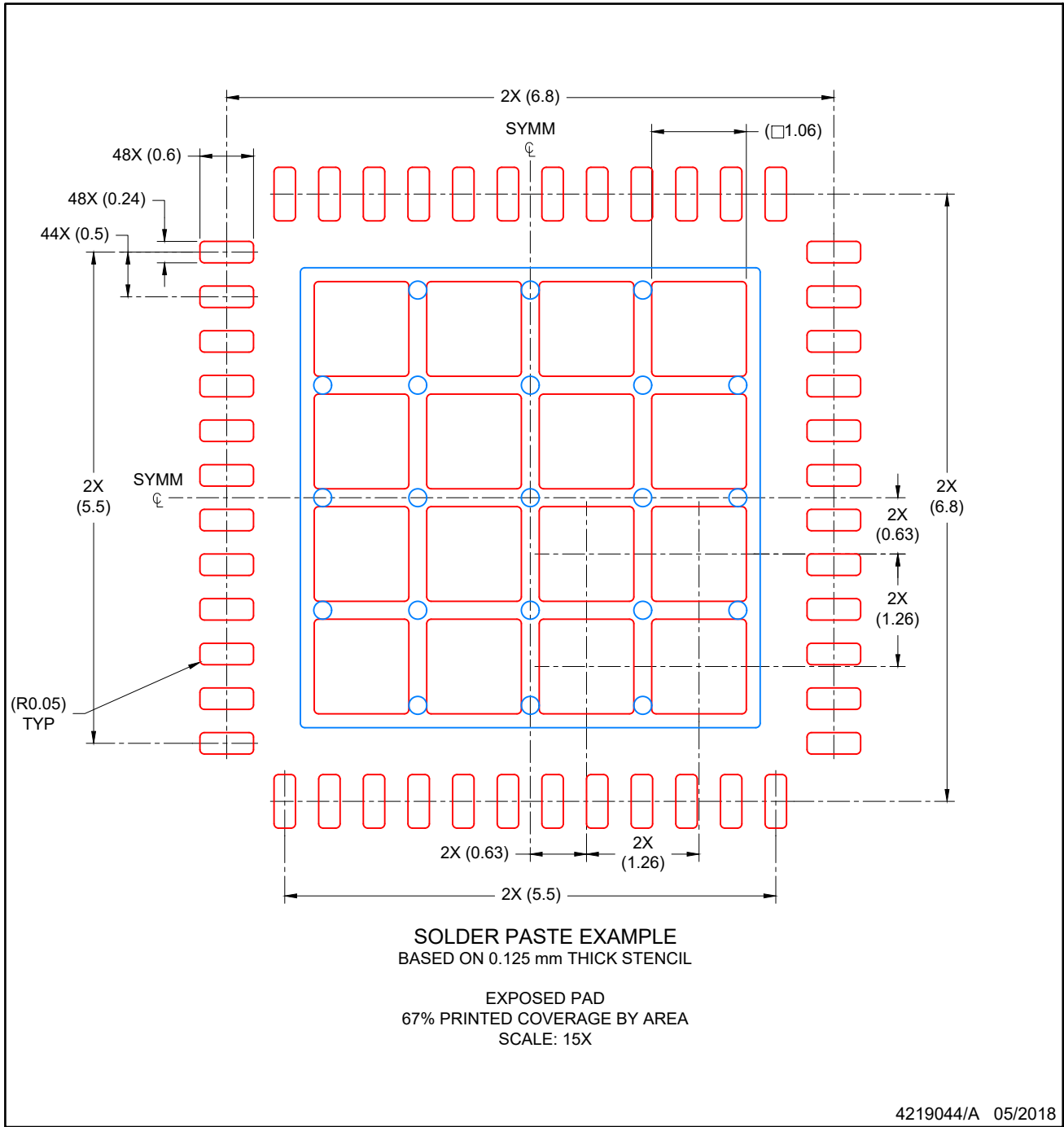

NOTES: (continued)

6. Laser cutting apertures with trapezoidal walls and rounded corners may offer better paste release. IPC-7525 may have alternate design recommendations.

## IMPORTANT NOTICE AND DISCLAIMER

TI PROVIDES TECHNICAL AND RELIABILITY DATA (INCLUDING DATASHEETS), DESIGN RESOURCES (INCLUDING REFERENCE DESIGNS), APPLICATION OR OTHER DESIGN ADVICE, WEB TOOLS, SAFETY INFORMATION, AND OTHER RESOURCES "AS IS" AND WITH ALL FAULTS, AND DISCLAIMS ALL WARRANTIES, EXPRESS AND IMPLIED, INCLUDING WITHOUT LIMITATION ANY IMPLIED WARRANTIES OF MERCHANTABILITY, FITNESS FOR A PARTICULAR PURPOSE OR NON-INFRINGEMENT OF THIRD PARTY INTELLECTUAL PROPERTY RIGHTS.

These resources are intended for skilled developers designing with TI products. You are solely responsible for (1) selecting the appropriate TI products for your application, (2) designing, validating and testing your application, and (3) ensuring your application meets applicable standards, and any other safety, security, or other requirements. These resources are subject to change without notice. TI grants you permission to use these resources only for development of an application that uses the TI products described in the resource. Other reproduction and display of these resources is prohibited. No license is granted to any other TI intellectual property right or to any third party intellectual property right. TI disclaims responsibility for, and you will fully indemnify TI and its representatives against, any claims, damages, costs, losses, and liabilities arising out of your use of these resources.

TI's products are provided subject to TI's Terms of Sale ([www.ti.com/legal/termsofsale.html](http://www.ti.com/legal/termsofsale.html)) or other applicable terms available either on [ti.com](http://ti.com) or provided in conjunction with such TI products. TI's provision of these resources does not expand or otherwise alter TI's applicable warranties or warranty disclaimers for TI products.

Mailing Address: Texas Instruments, Post Office Box 655303, Dallas, Texas 75265  
Copyright © 2018, Texas Instruments Incorporated

## Looking for pricing, stock, or lifecycle information?

Click below to explore more details on WIN SOURCE:

 [View BQ500412RGZT on WIN SOURCE](#)

 [Texas Instruments](#) Information

## Optimize Your Supply Chain with WIN SOURCE Solutions

-  Global Sourcing Solution
-  Obsolete Management
-  Cost Control Management
-  Shortage Management
-  Alternative Solution
-  Excess Inventory Management