



**THE DATASHEET OF
BQ500212ARGZR**



bq500212A Low System Cost, Wireless Power Controller for WPC TX A5 or A11

1 Features

- Proven, Qi-Certified Value Solution for Transmit-Side Application
- Lowest Device Count for Full WPC1.1 5-V Solution
- 5-V Operation Conforms to Wireless Power Consortium (WPC1.1) Type A5 or A11 Transmitter Specification
- Fully WPC Compliant, Including Improved Foreign Object Detection (FOD) Method
- Permits X7R Type Resonant Capacitors for Reduced Cost
- Dynamic Power Limiting™ for USB and Limited Source Operation
- Digital Demodulation Reduces Components
- LED Indication of Charging State and Fault Status
- Low Standby and High Efficiency

2 Applications

- Wireless Power Consortium (WPC1.1) Compliant Wireless Chargers for:
 - Qi-Certified Smart Phones and Other Handhelds
 - Car and Other Vehicle Accessories
- See www.ti.com/wirelesspower for more information on TI's Wireless Charging Solutions

3 Description

The bq500212A is a Qi-certified value solution that integrates all functions required to control wireless power delivery to a single WPC1.1 compliant receiver. It is WPC1.1 compliant and designed for 5-V systems as a wireless power consortium type A5 or A11 transmitter. The bq500212A *pings* the surrounding environment for WPC compliant devices to be powered, safely engages the device, receives packet communication from the powered device and manages the power transfer according to WPC1.1 specification. To maximize flexibility in wireless power control applications, Dynamic Power Limiting (DPL) is featured on the bq500212A. Dynamic Power Limiting enhances user experience by seamlessly optimizing the usage of power available from limited input supplies.

The bq500212A supports both foreign object detection (FOD) and enhanced parasitic metal object detection (PMOD) for legacy product by continuously monitoring the efficiency of the established power transfer, protecting from power loss due to metal objects misplaced in the wireless power transfer field. The bq500212A handles any abnormal condition development during power transfer and provides indicator outputs. Comprehensive status and fault monitoring features enable a low cost yet robust, Qi-certified wireless power system design.

The bq500212A is available in a 48-pin, 7-mm x 7-mm VQFN package.

Device Information⁽¹⁾

PART NUMBER	PACKAGE	BODY SIZE (NOM)
bq500212A	VQFN (48)	7.00 mm x 7.00 mm

(1) For all available packages, see the orderable addendum at the end of the data sheet.

System Diagram

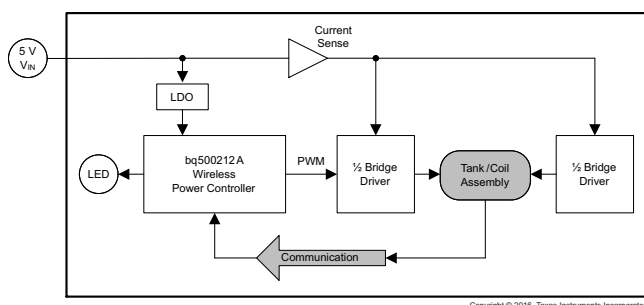

Efficiency vs System Output Power

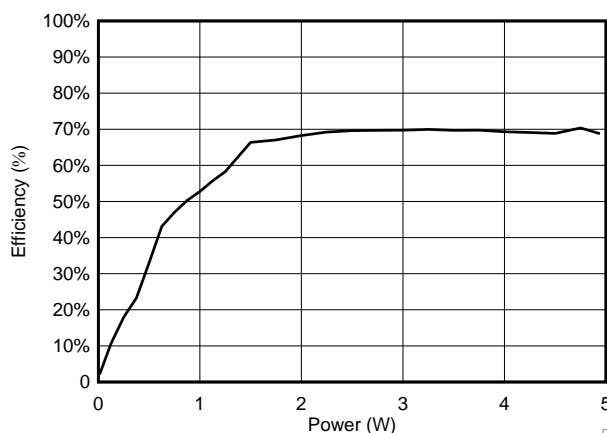

D002



Table of Contents

1 Features 1 2 Applications 1 3 Description 1 4 Revision History 2 5 Pin Configuration and Functions 3 6 Specifications 5 6.1 Absolute Maximum Ratings 5 6.2 ESD Ratings..... 5 6.3 Recommended Operating Conditions..... 5 6.4 Thermal Information 5 6.5 Electrical Characteristics..... 6 6.6 Typical Characteristics 7 7 Detailed Description 8 7.1 Overview 8 7.2 Functional Block Diagram 8 7.3 Feature Description..... 9 7.4 Device Functional Modes..... 12	7.5 Programming..... 14 8 Application and Implementation 15 8.1 Application Information..... 15 8.2 Typical Application 15 9 Power Supply Recommendations 18 10 Layout 18 10.1 Layout Guidelines 18 10.2 Layout Example 19 11 Device and Documentation Support 21 11.1 Device Support..... 21 11.2 Documentation Support 21 11.3 Receiving Notification of Documentation Updates 21 11.4 Community Resources..... 21 11.5 Trademarks 21 11.6 Electrostatic Discharge Caution..... 21 11.7 Glossary 21 12 Mechanical, Packaging, and Orderable Information 21
--	---

4 Revision History

NOTE: Page numbers for previous revisions may differ from page numbers in the current version.

Changes from Revision C (January 2014) to Revision D	Page
<ul style="list-style-type: none"> • Added <i>ESD Ratings</i> table, <i>Feature Description</i> section, <i>Device Functional Modes</i>, <i>Application and Implementation</i> section, <i>Power Supply Recommendations</i> section, <i>Layout</i> section, <i>Device and Documentation Support</i> section, and <i>Mechanical, Packaging, and Orderable Information</i> section 1 • Deleted <i>Ordering Information</i> table; see POA at the end of the data sheet..... 1 	1
Changes from Revision B (November 2013) to Revision C	Page
<ul style="list-style-type: none"> • Changed bq50012A Schematic to bq50012A Block Diagram..... 15 	15
Changes from Revision A (August 2013) to Revision B	Page
<ul style="list-style-type: none"> • Changed WPC1 to WPC1.1 throughout the document. 1 	1
Changes from Original (July) to Revision A	Page
<ul style="list-style-type: none"> • Changed marketing status from Product Preview to Production Data. 1 	1

5 Pin Configuration and Functions

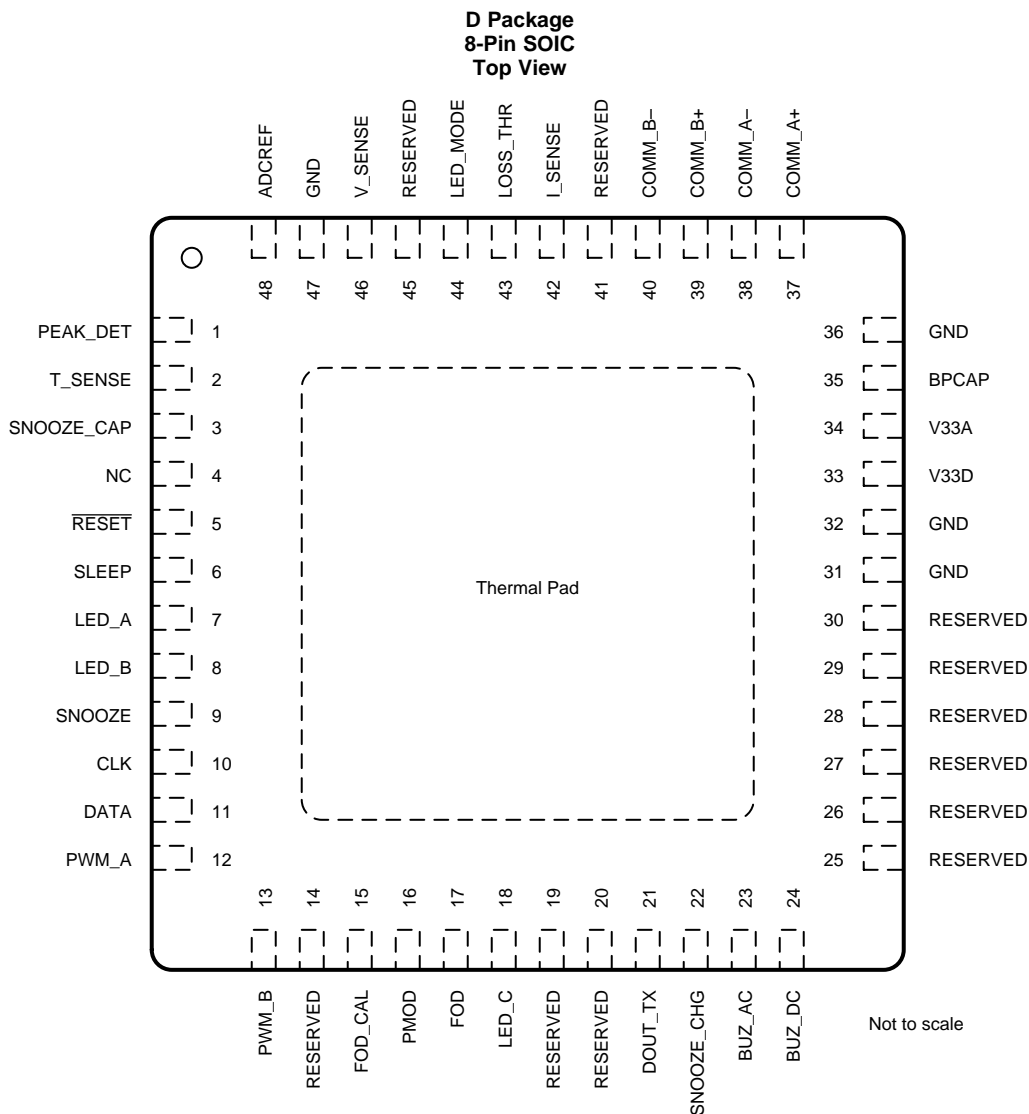

Pin Functions

PIN		TYPE	DESCRIPTION
NAME	NO.		
ADCREG	48	I	External reference voltage input. Connect this input to GND.
BPCAP	35	—	Bypass capacitor for internal 1.8-V core regulator. Connect bypass capacitor to GND.
BUZ_AC	23	O	AC buzzer output. Outputs a 400-ms, 4-kHz AC pulse when charging begins.
BUZ_DC	24	O	DC buzzer output. Outputs a 400-ms DC pulse when charging begins. This could also be connected to an LED through 470-Ω resistor.
CLK	10	I/O	10-kΩ pullup resistor to 3.3-V supply. For factory use only.
COMM_A-	38	I	Digital demodulation inverting input A, connect parallel to input B-.
COMM_A+	37	I	Digital demodulation non-inverting input A, connect parallel to input B+.
COMM_B-	40	I	Digital demodulation inverting input B, connect parallel to input A-.
COMM_B+	39	I	Digital demodulation non-inverting input B, connect parallel to input A+.
DATA	11	I/O	10-kΩ pullup resistor to 3.3-V supply. For factory use only.
DOUT_TX	21	I	Not used. Leave this pin open.

Pin Functions (continued)

PIN		TYPE	DESCRIPTION
NAME	NO.		
EPAD	Thermal Pad	—	Flood with copper GND plane and stitch vias to PCB internal GND plane.
FOD	17	O	Set the threshold used to detect an FOD condition by connecting, through resistor, to LOSS_THR. Leave open to disable FOD.
FOD_CAL	15	O	FOD calibration pin. It controls the FOD calibration setting at start-up.
GND	31	I/O	Reserved, connect to GND.
	32, 36, 47	—	Ground
I_SENSE	42	I	Transmitter input current, used for efficiency calculations. Use 20-mΩ sense resistor and a 50-gain current sense amplifier.
LED_A	7	O	Connect to an LED through 470-Ω resistor for status indication.
LED_B	8	O	Connect to an LED through 470-Ω resistor for status indication.
LED_C	18	O	Connect to an LED through 470-Ω resistor for status indication.
LED_MODE	44	I	Input to select from four LED modes.
LOSS_THR	43	I	Input to program FOD and PMOD thresholds and FOD_CAL correction.
NC	4	—	Not used. Can be left open. Can also be tied to GND and flooded with copper to improve GND plane.
PEAK_DET	1	I	Connected to peak detect circuit. Protects from coil overvoltage event.
PMOD	16	O	Set the threshold used to detect a PMOD condition by connecting, through resistor, to LOSS_THR. Leave open to disable PMOD.
PWM_A	12	O	PWM output A, controls one half of the full bridge in a phase-shifted full bridge. Switching deadtimes must be externally generated.
PWM_B	13	O	PWM output B, controls other half of the full bridge in a phase-shifted full bridge. Switching deadtimes must be externally generated.
RESERVED	14, 19, 41	O	Reserved, leave this pin open.
	25, 26	I/O	Not used, leave this pin open.
	27, 28, 29, 30	I/O	Reserved, leave this pin open.
	20	I	Reserved, connect to GND.
	45	I	Connect to V33D (3.3 V).
RESET	5	I	Device reset. Use a 10-kΩ to 100-kΩ pullup resistor to the 3.3-V supply.
SLEEP	6	O	Connected to 5 s interval circuit.
SNOOZE	9	O	Connected to 500 ms ping interval circuit.
SNOOZE_CAP	3	I	Connected to interval timing capacitor.
SNOOZE_CHG	22	I	Connected to interval timing capacitor.
T_SENSE	2	I	Sensor Input. Device shuts down when below 1 V for longer than 150 ms. If not used, keep above 1 V by connecting to the 3.3-V supply.
V33A	34	—	Analog 3.3-V Supply. This pin can be derived from V33D supply, decouple with 10-Ω resistor and additional bypass capacitors.
V33D	33	—	Digital core 3.3-V supply. Be sure to decouple with bypass capacitors as close to the part as possible.
V_SENSE	46	I	Transmitter input voltage, used for efficiency calculations. Use 76.8-kΩ to 10-kΩ divider to minimize quiescent current.

6 Specifications

6.1 Absolute Maximum Ratings

over operating free-air temperature range (unless otherwise noted)⁽¹⁾

	MIN	MAX	UNIT
Voltage applied at V33D to GND	−0.3	3.6	V
Voltage applied at V33A to GND	−0.3	3.6	
Voltage applied to any pin ⁽²⁾	−0.3	3.6	
Storage temperature, T _{stg}	−40	150	°C

- (1) Stresses beyond those listed under *Absolute Maximum Ratings* may cause permanent damage to the device. These are stress ratings only, which do not imply functional operation of the device at these or any other conditions beyond those indicated under *Recommended Operating Conditions*. Exposure to absolute-maximum-rated conditions for extended periods may affect device reliability.
- (2) All voltages referenced to GND.

6.2 ESD Ratings

		VALUE	UNIT
V _(ESD)	Electrostatic discharge	Human-body model (HBM), per ANSI/ESDA/JEDEC JS-001 ⁽¹⁾	±2000
		Charged-device model (CDM), per JEDEC specification JESD22-C101 ⁽²⁾	±750

- (1) JEDEC document JEP155 states that 500-V HBM allows safe manufacturing with a standard ESD control process.
- (2) JEDEC document JEP157 states that 250-V CDM allows safe manufacturing with a standard ESD control process.

6.3 Recommended Operating Conditions

over operating free-air temperature range (unless otherwise noted)

			MIN	NOM	MAX	UNIT
V	Supply voltage during operation	V33D, V33A	3	3.3	3.6	V
T _A	Operating free-air temperature		−40		110	°C
T _J	Junction temperature				110	°C

6.4 Thermal Information

THERMAL METRIC ⁽¹⁾		bq500212A	UNIT
		RGZ (VQFN)	
		48 PINS	
R _{θJA}	Junction-to-ambient thermal resistance	28.4	°C/W
R _{θJC(top)}	Junction-to-case (top) thermal resistance	14.2	°C/W
R _{θJB}	Junction-to-board thermal resistance	5.4	°C/W
ψ _{JT}	Junction-to-top characterization parameter	0.2	°C/W
ψ _{JB}	Junction-to-board characterization parameter	5.3	°C/W
R _{θJC(bot)}	Junction-to-case (bottom) thermal resistance	1.4	°C/W

- (1) For more information about traditional and new thermal metrics, see the *Semiconductor and IC Package Thermal Metrics* application report.

6.5 Electrical Characteristics

over operating free-air temperature range (unless otherwise noted)

PARAMETER		TEST CONDITIONS	MIN	TYP	MAX	UNIT
SUPPLY CURRENT						
I_{V33A}	Supply current	V33A = 3.3 V		8	15	mA
I_{V33D}		V33D = 3.3 V		44	55	
I_{TOTAL}		V33D = V33A = 3.3 V		52	60	
INTERNAL REGULATOR CONTROLLER INPUTS AND OUTPUTS						
V33	3.3-V linear regulator	Emitter of NPN transistor	3.25	3.3	3.6	V
V33FB	3.3-V linear regulator feedback			4	4.6	
I_{V33FB}	Series pass base drive	$V_{IN} = 12$ V; current into V33FB pin		10		mA
Beta	Series NPN pass device		40			
EXTERNALLY SUPPLIED 3.3 V POWER						
V33D	Digital 3.3-V power	$T_A = 25^\circ\text{C}$	3		3.6	V
V33A	Analog 3.3-V power	$T_A = 25^\circ\text{C}$	3		3.6	
V33Slew	V33 slew rate	V33 slew rate between 2.3 V to 2.9 V, V33A = V33D	0.25			V/ms
DIGITAL DEMODULATION INPUTS COMM_A+, COMM_A-, COMM_B+, COMM_B-						
V_{bias}	COMM+ bias voltage			1.5		V
COMM+, COMM-	Modulation voltage digital resolution			1		mV
R_{EA}	Input impedance	Ground reference	0.5	1.5	3	M Ω
I_{OFFSET}	Input offset current	1-k Ω source impedance	-5		5	μA
ANALOG INPUTS V_SENSE, I_SENSE, T_SENSE, LED_MODE, LOSS_THR, SNOOZE_CAP, PWR_UP						
V_{ADDR_OPEN}	Voltage indicating open pin	LED_MODE open	2.37			V
V_{ADDR_SHORT}	Voltage indicating pin shorted to GND	LED_MODE shorted to ground			0.36	
V_{ADC_RANGE}	Measurement range for voltage monitoring	All analog inputs	0		2.5	
INL	ADC integral nonlinearity		-2.5		2.5	mV
R_{IN}	Input impedance	Ground reference	8			M Ω
C_{IN}	Input capacitance				10	pF
DIGITAL INPUTS/OUTPUTS						
V_{OL}	Low-level output voltage	$I_{OL} = 6$ mA, V33D = 3 V			DGND1 + 0.25	V
V_{OH}	High-level output voltage	$I_{OH} = -6$ mA, V33D = 3 V	V33D - 0.6 V			
V_{IH}	High-level input voltage	V33D = 3 V	2.1		3.6	
V_{IL}	Low-level input voltage	V33D = 3.5 V			1.4	
$I_{OH(MAX)}$	Output high source current				4	mA
$I_{OL(MAX)}$	Output low sink current				4	
SYSTEM PERFORMANCE						
V_{RESET}	Voltage where device comes out of reset	V33D pin			2.4	V
t_{RESET}	Pulse width needed for reset	RESET pin	2			μs
f_{SW}	Switching Frequency		112		205	kHz

6.6 Typical Characteristics

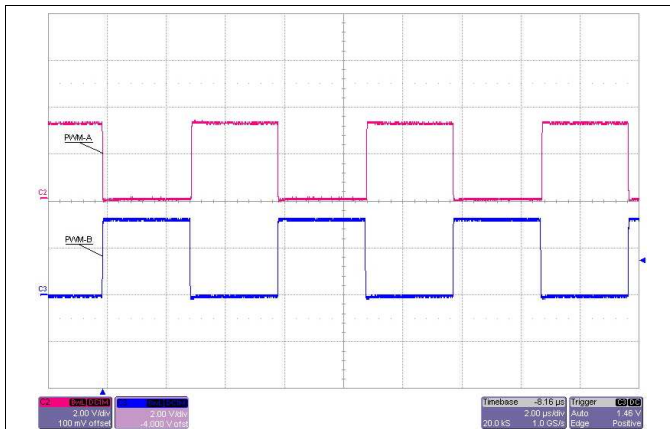

Figure 1. Typical PWM-A and PWM-B Signals

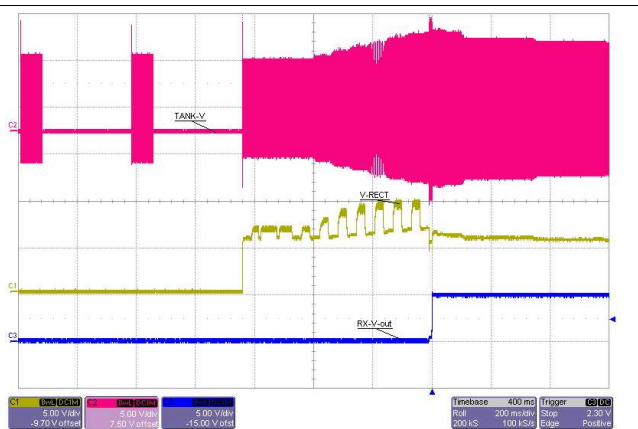

Figure 2. Typical Start-Up With RX

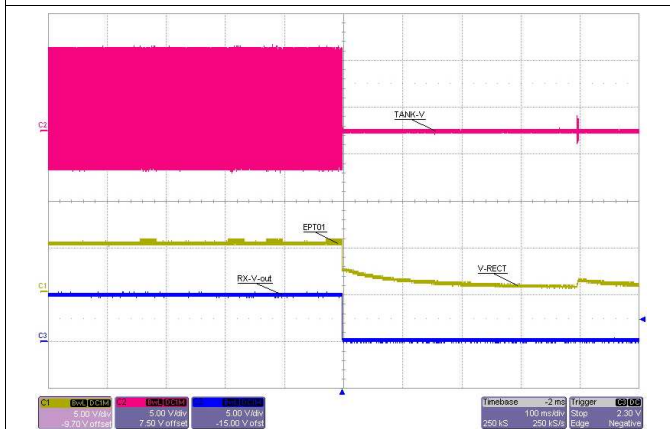

Figure 3. Typical Shutdown EPT01

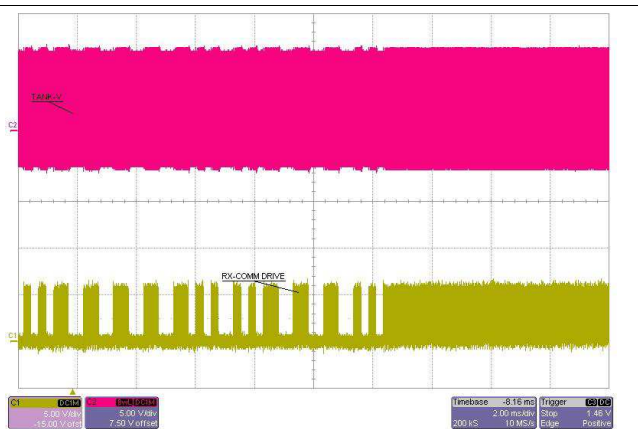

Figure 4. Typical Comm RX to TX

7 Detailed Description

7.1 Overview

The principle of wireless power transfer is simply an open-cored transformer consisting of transmitter and receiver coils. The transmitter coil and electronics are typically built into a charger pad, and the receiver coil and electronics are typically built into a portable device such as a cell phone. When the receiver coil is positioned on the transmitter coil, magnetic coupling can occur when the transmitter coil is driven. The flux is coupled into the secondary coil, inducing a voltage, causing current to flow. The secondary voltage is rectified, allowing power to be transferred effectively to a load wirelessly. Power transfer can be managed through any of the various closed-loop control schemes.

7.2 Functional Block Diagram

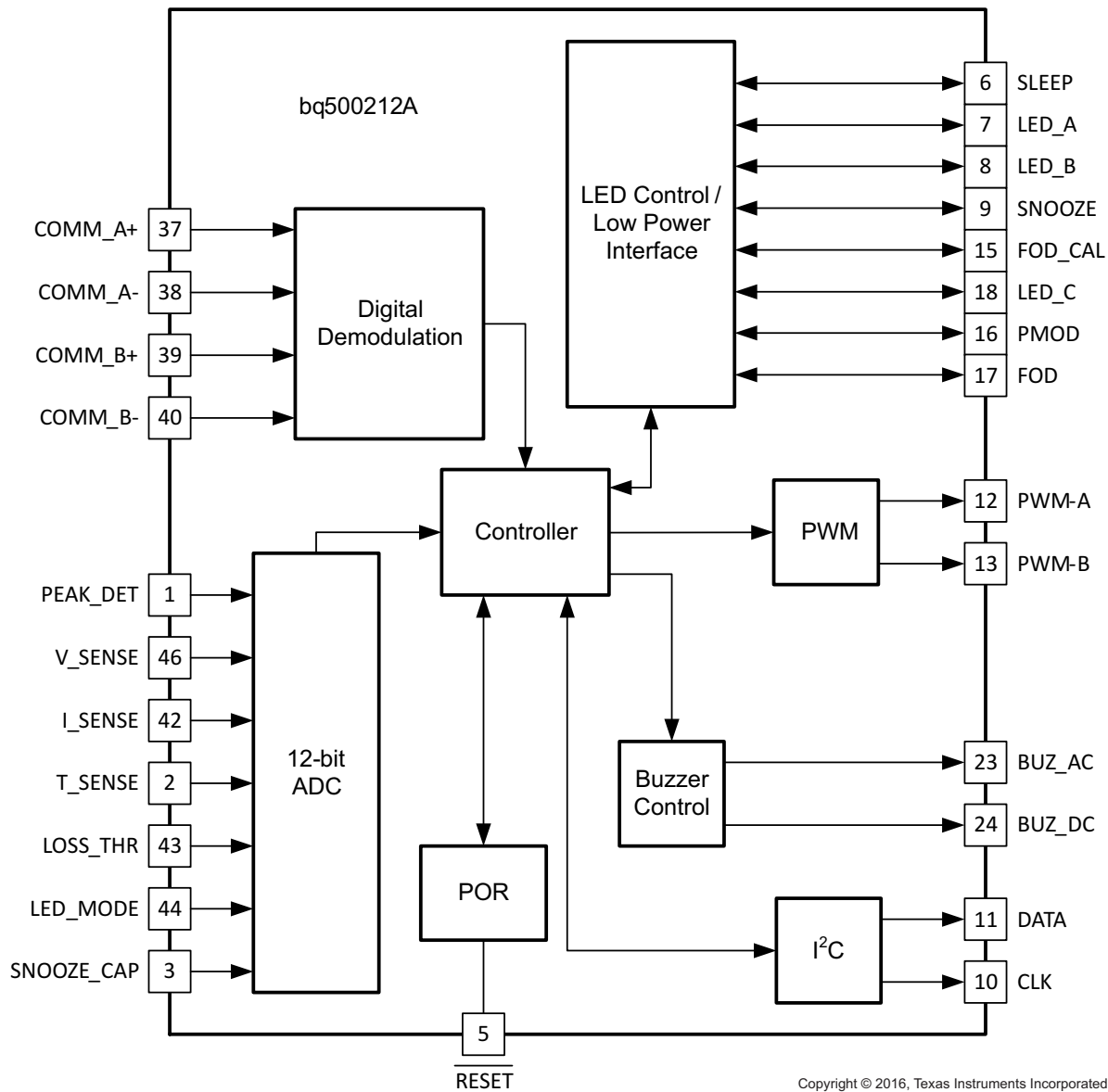

Copyright © 2016, Texas Instruments Incorporated

7.3 Feature Description

7.3.1 Principles of Operation

7.3.1.1 Fundamentals

The principle of wireless power transfer is simply an open-cored transformer consisting of primary and secondary coils and associated electronics. The primary coil and electronics are also referred to as the transmitter, and the secondary side the receiver. The transmitter coil and electronics are typically built into a charger pad. The receiver coil and electronics are typically built into a portable device, such as a cell phone.

When the receiver coil is positioned on the transmitter coil, magnetic coupling occurs when the transmitter coil is driven. The flux is coupled into the secondary coil which induces a voltage, current flows, it is rectified and power can be transferred quite effectively to a load wirelessly. Power transfer can be managed through any of various familiar closed-loop control schemes.

7.3.1.2 Wireless Power Consortium (WPC)

The Wireless Power Consortium (WPC) is an international group of companies from diverse industries. The WPC standard was developed to facilitate cross compatibility of compliant transmitters and receivers. The standard defines the physical parameters and the communication protocol to be used in wireless power. For more information, go to www.wirelesspowerconsortium.com.

7.3.1.3 Power Transfer

Power transfer depends on coil coupling. Coupling is dependant on the distance between coils, alignment, coil dimensions, coil materials, number of turns, magnetic shielding, impedance matching, frequency, and duty cycle.

Most importantly, the receiver and transmitter coils must be aligned for best coupling and efficient power transfer. The closer the space between the coils, the better the coupling, but the practical distance is set to be less than 5 mm (as defined within the WPC Specification) to account for housing and interface surfaces.

Shielding is added as a backing to both the transmitter and receiver coils to direct the magnetic field to the coupled zone. Magnetic fields outside the coupled zone do not transfer power. Thus, shielding also serves to contain the fields to avoid coupling to other adjacent system components.

Regulation can be achieved by controlling any one of the coil coupling parameters. For WPC compatibility, the transmitter coils and capacitance are specified and the resonant frequency point is fixed at 100 kHz. Power transfer is regulated by changing the operating frequency between 110 kHz to 205 kHz. The higher the frequency, the further from resonance and the lower the power. Duty cycle remains constant at 50% throughout the power band and is reduced only once 205 kHz is reached.

The WPC standard describes the dimension and materials of the coils. It also has information on tuning the coils to resonance. The value of the inductor and resonant capacitor are critical to proper operation and system efficiency.

7.3.1.4 Communication

Communication within the WPC is from the receiver to the transmitter, where the receiver tells the transmitter to send power and how much. In order to regulate, the receiver must communicate with the transmitter whether to increase or decrease frequency. The receiver monitors the rectifier output and using Amplitude Modulation (AM), sends packets of information to the transmitter. A packet is comprised of a preamble, a header, the actual message and a checksum, as defined by the WPC standard.

The receiver sends a packet by modulating an impedance network. This AM signal reflects back as a change in the voltage amplitude on the transmitter coil. The signal is demodulated and decoded by the transmitter side electronics and the frequency of its coil drive output is adjusted to close the regulation loop. The bq500212A device features internal digital demodulation circuitry.

The modulated impedance network on the receiver can either be resistive or capacitive. [Figure 5](#) shows the resistive modulation approach, where a resistor is periodically added to the load and also shows the resulting change in resonant curve which causes the amplitude change in the transmitter voltage indicated by the two operating points at the same frequency. [Figure 6](#) shows the capacitive modulation approach, where a capacitor is periodically added to the load and also shows the resulting amplitude change in the transmitter voltage.

Feature Description (continued)

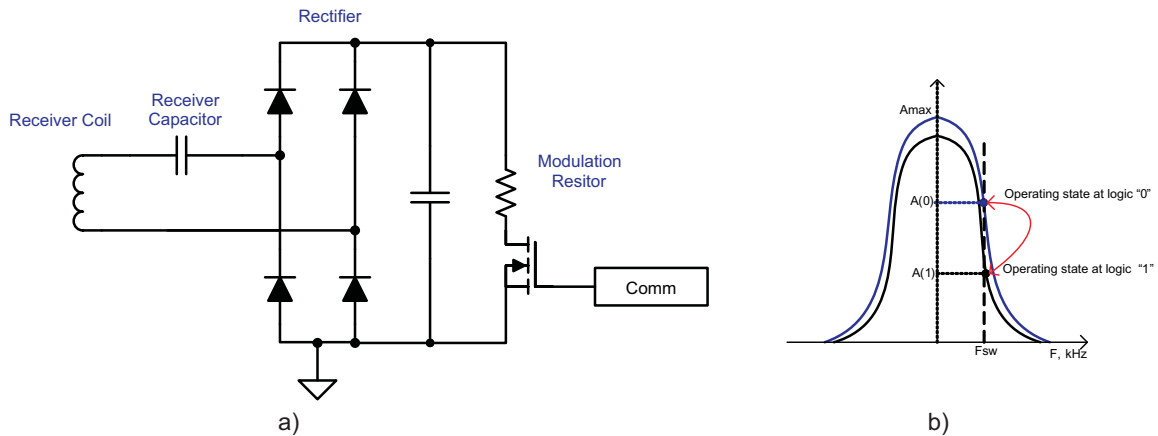

Figure 5. Receiver Resistive Modulation Circuit

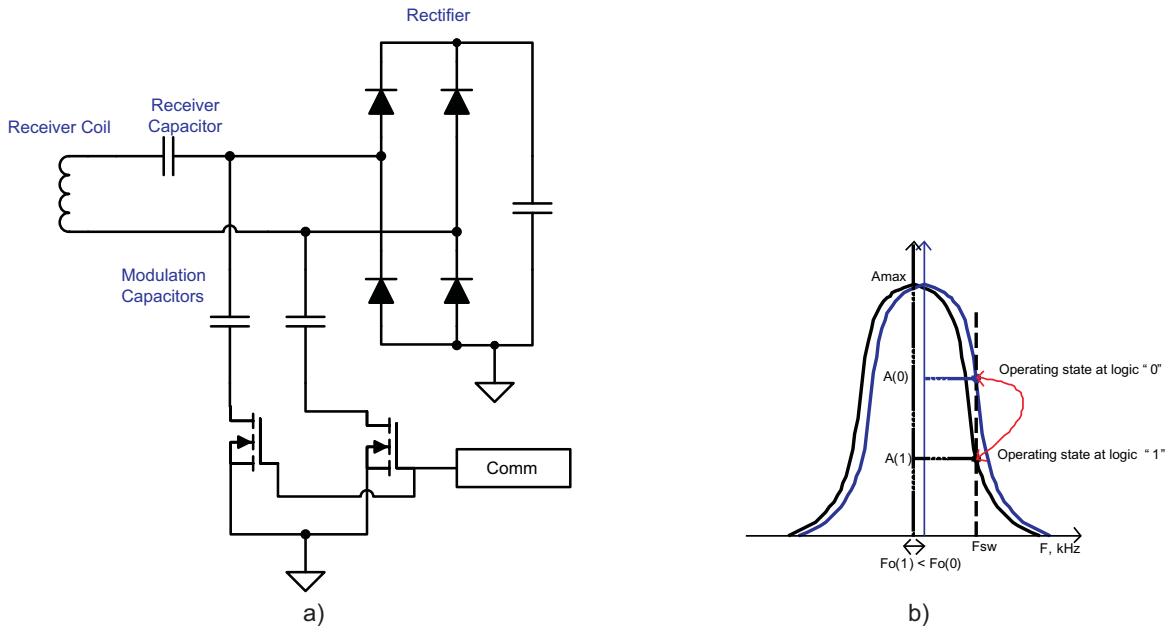

Figure 6. Receiver Capacitive Modulation Circuit

7.3.2 Dynamic Power Limiting

Dynamic Power Limiting (DPL) allows operation from a 5-V supply with limited current capability (such as a USB port). When the input voltage is observed drooping, the output power is dynamically limited to reduce the load and provides margin relative to the supply's capability.

Anytime the DPL control loop is regulating the operating point of the transmitter, the LED indicates that DPL is active. The LED color and flashing pattern are determined by the [Table 2](#). If the receiver sends a Control Error Packet (CEP) with a negative value, (for example, to reduce power to the load), the WPTX in DPL mode responds to this CEP through the normal WPC control loop.

NOTE

The power limit indication depends on the LED_MODE selected.

Feature Description (continued)

7.3.3 Shut Down Through External Thermal Sensor or Trigger

Typical applications of the bq500212A device do not require additional thermal protection. This shutdown feature is provided for enhanced applications and is not only limited to thermal shutdown. The key parameter is the 1-V threshold on T_SENSE pin. Voltage below 1 V on T_SENSE pin for longer than 150 ms causes the device to shutdown.

The application of thermal monitoring through a Negative Temperature Coefficient (NTC) sensor, for example, is straightforward. The NTC forms the lower leg of a temperature dependant voltage divider. The NTC leads are connected to the bq500212A device, T_SENSE pin and GND. The threshold on T_SENSE pin is set to 1 V, below which the system shuts down and a fault is indicated (depending on LED mode chosen).

To implement this feature follow these steps:

1. Consult the NTC data sheet and find the resistance vs temperature curve.
2. Determine the actual temperature where the NTC is placed by using a thermal probe.
3. Read the NTC resistance at that temperature in the NTC data sheet, that is R_NTC.
4. Use Equation 1 to determine the upper leg resistor (R_Setpoint):

$$R_Setpoint = 2.3 \times R_NTC \tag{1}$$

The system restores normal operation after approximately five minutes or if the receiver is removed. If the feature is not used, this pin must be pulled high.

NOTE

T_SENSE pin must always be terminated; otherwise, erratic behavior may result.

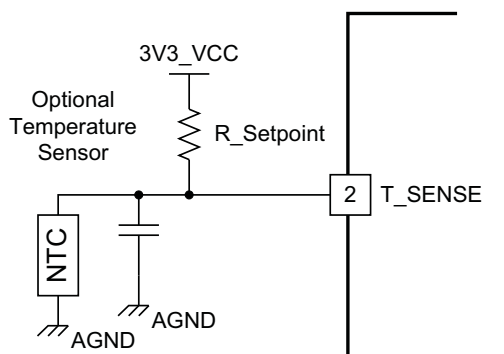

Figure 7. Negative Temperature Coefficient (NTC) Application

7.3.4 Fault Handling and Indication

Table 1 provides approximate durations for the time before a retry is attempted for end power transfer (EPT) packets and fault events. Precise timing may be affected by external components, or shortened by receiver removal. The LED mode selected determines how the LED indicates the condition or fault.

Table 1. Fault Handling

CONDITION	DURATION (BEFORE RETRY)	HANDLING
EPT-00	Immediate	Unknown
EPT-01	5 s	Charge complete
EPT-02	Infinite	Internal fault
EPT-03	5 minutes	Over temperature
EPT-04	Immediate	Over voltage
EPT-05	Immediate	Over current
EPT-06	Infinite	Battery failure

Table 1. Fault Handling (continued)

CONDITION	DURATION (BEFORE RETRY)	HANDLING
EPT-07	Not applicable	Reconfiguration
EPT-08	Immediate	No response
OC (over current)	1 minute	
NTC (external sensor)	5 minutes	
PMOD/FOD warning	12 s	10 s LED only, 2 s LED + buzzer
PMOD/FOD	5 minutes	

7.3.5 Power Transfer Start Signal

The bq500212A device features two signal outputs to indicate that power transfer has begun. BUZ_AC pin outputs a 400-ms duration, 4-kHz square wave for driving low-cost, AC-type ceramic buzzers. BUZ_DC pin outputs logic high, also for 400 ms, which is suitable for DC type buzzers with built-in tone generators, or as a trigger for any type of customized indication scheme. If not used, these pins can be left open.

7.3.6 Power On Reset

The bq500212A device has an integrated Power On Reset (POR) circuit which monitors the supply voltage and handles the correct device start-up sequence. Additional supply voltage supervisor or reset circuits are not needed.

7.3.7 External Reset, $\overline{\text{RESET}}$ Pin

The bq500212A device can be forced into a reset state by an external circuit connected to the $\overline{\text{RESET}}$ pin. A logic low voltage on this pin holds the device in reset. For normal operation, this pin is pulled up to 3.3 V_{CC} with a 10-k Ω pullup resistor.

7.3.8 Trickle Charge and CS100

The WPC specification provides an End-of-Power Transfer message (EPT-01) to indicate charge complete. Upon receipt of the charge complete message, the bq500212A device changes the LED indication. The exact indication depends on the LED_MODE chosen.

In some battery charging applications there is a benefit to continue the charging process in trickle-charge mode to top off the battery. There are several information packets in the WPC specification related to the levels of battery charge (Charge Status). The bq500212A device uses these commands to enable top-off charging. The bq500212A device changes the LED indication to reflect charge complete when a Charge Status message is 100% received, but unlike the response to an EPT, it does not halt power transfer while the LED is solid green. The mobile device can use a CS100 packet to enable trickle charge mode.

If the reported charge status drops below 90% normal, charging indication is resumed.

7.4 Device Functional Modes

7.4.1 LED Indication Modes

The bq500212A device can directly drive up to three LED outputs (LED_A, LED_B, and LED_C) through a simple current limit resistor (typically 470 Ω), based on the mode selected. The current limit resistors can be individually adjusted to tune or match the brightness of the LEDs. Do not exceed the maximum output current rating of the device. The resistor in [Figure 8](#) connected to LED_MODE and GND selects the desired LED indication scheme in [Table 2](#).

- LED modes permit the use of one to three indicator LED's. Amber in the 2-LED mode is obtained by turning on both the green and red.
- LEDs can be turned on solid or configured to blink either slow (approximately 1.6 s period) or fast (approximately 400 ms period).
- Except in modes 2 and 9, the charge complete state is only maintained for 5 seconds after which it reverts to idle. This permits the processor to sleep in order to reduce standby power consumption. In other modes, external logic, such as a flip-flop, may be implemented to maintain the charge complete indication if desired.

Device Functional Modes (continued)
Table 2. LED Modes

LED CONTROL OPTION	LED SELECTION RESISTOR	DESCRIPTION	LED	OPERATIONAL STATES					
				STANDBY	POWER TRANSFER	CHARGE COMPLETE	FAULT	DYNAMIC POWER LIMITING	FOD Warning
X	< 36.5 kΩ	Reserved, do not use	LED1, green	—	—	—	—	—	—
			LED2, red						
			LED3, amber						
1	42.2 kΩ	Choice number 1	LED1, green	Off	Blink slow	On	Off	Blink slow	Off
			LED2, red	Off	Off	Off	On	Blink slow	Blink fast
			LED3, amber	—	—	—	—	—	—
2	48.7 kΩ	Choice number 2	LED1, green	On	Blink slow	On	Off	Blink slow	Off
			LED2, red	On	Off	Off	On	Blink slow	Blink fast
			LED3, amber	—	—	—	—	—	—
3	56.2 kΩ	Choice number 3	LED1, green	Off	On	Off	Blink fast	On	On
			LED2, red	—	—	—	—	—	—
			LED3, amber	—	—	—	—	—	—
4	64.9 kΩ	Choice number 4	LED1, green	Off	On	Off	Off	Off	Off
			LED2, red	Off	Off	Off	On	Blink slow	Blink fast
			LED3, amber	—	—	—	—	—	—
5	75 kΩ	Choice number 5	LED1, green	Off	Off	On	Off	Off	Off
			LED2, red	Off	On	Off	Off	On	On
			LED3, amber	Off	Off	Off	Blink slow	Off	Off
6	86.6 kΩ	Choice number 6	LED1, green	Off	Blink slow	On	Off	Off	Off
			LED2, red	Off	Off	Off	On	Off	Blink fast
			LED3, amber	Off	Off	Off	Off	Blink Slow	Off
7	100 kΩ	Choice number 7	LED1, green	Off	Blink slow	Off	Off	Off	Off
			LED2, red	Off	Off	On	Off	Off	Off
			LED3, amber	Off	Off	Off	On	Blink slow	Blink fast
8	115 kΩ	Choice number 8	LED1, green	Off	Off	On	Blink slow	Off	Off
			LED2, red	Off	On	Off	Blink slow	On	On
			LED3, amber	—	—	—	—	—	—
9	133 kΩ	Choice number 9	LED1, green	Off	Blink slow	On	Off	Blink slow	Off
			LED2, red	Off	Off	Off	On	Blink slow	Blink fast
			LED3, amber	—	—	—	—	—	—
10	154 kΩ	Choice number 10	LED1, green	Off	On	Off	Blink fast	Blink slow	On
			LED2, red	Off	Off	On	Off	Off	Off
			LED3, amber	—	—	—	—	—	—

7.4.2 Low Power Mode

During standby, when nothing is on the transmitter pad, the bq500212A device pings the surrounding environment at fixed intervals. The ping interval can be adjusted; the component values selected for the SNOOZE circuit determine this interval between pings. The choice of the ping interval effects two quantities: the idle efficiency of the system, and the time required to detect the presence of a receiver when it is placed on the pad. A trade-off must be made which balances low power (longest ping interval) with good user experience (quick detection through short ping interval) while still meeting the WPC requirement for detection within 0.5 seconds.

The system power consumption is approximately 300 mW during an active ping, which lasts approximately 90 ms, and 40 mW for the balance of the cycle. A weighted average can thus be used to estimate the overall system's idle consumption:

If T_{ping} is the interval between pings in ms, P_{idle} in mW is calculated with [Equation 2](#).

$$P_{idle} \text{ (mW)} = (40 \times (T_{ping} - 90) + 300 \times 90) / T_{ping} \quad (2)$$

7.5 Programming

7.5.1 Option Select Pins

Several pins on the bq500212A device are allocated to programming the FOD and PMOD Loss Threshold and the LED mode of the device. At power up, a bias current is applied to pins LED_MODE and LOSS_THR and the resulting voltage measured in order to identify the value of the attached programming resistor. The values of the operating parameters set by these pins are determined using [Table 4](#). For LED_MODE, the selected bin determines the LED behavior based on [Table 2](#); for the LOSS_THR, the selected bin sets a threshold used for PMOD (see [PMOD, FOD, and FOD Calibration](#)). See [Table 2](#).

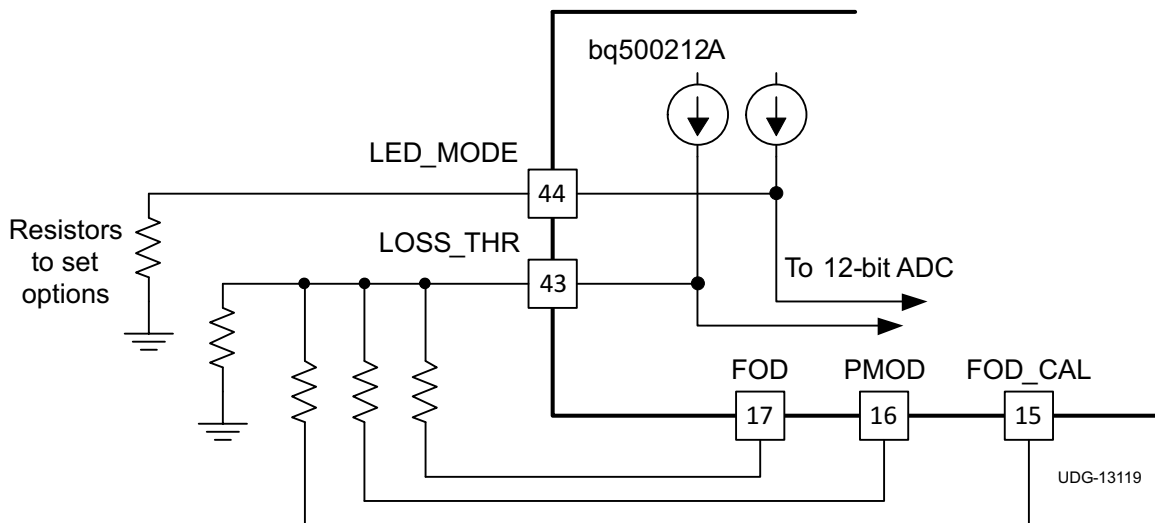

Figure 8. Option Select Pin Programming

7.5.2 Current Monitoring Requirements

The bq500212A device is WPC1.1 ready. To enable the FOD or PMOD features, current monitoring circuitry must be provided in the application design.

For proper scaling of the current monitor signal, the current sense resistor must be 20 mΩ and the current shunt amplifier must have a gain of 50, such as the INA199A1. For FOD accuracy, the current sense resistor must be a quality component with 1% tolerance, at least 1/4-W rating, and a temperature stability of ±200 PPM. Proper current sensing techniques in the application hardware must also be observed.

If WPC compliance is not required current monitoring can be omitted. Connect the I_SENSE pin to GND.

7.5.3 All Unused Pins

All unused pins can be left open unless otherwise indicated. The NC pin can be tied to GND and flooded with copper to improve ground shielding. See [Pin Configuration and Functions](#) for further more information.

8 Application and Implementation

NOTE

Information in the following applications sections is not part of the TI component specification, and TI does not warrant its accuracy or completeness. TI's customers are responsible for determining suitability of components for their purposes. Customers should validate and test their design implementation to confirm system functionality.

8.1 Application Information

The bq500212A device is a wireless power transmitter controller designed for 5-W WPC compliant applications. The device has all features required to support receivers that are compliant with WPC 1.0, 1.1, and Low Power 1.2. Additional tools and application information can be found in the [bq500212A](#) product folder. The following section highlights some of the system design considerations.

8.2 Typical Application

Figure 9 shows the application schematic for the transmitter with reduced standby power.

NOTE

Check the [bq500212A](#) product page for the most up-to-date application schematic and list of materials package before starting a new design.

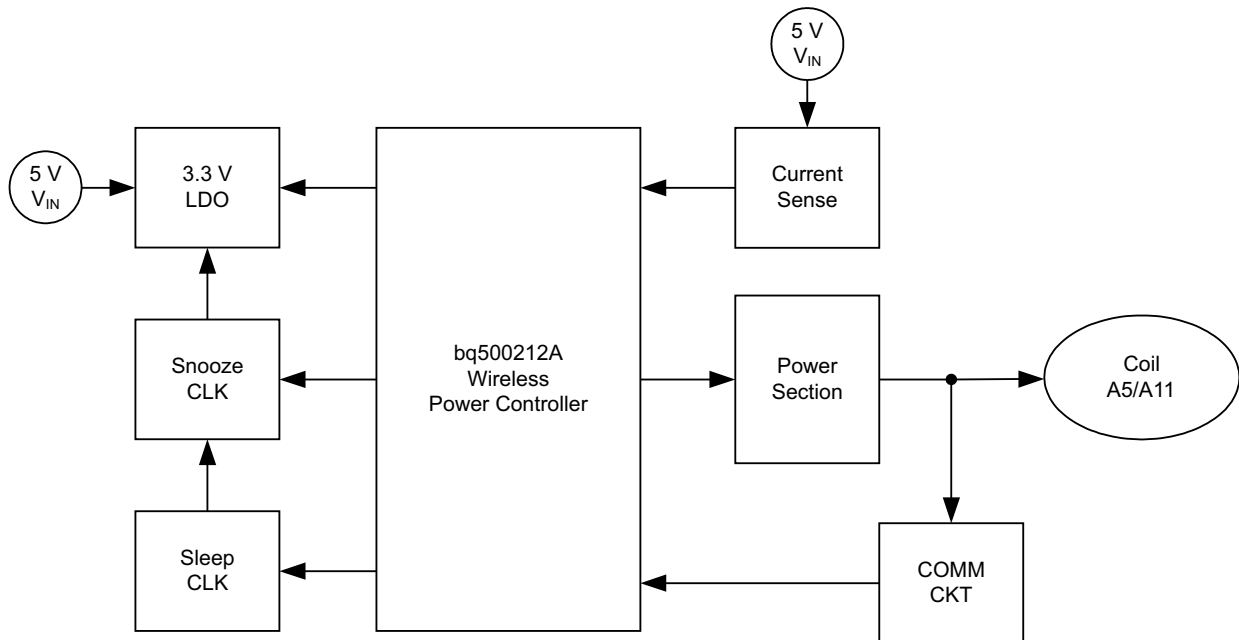

Copyright © 2016, Texas Instruments Incorporated

Figure 9. bq500212A Block Diagram

8.2.1 Design Requirements

For this design example, use the parameters listed in [Table 3](#) as the input parameters.

Table 3. Design Parameters

PARAMETER	EXAMPLE VALUE
WPC coil type	A11 and A5
Input voltage	5 V ±5% (5-V input to A11 / A5 TX)

8.2.2 Detailed Design Procedure

8.2.2.1 PMOD, FOD, and FOD Calibration

The bq500212A device supports improved FOD (WPC1.1) and enhanced PMOD (WPC 1.0) features. Continuously monitoring input power, known losses, and the value of power reported by the RX device being charged, the bq500212A device can estimate how much power is unaccounted for and presumed lost due to metal objects placed in the wireless power transfer path. If this unexpected loss exceeds the threshold set by the FOD or PMOD resistors, a fault is indicated and power transfer is halted. Whether the FOD or the PMOD algorithm is used is determined by the ID packet of the receiver being charged.

As the default, both PMOD and FOD resistors must set a threshold of 400 mW (selected by 56.2-k Ω resistors from FOD and PMOD to LOSS_THR. 400 mW has been empirically determined using standard WPC FOD test objects (disc, ring, and foil). Some tuning might be required as every system is slightly different. This tuning is best done by trial and error, use the set resistor values given in the table to increase or decrease the loss threshold and retry the system with the standard test objects. The ultimate goal of the FOD feature is safety; to protect misplaced metal objects from becoming hot. Reducing the loss threshold and making the system too sensitive leads to false trips and a bad user experience. Find the balance which best suits the application.

If the application requires disabling one function or the other (or both), it is possible by leaving the respective FOD pin and PMOD pin open. For example, to selectively disable the PMOD function, PMOD must be left open.

NOTE

Disabling FOD results in a TX solution that is not WPC compliant.

Resistors of 1% tolerance must be used for a reliable selection of the desired threshold.

The FOD and PMOD resistors program the permitted power loss for the FOD and PMOD algorithms respectively. The FOD_CAL resistor, can be used to compensate for any load dependent effect on the power loss. Using a calibrated test receiver with no foreign objects present, the FOD_CAL resistor must be selected such that the calculated loss across the load range is substantially constant (within approximately 100 mW). After correcting for the load dependence, the FOD and PMOD thresholds must be reset above the resulting average by approximately 400 mW for the transmitter to satisfy the WPC requirements on tolerated heating. Contact TI for more information about setting appropriate FOD, PMOD, and FOD_CAL resistor values for your design.

Table 4. Option Select Bins

BIN NUMBER	RESISTANCE (k Ω)	LOSS THRESHOLD (mW)
0	<36.5	250
1	42.2	300
2	48.7	350
3	56.2	400
4	64.9	450
5	75	500
6	86.6	550
7	100	600
8	115	650
9	133	700
10	154	750
11	178	800
12	205	850
13	>237	Feature Disabled

8.2.2.2 Coils and Matching Capacitors

The coil and matching capacitor selection for the transmitter has been established by WPC standard. These values are fixed and cannot be changed on the transmitter side.

An up to date list of available and compatible A5 or A11 transmitter coils can be found in [bqTESLA Transmitter Coil Vendors](#) (SLUA649):

Capacitor selection is critical to proper system operation. A total capacitance value of 400 nF is required in the resonant tank. A 400-nF capacitor is not a standard value and therefore several must be combined in parallel. TI recommends to use 4 × 100 nF, as these are very commonly available.

NOTE

A total capacitance value of 400 nF/50 V is required in the resonant tank to achieve a 100-kHz resonance frequency.

To achieve the 400-nF total capacitance in the resonant tank, the bq500212A device sensitive demodulation circuitry allows the use of 3 lower cost 100-nF/X7R type capacitors in parallel with one (1) high quality 100-nF/C0G type, thereby reducing system cost from competitive solutions requiring four C0G types.

The capacitors chosen must be rated for 50 V operation. Use quality capacitors from reputable vendors such as KEMET, MURATA or TDK.

8.2.2.3 Design Checklist for WPC1.1 Compliance With the bq500212A

- Coil and capacitor selection matches the A5/A11 specification.
- Total 400-nF resonant capacitor requirement is composed of: (3 × 100nF/X7R) + (1 × 100nF/C0G) types.
- Precision current sense amp used, such as the INA199A1. This is required for accurate FOD operation.
- Current shunt resistor 1% and <200 PPM. This is required for accurate FOD operation.

8.2.2.4 Input Regulator

The bq500212A device requires 3.3 VDC to operate. A buck regulator or a linear regulator can be used to step down from the 5-V system input. Either choice is fully WPC compatible, the decision lies in the user's requirements with respect to cost or efficiency.

For lowest cost, TI recommends the TLV70033 linear regulator.

8.2.2.5 Power Train

The bq500212A device drives a phase-shifted full bridge. This is essentially twin half bridges and the choice of driver devices is quite simple; a pair of CSD97376 Integrated Power Stages are used. Other combinations using discrete driver and MOSFETs can work and system performance with regards to efficiency and EMI emissions vary. Any alternate MOSFETs chosen must be fully saturated at the 5-V system gate drive voltage available and be sure to pay attention whether or not to use gate resistors; some tuning might be required.

8.2.3 Application Curves

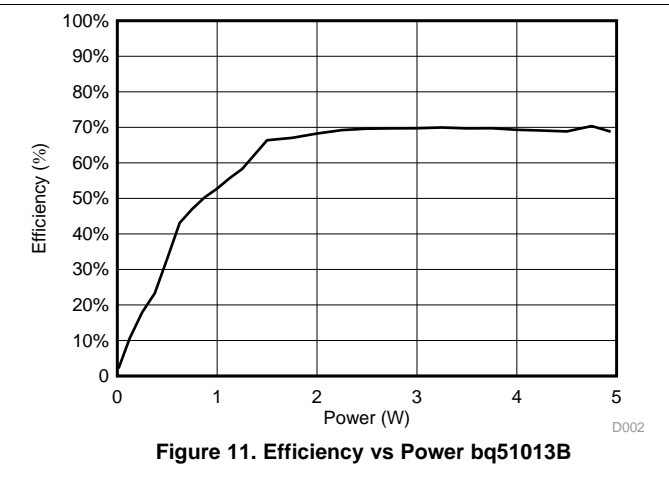
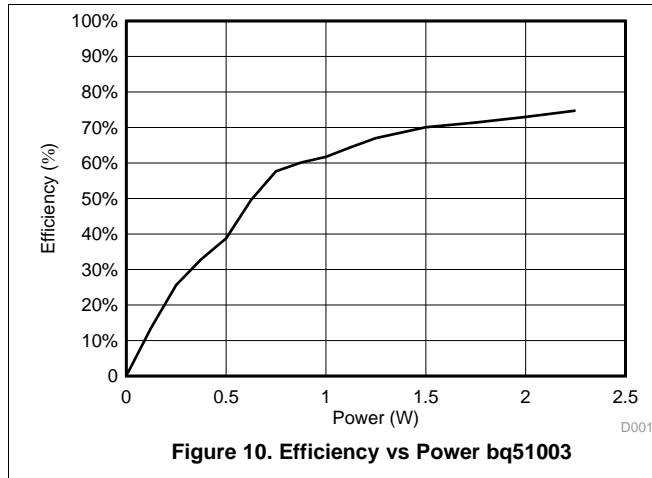

9 Power Supply Recommendations

The bq500212A IC is designed to operate from a well regulated 3.3-V power supply. This can be a low switching power supply or linear regulator. The 3.3-V supply is integrated into a total transmitter solution that is powered from a 5-V supply capable of supporting the output load of 5 W plus conversion losses in the system.

10 Layout

10.1 Layout Guidelines

A good PCB layout is critical to proper system operation. There are many references on proper PCB layout techniques.

Generally speaking, the system layout requires a 4-layer PCB layout, although a 2-layer PCB layout can be achieved. The following list is a proven and recommended approach to the layer stack-up:

- Layer 1, component placement and as much ground plane as possible
- Layer 2, clean ground
- Layer 3, finish routing
- Layer 4, clean ground

Thus, the circuitry is virtually sandwiched between grounds. This minimizes EMI noise emissions and also provides a noise free voltage reference plane for device operation.

Keep as much copper as possible. Make sure the bq500212A GND pins and the power pad have a continuous flood connection to the ground plane. The power pad must also be stitched to the ground plane, which also acts as a heat sink for the bq500212A device. A good GND reference is necessary for proper bq500212A operation, such as analog-digital conversion, clock stability and best overall EMI performance.

Separate the analog ground plane from the power ground plane and use only one tie point to connect grounds. Having several tie points defeats the purpose of separating the grounds.

The COMM return signal from the resonant tank must be routed as a differential pair. This is intended to reduce stray noise induction. The frequencies of concern warrant low-noise analog signaling techniques, such as differential routing and shielding, but the COMM signal lines do not need to be impedance matched.

Typically a single-chip controller solution with integrated power FET and synchronous rectifier is used. To create a tight loop, pull in the buck inductor and power loop as close as possible. Likewise, the power train, full-bridge components must be pulled together as tight as possible. See the [bq500212AEVM-550](#), [bqTESLA Wireless Power TX EVM User's Guide](#) (SLVU536) for layout examples.

Layout Guidelines (continued)

Use a ground flood connection for the ground plane under the device. Connect the device ground pins to the thermal pad. Flow the ground plane between the thermal pad and top layer ground. Use multiple vias to connect the thermal pad to the internal ground layer. Verify that the solder mask under the device is removed for good connection to the thermal pad.

The customer must choose a full-bridge option to design the power section. [Figure 13](#), based on the bq500212A EVM, uses a power stage device, which is an integrated drive and two MOSFETs.

10.2 Layout Example

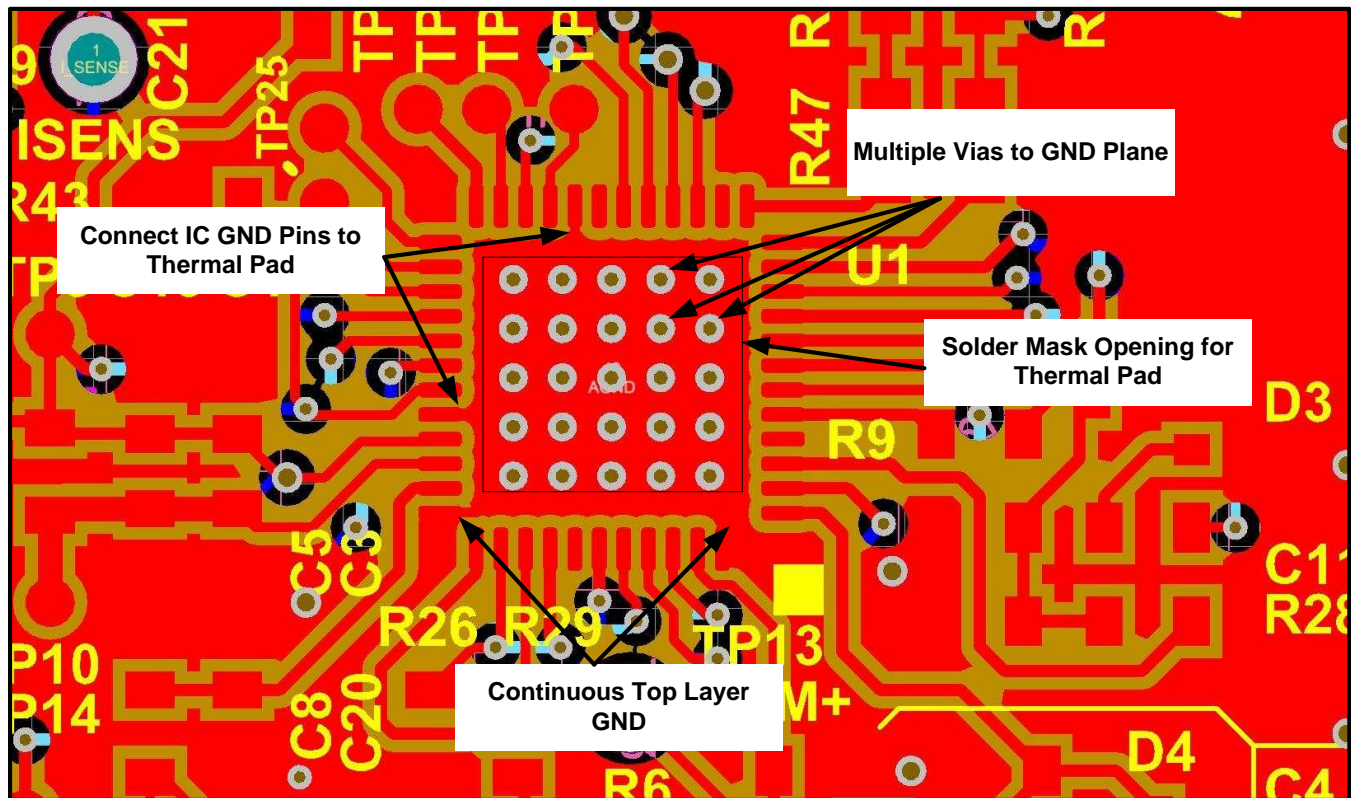

Figure 12. bq500212A IC Ground Connections

Layout Example (continued)

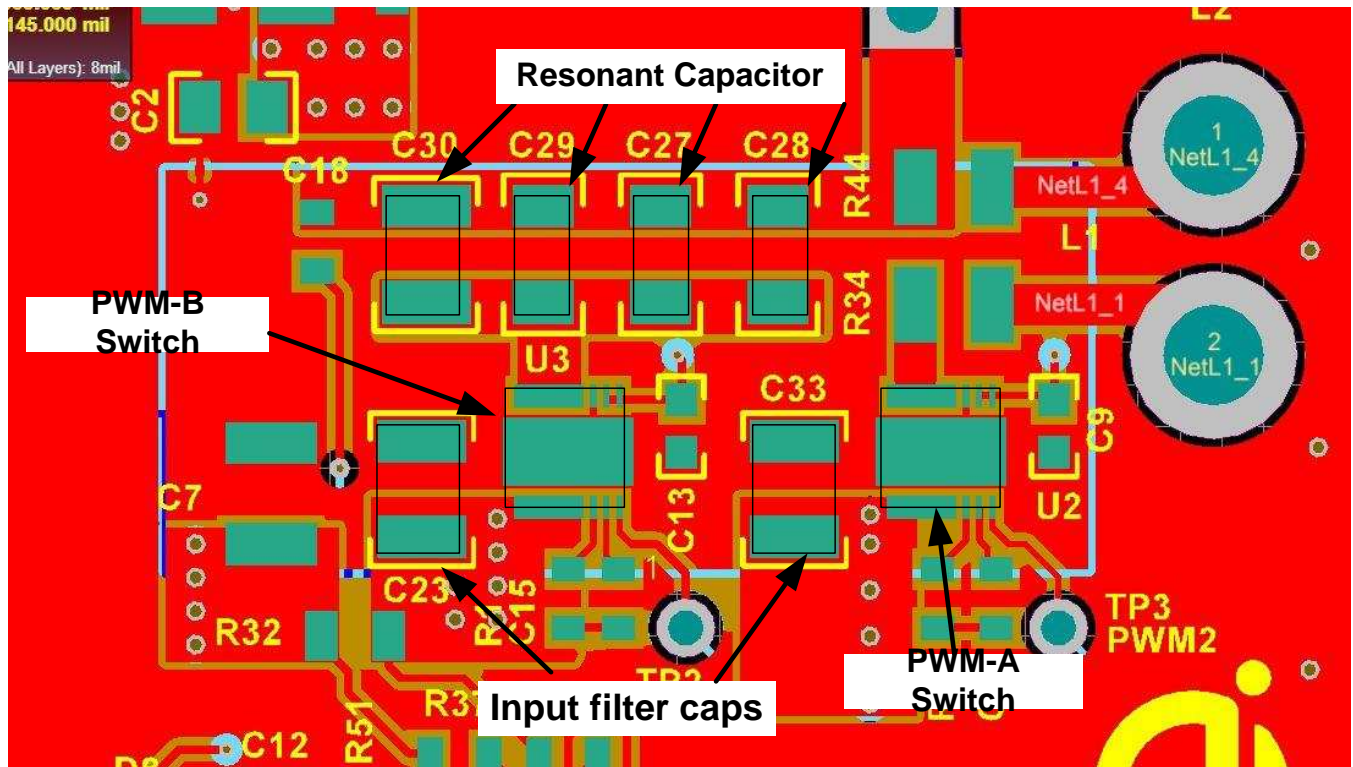

Figure 13. bq500212A Power Section Using CSD9794Q4M or CSD97376Q4M Power Stage

11 Device and Documentation Support

11.1 Device Support

11.1.1 Third-Party Products Disclaimer

TI'S PUBLICATION OF INFORMATION REGARDING THIRD-PARTY PRODUCTS OR SERVICES DOES NOT CONSTITUTE AN ENDORSEMENT REGARDING THE SUITABILITY OF SUCH PRODUCTS OR SERVICES OR A WARRANTY, REPRESENTATION OR ENDORSEMENT OF SUCH PRODUCTS OR SERVICES, EITHER ALONE OR IN COMBINATION WITH ANY TI PRODUCT OR SERVICE.

11.2 Documentation Support

11.2.1 Related Documentation

For related documentation see the following:

- [Building a Wireless Power Transmitter](#) (SLUA635)
- Wireless Power Consortium, www.wirelesspowerconsortium.com
- [Integrated Wireless Power Supply Receiver, Qi \(Wireless Power Consortium\) Compliant](#) (SLUSAY6)

11.3 Receiving Notification of Documentation Updates

To receive notification of documentation updates, navigate to the device product folder on ti.com. In the upper right corner, click on *Alert me* to register and receive a weekly digest of any product information that has changed. For change details, review the revision history included in any revised document.

11.4 Community Resources

The following links connect to TI community resources. Linked contents are provided "AS IS" by the respective contributors. They do not constitute TI specifications and do not necessarily reflect TI's views; see TI's [Terms of Use](#).

TI E2E™ Online Community *TI's Engineer-to-Engineer (E2E) Community*. Created to foster collaboration among engineers. At e2e.ti.com, you can ask questions, share knowledge, explore ideas and help solve problems with fellow engineers.

Design Support *TI's Design Support* Quickly find helpful E2E forums along with design support tools and contact information for technical support.

11.5 Trademarks

Dynamic Power Limiting, E2E are trademarks of Texas Instruments. All other trademarks are the property of their respective owners.

11.6 Electrostatic Discharge Caution



This integrated circuit can be damaged by ESD. Texas Instruments recommends that all integrated circuits be handled with appropriate precautions. Failure to observe proper handling and installation procedures can cause damage.

ESD damage can range from subtle performance degradation to complete device failure. Precision integrated circuits may be more susceptible to damage because very small parametric changes could cause the device not to meet its published specifications.

11.7 Glossary

SLYZ022 — *TI Glossary*.

This glossary lists and explains terms, acronyms, and definitions.

12 Mechanical, Packaging, and Orderable Information

The following pages include mechanical, packaging, and orderable information. This information is the most current data available for the designated devices. This data is subject to change without notice and revision of this document. For browser-based versions of this data sheet, refer to the left-hand navigation.

PACKAGING INFORMATION

Orderable Device	Status (1)	Package Type	Package Drawing	Pins	Package Qty	Eco Plan (2)	Lead finish/ Ball material (6)	MSL Peak Temp (3)	Op Temp (°C)	Device Marking (4/5)	Samples
BQ500212ARGZR	NRND	VQFN	RGZ	48	2500	RoHS & Green	NIPDAU	Level-3-260C-168 HR	0 to 0	BQ500212A	
BQ500212ARGZT	NRND	VQFN	RGZ	48	250	RoHS & Green	NIPDAU	Level-3-260C-168 HR	0 to 0	BQ500212A	

(1) The marketing status values are defined as follows:

ACTIVE: Product device recommended for new designs.

LIFEBUY: TI has announced that the device will be discontinued, and a lifetime-buy period is in effect.

NRND: Not recommended for new designs. Device is in production to support existing customers, but TI does not recommend using this part in a new design.

PREVIEW: Device has been announced but is not in production. Samples may or may not be available.

OBSELETE: TI has discontinued the production of the device.

(2) **RoHS:** TI defines "RoHS" to mean semiconductor products that are compliant with the current EU RoHS requirements for all 10 RoHS substances, including the requirement that RoHS substance do not exceed 0.1% by weight in homogeneous materials. Where designed to be soldered at high temperatures, "RoHS" products are suitable for use in specified lead-free processes. TI may reference these types of products as "Pb-Free".

RoHS Exempt: TI defines "RoHS Exempt" to mean products that contain lead but are compliant with EU RoHS pursuant to a specific EU RoHS exemption.

Green: TI defines "Green" to mean the content of Chlorine (Cl) and Bromine (Br) based flame retardants meet JS709B low halogen requirements of <=1000ppm threshold. Antimony trioxide based flame retardants must also meet the <=1000ppm threshold requirement.

(3) MSL, Peak Temp. - The Moisture Sensitivity Level rating according to the JEDEC industry standard classifications, and peak solder temperature.

(4) There may be additional marking, which relates to the logo, the lot trace code information, or the environmental category on the device.

(5) Multiple Device Markings will be inside parentheses. Only one Device Marking contained in parentheses and separated by a "~" will appear on a device. If a line is indented then it is a continuation of the previous line and the two combined represent the entire Device Marking for that device.

(6) Lead finish/Ball material - Orderable Devices may have multiple material finish options. Finish options are separated by a vertical ruled line. Lead finish/Ball material values may wrap to two lines if the finish value exceeds the maximum column width.

Important Information and Disclaimer:The information provided on this page represents TI's knowledge and belief as of the date that it is provided. TI bases its knowledge and belief on information provided by third parties, and makes no representation or warranty as to the accuracy of such information. Efforts are underway to better integrate information from third parties. TI has taken and continues to take reasonable steps to provide representative and accurate information but may not have conducted destructive testing or chemical analysis on incoming materials and chemicals. TI and TI suppliers consider certain information to be proprietary, and thus CAS numbers and other limited information may not be available for release.

In no event shall TI's liability arising out of such information exceed the total purchase price of the TI part(s) at issue in this document sold by TI to Customer on an annual basis.

TAPE AND REEL INFORMATION

QUADRANT ASSIGNMENTS FOR PIN 1 ORIENTATION IN TAPE

*All dimensions are nominal

Device	Package Type	Package Drawing	Pins	SPQ	Reel Diameter (mm)	Reel Width W1 (mm)	A0 (mm)	B0 (mm)	K0 (mm)	P1 (mm)	W (mm)	Pin1 Quadrant
BQ500212ARGZR	VQFN	RGZ	48	2500	330.0	16.4	7.3	7.3	1.1	12.0	16.0	Q2
BQ500212ARGZT	VQFN	RGZ	48	250	180.0	16.4	7.3	7.3	1.1	12.0	16.0	Q2

TAPE AND REEL BOX DIMENSIONS

*All dimensions are nominal

Device	Package Type	Package Drawing	Pins	SPQ	Length (mm)	Width (mm)	Height (mm)
BQ500212ARGZR	VQFN	RGZ	48	2500	367.0	367.0	38.0
BQ500212ARGZT	VQFN	RGZ	48	250	210.0	185.0	35.0

GENERIC PACKAGE VIEW

RGZ 48

VQFN - 1 mm max height

7 x 7, 0.5 mm pitch

PLASTIC QUADFLAT PACK- NO LEAD

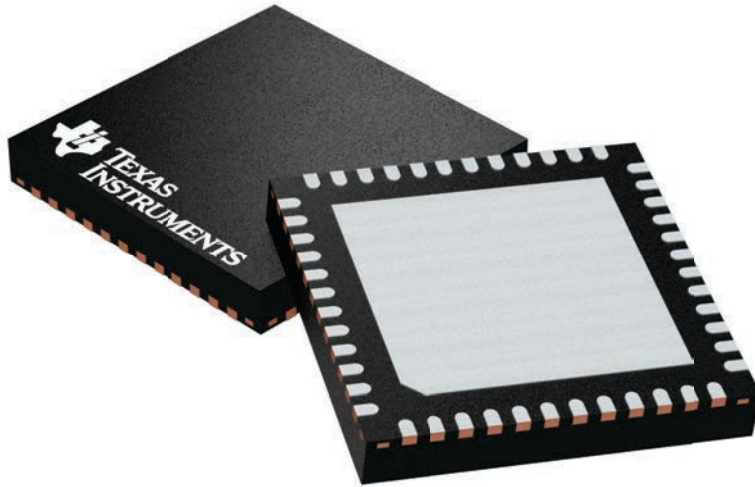

Images above are just a representation of the package family, actual package may vary.
Refer to the product data sheet for package details.

4224671/A

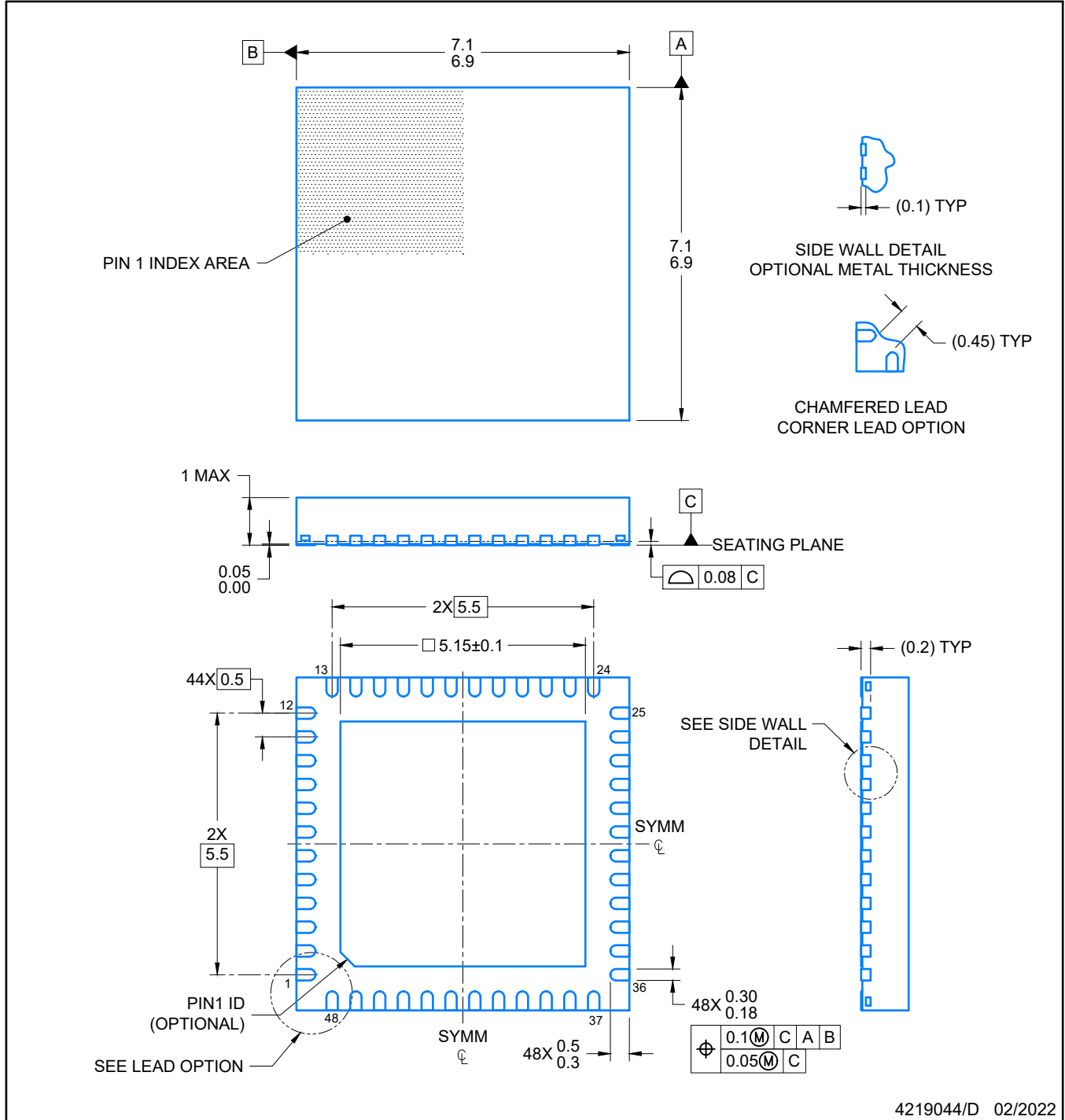

4219044/D 02/2022

NOTES:

1. All linear dimensions are in millimeters. Any dimensions in parenthesis are for reference only. Dimensioning and tolerancing per ASME Y14.5M.
2. This drawing is subject to change without notice.
3. The package thermal pad must be soldered to the printed circuit board for optimal thermal and mechanical performance.

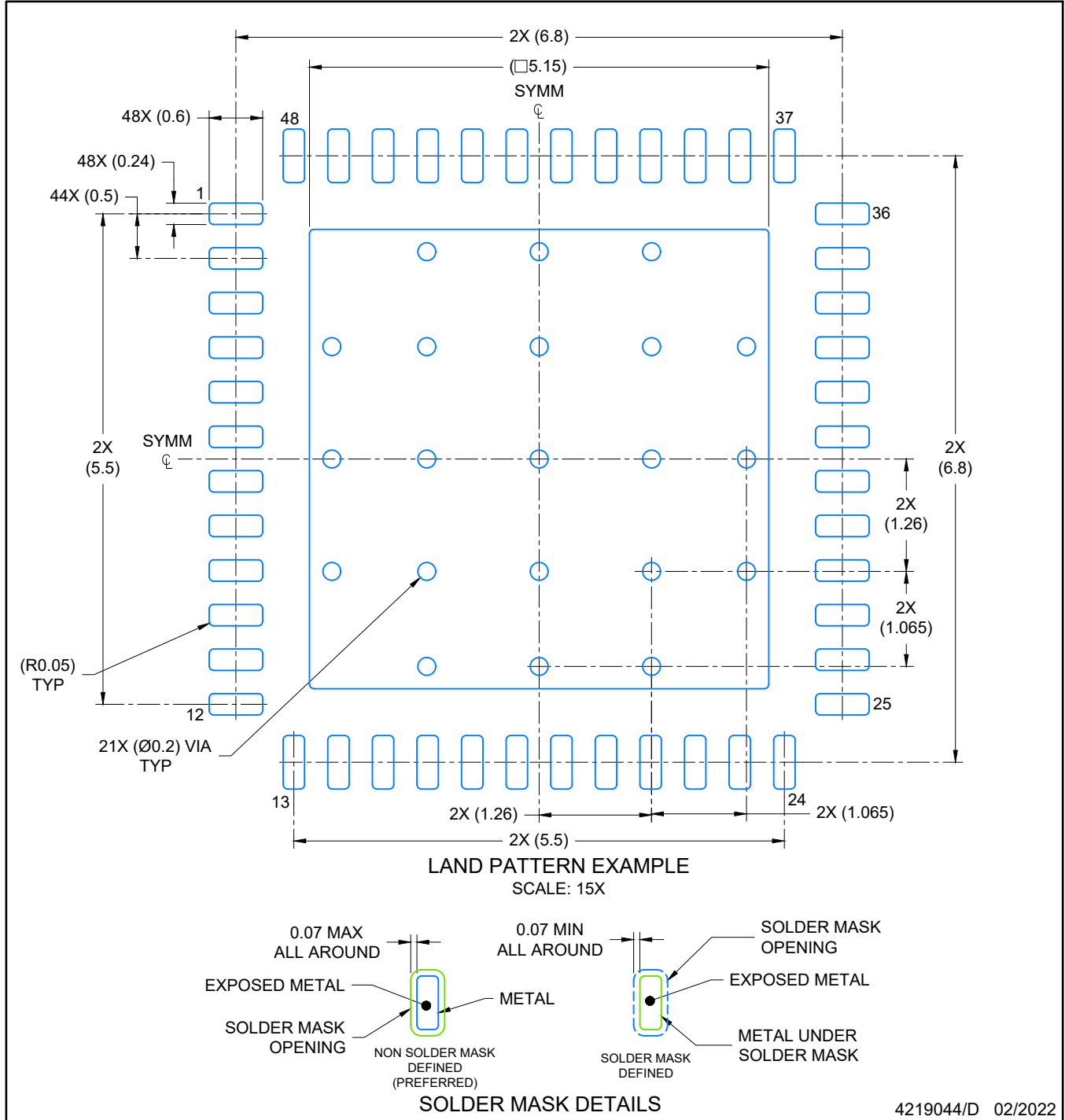

NOTES: (continued)

4. This package is designed to be soldered to a thermal pad on the board. For more information, see Texas Instruments literature number SLUA271 (www.ti.com/lit/slua271).
5. Vias are optional depending on application, refer to device data sheet. If any vias are implemented, refer to their locations shown on this view. It is recommended that vias under paste be filled, plugged or tented.

EXAMPLE STENCIL DESIGN

RGZ0048A

VQFN - 1 mm max height

PLASTIC QUADFLAT PACK- NO LEAD

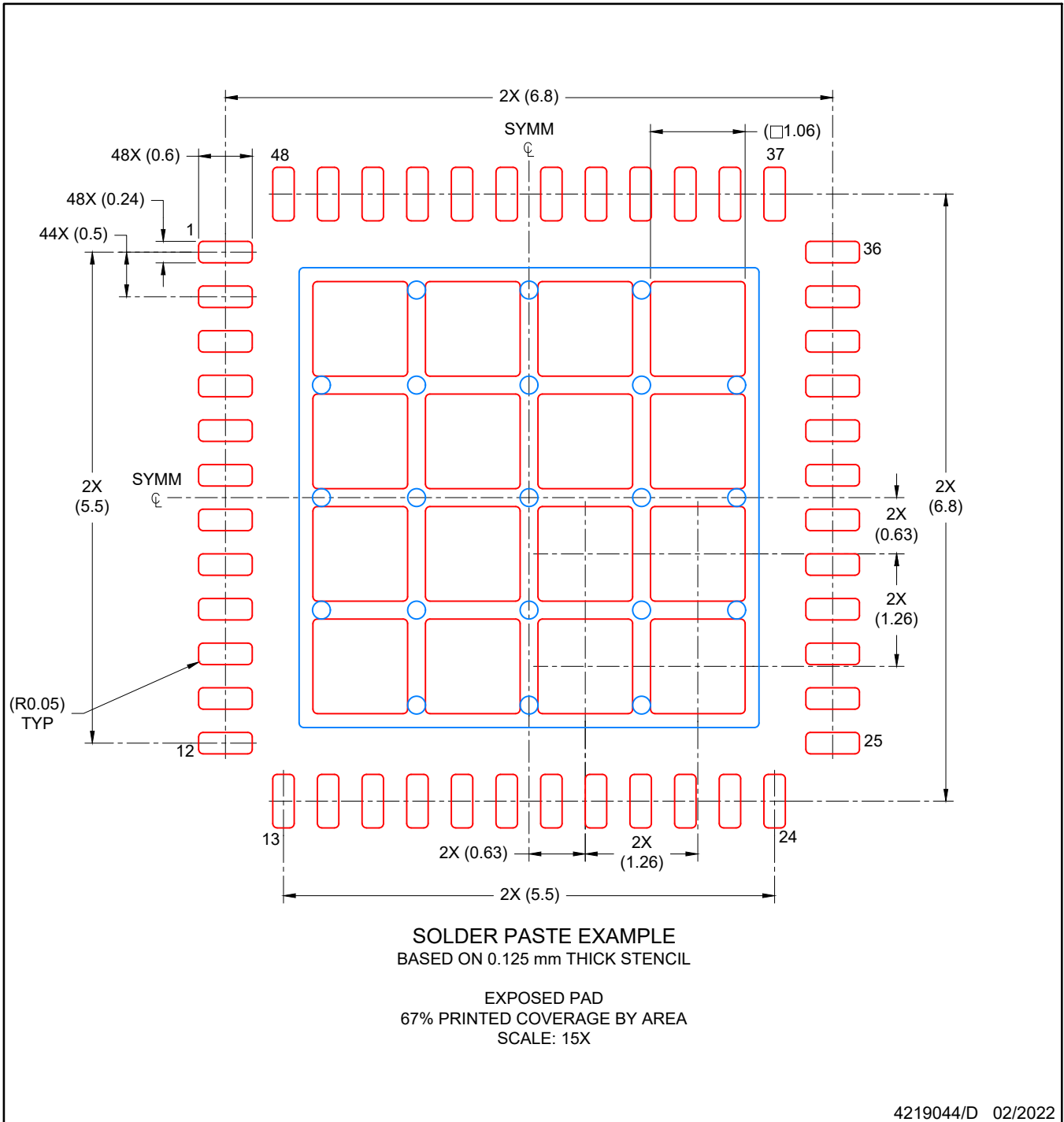

NOTES: (continued)

6. Laser cutting apertures with trapezoidal walls and rounded corners may offer better paste release. IPC-7525 may have alternate design recommendations.

IMPORTANT NOTICE AND DISCLAIMER

TI PROVIDES TECHNICAL AND RELIABILITY DATA (INCLUDING DATA SHEETS), DESIGN RESOURCES (INCLUDING REFERENCE DESIGNS), APPLICATION OR OTHER DESIGN ADVICE, WEB TOOLS, SAFETY INFORMATION, AND OTHER RESOURCES "AS IS" AND WITH ALL FAULTS, AND DISCLAIMS ALL WARRANTIES, EXPRESS AND IMPLIED, INCLUDING WITHOUT LIMITATION ANY IMPLIED WARRANTIES OF MERCHANTABILITY, FITNESS FOR A PARTICULAR PURPOSE OR NON-INFRINGEMENT OF THIRD PARTY INTELLECTUAL PROPERTY RIGHTS.

These resources are intended for skilled developers designing with TI products. You are solely responsible for (1) selecting the appropriate TI products for your application, (2) designing, validating and testing your application, and (3) ensuring your application meets applicable standards, and any other safety, security, regulatory or other requirements.

These resources are subject to change without notice. TI grants you permission to use these resources only for development of an application that uses the TI products described in the resource. Other reproduction and display of these resources is prohibited. No license is granted to any other TI intellectual property right or to any third party intellectual property right. TI disclaims responsibility for, and you will fully indemnify TI and its representatives against, any claims, damages, costs, losses, and liabilities arising out of your use of these resources.

TI's products are provided subject to [TI's Terms of Sale](#) or other applicable terms available either on ti.com or provided in conjunction with such TI products. TI's provision of these resources does not expand or otherwise alter TI's applicable warranties or warranty disclaimers for TI products.

TI objects to and rejects any additional or different terms you may have proposed.

Mailing Address: Texas Instruments, Post Office Box 655303, Dallas, Texas 75265
Copyright © 2022, Texas Instruments Incorporated

Looking for pricing, stock, or lifecycle information?

Click below to explore more details on WIN SOURCE:

 [View BQ500212ARGZR on WIN SOURCE](#)

 [Texas Instruments](#) Information

Optimize Your Supply Chain with WIN SOURCE Solutions

-  Global Sourcing Solution
-  Obsolete Management
-  Cost Control Management
-  Shortage Management
-  Alternative Solution
-  Excess Inventory Management