



**THE DATASHEET OF  
580L24C02CAT**







## Electrical Specifications

### Operating Conditions

PARAMETER	SYMBOL	CONDITIONS	MIN	TYP	MAX	UNIT
Maximum Supply Voltage	V <sub>CC</sub>	-	-0.6	-	4.6	V
Maximum Control Voltage	V <sub>C</sub>	-	-0.5	-	V <sub>CC</sub>	V
Supply Voltage	V <sub>CC</sub>	±5%	2.36	2.5	2.63	V
			2.85	3.0	3.15	
			3.14	3.3	3.47	
Supply Current	I <sub>CC</sub>	Typical Measured @ 26MHz	-	3.0	6.0	mA
Output Load	R <sub>L</sub> //C <sub>L</sub>	-	10k Ohm//10pF		-	-
Operating Temperature	T <sub>A</sub>	-	0		+50	°C
			-10		+60	
			-20	+25	+70	
			-30		+85	
			-40		+85	
Storage Temperature	T <sub>STG</sub>	-	-40	-	+85	°C

### Frequency Stability

PARAMETER	SYMBOL	CONDITIONS	MIN	TYP	MAX	UNIT
Frequency Range	f <sub>0</sub>	-		10 - 52		MHz
Frequency Stability						
Overall Frequency Stability	Δf/f <sub>0</sub>	Reference to f <sub>0</sub> , Including 20 Years Aging	-4.6	-	4.6	ppm
Initial Calibration		Calibration @ +25°C, At Time of Shipment	-0.8	-	0.8	ppm
Temperature Only <sup>1</sup>	Δf/f <sub>25</sub>	[Fmax - Fmin]/2, Over -40°C to +85°C	-0.28	-	0.28	ppm
Voltage Coefficient	Δf/f <sub>25</sub>	Supply Voltage, ±5%	-0.16	-	0.16	ppm
Load Coefficient		Load, ±10%	-0.30	-	0.30	ppm
Aging	Δf/f <sub>25</sub>	20 Years @ +40°C, Nominal V <sub>CC</sub> and V <sub>C</sub>	-3.0	-	3.0	ppm
Holdover	Δf/f <sub>0</sub>	[Fmax - Fmin]/2, Over 24 Hours	-0.4	-	0.4	ppm

1.] See Ordering Information for additional stability options.

### Output Parameters

PARAMETER	SYMBOL	CONDITIONS	MIN	TYP	MAX	UNIT
Output Type	-	DC Coupled		Clipped Sine		-
Output Voltage Levels	V <sub>O</sub>	-	0.8	-	-	V <sub>p-p</sub>
Output Duty Cycle	SYM	@ 50% Level	45	-	55	%
Start Up Time	T <sub>S</sub>	-	-	5	10	ms
Enable Function Standby						
Enable Input Voltage	V <sub>IH</sub>	Pin 6 Logic '1', Output Enabled	0.7V <sub>CC</sub>	-	-	V
Disable Input Voltage	V <sub>IL</sub>	Pin 6 Logic '0', Output Disabled	-	-	0.3V <sub>CC</sub>	V
Enable Current	I <sub>STB</sub>	Pin 6 Logic '0', Output Disabled	-	-	10	μA
Enable Time	T <sub>PLZ</sub>	Pin 6 Logic '1'	-	-	10	ms
Phase Noise	-	See Typical Plots	-	-	-	-

## Electrical Specifications

### Control Voltage

PARAMETER	SYMBOL	CONDITIONS	MIN	TYP	MAX	UNIT
Control Voltage	$V_c$	Nominal $V_{CC}$	0.5	1.5	2.5	V
Frequency Tuning [VCTCXO Only]	$\Delta f/f_0$	Specified $V_c$ Range	$\pm 5$	-	$\pm 15$	ppm
Linearity	L	Best Straight Line Fit	-	-	$\pm 10$	%
Input Impedance	$Z_{Vc}$	-	100	-	-	kOhms
Transfer Function	-	-	-	Positive	-	-

### Enable Truth Table

Pin 6	Pin 5
Logic '1'	Output Enabled
Open	Output Enabled
Logic '0'	Output Disabled, High Impedance

### Test Circuit

Clipped Sine – w/o Enable Function

\* DC-Cut Capacitor: Add 1000pF capacitor between the TCXO output and input of load.

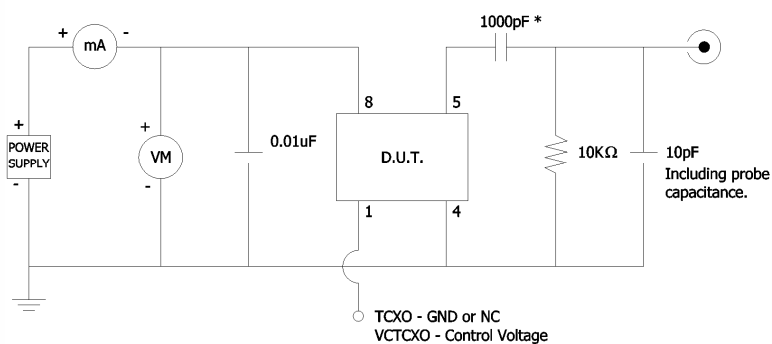

Clipped Sine – w/ Enable Function

\* DC-Cut Capacitor: Add 1000pF capacitor between the TCXO output and input of load.

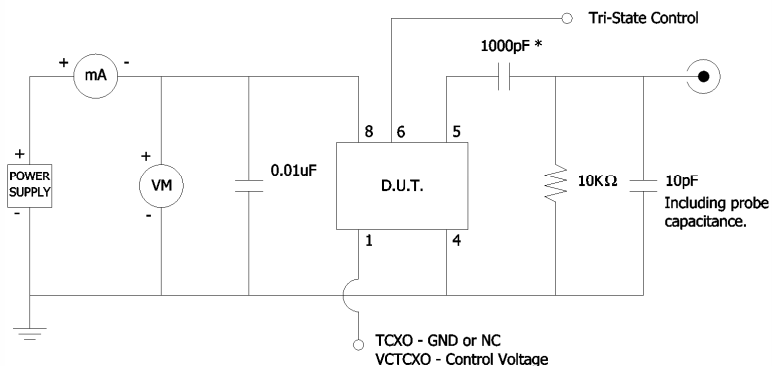

## Electrical Specifications

### Performance Data

#### Phase Noise [typical]

24.5760MHz,  $V_{CC} = +3.3V$ ,  $T_A = +25^\circ C$

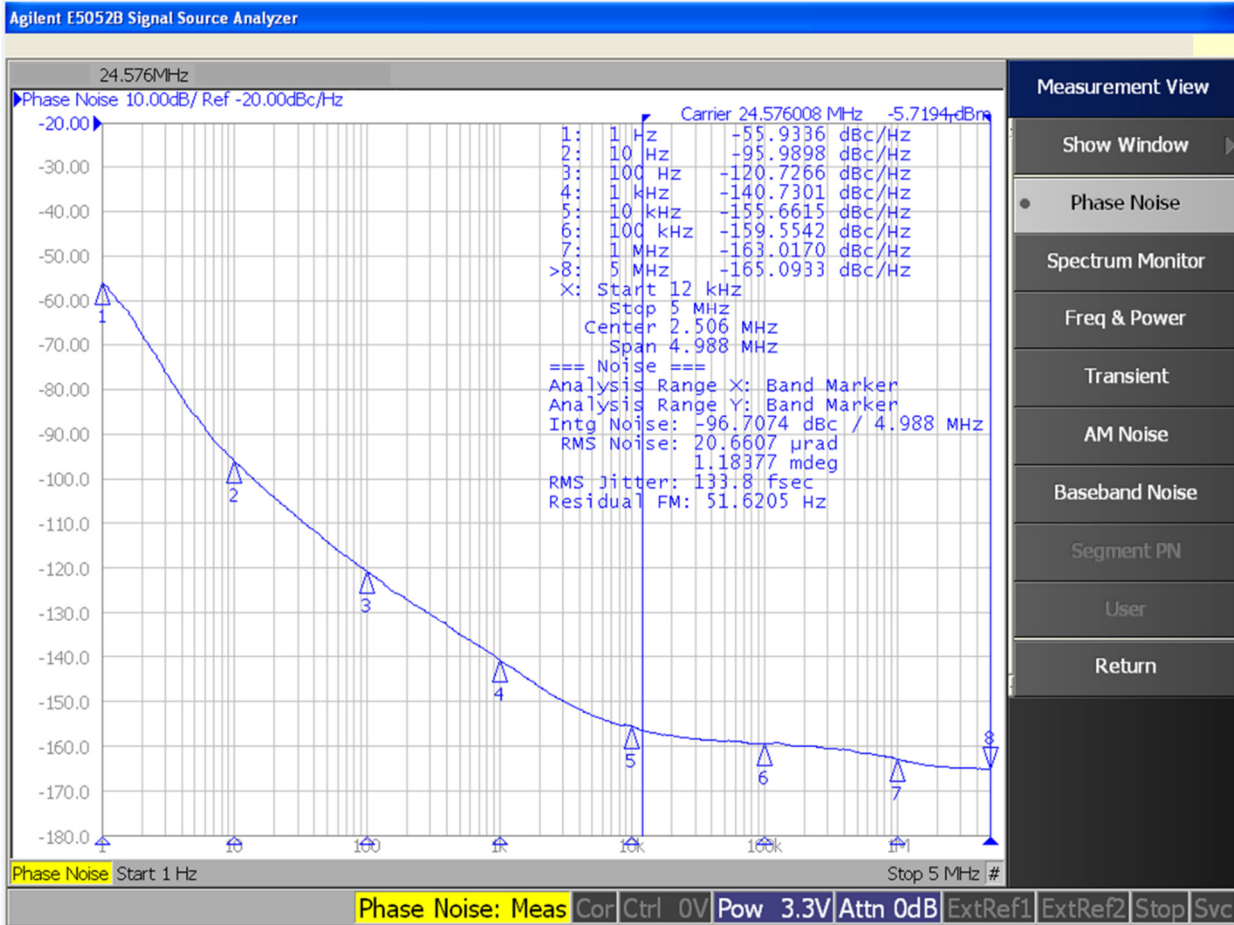

## Electrical Specifications

### Performance Data

Phase Noise [typical]

40MHz,  $V_{CC} = +3.3V$ ,  $V_C = +1.5V$ ,  $T_A = +25^\circ C$

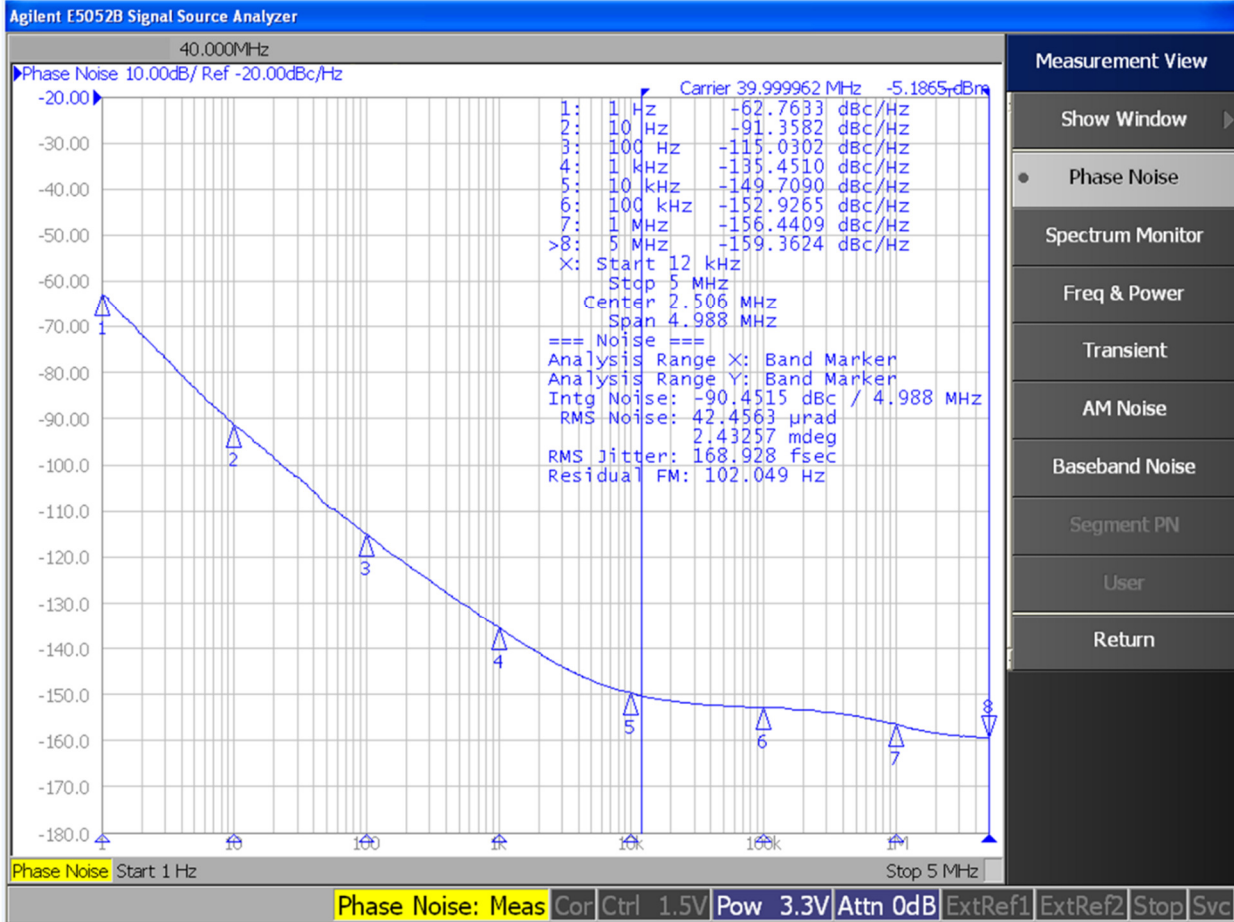

### Mechanical Specifications

Package Drawing – 8-Pad

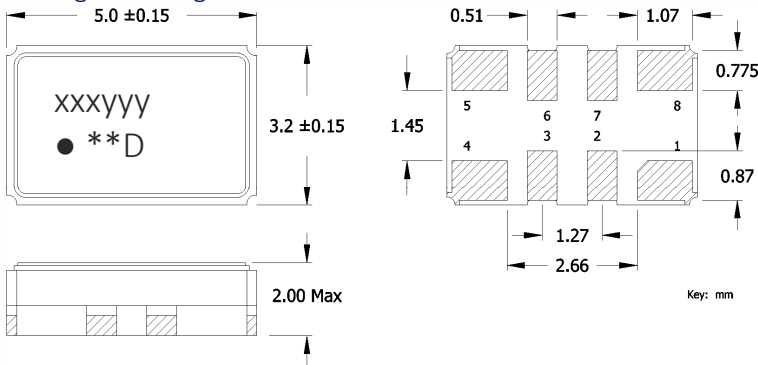

### Marking Information

- xxx – Frequency Code, 3-digits.  
3-digits for frequencies <100MHz  
[See document 016-1454-0, Frequency Code Tables.]
- yyy – Crystal Lot Code or Date Code [optional].
- – Pin 1 Identifier.
- \*\* – Manufacturing site code.
- D – Date Code. See Table I for codes.

Recommended Pad Layout – w/o Enable Function

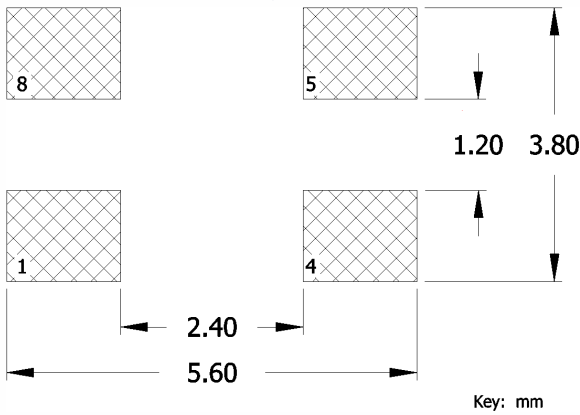

### Notes

- DO NOT make connections to non-labeled pins or castellations as they may have internal connections used in the manufacturing process.
- JEDEC termination code (e4). Barrier-plating is nickel [Ni] with gold [Au] flash plate.
- Reflow conditions per JEDEC J-STD-020; +260°C maximum, 20 seconds.
- MSL = 1.

Recommended Pad Layout – w/ Enable Function

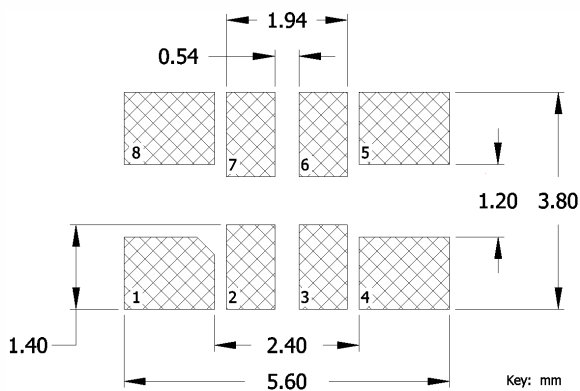



## Mechanical Specifications

### Pin Assignments – 8-Pad Solder Attach

Pin	Symbol	Function
1	V <sub>C</sub>	GND or NC – TCXO [Note 1] Control Voltage – VCTCXO
2	NC	No Connect
3	NC	No Connect
4	GND	Circuit & Package Ground
5	Output	RF Output [Note 2]
6	NC or EOH	No Connect or Optional Enable
7	NC	No Connect
8	V <sub>CC</sub>	Supply Voltage

### Pin Assignments – 4-Pad Solder Attach

Pin	Symbol	Function
1	V <sub>C</sub>	GND or NC – TCXO [Note 1] Control Voltage – VCTCXO
2	GND	Circuit & Package Ground
3	Output	RF Output [Note 2]
4	V <sub>CC</sub>	Supply Voltage

#### Notes

1. Connect to ground for TCXO, no frequency tuning. Pin can be left floating.
2. DC-Cut capacitor required. Add 1000pF capacitor between TCXO output and input of load.

Table I - Date Code, Beginning year 2021

YEAR \ MONTH					JAN	FEB	MAR	APR	MAY	JUN	JUL	AUG	SEP	OCT	NOV	DEC
					A	B	C	D	E	F	G	H	J	K	L	M
2021	2025	2029	2033	2037	N	P	Q	R	S	T	U	V	W	X	Y	Z
2022	2026	2030	2034	2038	a	b	c	d	e	f	g	h	j	k	l	m
2023	2027	2031	2035	2039	n	p	q	r	s	t	u	v	w	x	y	z
2024	2028	2032	2036	2040												

### Packaging - Tape and Reel

#### Tape Drawing

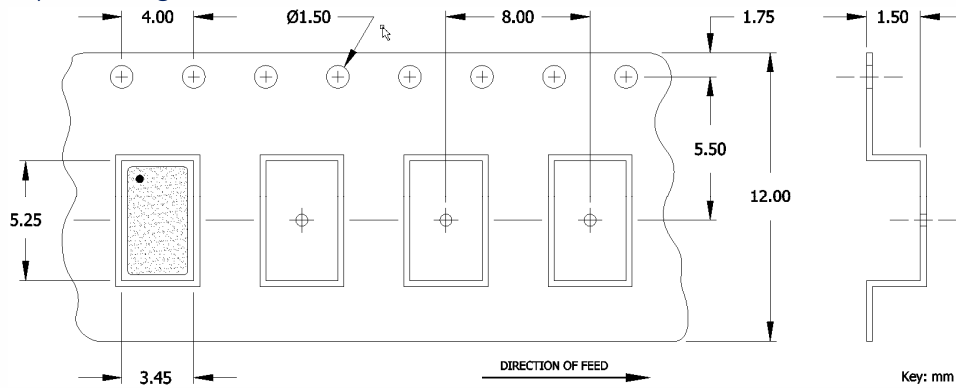

#### Reel Drawing

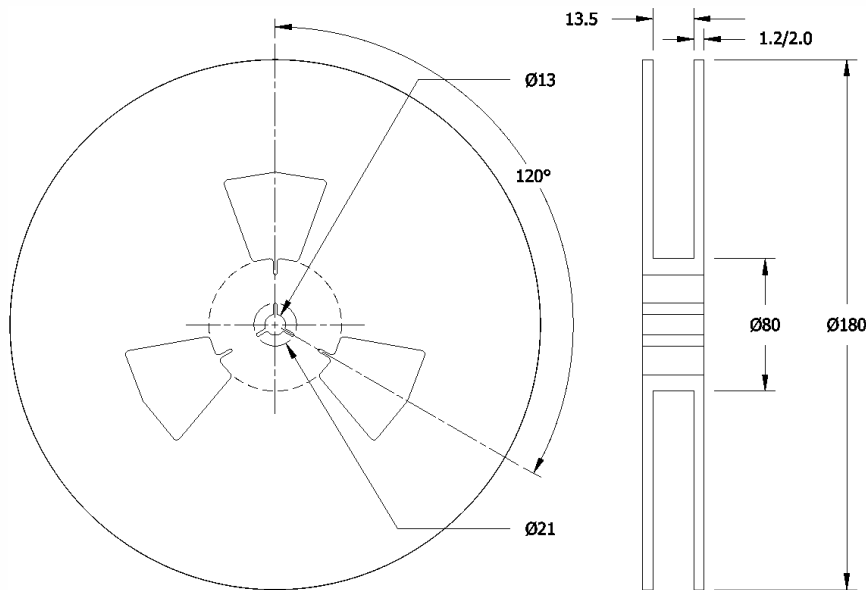

#### Notes

1. Device quantity is 1k pieces per 180mm reel.
2. Complete CTS part number, frequency value and date code information must appear on reel and carton labels.



## Addendum

### Common Frequencies and Frequency Codes – MHz

FREQUENCY	ORDERING CODE	FREQUENCY	ORDERING CODE	FREQUENCY	ORDERING CODE
<b>10.000000</b>	100	25.000000	250	<b>50.000000</b>	500
12.800000	128	26.000000	260	52.000000	520
13.000000	130	27.000000	270		
16.000000	160	30.000000	300		
16.384000	163	<b>30.720000</b>	307		
16.800000	168	32.000000	320		
<b>19.200000</b>	192	36.000000	360		
19.440000	194	38.400000	384		
<b>20.000000</b>	200	38.880000	388		
20.480000	204	<b>40.000000</b>	400		
24.000000	240	48.000000	480		
<b>24.576000</b>	24C	49.152000	491		

Frequencies in **bold** are standard.

## Looking for pricing, stock, or lifecycle information?

Click below to explore more details on WIN SOURCE:

-  [View 580L24C02CAT](#) on WIN SOURCE
-  [CTS-Frequency Controls](#) Information

## Optimize Your Supply Chain with WIN SOURCE Solutions

-  Global Sourcing Solution
-  Obsolete Management
-  Cost Control Management
-  Shortage Management
-  Alternative Solution
-  Excess Inventory Management