



**THE DATASHEET OF
BQ294700DSGR**



bq2947 Overvoltage Protection for 2-Series to 4-Series Cell Li-Ion Batteries with External Delay Capacitor

1 Features

- 2-, 3-, and 4-Series Cell Overvoltage Protection
- External Capacitor-Programmed Delay Timer
- Factory Programmed OVP Threshold (Threshold Range 3.85 V to 4.6 V)
- Output Options: Active High or Open Drain Active Low
- High-Accuracy Overvoltage Protection: ± 10 mV
- Low Power Consumption $I_{CC} \approx 1$ μ A ($V_{CELL(ALL)} < V_{PROTECT}$)
- Low Leakage Current Per Cell Input < 100 nA
- Small Package Footprint
 - 8-Pin WSON (2.00 mm x 2.00 mm)

2 Applications

- Notebooks
- UPS Battery Backup

3 Description

The bq2947 family is an overvoltage monitor and protector for Li-Ion battery pack systems. Each cell is monitored independently for an overvoltage condition.

In the bq2947 device, an external delay timer is initiated upon detection of an overvoltage condition on any cell. Upon expiration of the delay timer, the output is triggered into its active state (either high or low, depending on the configuration). The external delay timer feature also includes the ability to detect an open or shorted delay capacitor on the CD pin, which will similarly trigger the output driver in an overvoltage condition.

For quicker production-line testing, the bq2947 device provides a Customer Test Mode with reduced delay time.

Device Information⁽¹⁾

PART NUMBER	PACKAGE	BODY SIZE (NOM)
bq294700	WSON (8)	2.00 mm x 2.00 mm

(1) For all available packages, see the orderable addendum at the end of the data sheet.

Simplified Schematic

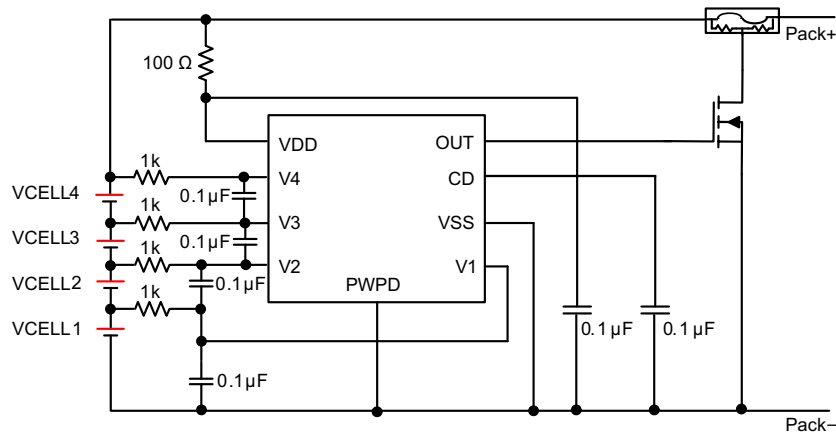

Copyright © 2017, Texas Instruments Incorporated



Table of Contents

1 Features	1	8.4 Device Functional Modes.....	10
2 Applications	1	9 Application and Implementation	12
3 Description	1	9.1 Application Information.....	12
4 Revision History	2	9.2 Typical Applications	12
5 Device Options	3	10 Power Supply Recommendations	15
6 Pin Configuration and Functions	4	11 Layout	15
7 Specifications	4	11.1 Layout Guidelines	15
7.1 Absolute Maximum Ratings	4	11.2 Layout Example	15
7.2 ESD Ratings.....	4	12 Device and Documentation Support	16
7.3 Recommended Operating Conditions.....	5	12.1 Documentation Support	16
7.4 Thermal Information	5	12.2 Receiving Notification of Documentation Updates	16
7.5 Electrical Characteristics.....	5	12.3 Community Resources.....	16
7.6 Typical Characteristics.....	7	12.4 Trademarks	16
8 Detailed Description	8	12.5 Electrostatic Discharge Caution.....	16
8.1 Overview	8	12.6 Glossary	16
8.2 Functional Block Diagram	8	13 Mechanical, Packaging, and Orderable	
8.3 Feature Description.....	8	Information	16

4 Revision History

NOTE: Page numbers for previous revisions may differ from page numbers in the current version.

Changes from Revision H (February 2018) to Revision I	Page
• Added bq294713 to the <i>Device Options table</i>	3
• Added bq294713 to the <i>Electrical Characteristics</i>	5
Changes from Revision G (November 2017) to Revision H	Page
• Changed bq294712 to Production Data in the <i>Device Options table</i>	3
Changes from Revision F (January 2017) to Revision G	Page
• Deleted bq294709 from the <i>Device Options table</i>	3
• Added bq294712 to the <i>Device Options table</i>	3
• Added bq294712 and deleted bq294709 in <i>Electrical Characteristics</i>	5
Changes from Revision E (February 2016) to Revision F	Page
• Added bq294711 to the <i>Device Options table</i>	3
• Added <i>Receiving Notification of Documentation Updates</i>	16
Changes from Revision D (November 2015) to Revision E	Page
• Changed bq297406 device status From: Product Preview To: Active in the <i>Device Options table</i>	3
Changes from Revision C (November 2015) to Revision D	Page
• Changed the device number to bq2947	1
• Deleted the <i>Related Links</i> table from the <i>Device and Documentation Support</i> section.....	16

Changes from Revision B (August 2014) to Revision C **Page**

- Added preview footnote to the *Device Options table* **3**
 - Added bq294708 to the *Device Options table*..... **3**
-

Changes from Revision A (June 2013) to Revision B **Page**

- Added *ESD Ratings table, Feature Description section, Device Functional Modes, Application and Implementation section, Power Supply Recommendations section, Layout section, Device and Documentation Support section, and Mechanical, Packaging, and Orderable Information section* **1**
-

Changes from Original (September 2012) to Revision A **Page**

- Added the bq294707 device to Production Data **1**
-

5 Device Options

PART NUMBER	OVP (V)	OV HYSTERESIS	OUTPUT DRIVE
bq294700	4.350	0.300	CMOS Active High
bq294701	4.250	0.300	CMOS Active High
bq294702	4.300	0.300	CMOS Active High
bq294703	4.325	0.300	CMOS Active High
bq294704	4.400	0.300	CMOS Active High
bq294705	4.450	0.300	CMOS Active High
bq294706	4.550	0.300	CMOS Active High
bq294707	4.225	0.050	NCH Open Drain Active Low
bq294708	4.500	0.300	CMOS Active High
bq294711	4.220	0.300	CMOS Active High
bq294712 ⁽¹⁾	4.125	0.300	CMOS Active High
bq294713 ⁽¹⁾	4.600	0.300	CMOS Active High
bq2947	3.850–4.60	0–0.300	CMOS Active High or Open Drain Active Low

(1) Contact TI for more information.

6 Pin Configuration and Functions

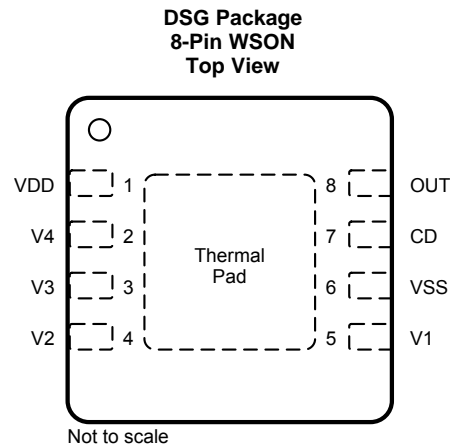

Pin Functions

NUMBER	NAME	TYPE	DESCRIPTION
1	VDD	P	Power supply input
2	V4	IA	Sense input for positive voltage of the fourth cell from the bottom of the stack
3	V3	IA	Sense input for positive voltage of the third cell from the bottom of the stack
4	V2	IA	Sense input for positive voltage of the second cell from the bottom of the stack
5	V1	IA	Sense input for positive voltage of the lowest cell in the stack
6	VSS	P	Electrically connected to IC ground and negative terminal of the lowest cell in the stack
7	CD	OA ⁽¹⁾	External capacitor connection for delay timer
8	OUT	OA	Analog Output drive for overvoltage fault signal. Active High or Open Drain Active Low
PowerPAD™		P	TI recommends connecting the exposed pad to VSS on the PCB.

(1) IA = Input Analog, OA = Output Analog, P = Power Connection

7 Specifications

7.1 Absolute Maximum Ratings

Over operating free-air temperature range (unless otherwise noted)⁽¹⁾

		MIN	MAX	UNIT
Supply voltage	VDD–VSS	–0.3	30	V
Input voltage	V4–V3, V3–V2, V2–V1, V1–VSS, or CD–VSS	–0.3	30	V
Output voltage	OUT–VSS	–0.3	30	V
Continuous total power dissipation, P _{TOT}		See Thermal Information		
Lead temperature (soldering, 10 s), T _{SOLDER}			300	°C
Storage temperature, T _{stg}		–65	150	

(1) Stresses beyond those listed under *Absolute Maximum Ratings* may cause permanent damage to the device. These are stress ratings only, which do not imply functional operation of the device at these or any other conditions beyond those indicated under *Recommended Operating Conditions*. Exposure to absolute-maximum-rated conditions for extended periods may affect device reliability.

7.2 ESD Ratings

			VALUE	UNIT
V _(ESD)	Electrostatic discharge	Human body model (HBM), per ANSI/ESDA/JEDEC JS-001 ⁽¹⁾	±2000	V
		Charged device model (CDM), per JEDEC specification JESD22-C101 ⁽²⁾	±500	

(1) JEDEC document JEP155 states that 500-V HBM allows safe manufacturing with a standard ESD control process.

(2) JEDEC document JEP157 states that 250-V CDM allows safe manufacturing with a standard ESD control process.

7.3 Recommended Operating Conditions

Over-operating free-air temperature range (unless otherwise noted)

	MIN	MAX	UNIT
Supply voltage, V_{DD}	3	20	V
Input voltage range V4–V3, V3–V2, V2–V1, V1–VSS, or CD–VSS	0	5	V
Operating ambient temperature range, T_A	–40	110	°C

7.4 Thermal Information

THERMAL METRIC ⁽¹⁾		bq2947		UNIT
		WSON		
		8 PINS		
$R_{\theta JA}$	Junction-to-ambient thermal resistance	62		°C/W
$R_{\theta JC(top)}$	Junction-to-case(top) thermal resistance	72		°C/W
$R_{\theta JB}$	Junction-to-board thermal resistance	32.5		°C/W
Ψ_{JT}	Junction-to-top characterization parameter	1.6		°C/W
Ψ_{JB}	Junction-to-board characterization parameter	33		°C/W
$R_{\theta JC(bottom)}$	Junction-to-case(bottom) thermal resistance	10		°C/W

(1) For more information about traditional and new thermal metrics, see the [Semiconductor and IC Package Thermal Metrics](#) application report.

7.5 Electrical Characteristics

Typical values stated where $T_A = 25^\circ\text{C}$ and $V_{DD} = 14.4\text{ V}$, MIN/MAX values stated where $T_A = -40^\circ\text{C}$ to $+110^\circ\text{C}$ and $V_{DD} = 3\text{ V}$ to 20 V (unless otherwise noted).

PARAMETER		TEST CONDITIONS	MIN	TYP	MAX	UNIT
VOLTAGE PROTECTION THRESHOLDS						
V_{OV}	$V_{(PROTECT)}$ Overvoltage Detection	bq294700, $R_{IN} = 1\text{ k}\Omega$		4.350		V
		bq294701, $R_{IN} = 1\text{ k}\Omega$		4.250		V
		bq294702, $R_{IN} = 1\text{ k}\Omega$		4.300		V
		bq294703, $R_{IN} = 1\text{ k}\Omega$		4.325		V
		bq294704, $R_{IN} = 1\text{ k}\Omega$		4.400		V
		bq294705, $R_{IN} = 1\text{ k}\Omega$		4.450		V
		bq294706, $R_{IN} = 1\text{ k}\Omega$		4.550		V
		bq294707, $R_{IN} = 1\text{ k}\Omega$		4.225		V
		bq294708, $R_{IN} = 1\text{ k}\Omega$		4.500		V
		bq294711, $R_{IN} = 1\text{ k}\Omega$		4.220		V
		bq294712 ⁽¹⁾ , $R_{IN} = 1\text{ k}\Omega$		4.125		V
bq294713 ⁽¹⁾ , $R_{IN} = 1\text{ k}\Omega$		4.600		V		
V_{HYS}	OV Detection Hysteresis	bq2947 ⁽²⁾	250	300	400	mV
V_{OA}	OV Detection Accuracy	$T_A = 25^\circ\text{C}$	–10		10	mV
$V_{OADRIFT}$	OV Detection Accuracy Across Temperature	$T_A = -40^\circ\text{C}$	–40		40	mV
		$T_A = 0^\circ\text{C}$	–20		20	mV
		$T_A = 60^\circ\text{C}$	–24		24	mV
		$T_A = 110^\circ\text{C}$	–54		54	mV
SUPPLY AND LEAKAGE CURRENT						
I_{DD}	Supply Current	(V4–V3) = (V3–V2) = (V2–V1) = (V1–VSS) = 4.0 V at $T_A = 25^\circ\text{C}$ (See Figure 10 .)		1	2	μA
I_{IN}	Input Current at Vx Pins	(V4–V3) = (V3–V2) = (V2–V1) = (V1–VSS) = 4.0 V at $T_A = 25^\circ\text{C}$ (See Figure 10 .)	–0.1		0.1	μA

(1) Contact TI for more information.

(2) Future option, contact TI.

Electrical Characteristics (continued)

Typical values stated where $T_A = 25^\circ\text{C}$ and $V_{DD} = 14.4\text{ V}$, MIN/MAX values stated where $T_A = -40^\circ\text{C}$ to $+110^\circ\text{C}$ and $V_{DD} = 3\text{ V}$ to 20 V (unless otherwise noted).

PARAMETER		TEST CONDITIONS	MIN	TYP	MAX	UNIT
I_{CELL}	Input Current (ALL Vx and VDD Input Pins)	Current Consumption at Power down, $(V4-V3) = (V3-V2) = (V2-V1) = (V1-VSS) = 2.30\text{ V}$ at $T_A = 25^\circ\text{C}$		1.1		μA
OUTPUT DRIVE OUT, CMOS ACTIVE HIGH VERSIONS ONLY						
V_{OUT}	Output Drive Voltage, Active High	$(V4-V3)$, $(V3-V2)$, $(V2-V1)$, or $(V1-VSS) > V_{OV}$, $V_{DD} = 14.4\text{ V}$, $I_{OH} = 100\ \mu\text{A}$	6			V
		If three of four cells are short circuited, only one cell remains powered and $> V_{OV}$, $V_{DD} = V_x$ (cell voltage), $I_{OH} = 100\ \mu\text{A}$		$V_{DD} - 0.3$		V
		$(V4-V3)$, $(V3-V2)$, $(V2-V1)$, and $(V1-VSS) < V_{OV}$, $V_{DD} = 14.4\text{ V}$, $I_{OL} = 100\ \mu\text{A}$ measured into OUT pin.		250	400	mV
I_{OUTH}	OUT Source Current (during OV)	$(V4-V3)$, $(V3-V2)$, $(V2-V1)$, or $(V1-VSS) > V_{OV}$, $V_{DD} = 14.4\text{ V}$, $OUT = 0\text{ V}$, measured out of OUT pin.			4.5	mA
I_{OUTL}	OUT Sink Current (no OV)	$(V4-V3)$, $(V3-V2)$, $(V2-V1)$, and $(V1-VSS) < V_{OV}$, $V_{DD} = 14.4\text{ V}$, $OUT = V_{DD}$, measured into OUT pin. Pull resistor $R_{PU} = 5\text{ k}\Omega$ to $V_{DD} = 14.4\text{ V}$	0.5		14	mA
OUTPUT DRIVE OUT, CMOS OPEN DRAIN ACTIVE LOW VERSIONS ONLY						
V_{OUT}	Output Drive Voltage, Active High	$(V4-V3)$, $(V3-V2)$, $(V2-V1)$, and $(V1-VSS) < V_{OV}$, $V_{DD} = 14.4\text{ V}$, $I_{OL} = 100\ \mu\text{A}$ measured into OUT pin.		250	400	mV
I_{OUTL}	OUT Sink Current (no OV)	$(V4-V3)$, $(V3-V2)$, $(V2-V1)$, and $(V1-VSS) < V_{OV}$, $V_{DD} = 14.4\text{ V}$, $OUT = V_{DD}$, measured into OUT pin. Pull resistor $R_{PU} = 5\text{ k}\Omega$ to $V_{DD} = 14.4\text{ V}$	0.5		14	mA
I_{OUTLK}	OUT pin leakage	$(V4-V3)$, $(V3-V2)$, $(V2-V1)$, and $(V1-VSS) < V_{OV}$, $V_{DD} = 14.4\text{ V}$, $OUT = V_{DD}$, measured into OUT pin.			100	nA
DELAY TIMER						
t_{CD}	OV Delay Time	$C_{CD} = 0.1\ \mu\text{F}$ (see Equation 1)	1	1.5	2	s
t_{CD_GND}	OV Delay Time with CD pin = 0 V	Delay due to C_{CD} capacitor shorted to ground for Customer Test Mode	20		170	ms

7.6 Typical Characteristics

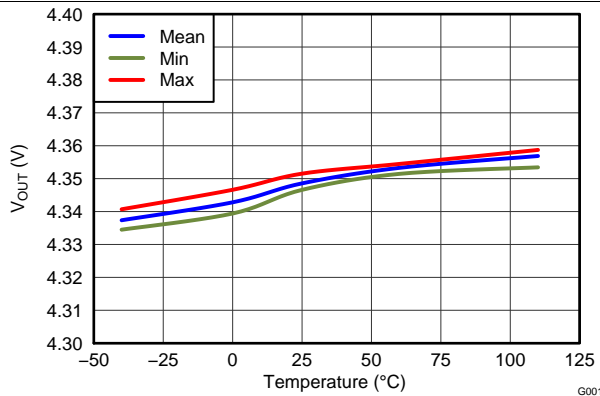

Figure 1. Overvoltage Threshold (Nominal = 4.35 V) vs. Temperature

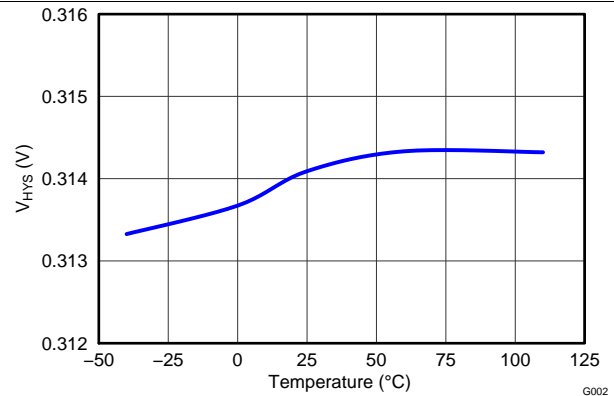

Figure 2. Hysteresis V_{HYS} vs. Temperature

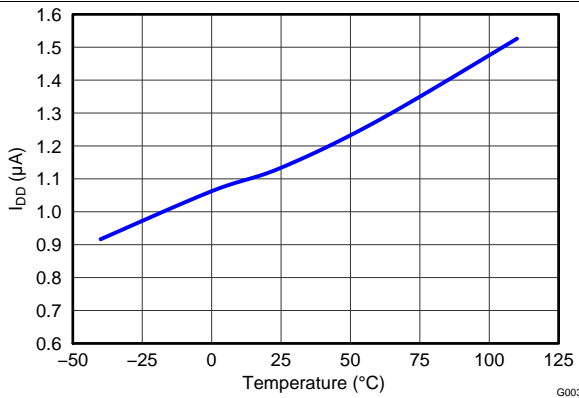

Figure 3. I_{DD} Current Consumption vs. Temperature at $V_{DD} = 16\text{ V}$

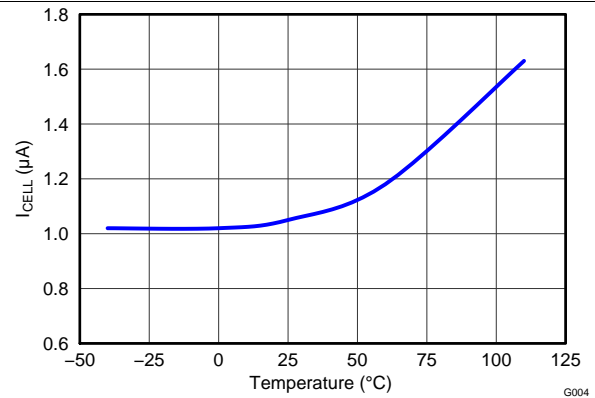

Figure 4. I_{CELL} vs. Temperature at $V_{CELL} = 9.2\text{ V}$

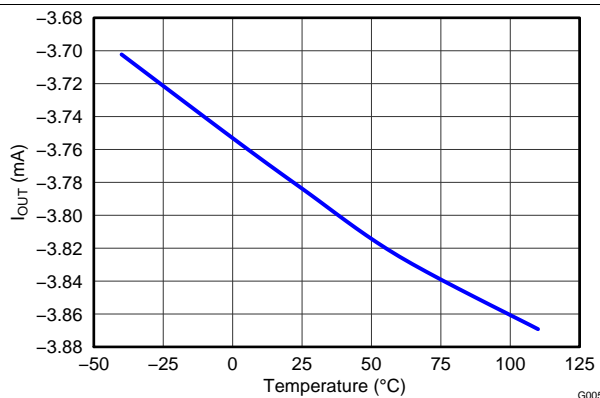

Figure 5. Output Current I_{OUT} vs. Temperature

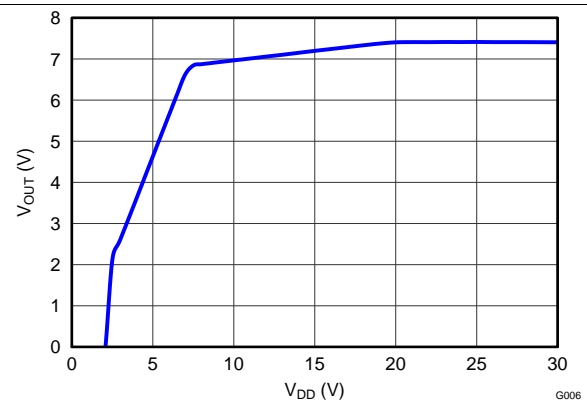

Figure 6. V_{OUT} vs. V_{DD}

8 Detailed Description

8.1 Overview

The bq2947 is a second level overvoltage (OV) protector. Each cell is monitored independently by comparing the actual cell voltage to a protection voltage threshold, V_{OV} . The protection threshold is preprogrammed at the factory with a range between 3.85 V and 4.65 V.

8.2 Functional Block Diagram

The Functional Block Diagram shows a CMOS Active High configuration.

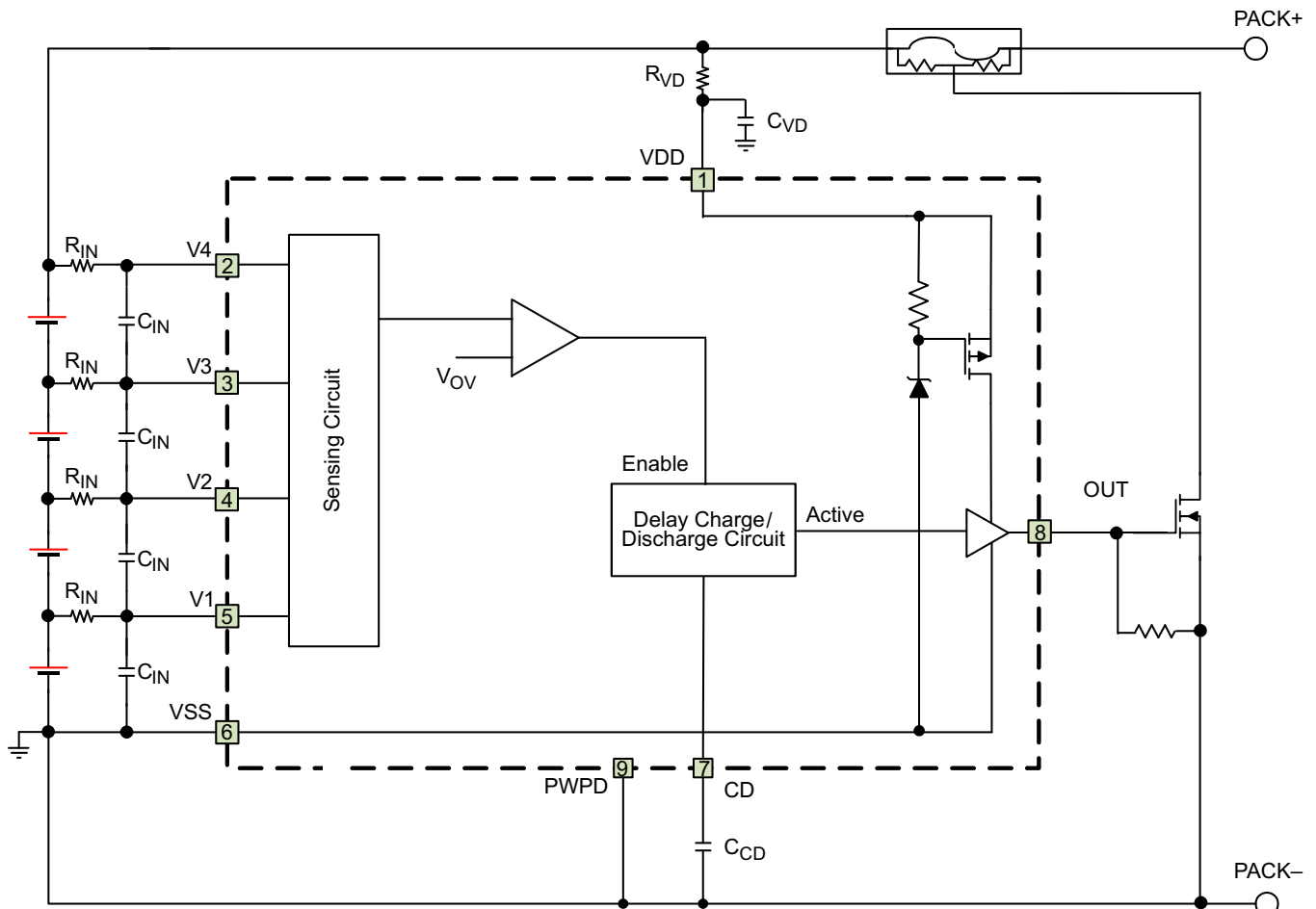

NOTE

In the case of an Open Drain Active Low configuration, an external pull-up resistor is required on the OUT terminal.

8.3 Feature Description

In the bq2947 family of devices, if any cell voltage exceeds the programmed OV value, a timer circuit is activated. This timer circuit charges the CD pin to a nominal value, then slowly discharges it with a fixed current back down to VSS. When the CD pin falls below a nominal threshold near VSS, the OUT terminal goes from inactive to active state. Additionally, a timeout detection circuit checks to ensure that the CD pin successfully begins charging to above VSS and subsequently drops back down to VSS, and if a timeout error is detected in either direction, it will similarly trigger the OUT pin to become active. See Figure 8 for details on CD and OUT pin behavior during an overvoltage event.

Feature Description (continued)

For an NCH Open Drain Active Low configuration, the OUT pin pulls down to VSS when active (OV present) and is high impedance when inactive (no OV).

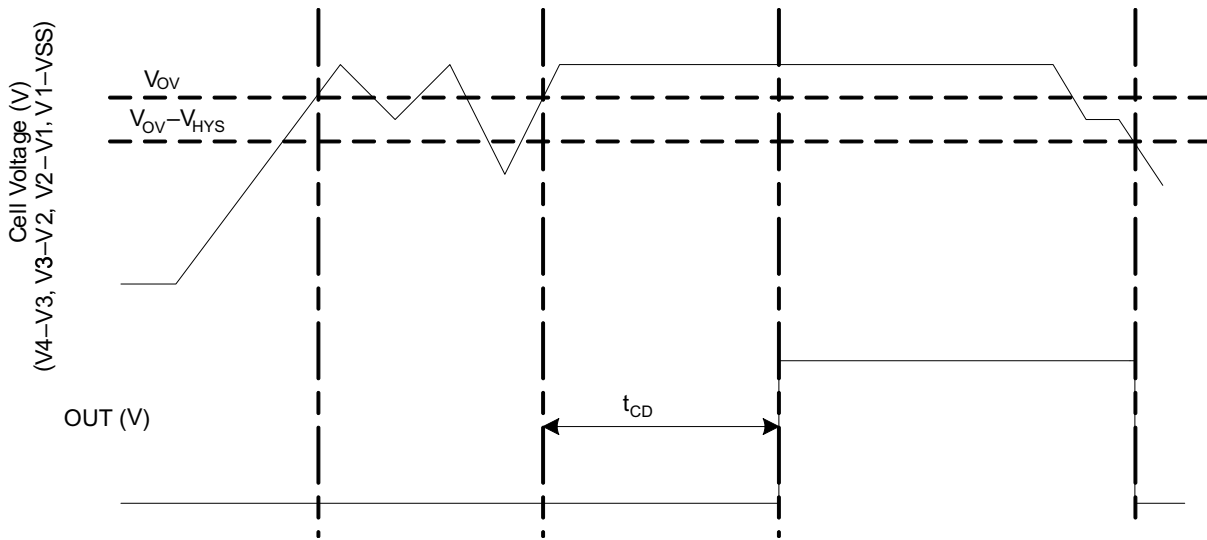

Figure 7. Timing for Overvoltage Sensing (OUT Pin Is Active High)

Figure 8 shows the behavior of CD pin during an OV sequence.

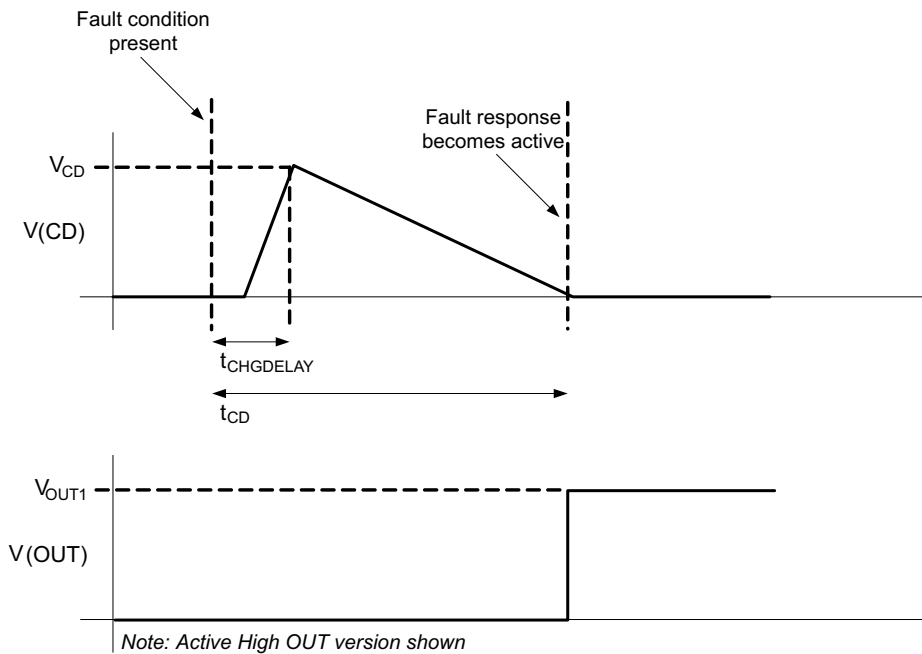

Figure 8. CD Pin Mechanism (OUT Pin Is Active High)

NOTE

In the case of an Open Drain Active Low version, the V_{OUT} signal will be high and transition to low state when the voltage on the V_{CD} capacitor discharges to the set level based on the t_{CD} timer.

Feature Description (continued)

8.3.1 Pin Details

8.3.1.1 Input Sense Voltage, V_x

These inputs sense each battery cell voltage. A series resistor and a capacitor across the cell for each input is required for noise filtering and stable voltage monitoring.

8.3.1.2 Output Drive, OUT

This terminal serves as the fault signal output, and may be ordered in either Active High or Open Drain Active Low options.

8.3.1.3 Supply Input, VDD

This terminal is the unregulated input power source for the IC. A series resistor is connected to limit the current, and a capacitor is connected to ground for noise filtering.

8.3.1.4 External Delay Capacitor, CD

This terminal is connected to an external capacitor that sets the delay timer during an overvoltage fault event.

The CD pin includes a timeout detection circuit to ensure that the output drives active even with a shorted or open capacitor during an overvoltage event.

The capacitor connected on the CD pin rapidly charges to a voltage if any one of the cell inputs exceeds the OV threshold. Then the delay circuit gradually discharges the capacitor on the CD pin. Once this capacitor discharges below a set voltage, the OUT transitions from an inactive to active state.

To calculate the delay, use the following equation:

$$t_{CD} \text{ (sec)} = K \times C_{CD} \text{ (\mu F)}, \text{ where } K = 10 \text{ to } 20 \text{ range.} \quad (1)$$

Example: If $C_{CD} = 0.1 \mu\text{F}$ (typical), then the delay timer range is

$$t_{CD} \text{ (s)} = 10 \times 0.1 = 1 \text{ s (Minimum)}$$

$$t_{CD} \text{ (s)} = 20 \times 0.1 = 2 \text{ s (Maximum)}$$

NOTE

The tolerance on the capacitor used for C_{CD} increases the range of the t_{CD} timer.

8.4 Device Functional Modes

8.4.1 NORMAL Mode

When all of the cell voltages are below the overvoltage threshold, V_{OV} , the device operates in NORMAL mode. The device monitors the differential cell voltages connected across ($V1-VSS$), ($V2-V1$), ($V3-V2$), and ($V4-V3$). The OUT pin is inactive, and is low if configured active high, or, if configured active low, is an open drain being externally pulled up.

8.4.2 OVERVOLTAGE Mode

OVERVOLTAGE mode is detected if any of the cell voltage exceeds the overvoltage threshold, V_{OV} for configured OV delay time. The OUT pin is activated after a delay time set by the capacitance in the CD pin. The OUT pin will either pull high internally, if configured as active high, or will be pulled low internally if configured as active low. An external FET is then turned on, shorting the fuse to ground, which allows the battery and/or charger power to blow the fuse. When all of the cell voltages fall below the ($V_{OV}-V_{HYS}$), the device returns to NORMAL mode.

8.4.3 Customer Test Mode

It is possible to reduce test time for checking the overvoltage function by simply shorting the external CD capacitor to VSS . In this case, the OV delay would be reduced to the $t_{(CD_GND)}$ value, which has a maximum of 170 ms.

Device Functional Modes (continued)

Figure 9 shows the timing for the Customer Test Mode.

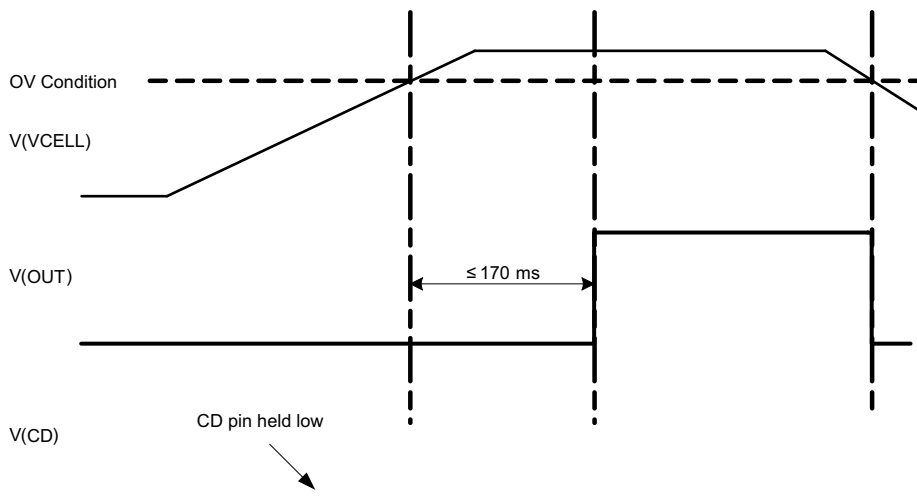

Figure 9. Timing for Customer Test Mode

Figure 10 shows the measurement for current consumption of the product for both VDD and Vx.

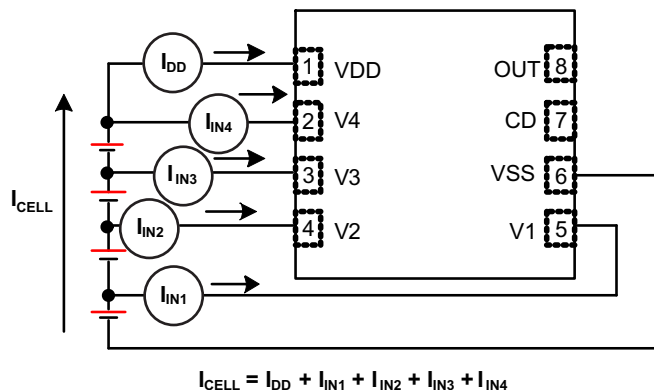

Figure 10. Configuration for IC Current Consumption Test

9 Application and Implementation

NOTE

Information in the following applications sections is not part of the TI component specification, and TI does not warrant its accuracy or completeness. TI's customers are responsible for determining suitability of components for their purposes. Customers should validate and test their design implementation to confirm system functionality.

9.1 Application Information

The bq2947 devices are a family of second-level protectors used for overvoltage protection of the battery pack in the application. The device, when configuring the OUT pin with active high, drives a NMOS FET that connects the fuse to ground in the event of a fault condition. This provides a shorted path to use the battery and/or charger power to blow the fuse and cut the power path. The OUT pin, when configured as active low, can be used to drive a PMOS FET to connect the fuse to ground instead.

9.2 Typical Applications

9.2.1 Application Configuration for Active High

Figure 11 shows the recommended reference design components.

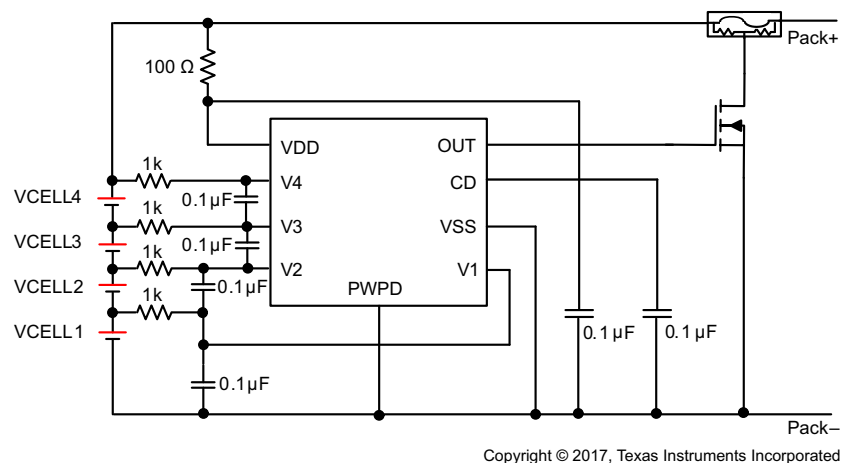

Figure 11. Application Configuration for Active High

9.2.1.1 Design Requirements

NOTE

In the case of an Open Drain Active Low configuration, an external pull-up resistor is required on the OUT terminal.

Changes to the ranges stated in Table 1 will impact the accuracy of the cell measurements.

Table 1. Parameters

PARAMETER	EXTERNAL COMPONENT	MIN	NOM	MAX	UNIT
Voltage monitor filter resistance	R_{IN}	900	1000	4700	Ω
Voltage monitor filter capacitance	C_{IN}	0.01	0.1	1.0	μF
Supply voltage filter resistance	R_{VD}	100		1000	Ω
Supply voltage filter capacitance	C_{VD}		0.1	1.0	μF
CD external delay capacitance	C_{CD}		0.1	1.0	μF

NOTE

The device is calibrated using an R_{IN} value = 1 k Ω . Using a value other than this recommended value changes the accuracy of the cell voltage measurements and V_{OV} trigger level.

9.2.1.2 Detailed Design Procedure

1. Determine the number of cell in series.

The device supports 2-S to 4-S cell configuration. For 2S and 3S, the top unused pin(s) should be shorted as shown in Figure 12 and Figure 13.

2. Determine the overvoltage protection delay.

Follow the calculation example described in CD pin description. Select the right capacitor to connect to the CD pin.

3. Follow the application schematic to connect the device. If the OUT pin is configured to open drain, an external pull up resistor should be used.

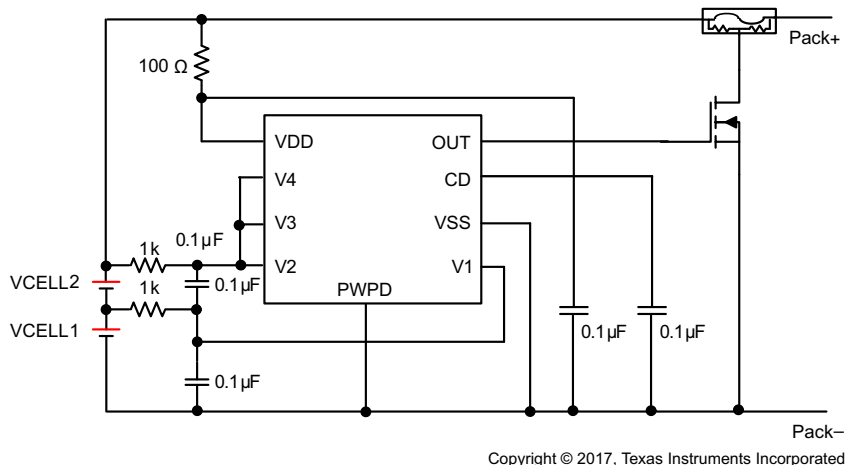

Figure 12. 2-Series Cell Configuration

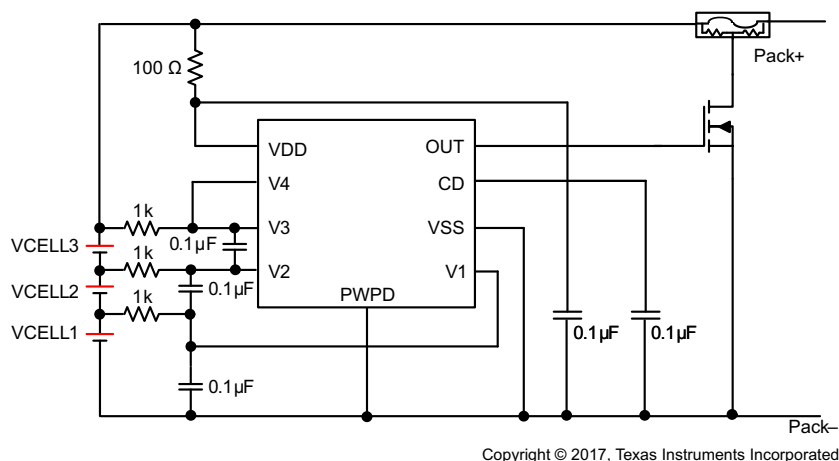

Figure 13. 3-Series Cell Configuration

9.2.1.3 Application Curves

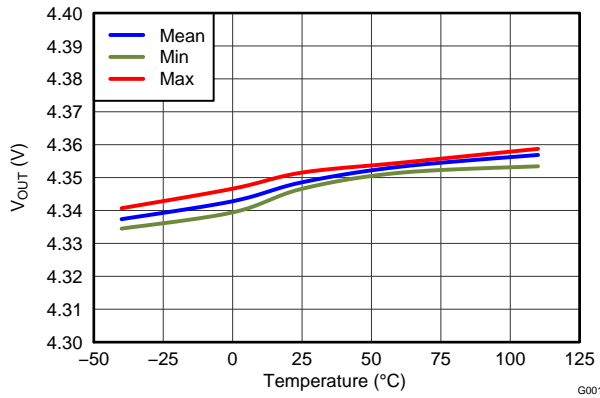

Figure 14. Overtolerance Threshold (OVT) vs. Temperature

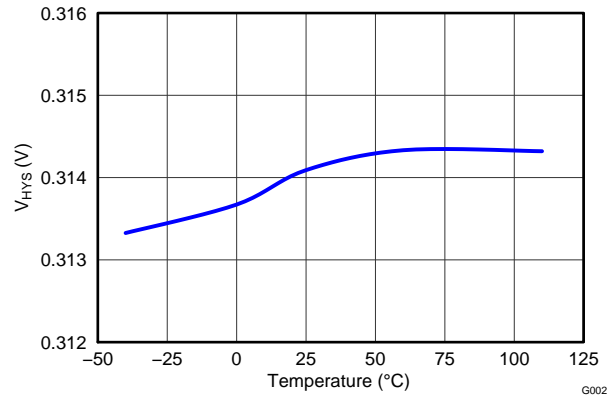

Figure 15. Hysteresis V_{HYS} vs. Temperature

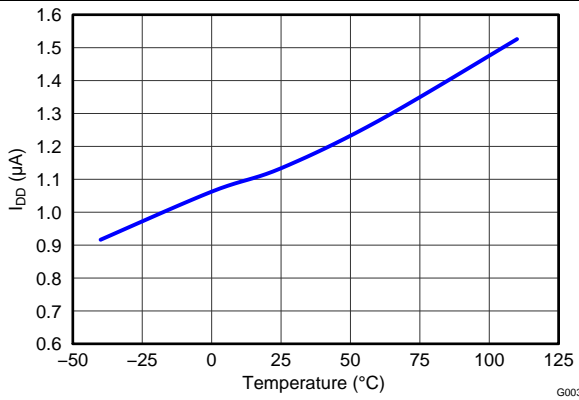

Figure 16. I_{DD} Current Consumption vs. Temperature at V_{DD} = 16 V

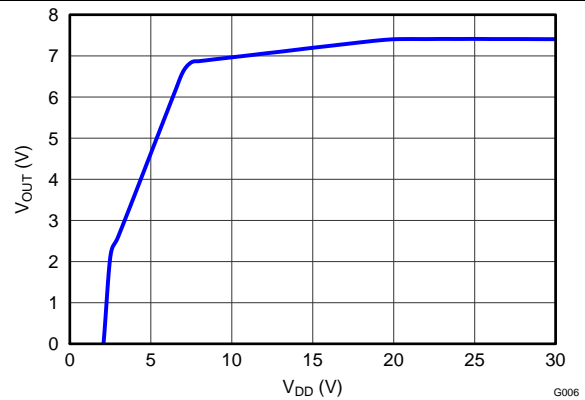

Figure 17. V_{OUT} vs. V_{DD}

10 Power Supply Recommendations

The maximum power of this device is 20 V on V_{DD} .

11 Layout

11.1 Layout Guidelines

1. Ensure the RC filters for the V_x pins and V_{DD} pin are placed as close as possible to the target terminal, reducing the tracing loop area.
2. The capacitor for CD should be placed close to the IC terminals.
3. Ensure the trace connecting the fuse to the gate, source of the NFET to the Pack- is sufficient to withstand the current during fuse blown event.

11.2 Layout Example

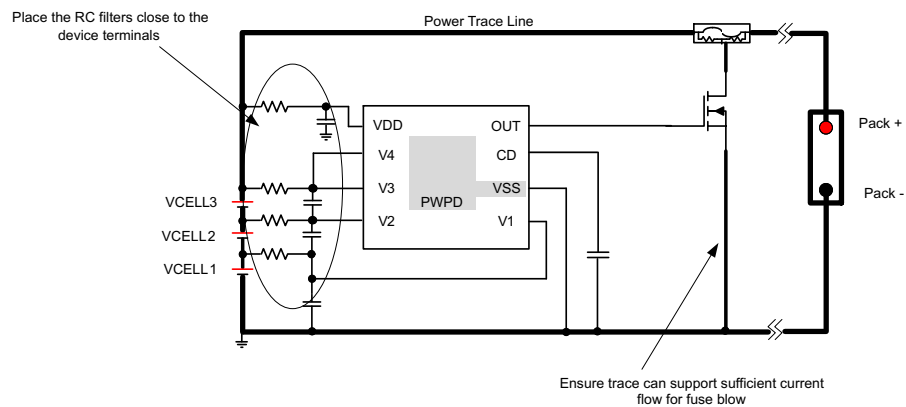

Figure 18. Layout Example

12 Device and Documentation Support

12.1 Documentation Support

12.1.1 Related Documentation

For related documentation, see [bq2945xy and bq2947xy Cascade Voltage Monitoring \(SLUA662\)](#).

12.2 Receiving Notification of Documentation Updates

To receive notification of documentation updates, navigate to the device product folder on [ti.com](#). In the upper right corner, click on *Alert me* to register and receive a weekly digest of any product information that has changed. For change details, review the revision history included in any revised document.

12.3 Community Resources

The following links connect to TI community resources. Linked contents are provided "AS IS" by the respective contributors. They do not constitute TI specifications and do not necessarily reflect TI's views; see TI's [Terms of Use](#).

TI E2E™ Online Community *TI's Engineer-to-Engineer (E2E) Community*. Created to foster collaboration among engineers. At [e2e.ti.com](#), you can ask questions, share knowledge, explore ideas and help solve problems with fellow engineers.

Design Support *TI's Design Support* Quickly find helpful E2E forums along with design support tools and contact information for technical support.

12.4 Trademarks

PowerPAD, E2E are trademarks of Texas Instruments.
All other trademarks are the property of their respective owners.

12.5 Electrostatic Discharge Caution



This integrated circuit can be damaged by ESD. Texas Instruments recommends that all integrated circuits be handled with appropriate precautions. Failure to observe proper handling and installation procedures can cause damage.

ESD damage can range from subtle performance degradation to complete device failure. Precision integrated circuits may be more susceptible to damage because very small parametric changes could cause the device not to meet its published specifications.

12.6 Glossary

[SLYZ022](#) — *TI Glossary*.

This glossary lists and explains terms, acronyms, and definitions.

13 Mechanical, Packaging, and Orderable Information

The following pages include mechanical, packaging, and orderable information. This information is the most current data available for the designated devices. This data is subject to change without notice and revision of this document. For browser-based versions of this data sheet, refer to the left-hand navigation.



DSG0008B

PACKAGE OUTLINE

WSO - 0.8 mm max height

PLASTIC SMALL OUTLINE - NO LEAD

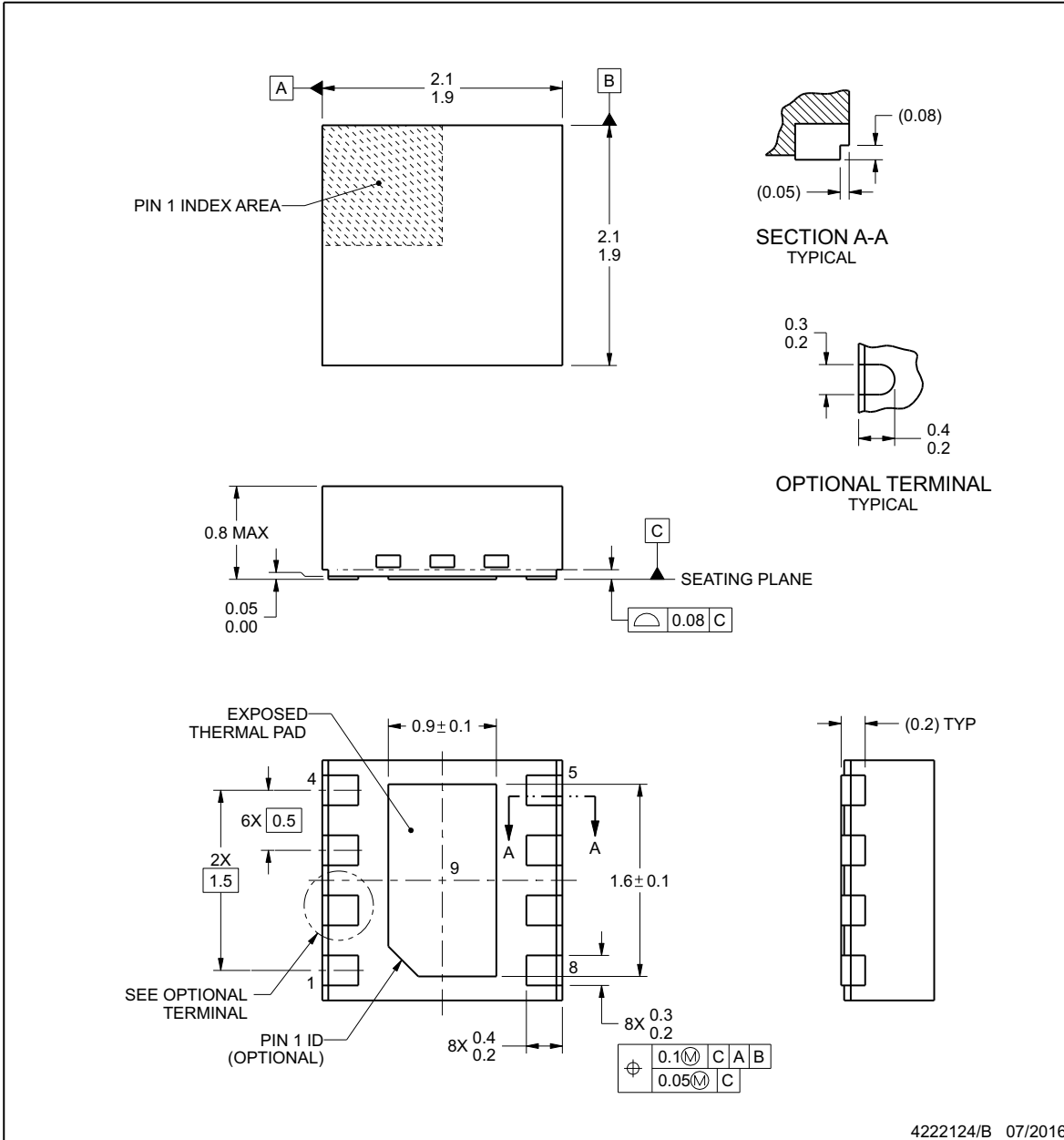

4222124/B 07/2016

NOTES:

1. All linear dimensions are in millimeters. Any dimensions in parenthesis are for reference only. Dimensioning and tolerancing per ASME Y14.5M.
2. This drawing is subject to change without notice.
3. The package thermal pad must be soldered to the printed circuit board for thermal and mechanical performance.

EXAMPLE BOARD LAYOUT

DSG0008B

WSON - 0.8 mm max height

PLASTIC SMALL OUTLINE - NO LEAD

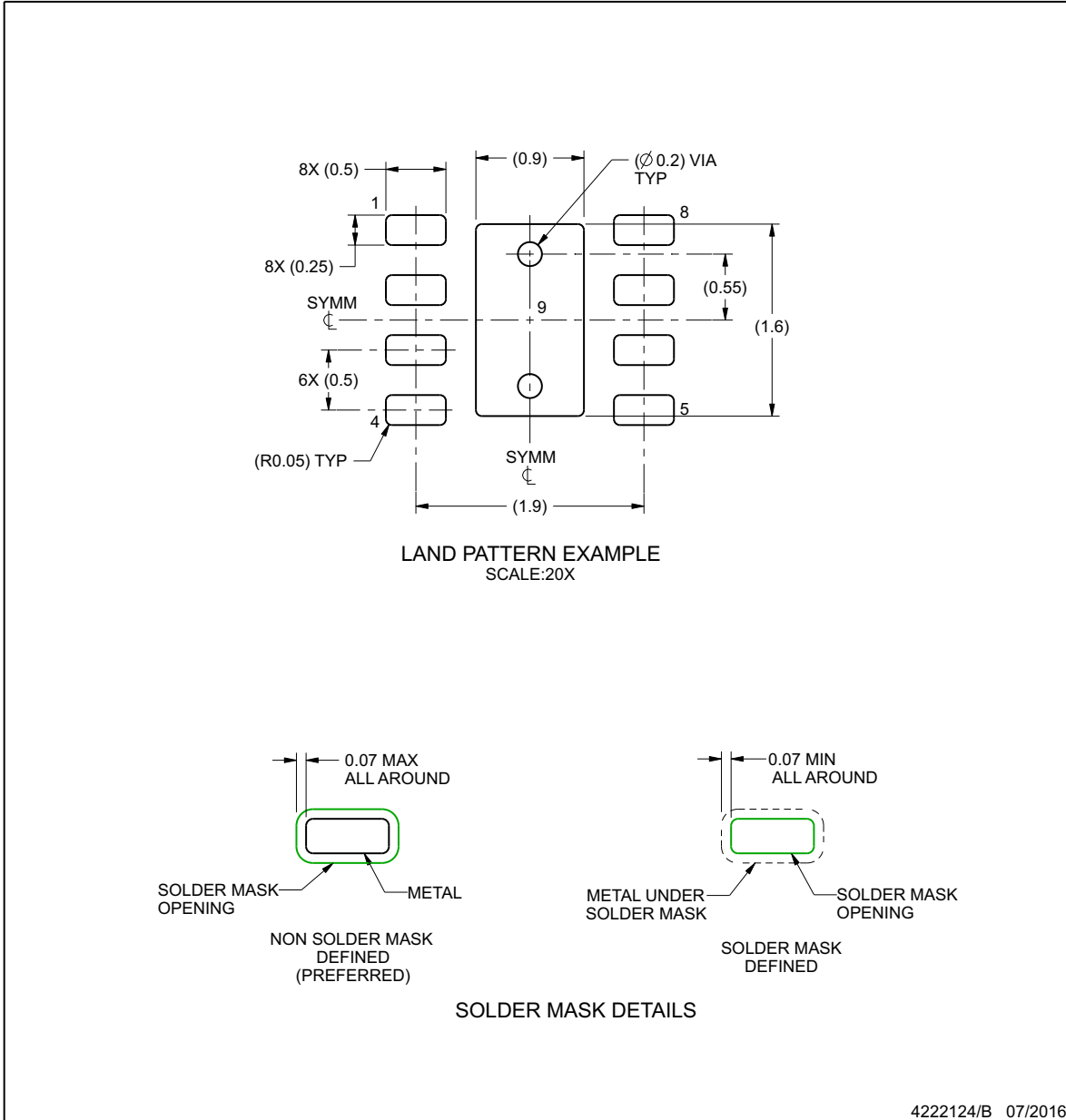

NOTES: (continued)

- This package is designed to be soldered to a thermal pad on the board. For more information, see Texas Instruments literature number SLUA271 (www.ti.com/lit/slua271).
- Vias are optional depending on application, refer to device data sheet. If any vias are implemented, refer to their locations shown on this view. It is recommended that vias under paste be filled, plugged or tented.

EXAMPLE STENCIL DESIGN

DSG0008B

WSON - 0.8 mm max height

PLASTIC SMALL OUTLINE - NO LEAD

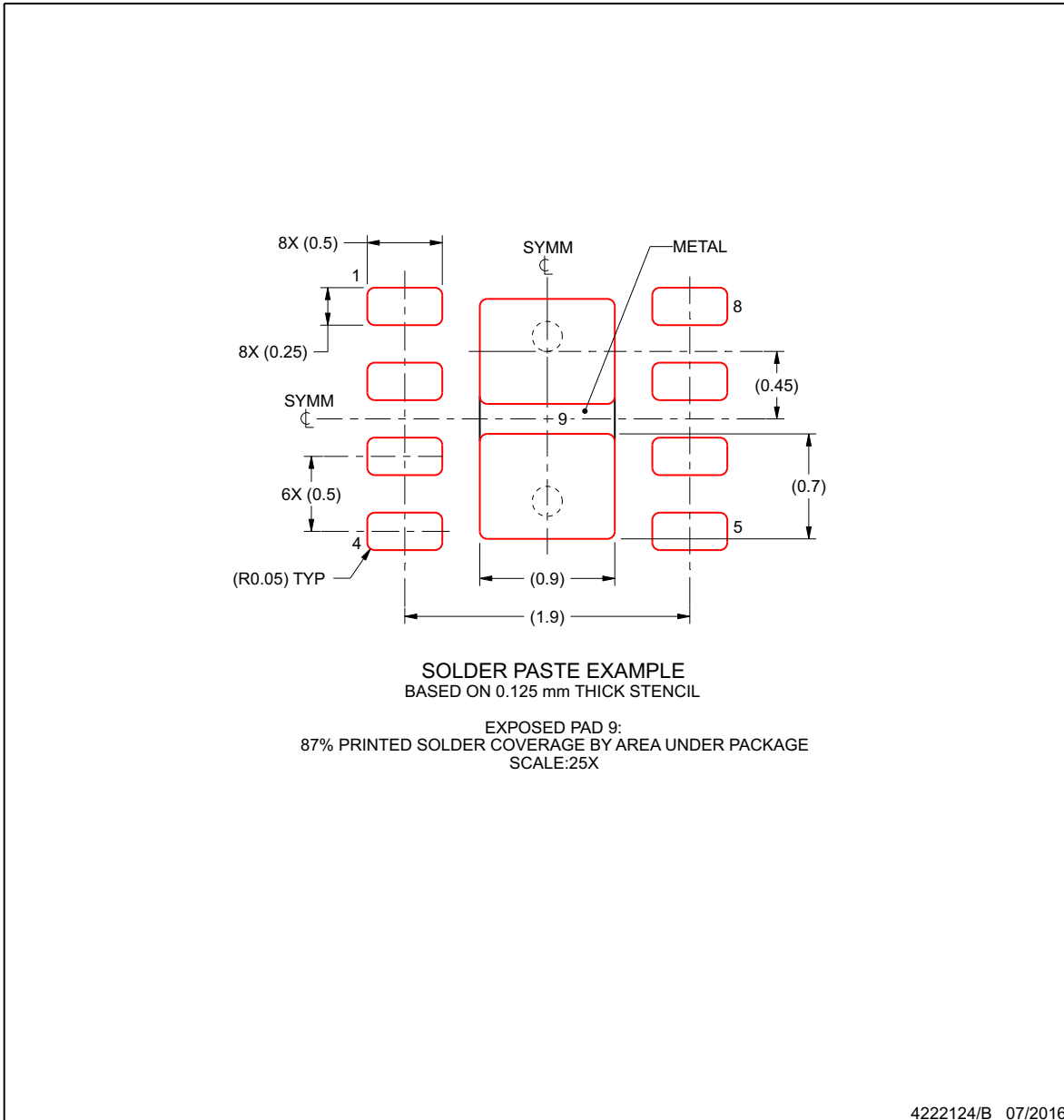

NOTES: (continued)

6. Laser cutting apertures with trapezoidal walls and rounded corners may offer better paste release. IPC-7525 may have alternate design recommendations.

PACKAGING INFORMATION

Orderable Device	Status (1)	Package Type	Package Drawing	Pins	Package Qty	Eco Plan (2)	Lead/Ball Finish (6)	MSL Peak Temp (3)	Op Temp (°C)	Device Marking (4/5)	Samples
BQ294700DSGR	ACTIVE	WSO	DSG	8	3000	Green (RoHS & no Sb/Br)	CU NIPDAU	Level-2-260C-1 YEAR	-40 to 85	700	Samples
BQ294700DSGT	ACTIVE	WSO	DSG	8	250	Green (RoHS & no Sb/Br)	CU NIPDAU	Level-2-260C-1 YEAR	-40 to 85	700	Samples
BQ294701DSGR	ACTIVE	WSO	DSG	8	3000	Green (RoHS & no Sb/Br)	CU NIPDAU	Level-2-260C-1 YEAR	-40 to 85	701	Samples
BQ294701DSGT	ACTIVE	WSO	DSG	8	250	Green (RoHS & no Sb/Br)	CU NIPDAU	Level-2-260C-1 YEAR	-40 to 85	701	Samples
BQ294702DSGR	ACTIVE	WSO	DSG	8	3000	Green (RoHS & no Sb/Br)	CU NIPDAU	Level-2-260C-1 YEAR	-40 to 85	702	Samples
BQ294702DSGT	ACTIVE	WSO	DSG	8	250	Green (RoHS & no Sb/Br)	CU NIPDAU	Level-2-260C-1 YEAR	-40 to 85	702	Samples
BQ294703DSGR	ACTIVE	WSO	DSG	8	3000	Green (RoHS & no Sb/Br)	CU NIPDAU	Level-2-260C-1 YEAR	-40 to 85	703	Samples
BQ294703DSGT	ACTIVE	WSO	DSG	8	250	Green (RoHS & no Sb/Br)	CU NIPDAU	Level-2-260C-1 YEAR	-40 to 85	703	Samples
BQ294704DSGR	ACTIVE	WSO	DSG	8	3000	Green (RoHS & no Sb/Br)	CU NIPDAU	Level-2-260C-1 YEAR	-40 to 85	704	Samples
BQ294704DSGT	ACTIVE	WSO	DSG	8	250	Green (RoHS & no Sb/Br)	CU NIPDAU	Level-2-260C-1 YEAR	-40 to 85	704	Samples
BQ294705DSGR	ACTIVE	WSO	DSG	8	3000	Green (RoHS & no Sb/Br)	CU NIPDAU	Level-2-260C-1 YEAR	-40 to 85	705	Samples
BQ294705DSGT	ACTIVE	WSO	DSG	8	250	Green (RoHS & no Sb/Br)	CU NIPDAU	Level-2-260C-1 YEAR	-40 to 85	705	Samples
BQ294706DSGR	ACTIVE	WSO	DSG	8	3000	Green (RoHS & no Sb/Br)	CU NIPDAU	Level-2-260C-1 YEAR	-40 to 85	706	Samples
BQ294706DSGT	ACTIVE	WSO	DSG	8	250	Green (RoHS & no Sb/Br)	CU NIPDAU	Level-2-260C-1 YEAR	-40 to 85	706	Samples
BQ294707DSGR	ACTIVE	WSO	DSG	8	3000	Green (RoHS & no Sb/Br)	CU NIPDAU	Level-2-260C-1 YEAR	-40 to 85	707	Samples
BQ294707DSGT	ACTIVE	WSO	DSG	8	250	Green (RoHS & no Sb/Br)	CU NIPDAU	Level-2-260C-1 YEAR	-40 to 85	707	Samples
BQ294708DSGR	ACTIVE	WSO	DSG	8	3000	Green (RoHS & no Sb/Br)	CU NIPDAU Call TI	Level-2-260C-1 YEAR	-40 to 85	708	Samples

Orderable Device	Status (1)	Package Type	Package Drawing	Pins	Package Qty	Eco Plan (2)	Lead/Ball Finish (6)	MSL Peak Temp (3)	Op Temp (°C)	Device Marking (4/5)	Samples
BQ294708DSGT	ACTIVE	WSO	DSG	8	250	Green (RoHS & no Sb/Br)	CU NIPDAU Call TI	Level-2-260C-1 YEAR	-40 to 85	708	Samples
BQ294711DSGR	ACTIVE	WSO	DSG	8	3000	Green (RoHS & no Sb/Br)	CU NIPDAU	Level-2-260C-1 YEAR	-40 to 85	711	Samples
BQ294711DSGT	ACTIVE	WSO	DSG	8	250	Green (RoHS & no Sb/Br)	CU NIPDAU	Level-2-260C-1 YEAR	-40 to 85	711	Samples

(1) The marketing status values are defined as follows:

ACTIVE: Product device recommended for new designs.

LIFEBUY: TI has announced that the device will be discontinued, and a lifetime-buy period is in effect.

NRND: Not recommended for new designs. Device is in production to support existing customers, but TI does not recommend using this part in a new design.

PREVIEW: Device has been announced but is not in production. Samples may or may not be available.

OBSELETE: TI has discontinued the production of the device.

(2) **RoHS:** TI defines "RoHS" to mean semiconductor products that are compliant with the current EU RoHS requirements for all 10 RoHS substances, including the requirement that RoHS substance do not exceed 0.1% by weight in homogeneous materials. Where designed to be soldered at high temperatures, "RoHS" products are suitable for use in specified lead-free processes. TI may reference these types of products as "Pb-Free".

RoHS Exempt: TI defines "RoHS Exempt" to mean products that contain lead but are compliant with EU RoHS pursuant to a specific EU RoHS exemption.

Green: TI defines "Green" to mean the content of Chlorine (Cl) and Bromine (Br) based flame retardants meet JS709B low halogen requirements of <=1000ppm threshold. Antimony trioxide based flame retardants must also meet the <=1000ppm threshold requirement.

(3) MSL, Peak Temp. - The Moisture Sensitivity Level rating according to the JEDEC industry standard classifications, and peak solder temperature.

(4) There may be additional marking, which relates to the logo, the lot trace code information, or the environmental category on the device.

(5) Multiple Device Markings will be inside parentheses. Only one Device Marking contained in parentheses and separated by a "-" will appear on a device. If a line is indented then it is a continuation of the previous line and the two combined represent the entire Device Marking for that device.

(6) Lead/Ball Finish - Orderable Devices may have multiple material finish options. Finish options are separated by a vertical ruled line. Lead/Ball Finish values may wrap to two lines if the finish value exceeds the maximum column width.

Important Information and Disclaimer:The information provided on this page represents TI's knowledge and belief as of the date that it is provided. TI bases its knowledge and belief on information provided by third parties, and makes no representation or warranty as to the accuracy of such information. Efforts are underway to better integrate information from third parties. TI has taken and continues to take reasonable steps to provide representative and accurate information but may not have conducted destructive testing or chemical analysis on incoming materials and chemicals. TI and TI suppliers consider certain information to be proprietary, and thus CAS numbers and other limited information may not be available for release.

In no event shall TI's liability arising out of such information exceed the total purchase price of the TI part(s) at issue in this document sold by TI to Customer on an annual basis.

TAPE AND REEL INFORMATION



QUADRANT ASSIGNMENTS FOR PIN 1 ORIENTATION IN TAPE



*All dimensions are nominal

Device	Package Type	Package Drawing	Pins	SPQ	Reel Diameter (mm)	Reel Width W1 (mm)	A0 (mm)	B0 (mm)	K0 (mm)	P1 (mm)	W (mm)	Pin1 Quadrant
BQ294700DSGR	WSON	DSG	8	3000	180.0	8.4	2.3	2.3	1.15	4.0	8.0	Q2
BQ294700DSGT	WSON	DSG	8	250	180.0	8.4	2.3	2.3	1.15	4.0	8.0	Q2
BQ294701DSGR	WSON	DSG	8	3000	180.0	8.4	2.3	2.3	1.15	4.0	8.0	Q2
BQ294701DSGT	WSON	DSG	8	250	180.0	8.4	2.3	2.3	1.15	4.0	8.0	Q2
BQ294702DSGR	WSON	DSG	8	3000	180.0	8.4	2.3	2.3	1.15	4.0	8.0	Q2
BQ294702DSGT	WSON	DSG	8	250	180.0	8.4	2.3	2.3	1.15	4.0	8.0	Q2
BQ294703DSGR	WSON	DSG	8	3000	180.0	8.4	2.3	2.3	1.15	4.0	8.0	Q2
BQ294703DSGT	WSON	DSG	8	250	180.0	8.4	2.3	2.3	1.15	4.0	8.0	Q2
BQ294704DSGR	WSON	DSG	8	3000	180.0	8.4	2.3	2.3	1.15	4.0	8.0	Q2
BQ294704DSGT	WSON	DSG	8	250	180.0	8.4	2.3	2.3	1.15	4.0	8.0	Q2
BQ294705DSGR	WSON	DSG	8	3000	180.0	8.4	2.3	2.3	1.15	4.0	8.0	Q2
BQ294705DSGT	WSON	DSG	8	250	180.0	8.4	2.3	2.3	1.15	4.0	8.0	Q2
BQ294706DSGR	WSON	DSG	8	3000	180.0	8.4	2.3	2.3	1.15	4.0	8.0	Q2
BQ294706DSGT	WSON	DSG	8	250	180.0	8.4	2.3	2.3	1.15	4.0	8.0	Q2
BQ294707DSGR	WSON	DSG	8	3000	180.0	8.4	2.3	2.3	1.15	4.0	8.0	Q2
BQ294707DSGT	WSON	DSG	8	250	180.0	8.4	2.3	2.3	1.15	4.0	8.0	Q2
BQ294708DSGR	WSON	DSG	8	3000	180.0	8.4	2.3	2.3	1.15	4.0	8.0	Q2
BQ294708DSGT	WSON	DSG	8	250	180.0	8.4	2.3	2.3	1.15	4.0	8.0	Q2

Device	Package Type	Package Drawing	Pins	SPQ	Reel Diameter (mm)	Reel Width W1 (mm)	A0 (mm)	B0 (mm)	K0 (mm)	P1 (mm)	W (mm)	Pin1 Quadrant
BQ294711DSGR	WSON	DSG	8	3000	180.0	8.4	2.3	2.3	1.15	4.0	8.0	Q2
BQ294711DSGT	WSON	DSG	8	250	180.0	8.4	2.3	2.3	1.15	4.0	8.0	Q2

TAPE AND REEL BOX DIMENSIONS

*All dimensions are nominal

Device	Package Type	Package Drawing	Pins	SPQ	Length (mm)	Width (mm)	Height (mm)
BQ294700DSGR	WSON	DSG	8	3000	210.0	185.0	35.0
BQ294700DSGT	WSON	DSG	8	250	210.0	185.0	35.0
BQ294701DSGR	WSON	DSG	8	3000	210.0	185.0	35.0
BQ294701DSGT	WSON	DSG	8	250	210.0	185.0	35.0
BQ294702DSGR	WSON	DSG	8	3000	210.0	185.0	35.0
BQ294702DSGT	WSON	DSG	8	250	210.0	185.0	35.0
BQ294703DSGR	WSON	DSG	8	3000	210.0	185.0	35.0
BQ294703DSGT	WSON	DSG	8	250	210.0	185.0	35.0
BQ294704DSGR	WSON	DSG	8	3000	210.0	185.0	35.0
BQ294704DSGT	WSON	DSG	8	250	210.0	185.0	35.0
BQ294705DSGR	WSON	DSG	8	3000	210.0	185.0	35.0
BQ294705DSGT	WSON	DSG	8	250	210.0	185.0	35.0
BQ294706DSGR	WSON	DSG	8	3000	210.0	185.0	35.0
BQ294706DSGT	WSON	DSG	8	250	210.0	185.0	35.0
BQ294707DSGR	WSON	DSG	8	3000	210.0	185.0	35.0

Device	Package Type	Package Drawing	Pins	SPQ	Length (mm)	Width (mm)	Height (mm)
BQ294707DSGT	WSON	DSG	8	250	210.0	185.0	35.0
BQ294708DSGR	WSON	DSG	8	3000	210.0	185.0	35.0
BQ294708DSGT	WSON	DSG	8	250	210.0	185.0	35.0
BQ294711DSGR	WSON	DSG	8	3000	210.0	185.0	35.0
BQ294711DSGT	WSON	DSG	8	250	210.0	185.0	35.0

GENERIC PACKAGE VIEW

DSG 8

WSON - 0.8 mm max height

2 x 2, 0.5 mm pitch

PLASTIC SMALL OUTLINE - NO LEAD

This image is a representation of the package family, actual package may vary.
Refer to the product data sheet for package details.



4224783/A

DSG0008A

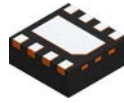

PACKAGE OUTLINE

WSON - 0.8 mm max height

PLASTIC SMALL OUTLINE - NO LEAD

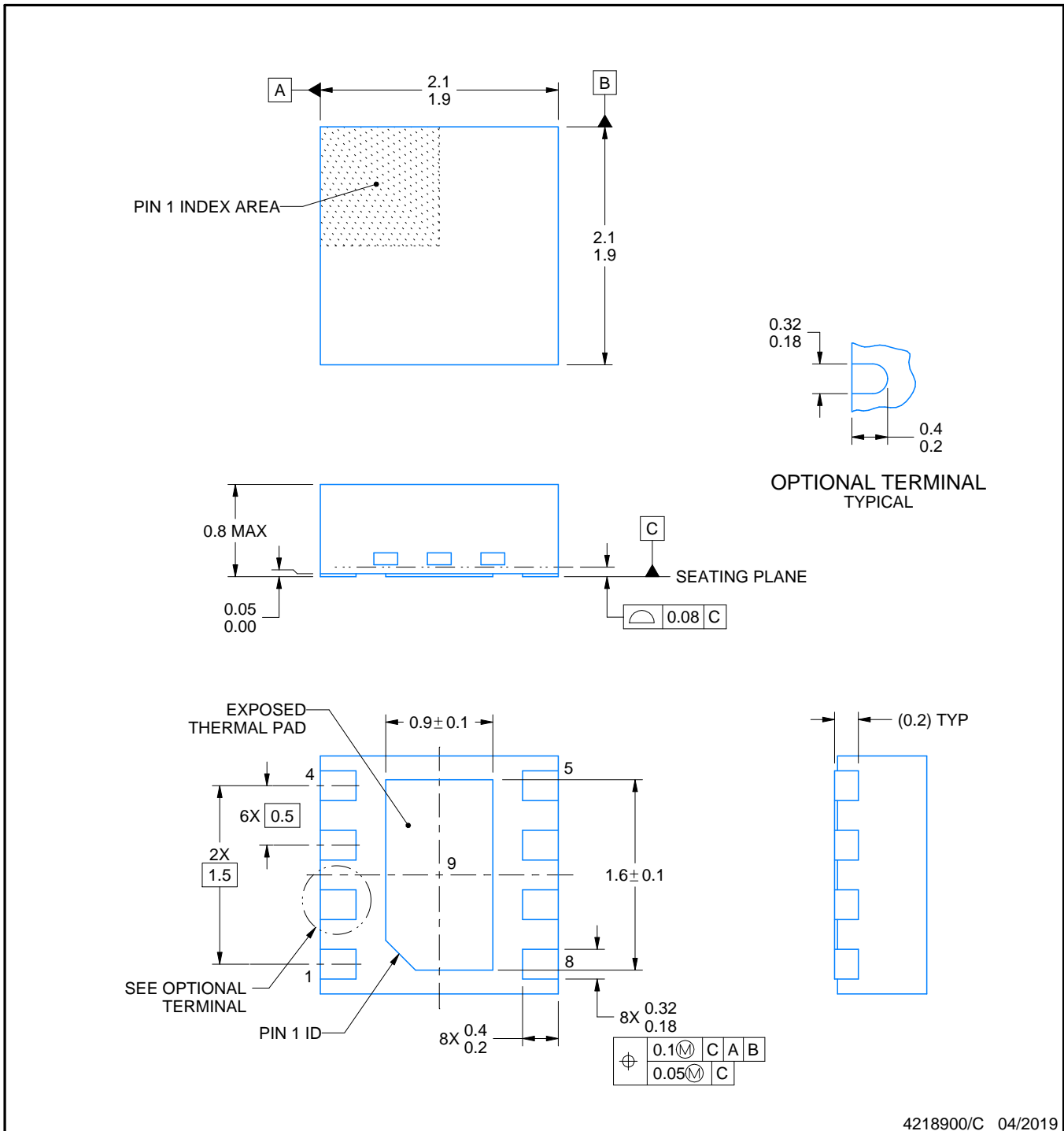

NOTES:

1. All linear dimensions are in millimeters. Any dimensions in parenthesis are for reference only. Dimensioning and tolerancing per ASME Y14.5M.
2. This drawing is subject to change without notice.
3. The package thermal pad must be soldered to the printed circuit board for thermal and mechanical performance.

EXAMPLE BOARD LAYOUT

DSG0008A

WSON - 0.8 mm max height

PLASTIC SMALL OUTLINE - NO LEAD

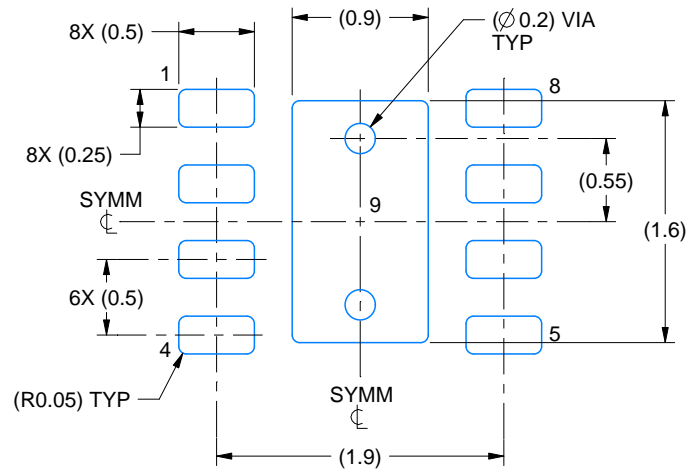

LAND PATTERN EXAMPLE
SCALE:20X

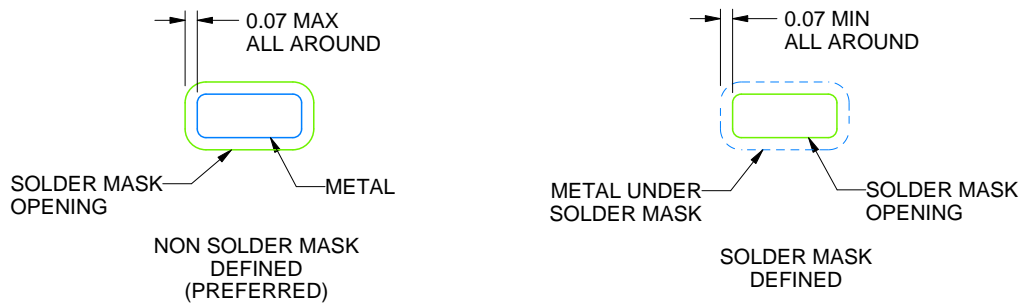

SOLDER MASK DETAILS

4218900/C 04/2019

NOTES: (continued)

4. This package is designed to be soldered to a thermal pad on the board. For more information, see Texas Instruments literature number SLUA271 (www.ti.com/lit/sluea271).
5. Vias are optional depending on application, refer to device data sheet. If any vias are implemented, refer to their locations shown on this view. It is recommended that vias under paste be filled, plugged or tented.

EXAMPLE STENCIL DESIGN

DSG0008A

WSON - 0.8 mm max height

PLASTIC SMALL OUTLINE - NO LEAD

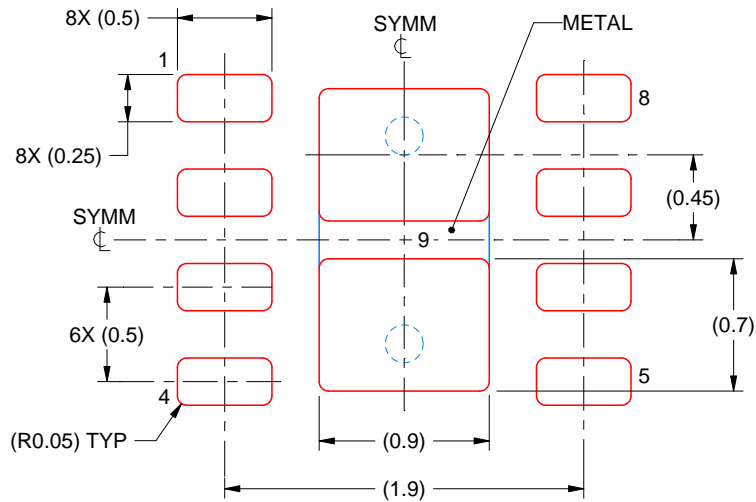

SOLDER PASTE EXAMPLE
BASED ON 0.125 mm THICK STENCIL

EXPOSED PAD 9:
87% PRINTED SOLDER COVERAGE BY AREA UNDER PACKAGE
SCALE:25X

4218900/C 04/2019

NOTES: (continued)

6. Laser cutting apertures with trapezoidal walls and rounded corners may offer better paste release. IPC-7525 may have alternate design recommendations.

IMPORTANT NOTICE AND DISCLAIMER

TI PROVIDES TECHNICAL AND RELIABILITY DATA (INCLUDING DATASHEETS), DESIGN RESOURCES (INCLUDING REFERENCE DESIGNS), APPLICATION OR OTHER DESIGN ADVICE, WEB TOOLS, SAFETY INFORMATION, AND OTHER RESOURCES "AS IS" AND WITH ALL FAULTS, AND DISCLAIMS ALL WARRANTIES, EXPRESS AND IMPLIED, INCLUDING WITHOUT LIMITATION ANY IMPLIED WARRANTIES OF MERCHANTABILITY, FITNESS FOR A PARTICULAR PURPOSE OR NON-INFRINGEMENT OF THIRD PARTY INTELLECTUAL PROPERTY RIGHTS.

These resources are intended for skilled developers designing with TI products. You are solely responsible for (1) selecting the appropriate TI products for your application, (2) designing, validating and testing your application, and (3) ensuring your application meets applicable standards, and any other safety, security, or other requirements. These resources are subject to change without notice. TI grants you permission to use these resources only for development of an application that uses the TI products described in the resource. Other reproduction and display of these resources is prohibited. No license is granted to any other TI intellectual property right or to any third party intellectual property right. TI disclaims responsibility for, and you will fully indemnify TI and its representatives against, any claims, damages, costs, losses, and liabilities arising out of your use of these resources.

TI's products are provided subject to TI's Terms of Sale (www.ti.com/legal/termsofsale.html) or other applicable terms available either on ti.com or provided in conjunction with such TI products. TI's provision of these resources does not expand or otherwise alter TI's applicable warranties or warranty disclaimers for TI products.

Mailing Address: Texas Instruments, Post Office Box 655303, Dallas, Texas 75265
Copyright © 2019, Texas Instruments Incorporated

Looking for pricing, stock, or lifecycle information?

Click below to explore more details on WIN SOURCE:

 [View BQ294700DSGR](#) on WIN SOURCE

 [Texas Instruments](#) Information

Optimize Your Supply Chain with WIN SOURCE Solutions

-  Global Sourcing Solution
-  Obsolete Management
-  Cost Control Management
-  Shortage Management
-  Alternative Solution
-  Excess Inventory Management