



**THE DATASHEET OF  
BQ294512DRVR**



## bq2945xx Overvoltage Protection For 2-Series and 3-Series Cell Li-Ion Batteries

### 1 Features

- 2-Series and 3-Series Cell Overvoltage Monitor for Secondary Protection
- Fixed Programmable Delay Timer
- Fixed OVP Threshold
  - Available Range From 3.85 V to 4.6 V
- Fixed OVP Delay Option: 4 s or 6.5 s
- High-Accuracy Overvoltage Protection:  $\pm 10$  mV
- Low Power Consumption  $I_{CC} \approx 1$   $\mu$ A ( $V_{CELL(ALL)} < V_{PROTECT}$ )
- Low Leakage Current per Cell Input  $< 100$  nA
- Small Package Footprint
  - 6-Pin SON

### 2 Applications

- Second-Level Protection in Li-Ion Battery Packs in:
  - Tablets
  - Slates
  - Power Tools
  - Notebook Computers
  - Portable Equipment and Instrumentation

### 3 Description

The bq2945xx family of products is a secondary-level voltage monitor and protector for Li-Ion battery pack systems. Each cell is monitored independently for an overvoltage condition. Based on the configuration, an output is triggered after a fixed delay if any of the two or three cells has an overvoltage condition. This output is triggered into a high state after an overvoltage condition satisfies the specified delay timer.

#### Device Information<sup>(1)</sup>

| PART NUMBER | PACKAGE | BODY SIZE (NOM)   |
|-------------|---------|-------------------|
| bq2945xx    | SON (6) | 2.00 mm x 2.00 mm |

(1) For all available packages, see the orderable addendum at the end of the data sheet.

#### Simplified Schematic

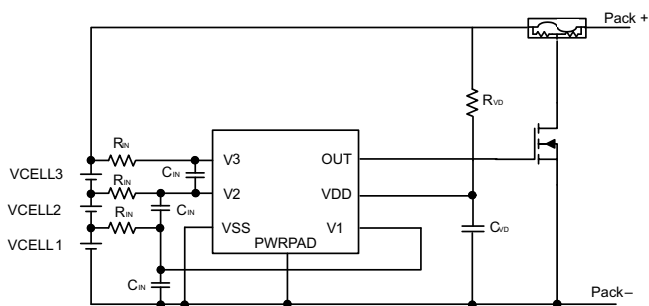

Copyright © 2017, Texas Instruments Incorporated



## Table of Contents

|  |          |  |           |
|--|----------|--|-----------|
| <b>1 Features</b> .....                        | <b>1</b> | <b>9 Application and Implementation</b> .....        | <b>11</b> |
| <b>2 Applications</b> .....                    | <b>1</b> | 9.1 Application Information.....                     | 11        |
| <b>3 Description</b> .....                     | <b>1</b> | 9.2 Typical Application .....                        | 11        |
| <b>4 Revision History</b> .....                | <b>2</b> | 9.3 System Examples .....                            | 12        |
| <b>5 Device Comparison Table</b> .....         | <b>4</b> | <b>10 Power Supply Recommendations</b> .....         | <b>13</b> |
| <b>6 Pin Configuration and Functions</b> ..... | <b>4</b> | <b>11 Layout</b> .....                               | <b>13</b> |
| <b>7 Specifications</b> .....                  | <b>5</b> | 11.1 Layout Guidelines .....                         | 13        |
| 7.1 Absolute Maximum Ratings .....             | 5        | 11.2 Layout Example .....                            | 13        |
| 7.2 ESD Ratings.....                           | 5        | <b>12 Device and Documentation Support</b> .....     | <b>14</b> |
| 7.3 Recommended Operating Conditions.....      | 5        | 12.1 Device Support.....                             | 14        |
| 7.4 Thermal Information .....                  | 5        | 12.2 Related Links .....                             | 14        |
| 7.5 Electrical Characteristics.....            | 6        | 12.3 Receiving Notification of Documentation Updates | 14        |
| 7.6 Typical Characteristics .....              | 7        | 12.4 Community Resources.....                        | 14        |
| <b>8 Detailed Description</b> .....            | <b>8</b> | 12.5 Trademarks .....                                | 14        |
| 8.1 Overview .....                             | 8        | 12.6 Electrostatic Discharge Caution.....            | 14        |
| 8.2 Functional Block Diagram .....             | 8        | 12.7 Glossary .....                                  | 15        |
| 8.3 Feature Description.....                   | 8        | <b>13 Mechanical, Packaging, and Orderable</b>       |           |
| 8.4 Device Functional Modes.....               | 9        | <b>Information</b> .....                             | <b>15</b> |

## 4 Revision History

NOTE: Page numbers for previous revisions may differ from page numbers in the current version.

| Changes from Revision G (November 2017) to Revision H                               | Page |
|---|------|
| • Added the bq294506 device to the <a href="#">Device Comparison Table</a> .....    | 4    |
| • Added the bq294506 device to the <a href="#">Electrical Characteristics</a> ..... | 6    |

| Changes from Revision F (June 2017) to Revision G              | Page |
|--|------|
| • Changed the <a href="#">Device Comparison Table</a> .....    | 4    |
| • Changed the <a href="#">Electrical Characteristics</a> ..... | 6    |

| Changes from Revision E (December 2016) to Revision F                       | Page |
|---|------|
| • Added bq294533 to the <a href="#">Device Comparison Table</a> table ..... | 4    |
| • Added the bq294592 device to Production Data.....                         | 4    |
| • Added the bq294533 VOV <a href="#">Electrical Characteristics</a> .....   | 6    |

| Changes from Revision D (July 2015) to Revision E  | Page |
|--|------|
| • Changed RIN range values in <i>Design Requirements</i> section from: MIN: 900, MAX: 1100 to: MIN: 100, MAX: 4700 ..... | 11   |
| • Changed CIN range values <i>Design Requirements</i> section from: MIN: 0.01, MAX: 0.1 to: MIN: 0.1, MAX: 1 .....       | 11   |
| • Added <i>Receiving Notification of Documentation Updates</i> section .....   | 14   |

| Changes from Revision C (May 2012) to Revision D   | Page |
|--|------|
| • Added <i>ESD Ratings</i> table, <i>Feature Description</i> section, <i>Device Functional Modes</i> , <i>Application and Implementation</i> section, <i>Power Supply Recommendations</i> section, <i>Layout</i> section, <i>Device and Documentation Support</i> section, and <i>Mechanical, Packaging, and Orderable Information</i> section ..... | 1    |
| • Added Overvoltage to description .....   | 1    |

|   |   |
|---|---|
| • Changed bullets to consolidate feature item ..... | 1 |
| • Added Fixed OVP Delay Option to Features .....    | 1 |
| • Changed <i>Absolute Maximum Ratings</i> .....     | 5 |
| • Changed format of graphs .....                    | 7 |

---

|  |             |
|--|-------------|
| <b>Changes from Revision B (February 2012) to Revision C</b> | <b>Page</b> |
|--|-------------|

|  |    |
|--|----|
| • Added the bq294524 device to Production Data .....       | 4  |
| • Added the bq294532 device to Production Data .....       | 4  |
| • Changed Overvoltage Detection Hysteresis .....           | 6  |
| • Added Output Voltage Versus Output Current graphic ..... | 7  |
| • Changed Timing for Customer Test Mode figure .....       | 10 |

---

|  |             |
|--|-------------|
| <b>Changes from Revision A (November 2011) to Revision B</b> | <b>Page</b> |
|--|-------------|

|   |   |
|---|---|
| • Changed the bq294504 Device to Production Data .....                          | 1 |
| • Added the bq294512 Device .....   | 1 |
| • Added the bq294592 Device .....   | 1 |
| • Added a second I <sub>CC</sub> Test Condition .....                           | 6 |
| • Changed Fault Detection Delay Time in bq2945x4 Test Mode Specifications ..... | 6 |

---

|   |             |
|---|-------------|
| <b>Changes from Original (September 2011) to Revision A</b> | <b>Page</b> |
|---|-------------|

|  |   |
|--|---|
| • Added the bq294582 device to Production Data ..... | 4 |
|--|---|

## 5 Device Comparison Table

| T <sub>A</sub>  | PART NUMBER             | OVP (V) | DELAY TIME (s) |
|-----------------|-------------------------|---------|----------------|
| -40°C to +110°C | bq294502                | 4.35    | 4              |
|                 | bq294504                | 4.35    | 6.5            |
|                 | bq294506 <sup>(1)</sup> | 4.38    | 4              |
|                 | bq294512                | 4.4     | 4              |
|                 | bq294522                | 4.45    | 4              |
|                 | bq294524                | 4.45    | 6.5            |
|                 | bq294532                | 4.5     | 4              |
|                 | bq294533                | 4.5     | 6.5            |
|                 | bq294582                | 4.225   | 4              |
|                 | bq294592                | 4.3     | 4              |

(1) Advance Information. Contact TI for more information.

## 6 Pin Configuration and Functions

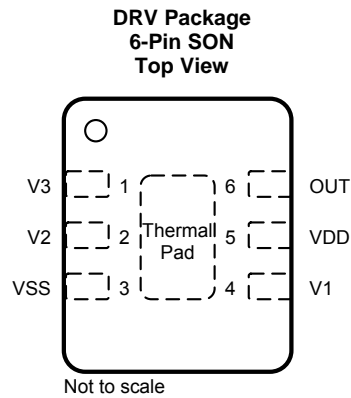

### Pin Functions

| NUMBER | NAME   | I/O               | DESCRIPTION  |
|--------|--------|-------------------|--|
| 1      | V3     | IA                | Sense input for positive voltage of the third cell from the bottom of the stack.               |
| 2      | V2     | IA                | Sense input for positive voltage of the second cell from the bottom of the stack.              |
| 3      | VSS    | P                 | Electrically connected to IC ground and negative terminal of the lowest cell in the stack.     |
| 4      | V1     | IA                | Sense input for positive voltage of the lowest cell in the stack.                              |
| 5      | VDD    | P                 | Power supply   |
| 6      | OUT    | OA <sup>(1)</sup> | Output drive for external N-channel FET.   |
| —      | PWRPAD | —                 | VSS pin to be connected to the PWRPAD on the printed-circuit-board (PCB) for proper operation. |

(1) IA = Input Analog, OA = Output Analog, P = Power Connection

## 7 Specifications

### 7.1 Absolute Maximum Ratings

over operating free-air temperature range (unless otherwise noted)<sup>(1)(2)</sup>

|   |                             | MIN                                     | MAX | UNIT |
|---|-----------------------------|---|-----|------|
| Supply voltage  | VDD–VSS                     | –0.3                                    | 30  | V    |
| Input voltage   | V1–VSS or V2–VSS or V3–VSS+ | –0.3                                    | 30  | V    |
|   | V3–V2 or V2–V1              | –0.3                                    | 8   | V    |
| Output voltage  | OUT–VSS                     | –0.3                                    | 30  | V    |
| Continuous total power dissipation, P <sub>TOT</sub>    |                             | See <a href="#">Thermal Information</a> |     |      |
| Lead temperature (soldering, 10 s), T <sub>SOLDER</sub> |                             |   | 300 | °C   |
| Storage temperature, T <sub>stg</sub>                   |                             | –65                                     | 150 | °C   |

- (1) Stresses beyond those listed under *Absolute Maximum Ratings* may cause permanent damage to the device. These are stress ratings only, which do not imply functional operation of the device at these or any other conditions beyond those indicated under *Recommended Operating Conditions*. Exposure to absolute-maximum-rated conditions for extended periods may affect device reliability.
- (2) See [Figure 8](#).

### 7.2 ESD Ratings

|  |  | VALUE | UNIT |
|--|--|-------|------|
| V <sub>(ESD)</sub> Electrostatic discharge | Human body model (HBM), per ANSI/ESDA/JEDEC JS-001 <sup>(1)</sup>              | ±2000 | V    |
|  | Charged device model (CDM), per JEDEC specification JESD22-C101 <sup>(2)</sup> | ±500  |      |

- (1) JEDEC document JEP155 states that 500-V HBM allows safe manufacturing with a standard ESD control process.
- (2) JEDEC document JEP157 states that 250-V CDM allows safe manufacturing with a standard ESD control process.

### 7.3 Recommended Operating Conditions

over operating free-air temperature range (unless otherwise noted)

|  |                          | MIN | MAX | UNIT |
|--|--------------------------|-----|-----|------|
| Supply voltage, V <sub>DD</sub> <sup>(1)</sup> |                          | 3   | 25  | V    |
| Input voltage                                  | V3–V2 or V2–V1 or V1–VSS | 0   | 5   | V    |
| Operating ambient temperature, T <sub>A</sub>  |                          | –40 | 110 | °C   |

- (1) See [Typical Application](#).

### 7.4 Thermal Information

| THERMAL METRIC <sup>(1)</sup> |  | bq2945xx  | UNIT |
|-------------------------------|--|-----------|------|
|                               |  | DRV (SON) |      |
|                               |  | 6 PINS    |      |
| R <sub>θJA</sub>              | Junction-to-ambient thermal resistance       | 186.4     | °C/W |
| R <sub>θJC(top)</sub>         | Junction-to-case(top) thermal resistance     | 90.4      | °C/W |
| R <sub>θJB</sub>              | Junction-to-board thermal resistance         | 110.7     | °C/W |
| ψ <sub>JT</sub>               | Junction-to-top characterization parameter   | 96.7      | °C/W |
| ψ <sub>JB</sub>               | Junction-to-board characterization parameter | 90        | °C/W |
| R <sub>θJC(bot)</sub>         | Junction-to-case(bottom) thermal resistance  | N/A       | °C/W |

- (1) For more information about traditional and new thermal metrics, see the [Semiconductor and IC Package Thermal Metrics](#) application report.

## 7.5 Electrical Characteristics

Typical values stated where  $T_A = 25^\circ\text{C}$  and  $V_{DD} = 10.8\text{ V}$ , MIN/MAX values stated where  $T_A = -40^\circ\text{C}$  to  $+110^\circ\text{C}$  and  $V_{DD} = 3\text{ V}$  to  $15\text{ V}$  (unless otherwise noted).

| PARAMETER                               | TEST CONDITIONS                            | MIN  | TYP  | MAX            | UNIT |               |
|---|--|--|------|----------------|------|---------------|
| <b>VOLTAGE PROTECTION THRESHOLD VCx</b> |  |  |      |                |      |               |
| $V_{OV}$                                | $V_{(PROTECT)} -$<br>Overvoltage Detection | bq294502, fixed delay 4 s  |      | 4.35           | V    |               |
|   |  | bq294504, fixed delay 6.5 s  |      | 4.35           |      |               |
|   |  | bq294506, fixed delay 4 s <sup>(1)</sup>   |      | 4.38           |      |               |
|   |  | bq294512, fixed delay 4 s  |      | 4.4            |      |               |
|   |  | bq294522, fixed delay 4 s  |      | 4.45           |      |               |
|   |  | bq294524, fixed delay 6.5 s  |      | 4.45           |      |               |
|   |  | bq294532, fixed delay 4 s  |      | 4.5            |      |               |
|   |  | bq294533, fixed delay 6.5 s  |      | 4.5            |      |               |
|   |  | bq294582, fixed delay 4 s  |      | 4.225          |      |               |
| bq294592, fixed delay 4 s               |  | 4.3  |      |                |      |               |
| $V_{HYS}$                               | Overvoltage Detection Hysteresis           | $V_{HYS}$  | 250  | 300            | 400  | mV            |
| $V_{OA}$                                | OV Detection Accuracy                      | $T_A = 25^\circ\text{C}$ , bq2945xx  | -10  |                | 10   | mV            |
|   |  | $T_A = 25^\circ\text{C}$ , bq294506 only <sup>(1)</sup>  | -7   |                | 7    | mV            |
| $V_{OA-DRIFT}$                          | OV Detection Accuracy due to Temperature   | $T_A = -40^\circ\text{C}$  | -40  |                | 44   | mV            |
|   |  | $T_A = 0^\circ\text{C}$  | -20  |                | 20   |               |
|   |  | $T_A = 60^\circ\text{C}$   | -24  |                | 24   |               |
|   |  | $T_A = 110^\circ\text{C}$  | -54  |                | 54   |               |
|   |  | $T_A = 10^\circ\text{C}$ to $45^\circ\text{C}$ , bq294506 only <sup>(1)</sup>  | -15  |                | 15   | mV            |
| <b>SUPPLY AND LEAKAGE CURRENT</b>       |  |  |      |                |      |               |
| $I_{CC}$                                | Supply Current                             | $(V3-V2) = (V2-V1) = (V1-VSS) = 4\text{ V}$ (See <a href="#">Figure 8</a> for reference.)  |      | 1              | 2    | $\mu\text{A}$ |
|   |  | $(V3-V2) = (V2-V1) = (V1-VSS) = 2.8\text{ V}$ with $T_A = -40^\circ\text{C}$ to $60^\circ\text{C}$   |      |                | 1.25 |               |
| $I_{IN}$                                | Input Current at Vx Pins                   | Measured at V3, V2, and V1 = 4 V<br>$(V2-V1) = (V1-VSS) = 4\text{ V}$<br>$T_A = 0^\circ\text{C}$ to $60^\circ\text{C}$ (See <a href="#">Figure 8</a> for reference.)   | -0.1 |                | 0.1  | $\mu\text{A}$ |
| <b>OUTPUT DRIVE OUT</b>                 |  |  |      |                |      |               |
| $V_{OUT}$                               | Output Drive Voltage                       | $(V3-V2)$ or $(V2-V1)$ or $(V1-VSS) > V_{OV}$<br>$V_{DD} = 7.2\text{ V}$ , $I_{OH} = 100\text{ }\mu\text{A}$ , $T_A = -40^\circ\text{C}$ to $+110^\circ\text{C}$   | 6    |                |      | V             |
|   |  | Two of the three cells are short circuit and only one cell is powered<br>$(V3-V2)$ or $(V2-V1)$ or $(V1-VSS) > V_{OV}$<br>$V_{DD} = V_x$ (Cell voltage), $I_{OH} = 100\text{ }\mu\text{A}$ , $T_A = -40^\circ\text{C}$ to $+110^\circ\text{C}$ |      | $V_{DD} - 0.2$ |      | V             |
|   |  | $(V3-V2)$ , $(V2-V1)$ , and $(V1-VSS) < V_{OV}$ , $I_{OL} = 100\text{ }\mu\text{A}$ , $T_A = 25^\circ\text{C}$<br>$T_A = -40^\circ\text{C}$ to $+110^\circ\text{C}$  |      | 250            | 400  | mV            |
| $I_{OUT(Short)}$                        | OUT Short Circuit Current                  | OUT = 0 V ( $V3-V2$ ) or $(V2-V1)$ or $(V1-VSS) > V_{OV}$  |      |                | 4.5  | mA            |
| $t_R$                                   | Output Rise Time                           | CL = 1 nF, $V_{OH(OUT)} = 0\text{ V}$ to $5\text{ V}$ <sup>(2)</sup>   |      | 5              |      | $\mu\text{s}$ |
| $Z_O$                                   | Output Impedance                           |  |      | 2              | 5    | k $\Omega$    |
| <b>FIXED DELAY TIMER</b>                |  |  |      |                |      |               |
| $t_{DELAY}$                             | Fault Detection Delay Time                 | Fixed Delay, bq2945xx with delay set to 4s typ   | 3.2  | 4              | 4.8  | s             |
|   |  | Fixed Delay, bq2945xx with delay set to 6.5s   | 5.2  | 6.5            | 7.8  |               |
| $t_{DELAY\_CTM}$                        | Fault Detection Delay Time in Test Mode    | Fixed Delay (Internal settings)  |      | 15             |      | ms            |

(1) Advance Information. Contact TI for more information.

(2) Specified by design. Not 100% tested in production.

## 7.6 Typical Characteristics

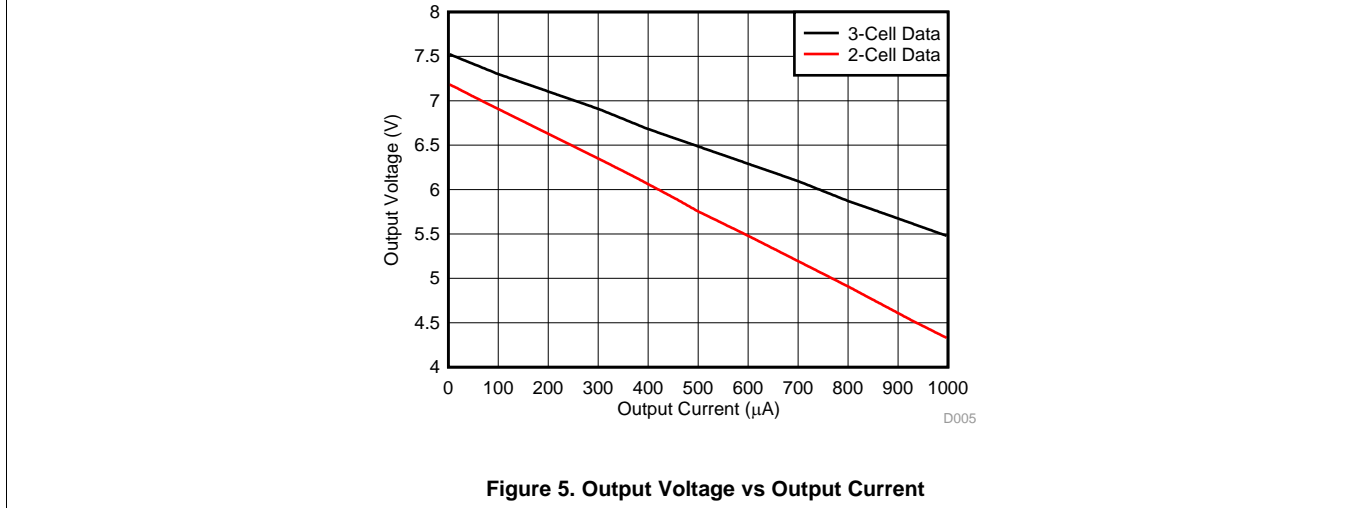
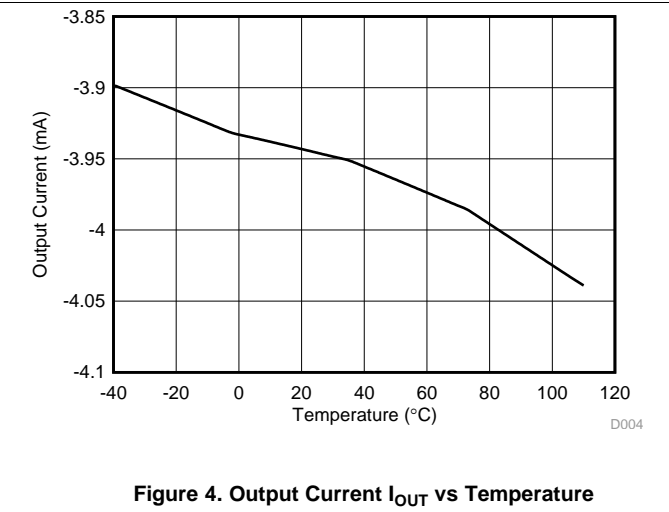
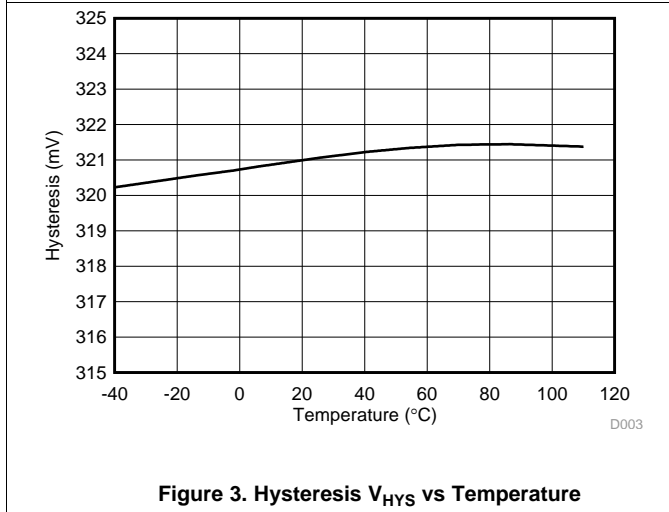
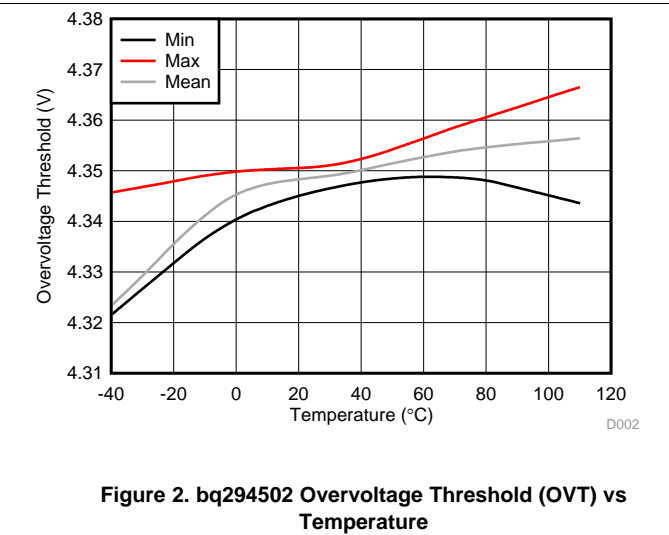
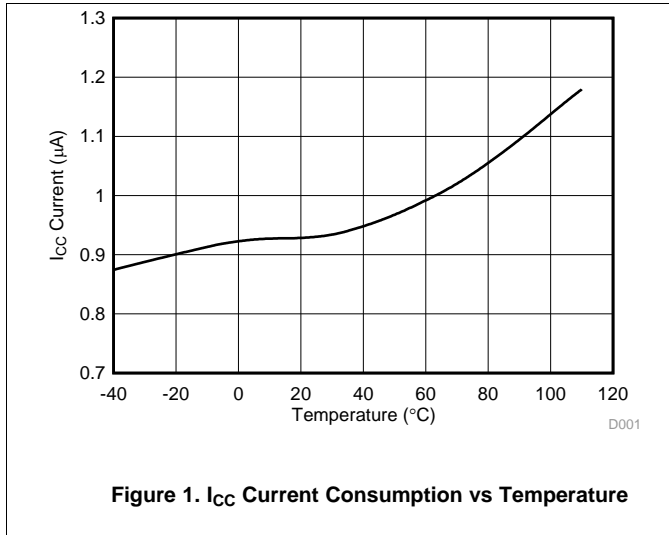

## 8 Detailed Description

### 8.1 Overview

The bq2945xx is a second-level overvoltage (OV) protector. Each cell is monitored independently by comparing the actual cell voltage to a protection voltage threshold,  $V_{OV}$ . The protection threshold is preprogrammed at the factory with a range from 3.85 V to 4.65 V.

### 8.2 Functional Block Diagram

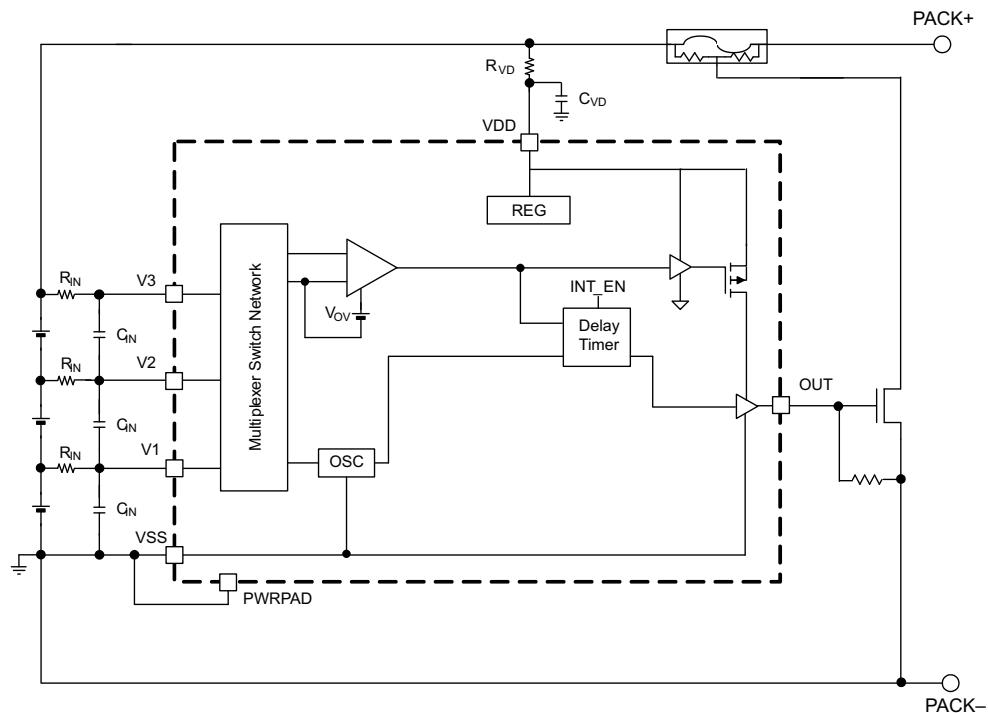

Copyright © 2017, Texas Instruments Incorporated

### 8.3 Feature Description

The voltage sensing for each cell is done independently using a multiplexer. The method of overvoltage detection is comparing the voltage to an overvoltage protection voltage  $V_{OV}$ . Once the voltage exceeds the programmed fixed value, the delay timer circuit is activated. This delay ( $t_{DELAY}$ ) is fixed for either a 4-s or 6.5-s delay. When these conditions are satisfied, the OUT terminal is transitioned to a high level. This output (OUT) is released to a low condition if *all* of the cell inputs ( $V_x$ ) are below the OVP threshold minus the  $V_{Hys}$ .

## Feature Description (continued)

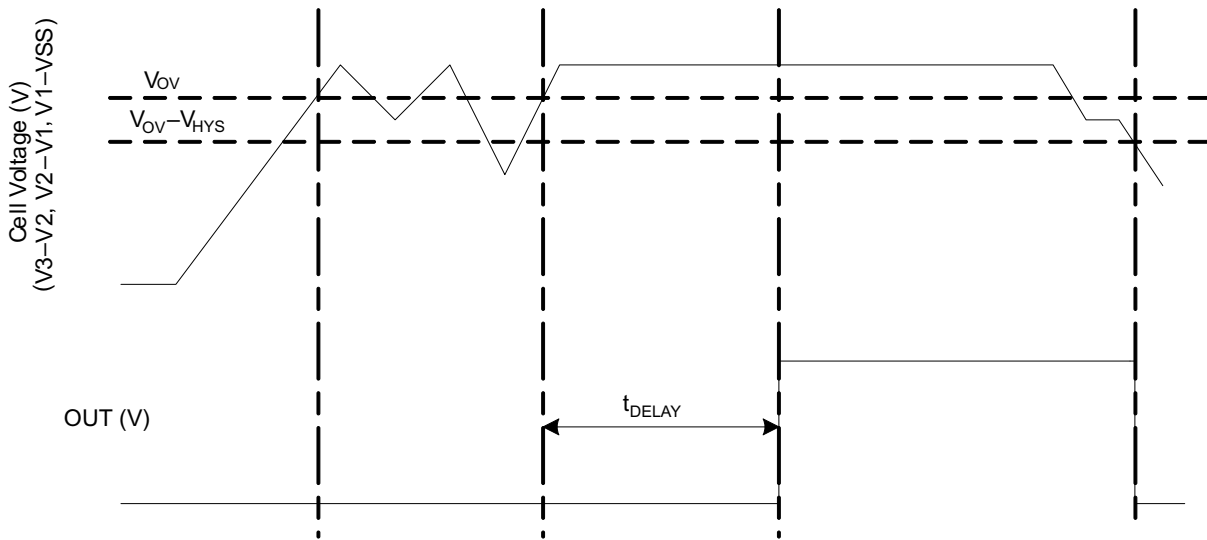

Figure 6. Timing for Overvoltage Sensing

### 8.3.1 Sense Positive Input for VX

This is an input to sense each single battery cell voltage. A series resistor and a capacitor across the cell for each input is required for noise filtering and stable voltage monitoring.

### 8.3.2 Output Drive, OUT

The gate of an external N-channel MOSFET is connected to this terminal. This output transitions to a high level when an overvoltage condition is detected and after the programmed delay timer. OUT will reset to a low level if the cell voltage falls below the  $V_{OV}$  threshold before the fixed delay timer expires.

### 8.3.3 Supply Input, VDD

This terminal is the unregulated input power source for the IC. A series resistor is connected to limit the current, and a capacitor is connected to ground for noise filtering.

### 8.3.4 Thermal Pad, PWRPAD

For correct operation, the power pad (PWRPAD) is connected to the  $V_{SS}$  terminal on the PCB.

## 8.4 Device Functional Modes

### 8.4.1 NORMAL Mode

When all of the cell voltages are below the overvoltage threshold,  $V_{OV}$ , the device operates in NORMAL mode. The device monitors the differential cell voltages connected across ( $V1-VSS$ ), ( $V2-V1$ ) and ( $V3-V2$ ). The OUT pin is inactive in this mode.

### 8.4.2 OVERVOLTAGE Mode

OVERVOLTAGE mode is detected if any of the cell voltages exceeds the overvoltage threshold,  $V_{OV}$  for the configured OV delay time,  $t_{DELAY}$ . The OUT pin will pull high internally. An external FET then turns on, shorting the fuse to ground, which allows the battery or charger power to blow the fuse. When all of the cell voltages fall below ( $V_{OV}-V_{HYS}$ ), the device returns to NORMAL mode.

## Device Functional Modes (continued)

### 8.4.3 Customer Test Mode

Customer Test Mode (CTM) helps to reduce test time for checking the overvoltage delay timer parameter once the circuit is implemented in the battery pack. To enter CTM, VDD should be set to at least 10 V higher than V3 (see Figure 7). The delay timer is greater than 10 ms, but considerably shorter than the timer delay in normal operation. To exit CTM, remove the VDD to VC3 voltage differential of 10 V so that the decrease in this value automatically causes an exit.

**CAUTION**

Avoid exceeding any Absolute Maximum Voltages on any pins when placing the part into CTM. Also avoid exceeding Absolute Maximum Voltages for the individual cell voltages (V3–V2), (V2–V1), and (V1–VSS). Stressing the pins beyond the rated limits may cause permanent damage to the device.

Figure 7 shows the timing for CTM.

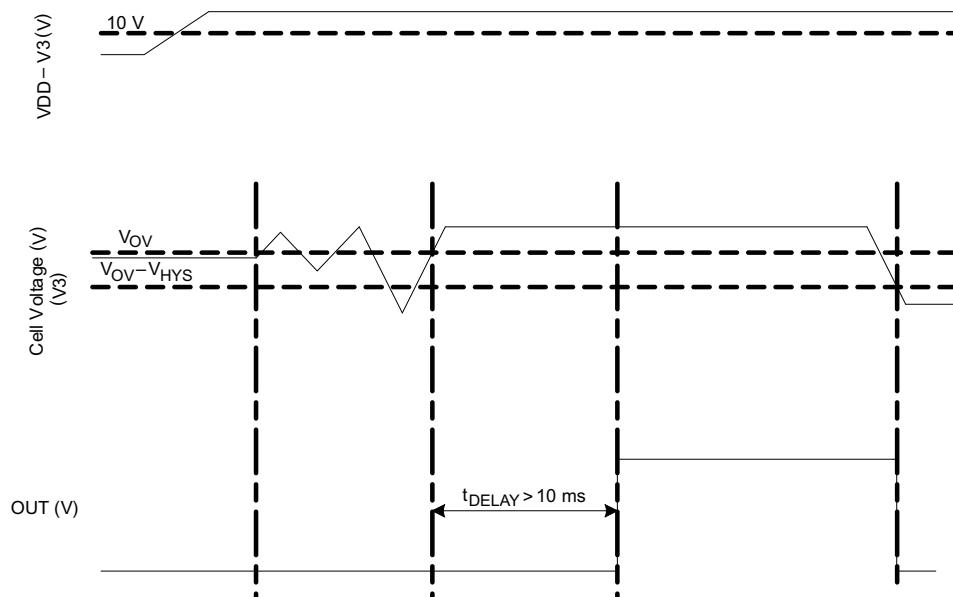

Figure 7. Timing for Customer Test Mode

Figure 8 shows the measurement for current consumption for the product for both VDD and Vx.

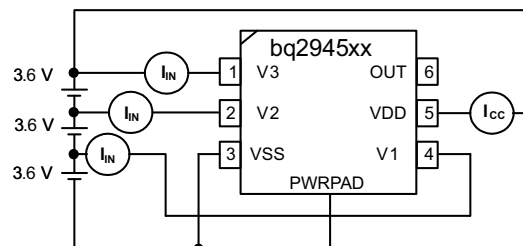

Figure 8. Configuration for IC Current Consumption Test

## 9 Application and Implementation

### NOTE

Information in the following applications sections is not part of the TI component specification, and TI does not warrant its accuracy or completeness. TI's customers are responsible for determining suitability of components for their purposes. Customers should validate and test their design implementation to confirm system functionality.

### 9.1 Application Information

The bq2945xx devices are a family of second-level protectors used for overvoltage protection of the battery pack in the application. The device, when configuring the OUT pin with active high, drives a NMOS FET that connects the fuse to ground in the event of a fault condition. This provides a shorted path to use the battery or charger power to blow the fuse and cut the power path.

### 9.2 Typical Application

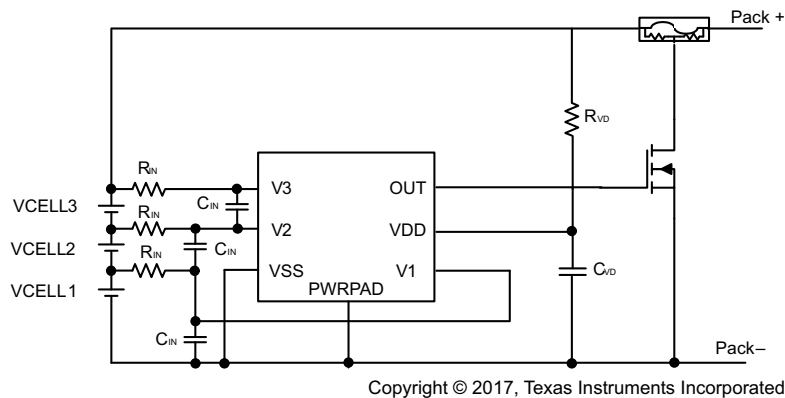

Figure 9. Application Configuration Schematic

#### 9.2.1 Design Requirements

Changes to the ranges stated in [Table 1](#) will impact the accuracy of the cell measurements. [Figure 9](#) shows each external component.

Table 1. Parameters

| PARAMETER                          | EXTERNAL COMPONENT | MIN | TYP  | MAX  | UNIT          |
|------------------------------------|--------------------|-----|------|------|---------------|
| Voltage monitor filter resistance  | RIN                | 100 | 1000 | 4700 | $\Omega$      |
| Voltage monitor filter capacitance | CIN                | 0.1 |      | 1    | $\mu\text{F}$ |
| Supply voltage filter resistance   | RVD                | 100 |      | 1K   | $\Omega$      |
| Supply voltage filter capacitance  | CVD                |     | 0.1  |      | $\mu\text{F}$ |

#### 9.2.2 Detailed Design Procedure

1. Determine the overvoltage threshold and delay time. Select the proper device from the table in [Device Comparison Table](#), or contact TI for a different configuration.
2. Determine the number of cell in series. The device supports 2-S to 3-S cell configuration. For 2-S configuration, V3 pin should be shorted to V2.
3. Follow the application configuration schematic (see [Figure 9](#)) to connect the device.

### 9.2.3 Application Curves

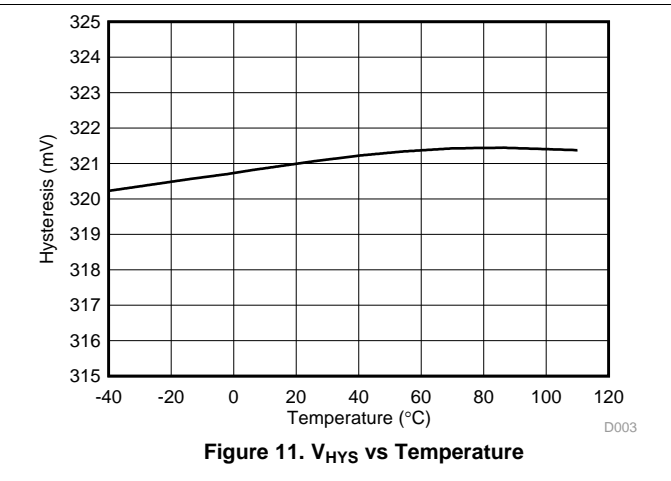
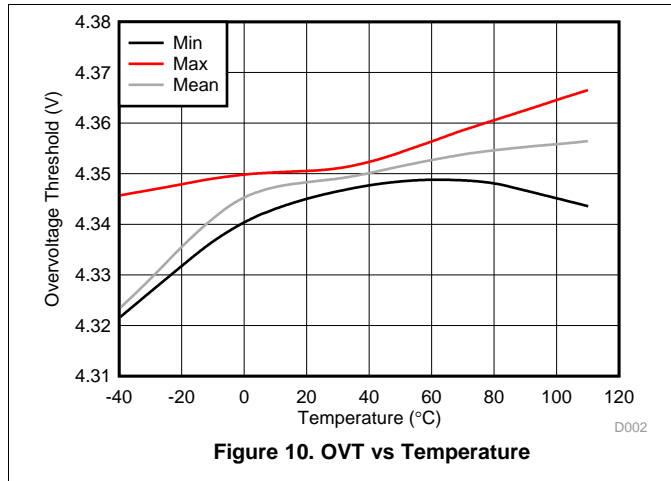

### 9.3 System Examples

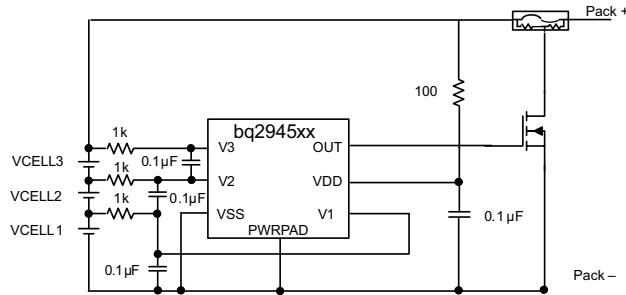

**Figure 12. 3-Series Cell Configuration With Fixed Delay**

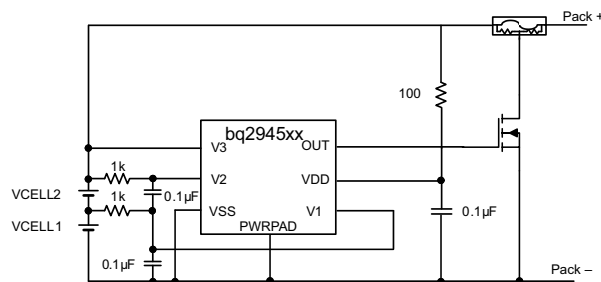

**Figure 13. 2-Series Cell Configuration With Internal Fixed Delay**

## 10 Power Supply Recommendations

The maximum power of this device is 25 V on VDD.

## 11 Layout

### 11.1 Layout Guidelines

- Ensure the RC filters for the V1 and VDD pins are placed as close as possible to the target terminal, reducing the tracing loop area.
- The VSS pin should be routed to the CELL– terminal.
- Ensure the trace connecting the fuse to the gate, source of the NFET to the Pack– is sufficient to withstand the current during a fuse blown event.

### 11.2 Layout Example

Place the RC filters close to the device terminals

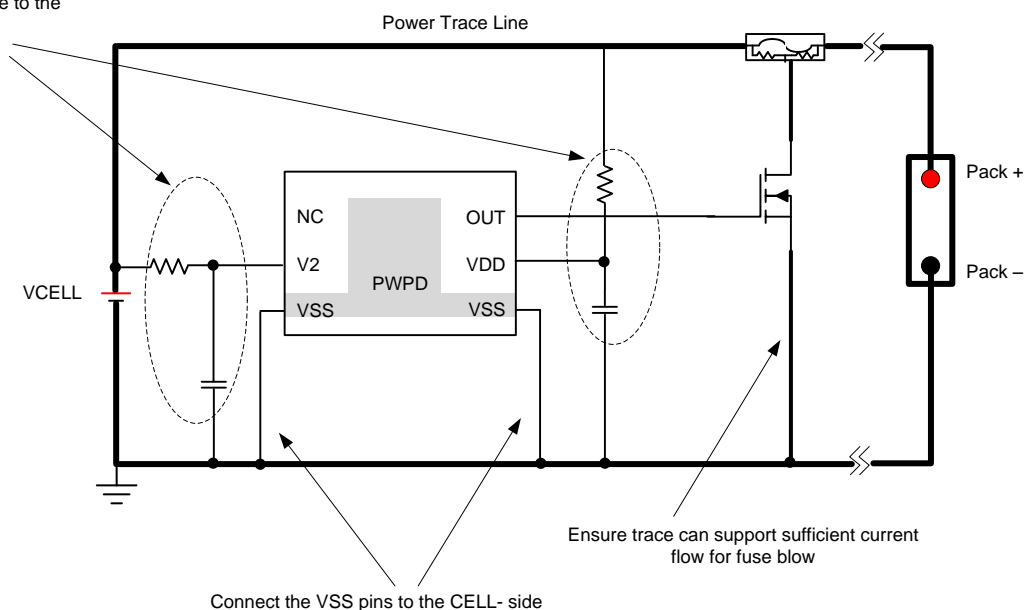

**Figure 14. Layout Schematic**

## 12 Device and Documentation Support

### 12.1 Device Support

#### 12.1.1 Third-Party Products Disclaimer

TI'S PUBLICATION OF INFORMATION REGARDING THIRD-PARTY PRODUCTS OR SERVICES DOES NOT CONSTITUTE AN ENDORSEMENT REGARDING THE SUITABILITY OF SUCH PRODUCTS OR SERVICES OR A WARRANTY, REPRESENTATION OR ENDORSEMENT OF SUCH PRODUCTS OR SERVICES, EITHER ALONE OR IN COMBINATION WITH ANY TI PRODUCT OR SERVICE.

### 12.2 Related Links

The table below lists quick access links. Categories include technical documents, support and community resources, tools and software, and quick access to sample or buy.

**Table 2. Related Links**

| PARTS    | PRODUCT FOLDER             | SAMPLE & BUY               | TECHNICAL DOCUMENTS        | TOOLS & SOFTWARE           | SUPPORT & COMMUNITY        |
|----------|----------------------------|----------------------------|----------------------------|----------------------------|----------------------------|
| bq294502 | <a href="#">Click here</a> | <a href="#">Click here</a> | <a href="#">Click here</a> | <a href="#">Click here</a> | <a href="#">Click here</a> |
| bq294504 | <a href="#">Click here</a> | <a href="#">Click here</a> | <a href="#">Click here</a> | <a href="#">Click here</a> | <a href="#">Click here</a> |
| bq294512 | <a href="#">Click here</a> | <a href="#">Click here</a> | <a href="#">Click here</a> | <a href="#">Click here</a> | <a href="#">Click here</a> |
| bq294522 | <a href="#">Click here</a> | <a href="#">Click here</a> | <a href="#">Click here</a> | <a href="#">Click here</a> | <a href="#">Click here</a> |
| bq294524 | <a href="#">Click here</a> | <a href="#">Click here</a> | <a href="#">Click here</a> | <a href="#">Click here</a> | <a href="#">Click here</a> |
| bq294532 | <a href="#">Click here</a> | <a href="#">Click here</a> | <a href="#">Click here</a> | <a href="#">Click here</a> | <a href="#">Click here</a> |
| bq294533 | <a href="#">Click here</a> | <a href="#">Click here</a> | <a href="#">Click here</a> | <a href="#">Click here</a> | <a href="#">Click here</a> |
| bq294582 | <a href="#">Click here</a> | <a href="#">Click here</a> | <a href="#">Click here</a> | <a href="#">Click here</a> | <a href="#">Click here</a> |
| bq294592 | <a href="#">Click here</a> | <a href="#">Click here</a> | <a href="#">Click here</a> | <a href="#">Click here</a> | <a href="#">Click here</a> |

### 12.3 Receiving Notification of Documentation Updates

To receive notification of documentation updates, navigate to the device product folder on ti.com. In the upper right corner, click on *Alert me* to register and receive a weekly digest of any product information that has changed. For change details, review the revision history included in any revised document.

### 12.4 Community Resources

The following links connect to TI community resources. Linked contents are provided "AS IS" by the respective contributors. They do not constitute TI specifications and do not necessarily reflect TI's views; see TI's [Terms of Use](#).

**TI E2E™ Online Community** *TI's Engineer-to-Engineer (E2E) Community*. Created to foster collaboration among engineers. At e2e.ti.com, you can ask questions, share knowledge, explore ideas and help solve problems with fellow engineers.

**Design Support** *TI's Design Support* Quickly find helpful E2E forums along with design support tools and contact information for technical support.

### 12.5 Trademarks

E2E is a trademark of Texas Instruments.  
 All other trademarks are the property of their respective owners.

### 12.6 Electrostatic Discharge Caution



These devices have limited built-in ESD protection. The leads should be shorted together or the device placed in conductive foam during storage or handling to prevent electrostatic damage to the MOS gates.

## 12.7 Glossary

[SLYZ022](#) — *TI Glossary*.

This glossary lists and explains terms, acronyms, and definitions.

## 13 Mechanical, Packaging, and Orderable Information

The following pages include mechanical, packaging, and orderable information. This information is the most current data available for the designated devices. This data is subject to change without notice and revision of this document. For browser-based versions of this data sheet, refer to the left-hand navigation.

**PACKAGING INFORMATION**

| Orderable Device | Status<br>(1) | Package Type | Package<br>Drawing | Pins | Package<br>Qty | Eco Plan<br>(2)            | Lead/Ball Finish<br>(6) | MSL Peak Temp<br>(3) | Op Temp (°C) | Device Marking<br>(4/5) | Samples                 |
|------------------|---------------|--------------|--------------------|------|----------------|----------------------------|-------------------------|----------------------|--------------|-------------------------|-------------------------|
| BQ294502DRVR     | ACTIVE        | WSO          | DRV                | 6    | 3000           | Green (RoHS<br>& no Sb/Br) | CU NIPDAU               | Level-2-260C-1 YEAR  | -40 to 85    | 4502                    | <a href="#">Samples</a> |
| BQ294502DRVT     | ACTIVE        | WSO          | DRV                | 6    | 250            | Green (RoHS<br>& no Sb/Br) | CU NIPDAU               | Level-2-260C-1 YEAR  | -40 to 85    | 4502                    | <a href="#">Samples</a> |
| BQ294504DRVR     | ACTIVE        | WSO          | DRV                | 6    | 3000           | Green (RoHS<br>& no Sb/Br) | CU NIPDAU               | Level-2-260C-1 YEAR  | -40 to 85    | 4504                    | <a href="#">Samples</a> |
| BQ294504DRVT     | ACTIVE        | WSO          | DRV                | 6    | 250            | Green (RoHS<br>& no Sb/Br) | CU NIPDAU               | Level-2-260C-1 YEAR  | -40 to 85    | 4504                    | <a href="#">Samples</a> |
| BQ294512DRVR     | ACTIVE        | WSO          | DRV                | 6    | 3000           | Green (RoHS<br>& no Sb/Br) | CU NIPDAU               | Level-2-260C-1 YEAR  | -40 to 85    | 4512                    | <a href="#">Samples</a> |
| BQ294512DRVT     | ACTIVE        | WSO          | DRV                | 6    | 250            | Green (RoHS<br>& no Sb/Br) | CU NIPDAU               | Level-2-260C-1 YEAR  | -40 to 85    | 4512                    | <a href="#">Samples</a> |
| BQ294522DRVR     | ACTIVE        | WSO          | DRV                | 6    | 3000           | Green (RoHS<br>& no Sb/Br) | CU NIPDAU               | Level-2-260C-1 YEAR  | -40 to 85    | 4522                    | <a href="#">Samples</a> |
| BQ294522DRVT     | ACTIVE        | WSO          | DRV                | 6    | 250            | Green (RoHS<br>& no Sb/Br) | CU NIPDAU               | Level-2-260C-1 YEAR  | -40 to 85    | 4522                    | <a href="#">Samples</a> |
| BQ294524DRVR     | ACTIVE        | WSO          | DRV                | 6    | 3000           | Green (RoHS<br>& no Sb/Br) | CU NIPDAU               | Level-2-260C-1 YEAR  | -40 to 85    | 4524                    | <a href="#">Samples</a> |
| BQ294524DRVT     | ACTIVE        | WSO          | DRV                | 6    | 250            | Green (RoHS<br>& no Sb/Br) | CU NIPDAU               | Level-2-260C-1 YEAR  | -40 to 85    | 4524                    | <a href="#">Samples</a> |
| BQ294532DRVR     | ACTIVE        | WSO          | DRV                | 6    | 3000           | Green (RoHS<br>& no Sb/Br) | CU NIPDAU               | Level-2-260C-1 YEAR  | -40 to 85    | 4532                    | <a href="#">Samples</a> |
| BQ294532DRVT     | ACTIVE        | WSO          | DRV                | 6    | 250            | Green (RoHS<br>& no Sb/Br) | CU NIPDAU               | Level-2-260C-1 YEAR  | -40 to 85    | 4532                    | <a href="#">Samples</a> |
| BQ294533DRVR     | ACTIVE        | WSO          | DRV                | 6    | 3000           | Green (RoHS<br>& no Sb/Br) | CU NIPDAU               | Level-2-260C-1 YEAR  | -40 to 85    | 4533                    | <a href="#">Samples</a> |
| BQ294533DRVT     | ACTIVE        | WSO          | DRV                | 6    | 250            | Green (RoHS<br>& no Sb/Br) | CU NIPDAU               | Level-2-260C-1 YEAR  | -40 to 85    | 4533                    | <a href="#">Samples</a> |
| BQ294582DRVR     | ACTIVE        | WSO          | DRV                | 6    | 3000           | Green (RoHS<br>& no Sb/Br) | CU NIPDAU               | Level-2-260C-1 YEAR  | -40 to 85    | 4582                    | <a href="#">Samples</a> |
| BQ294582DRVT     | ACTIVE        | WSO          | DRV                | 6    | 250            | Green (RoHS<br>& no Sb/Br) | CU NIPDAU               | Level-2-260C-1 YEAR  | -40 to 85    | 4582                    | <a href="#">Samples</a> |
| BQ294592DRVR     | ACTIVE        | WSO          | DRV                | 6    | 3000           | Green (RoHS<br>& no Sb/Br) | CU NIPDAU               | Level-2-260C-1 YEAR  | -40 to 85    | 4592                    | <a href="#">Samples</a> |

| Orderable Device | Status<br>(1) | Package Type | Package<br>Drawing | Pins | Package<br>Qty | Eco Plan<br>(2)            | Lead/Ball Finish<br>(6) | MSL Peak Temp<br>(3) | Op Temp (°C) | Device Marking<br>(4/5) | Samples        |
|------------------|---------------|--------------|--------------------|------|----------------|----------------------------|-------------------------|----------------------|--------------|-------------------------|----------------|
| BQ294592DRV1     | ACTIVE        | WSON         | DRV                | 6    | 250            | Green (RoHS<br>& no Sb/Br) | CU NIPDAU               | Level-2-260C-1 YEAR  | -40 to 85    | 4592                    | <b>Samples</b> |

(1) The marketing status values are defined as follows:

**ACTIVE:** Product device recommended for new designs.

**LIFEBUY:** TI has announced that the device will be discontinued, and a lifetime-buy period is in effect.

**NRND:** Not recommended for new designs. Device is in production to support existing customers, but TI does not recommend using this part in a new design.

**PREVIEW:** Device has been announced but is not in production. Samples may or may not be available.

**OBSOLETE:** TI has discontinued the production of the device.

(2) **RoHS:** TI defines "RoHS" to mean semiconductor products that are compliant with the current EU RoHS requirements for all 10 RoHS substances, including the requirement that RoHS substance do not exceed 0.1% by weight in homogeneous materials. Where designed to be soldered at high temperatures, "RoHS" products are suitable for use in specified lead-free processes. TI may reference these types of products as "Pb-Free".

**RoHS Exempt:** TI defines "RoHS Exempt" to mean products that contain lead but are compliant with EU RoHS pursuant to a specific EU RoHS exemption.

**Green:** TI defines "Green" to mean the content of Chlorine (Cl) and Bromine (Br) based flame retardants meet JS709B low halogen requirements of <=1000ppm threshold. Antimony trioxide based flame retardants must also meet the <=1000ppm threshold requirement.

(3) MSL, Peak Temp. - The Moisture Sensitivity Level rating according to the JEDEC industry standard classifications, and peak solder temperature.

(4) There may be additional marking, which relates to the logo, the lot trace code information, or the environmental category on the device.

(5) Multiple Device Markings will be inside parentheses. Only one Device Marking contained in parentheses and separated by a "~" will appear on a device. If a line is indented then it is a continuation of the previous line and the two combined represent the entire Device Marking for that device.

(6) Lead/Ball Finish - Orderable Devices may have multiple material finish options. Finish options are separated by a vertical ruled line. Lead/Ball Finish values may wrap to two lines if the finish value exceeds the maximum column width.

**Important Information and Disclaimer:** The information provided on this page represents TI's knowledge and belief as of the date that it is provided. TI bases its knowledge and belief on information provided by third parties, and makes no representation or warranty as to the accuracy of such information. Efforts are underway to better integrate information from third parties. TI has taken and continues to take reasonable steps to provide representative and accurate information but may not have conducted destructive testing or chemical analysis on incoming materials and chemicals. TI and TI suppliers consider certain information to be proprietary, and thus CAS numbers and other limited information may not be available for release.

In no event shall TI's liability arising out of such information exceed the total purchase price of the TI part(s) at issue in this document sold by TI to Customer on an annual basis.

## TAPE AND REEL INFORMATION

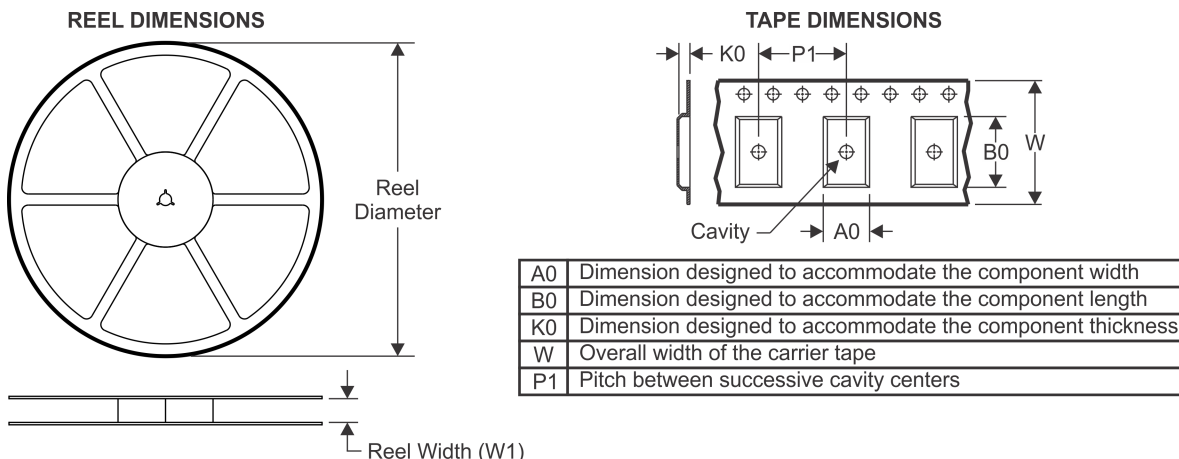

### QUADRANT ASSIGNMENTS FOR PIN 1 ORIENTATION IN TAPE



\*All dimensions are nominal

| Device       | Package Type | Package Drawing | Pins | SPQ  | Reel Diameter (mm) | Reel Width W1 (mm) | A0 (mm) | B0 (mm) | K0 (mm) | P1 (mm) | W (mm) | Pin1 Quadrant |
|--------------|--------------|-----------------|------|------|--------------------|--------------------|---------|---------|---------|---------|--------|---------------|
| BQ294502DRVR | WSO          | DRV             | 6    | 3000 | 180.0              | 8.4                | 2.3     | 2.3     | 1.15    | 4.0     | 8.0    | Q2            |
| BQ294502DRVR | WSO          | DRV             | 6    | 3000 | 180.0              | 8.4                | 2.3     | 2.3     | 1.15    | 4.0     | 8.0    | Q2            |
| BQ294502DRVT | WSO          | DRV             | 6    | 250  | 180.0              | 8.4                | 2.3     | 2.3     | 1.15    | 4.0     | 8.0    | Q2            |
| BQ294502DRVT | WSO          | DRV             | 6    | 250  | 180.0              | 8.4                | 2.3     | 2.3     | 1.15    | 4.0     | 8.0    | Q2            |
| BQ294504DRVR | WSO          | DRV             | 6    | 3000 | 180.0              | 8.4                | 2.3     | 2.3     | 1.15    | 4.0     | 8.0    | Q2            |
| BQ294504DRVR | WSO          | DRV             | 6    | 3000 | 180.0              | 8.4                | 2.3     | 2.3     | 1.15    | 4.0     | 8.0    | Q2            |
| BQ294504DRVT | WSO          | DRV             | 6    | 250  | 180.0              | 8.4                | 2.3     | 2.3     | 1.15    | 4.0     | 8.0    | Q2            |
| BQ294504DRVT | WSO          | DRV             | 6    | 250  | 180.0              | 8.4                | 2.3     | 2.3     | 1.15    | 4.0     | 8.0    | Q2            |
| BQ294512DRVR | WSO          | DRV             | 6    | 3000 | 180.0              | 8.4                | 2.3     | 2.3     | 1.15    | 4.0     | 8.0    | Q2            |
| BQ294512DRVT | WSO          | DRV             | 6    | 250  | 180.0              | 8.4                | 2.3     | 2.3     | 1.15    | 4.0     | 8.0    | Q2            |
| BQ294522DRVR | WSO          | DRV             | 6    | 3000 | 180.0              | 8.4                | 2.3     | 2.3     | 1.15    | 4.0     | 8.0    | Q2            |
| BQ294522DRVT | WSO          | DRV             | 6    | 250  | 180.0              | 8.4                | 2.3     | 2.3     | 1.15    | 4.0     | 8.0    | Q2            |
| BQ294524DRVR | WSO          | DRV             | 6    | 3000 | 180.0              | 8.4                | 2.3     | 2.3     | 1.15    | 4.0     | 8.0    | Q2            |
| BQ294524DRVR | WSO          | DRV             | 6    | 3000 | 180.0              | 8.4                | 2.3     | 2.3     | 1.15    | 4.0     | 8.0    | Q2            |
| BQ294524DRVT | WSO          | DRV             | 6    | 250  | 180.0              | 8.4                | 2.3     | 2.3     | 1.15    | 4.0     | 8.0    | Q2            |
| BQ294524DRVT | WSO          | DRV             | 6    | 250  | 180.0              | 8.4                | 2.3     | 2.3     | 1.15    | 4.0     | 8.0    | Q2            |
| BQ294532DRVR | WSO          | DRV             | 6    | 3000 | 180.0              | 8.4                | 2.3     | 2.3     | 1.15    | 4.0     | 8.0    | Q2            |
| BQ294532DRVR | WSO          | DRV             | 6    | 3000 | 180.0              | 8.4                | 2.3     | 2.3     | 1.15    | 4.0     | 8.0    | Q2            |

| Device       | Package Type | Package Drawing | Pins | SPQ  | Reel Diameter (mm) | Reel Width W1 (mm) | A0 (mm) | B0 (mm) | K0 (mm) | P1 (mm) | W (mm) | Pin1 Quadrant |
|--------------|--------------|-----------------|------|------|--------------------|--------------------|---------|---------|---------|---------|--------|---------------|
| BQ294532DRVT | WSON         | DRV             | 6    | 250  | 180.0              | 8.4                | 2.3     | 2.3     | 1.15    | 4.0     | 8.0    | Q2            |
| BQ294532DRVT | WSON         | DRV             | 6    | 250  | 180.0              | 8.4                | 2.3     | 2.3     | 1.15    | 4.0     | 8.0    | Q2            |
| BQ294533DRVR | WSON         | DRV             | 6    | 3000 | 180.0              | 8.4                | 2.3     | 2.3     | 1.15    | 4.0     | 8.0    | Q2            |
| BQ294533DRVT | WSON         | DRV             | 6    | 250  | 180.0              | 8.4                | 2.3     | 2.3     | 1.15    | 4.0     | 8.0    | Q2            |
| BQ294582DRVR | WSON         | DRV             | 6    | 3000 | 180.0              | 8.4                | 2.3     | 2.3     | 1.15    | 4.0     | 8.0    | Q2            |
| BQ294582DRVR | WSON         | DRV             | 6    | 3000 | 180.0              | 8.4                | 2.3     | 2.3     | 1.15    | 4.0     | 8.0    | Q2            |
| BQ294582DRVT | WSON         | DRV             | 6    | 250  | 180.0              | 8.4                | 2.3     | 2.3     | 1.15    | 4.0     | 8.0    | Q2            |
| BQ294582DRVT | WSON         | DRV             | 6    | 250  | 180.0              | 8.4                | 2.3     | 2.3     | 1.15    | 4.0     | 8.0    | Q2            |
| BQ294592DRVR | WSON         | DRV             | 6    | 3000 | 180.0              | 8.4                | 2.3     | 2.3     | 1.15    | 4.0     | 8.0    | Q2            |
| BQ294592DRVR | WSON         | DRV             | 6    | 3000 | 180.0              | 8.4                | 2.3     | 2.3     | 1.15    | 4.0     | 8.0    | Q2            |
| BQ294592DRVT | WSON         | DRV             | 6    | 250  | 180.0              | 8.4                | 2.3     | 2.3     | 1.15    | 4.0     | 8.0    | Q2            |
| BQ294592DRVT | WSON         | DRV             | 6    | 250  | 180.0              | 8.4                | 2.3     | 2.3     | 1.15    | 4.0     | 8.0    | Q2            |

### TAPE AND REEL BOX DIMENSIONS

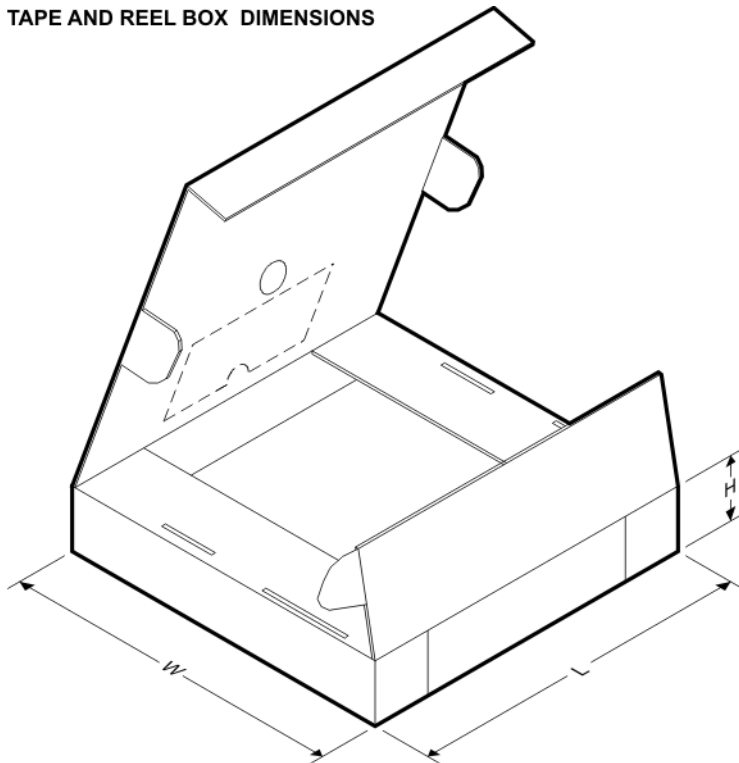

\*All dimensions are nominal

| Device       | Package Type | Package Drawing | Pins | SPQ  | Length (mm) | Width (mm) | Height (mm) |
|--------------|--------------|-----------------|------|------|-------------|------------|-------------|
| BQ294502DRVR | WSON         | DRV             | 6    | 3000 | 210.0       | 185.0      | 35.0        |
| BQ294502DRVR | WSON         | DRV             | 6    | 3000 | 210.0       | 185.0      | 35.0        |
| BQ294502DRVT | WSON         | DRV             | 6    | 250  | 210.0       | 185.0      | 35.0        |
| BQ294502DRVT | WSON         | DRV             | 6    | 250  | 210.0       | 185.0      | 35.0        |
| BQ294504DRVR | WSON         | DRV             | 6    | 3000 | 210.0       | 185.0      | 35.0        |

| Device       | Package Type | Package Drawing | Pins | SPQ  | Length (mm) | Width (mm) | Height (mm) |
|--------------|--------------|-----------------|------|------|-------------|------------|-------------|
| BQ294504DRVR | WSON         | DRV             | 6    | 3000 | 210.0       | 185.0      | 35.0        |
| BQ294504DRVT | WSON         | DRV             | 6    | 250  | 210.0       | 185.0      | 35.0        |
| BQ294504DRVT | WSON         | DRV             | 6    | 250  | 210.0       | 185.0      | 35.0        |
| BQ294512DRVR | WSON         | DRV             | 6    | 3000 | 210.0       | 185.0      | 35.0        |
| BQ294512DRVT | WSON         | DRV             | 6    | 250  | 210.0       | 185.0      | 35.0        |
| BQ294522DRVR | WSON         | DRV             | 6    | 3000 | 210.0       | 185.0      | 35.0        |
| BQ294522DRVT | WSON         | DRV             | 6    | 250  | 210.0       | 185.0      | 35.0        |
| BQ294524DRVR | WSON         | DRV             | 6    | 3000 | 210.0       | 185.0      | 35.0        |
| BQ294524DRVR | WSON         | DRV             | 6    | 3000 | 210.0       | 185.0      | 35.0        |
| BQ294524DRVT | WSON         | DRV             | 6    | 250  | 210.0       | 185.0      | 35.0        |
| BQ294524DRVT | WSON         | DRV             | 6    | 250  | 210.0       | 185.0      | 35.0        |
| BQ294532DRVR | WSON         | DRV             | 6    | 3000 | 210.0       | 185.0      | 35.0        |
| BQ294532DRVR | WSON         | DRV             | 6    | 3000 | 210.0       | 185.0      | 35.0        |
| BQ294532DRVT | WSON         | DRV             | 6    | 250  | 210.0       | 185.0      | 35.0        |
| BQ294532DRVT | WSON         | DRV             | 6    | 250  | 210.0       | 185.0      | 35.0        |
| BQ294533DRVR | WSON         | DRV             | 6    | 3000 | 210.0       | 185.0      | 35.0        |
| BQ294533DRVT | WSON         | DRV             | 6    | 250  | 210.0       | 185.0      | 35.0        |
| BQ294582DRVR | WSON         | DRV             | 6    | 3000 | 210.0       | 185.0      | 35.0        |
| BQ294582DRVR | WSON         | DRV             | 6    | 3000 | 210.0       | 185.0      | 35.0        |
| BQ294582DRVT | WSON         | DRV             | 6    | 250  | 210.0       | 185.0      | 35.0        |
| BQ294582DRVT | WSON         | DRV             | 6    | 250  | 210.0       | 185.0      | 35.0        |
| BQ294592DRVR | WSON         | DRV             | 6    | 3000 | 210.0       | 185.0      | 35.0        |
| BQ294592DRVR | WSON         | DRV             | 6    | 3000 | 210.0       | 185.0      | 35.0        |
| BQ294592DRVT | WSON         | DRV             | 6    | 250  | 210.0       | 185.0      | 35.0        |
| BQ294592DRVT | WSON         | DRV             | 6    | 250  | 210.0       | 185.0      | 35.0        |

## GENERIC PACKAGE VIEW

DRV 6

WSON - 0.8 mm max height

PLASTIC SMALL OUTLINE - NO LEAD



Images above are just a representation of the package family, actual package may vary.  
Refer to the product data sheet for package details.

4206925/F

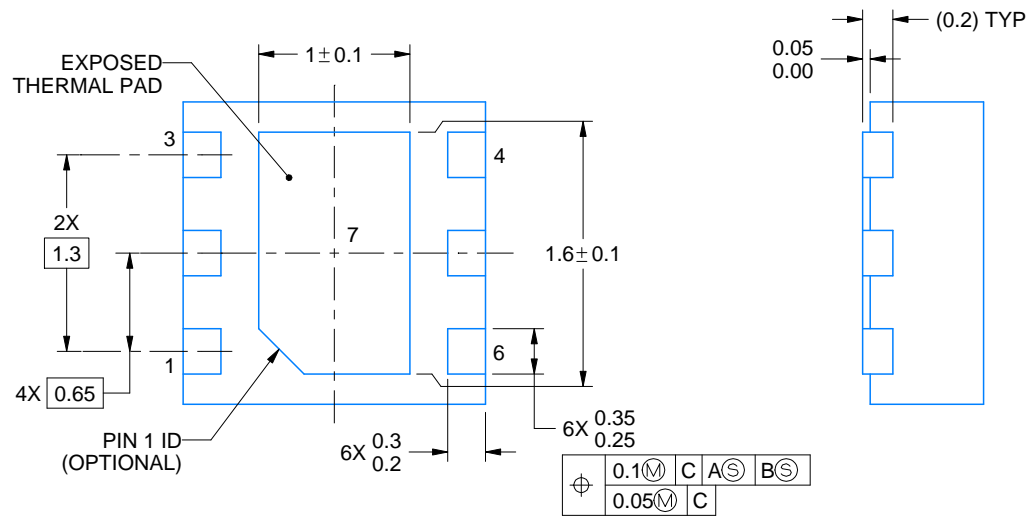
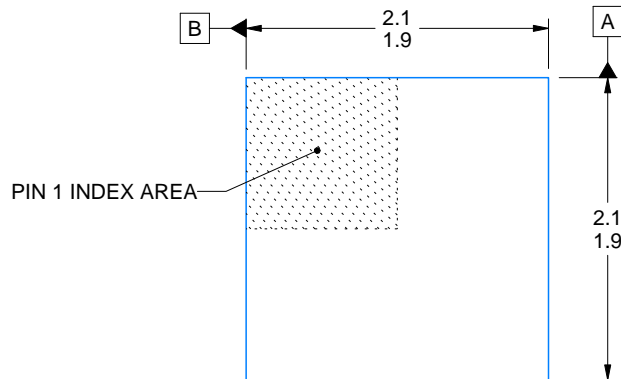
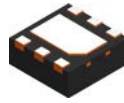

4222173/B 04/2018

NOTES:

1. All linear dimensions are in millimeters. Any dimensions in parenthesis are for reference only. Dimensioning and tolerancing per ASME Y14.5M.
2. This drawing is subject to change without notice.
3. The package thermal pad must be soldered to the printed circuit board for thermal and mechanical performance.

# EXAMPLE BOARD LAYOUT

DRV0006A

WSON - 0.8 mm max height

PLASTIC SMALL OUTLINE - NO LEAD

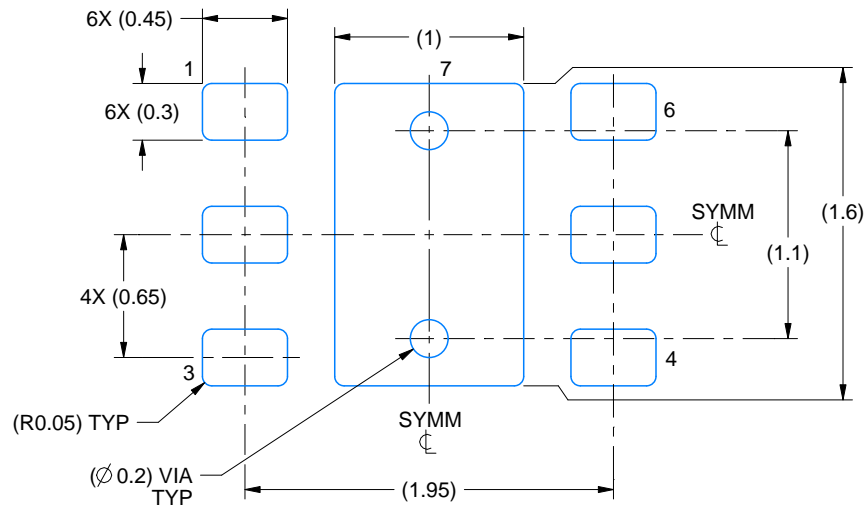

LAND PATTERN EXAMPLE  
SCALE:25X

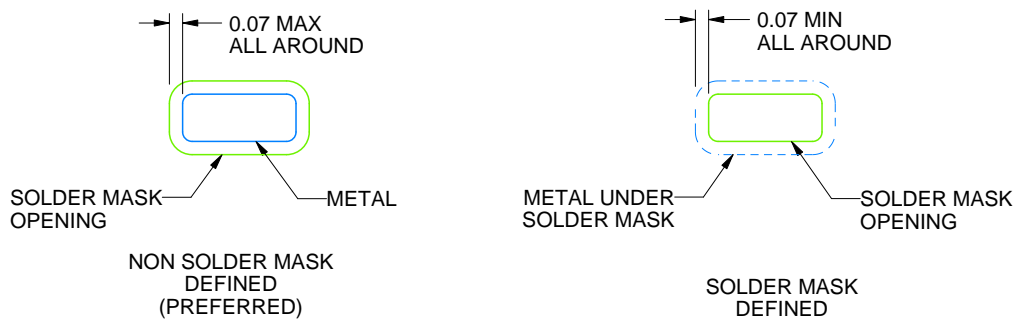

SOLDER MASK DETAILS

4222173/B 04/2018

NOTES: (continued)

4. This package is designed to be soldered to a thermal pad on the board. For more information, see Texas Instruments literature number SLUA271 ([www.ti.com/lit/sluea271](http://www.ti.com/lit/sluea271)).
5. Vias are optional depending on application, refer to device data sheet. If some or all are implemented, recommended via locations are shown.

# EXAMPLE STENCIL DESIGN

DRV0006A

WSON - 0.8 mm max height

PLASTIC SMALL OUTLINE - NO LEAD



SOLDER PASTE EXAMPLE  
BASED ON 0.125 mm THICK STENCIL

EXPOSED PAD #7  
88% PRINTED SOLDER COVERAGE BY AREA UNDER PACKAGE  
SCALE:30X

4222173/B 04/2018

NOTES: (continued)

6. Laser cutting apertures with trapezoidal walls and rounded corners may offer better paste release. IPC-7525 may have alternate design recommendations.

## IMPORTANT NOTICE

Texas Instruments Incorporated (TI) reserves the right to make corrections, enhancements, improvements and other changes to its semiconductor products and services per JESD46, latest issue, and to discontinue any product or service per JESD48, latest issue. Buyers should obtain the latest relevant information before placing orders and should verify that such information is current and complete.

TI's published terms of sale for semiconductor products (<http://www.ti.com/sc/docs/stdterms.htm>) apply to the sale of packaged integrated circuit products that TI has qualified and released to market. Additional terms may apply to the use or sale of other types of TI products and services.

Reproduction of significant portions of TI information in TI data sheets is permissible only if reproduction is without alteration and is accompanied by all associated warranties, conditions, limitations, and notices. TI is not responsible or liable for such reproduced documentation. Information of third parties may be subject to additional restrictions. Resale of TI products or services with statements different from or beyond the parameters stated by TI for that product or service voids all express and any implied warranties for the associated TI product or service and is an unfair and deceptive business practice. TI is not responsible or liable for any such statements.

Buyers and others who are developing systems that incorporate TI products (collectively, "Designers") understand and agree that Designers remain responsible for using their independent analysis, evaluation and judgment in designing their applications and that Designers have full and exclusive responsibility to assure the safety of Designers' applications and compliance of their applications (and of all TI products used in or for Designers' applications) with all applicable regulations, laws and other applicable requirements. Designer represents that, with respect to their applications, Designer has all the necessary expertise to create and implement safeguards that (1) anticipate dangerous consequences of failures, (2) monitor failures and their consequences, and (3) lessen the likelihood of failures that might cause harm and take appropriate actions. Designer agrees that prior to using or distributing any applications that include TI products, Designer will thoroughly test such applications and the functionality of such TI products as used in such applications.

TI's provision of technical, application or other design advice, quality characterization, reliability data or other services or information, including, but not limited to, reference designs and materials relating to evaluation modules, (collectively, "TI Resources") are intended to assist designers who are developing applications that incorporate TI products; by downloading, accessing or using TI Resources in any way, Designer (individually or, if Designer is acting on behalf of a company, Designer's company) agrees to use any particular TI Resource solely for this purpose and subject to the terms of this Notice.

TI's provision of TI Resources does not expand or otherwise alter TI's applicable published warranties or warranty disclaimers for TI products, and no additional obligations or liabilities arise from TI providing such TI Resources. TI reserves the right to make corrections, enhancements, improvements and other changes to its TI Resources. TI has not conducted any testing other than that specifically described in the published documentation for a particular TI Resource.

Designer is authorized to use, copy and modify any individual TI Resource only in connection with the development of applications that include the TI product(s) identified in such TI Resource. NO OTHER LICENSE, EXPRESS OR IMPLIED, BY ESTOPPEL OR OTHERWISE TO ANY OTHER TI INTELLECTUAL PROPERTY RIGHT, AND NO LICENSE TO ANY TECHNOLOGY OR INTELLECTUAL PROPERTY RIGHT OF TI OR ANY THIRD PARTY IS GRANTED HEREIN, including but not limited to any patent right, copyright, mask work right, or other intellectual property right relating to any combination, machine, or process in which TI products or services are used. Information regarding or referencing third-party products or services does not constitute a license to use such products or services, or a warranty or endorsement thereof. Use of TI Resources may require a license from a third party under the patents or other intellectual property of the third party, or a license from TI under the patents or other intellectual property of TI.

TI RESOURCES ARE PROVIDED "AS IS" AND WITH ALL FAULTS. TI DISCLAIMS ALL OTHER WARRANTIES OR REPRESENTATIONS, EXPRESS OR IMPLIED, REGARDING RESOURCES OR USE THEREOF, INCLUDING BUT NOT LIMITED TO ACCURACY OR COMPLETENESS, TITLE, ANY EPIDEMIC FAILURE WARRANTY AND ANY IMPLIED WARRANTIES OF MERCHANTABILITY, FITNESS FOR A PARTICULAR PURPOSE, AND NON-INFRINGEMENT OF ANY THIRD PARTY INTELLECTUAL PROPERTY RIGHTS. TI SHALL NOT BE LIABLE FOR AND SHALL NOT DEFEND OR INDEMNIFY DESIGNER AGAINST ANY CLAIM, INCLUDING BUT NOT LIMITED TO ANY INFRINGEMENT CLAIM THAT RELATES TO OR IS BASED ON ANY COMBINATION OF PRODUCTS EVEN IF DESCRIBED IN TI RESOURCES OR OTHERWISE. IN NO EVENT SHALL TI BE LIABLE FOR ANY ACTUAL, DIRECT, SPECIAL, COLLATERAL, INDIRECT, PUNITIVE, INCIDENTAL, CONSEQUENTIAL OR EXEMPLARY DAMAGES IN CONNECTION WITH OR ARISING OUT OF TI RESOURCES OR USE THEREOF, AND REGARDLESS OF WHETHER TI HAS BEEN ADVISED OF THE POSSIBILITY OF SUCH DAMAGES.

Unless TI has explicitly designated an individual product as meeting the requirements of a particular industry standard (e.g., ISO/TS 16949 and ISO 26262), TI is not responsible for any failure to meet such industry standard requirements.

Where TI specifically promotes products as facilitating functional safety or as compliant with industry functional safety standards, such products are intended to help enable customers to design and create their own applications that meet applicable functional safety standards and requirements. Using products in an application does not by itself establish any safety features in the application. Designers must ensure compliance with safety-related requirements and standards applicable to their applications. Designer may not use any TI products in life-critical medical equipment unless authorized officers of the parties have executed a special contract specifically governing such use. Life-critical medical equipment is medical equipment where failure of such equipment would cause serious bodily injury or death (e.g., life support, pacemakers, defibrillators, heart pumps, neurostimulators, and implantables). Such equipment includes, without limitation, all medical devices identified by the U.S. Food and Drug Administration as Class III devices and equivalent classifications outside the U.S.

TI may expressly designate certain products as completing a particular qualification (e.g., Q100, Military Grade, or Enhanced Product). Designers agree that it has the necessary expertise to select the product with the appropriate qualification designation for their applications and that proper product selection is at Designers' own risk. Designers are solely responsible for compliance with all legal and regulatory requirements in connection with such selection.

Designer will fully indemnify TI and its representatives against any damages, costs, losses, and/or liabilities arising out of Designer's non-compliance with the terms and provisions of this Notice.

## Looking for pricing, stock, or lifecycle information?

Click below to explore more details on WIN SOURCE:

 [View BQ294512DRVR on WIN SOURCE](#)

 [Texas Instruments](#) Information

## Optimize Your Supply Chain with WIN SOURCE Solutions

-  Global Sourcing Solution
-  Obsolete Management
-  Cost Control Management
-  Shortage Management
-  Alternative Solution
-  Excess Inventory Management