

Voltage Protection with Automatic Cell Balance for 2-Series Cell Li-Ion Batteries

Check for Samples: [bq29200](#) , [bq29209](#)

FEATURES

- 2-Series Cell Secondary Protection
- Automatic Cell Imbalance Correction with External Enable Control
 - ± 30 mV Enable, 0 mV Disable Thresholds Typical
- External Capacitor-Controlled Delay Timer
- External Resistor-Controlled Cell Balance Current
- Low Power Consumption $I_{CC} < 3 \mu\text{A}$ Typical ($V_{\text{CELL(ALL)}} < V_{\text{PROTECT}}$)
- Internal Cell Balancing Handles Current up to 15 mA

- External Cell Balancing Mode Supported
- High-Accuracy Overvoltage Protection:
 - ± 25 mV with $T_A = 0^\circ\text{C}$ to 60°C
- Fixed Overvoltage Protection Thresholds: 4.30 V, 4.35 V
- Small 8L DRB Package

APPLICATIONS

- 2nd Level Protection in Li-Ion Battery Packs
 - Netbook Computers
 - Power Tools
 - Portable Equipment and Instrumentation
 - Battery Backup Systems

DESCRIPTION

The bq2920x device is a secondary overvoltage protection IC for 2-series cell lithium-ion battery packs that incorporates a high-accuracy precision overvoltage detection circuit and automatic cell imbalance correction.

The voltage of each cell in a 2-series cell battery pack is compared to an internal reference voltage. If either cell reaches an overvoltage condition, the bq2920x device starts a timer that provides a delay proportional to the capacitance on the CD pin. Upon expiration of the internal timer, the OUT pin changes from low to high state.

If enabled, the bq2920x performs automatic cell imbalance correction where the two cells are automatically corrected for voltage imbalance by loading the cell with the higher charge voltage with a small balancing current. When the cells are measured to be equal within nominally 0 mV, the load current is removed. It will be re-applied if the imbalance exceeds nominally 30 mV. The cell mismatch correction circuitry is enabled by pulling the CB_EN pin low, and disabled when CB_EN is pulled to VDD or greater than 2.2 V.

If the internal cell balancing current of up to 15 mA is insufficient, the bq2920x may be configured via external circuitry to support much higher external cell balancing current.

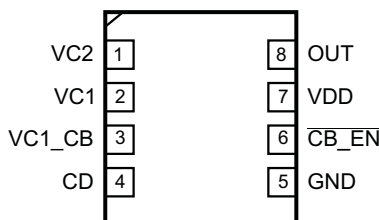

Please be aware that an important notice concerning availability, standard warranty, and use in critical applications of Texas Instruments semiconductor products and disclaimers thereto appears at the end of this data sheet.



These devices have limited built-in ESD protection. The leads should be shorted together or the device placed in conductive foam during storage or handling to prevent electrostatic damage to the MOS gates.

ORDERING INFORMATION

T _A	PART NUMBER	PACKAGE	PACKAGE DESIGNATOR	PACKAGE MARKING	OVP	ORDERING INFORMATION	
						TAPE AND REEL (LARGE)	TAPE AND REEL (SMALL)
-40°C to +110°C	BQ29200	QFN-8	DRB	200	4.35 V	BQ29200DRBR	BQ29209DRBT
	BQ29209			209	4.30 V	BQ29209DRBR	BQ29209DRBT

THERMAL INFORMATION

THERMAL METRIC ⁽¹⁾		bq2920x	UNITS
		DRB	
		8 PINS	
θ_{JA}	Junction-to-ambient thermal resistance ⁽²⁾	50.5	°C/W
$\theta_{JC(top)}$	Junction-to-case(top) thermal resistance ⁽³⁾	25.1	
θ_{JB}	Junction-to-board thermal resistance ⁽⁴⁾	19.3	
ψ_{JT}	Junction-to-top characterization parameter ⁽⁵⁾	0.7	
ψ_{JB}	Junction-to-board characterization parameter ⁽⁶⁾	18.9	
$\theta_{JC(bottom)}$	Junction-to-case(bottom) thermal resistance ⁽⁷⁾	5.2	

- (1) For more information about traditional and new thermal metrics, see the *IC Package Thermal Metrics* application report, [SPRA953](#).
- (2) The junction-to-ambient thermal resistance under natural convection is obtained in a simulation on a JEDEC-standard, high-K board, as specified in JESD51-7, in an environment described in JESD51-2a.
- (3) The junction-to-case (top) thermal resistance is obtained by simulating a cold plate test on the package top. No specific JEDEC-standard test exists, but a close description can be found in the ANSI SEMI standard G30-88.
- (4) The junction-to-board thermal resistance is obtained by simulating in an environment with a ring cold plate fixture to control the PCB temperature, as described in JESD51-8.
- (5) The junction-to-top characterization parameter, ψ_{JT} , estimates the junction temperature of a device in a real system and is extracted from the simulation data for obtaining θ_{JA} , using a procedure described in JESD51-2a (sections 6 and 7).
- (6) The junction-to-board characterization parameter, ψ_{JB} , estimates the junction temperature of a device in a real system and is extracted from the simulation data for obtaining θ_{JA} , using a procedure described in JESD51-2a (sections 6 and 7).
- (7) The junction-to-case (bottom) thermal resistance is obtained by simulating a cold plate test on the exposed (power) pad. No specific JEDEC standard test exists, but a close description can be found in the ANSI SEMI standard G30-88.

PIN FUNCTIONS

PIN NAME	NO.	DESCRIPTION
$\overline{CB_EN}$	6	Cell balance enable
CD	4	Connection to external capacitor for programmable delay time
GND	5	Ground pin
OUT	8	Output
VC1	2	Sense voltage input for bottom cell
VC1_CB	3	Cell balance input for bottom cell
VC2	1	Sense voltage input for top cell
VDD	7	Power supply

FUNCTIONAL BLOCK DIAGRAM

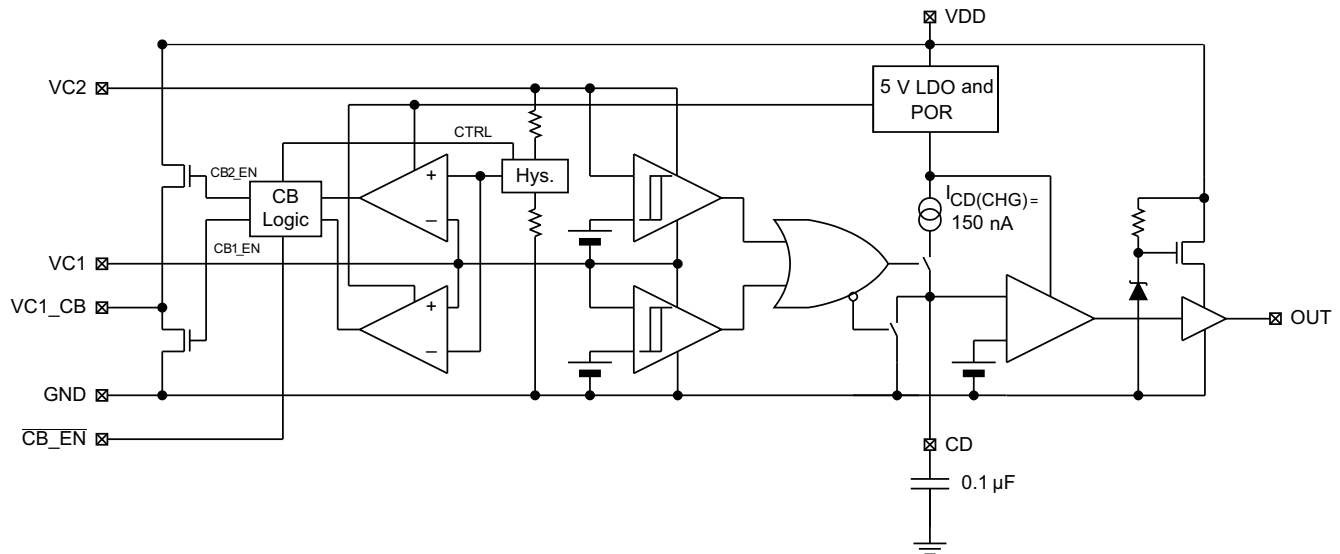

Figure 1. Block Diagram

ABSOLUTE MAXIMUM RATINGS

Over-operating free-air temperature range (unless otherwise noted)⁽¹⁾

		VALUE/UNIT
Supply voltage range, V_{MAX}	VDD–GND	–0.3 V to 16 V
Input voltage range, V_{IN}	VC2–GND, VC1–GND	–0.3 V to 16 V
	VC2–VC1, CD–GND	–0.3 V to 8 V
	$\overline{CB_EN}$ –GND	–0.3 V to 16 V
Output voltage range, V_{OUT}	OUT–GND	–0.3 V to 16 V
Continuous total power dissipation, P_{TOT}		See package dissipation rating
Storage temperature range, T_{STG}		–65°C to 150°C
Lead temperature (soldering, 10 s), T_{SOLDER}		300°C

(1) Stresses beyond those listed under “absolute maximum ratings” may cause permanent damage to the device. These are stress ratings only and functional operation of the device at these or any other conditions beyond those indicated under “recommended operating conditions” is not implied. Exposure to absolute–maximum–rated conditions for extended periods may affect device reliability.

RECOMMENDED OPERATING CONDITIONS

		MIN	NOM	MAX	UNIT
Supply voltage, VDD		4		10	V
Input voltage range	VC2–VC1, VC1–GND	0		5	V
Delay time capacitance, $t_d(CD)$	C_{CD} (See Figure 8.)		0.1		μF
Voltage monitor filter resistance	R_{IN} (See Figure 8.)	100	1K		Ω
Voltage monitor filter capacitance	C_{IN} (See Figure 8.)	0.01	0.1		μF
Supply voltage filter resistance	R_{VD} (See Figure 8.)		100	1K	Ω
Supply voltage filter capacitance	C_{VD} (See Figure 8.)		0.1		μF
Cell balance resistance	R_{CB} (See Figure 8 and PROTECTION (OUT) TIMING.)	100		4.7K	Ω
Operating ambient temperature range, T_A		–40		110	°C

ELECTRICAL CHARACTERISTICS

Typical values stated where $T_A = 25^\circ\text{C}$ and $V_{DD} = 7.2\text{ V}$. Min/Max values stated where $T_A = -40^\circ\text{C}$ to 110°C and $V_{DD} = 4\text{ V}$ to 10 V (unless otherwise noted).

PARAMETER		TEST CONDITION	MIN	NOM	MAX	UNIT
V_{PROTECT}	Overvoltage detection voltage	bq29209	4.30			V
		bq29200	4.35			
V_{HYS}	Overvoltage detection hysteresis		200	300	400	mV
V_{OA}	Overvoltage detection accuracy	$T_A = 25^\circ\text{C}$	-10		10	mV
$V_{\text{OA_DRIFT}}$	Overvoltage threshold temperature drift	$T_A = 0^\circ\text{C}$ to 60°C	-0.4		0.4	mV $^\circ\text{C}$
		$T_A = -40^\circ\text{C}$ to 110°C	-0.6		0.6	
X_{DELAY}	Overvoltage delay time scale factor	$T_A = 0^\circ\text{C}$ to 60°C Note: Does not include external capacitor variation.	6.0	9.0	12.0	s/ μF
		$T_A = -40^\circ\text{C}$ to 110°C Note: Does not include external capacitor variation.	5.5	9.0	13.5	
$X_{\text{DELAY_CTM}}^{(1)}$	Overvoltage delay time scale factor in Customer Test Mode		0.08			s/ μF
$I_{\text{CD(CHG)}}$	Overvoltage detection charging current		150			nA
$I_{\text{CD(DSG)}}$	Overvoltage detection discharging current		60			μA
V_{CD}	Overvoltage detection external capacitor comparator threshold		1.2			V
I_{CC}	Supply current	$(V_{\text{C2}} - V_{\text{C1}}) = (V_{\text{C1}} - \text{GND}) = 3.5\text{ V}$ (See Figure 4.)	3.0	6.0		μA
V_{OUT}	OUT pin drive voltage	$(V_{\text{C2}} - V_{\text{C1}})$ or $(V_{\text{C1}} - \text{GND}) > V_{\text{PROTECT}}$, $V_{\text{DD}} = 10\text{ V}$, $I_{\text{OH}} = 0$	6	8.25	9.5	V
		$(V_{\text{C2}} - V_{\text{C1}})$ or $(V_{\text{C1}} - \text{GND}) = V_{\text{PROTECT}}$, $V_{\text{DD}} = V_{\text{PROTECT}}$, $I_{\text{OH}} = -100\ \mu\text{A}$, $T_A = 0^\circ\text{C}$ to 60°C	1.75	2.5		V
		$(V_{\text{C2}} - V_{\text{C1}})$ and $(V_{\text{C1}} - \text{GND}) < V_{\text{PROTECT}}$, $I_{\text{OL}} = 100\ \mu\text{A}$, $T_A = 25^\circ\text{C}$			200	mV
		$(V_{\text{C2}} - V_{\text{C1}})$ and $(V_{\text{C1}} - \text{GND}) < V_{\text{PROTECT}}$, $I_{\text{OL}} = 0\ \mu\text{A}$, $T_A = 25^\circ\text{C}$		0	10	mV
		$V_{\text{C2}} = V_{\text{C1}} = V_{\text{DD}} = 4\text{ V}$, $I_{\text{OL}} = 100\ \mu\text{A}$			200	mV
I_{OH}	High-level output current	OUT = 1.75 V, $(V_{\text{C2}} - V_{\text{C1}})$ or $(V_{\text{C1}} - \text{GND}) = V_{\text{PROTECT}}$, $V_{\text{DD}} = V_{\text{PROTECT}}$ to 10 V , $T_A = 0^\circ\text{C}$ to 60°C	-100			μA
I_{OL}	Low-level output current	OUT = 0.05 V, $(V_{\text{C2}} - V_{\text{C1}})$ or $(V_{\text{C1}} - \text{GND}) < V_{\text{PROTECT}}$, $V_{\text{DD}} = V_{\text{PROTECT}}$ to 10 V , $T_A = 0^\circ\text{C}$ to 60°C	30		85	μA
$I_{\text{OH_ZV}}$	High-level short-circuit output current	OUT = 0 V, $(V_{\text{C2}} - V_{\text{C1}}) = (V_{\text{C1}} - \text{GND}) = V_{\text{PROTECT}}$ $V_{\text{DD}} = 4$ to 10 V			-8.0	mA
I_{IN}	Input current at VCx pins	Measured at VC1, $(V_{\text{C2}} - V_{\text{C1}}) = (V_{\text{C1}} - \text{GND}) = 3.5\text{ V}$, $T_A = 0^\circ\text{C}$ to 60°C (See Figure 4.)	-0.2		0.2	μA
		Measured at VC2, $(V_{\text{C2}} - V_{\text{C1}}) = (V_{\text{C1}} - \text{GND}) = 3.5\text{ V}$, $T_A = 0^\circ\text{C}$ to 60°C (See Figure 4.)			2.5	μA
$V_{\text{MM_DET_ON}}$	Cell mismatch detection threshold for turning ON	$(V_{\text{C2}} - V_{\text{C1}})$ versus $(V_{\text{C1}} - \text{GND})$ and vice-versa when cell balancing is enabled. $V_{\text{C2}} = V_{\text{DD}} = 7.6\text{ V}$	17	30	45	mV
$V_{\text{MM_DET_OFF}}$	Cell mismatch detection threshold for turning OFF	Delta between $(V_{\text{C2}} - V_{\text{C1}})$ and $(V_{\text{C1}} - \text{GND})$ when cell balancing is disabled. $V_{\text{C2}} = V_{\text{DD}} = 7.6\text{ V}$	-9	0	9	mV
$V_{\text{CB_EN_ON}}$	Cell balance enable ON threshold	Active LOW pin at $\overline{\text{CB_EN}}$			1	V
$V_{\text{CB_EN_OFF}}$	Cell balance enable OFF threshold	Active HIGH at $\overline{\text{CB_EN}}$	2.2			V
$I_{\text{CB_EN}}$	Cell balance enable ON input current	$\overline{\text{CB_EN}} = \text{GND}$ (See Figure 5.)			0.2	μA

(1) Specified by design. Not 100% tested in production.

RECOMMENDED CELL BALANCING CONFIGURATIONS

Typical values stated where $T_A = 25^\circ\text{C}$ and $(VC2-VC1)$, $(VC1-GND) = 3.8\text{ V}$. Min/Max values stated where $T_A = -40^\circ\text{C}$ to 110°C , $VDD = 4\text{ V}$ to 10 V , and $(VC2-VC1)$, $(VC1-GND) = 3.0\text{ V}$ to 4.2 V . All values assume recommended supply voltage filter resistance R_{VD} of $100\ \Omega$ and 5% accurate or better cell balance resistor R_{CB} .

PARAMETER	TEST CONDITION	MIN	NOM	MAX	UNIT
I_{CB} Cell balance input current	$R_{CB} = 4700\ \Omega$	0.5	0.75	1	mA
	$R_{CB} = 2200\ \Omega$	1	1.5	2	
	$R_{CB} = 910\ \Omega$	2	3	4	
	$R_{CB} = 560\ \Omega$	3	4.5	6	
	$R_{CB} = 360\ \Omega$	3.5	6	8.5	
	$R_{CB} = 240\ \Omega$	4	7.5	11	
	$R_{CB} = 120\ \Omega$	5	10	15	

The cell balancing current may be calculated as follows:

Cell 1 (VC1-GND):

$$I_{CB1} = \frac{VC1}{R_{CB}}$$

Cell 2 (VC2-VC1):

$$I_{CB2} = \frac{(VC2 - VC1)}{(R_{CB} + R_{VD})}$$

TYPICAL CHARACTERISTICS

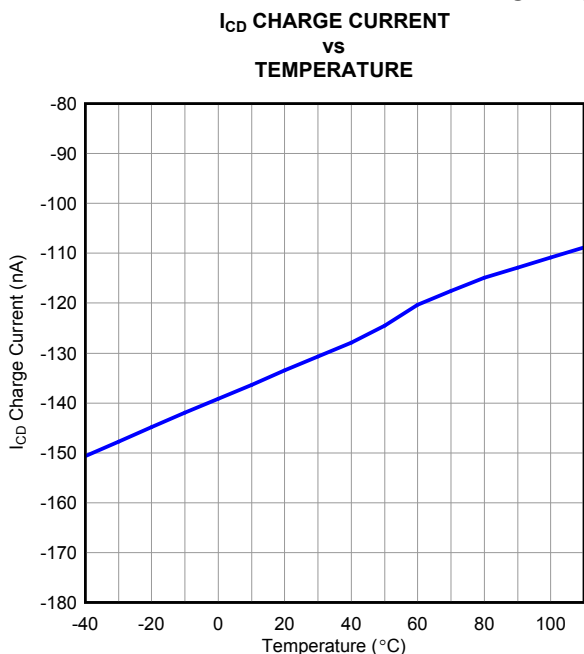

Figure 2. I_{CD} Charge Current

G001

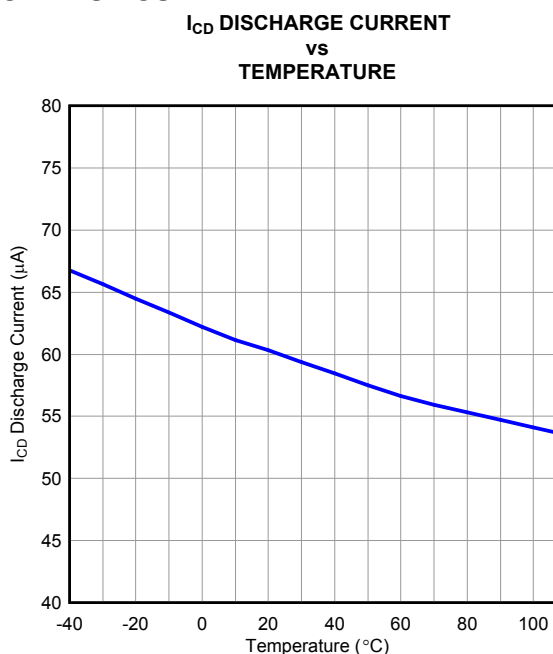

Figure 3. I_{CD} Discharge Current

G002

TEST CONDITIONS

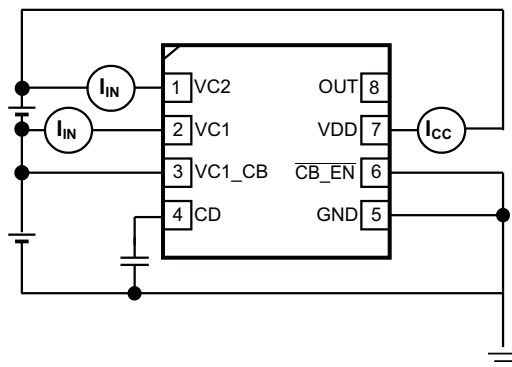

Figure 4. I_{CC} , I_{IN} Measurement

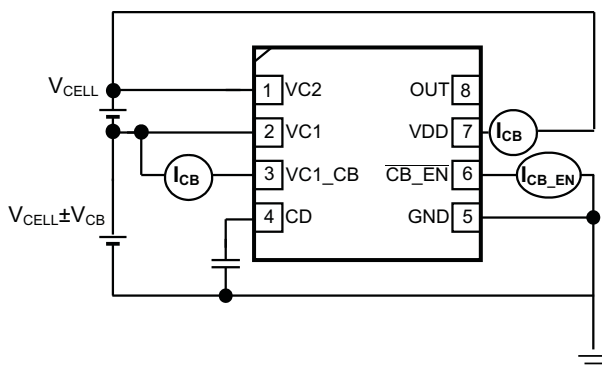

Figure 5. I_{CB} Measurement

PROTECTION (OUT) TIMING

Sizing the external capacitor is based on the desired delay time as follows:

$$C_{CD} = \frac{t_d}{X_{DELAY}}$$

Where t_d is the desired delay time and X_{DELAY} is the overvoltage delay time scale factor, expressed in seconds per microFarad. X_{DELAY} is nominally 9.0 s/ μ F. For example, if a nominal delay of 3 seconds is desired, use a C_{CD} capacitor that is 3 s / 9.0 s/ μ F = 0.33 μ F.

The delay time is calculated as follows:

$$t_d = C_{CD} \times X_{DELAY}$$

If the cell overvoltage condition is removed before the external capacitor reaches the reference voltage, the internal current source is disabled and an internal discharge block is employed to discharge the external capacitor down to 0 V. In this instance, the OUT pin remains in a low state.

Cell Voltage > $V_{PROTECT}$

When one or both of the cell voltages rises above $V_{PROTECT}$, the internal comparator is tripped, and the delay begins to count to t_d . If the input remains above $V_{PROTECT}$ for the duration of t_d , the bq2920x output changes from a low to a high state, by means of an internal pull-up network, to a regulated voltage of no more than 9.5 V when $I_{OH} = 0$ mA.

The external delay capacitor should charge up to no more than the internal LDO voltage (approximately 5 V typically), and will fully discharge in approximately under 100 ms when the overvoltage condition is removed.

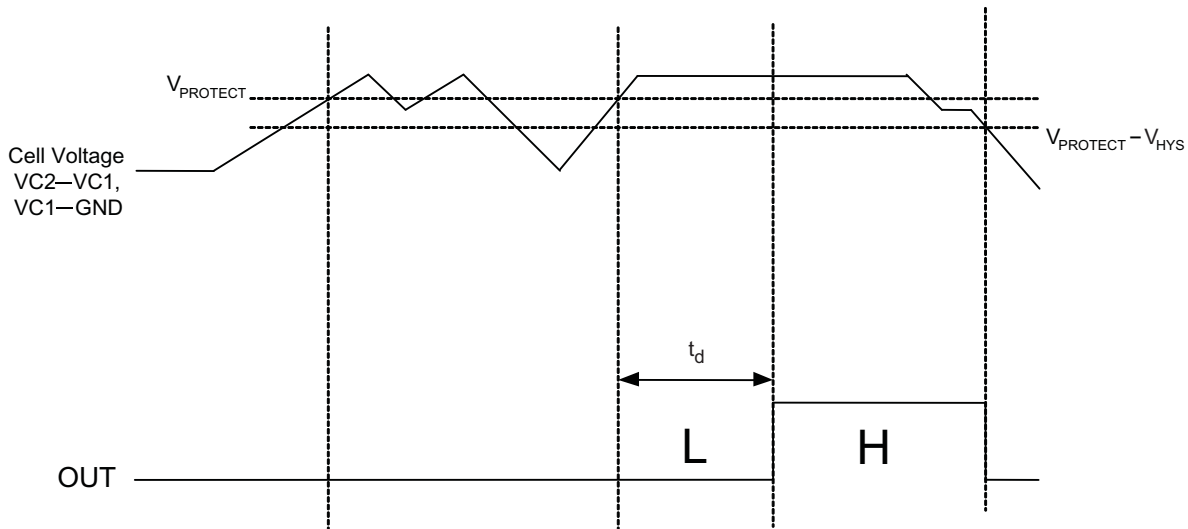

Figure 6. Timing for Overvoltage Sensing

CELL CONNECTION SEQUENCE

NOTE

Before connecting the cells, propagate the overvoltage delay timing capacitor, C_{CD} .

The recommended cell connection sequence begins from the bottom of the stack, as follows:

1. GND
2. VC1
3. VC2

While not advised, connecting the cells in a sequence other than that described above does not result in errant activity on the OUT pin. For example:

1. GND
2. VC2 or VC1
3. Remaining VCx pin

CELL BALANCE ENABLE CONTROL

To avoid prematurely discharging the cells, it is recommended to turn off (pull high) the active-low Cell Balance Enable Control pin at lower State of Charge (SOC) levels.

CELL IMBALANCE AUTO-DETECTION (VIA CELL VOLTAGE)

The $V_{MM_DET_ON}$ and $V_{MM_DET_OFF}$ specifications are calibrated where $VDD = VC2 = 7.6$ V and $VC1 = 3.8$ V. The recommended range of cell balancing is $VC2$ and VDD between 6.0 V and 8.4 V, and $VC1$ between 3.0 V and 4.2 V. Below $VDD = 6.0$ V, it is recommended to pull CB_EN high to disable the cell balancing function.

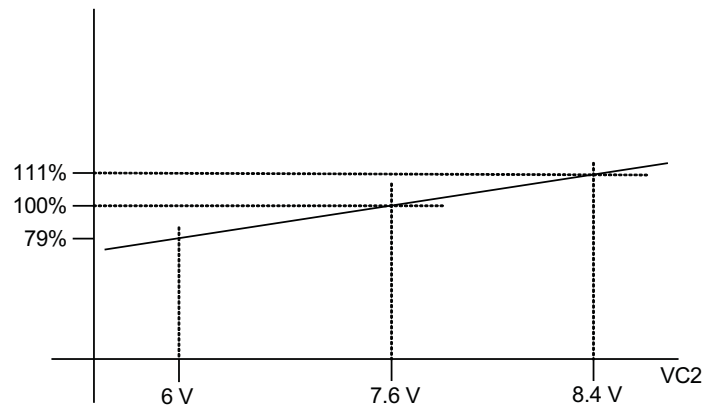

Figure 7. $V_{MM_DET_ON}$ and $V_{MM_DET_OFF}$ Threshold

BATTERY CONNECTION

Figure 8 shows the configuration for the 2-series cell battery connection.

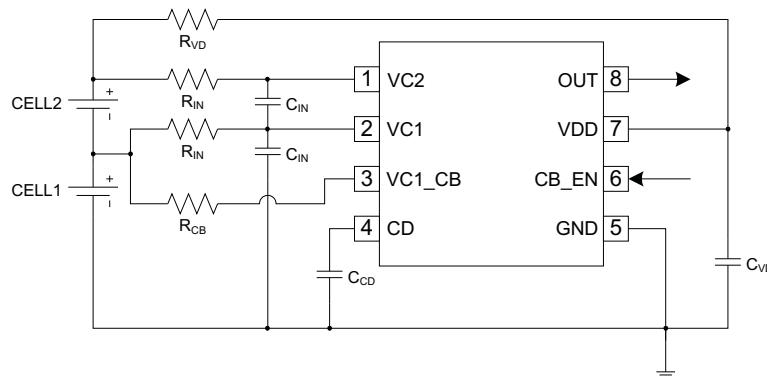

Figure 8. 2-Series Cell Configuration

EXTERNAL CELL BALANCING

Higher cell balancing currents can be supported by means of a simple external network, as shown in Figure 9.

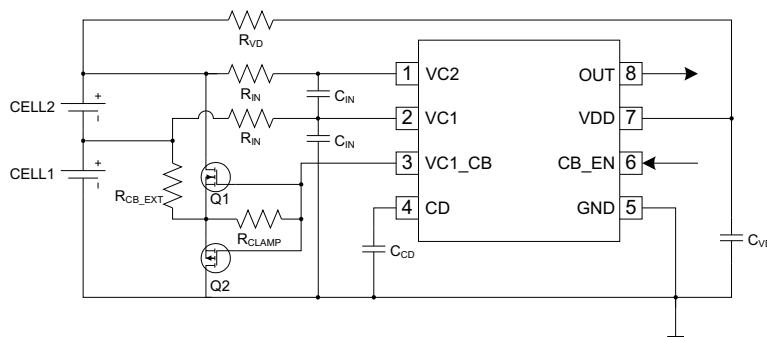

Figure 9. External Cell Balancing Configuration

R_{CLAMP} ensures that both Q1 and Q2 remain off when balancing is disabled, and should be sized above 2 k Ω to prevent excessive internal device current when the balancing network is activated. R_{CB_EXT} determines the value of the balancing current, and is dependent on the voltage of the balanced cell, as follows:

$$I_{bal} = \frac{V_{CELL}}{R_{CB_EXT}}$$

CUSTOMER TEST MODE

Customer Test Mode (CTM) helps to greatly reduce the overvoltage detection delay time and enable quicker customer production testing. This mode is intended for quick-pass board-level verification tests, and, as such, individual cell overvoltage levels may deviate slightly from the specifications ($V_{PROTECT}$, V_{OA}). If accurate overvoltage thresholds are to be tested, use the standard delay settings that are intended for normal use.

To enter CTM, VDD should be set to approximately 9.5 V higher than VC2. When CTM is entered, the device switches from the normal overvoltage delay time scale factor, X_{DELAY} , to a significantly reduced factor of approximately 0.08, thereby reducing the delay time during an overvoltage condition.

CAUTION

Avoid exceeding any Absolute Maximum Voltages on any pins when placing the part into CTM. Also, avoid exceeding Absolute Maximum Voltages for the individual cell voltages (VC1–GND) and (VC2–VC1). Stressing the pins beyond the rated limits may cause permanent damage to the device.

To exit CTM, power off the device and then power it back on.

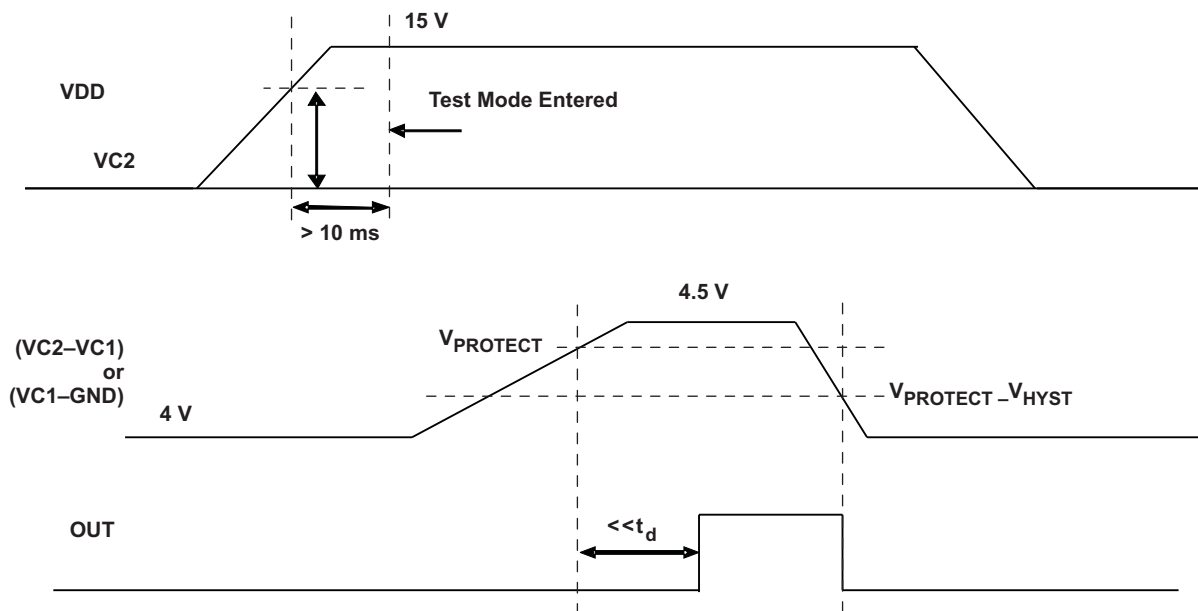

Figure 10. Voltage Test Limits

REVISION HISTORY

Changes from Original (June 2010) to Revision A	Page
• Changed values in X_{DELAY} and $X_{\text{DELAY_CTM}}$ electrical characteristics	4
• Changed specifications for V_{OUT}	4
• Changed test conditions for V_{OUT} , I_{OH} , and I_{OL}	4
• Added $V_{\text{MM_DET_ON}}$: $VC2 = VDD = 7.6 \text{ V}$	4
• Changed $V_{\text{MM_DET_OFF}}$: From $VDD - VC2 - 7.6 \text{ V}$ to $VC2 = VDD = 7.6 \text{ V}$	4
• Changed content in Recommended Cell Balancing Configurations section	5
• Added I_{CD} Charge Current figure	5
• Added I_{CD} Discharge Current figure	5
• Changed X_{DELAY} from nominally 8.0 s/ μF to nominally 9.0 s/ μF	6
• Changed Timing for Overvoltage Sensing figure	6
• Added Cell Imbalance Auto-Detection (Via Cell Voltage) section	7
• Added External Cell Balancing section	8
• Changed VDD value in Customer Test Mode from 8.5 V to 9.5 V	9
• Changed the Voltage Test Limits figure	9

PACKAGING INFORMATION

Orderable Device	Status ⁽¹⁾	Package Type	Package Drawing	Pins	Package Qty	Eco Plan ⁽²⁾	Lead/ Ball Finish	MSL Peak Temp ⁽³⁾	Samples (Requires Login)
BQ29200DRBR	ACTIVE	SON	DRB	8	3000	Green (RoHS & no Sb/Br)	CU NIPDAU	Level-2-260C-1 YEAR	
BQ29200DRBT	ACTIVE	SON	DRB	8	250	Green (RoHS & no Sb/Br)	CU NIPDAU	Level-2-260C-1 YEAR	
BQ29209DRBR	ACTIVE	SON	DRB	8	3000	Green (RoHS & no Sb/Br)	CU NIPDAU	Level-2-260C-1 YEAR	
BQ29209DRBT	ACTIVE	SON	DRB	8	250	Green (RoHS & no Sb/Br)	CU NIPDAU	Level-2-260C-1 YEAR	

⁽¹⁾ The marketing status values are defined as follows:

ACTIVE: Product device recommended for new designs.

LIFEBUY: TI has announced that the device will be discontinued, and a lifetime-buy period is in effect.

NRND: Not recommended for new designs. Device is in production to support existing customers, but TI does not recommend using this part in a new design.

PREVIEW: Device has been announced but is not in production. Samples may or may not be available.

OBSELETE: TI has discontinued the production of the device.

⁽²⁾ Eco Plan - The planned eco-friendly classification: Pb-Free (RoHS), Pb-Free (RoHS Exempt), or Green (RoHS & no Sb/Br) - please check <http://www.ti.com/productcontent> for the latest availability information and additional product content details.

TBD: The Pb-Free/Green conversion plan has not been defined.

Pb-Free (RoHS): TI's terms "Lead-Free" or "Pb-Free" mean semiconductor products that are compatible with the current RoHS requirements for all 6 substances, including the requirement that lead not exceed 0.1% by weight in homogeneous materials. Where designed to be soldered at high temperatures, TI Pb-Free products are suitable for use in specified lead-free processes.

Pb-Free (RoHS Exempt): This component has a RoHS exemption for either 1) lead-based flip-chip solder bumps used between the die and package, or 2) lead-based die adhesive used between the die and leadframe. The component is otherwise considered Pb-Free (RoHS compatible) as defined above.

Green (RoHS & no Sb/Br): TI defines "Green" to mean Pb-Free (RoHS compatible), and free of Bromine (Br) and Antimony (Sb) based flame retardants (Br or Sb do not exceed 0.1% by weight in homogeneous material)

⁽³⁾ MSL, Peak Temp. -- The Moisture Sensitivity Level rating according to the JEDEC industry standard classifications, and peak solder temperature.

Important Information and Disclaimer: The information provided on this page represents TI's knowledge and belief as of the date that it is provided. TI bases its knowledge and belief on information provided by third parties, and makes no representation or warranty as to the accuracy of such information. Efforts are underway to better integrate information from third parties. TI has taken and continues to take reasonable steps to provide representative and accurate information but may not have conducted destructive testing or chemical analysis on incoming materials and chemicals. TI and TI suppliers consider certain information to be proprietary, and thus CAS numbers and other limited information may not be available for release.

In no event shall TI's liability arising out of such information exceed the total purchase price of the TI part(s) at issue in this document sold by TI to Customer on an annual basis.

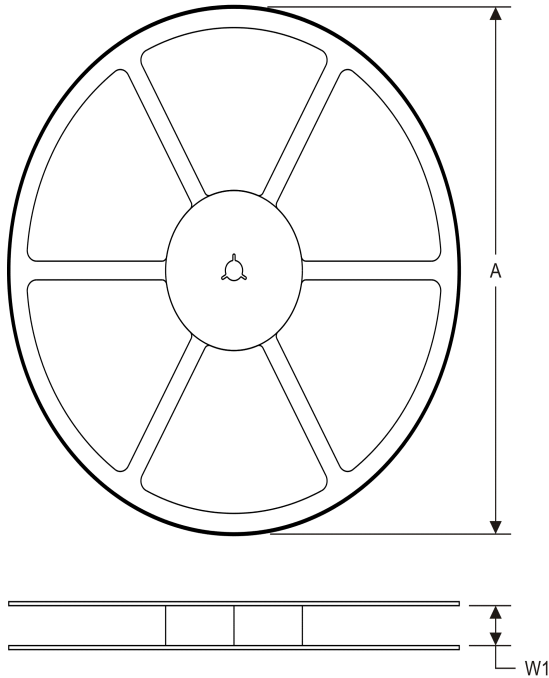
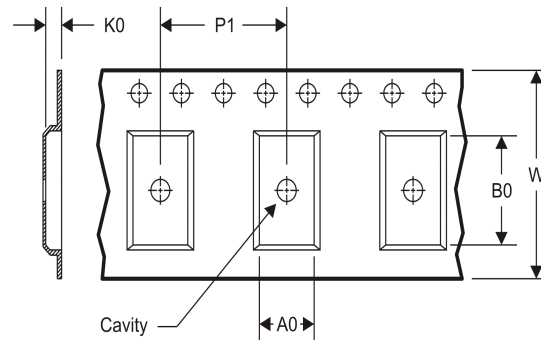
TAPE AND REEL INFORMATION
REEL DIMENSIONS

TAPE DIMENSIONS

A0	Dimension designed to accommodate the component width
B0	Dimension designed to accommodate the component length
K0	Dimension designed to accommodate the component thickness
W	Overall width of the carrier tape
P1	Pitch between successive cavity centers

TAPE AND REEL INFORMATION

*All dimensions are nominal

Device	Package Type	Package Drawing	Pins	SPQ	Reel Diameter (mm)	Reel Width W1 (mm)	A0 (mm)	B0 (mm)	K0 (mm)	P1 (mm)	W (mm)	Pin1 Quadrant
BQ29200DRBR	SON	DRB	8	3000	330.0	12.4	3.3	3.3	1.1	8.0	12.0	Q2
BQ29200DRBT	SON	DRB	8	250	180.0	12.4	3.3	3.3	1.1	8.0	12.0	Q2
BQ29209DRBR	SON	DRB	8	3000	330.0	12.4	3.3	3.3	1.1	8.0	12.0	Q2
BQ29209DRBT	SON	DRB	8	250	180.0	12.4	3.3	3.3	1.1	8.0	12.0	Q2

TAPE AND REEL BOX DIMENSIONS

*All dimensions are nominal

Device	Package Type	Package Drawing	Pins	SPQ	Length (mm)	Width (mm)	Height (mm)
BQ29200DRBR	SON	DRB	8	3000	367.0	367.0	35.0
BQ29200DRBT	SON	DRB	8	250	210.0	185.0	35.0
BQ29209DRBR	SON	DRB	8	3000	367.0	367.0	35.0
BQ29209DRBT	SON	DRB	8	250	210.0	185.0	35.0

DRB (S-PVSON-N8)

PLASTIC SMALL OUTLINE NO-LEAD

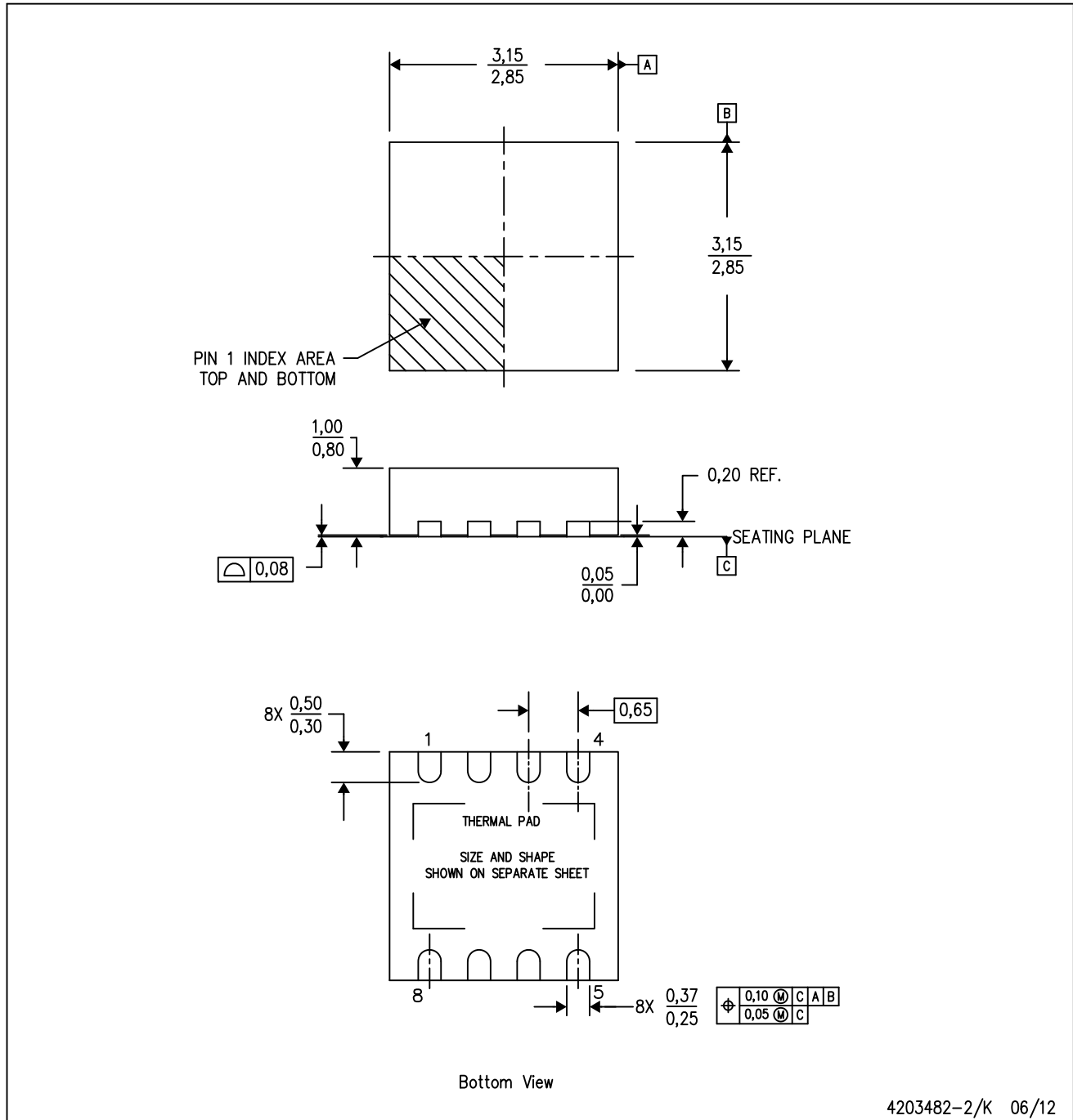

- NOTES:
- All linear dimensions are in millimeters. Dimensioning and tolerancing per ASME Y14.5M-1994.
 - This drawing is subject to change without notice.
 - Small Outline No-Lead (SON) package configuration.
 - The package thermal pad must be soldered to the board for thermal and mechanical performance.
 - See the additional figure in the Product Data Sheet for details regarding the exposed thermal pad features and dimensions.

THERMAL PAD MECHANICAL DATA

DRB (S-PVSON-N8)

PLASTIC SMALL OUTLINE NO-LEAD

THERMAL INFORMATION

This package incorporates an exposed thermal pad that is designed to be attached directly to an external heatsink. The thermal pad must be soldered directly to the printed circuit board (PCB). After soldering, the PCB can be used as a heatsink. In addition, through the use of thermal vias, the thermal pad can be attached directly to the appropriate copper plane shown in the electrical schematic for the device, or alternatively, can be attached to a special heatsink structure designed into the PCB. This design optimizes the heat transfer from the integrated circuit (IC).

For information on the Quad Flatpack No-Lead (QFN) package and its advantages, refer to Application Report, QFN/SON PCB Attachment, Texas Instruments Literature No. SLUA271. This document is available at www.ti.com.

The exposed thermal pad dimensions for this package are shown in the following illustration.

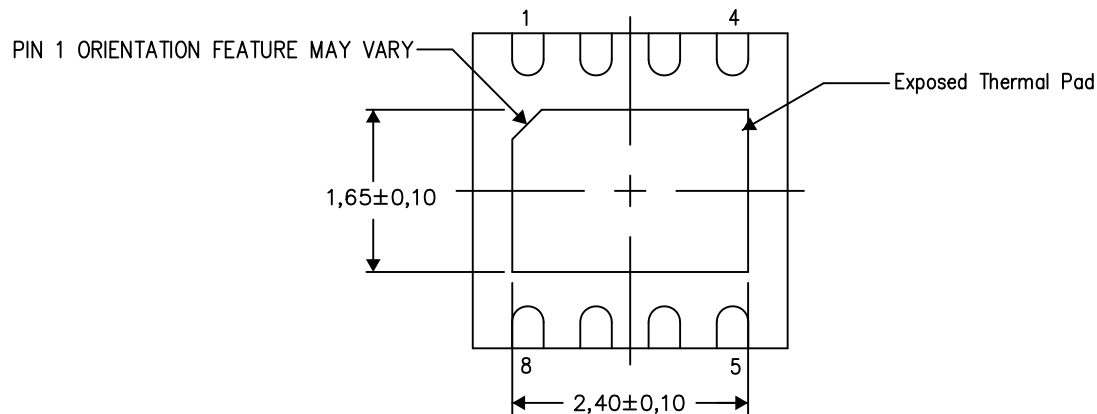

Bottom View

Exposed Thermal Pad Dimensions

4206340-3/M 06/12

NOTE: All linear dimensions are in millimeters

IMPORTANT NOTICE

Texas Instruments Incorporated and its subsidiaries (TI) reserve the right to make corrections, enhancements, improvements and other changes to its semiconductor products and services per JESD46C and to discontinue any product or service per JESD48B. Buyers should obtain the latest relevant information before placing orders and should verify that such information is current and complete. All semiconductor products (also referred to herein as "components") are sold subject to TI's terms and conditions of sale supplied at the time of order acknowledgment.

TI warrants performance of its components to the specifications applicable at the time of sale, in accordance with the warranty in TI's terms and conditions of sale of semiconductor products. Testing and other quality control techniques are used to the extent TI deems necessary to support this warranty. Except where mandated by applicable law, testing of all parameters of each component is not necessarily performed.

TI assumes no liability for applications assistance or the design of Buyers' products. Buyers are responsible for their products and applications using TI components. To minimize the risks associated with Buyers' products and applications, Buyers should provide adequate design and operating safeguards.

TI does not warrant or represent that any license, either express or implied, is granted under any patent right, copyright, mask work right, or other intellectual property right relating to any combination, machine, or process in which TI components or services are used. Information published by TI regarding third-party products or services does not constitute a license to use such products or services or a warranty or endorsement thereof. Use of such information may require a license from a third party under the patents or other intellectual property of the third party, or a license from TI under the patents or other intellectual property of TI.

Reproduction of significant portions of TI information in TI data books or data sheets is permissible only if reproduction is without alteration and is accompanied by all associated warranties, conditions, limitations, and notices. TI is not responsible or liable for such altered documentation. Information of third parties may be subject to additional restrictions.

Resale of TI components or services with statements different from or beyond the parameters stated by TI for that component or service voids all express and any implied warranties for the associated TI component or service and is an unfair and deceptive business practice. TI is not responsible or liable for any such statements.

Buyer acknowledges and agrees that it is solely responsible for compliance with all legal, regulatory and safety-related requirements concerning its products, and any use of TI components in its applications, notwithstanding any applications-related information or support that may be provided by TI. Buyer represents and agrees that it has all the necessary expertise to create and implement safeguards which anticipate dangerous consequences of failures, monitor failures and their consequences, lessen the likelihood of failures that might cause harm and take appropriate remedial actions. Buyer will fully indemnify TI and its representatives against any damages arising out of the use of any TI components in safety-critical applications.

In some cases, TI components may be promoted specifically to facilitate safety-related applications. With such components, TI's goal is to help enable customers to design and create their own end-product solutions that meet applicable functional safety standards and requirements. Nonetheless, such components are subject to these terms.

No TI components are authorized for use in FDA Class III (or similar life-critical medical equipment) unless authorized officers of the parties have executed a special agreement specifically governing such use.

Only those TI components which TI has specifically designated as military grade or "enhanced plastic" are designed and intended for use in military/aerospace applications or environments. Buyer acknowledges and agrees that any military or aerospace use of TI components which have **not** been so designated is solely at the Buyer's risk, and that Buyer is solely responsible for compliance with all legal and regulatory requirements in connection with such use.

TI has specifically designated certain components which meet ISO/TS16949 requirements, mainly for automotive use. Components which have not been so designated are neither designed nor intended for automotive use; and TI will not be responsible for any failure of such components to meet such requirements.

Products

Audio	www.ti.com/audio
Amplifiers	amplifier.ti.com
Data Converters	dataconverter.ti.com
DLP® Products	www.dlp.com
DSP	dsp.ti.com
Clocks and Timers	www.ti.com/clocks
Interface	interface.ti.com
Logic	logic.ti.com
Power Mgmt	power.ti.com
Microcontrollers	microcontroller.ti.com
RFID	www.ti-rfid.com
OMAP Mobile Processors	www.ti.com/omap
Wireless Connectivity	www.ti.com/wirelessconnectivity

Applications

Automotive and Transportation	www.ti.com/automotive
Communications and Telecom	www.ti.com/communications
Computers and Peripherals	www.ti.com/computers
Consumer Electronics	www.ti.com/consumer-apps
Energy and Lighting	www.ti.com/energy
Industrial	www.ti.com/industrial
Medical	www.ti.com/medical
Security	www.ti.com/security
Space, Avionics and Defense	www.ti.com/space-avionics-defense
Video and Imaging	www.ti.com/video

TI E2E Community e2e.ti.com

Looking for pricing, stock, or lifecycle information?

Click below to explore more details on WIN SOURCE:

 [View BQ29200DRBR](#) on WIN SOURCE

 [Texas Instruments](#) Information

Optimize Your Supply Chain with WIN SOURCE Solutions

-  Global Sourcing Solution
-  Obsolete Management
-  Cost Control Management
-  Shortage Management
-  Alternative Solution
-  Excess Inventory Management