



**THE DATASHEET OF
BQ27520YZFT-G4**

bq27520-G4 System-Side Impedance Track™ Fuel Gauge With Integrated LDO

1 Features

- Single-Series Cell Li-Ion Battery Fuel Gauge Resides on System Board
 - Integrated 2.5 VDC LDO
 - External Low-Value 10-mΩ Sense Resistor
- Patented Impedance Track™ Technology
 - Adjusts for Battery Aging, Self-Discharge, Temperature, and Rate Changes
 - Reports Remaining Capacity, State-of-Charge (SOC), and Time-to-Empty
 - Optional Smoothing Filter
 - Battery State-of-Health (Aging) Estimation
 - Supports Embedded or Removable Packs with up to 32A hr Capacity
 - Accommodates Pack Swapping With 2 Separate Battery Profiles
- Microcontroller Peripheral Supports:
 - 400-kHz I²C Serial Interface
 - 32 Bytes of Scratch-Pad FLASH NVM
 - Battery Low Digital Output Warning
 - Configurable SOC Interrupts
 - External Thermistor, Internal Sensor, or Host-reported Temperature Options
- Tiny 15-pin, 2610 × 1956 μm, 0.5-mm pitch NanoFree™ (DSBGA) Package

2 Applications

- Smartphones, Feature Phones, and Tablets
- Digital Still and Video Cameras
- Handheld Terminals
- MP3 or Multimedia Players

3 Description

The Texas Instruments bq27520-G4 system-side Li-Ion battery fuel gauge is a microcontroller peripheral that provides fuel gauging for single-cell Li-Ion battery packs. The device requires little system microcontroller firmware development. The fuel gauge resides on the main board of the system and manages an embedded battery (non-removable) or a removable battery pack.

The fuel gauge uses the patented Impedance Track™ algorithm for fuel gauging, and provides information such as remaining battery capacity (mAh), state-of-charge (%), run-time to empty (minimum), battery voltage (mV), temperature (°C), and state of health (%).

Battery fuel gauging requires only PACK+ (P+), PACK– (P–), and optional Thermistor (T) connections to a removable battery pack or embedded battery circuit. The device uses a 15-ball NanoFree™ (DSBGA) package in the nominal dimensions of 2610 × 1956 μm with 0.5-mm lead pitch. It is ideal for space-constrained applications.

Device Information⁽¹⁾

| PART NUMBER | PACKAGE | BODY SIZE (NOM) |
|-------------|------------|---------------------|
| bq27520-G4 | DSBGA (15) | 2.610 mm x 1.956 mm |

(1) For all available packages, see the orderable addendum at the end of the datasheet.

Typical Application Diagram

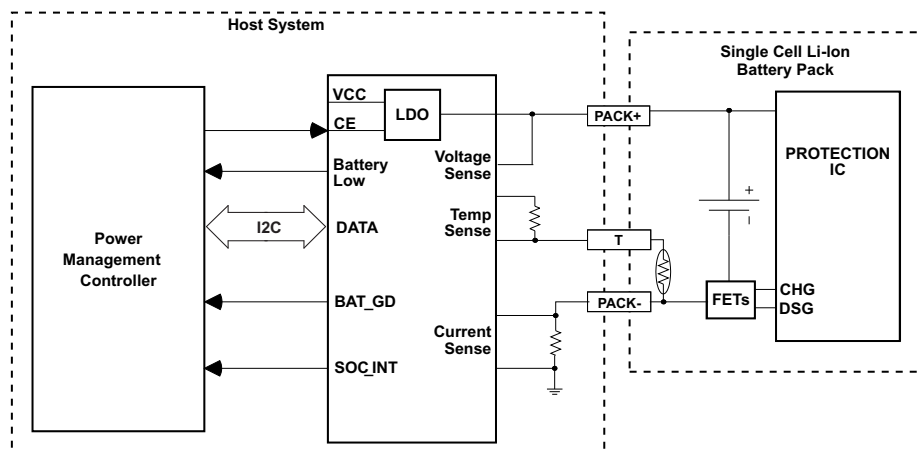

Table of Contents

| | | | |
|---|----------|--|-----------|
| 1 Features | 1 | 7.14 Typical Characteristics | 9 |
| 2 Applications | 1 | 8 Detailed Description | 10 |
| 3 Description | 1 | 8.1 Overview | 10 |
| 4 Revision History | 2 | 8.2 Functional Block Diagram | 11 |
| 5 Device Comparison Table | 3 | 8.3 Feature Description | 12 |
| 6 Pin Configuration and Functions | 4 | 8.4 Device Functional Modes | 12 |
| 7 Specifications | 5 | 8.5 Programming | 17 |
| 7.1 Absolute Maximum Ratings | 5 | 9 Application and Implementation | 21 |
| 7.2 ESD Ratings | 5 | 9.1 Application Information | 21 |
| 7.3 Recommended Operating Conditions | 5 | 9.2 Typical Application | 22 |
| 7.4 Thermal Information | 5 | 10 Power Supply Recommendations | 26 |
| 7.5 Electrical Characteristics: Supply Current | 6 | 10.1 Power Supply Decoupling | 26 |
| 7.6 Digital Input and Output DC Characteristics | 6 | 11 Layout | 26 |
| 7.7 Power-on Reset | 6 | 11.1 Layout Guidelines | 26 |
| 7.8 2.5-V LDO Regulator | 6 | 11.2 Layout Example | 27 |
| 7.9 Internal Clock Oscillators | 6 | 12 Device and Documentation Support | 28 |
| 7.10 ADC (Temperature and Cell Measurement) Characteristics | 7 | 12.1 Documentation Support | 28 |
| 7.11 Integrating ADC (Coulomb Counter) Characteristics | 7 | 12.2 Community Resources | 28 |
| 7.12 Data Flash Memory Characteristics | 7 | 12.3 Trademarks | 28 |
| 7.13 I ² C-Compatible Interface Communication Timing Requirements | 8 | 12.4 Electrostatic Discharge Caution | 28 |
| | | 12.5 Glossary | 28 |
| | | 13 Mechanical, Packaging, and Orderable Information | 28 |

4 Revision History

NOTE: Page numbers for previous revisions may differ from page numbers in the current version.

| Changes from Revision A (August 2013) to Revision B | Page |
|---|-------------|
| • Changed 32 Ahr to 14500-mAh | 1 |
| • Deleted minimum and maximum values for Power-on reset hysteresis | 6 |
| • Added <i>Device Information</i> table, <i>ESD Ratings</i> table, <i>Feature Description</i> section, <i>Device Functional Modes</i> , <i>Programming</i> section, <i>Application and Implementation</i> section, <i>Power Supply Recommendations</i> section, <i>Device</i> <i>and Documentation Support</i> section, and <i>Mechanical, Packaging, and Orderable Information</i> | 12 |
| • Changed Figure 6 | 14 |
| • Added Figure 7 | 15 |

| Changes from Original (November 2012) to Revision A | Page |
|--|-------------|
| • Aligned package description throughout datasheet | 1 |
| • Removed Ordering information table | 4 |

5 Device Comparison Table

| PRODUCTION PART NO. ⁽¹⁾ | PACKAGE ⁽²⁾ | T _A | COMMUNICATION FORMAT | TAPE AND REEL QUANTITY |
|------------------------------------|------------------------|----------------|---------------------------------|------------------------|
| bq27520YZFR-G4 | DSBGA-15 | –40°C to 85°C | I ² C ⁽¹⁾ | 3000 |
| bq27520YZFT-G4 | | | | 250 |

(1) bq27520-G4 is shipped in I²C mode

(2) For the most current package and ordering information, see the Package Option Addendum at the end of this document; or, see the TI website at www.ti.com.

6 Pin Configuration and Functions

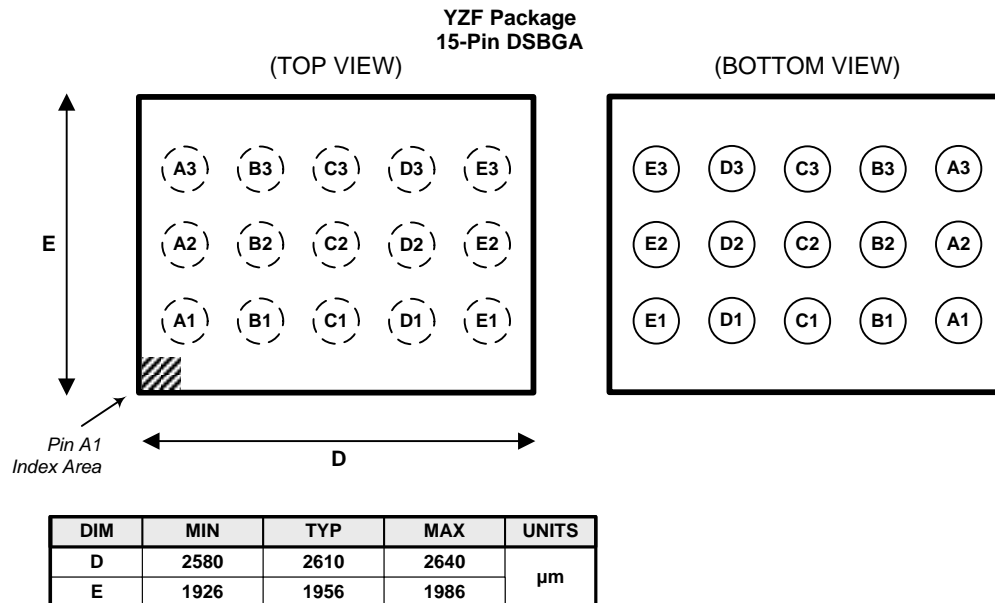

Pin Functions

| PIN | | TYPE ⁽¹⁾ | DESCRIPTION |
|----------|--------|---------------------|---|
| NAME | NUMBER | | |
| BAT | E2 | I | Cell-voltage measurement input. ADC input. Recommend 4.8 V maximum for conversion accuracy. |
| BAT_GD | B2 | O | Battery Good push-pull indicator output. Active low and output disabled by default. Polarity is configured via Op Config [BATG_POL] and the output is enabled via OpConfig C [BATGSPUEN] . |
| BAT_LOW | C3 | O | Battery Low push-pull output indicator. Active high and output enabled by default. Polarity is configured via Op Config [BATL_POL] and the output is enabled via OpConfig C [BATLSPUEN] . |
| BI/TOUT | E3 | IO | Battery-insertion detection input. Power pin for pack thermistor network. Thermistor-multiplexer control pin. Use with pullup resistor >1 MΩ (1.8 MΩ, typical). |
| CE | D2 | I | Chip Enable. Internal LDO is disconnected from REGIN when driven low. Note: CE has an internal ESD protection diode connected to REGIN. Recommend maintaining $V_{CE} \leq V_{REGIN}$ under all conditions. |
| REGIN | E1 | P | Regulator input. Decouple with 0.1-μF ceramic capacitor to V_{SS} . |
| SCL | A3 | I | Slave I ² C serial communications clock input line for communication with system (Master). Open-drain IO. Use with 10-kΩ pullup resistor (typical). |
| SDA | B3 | IO | Slave I ² C serial communications data line for communication with system (Master). Open-drain IO. Use with 10-kΩ pullup resistor (typical). |
| SOC_INT | A2 | O | SOC state interrupts output. Generates a pulse under the conditions specified in the <i>bq27520-G4 Technical Reference Manual</i> , SLUUA35 . Open drain output. |
| SRN | B1 | IA | Analog input pin connected to the internal coulomb counter with a Kelvin connection where SRN is nearest the V_{SS} connection. Connect to 5-mΩ to 20-mΩ sense resistor. |
| SRP | A1 | IA | Analog input pin connected to the internal coulomb counter with a Kelvin connection where SRP is nearest the PACK- connection. Connect to 5-mΩ to 20-mΩ sense resistor. |
| TS | D3 | IA | Pack thermistor voltage sense (use 103AT-type thermistor). ADC input. |
| V_{CC} | D1 | P | Regulator output and bq27520-G4 processor power. Decouple with 1-μF ceramic capacitor to V_{SS} . |
| V_{SS} | C1, C2 | P | Device ground |

(1) IO = Digital input-output, IA = Analog input, P = Power connection

7 Specifications

7.1 Absolute Maximum Ratings⁽¹⁾

over operating free-air temperature range (unless otherwise noted)

| | | MIN | MAX | UNIT |
|--------------------|--|------|--------------------------|------|
| V _{REGIN} | Regulator input | -0.3 | 5.5 | V |
| | | -0.3 | 6.0 ⁽²⁾ | V |
| V _{CE} | CE input pin | -0.3 | V _{REGIN} + 0.3 | V |
| V _{CC} | Supply voltage | -0.3 | 2.75 | V |
| V _{IOD} | Open-drain I/O pins (SDA, SCL, SOC_INT) | -0.3 | 5.5 | V |
| V _{BAT} | BAT input pin | -0.3 | 5.5 | V |
| | | -0.3 | 6.0 ⁽²⁾ | V |
| V _I | Input voltage to all other pins (BI/TOUT, TS, SRP, SRN, BAT_LOW, BAT_GD) | -0.3 | V _{CC} + 0.3 | V |
| T _A | Operating free-air temperature | -40 | 85 | °C |
| T _{stg} | Storage temperature | -65 | 150 | °C |

- (1) Stresses beyond those listed under *Absolute Maximum Ratings* may cause permanent damage to the device. These are stress ratings only, which do not imply functional operation of the device at these or any other conditions beyond those indicated under *Recommended Operating Conditions*. Exposure to absolute-maximum-rated conditions for extended periods may affect device reliability.
- (2) Condition not to exceed 100 hours at 25°C lifetime.

7.2 ESD Ratings

| | | | VALUE | UNIT | |
|------------------|-------------------------|---------------------------------------|--------------------|------|---|
| V _{ESD} | Electrostatic discharge | Human-body model (HBM) ⁽¹⁾ | All pins except E2 | 2000 | V |
| | | | Pin E2 | 1500 | |

- (1) JEDEC document JEP155 states that 500-V HBM allows safe manufacturing with a standard ESD control process.

7.3 Recommended Operating Conditions

T_A = -40°C to 85°C, V_{REGIN} = V_{BAT} = 3.6 V (unless otherwise noted)

| | | MIN | NOM | MAX | UNIT |
|--------------------|--|--|------|-----|------|
| V _{REGIN} | Supply voltage | No operating restrictions | 2.8 | 4.5 | V |
| | | No flash writes | 2.45 | 2.8 | |
| C _{REGIN} | External input capacitor for internal LDO between REGIN and V _{SS} | Nominal capacitor values specified. Recommend a 5% ceramic X5R-type capacitor located close to the device. | | 0.1 | μF |
| C _{LDO25} | External output capacitor for internal LDO between V _{CC} and V _{SS} | 0.47 | 1 | | μF |
| t _{PUCD} | Power-up communication delay | | | 250 | ms |

7.4 Thermal Information

over operating free-air temperature (unless otherwise noted)

| THERMAL METRIC ⁽¹⁾ | | bq27520-G4 | UNIT |
|-------------------------------|--|-------------|------|
| | | YZF (DSBGA) | |
| | | 15 PINS | |
| R _{θJA} | Junction-to-ambient thermal resistance | 70 | °C/W |
| R _{θJC(top)} | Junction-to-case (top) thermal resistance | 17 | °C/W |
| R _{θJB} | Junction-to-board thermal resistance | 20 | °C/W |
| ψ _{JT} | Junction-to-top characterization parameter | 1 | °C/W |
| ψ _{JB} | Junction-to-board characterization parameter | 18 | °C/W |
| R _{θJC(bot)} | Junction-to-case (bottom) thermal resistance | NA | °C/W |

- (1) For more information about traditional and new thermal metrics, see the *Semiconductor and IC Package Thermal Metrics* application report, [SPRA953](#).

7.5 Electrical Characteristics: Supply Current

 $T_A = 25^\circ\text{C}$ and $V_{\text{REGIN}} = V_{\text{BAT}} = 3.6\text{ V}$ (unless otherwise noted)

| PARAMETER | | TEST CONDITIONS | MIN | TYP | MAX | UNIT |
|----------------------------------|----------------------------------|--|-----|-----|-----|---------------|
| I_{CC} ⁽¹⁾ | Normal operating mode current | Fuel gauge in NORMAL mode $I_{\text{LOAD}} > \textit{Sleep current}$ | | 118 | | μA |
| $I_{\text{SLP+}}$ ⁽¹⁾ | Snooze operating mode current | Fuel gauge in SNOOZE mode $I_{\text{LOAD}} < \textit{Sleep current}$ | | 62 | | μA |
| I_{SLP} ⁽¹⁾ | Low-power storage mode current | Fuel gauge in SLEEP mode $I_{\text{LOAD}} < \textit{Sleep current}$ | | 23 | | μA |
| I_{HIB} ⁽¹⁾ | Hibernate operating mode current | Fuel gauge in HIBERNATE mode $I_{\text{LOAD}} < \textit{Hibernate current}$ | | 8 | | μA |

(1) Specified by design. Not production tested.

7.6 Digital Input and Output DC Characteristics

 $T_A = -40^\circ\text{C}$ to 85°C , typical values at $T_A = 25^\circ\text{C}$ and $V_{\text{REGIN}} = 3.6\text{ V}$ (unless otherwise noted)

| PARAMETER | | TEST CONDITIONS | MIN | TYP | MAX | UNIT |
|---------------------------------|--|---|-----------------------|-----------------------|-----|---------------|
| V_{OL} | Output voltage, low (SCL, SDA, SOC_INT, BAT_LOW, BAT_GD) | $I_{\text{OL}} = 3\text{ mA}$ | | | 0.4 | V |
| $V_{\text{OH(PP)}}$ | Output voltage, high (BAT_LOW, BAT_GD) | $I_{\text{OH}} = -1\text{ mA}$ | $V_{\text{CC}} - 0.5$ | | | V |
| $V_{\text{OH(OD)}}$ | Output voltage, high (SDA, SCL, SOC_INT) | External pullup resistor connected to V_{CC} | $V_{\text{CC}} - 0.5$ | | | |
| V_{IL} | Input voltage, low (SDA, SCL) | | -0.3 | | 0.6 | V |
| | Input voltage, low (BI/TOUT) | BAT INSERT CHECK mode active | -0.3 | | 0.6 | |
| V_{IH} | Input voltage, high (SDA, SCL) | | 1.2 | | | V |
| | Input voltage, high (BI/TOUT) | BAT INSERT CHECK mode active | 1.2 | $V_{\text{CC}} + 0.3$ | | |
| $V_{\text{IL(CE)}}$ | Input voltage, low (CE) | $V_{\text{REGIN}} = 2.8$ to 4.5 V | | | 0.8 | V |
| $V_{\text{IH(CE)}}$ | Input voltage, high (CE) | | | 2.65 | | |
| I_{IKG} ⁽¹⁾ | Input leakage current (IO pins) | | | | 0.3 | μA |

(1) Specified by design. Not production tested.

7.7 Power-on Reset

 $T_A = -40^\circ\text{C}$ to 85°C , typical values at $T_A = 25^\circ\text{C}$ and $V_{\text{REGIN}} = 3.6\text{ V}$ (unless otherwise noted)

| PARAMETER | | MIN | TYP | MAX | UNIT |
|------------------|---|------|------|------|------|
| $V_{\text{IT+}}$ | Positive-going battery voltage input at V_{CC} | 2.05 | 2.15 | 2.20 | V |
| V_{HYS} | Power-on reset hysteresis | | 115 | | mV |

7.8 2.5-V LDO Regulator

 $T_A = -40^\circ\text{C}$ to 85°C , $C_{\text{LDO25}} = 1\text{ }\mu\text{F}$, $V_{\text{REGIN}} = 3.6\text{ V}$ (unless otherwise noted)

| PARAMETER | | TEST CONDITIONS | MIN | TYP | MAX | UNIT |
|--------------------|--|--|-----|-----|-----|------|
| V_{REG25} | Regulator output voltage (V_{CC}) | $2.8\text{ V} \leq V_{\text{REGIN}} \leq 4.5\text{ V}$, $I_{\text{OUT}} \leq 16\text{ mA}$ ⁽¹⁾ | 2.3 | 2.5 | 2.6 | V |
| | | $2.45\text{ V} \leq V_{\text{REGIN}} < 2.8\text{ V}$ (low battery), $I_{\text{OUT}} \leq 3\text{ mA}$ | 2.3 | | | V |

(1) LDO output current, I_{OUT} , is the total load current. LDO regulator should be used to power internal fuel gauge only.

7.9 Internal Clock Oscillators

 $T_A = -40^\circ\text{C}$ to 85°C , $2.4\text{ V} < V_{\text{CC}} < 2.6\text{ V}$; typical values at $T_A = 25^\circ\text{C}$ and $V_{\text{CC}} = 2.5\text{ V}$ (unless otherwise noted)

| PARAMETER | | MIN | TYP | MAX | UNIT |
|-------------------|---------------------------|-----|--------|-----|------|
| f_{OSC} | High frequency oscillator | | 8.389 | | MHz |
| f_{LOSC} | Low frequency oscillator | | 32.768 | | kHz |

7.10 ADC (Temperature and Cell Measurement) Characteristics

$T_A = -40^{\circ}\text{C}$ to 85°C , $2.4\text{ V} < V_{CC} < 2.6\text{ V}$; typical values at $T_A = 25^{\circ}\text{C}$ and $V_{CC} = 2.5\text{ V}$ (unless otherwise noted)

| PARAMETER | TEST CONDITIONS | MIN | TYP | MAX | UNIT |
|-----------------------------|--|-----------------------------------|-----|-----|-------|
| V_{ADC1} | Input voltage range (TS) | $V_{\text{SS}} - 0.125$ | | 2 | V |
| V_{ADC2} | Input voltage range (BAT) | $V_{\text{SS}} - 0.125$ | | 5 | V |
| $V_{\text{IN(ADC)}}$ | Input voltage range | 0.05 | | 1 | V |
| G_{TEMP} | Internal temperature sensor voltage gain | | -2 | | mV/°C |
| $t_{\text{ADC_CONV}}$ | Conversion time | | | 125 | ms |
| | Resolution | 14 | | 15 | bits |
| $V_{\text{OS(ADC)}}$ | Input offset | | 1 | | mV |
| $Z_{\text{ADC1}}^{(1)}$ | Effective input resistance (TS) | 8 | | | MΩ |
| $Z_{\text{ADC2}}^{(1)}$ | Effective input resistance (BAT) | Device not measuring cell voltage | | 8 | MΩ |
| | | Device measuring cell voltage | | 100 | kΩ |
| $I_{\text{lkq(ADC)}}^{(1)}$ | Input leakage current | | | 0.3 | μA |

(1) Specified by design. Not tested in production.

7.11 Integrating ADC (Coulomb Counter) Characteristics

$T_A = -40^{\circ}\text{C}$ to 85°C , $2.4\text{ V} < V_{CC} < 2.6\text{ V}$; typical values at $T_A = 25^{\circ}\text{C}$ and $V_{CC} = 2.5\text{ V}$ (unless otherwise noted)

| PARAMETER | TEST CONDITIONS | MIN | TYP | MAX | UNIT |
|----------------------------|--|---|--------|--------|-------|
| V_{SR} | Input voltage range, $V_{(\text{SRP})}$ and $V_{(\text{SRN})}$ | $V_{\text{SR}} = V_{(\text{SRP})} - V_{(\text{SRN})}$ | -0.125 | 0.125 | V |
| $t_{\text{SR_CONV}}$ | Conversion time | | 1 | | s |
| | Resolution | 14 | | 15 | bits |
| $V_{\text{OS(SR)}}$ | Input offset | | 10 | | μV |
| INL | Integral nonlinearity error | | ±0.007 | ±0.034 | % FSR |
| $Z_{\text{IN(SR)}}^{(1)}$ | Effective input resistance | 2.5 | | | MΩ |
| $I_{\text{lkq(SR)}}^{(1)}$ | Input leakage current | | | 0.3 | μA |

(1) Specified by design. Not tested in production.

7.12 Data Flash Memory Characteristics

$T_A = -40^{\circ}\text{C}$ to 85°C , $2.4\text{ V} < V_{CC} < 2.6\text{ V}$; typical values at $T_A = 25^{\circ}\text{C}$ and $V_{CC} = 2.5\text{ V}$ (unless otherwise noted)

| PARAMETER | MIN | TYP | MAX | UNIT |
|-----------------------------|---|--------|-----|--------|
| $t_{\text{DR}}^{(1)}$ | Data retention | 10 | | Years |
| | Flash-programming write cycles ⁽¹⁾ | 20,000 | | Cycles |
| $t_{\text{WORDPROG}}^{(1)}$ | Word programming time | | 2 | ms |
| $I_{\text{CCPROG}}^{(1)}$ | Flash-write supply current | | 5 | mA |
| $t_{\text{DFERASE}}^{(1)}$ | Data flash master erase time | 200 | | ms |
| $t_{\text{IFERASE}}^{(1)}$ | Instruction flash master erase time | 200 | | ms |
| $t_{\text{PGERASE}}^{(1)}$ | Flash page erase time | 20 | | ms |

(1) Specified by design. Not production tested

7.13 I²C-Compatible Interface Communication Timing Requirements

$T_A = -40^{\circ}\text{C}$ to 85°C , $2.4\text{ V} < V_{CC} < 2.6\text{ V}$; typical values at $T_A = 25^{\circ}\text{C}$ and $V_{CC} = 2.5\text{ V}$ (unless otherwise noted)

| | | MIN | NOM | MAX | UNIT |
|----------------|--------------------------------------|-----|-----|-----|---------------|
| t_r | SCL or SDA rise time | | | 300 | ns |
| t_f | SCL or SDA fall time | | | 300 | ns |
| $t_{w(H)}$ | SCL pulse duration (high) | 600 | | | ns |
| $t_{w(L)}$ | SCL pulse duration (low) | 1.3 | | | μs |
| $t_{su(STA)}$ | Setup for repeated start | 600 | | | ns |
| $t_{d(STA)}$ | Start to first falling edge of SCL | 600 | | | ns |
| $t_{su(DAT)}$ | Data setup time | 100 | | | ns |
| $t_{h(DAT)}$ | Data hold time | 0 | | | ns |
| $t_{su(STOP)}$ | Setup time for stop | 600 | | | ns |
| $t_{(BUF)}$ | Bus free time between stop and start | 66 | | | μs |
| f_{SCL} | Clock frequency ⁽¹⁾ | | | 400 | kHz |

(1) If the clock frequency (f_{SCL}) is $> 100\text{ kHz}$, use 1-byte write commands for proper operation. All other transactions types are supported at 400 kHz . (See [I²C Interface](#) and [I²C Command Waiting Time](#)).

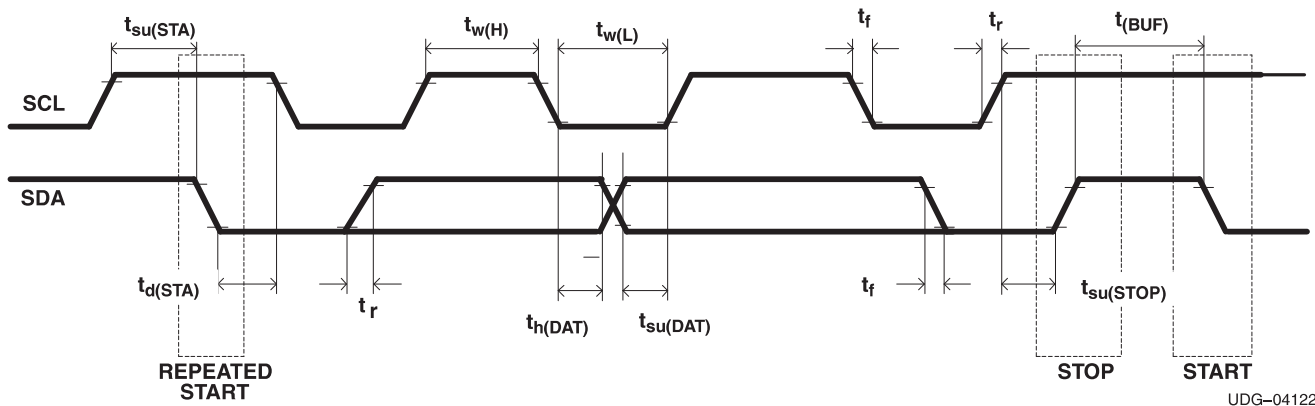

Figure 1. I²C-Compatible Interface Timing Diagrams

7.14 Typical Characteristics

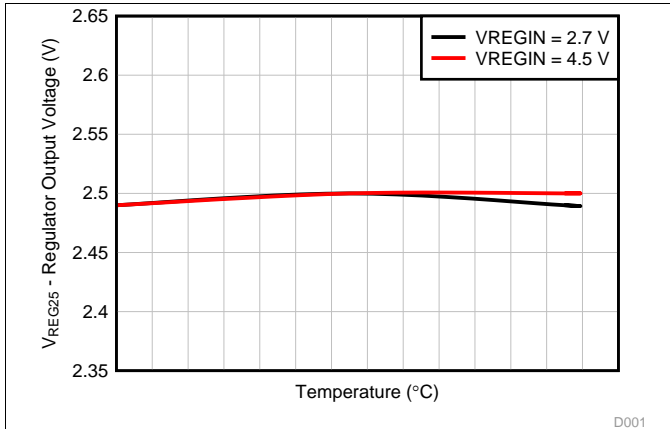

Figure 2. Regulator Output Voltage vs. Temperature

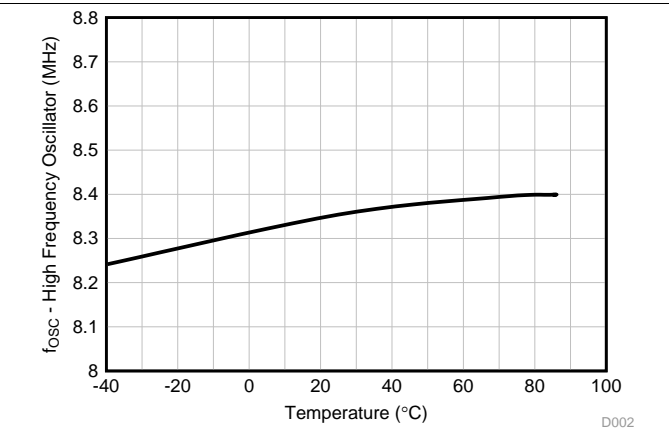

Figure 3. High-Frequency Oscillator Frequency vs. Temperature

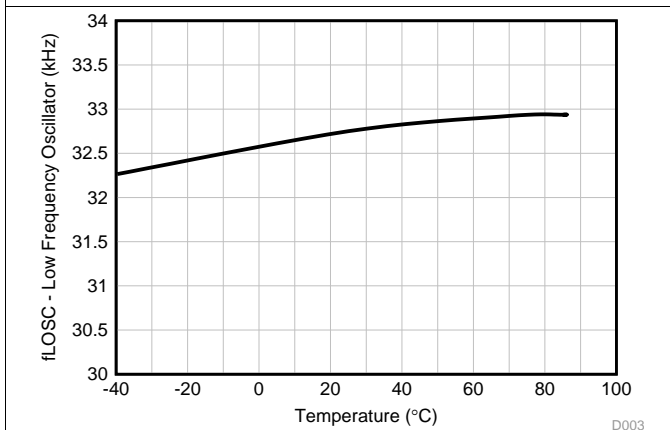

Figure 4. Low-Frequency Oscillator Frequency vs. Temperature

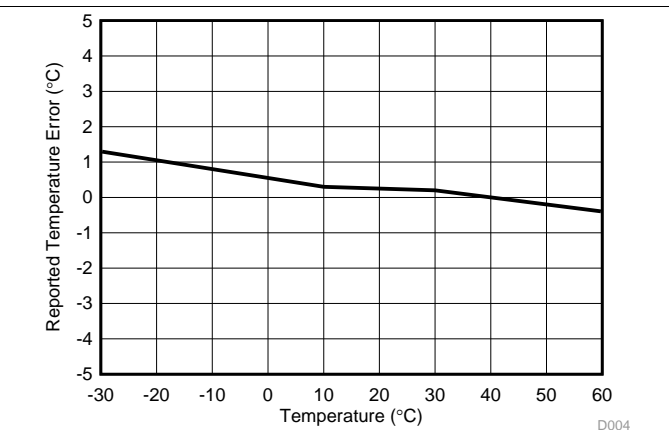

Figure 5. Reported Internal Temperature Measurement vs. Temperature

8 Detailed Description

8.1 Overview

The bq27520-G4 fuel gauge accurately predicts the battery capacity and other operational characteristics of a single Li-based rechargeable cell. It can be interrogated by a system processor to provide cell information, such as time-to-empty (TTE), state-of-charge (SOC), and SOC interrupt signal to the host.

Information is accessed through a series of commands, called *Standard Commands*. Further capabilities are provided by the additional *Extended Commands* set. Both sets of commands, indicated by the general format *Command()*, are used to read and write information contained within the device control and status registers, as well as its data flash locations. Commands are sent from system to gauge using the I²C serial communications engine, and can be executed during application development, system manufacture, or end-equipment operation.

Cell information is stored in the device in non-volatile flash memory. Many of these data flash locations are accessible during application development. They cannot generally be accessed directly during end-equipment operation. Access to these locations is achieved by either use of the companion evaluation software, through individual commands, or through a sequence of data-flash-access commands. To access a desired data flash location, the correct data flash subclass and offset must be known.

The key to the high-accuracy gas gauging prediction is Texas Instruments proprietary Impedance Track™ algorithm. This algorithm uses cell measurements, characteristics, and properties to create state-of-charge predictions that can achieve less than 1% error across a wide variety of operating conditions and over the lifetime of the battery.

The fuel gauge measures charge and discharge activity by monitoring the voltage across a small-value series sense resistor (5 mΩ to 20 mΩ, typical) located between the system V_{SS} and the battery PACK– terminal. When a cell is attached to the device, cell impedance is learned based on cell current, cell open-circuit voltage (OCV), and cell voltage under loading conditions.

The external temperature sensing is optimized with the use of a high-accuracy negative temperature coefficient (NTC) thermistor with R₂₅ = 10.0 kΩ ±1%. B_{25/85} = 3435K ± 1% (such as Semitec NTC 103AT). Alternatively, the fuel gauge can also be configured to use its internal temperature sensor or receive temperature data from the host processor. When an external thermistor is used, a 18.2-kΩ pullup resistor between the BI/TOUT and TS pins is also required. The fuel gauge uses temperature to monitor the battery-pack environment, which is used for fuel gauging and cell protection functionality.

To minimize power consumption, the device has different power modes: NORMAL, SNOOZE, SLEEP, HIBERNATE, and BAT INSERT CHECK. The fuel gauge automatically changes modes depending upon the occurrence of specific events, though a system processor can initiate some of these modes directly.

For complete operational details, see *bq27520-G4 Technical Reference Manual*, [SLUUA35](#).

NOTE

The following formatting conventions are used in this document:

Commands: *italics* with parentheses () and no breaking spaces, for example, *Control()*.

Data Flash: *italics*, **bold**, and breaking spaces, for example, ***Design Capacity***.

Register bits and flags: *italics* with brackets [], for example, *[TDA]*

Data flash bits: *italics*, **bold**, and brackets [], for example, ***[LED1]***

Modes and states: ALL CAPITALS, for example, UNSEALED mode.

8.2 Functional Block Diagram

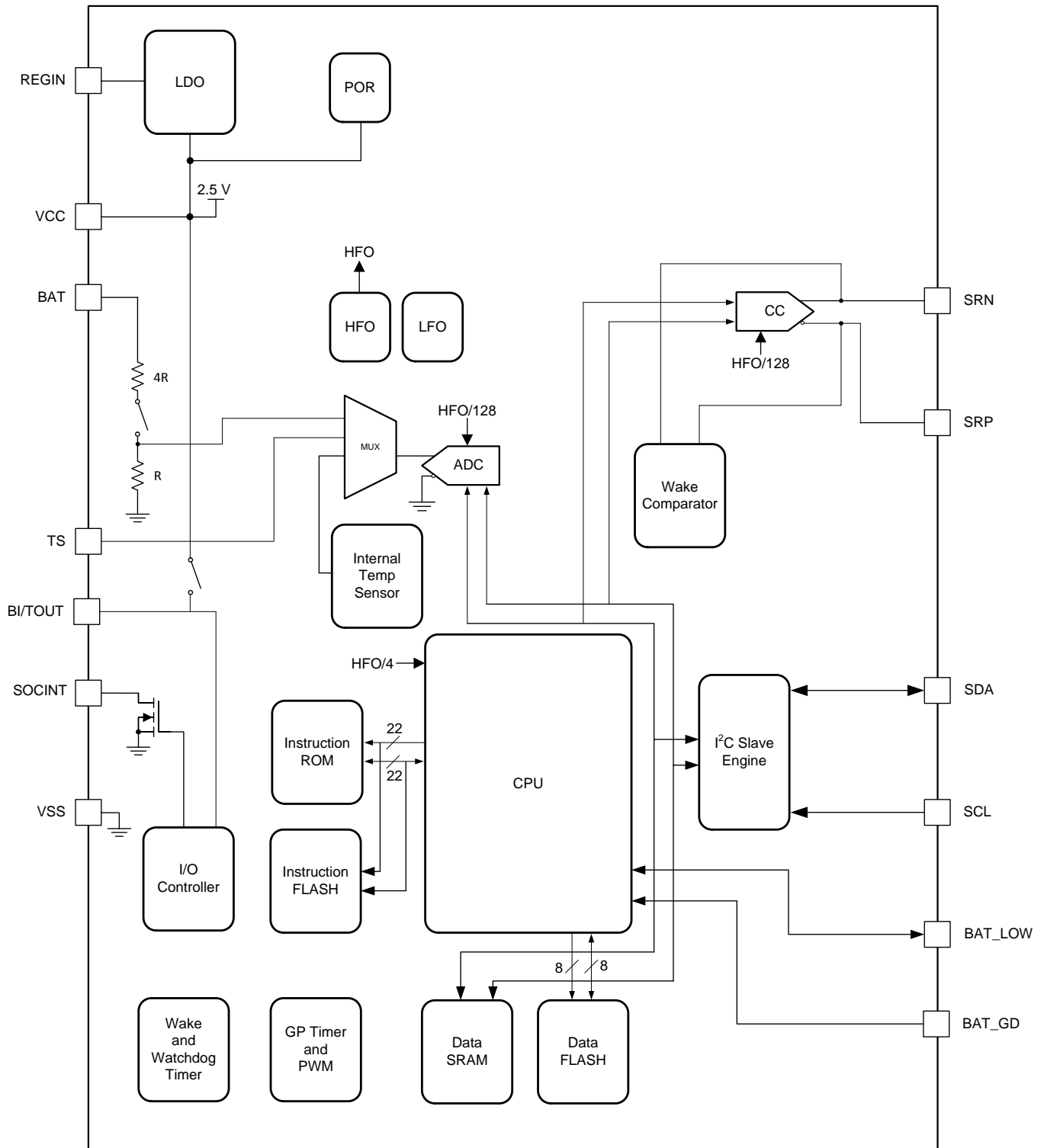

8.3 Feature Description

The bq27520-G4 measures the voltage, temperature, and current to determine battery capacity and state-of-charge (SOC) based on the patented Impedance Track™ algorithm (Refer to Application Report, *Theory and Implementation of Impedance Track Battery Fuel-Gauging Algorithm*, [SLUA450](#) for more information). The bq27520-G4 monitors charge and discharge activity by sensing the voltage across a small-value resistor (5 mΩ to 20 mΩ typical) between the SRP and SRN pins and in series with the battery. By integrating charge passing through the battery, the battery's SOC is adjusted during battery charge or discharge. Battery capacity is found by comparing states of charge before and after applying the load with the amount of charge passed. When a system load is applied, the impedance of the battery is measured by comparing the open circuit voltage (OCV) obtained from a predefined function for present SOC with the measured voltage under load. Measurements of OCV and charge integration determine chemical state-of-charge and chemical capacity (Qmax). The initial Qmax values are taken from a cell manufacturers' data sheet multiplied by the number of parallel cells. It is also used for the value in **Design Capacity**. The bq27520-G4 acquires and updates the battery-impedance profile during normal battery usage. It uses this profile, along with SOC and the Qmax value, to determine *FullChargeCapacity()* and *StateOfCharge()*, specifically for the present load and temperature. *FullChargeCapacity()* is reported as capacity available from a fully charged battery under the present load and temperature until *Voltage()* reaches the **Terminate Voltage**. *NominalAvailableCapacity()* and *FullAvailableCapacity()* are the uncompensated (no or light load) versions of *RemainingCapacity()* and *FullChargeCapacity()*, respectively. The bq27520-G4 has two *Flags()* bits and two pins to warn the host if the battery's SOC has fallen to critical levels. If *RemainingCapacity()* falls below the first capacity threshold specified by **SOC1 Set Threshold**, the *Flags()* [SOC1] bit is set and is cleared if *RemainingCapacity()* rises above the **SOC1 Clear Threshold**. If enabled via **OpConfig C [BATLSPUEN]**, the BAT_LOW pin reflects the status of the [SOC1] flag bit. If enabled by **OpConfig B [BL_INT]**, the SOC_INT will toggle upon a state change of the [SOC1] flag bit. As *Voltage()* falls below the **SysDown Set Volt Threshold**, the *Flags()* [SYSDOWN] bit is set and SOC_INT will toggle once to provide a final warning to shut down the system. As *Voltage()* rises above **SysDown Clear Voltage** the [SYSDOWN] bit is cleared and SOC_INT will toggle once to signal the status change. Additional details are found in the *bq27520-G4 Technical Reference Manual*, [SLUUA35](#).

8.4 Device Functional Modes

8.4.1 Power Modes

The fuel gauge has different power modes:

- **BAT INSERT CHECK:** The BAT INSERT CHECK mode is a powered-up, but low-power halted, state where the fuel gauge resides when no battery is inserted into the system.
- **NORMAL:** In NORMAL mode, the fuel gauge is fully powered and can execute any allowable task.
- **SLEEP:** In SLEEP mode, the fuel gauge turns off the high-frequency oscillator and operates in a reduced-power state, periodically taking measurements and performing calculations.
- **SLEEP+:** In SLEEP+ mode, both low-frequency and high-frequency oscillators are active. Although the SLEEP+ mode has higher current consumption than the SLEEP mode, it is also a reduced power mode.
- **HIBERNATE:** In HIBERNATE mode, the fuel gauge is in a low power state, but can wake up by communication or certain I/O activity.

The relationship between these modes is shown in [Figure 6](#) and [Figure 7](#).

8.4.1.1 BAT INSERT CHECK Mode

This mode is a halted-CPU state that occurs when an adapter, or other power source, is present to power the fuel gauge (and system), but no battery has been detected. When battery insertion is detected, a series of initialization activities begin, which include: OCV measurement, setting the *Flags()* [BAT_DET] bit, and selecting the appropriate battery profiles.

Some commands, issued by a system processor, can be processed while the fuel gauge is halted in this mode. The gauge wakes up to process the command, then returns to the halted state awaiting battery insertion.

8.4.1.2 NORMAL Mode

The fuel gauge is in NORMAL mode when not in any other power mode. During this mode, *AverageCurrent()*, *Voltage()*, and *Temperature()* measurements are taken, and the interface data set is updated. Decisions to change states are also made. This mode is exited by activating a different power mode.

Device Functional Modes (continued)

Because the gauge consumes the most power in NORMAL mode, the Impedance Track algorithm minimizes the time the fuel gauge remains in this mode.

8.4.1.3 SLEEP Mode

SLEEP mode is entered automatically if the feature is enabled (*Op Config [SLEEP] = 1*) and *AverageCurrent()* is below the programmable level **Sleep Current**. Once entry into SLEEP mode has been qualified, but prior to entering it, the fuel gauge performs a coulomb counter autocalibration to minimize offset.

During SLEEP mode, the fuel gauge periodically takes data measurements and updates its data set. However, a majority of its time is spent in an idle condition.

The fuel gauge exits SLEEP mode if any entry condition is broken, specifically when:

- *AverageCurrent()* rises above **Sleep Current**, or
- A current in excess of I_{WAKE} through R_{SENSE} is detected.

In the event that a battery is removed from the system while a charger is present (and powering the gauge), Impedance Track updates are not necessary. Hence, the fuel gauge enters a state that checks for battery insertion and does not continue executing the Impedance Track algorithm.

Device Functional Modes (continued)

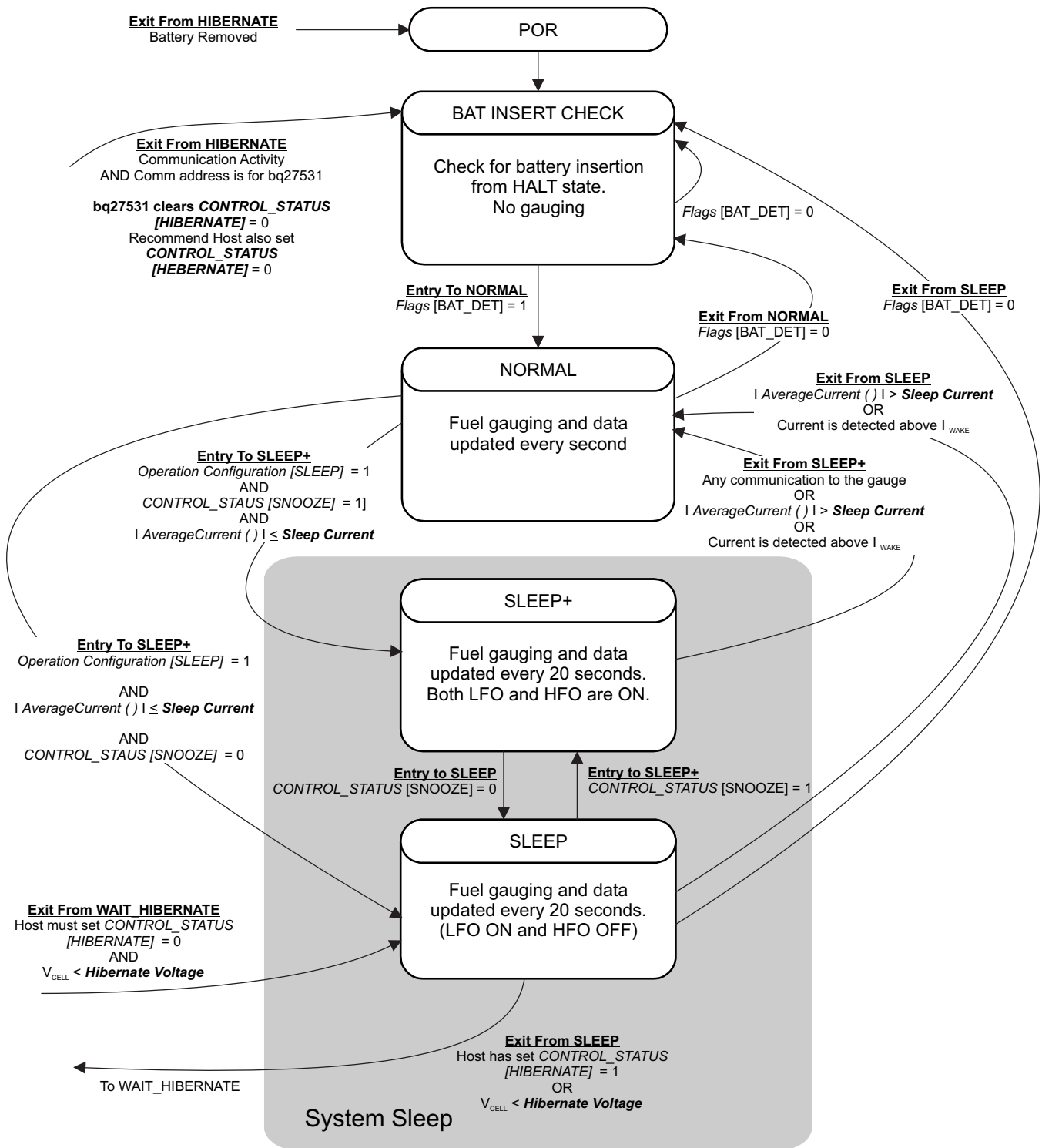

Figure 6. Power Mode Diagram—System Sleep

Device Functional Modes (continued)

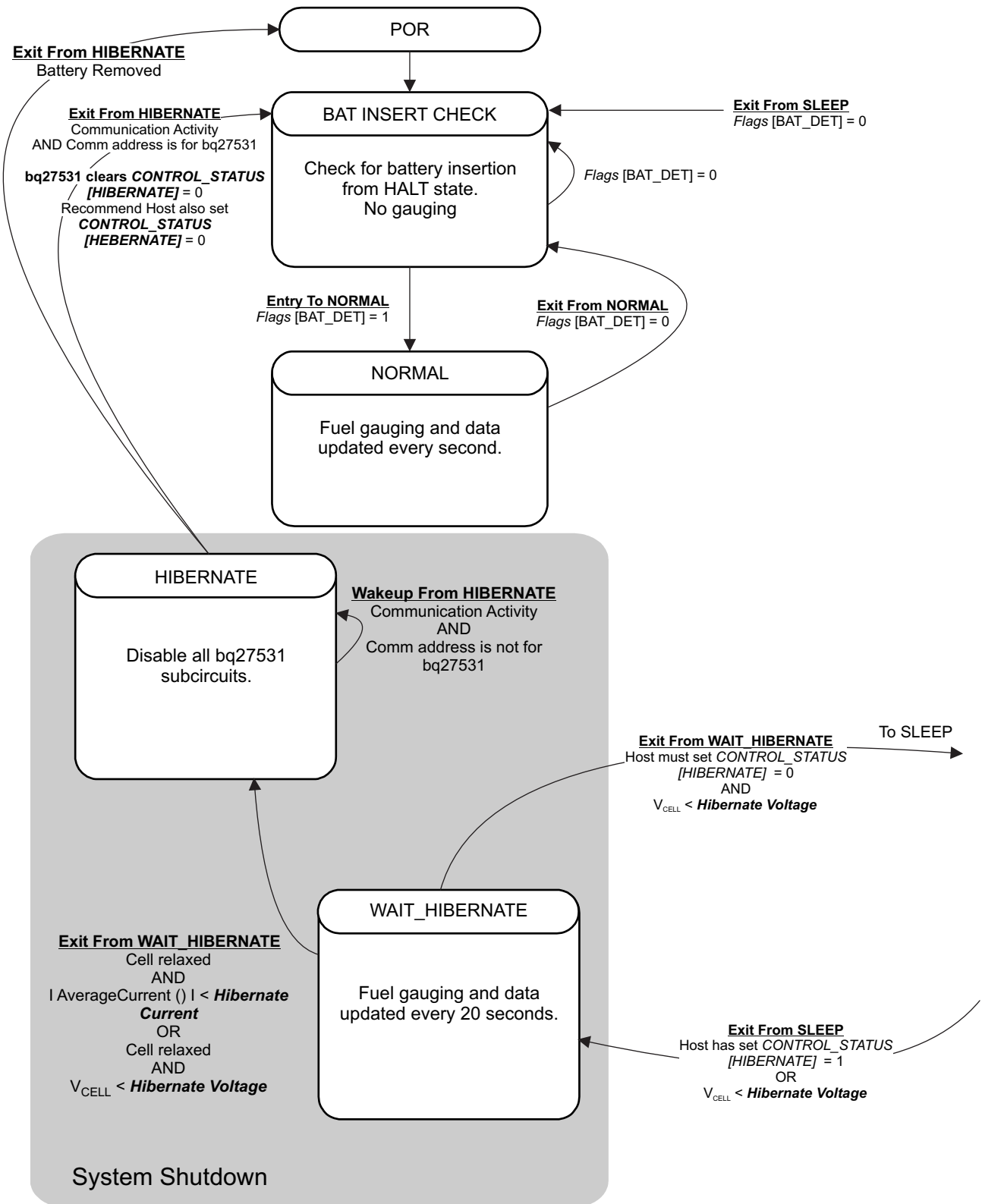

Figure 7. Power Mode Diagram—System Shutdown

Device Functional Modes (continued)

8.4.2 SLEEP+ Mode

Compared to the SLEEP mode, SLEEP+ mode has the high-frequency oscillator in operation. The communication delay could be eliminated. The SLEEP+ mode is entered automatically if the feature is enabled (*CONTROL_STATUS [SNOOZE] = 1*) and *AverageCurrent()* is below the programmable level **Sleep Current**.

During SLEEP+ mode, the fuel gauge periodically takes data measurements and updates its data set. However, a majority of its time is spent in an idle condition.

The fuel gauge exits SLEEP+ mode if any entry condition is broken, specifically when:

- Any communication activity with the gauge, or
- *AverageCurrent()* rises above **Sleep Current**, or
- A current in excess of I_{WAKE} through R_{SENSE} is detected.

8.4.3 HIBERNATE Mode

HIBERNATE mode should be used when the system equipment needs to enter a low-power state, and minimal gauge power consumption is required. This mode is ideal when system equipment is set to its own HIBERNATE, SHUTDOWN, or OFF mode.

Before the fuel gauge can enter HIBERNATE mode, the system must set the *CONTROL_STATUS [HIBERNATE]* bit. The gauge waits to enter HIBERNATE mode until it has taken a valid OCV measurement and the magnitude of the average cell current has fallen below **Hibernate Current**. The gauge can also enter HIBERNATE mode if the cell voltage falls below **Hibernate Voltage** and a valid OCV measurement has been taken. The gauge remains in HIBERNATE mode until the system issues a direct I²C command to the gauge or a POR occurs. Any I²C communication that is not directed to the gauge does not wake the gauge.

It is the responsibility of the system to wake the fuel gauge after it has gone into HIBERNATE mode. After waking, the gauge can proceed with the initialization of the battery information (OCV, profile selection, and so forth).

8.5 Programming

8.5.1 Standard Data Commands

The fuel gauge uses a series of 2-byte standard commands to enable system reading and writing of battery information. Each standard command has an associated command-code pair, as indicated in [Table 1](#). Because each command consists of two bytes of data, two consecutive I²C transmissions must be executed both to initiate the command function and to read or write the corresponding two bytes of data. Additional options for transferring data are described in [Extended Data Commands](#). Read and write permissions depend on the active access mode, SEALED or UNSEALED. For details, see *bq27520-G4 Technical Reference Manual, SLUUA35*. See [Communications](#) for I²C details.

Table 1. Standard Commands

| NAME | | COMMAND CODE | UNIT | SEALED ACCESS |
|-----------------------------------|-----------|---------------|---------|---------------|
| <i>Control()</i> | CNTL | 0x00 and 0x01 | NA | RW |
| <i>AtRate()</i> | AR | 0x02 and 0x03 | mA | RW |
| <i>AtRateTimeToEmpty()</i> | ARTTE | 0x04 and 0x05 | Minutes | R |
| <i>Temperature()</i> | TEMP | 0x06 and 0x07 | 0.1°K | RW |
| <i>Voltage()</i> | VOLT | 0x08 and 0x09 | mV | R |
| <i>Flags()</i> | FLAGS | 0x0A and 0x0B | NA | R |
| <i>NominalAvailableCapacity()</i> | NAC | 0x0C and 0x0D | mAh | R |
| <i>FullAvailableCapacity()</i> | FAC | 0x0E and 0x0F | mAh | R |
| <i>RemainingCapacity()</i> | RM | 0x10 and 0x11 | mAh | R |
| <i>FullChargeCapacity()</i> | FCC | 0x12 and 0x13 | mAh | R |
| <i>AverageCurrent()</i> | AI | 0x14 and 0x15 | mA | R |
| <i>TimeToEmpty()</i> | TTE | 0x16 and 0x17 | Minutes | R |
| <i>StandbyCurrent()</i> | SI | 0x18 and 0x19 | mA | R |
| <i>StandbyTimeToEmpty()</i> | STTE | 0x1A and 0x1B | Minutes | R |
| <i>StateOfHealth()</i> | SOH | 0x1C and 0x1D | % / num | R |
| <i>CycleCount()</i> | CC | 0x1E and 0x1F | num | R |
| <i>StateOfCharge()</i> | SOC | 0x20 and 0x21 | % | R |
| <i>InstantaneousCurrent()</i> | | 0x22 and 0x23 | mA | R |
| <i>InternalTemperature()</i> | INTTEMP | 0x28 and 0x29 | 0.1°K | R |
| <i>ResistanceScale()</i> | | 0x2A and 0x2B | | R |
| <i>OperationConfiguration()</i> | Op Config | 0x2C and 0x2D | NA | R |
| <i>DesignCapacity()</i> | | 0x2E and 0x2F | mAh | R |
| <i>UnfilteredRM()</i> | UFRM | 0x6C and 0x6D | mAh | R |
| <i>FilteredRM()</i> | FRM | 0x6E and 0x6F | mAh | R |
| <i>UnfilteredFCC()</i> | UFFCC | 0x70 and 0x71 | mAh | R |
| <i>FilteredFCC()</i> | FFCC | 0x72 and 0x73 | mAh | R |
| <i>TrueSOC()</i> | UFSOC | 0x74 and 0x75 | % | R |

8.5.2 Extended Data Commands

Extended commands offer additional functionality beyond the standard set of commands. They are used in the same manner; however, unlike standard commands, extended commands are not limited to 2-byte words. The number of command bytes for a given extended command range in size from single to multiple bytes is specified in [Table 2](#). See *bq27520-G4 Technical Reference Manual, SLUUA35* for details on accessing the data flash.

Table 2. Extended Data Commands

| NAME | COMMAND CODE | UNIT | SEALED ACCESS ^{(1) (2)} | UNSEALED ACCESS ^{(1) (2)} |
|--|--------------|------|----------------------------------|------------------------------------|
| Reserved | 0x34 to 0x3D | NA | R | R |
| <i>DataFlashClass()</i> ⁽²⁾ | 0x3E | NA | NA | RW |
| <i>DataFlashBlock()</i> ⁽²⁾ | 0x3F | NA | RW | RW |
| <i>BlockData()</i> | 0x40 to 0x5F | NA | R | RW |
| <i>BlockDataChecksum()</i> | 0x60 | NA | RW | RW |
| <i>BlockDataControl()</i> | 0x61 | NA | NA | RW |
| <i>ApplicationStatus()</i> | 0x6A | NA | R | R |
| Reserved | 0x6B to 0x7F | NA | R | R |

(1) SEALED and UNSEALED states are entered via commands to *Control()* 0x00 and 0x01.

(2) In sealed mode, data flash cannot be accessed through commands 0x3E and 0x3F.

8.5.3 Communications

8.5.3.1 I²C Interface

The bq27520-G4 fuel gauge supports the standard I²C read, incremental read, quick read, one byte write, and incremental write functions. The 7-bit device address (ADDR) is the most significant 7 bits of the hex address and is fixed as 1010101. The first 8-bits of the I²C protocol is, therefore, 0xAA or 0xAB for write or read, respectively.

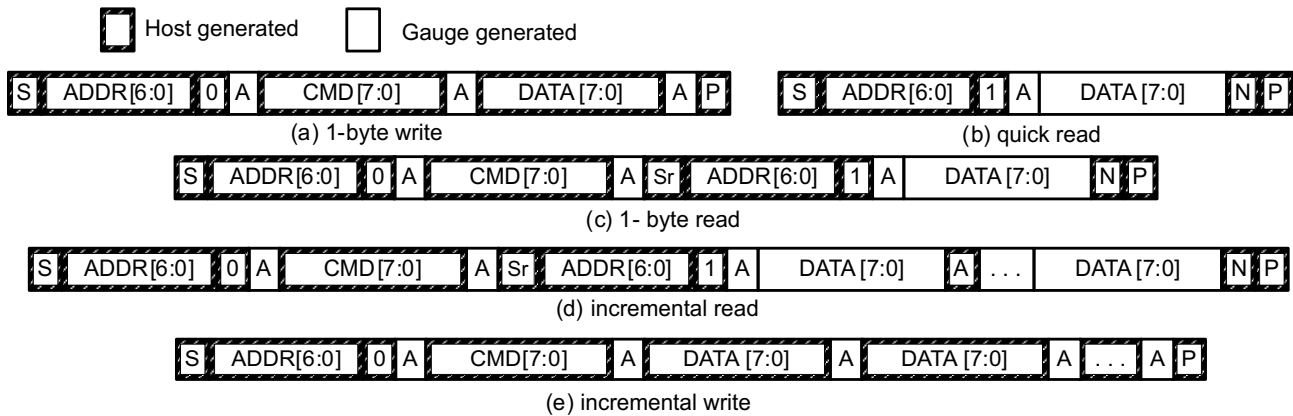

(S = Start, Sr = Repeated Start, A = Acknowledge, N = No Acknowledge, and P = Stop).

Figure 8. I²C Read, Incremental Read, Quick Read, One Byte Write, and Incremental Write Functions

The “quick read” returns data at the address indicated by the address pointer. The address pointer, a register internal to the I²C communication engine, increments whenever data is acknowledged by the fuel gauge or the I²C master. “Quick writes” function in the same manner and are a convenient means of sending multiple bytes to consecutive command locations (such as two-byte commands that require two bytes of data).

The following command sequences are not supported:

Attempt to write a read-only address (NACK after data sent by master):

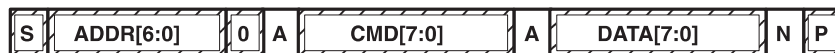

Figure 9. Invalid Write

Attempt to read an address above 0x6B (NACK command):



Figure 10. Invalid Read

8.5.3.2 I²C Time Out

The I²C engine releases both SDA and SCL if the I²C bus is held low for 2 seconds. If the fuel gauge was holding the lines, releasing them frees them for the master to drive the lines. If an external condition is holding either of the lines low, the I²C engine enters the low-power sleep mode.

8.5.3.3 I²C Command Waiting Time

To ensure proper operation at 400 kHz, a $t_{(BUF)} \geq 66 \mu s$ bus free waiting time must be inserted between all packets addressed to the fuel gauge. In addition, if the SCL clock frequency (f_{SCL}) is > 100 kHz, use individual 1-byte write commands for proper data flow control. The following diagram shows the standard waiting time required between issuing the control subcommand the reading the status result. An *OCV_CMD* subcommand requires 1.2 seconds prior to reading the result. For read-write standard command, a minimum of 2 seconds is required to get the result updated. For read-only standard commands, there is no waiting time required, but the host should not issue all standard commands more than two times per second. Otherwise, the fuel gauge could result in a reset issue due to the expiration of the watchdog timer.

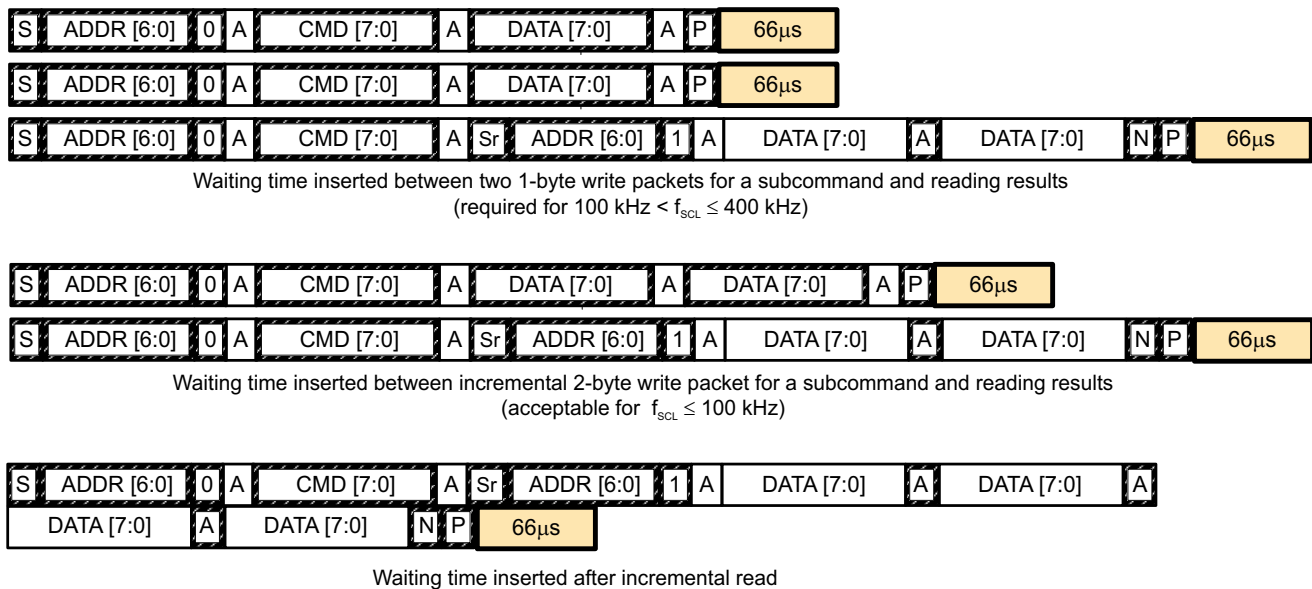

Figure 11. Standard I²C Command Waiting Time Required

8.5.3.4 I²C Clock Stretching

A clock stretch can occur during all modes of fuel gauge operation. In SLEEP and HIBERNATE modes, a short clock stretch occurs on all I²C traffic as the device must wake-up to process the packet. In the other modes (BAT INSERT CHECK, NORMAL, SNOOZE) clock stretching only occurs for packets addressed for the fuel gauge. The majority of clock stretch periods are small as the I²C interface performs normal data flow control. However, less frequent yet more significant clock stretch periods may occur as blocks of Data Flash are updated. The following table summarizes the approximate clock stretch duration for various fuel gauge operating conditions.

Table 3. Approximate Clock Stretch Duration

| GAUGING MODE | OPERATING CONDITION or COMMENT | APPROXIMATE DURATION |
|---|---|-------------------------|
| SLEEP HIBERNATE | Clock stretch occurs at the beginning of all traffic as the device wakes up. | 5 ms |
| BAT INSERT CHECK, NORMAL, SNOOZE | Clock stretch occurs within the packet for flow control (after a start bit, ACK or first data bit). | 100 μ s |
| | Normal Ra table Data Flash updates. | 24 ms |
| | Data Flash block writes. | 72 ms |
| | Restored Data Flash block write after loss of power. | 116 ms |
| | End of discharge Ra table Data Flash update. | 144 ms |

9 Application and Implementation

NOTE

Information in the following applications sections is not part of the TI component specification, and TI does not warrant its accuracy or completeness. TI's customers are responsible for determining suitability of components for their purposes. Customers should validate and test their design implementation to confirm system functionality.

9.1 Application Information

The bq27520-G4 system-side Li-Ion battery fuel gauge is a microcontroller peripheral that provides fuel gauging for single-cell Li-Ion battery packs. The device requires little system microcontroller firmware development. The fuel resides on the main board of the system and manages an embedded battery (non-removable) or a up to 14500-mAhr Capacity removable battery pack. To allow for optimal performance in the end application, special considerations must be taken to ensure minimization of measurement error through proper printed circuit board (PCB) board layout. Such requirements are detailed in [Design Requirements](#).

9.2.1 Design Requirements

Several key parameters must be updated to align with a given application's battery characteristics. For highest accuracy gauging, it is important to follow-up this initial configuration with a learning cycle to optimize resistance and maximum chemical capacity (Qmax) values prior to sealing and shipping systems to the field. Successful and accurate configuration of the fuel gauge for a target application can be used as the basis for creating a "golden" gas gauge (.fs) file that can be written to all gauges, assuming identical pack design and Li-ion cell origin (chemistry, lot, and so on). Calibration data is included as part of this golden GG file to cut down on system production time. If going this route, it is recommended to average the voltage and current measurement calibration data from a large sample size and use these in the golden file. [Table 4, Key Data Flash Parameters for Configuration](#), shows the items that should be configured to achieve reliable protection and accurate gauging with minimal initial configuration.

Table 4. Key Data Flash Parameters for Configuration

| NAME | DEFAULT | UNIT | RECOMMENDED SETTING |
|-----------------------|---------|------|---|
| Design Capacity | 1000 | mAh | Set based on the nominal pack capacity as interpreted from cell manufacturer's datasheet. If multiple parallel cells are used, should be set to N × Cell Capacity. |
| Design Energy Scale | 1 | - | Set to 10 to convert all power values to cWh or to 1 for mWh. Design Energy is divided by this value. |
| Reserve Capacity-mAh | 0 | mAh | Set to desired runtime remaining (in seconds / 3600) × typical applied load between reporting 0% SOC and reaching Terminate Voltage , if needed. |
| Chem ID | 0100 | hex | Should be configured using TI-supplied Battery Management Studio software. Default open-circuit voltage and resistance tables are also updated in conjunction with this step. Do not attempt to manually update reported Device Chemistry as this does not change all chemistry information! Always update chemistry using the appropriate software tool (that is, bqStudio). |
| Load Mode | 1 | - | Set to applicable load model, 0 for constant current or 1 for constant power. |
| Load Select | 1 | - | Set to load profile which most closely matches typical system load. |
| Qmax Cell 0 | 1000 | mAh | Set to initial configured value for Design Capacity. The gauge will update this parameter automatically after the optimization cycle and for every regular Qmax update thereafter. |
| Cell0 V at Chg Term | 4200 | mV | Set to nominal cell voltage for a fully charged cell. The gauge will update this parameter automatically each time full charge termination is detected. |
| Terminate Voltage | 3200 | mV | Set to empty point reference of battery based on system needs. Typical is between 3000 and 3200 mV. |
| Ra Max Delta | 44 | mΩ | Set to 15% of Cell0 R _{a4} resistance after an optimization cycle is completed. |
| Charging Voltage | 4200 | mV | Set based on nominal charge voltage for the battery in normal conditions (25°C, etc). Used as the reference point for offsetting by Taper Voltage for full charge termination detection. |
| Taper Current | 100 | mA | Set to the nominal taper current of the charger + taper current tolerance to ensure that the gauge will reliably detect charge termination. |
| Taper Voltage | 100 | mV | Sets the voltage window for qualifying full charge termination. Can be set tighter to avoid or wider to ensure possibility of reporting 100% SOC in outer JEITA temperature ranges that use derated charging voltage. |
| Dsg Current Threshold | 60 | mA | Sets threshold for gauge detecting battery discharge. Should be set lower than minimal system load expected in the application and higher than Quit Current . |
| Chg Current Threshold | 75 | mA | Sets the threshold for detecting battery charge. Can be set higher or lower depending on typical trickle charge current used. Also should be set higher than Quit Current . |
| Quit Current | 40 | mA | Sets threshold for gauge detecting battery relaxation. Can be set higher or lower depending on typical standby current and exhibited in the end system. |
| Avg I Last Run | -299 | mA | Current profile used in capacity simulations at onset of discharge or at all times if Load Select = 0. Should be set to nominal system load. Is automatically updated by the gauge every cycle. |
| Avg P Last Run | -1131 | mW | Power profile used in capacity simulations at onset of discharge or at all times if Load Select = 0. Should be set to nominal system power. Is automatically updated by the gauge every cycle. |
| Sleep Current | 15 | mA | Sets the threshold at which the fuel gauge enters SLEEP mode. Take care in setting above typical standby currents else entry to SLEEP may be unintentionally blocked. |

Table 4. Key Data Flash Parameters for Configuration (continued)

| NAME | DEFAULT | UNIT | RECOMMENDED SETTING |
|---------------|---------|--------|--|
| CC Gain | 10 | mΩ | Calibrate this parameter using TI-supplied bqStudio software and calibration procedure in the TRM. Determines conversion of coulomb counter measured sense resistor voltage to current. |
| CC Delta | 10 | mΩ | Calibrate this parameter using TI-supplied bqStudio software and calibration procedure in the TRM. Determines conversion of coulomb counter measured sense resistor voltage to passed charge. |
| CC Offset | -1418 | Counts | Calibrate this parameter using TI-supplied bqStudio software and calibration procedure in the TRM. Determines native offset of coulomb counter hardware that should be removed from conversions. |
| Board Offset | 0 | Counts | Calibrate this parameter using TI-supplied bqStudio software and calibration procedure in the TRM. Determines native offset of the printed circuit board parasitics that should be removed from conversions. |
| Pack V Offset | 0 | mV | Calibrate this parameter using TI-supplied bqStudio software and calibration procedure in the TRM. Determines voltage offset between cell tab and ADC input node to incorporate back into or remove from measurement, depending on polarity. |

9.2.2 Detailed Design Procedure

9.2.2.1 BAT Voltage Sense Input

A ceramic capacitor at the input to the BAT pin is used to bypass AC voltage ripple to ground, greatly reducing its influence on battery voltage measurements. It proves most effective in applications with load profiles that exhibit high-frequency current pulses (that is, cell phones) but is recommended for use in all applications to reduce noise on this sensitive high-impedance measurement node.

9.2.2.2 SRP and SRN Current Sense Inputs

The filter network at the input to the coulomb counter is intended to improve differential mode rejection of voltage measured across the sense resistor. These components should be placed as close as possible to the coulomb counter inputs and the routing of the differential traces length-matched to best minimize impedance mismatch-induced measurement errors.

9.2.2.3 Sense Resistor Selection

Any variation encountered in the resistance present between the SRP and SRN pins of the fuel gauge will affect the resulting differential voltage, and derived current, it senses. As such, it is recommended to select a sense resistor with minimal tolerance and temperature coefficient of resistance (TCR) characteristics. The standard recommendation based on best compromise between performance and price is a 1% tolerance, 100 ppm drift sense resistor with a 1-W power rating.

9.2.2.4 TS Temperature Sense Input

Similar to the BAT pin, a ceramic decoupling capacitor for the TS pin is used to bypass AC voltage ripple away from the high-impedance ADC input, minimizing measurement error. Another helpful advantage is that the capacitor provides additional ESD protection since the TS input to system may be accessible in systems that use removable battery packs. It should be placed as close as possible to the respective input pin for optimal filtering performance.

9.2.2.5 Thermistor Selection

The fuel gauge temperature sensing circuitry is designed to work with a negative temperature coefficient-type (NTC) thermistor with a characteristic 10-kΩ resistance at room temperature (25°C). The default curve-fitting coefficients configured in the fuel gauge specifically assume a 103AT-2 type thermistor profile and so that is the default recommendation for thermistor selection purposes. Moving to a separate thermistor resistance profile (for example, JT-2 or others) requires an update to the default thermistor coefficients in data flash to ensure highest accuracy temperature measurement performance.

9.2.2.6 REGIN Power Supply Input Filtering

A ceramic capacitor is placed at the input to the fuel gauge internal LDO to increase power supply rejection (PSR) and improve effective line regulation. It ensures that voltage ripple is rejected to ground instead of coupling into the internal supply rails of the fuel gauge.

9.2.2.7 V_{CC} LDO Output Filtering

A ceramic capacitor is also needed at the output of the internal LDO to provide a current reservoir for fuel gauge load peaks during high peripheral utilization. It acts to stabilize the regulator output and reduce core voltage ripple inside of the fuel gauge.

9.2.3 Application Curves

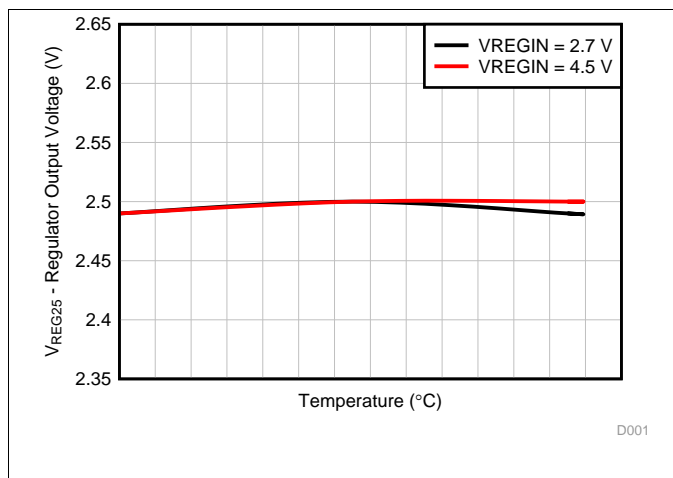

Figure 13. Regulator Output Voltage vs. Temperature

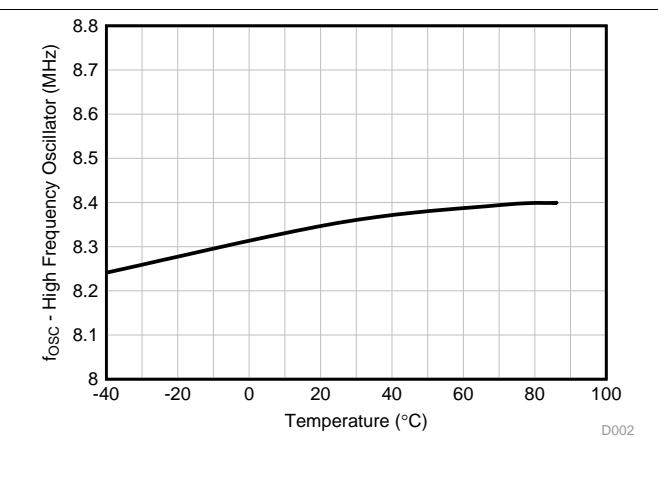

Figure 14. High-Frequency Oscillator Frequency vs. Temperature

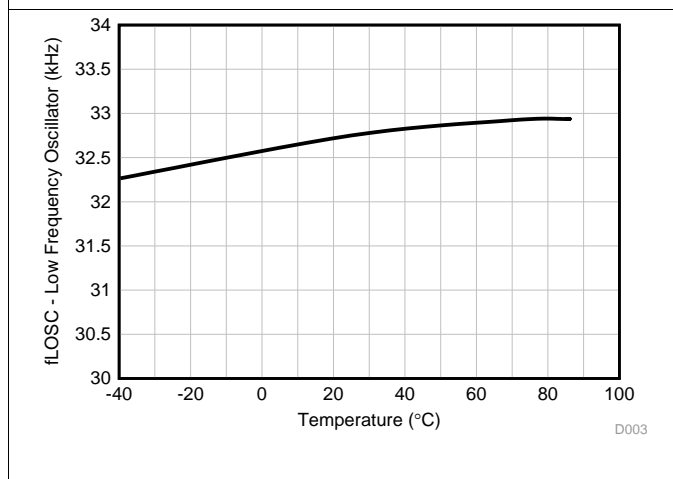

Figure 15. Low-Frequency Oscillator Frequency vs. Temperature

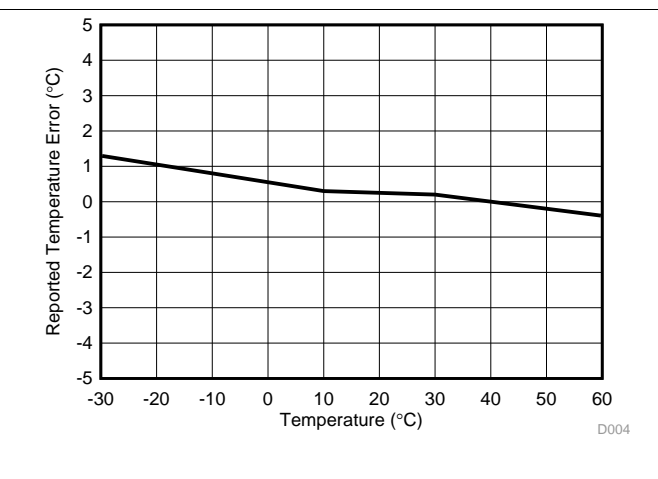

Figure 16. Reported Internal Temperature Measurement vs. Temperature

10 Power Supply Recommendations

10.1 Power Supply Decoupling

Both the REGIN input pin and the V_{CC} output pin require low equivalent series resistance (ESR) ceramic capacitors placed as closely as possible to the respective pins to optimize ripple rejection and provide a stable and dependable power rail that is resilient to line transients. A 0.1- μ F capacitor at the REGIN and a 1- μ F capacitor at V_{CC} will suffice for satisfactory device performance.

11 Layout

11.1 Layout Guidelines

11.1.1 Sense Resistor Connections

Kelvin connections at the sense resistor are just as critical as those for the battery terminals themselves. The differential traces should be connected at the inside of the sense resistor pads and not anywhere along the high-current trace path to prevent false increases to measured current that could result when measuring between the sum of the sense resistor and trace resistance between the tap points. In addition, the routing of these leads from the sense resistor to the input filter network and finally into the SRP and SRN pins needs to be as closely matched in length as possible else additional measurement offset could occur. It is further recommended to add copper trace or pour-based "guard rings" around the perimeter of the filter network and coulomb counter inputs to shield these sensitive pins from radiated EMI into the sense nodes. This prevents differential voltage shifts that could be interpreted as real current change to the fuel gauge. All of the filter components need to be placed as close as possible to the coulomb counter input pins.

11.1.2 Thermistor Connections

The thermistor sense input should include a ceramic bypass capacitor placed as close to the TS input pin as possible. The capacitor helps to filter measurements of any stray transients as the voltage bias circuit pulses periodically during temperature sensing windows.

11.1.3 High-Current and Low-Current Path Separation

For best possible noise performance, it is extremely important to separate the low-current and high-current loops to different areas of the board layout. The fuel gauge and all support components should be situated on one side of the boards and tap off of the high-current loop (for measurement purposes) at the sense resistor. Routing the low-current ground around instead of under high-current traces will further help to improve noise rejection.

11.2 Layout Example

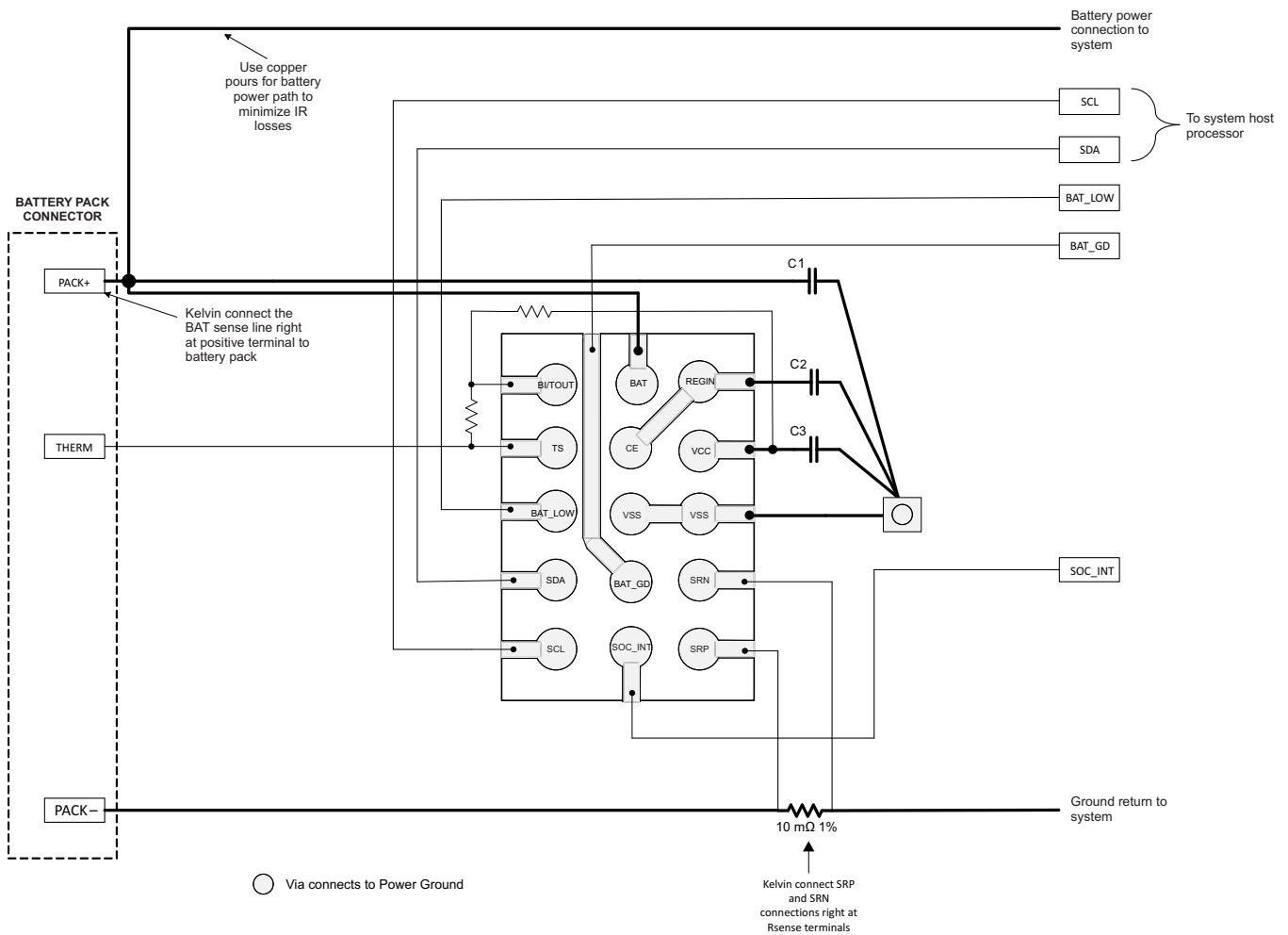

Figure 17. Layout Recommendation

12 Device and Documentation Support

12.1 Documentation Support

12.1.1 Related Documentation

To obtain a copy of any of the following TI documents, call the Texas Instruments Literature Response Center at (800) 477-8924 or the Product Information Center (PIC) at (972) 644-5580. When ordering, identify this document by its title and literature number. Updated documents also can be obtained through the TI Web site at www.ti.com.

- *bq27520-G4 Technical Reference Manual*, [SLUUA35](#)

12.2 Community Resources

The following links connect to TI community resources. Linked contents are provided "AS IS" by the respective contributors. They do not constitute TI specifications and do not necessarily reflect TI's views; see TI's [Terms of Use](#).

TI E2E™ Online Community *TI's Engineer-to-Engineer (E2E) Community*. Created to foster collaboration among engineers. At e2e.ti.com, you can ask questions, share knowledge, explore ideas and help solve problems with fellow engineers.

Design Support *TI's Design Support* Quickly find helpful E2E forums along with design support tools and contact information for technical support.

12.3 Trademarks

Impedance Track, NanoFree, E2E are trademarks of Texas Instruments. All other trademarks are the property of their respective owners.

12.4 Electrostatic Discharge Caution



These devices have limited built-in ESD protection. The leads should be shorted together or the device placed in conductive foam during storage or handling to prevent electrostatic damage to the MOS gates.

12.5 Glossary

[SLYZ022](#) — *TI Glossary*.

This glossary lists and explains terms, acronyms, and definitions.

13 Mechanical, Packaging, and Orderable Information

The following pages include mechanical, packaging, and orderable information. This information is the most current data available for the designated devices. This data is subject to change without notice and revision of this document. For browser-based versions of this data sheet, refer to the left-hand navigation.

PACKAGING INFORMATION

| Orderable Device | Status (1) | Package Type | Package Drawing | Pins | Package Qty | Eco Plan (2) | Lead/Ball Finish (6) | MSL Peak Temp (3) | Op Temp (°C) | Device Marking (4/5) | Samples |
|------------------|---------------|--------------|-----------------|------|-------------|-------------------------|-------------------------|----------------------|--------------|-------------------------|-------------------------|
| BQ27520YZFR-G4 | ACTIVE | DSBGA | YZF | 15 | 3000 | Green (RoHS & no Sb/Br) | SNAGCU | Level-1-260C-UNLIM | -40 to 85 | BQ27520 | Samples |
| BQ27520YZFT-G4 | ACTIVE | DSBGA | YZF | 15 | 250 | Green (RoHS & no Sb/Br) | SNAGCU | Level-1-260C-UNLIM | -40 to 85 | BQ27520 | Samples |
| HPA02254YZFR | ACTIVE | DSBGA | YZF | 15 | 3000 | Green (RoHS & no Sb/Br) | SNAGCU | Level-1-260C-UNLIM | -40 to 85 | BQ27520 | Samples |

(1) The marketing status values are defined as follows:

ACTIVE: Product device recommended for new designs.

LIFEBUY: TI has announced that the device will be discontinued, and a lifetime-buy period is in effect.

NRND: Not recommended for new designs. Device is in production to support existing customers, but TI does not recommend using this part in a new design.

PREVIEW: Device has been announced but is not in production. Samples may or may not be available.

OBsolete: TI has discontinued the production of the device.

(2) Eco Plan - The planned eco-friendly classification: Pb-Free (RoHS), Pb-Free (RoHS Exempt), or Green (RoHS & no Sb/Br) - please check <http://www.ti.com/productcontent> for the latest availability information and additional product content details.

TBD: The Pb-Free/Green conversion plan has not been defined.

Pb-Free (RoHS): TI's terms "Lead-Free" or "Pb-Free" mean semiconductor products that are compatible with the current RoHS requirements for all 6 substances, including the requirement that lead not exceed 0.1% by weight in homogeneous materials. Where designed to be soldered at high temperatures, TI Pb-Free products are suitable for use in specified lead-free processes.

Pb-Free (RoHS Exempt): This component has a RoHS exemption for either 1) lead-based flip-chip solder bumps used between the die and package, or 2) lead-based die adhesive used between the die and leadframe. The component is otherwise considered Pb-Free (RoHS compatible) as defined above.

Green (RoHS & no Sb/Br): TI defines "Green" to mean Pb-Free (RoHS compatible), and free of Bromine (Br) and Antimony (Sb) based flame retardants (Br or Sb do not exceed 0.1% by weight in homogeneous material)

(3) MSL, Peak Temp. - The Moisture Sensitivity Level rating according to the JEDEC industry standard classifications, and peak solder temperature.

(4) There may be additional marking, which relates to the logo, the lot trace code information, or the environmental category on the device.

(5) Multiple Device Markings will be inside parentheses. Only one Device Marking contained in parentheses and separated by a "~" will appear on a device. If a line is indented then it is a continuation of the previous line and the two combined represent the entire Device Marking for that device.

(6) Lead/Ball Finish - Orderable Devices may have multiple material finish options. Finish options are separated by a vertical ruled line. Lead/Ball Finish values may wrap to two lines if the finish value exceeds the maximum column width.

Important Information and Disclaimer: The information provided on this page represents TI's knowledge and belief as of the date that it is provided. TI bases its knowledge and belief on information provided by third parties, and makes no representation or warranty as to the accuracy of such information. Efforts are underway to better integrate information from third parties. TI has taken and

continues to take reasonable steps to provide representative and accurate information but may not have conducted destructive testing or chemical analysis on incoming materials and chemicals. TI and TI suppliers consider certain information to be proprietary, and thus CAS numbers and other limited information may not be available for release.

In no event shall TI's liability arising out of such information exceed the total purchase price of the TI part(s) at issue in this document sold by TI to Customer on an annual basis.

TAPE AND REEL INFORMATION

QUADRANT ASSIGNMENTS FOR PIN 1 ORIENTATION IN TAPE

*All dimensions are nominal

| Device | Package Type | Package Drawing | Pins | SPQ | Reel Diameter (mm) | Reel Width W1 (mm) | A0 (mm) | B0 (mm) | K0 (mm) | P1 (mm) | W (mm) | Pin1 Quadrant |
|----------------|--------------|-----------------|------|------|--------------------|--------------------|---------|---------|---------|---------|--------|---------------|
| BQ27520YZFR-G4 | DSBGA | YZF | 15 | 3000 | 180.0 | 8.4 | 2.1 | 2.76 | 0.81 | 4.0 | 8.0 | Q1 |
| BQ27520YZFT-G4 | DSBGA | YZF | 15 | 250 | 180.0 | 8.4 | 2.1 | 2.76 | 0.81 | 4.0 | 8.0 | Q1 |

TAPE AND REEL BOX DIMENSIONS

*All dimensions are nominal

| Device | Package Type | Package Drawing | Pins | SPQ | Length (mm) | Width (mm) | Height (mm) |
|----------------|--------------|-----------------|------|------|-------------|------------|-------------|
| BQ27520YZFR-G4 | DSBGA | YZF | 15 | 3000 | 182.0 | 182.0 | 20.0 |
| BQ27520YZFT-G4 | DSBGA | YZF | 15 | 250 | 182.0 | 182.0 | 20.0 |

YZF0015

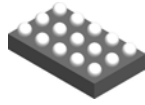

PACKAGE OUTLINE

DSBGA - 0.625 mm max height

DIE SIZE BALL GRID ARRAY

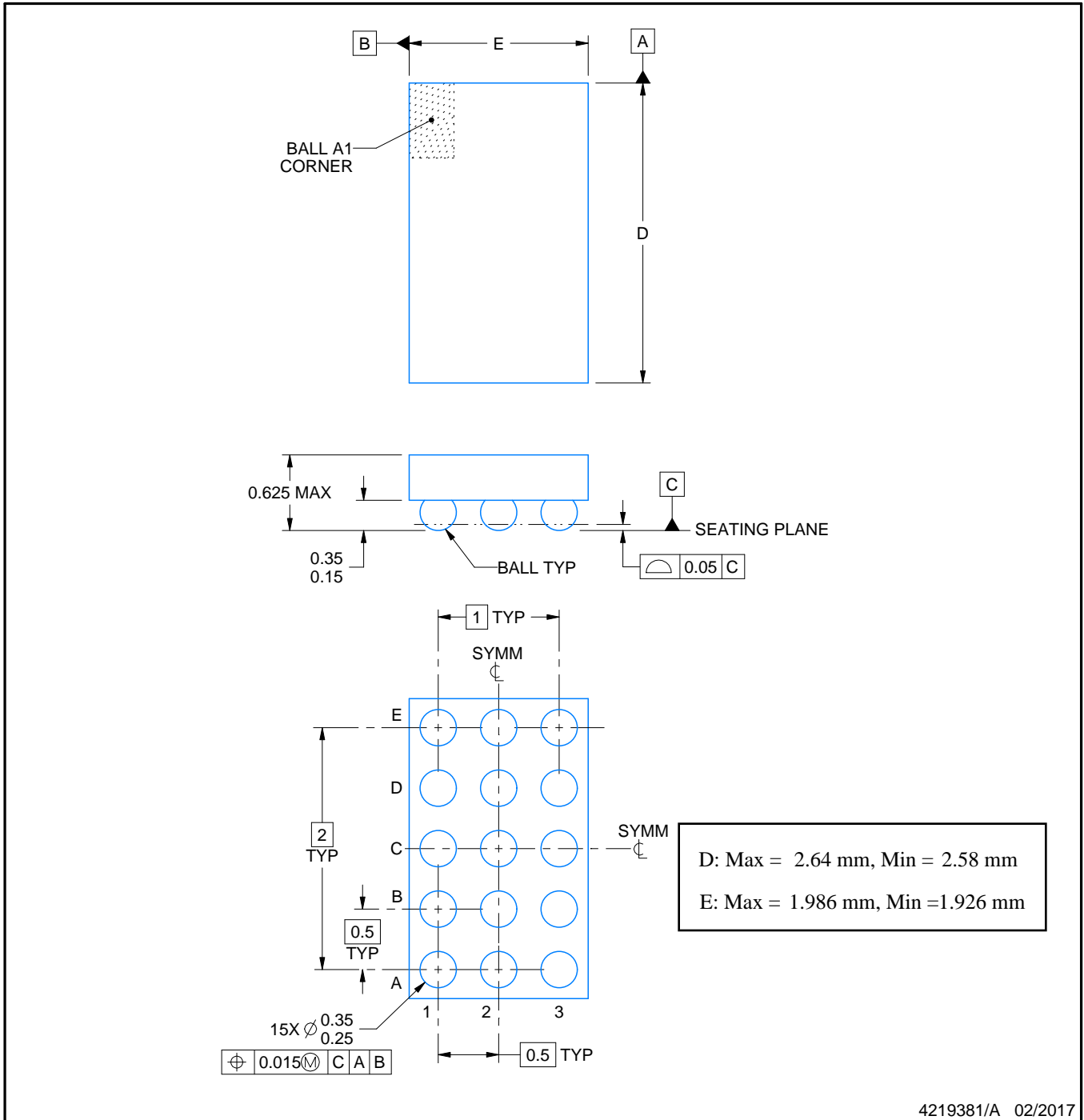

4219381/A 02/2017

NOTES:

NanoFree Is a trademark of Texas Instruments.

1. All linear dimensions are in millimeters. Any dimensions in parenthesis are for reference only. Dimensioning and tolerancing per ASME Y14.5M.
2. This drawing is subject to change without notice.
3. NanoFree™ package configuration.

EXAMPLE BOARD LAYOUT

YZF0015

DSBGA - 0.625 mm max height

DIE SIZE BALL GRID ARRAY

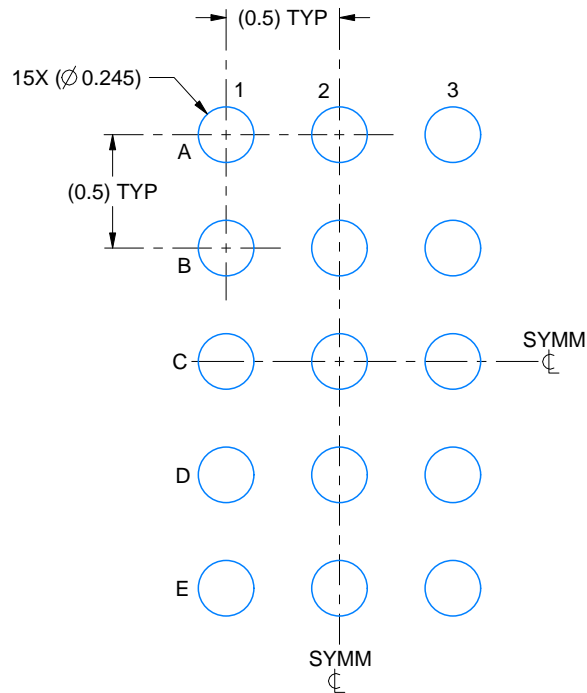

LAND PATTERN EXAMPLE
EXPOSED METAL SHOWN
SCALE:30X

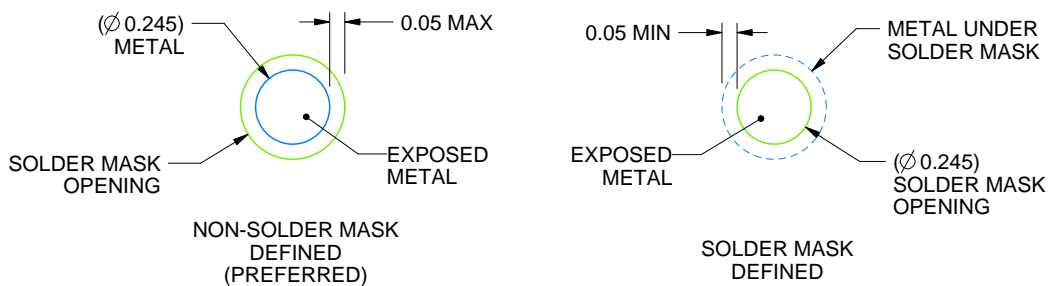

SOLDER MASK DETAILS
NOT TO SCALE

4219381/A 02/2017

NOTES: (continued)

- Final dimensions may vary due to manufacturing tolerance considerations and also routing constraints. For more information, see Texas Instruments literature number SNVA009 (www.ti.com/lit/snva009).

EXAMPLE STENCIL DESIGN

YZF0015

DSBGA - 0.625 mm max height

DIE SIZE BALL GRID ARRAY

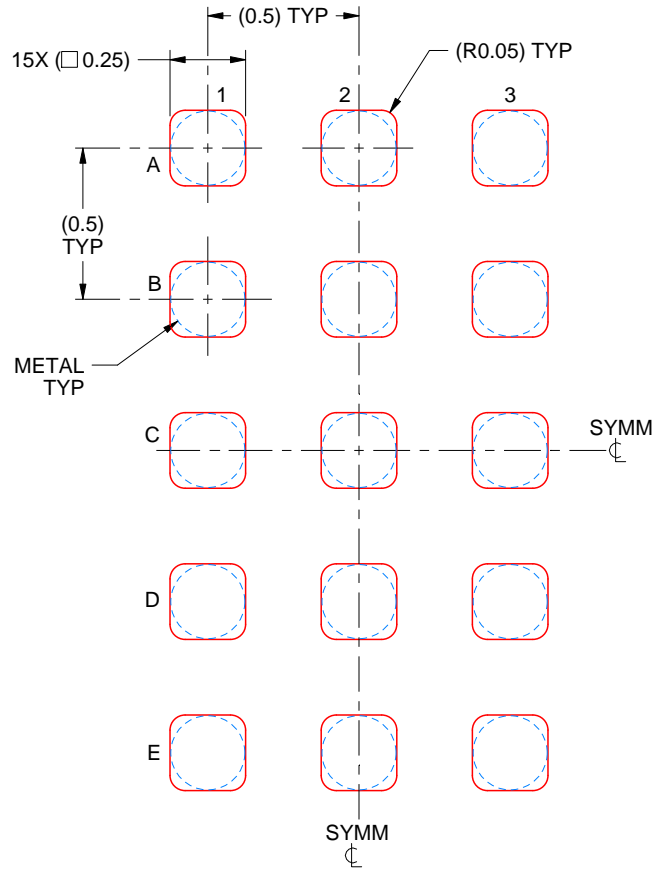

SOLDER PASTE EXAMPLE
BASED ON 0.1 mm THICK STENCIL
SCALE:40X

4219381/A 02/2017

NOTES: (continued)

5. Laser cutting apertures with trapezoidal walls and rounded corners may offer better paste release.

IMPORTANT NOTICE

Texas Instruments Incorporated (TI) reserves the right to make corrections, enhancements, improvements and other changes to its semiconductor products and services per JESD46, latest issue, and to discontinue any product or service per JESD48, latest issue. Buyers should obtain the latest relevant information before placing orders and should verify that such information is current and complete.

TI's published terms of sale for semiconductor products (<http://www.ti.com/sc/docs/stdterms.htm>) apply to the sale of packaged integrated circuit products that TI has qualified and released to market. Additional terms may apply to the use or sale of other types of TI products and services.

Reproduction of significant portions of TI information in TI data sheets is permissible only if reproduction is without alteration and is accompanied by all associated warranties, conditions, limitations, and notices. TI is not responsible or liable for such reproduced documentation. Information of third parties may be subject to additional restrictions. Resale of TI products or services with statements different from or beyond the parameters stated by TI for that product or service voids all express and any implied warranties for the associated TI product or service and is an unfair and deceptive business practice. TI is not responsible or liable for any such statements.

Buyers and others who are developing systems that incorporate TI products (collectively, "Designers") understand and agree that Designers remain responsible for using their independent analysis, evaluation and judgment in designing their applications and that Designers have full and exclusive responsibility to assure the safety of Designers' applications and compliance of their applications (and of all TI products used in or for Designers' applications) with all applicable regulations, laws and other applicable requirements. Designer represents that, with respect to their applications, Designer has all the necessary expertise to create and implement safeguards that (1) anticipate dangerous consequences of failures, (2) monitor failures and their consequences, and (3) lessen the likelihood of failures that might cause harm and take appropriate actions. Designer agrees that prior to using or distributing any applications that include TI products, Designer will thoroughly test such applications and the functionality of such TI products as used in such applications.

TI's provision of technical, application or other design advice, quality characterization, reliability data or other services or information, including, but not limited to, reference designs and materials relating to evaluation modules, (collectively, "TI Resources") are intended to assist designers who are developing applications that incorporate TI products; by downloading, accessing or using TI Resources in any way, Designer (individually or, if Designer is acting on behalf of a company, Designer's company) agrees to use any particular TI Resource solely for this purpose and subject to the terms of this Notice.

TI's provision of TI Resources does not expand or otherwise alter TI's applicable published warranties or warranty disclaimers for TI products, and no additional obligations or liabilities arise from TI providing such TI Resources. TI reserves the right to make corrections, enhancements, improvements and other changes to its TI Resources. TI has not conducted any testing other than that specifically described in the published documentation for a particular TI Resource.

Designer is authorized to use, copy and modify any individual TI Resource only in connection with the development of applications that include the TI product(s) identified in such TI Resource. NO OTHER LICENSE, EXPRESS OR IMPLIED, BY ESTOPPEL OR OTHERWISE TO ANY OTHER TI INTELLECTUAL PROPERTY RIGHT, AND NO LICENSE TO ANY TECHNOLOGY OR INTELLECTUAL PROPERTY RIGHT OF TI OR ANY THIRD PARTY IS GRANTED HEREIN, including but not limited to any patent right, copyright, mask work right, or other intellectual property right relating to any combination, machine, or process in which TI products or services are used. Information regarding or referencing third-party products or services does not constitute a license to use such products or services, or a warranty or endorsement thereof. Use of TI Resources may require a license from a third party under the patents or other intellectual property of the third party, or a license from TI under the patents or other intellectual property of TI.

TI RESOURCES ARE PROVIDED "AS IS" AND WITH ALL FAULTS. TI DISCLAIMS ALL OTHER WARRANTIES OR REPRESENTATIONS, EXPRESS OR IMPLIED, REGARDING RESOURCES OR USE THEREOF, INCLUDING BUT NOT LIMITED TO ACCURACY OR COMPLETENESS, TITLE, ANY EPIDEMIC FAILURE WARRANTY AND ANY IMPLIED WARRANTIES OF MERCHANTABILITY, FITNESS FOR A PARTICULAR PURPOSE, AND NON-INFRINGEMENT OF ANY THIRD PARTY INTELLECTUAL PROPERTY RIGHTS. TI SHALL NOT BE LIABLE FOR AND SHALL NOT DEFEND OR INDEMNIFY DESIGNER AGAINST ANY CLAIM, INCLUDING BUT NOT LIMITED TO ANY INFRINGEMENT CLAIM THAT RELATES TO OR IS BASED ON ANY COMBINATION OF PRODUCTS EVEN IF DESCRIBED IN TI RESOURCES OR OTHERWISE. IN NO EVENT SHALL TI BE LIABLE FOR ANY ACTUAL, DIRECT, SPECIAL, COLLATERAL, INDIRECT, PUNITIVE, INCIDENTAL, CONSEQUENTIAL OR EXEMPLARY DAMAGES IN CONNECTION WITH OR ARISING OUT OF TI RESOURCES OR USE THEREOF, AND REGARDLESS OF WHETHER TI HAS BEEN ADVISED OF THE POSSIBILITY OF SUCH DAMAGES.

Unless TI has explicitly designated an individual product as meeting the requirements of a particular industry standard (e.g., ISO/TS 16949 and ISO 26262), TI is not responsible for any failure to meet such industry standard requirements.

Where TI specifically promotes products as facilitating functional safety or as compliant with industry functional safety standards, such products are intended to help enable customers to design and create their own applications that meet applicable functional safety standards and requirements. Using products in an application does not by itself establish any safety features in the application. Designers must ensure compliance with safety-related requirements and standards applicable to their applications. Designer may not use any TI products in life-critical medical equipment unless authorized officers of the parties have executed a special contract specifically governing such use. Life-critical medical equipment is medical equipment where failure of such equipment would cause serious bodily injury or death (e.g., life support, pacemakers, defibrillators, heart pumps, neurostimulators, and implantables). Such equipment includes, without limitation, all medical devices identified by the U.S. Food and Drug Administration as Class III devices and equivalent classifications outside the U.S.

TI may expressly designate certain products as completing a particular qualification (e.g., Q100, Military Grade, or Enhanced Product). Designers agree that it has the necessary expertise to select the product with the appropriate qualification designation for their applications and that proper product selection is at Designers' own risk. Designers are solely responsible for compliance with all legal and regulatory requirements in connection with such selection.

Designer will fully indemnify TI and its representatives against any damages, costs, losses, and/or liabilities arising out of Designer's non-compliance with the terms and provisions of this Notice.

Looking for pricing, stock, or lifecycle information?

Click below to explore more details on WIN SOURCE:

 [View BQ27520YZFT-G4](#) on WIN SOURCE

 [Texas Instruments](#) Information

Optimize Your Supply Chain with WIN SOURCE Solutions

-  Global Sourcing Solution
-  Obsolete Management
-  Cost Control Management
-  Shortage Management
-  Alternative Solution
-  Excess Inventory Management