



**THE DATASHEET OF
BQ27510DRZR-G3**



bq27510-G3 System-Side Impedance Track™ Fuel Gauge With Direct Battery Connection

1 Features

- Single-Series Cell Li-Ion Battery Fuel Gauge Resides on System Board
 - Integrated 2.5-VDC LDO
 - External Low-Value 10-mΩ Sense Resistor
- Patented Impedance Track™ Technology
 - Adjusts for Battery Aging, Self-Discharge, Temperature, and Rate Changes
 - Reports Remaining Capacity, State-of-Charge (SOC), and Time-to-Empty
 - Optional Smoothing Filter
 - Battery State-of-Health (Aging) Estimation
 - Supports Embedded or Removable Packs With up to 32-Ahr Capacity
 - Accommodates Pack Swapping With 2 Separate Battery Profiles
- Microcontroller Peripheral Supports:
 - 400-kHz I²C Serial Interface
 - 32 Bytes of Scratch-Pad FLASH NVM
 - Battery Low Digital Output Warning
 - Configurable SOC Interrupts
 - External Thermistor, Internal Sensor, or Host-Reported Temperature Options
- Small 12-Pin 2.50 mm × 4.00 mm SON Package

2 Applications

- Smartphones, Feature Phones, and Tablets
- Wearables
- Building Automation
- Portable Medical/Industrial Handsets
- Portable Audio
- Gaming

3 Description

The Texas Instruments bq27510-G3 system-side Li-ion battery fuel gauge is a microcontroller peripheral that provides fuel gauging for single-cell Li-ion battery packs. The device requires little system microcontroller firmware development. The bq27510-G3 resides on the system's main board and manages an embedded battery (non-removable) or a removable battery pack.

The bq27510-G3 uses the patented Impedance Track™ algorithm for fuel gauging, and provides information such as remaining battery capacity (mAh), state-of-charge (%), run-time to empty (min.), battery voltage (mV), temperature (°C) and state-of-health (%).

Battery fuel gauging with the bq27510-G3 requires only PACK+ (P+), PACK– (P–), and optional Thermistor (T) connections to a removable battery pack or embedded battery circuit.

Device Information⁽¹⁾

PART NUMBER	PACKAGE	FIRMWARE VERSION
bq27510-G3	SON (12)	4.00 (0X0400)

(1) For all available packages, see the orderable addendum at the end of the data sheet.

Typical Application Diagram

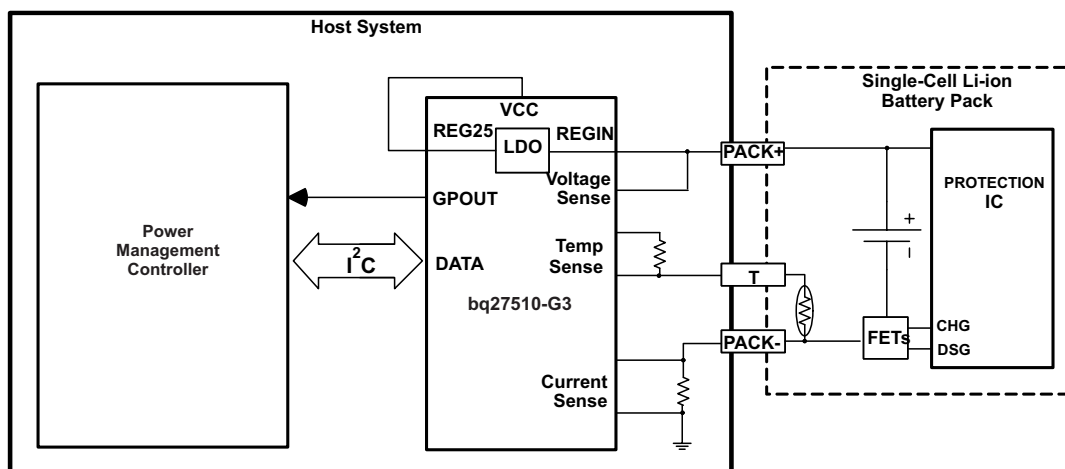

Table of Contents

1 Features	1	7.3 Feature Description.....	10
2 Applications	1	7.4 Device Functional Modes.....	10
3 Description	1	7.5 Programming.....	13
4 Revision History	2	8 Application and Implementation	17
5 Pin Configuration and Functions	3	8.1 Application Information.....	17
6 Specifications	3	8.2 Typical Application	17
6.1 Absolute Maximum Ratings	3	9 Power Supply Recommendations	20
6.2 ESD Ratings.....	4	9.1 Power Supply Decoupling.....	20
6.3 Recommended Operating Conditions.....	4	10 Layout	21
6.4 Thermal Information	4	10.1 Layout Guidelines	21
6.5 Electrical Characteristics	5	10.2 Layout Example	21
6.6 Data Flash Memory Characteristics.....	6	11 Device and Documentation Support	22
6.7 400-kHz I ² C-Compatible Interface Communication Timing Requirements.....	6	11.1 Device Support	22
6.8 100-kHz I ² C-Compatible Interface Communication Timing Requirements.....	6	11.2 Documentation Support	22
6.9 Typical Characteristics.....	7	11.3 Community Resources.....	22
7 Detailed Description	8	11.4 Trademarks	22
7.1 Overview	8	11.5 Electrostatic Discharge Caution.....	22
7.2 Functional Block Diagram	9	11.6 Glossary	22
		12 Mechanical, Packaging, and Orderable Information	22

4 Revision History

NOTE: Page numbers for previous revisions may differ from page numbers in the current version.

Changes from Original (March 2013) to Revision A

Page

- Added *ESD Ratings* table, *Feature Description* section, *Device Functional Modes*, *Application and Implementation* section, *Power Supply Recommendations* section, *Layout* section, *Device and Documentation Support* section, and *Mechanical, Packaging, and Orderable Information* section. **1**

5 Pin Configuration and Functions

**DRZ Package
12-Pin SON
Top View**

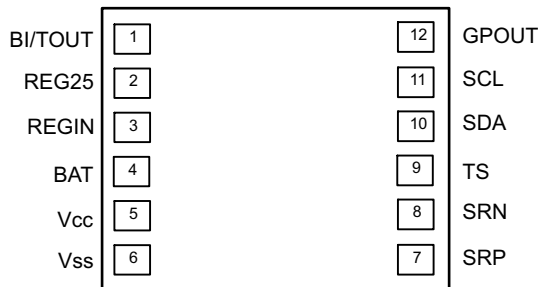

Pin Functions

PIN		TYPE ⁽¹⁾	DESCRIPTION
NAME	NO.		
BI/TOUT	1	I/O	Battery-insertion detection input. Power pin for pack thermistor network. Thermistor-multiplexer control pin. Open-drain I/O. Use with pull-up resistor >1MΩ (1.8 MΩ typical).
REG25	2	P	2.5 V output voltage of the internal integrated LDO.
REGIN	3	P	Regulator input. Decouple with 0.1-μF ceramic capacitor to V _{SS} .
BAT	4	I	Cell voltage measurement input. ADC input.
V _{CC}	5	P	Processor power input. Decouple with 0.1-μF ceramic capacitor minimum.
V _{SS}	6	P	Device ground
SRP	7	IA	Analog input pin connected to the internal coulomb counter with a Kelvin connection where SRP is nearest the PACK– connection. Connect to 5-mΩ to 20-mΩ sense resistor.
SRN	8	IA	Analog input pin connected to the internal coulomb counter with a Kelvin connection where SRN is nearest the V _{SS} connection. Connect to 5-mΩ to 20-mΩ sense resistor.
TS	9	IA	Pack thermistor voltage sense (use 103AT-type thermistor). ADC input
SDA	10	I/O	Slave I ² C serial communications data line for communication with system (Master). Open-drain I/O. Use with 10-kΩ pull-up resistor (typical).
SCL	11	I	Slave I ² C serial communications clock input line for communication with system (Master). Open-drain I/O. Use with 10-kΩ pull-up resistor (typical).
GPOUT	12	O	General Purpose open-drain output. May be configured as Battery Low, Battery Good, or to perform interrupt functionality.

(1) I/O = Digital input/output; IA = Analog input; P = Power connection.

6 Specifications

6.1 Absolute Maximum Ratings

over operating free-air temperature range (unless otherwise noted)⁽¹⁾

		MIN	MAX	UNIT
V _{REGIN}	Regulator input voltage	–0.3	24	V
V _{CC}	Supply voltage	–0.3	2.75	V
V _{IOD}	Open-drain I/O pins (SDA, SCL, GPOUT)	–0.3	6	V
V _{BAT}	BAT input pin	–0.3	6	V
V _I	Input voltage to all other pins (TS, SRP, SRN, BI/TOUT)	–0.3	V _{CC} + 0.3	V
T _F	Functional temperature	–40	100	°C
T _{stg}	Storage temperature	–65	150	°C

(1) Stresses beyond those listed under *Absolute Maximum Ratings* may cause permanent damage to the device. These are stress ratings only, which do not imply functional operation of the device at these or any other conditions beyond those indicated under *Recommended Operating Conditions*. Exposure to absolute-maximum-rated conditions for extended periods may affect device reliability.

6.2 ESD Ratings

			VALUE	UNIT	
V _(ESD)	Electrostatic discharge	Human-body model (HBM), per ANSI/ESDA/JEDEC JS-001 ⁽¹⁾	All pins except pin 4	±2000	V
			Pin 4	±1500	
		Charged-device model (CDM), per JEDEC specification JESD22-C101 ⁽²⁾		±250	

(1) JEDEC document JEP155 states that 500-V HBM allows safe manufacturing with a standard ESD control process.

(2) JEDEC document JEP157 states that 250-V CDM allows safe manufacturing with a standard ESD control process.

6.3 Recommended Operating Conditions

T_A = 25°C, V_{CC} = 2.5 V (unless otherwise noted)

			MIN	NOM	MAX	UNIT
V _{REGIN}	Supply voltage	No operating restrictions	2.7		5.5	V
		No FLASH writes	2.45		2.7	
C _{REG25}	External REG25 capacitor	C _{REG25}	0.47			μF
t _{PUCD}	Power Up Communication Delay			250		ms
I _{CC}	Normal operating mode current	Fuel gauge in NORMAL mode. I _{LOAD} > Sleep Current		103		μA
I _{SLP}	Low-power operating mode current	Fuel gauge in SLEEP mode. I _{LOAD} < Sleep Current		18		μA
I _{SLP+}	Low-power operating mode current	Fuel gauge in SLEEP+ mode. I _{LOAD} < Sleep Current		60		μA
I _{HIB}	Hibernate operating mode current	Fuel gauge in HIBERNATE mode. I _{LOAD} < Hibernate Current		4		μA
V _{OL}	Output voltage low (SDA, GPOUT, BI/TOUT)	I _{OL} = 0.5 mA			0.4	V
V _{OH(PP)}	Output high voltage (GPOUT)	I _{OH} = -1 mA	V _{CC} -0.5			V
V _{OH(OD)}	Output high voltage (SDA, SCL, BI/TOUT)	External pull-up resistor connected to V _{CC}	V _{CC} -0.5			V
V _{IL}	Input voltage low (SDA, SCL)		-0.3		0.6	V
	Input voltage low (BI/TOUT)	BAT INSERT CHECK MODE active	-0.3		0.6	
V _{IH(OD)}	Input voltage high (SDA, SCL)		1.2		6	V
	Input voltage high (BI/TOUT)	BAT INSERT CHECK MODE active	1.2		6	
V _{A1}	Input voltage range (TS)		V _{SS} -0.125		2	V
V _{A2}	Input voltage range (BAT)		V _{SS} -0.125		5	V
V _{A3}	Input voltage range (SRP, SRN)		V _{SS} -0.125		0.125	V
t _{PUCD}	Power-up communication delay			250		ms
T _A	Operating free-air temperature		-40		85	°C

6.4 Thermal Information

THERMAL METRIC ⁽¹⁾		bq27510-G3	UNIT
		DRZ (SON)	
		12 PINS	
R _{θJA}	Junction-to-ambient thermal resistance	64.1	°C/W
R _{θJC(top)}	Junction-to-case (top) thermal resistance	59.8	°C/W
R _{θJB}	Junction-to-board thermal resistance	52.7	°C/W
ψ _{JT}	Junction-to-top characterization parameter	0.3	°C/W
ψ _{JB}	Junction-to-board characterization parameter	28.3	°C/W
R _{θJC(bot)}	Junction-to-case (bottom) thermal resistance	2.4	°C/W

(1) For more information about traditional and new thermal metrics, see the *Semiconductor and IC Package Thermal Metrics* application report, [SPRA953](#).

6.5 Electrical Characteristics

 $T_A = 25^\circ\text{C}$, $C_{\text{REG}} = 0.47 \mu\text{F}$, $V_{\text{REGIN}} = 3.6 \text{ V}$ (unless otherwise noted)

PARAMETER		TEST CONDITION	MIN	NOM	MAX	UNIT		
2.5-V LDO⁽¹⁾								
V_{REG25}	Regulator output voltage	$2.7 \text{ V} \leq V_{\text{REGIN}} \leq 5.5 \text{ V}$, $I_{\text{OUT}} \leq 16 \text{ mA}$	$T_A = -40^\circ\text{C}$ to 85°C		2.4	2.5	2.6	V
		$2.45 \text{ V} \leq V_{\text{REGIN}} < 2.7 \text{ V}$ (low battery), $I_{\text{OUT}} \leq 3 \text{ mA}$	$T_A = -40^\circ\text{C}$ to 85°C		2.4			V
V_{DO}	Regulator dropout voltage	2.7 V , $I_{\text{OUT}} \leq 16 \text{ mA}$	$T_A = -40^\circ\text{C}$ to 85°C			280	mV	
		2.45 V , $I_{\text{OUT}} \leq 3 \text{ mA}$				50		
$\Delta V_{\text{REGTEMP}}$	Regulator output change with temperature	$V_{\text{REGIN}} = 3.6 \text{ V}$, $I_{\text{OUT}} = 16 \text{ mA}$	$T_A = -40^\circ\text{C}$ to 85°C		0.3%			
$\Delta V_{\text{REGLINE}}$	Line regulation	$2.7 \text{ V} \leq V_{\text{REGIN}} \leq 5.5 \text{ V}$, $I_{\text{OUT}} = 16 \text{ mA}$			11	25	mV	
$\Delta V_{\text{REGLOAD}}$	Load regulation	$0.2 \text{ mA} \leq I_{\text{OUT}} \leq 3 \text{ mA}$, $V_{\text{REGIN}} = 2.45 \text{ V}$			34	40	mV	
		$3 \text{ mA} \leq I_{\text{OUT}} \leq 16 \text{ mA}$, $V_{\text{REGIN}} = 2.7 \text{ V}$			31			
$I_{\text{SHORT}}^{(2)}$	Short circuit current limit	$V_{\text{REG25}} = 0 \text{ V}$	$T_A = -40^\circ\text{C}$ to 85°C			250	mA	
POWER-ON RESET								
$V_{\text{IT+}}$	Positive-going battery voltage input at V_{CC}	$T_A = -40^\circ\text{C}$ to 85°C			2.05	2.20	2.31	V
V_{HYS}	Power-on reset hysteresis	$T_A = -40^\circ\text{C}$ to 85°C			45	115	185	mV
INTERNAL TEMPERATURE SENSOR CHARACTERISTICS								
G_{TEMP}	Temperature sensor voltage gain	$T_A = -40^\circ\text{C}$ to 85°C , $2.4 \text{ V} < V_{\text{CC}} < 2.6 \text{ V}$; typical values at $T_A = 25^\circ\text{C}$ and $V_{\text{CC}} = 2.5 \text{ V}$			-2		mV/ $^\circ\text{C}$	
INTERNAL CLOCK OSCILLATORS								
f_{OSC}	High Frequency Oscillator	$T_A = -40^\circ\text{C}$ to 85°C , $2.4 \text{ V} < V_{\text{CC}} < 2.6 \text{ V}$; typical values at $T_A = 25^\circ\text{C}$ and $V_{\text{CC}} = 2.5 \text{ V}$			8.389		MHz	
f_{LOSC}	Low Frequency Oscillator	$T_A = -40^\circ\text{C}$ to 85°C , $2.4 \text{ V} < V_{\text{CC}} < 2.6 \text{ V}$; typical values at $T_A = 25^\circ\text{C}$ and $V_{\text{CC}} = 2.5 \text{ V}$			32.768		kHz	
INTEGRATING ADC (COULOMB COUNTER) CHARACTERISTICS								
$V_{\text{SR_IN}}$	Input voltage range, $V_{\text{(SRN)}}$ and $V_{\text{(SRP)}}$	$V_{\text{SR}} = V_{\text{(SRN)}} - V_{\text{(SRP)}}$	$T_A = -40^\circ\text{C}$ to 85°C , $2.4 \text{ V} < V_{\text{CC}} < 2.6 \text{ V}$		-0.125	0.125		V
$t_{\text{SR_CONV}}$	Conversion time	Single conversion	$T_A = 25^\circ\text{C}$ and $V_{\text{CC}} = 2.5 \text{ V}$			1		s
	Resolution	$T_A = -40^\circ\text{C}$ to 85°C , $2.4 \text{ V} < V_{\text{CC}} < 2.6 \text{ V}$			14	15		bits
$V_{\text{SR_OS}}$	Input offset	$T_A = 25^\circ\text{C}$ and $V_{\text{CC}} = 2.5 \text{ V}$			10		μV	
I_{NL}	Integral nonlinearity error	$T_A = -40^\circ\text{C}$ to 85°C , $2.4 \text{ V} < V_{\text{CC}} < 2.6 \text{ V}$			± 0.007	± 0.034		%FSR
$Z_{\text{SR_IN}}$	Effective input resistance ⁽²⁾	$T_A = -40^\circ\text{C}$ to 85°C , $2.4 \text{ V} < V_{\text{CC}} < 2.6 \text{ V}$			2.5		M Ω	
$I_{\text{SR_LKG}}$	Input leakage current ⁽²⁾	$T_A = -40^\circ\text{C}$ to 85°C , $2.4 \text{ V} < V_{\text{CC}} < 2.6 \text{ V}$			0.3		μA	
ADC (TEMPERATURE AND CELL MEASUREMENT) CHARACTERISTICS								
$V_{\text{ADC_IN}}$	Input voltage range	$T_A = -40^\circ\text{C}$ to 85°C , $2.4 \text{ V} < V_{\text{CC}} < 2.6 \text{ V}$			-0.2	1		V
$t_{\text{ADC_CONV}}$	Conversion time	$T_A = -40^\circ\text{C}$ to 85°C , $2.4 \text{ V} < V_{\text{CC}} < 2.6 \text{ V}$			125		ms	
	Resolution	$T_A = -40^\circ\text{C}$ to 85°C , $2.4 \text{ V} < V_{\text{CC}} < 2.6 \text{ V}$			14	15		bits
$V_{\text{ADC_OS}}$	Input offset	$T_A = 25^\circ\text{C}$ and $V_{\text{CC}} = 2.5 \text{ V}$			1		mV	
Z_{ADC1}	Effective input resistance (TS) ⁽²⁾	$T_A = -40^\circ\text{C}$ to 85°C , $2.4 \text{ V} < V_{\text{CC}} < 2.6 \text{ V}$			8		M Ω	
Z_{ADC2}	Effective input resistance (BAT) ⁽²⁾	bq27510-G3 not measuring cell voltage	$T_A = -40^\circ\text{C}$ to 85°C , $2.4 \text{ V} < V_{\text{CC}} < 2.6 \text{ V}$		8		M Ω	
		bq27510-G3 measuring cell voltage	$T_A = 25^\circ\text{C}$ and $V_{\text{CC}} = 2.5 \text{ V}$		100		k Ω	
$I_{\text{ADC_LKG}}$	Input leakage current ⁽²⁾	$T_A = -40^\circ\text{C}$ to 85°C , $2.4 \text{ V} < V_{\text{CC}} < 2.6 \text{ V}$			0.3		μA	

(1) LDO output current, I_{OUT} , is the sum of internal and external load currents.

(2) Assured by design. Not production tested.

6.6 Data Flash Memory Characteristics

 $T_A = -40^{\circ}\text{C}$ to 85°C , $2.4\text{ V} < V_{CC} < 2.6\text{ V}$; typical values at $T_A = 25^{\circ}\text{C}$ and $V_{CC} = 2.5\text{ V}$ (unless otherwise noted)

PARAMETER		TEST CONDITIONS	MIN	TYP	MAX	UNIT
t_{DR}	Data retention ⁽¹⁾		10			Years
	Flash programming write-cycles ⁽¹⁾		20,000			Cycles
$t_{WORDPROG}$	Word programming time ⁽¹⁾				2	ms
I_{CCPROG}	Flash-write supply current ⁽¹⁾			5	10	mA

(1) Assured by design. Not production tested.

6.7 400-kHz I²C-Compatible Interface Communication Timing Requirements

 $T_A = -40^{\circ}\text{C}$ to 85°C , $2.4\text{ V} < V_{CC} < 2.6\text{ V}$; typical values at $T_A = 25^{\circ}\text{C}$ and $V_{CC} = 2.5\text{ V}$ (unless otherwise noted)

PARAMETER		TEST CONDITIONS	MIN	TYP	MAX	UNIT
t_r	SCL/SDA rise time				300	ns
t_f	SCL/SDA fall time				300	ns
$t_{w(H)}$	SCL pulse width (high)		600			ns
$t_{w(L)}$	SCL pulse width (low)		1.3			μs
$t_{su(STA)}$	Setup for repeated start		600			ns
$t_{d(STA)}$	Start to first falling edge of SCL		600			ns
$t_{su(DAT)}$	Data setup time		100			ns
$t_{h(DAT)}$	Data hold time		0			ns
$t_{su(STOP)}$	Setup time for stop		600			ns
t_{BUF}	Bus free time between stop and start		66			μs
f_{SCL}	Clock frequency				400	kHz

6.8 100-kHz I²C-Compatible Interface Communication Timing Requirements

 $T_A = -40^{\circ}\text{C}$ to 85°C , $2.4\text{ V} < V_{CC} < 2.6\text{ V}$; typical values at $T_A = 25^{\circ}\text{C}$ and $V_{CC} = 2.5\text{ V}$ (unless otherwise noted)

PARAMETER		TEST CONDITIONS	MIN	TYP	MAX	UNIT
t_r	SCL/SDA rise time				1	μs
t_f	SCL/SDA fall time				300	ns
$t_{w(H)}$	SCL pulse width (high)		4			μs
$t_{w(L)}$	SCL pulse width (low)		4.7			μs
$t_{su(STA)}$	Setup for repeated start		4.7			μs
$t_{d(STA)}$	Start to first falling edge of SCL		4			μs
$t_{su(DAT)}$	Data setup time		250			ns
$t_{h(DAT)}$	Data hold time	Receive mode	0			ns
		Transmit mode	300			
$t_{su(STOP)}$	Setup time for stop		4			μs
t_{BUF}	Bus free time between stop and start		4.7			μs
f_{SCL}	Clock frequency		10		100	kHz
t_{BUSERR}	Bus error timeout		17.3		21.2	s

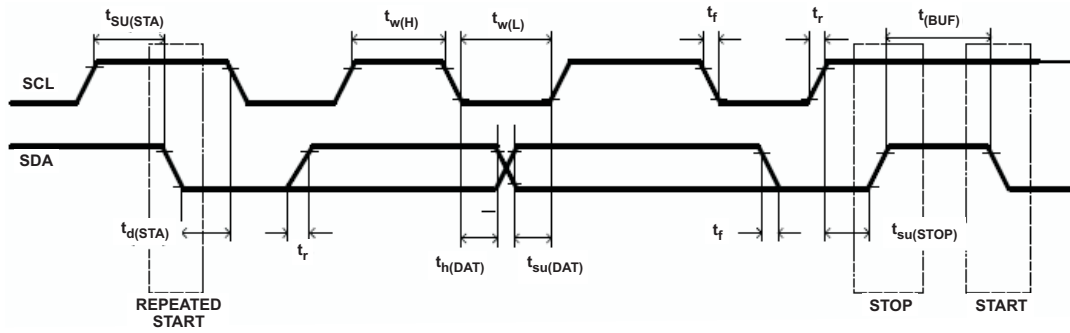
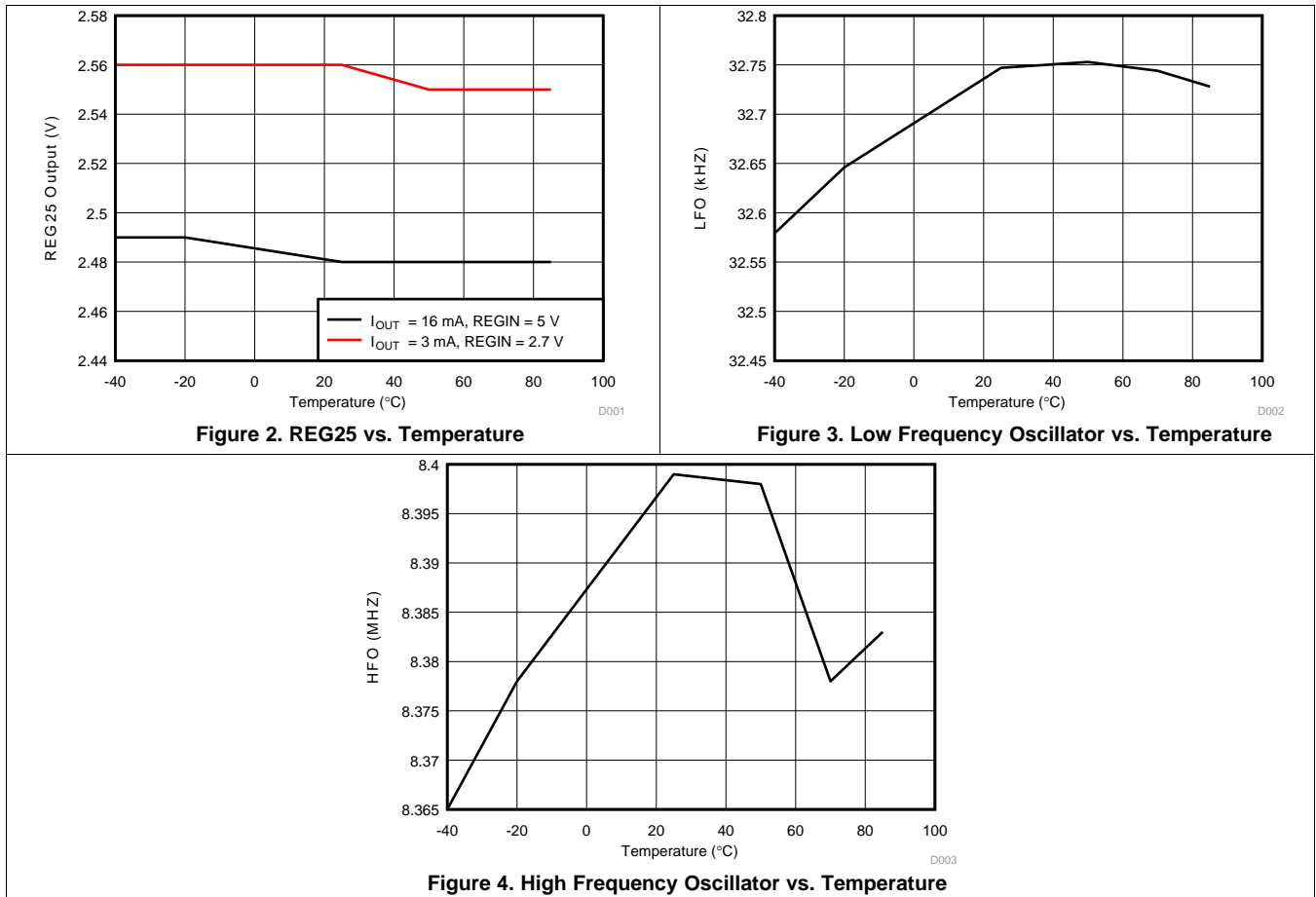

Figure 1. I²C-Compatible Interface Timing Diagram

6.9 Typical Characteristics



7 Detailed Description

7.1 Overview

The bq27510-G3 fuel gauge accurately predicts the battery capacity and other operational characteristics of a single Li-based rechargeable cell. It can be interrogated by a system processor to provide cell information, such as time-to-empty (TTE) and state-of-charge (SOC) as well as SOC interrupt signal to the host.

Information is accessed through a series of commands, called *Standard Commands*. Further capabilities are provided by the additional *Extended Commands* set. Both sets of commands, indicated by the general format *Command()*, read and write information contained within the device control and status registers, as well as its data flash locations. Commands are sent from system to gauge using the I²C serial communications engine, and can be executed during application development, system manufacture, or end-equipment operation.

Cell information is stored in the device in non-volatile flash memory. Many of these data flash locations are accessible during application development. They cannot, generally, be accessed directly during end-equipment operation. Access to these locations is achieved by either use of the fuel gauge companion evaluation software, through individual commands, or through a sequence of data-flash-access commands. To access a desired data flash location, the correct data flash subclass and offset must be known.

The key to the fuel gauge high-accuracy gas gauging prediction is Texas Instruments proprietary Impedance Track™ algorithm. This algorithm uses cell measurements, characteristics, and properties to create state-of-charge predictions that can achieve less than 1% error across a wide variety of operating conditions and over the lifetime of the battery.

The fuel gauge measures charge and discharge activity by monitoring the voltage across a small-value series sense resistor (5 mΩ to 20 mΩ, typical) located between the system V_{SS} and the battery PACK– terminal. When a cell is attached to the device, cell impedance is learned, based on cell current, cell open-circuit voltage (OCV), and cell voltage under loading conditions.

The external temperature sensing is optimized with the use of a high-accuracy negative temperature coefficient (NTC) thermistor with R₂₅ = 10.0 kΩ ± 1%. B_{25/85} = 3435 kΩ ± 1% (such as Semitec NTC 103AT). Alternatively, the fuel gauge can also be configured to use its internal temperature sensor or receive temperature data from the host processor. When an external thermistor is used, a 18.2-kΩ pull-up resistor between BI/TOUT and TS pins is also required. The fuel gauge uses temperature to monitor the battery-pack environment, which is used for fuel gauging and cell protection functionality.

To minimize power consumption, the fuel gauge has several power modes: NORMAL, SLEEP, HIBERNATE, and BAT INSERT CHECK. The fuel gauge passes automatically between these modes, depending upon the occurrence of specific events, though a system processor can initiate some of these modes directly.

For complete operational details, refer to the bq27510-G3 Technical Reference Manual, *bq27510-G3 System-Side Impedance Track™ Fuel Gauge With Integrated LDO*, [SLUUA97](#).

Table 1. Formatting Conventions Used in This Document

INFORMATION TYPE	FORMATTING CONVENTION	EXAMPLE
Commands	<i>Italics</i> with parentheses and no breaking spaces	<i>RemainingCapacity()</i> command
NVM Data	<i>Italics</i> , bold , and breaking spaces	<i>Design Capacity</i> data
Register bits and flags	Brackets and <i>italics</i>	[<i>TDA</i>] bit
NVM Data bits	Brackets, <i>italics</i> , and bold	[<i>LED1</i>] bit
Modes and states	ALL CAPITALS	UNSEALED mode

7.2 Functional Block Diagram

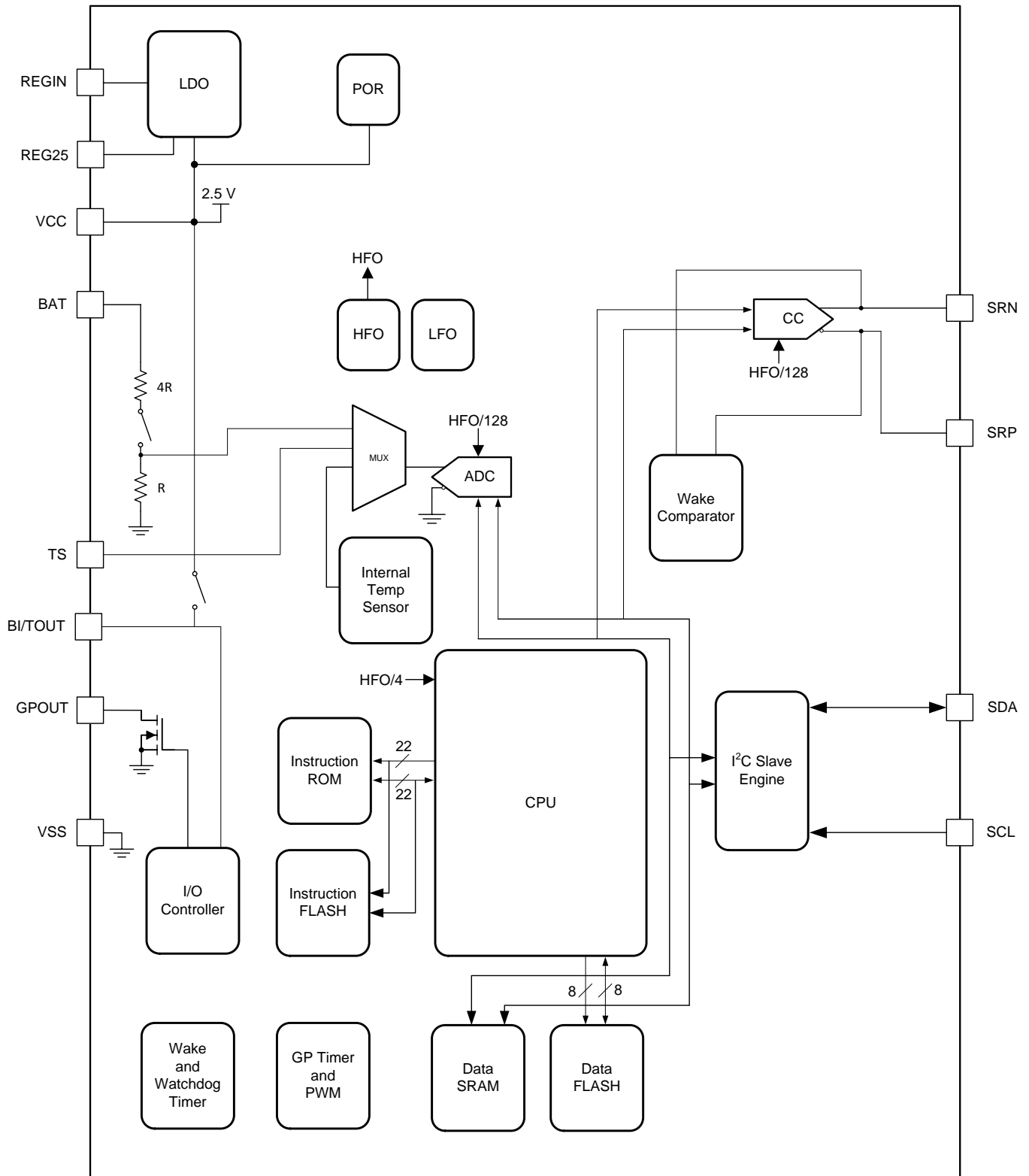

7.3 Feature Description

The fuel gauge measures the cell voltage, temperature, and current to determine battery SOC. The fuel gauge monitors charge and discharge activity by sensing the voltage across a small-value (5 mΩ to 20 mΩ typical) resistor between the SRP and SRN pins and in series with the cell. By integrating charge passing through the battery, the battery's SOC is adjusted during battery charge or discharge.

The total battery capacity is found by comparing states of charge before and after applying the load with the amount of charge passed. When an application load is applied, the impedance of the cell is measured by comparing the OCV obtained from a predefined function for present SOC with the measured voltage under load. Measurements of OCV and charge integration determine chemical state of charge and chemical capacity (Qmax). The initial Qmax values are taken from a cell manufacturers' data sheet multiplied by the number of parallel cells. It is also used for the value in **Design Capacity**. The fuel gauge acquires and updates the battery impedance profile during normal battery usage. It uses this profile, along with SOC and the Qmax value, to determine *FullChargeCapacity()* and *StateOfCharge()*, specifically for the present load and temperature. *FullChargeCapacity()* is reported as capacity available from a fully charged battery under the present load and temperature until *Voltage()* reaches the **Terminate Voltage**. *NominalAvailableCapacity()* and *FullAvailableCapacity()* are the uncompensated (no or light load) versions of *RemainingCapacity()* and *FullChargeCapacity()* respectively.

The fuel gauge has two flags accessed by the *Flags()* function that warns when the battery's SOC has fallen to critical levels. When *StateOfCharge()* falls below the first capacity threshold, specified in **SOC1 Set Threshold**, the *[SOC1]* (*State of Charge Initial*) flag is set. The flag is cleared once *StateOfCharge()* rises above **SOC1 Clear Threshold**. The fuel gauge's GPOUT pin puts out 3 pulses 10ms wide and in 10ms intervals whenever the SOC1 flag is set. This flag is enabled when **RMC_IND** bit in **Operation Configuration B** is set. This behavior also applies to the *[SOCF]* (*State of Charge Final*) flag.

When *Voltage()* falls below the system shut down threshold voltage, **SysDown Set Volt Threshold**, the *[SYSDOWN]* flag is set, serving as a final warning to shut down the system. The GPOUT also signals. When *Voltage()* rises above **SysDown Clear Voltage** and the *[SYSDOWN]* flag has already been set, the *[SYSDOWN]* flag is cleared. The GPOUT also signals such change. All units are in mV. Additional details are found in the bq27510-G3 Technical Reference Manual, *bq27510-G3 System-Side Impedance Track™ Fuel Gauge With Integrated LDO*, [SLUUA97](#).

7.4 Device Functional Modes

7.4.1 Power Modes

The fuel gauge has different power modes: BAT INSERT CHECK, NORMAL, SNOOZE, SLEEP, and HIBERNATE. In NORMAL mode, the fuel gauge is fully powered and can execute any allowable task. In SNOOZE mode, both low-frequency and high-frequency oscillators are active. Although the SNOOZE mode has higher current consumption than the SLEEP mode, it is also a reduced-power mode. In SLEEP mode, the fuel gauge turns off the high-frequency oscillator and exists in a reduced-power state, periodically taking measurements and performing calculations. In HIBERNATE mode, the fuel gauge is in a low-power state, but can be woken up by communication or certain IO activity. Finally, the BAT INSERT CHECK mode is a powered up, but low-power halted, state, where the fuel gauge resides when no battery is inserted into the system.

[Figure 5](#) and [Figure 6](#) show the relationship between these modes.

Device Functional Modes (continued)

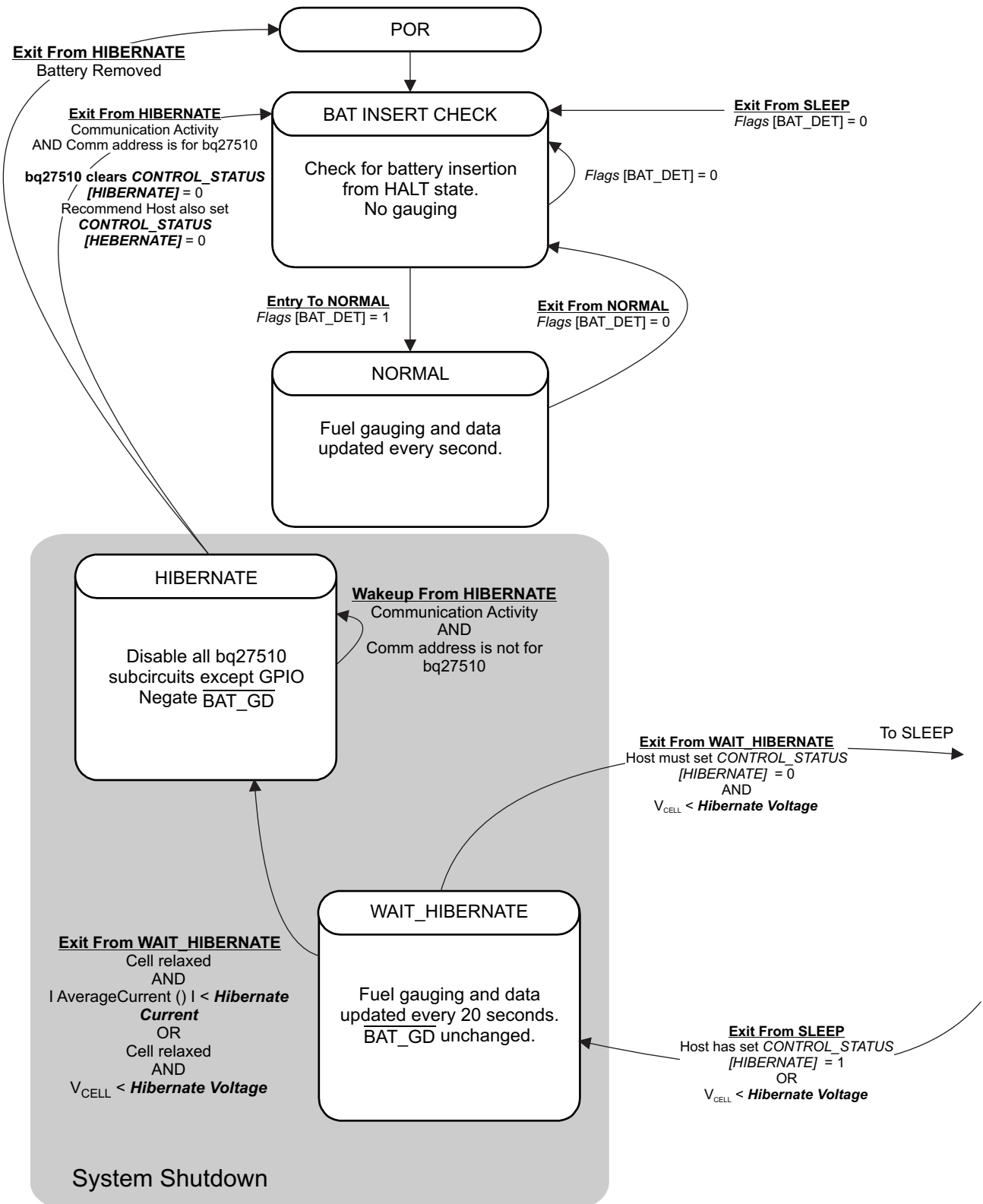

Figure 5. Power Mode Diagram for System Shutdown

Device Functional Modes (continued)

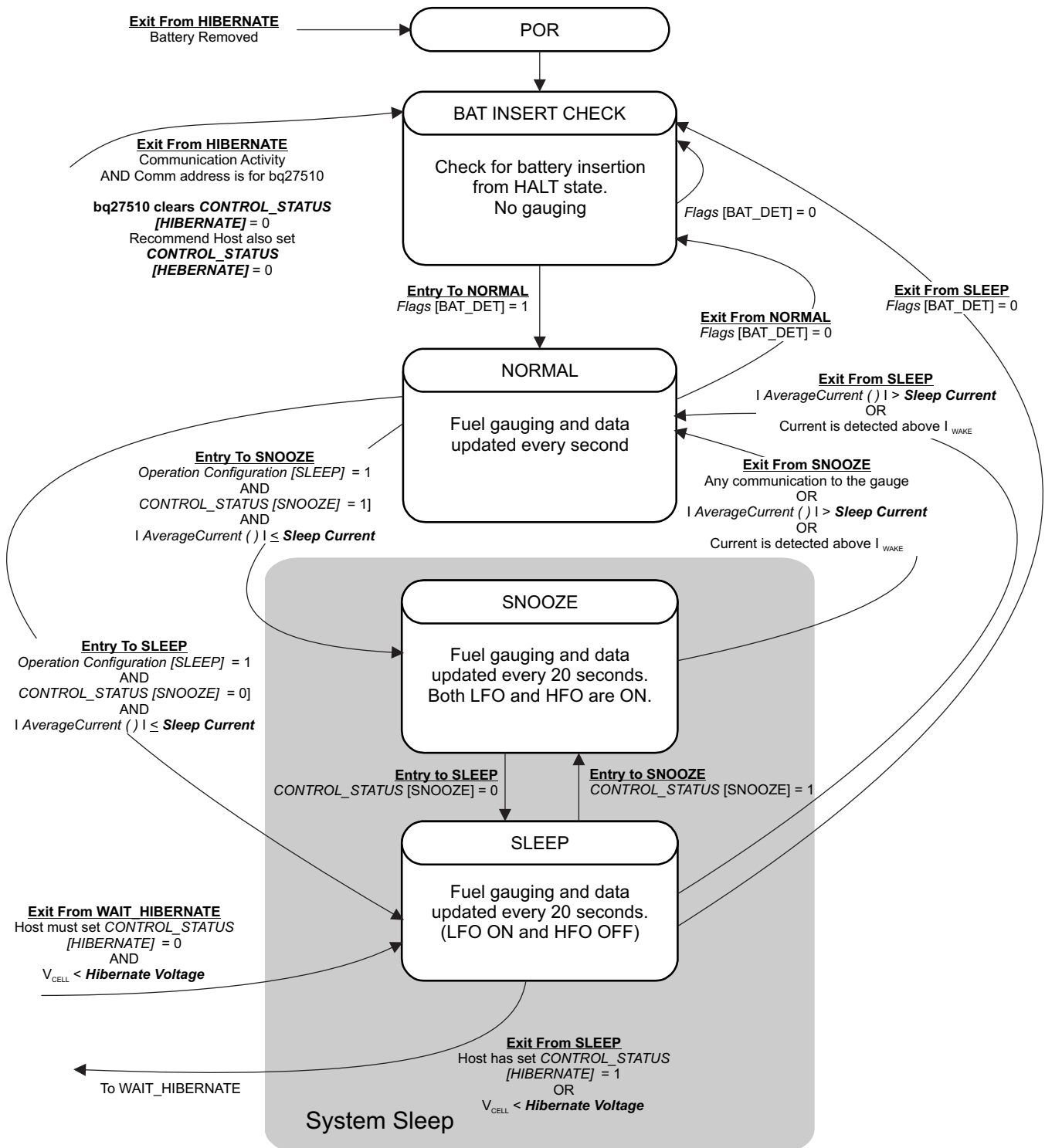

Figure 6. Power Mode Diagram for System Sleep

7.5 Programming

7.5.1 Standard Data Commands

The bq27510-G3 fuel gauge uses a series of 2-byte standard commands to enable system reading and writing of battery information. Each standard command has an associated command-code pair, as indicated in [Table 2](#). Because each command consists of two bytes of data, two consecutive I²C transmissions must be executed both to initiate the command function, and to read or write the corresponding two bytes of data. Additional options for transferring data are described in [Communications](#). Standard commands are accessible in NORMAL operation. Read and write permissions depend on the active access mode, SEALED or UNSEALED. Additional details are found in the *bq27510-G3 Technical Reference Manual*, [SLUUA97](#).

Table 2. Standard Commands

NAME	COMMAND CODE	UNIT	SEALED ACCESS
<i>Control()</i>	0x00 / 0x01	N/A	R/W
<i>AtRate()</i>	0x02 / 0x03	mA	R/W
<i>AtRateTimeToEmpty()</i>	0x04 / 0x05	minutes	R
<i>Temperature()</i>	0x06 / 0x07	0.1 K	R/W
<i>Voltage()</i>	0x08 / 0x09	mV	R
<i>Flags()</i>	0x0a / 0x0b	N/A	R
<i>NominalAvailableCapacity()</i>	0x0c / 0x0d	mAh	R
<i>FullAvailableCapacity()</i>	0x0e / 0x0f	mAh	R
<i>RemainingCapacity()</i>	0x10 / 0x11	mAh	R
<i>FullChargeCapacity()</i>	0x12 / 0x13	mAh	R
<i>AverageCurrent()</i>	0x14 / 0x15	mA	R
<i>TimeToEmpty()</i>	0x16 / 0x17	minutes	R
<i>StandbyCurrent()</i>	0x18 / 0x19	mA	R
<i>StandbyTimeToEmpty()</i>	0x1a / 0x1b	minutes	R
<i>StateOfHealth()</i>	0x1c / 0x1d	% / num	R
<i>CycleCount()</i>	0x1e / 0x1f	num	R
<i>StateOfCharge()</i>	0x20 / 0x21	%	R
<i>InstantaneousCurrent()</i>	0x22 / 0x23	mA	R
<i>InternalTemperature()</i>	0x28 / 0x29	0.1 K	R
<i>ResistanceScale()</i>	0x2a / 0x2b		R
<i>OperationConfiguration()</i>	0x2c / 0x2d	N/A	R
<i>DesignCapacity()</i>	0x2e / 0x2f	mAh	R

7.5.1.1 Control(): 0x00/0x01

Issuing a *Control()* command requires a subsequent 2-byte subcommand. These additional bytes specify the particular control function desired. The *Control()* command allows the system to control specific features of the fuel gauge during normal operation and additional features when the device is in different access modes, as described in [Table 3](#). Additional details are found in the *bq27510-G3 Technical Reference Manual*, [SLUUA97](#).

Table 3. Control() Subcommands

CNTL FUNCTION	CNTL DATA	SEALED ACCESS	DESCRIPTION
CONTROL_STATUS	0x0000	Yes	Reports the status of DF checksum, hibernate, IT, and so forth
DEVICE_TYPE	0x0001	Yes	Reports the device type (for example: 0x0520)
FW_VERSION	0x0002	Yes	Reports the firmware version on the device type
PREV_MACWRITE	0x0007	Yes	Returns previous <i>Control()</i> subcommand code
CHEM_ID	0x0008	Yes	Reports the chemical identifier of the Impedance Track™ configuration
OCV_CMD	0x000C	Yes	Requests the fuel gauge to take an OCV measurement
BAT_INSERT	0x000D	Yes	Forces <i>Flags()</i> [BAT_DET] bit set when OpConfig B [BIE] = 0
BAT_REMOVE	0x000E	Yes	Forces <i>Flags()</i> [BAT_DET] bit clear when OpConfig B [BIE] = 0
SET_HIBERNATE	0x0011	Yes	Forces <i>CONTROL_STATUS [HIBERNATE]</i> to 1
CLEAR_HIBERNATE	0x0012	Yes	Forces <i>CONTROL_STATUS [HIBERNATE]</i> to 0
SET_SLEEP+	0x0013	Yes	Forces <i>CONTROL_STATUS [SNOOZE]</i> to 1
CLEAR_SLEEP+	0x0014	Yes	Forces <i>CONTROL_STATUS [SNOOZE]</i> to 0
DF_VERSION	0x001F	Yes	Returns the Data Flash Version code
SEALED	0x0020	No	Places the fuel gauge in SEALED access mode
IT_ENABLE	0x0021	No	Enables the Impedance Track™ (IT) algorithm
RESET	0x0041	No	Forces a full reset of the fuel gauge

7.5.2 Communications

7.5.2.1 I²C Interface

The bq27510-G3 fuel gauge supports the standard I²C read, incremental read, quick read, one byte write, and incremental write functions. The 7-bit device address (ADDR) is the most significant 7 bits of the hex address and is fixed as 1010101. The first 8-bits of the I²C protocol is, therefore, 0xAA or 0xAB for write or read, respectively.

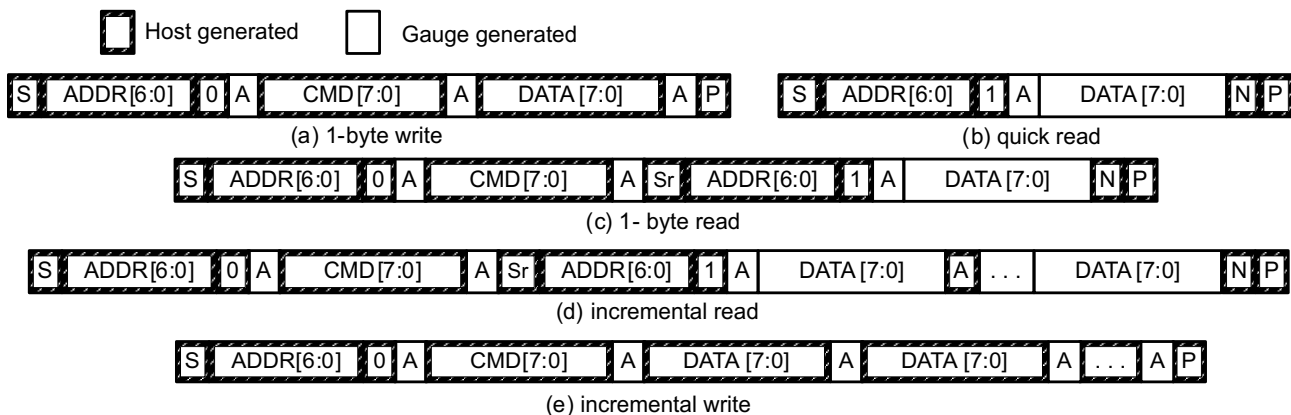

(S = Start, Sr = Repeated Start, A = Acknowledge, N = No Acknowledge, and P = Stop).

Figure 7. I²C Read, Incremental Read, Quick Read, One Byte Write, and Incremental Write Functions

The “quick read” returns data at the address indicated by the address pointer. The address pointer, a register internal to the I²C communication engine, increments whenever data is acknowledged by the fuel gauge or the I²C master. “Quick writes” function in the same manner and are a convenient means of sending multiple bytes to consecutive command locations (such as two-byte commands that require two bytes of data)

The following command sequences are not supported:

Attempt to write a read-only address (NACK after data sent by master):

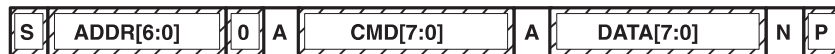

Figure 8. Invalid Write

Attempt to read an address above 0x6B (NACK command):



Figure 9. Invalid Read

7.5.2.2 I²C Time Out

The I²C engine releases both SDA and SCL if the I²C bus is held low for 2 seconds. If the fuel gauge was holding the lines, releasing them frees them for the master to drive the lines. If an external condition is holding either of the lines low, the I²C engine enters the low-power sleep mode.

7.5.2.3 I²C Command Waiting Time

To ensure proper operation at 400 kHz, a $t_{(BUF)} \geq 66 \mu s$ bus free waiting time must be inserted between all packets addressed to the fuel gauge. In addition, if the SCL clock frequency (f_{SCL}) is > 100 kHz, use individual 1-byte write commands for proper data flow control. The following diagram shows the standard waiting time required between issuing the control subcommand the reading the status result. For read-write standard command, a minimum of 2 seconds is required to get the result updated. For read-only standard commands, there is no waiting time required, but the host should not issue all standard commands more than two times per second. Otherwise, the fuel gauge could result in a reset issue due to the expiration of the watchdog timer.

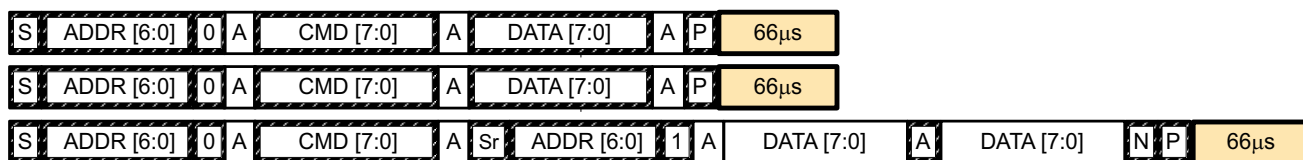

Waiting time inserted between two 1-byte write packets for a subcommand and reading results (required for $100 \text{ kHz} < f_{SCL} \leq 400 \text{ kHz}$)

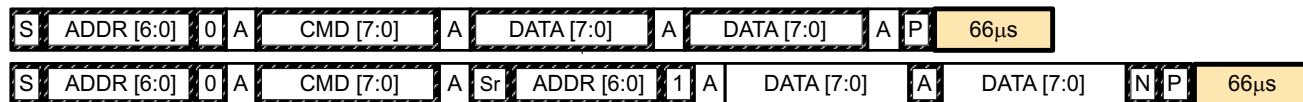

Waiting time inserted between incremental 2-byte write packet for a subcommand and reading results (acceptable for $f_{SCL} \leq 100 \text{ kHz}$)

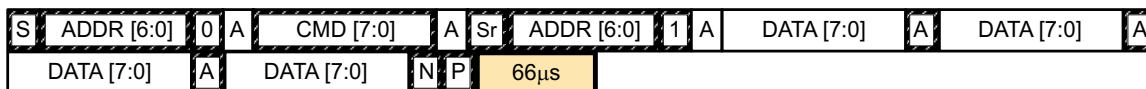

Waiting time inserted after incremental read

Figure 10. Standard I²C Command Waiting Time Required

7.5.2.4 I²C Clock Stretching

A clock stretch can occur during all modes of fuel gauge operation. In SLEEP and HIBERNATE modes, a short clock stretch occurs on all I²C traffic as the device must wake-up to process the packet. In the other modes (BAT INSERT CHECK, NORMAL) clock stretching only occurs for packets addressed for the fuel gauge. The majority of clock stretch periods are small as the I²C interface performs normal data flow control. However, less frequent yet more significant clock stretch periods may occur as blocks of Data Flash are updated. The following table summarizes the approximate clock stretch duration for various fuel gauge operating conditions.

Table 4. Approximate Clock Stretch Duration

GAUGING MODE	OPERATING CONDITION OR COMMENT	APPROXIMATE DURATION
SLEEP HIBERNATE	Clock stretch occurs at the beginning of all traffic as the device wakes up.	≤ 4 ms
BAT INSERT CHECK, NORMAL	Clock stretch occurs within the packet for flow control (after a start bit, ACK or first data bit).	≤ 4 ms
	Normal Ra table Data Flash updates.	24 ms
	Data Flash block writes.	72 ms
	Restored Data Flash block write after loss of power.	116 ms
	End of discharge Ra table Data Flash update.	144 ms

8 Application and Implementation

NOTE

Information in the following applications sections is not part of the TI component specification, and TI does not warrant its accuracy or completeness. TI's customers are responsible for determining suitability of components for their purposes. Customers should validate and test their design implementation to confirm system functionality.

8.1 Application Information

The bq27510-G3 system-side Li-Ion battery fuel gauge is a microcontroller peripheral that provides fuel gauging for single-cell Li-Ion battery packs. The device requires little system microcontroller firmware development. The fuel resides on the main board of the system and manages an embedded battery (non-removable) or a up to 32000-mAhr Capacity removable battery pack. To allow for optimal performance in the end application, special considerations must be taken to ensure minimization of measurement error through proper printed circuit board (PCB) board layout. Such requirements are detailed in [Design Requirements](#).

8.2 Typical Application

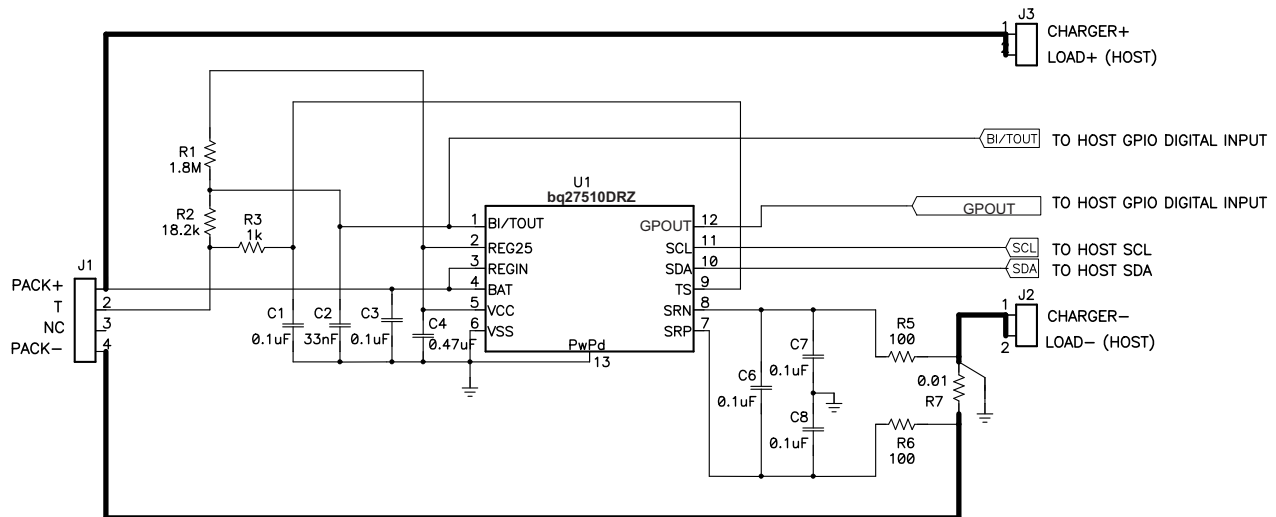

Figure 11. bq27510-G3 Typical Application

8.2.1 Design Requirements

Several key parameters must be updated to align with a given application's battery characteristics. For highest accuracy gauging, it is important to follow-up this initial configuration with a learning cycle to optimize resistance and maximum chemical capacity (Q_{max}) values prior to sealing and shipping systems to the field. Successful and accurate configuration of the fuel gauge for a target application can be used as the basis for creating a "golden" gas gauge (.fs) file that can be written to all gauges, assuming identical pack design and Li-ion cell origin (chemistry, lot, and so on). Calibration data is included as part of this golden GG file to cut down on system production time. If going this route, it is recommended to average the voltage and current measurement calibration data from a large sample size and use these in the golden file. [Table 5, Key Data Flash Parameters for Configuration](#), shows the items that should be configured to achieve reliable protection and accurate gauging with minimal initial configuration.

Typical Application (continued)
Table 5. Key Data Flash Parameters for Configuration

NAME	DEFAULT	UNIT	RECOMMENDED SETTING
Design Capacity	1000	mAh	Set based on the nominal pack capacity as interpreted from cell manufacturer's datasheet. If multiple parallel cells are used, should be set to N × Cell Capacity.
Design Energy Scale	1	-	Set to 10 to convert all power values to cWh or to 1 for mWh. Design Energy is divided by this value.
Reserve Capacity-mAh	0	mAh	Set to desired runtime remaining (in seconds / 3600) × typical applied load between reporting 0% SOC and reaching Terminate Voltage , if needed.
Chem ID	0100	hex	Should be configured using TI-supplied Battery Management Studio software. Default open-circuit voltage and resistance tables are also updated in conjunction with this step. Do not attempt to manually update reported Device Chemistry as this does not change all chemistry information! Always update chemistry using the appropriate software tool (that is, bqStudio).
Load Mode	1	-	Set to applicable load model, 0 for constant current or 1 for constant power.
Load Select	1	-	Set to load profile which most closely matches typical system load.
Qmax Cell 0	1000	mAh	Set to initial configured value for Design Capacity. The gauge will update this parameter automatically after the optimization cycle and for every regular Qmax update thereafter.
Cell0 V at Chg Term	4200	mV	Set to nominal cell voltage for a fully charged cell. The gauge will update this parameter automatically each time full charge termination is detected.
Terminate Voltage	3200	mV	Set to empty point reference of battery based on system needs. Typical is between 3000 and 3200 mV.
Ra Max Delta	44	mΩ	Set to 15% of Cell0 R_a 4 resistance after an optimization cycle is completed.
Charging Voltage	4200	mV	Set based on nominal charge voltage for the battery in normal conditions (25°C, etc). Used as the reference point for offsetting by Taper Voltage for full charge termination detection.
Taper Current	100	mA	Set to the nominal taper current of the charger + taper current tolerance to ensure that the gauge will reliably detect charge termination.
Taper Voltage	100	mV	Sets the voltage window for qualifying full charge termination. Can be set tighter to avoid or wider to ensure possibility of reporting 100% SOC in outer JEITA temperature ranges that use derated charging voltage.
Dsg Current Threshold	60	mA	Sets threshold for gauge detecting battery discharge. Should be set lower than minimal system load expected in the application and higher than Quit Current .
Chg Current Threshold	75	mA	Sets the threshold for detecting battery charge. Can be set higher or lower depending on typical trickle charge current used. Also should be set higher than Quit Current .
Quit Current	40	mA	Sets threshold for gauge detecting battery relaxation. Can be set higher or lower depending on typical standby current and exhibited in the end system.
Avg I Last Run	-299	mA	Current profile used in capacity simulations at onset of discharge or at all times if Load Select = 0. Should be set to nominal system load. Is automatically updated by the gauge every cycle.
Avg P Last Run	-1131	mW	Power profile used in capacity simulations at onset of discharge or at all times if Load Select = 0. Should be set to nominal system power. Is automatically updated by the gauge every cycle.
Sleep Current	10	mA	Sets the threshold at which the fuel gauge enters SLEEP mode. Take care in setting above typical standby currents else entry to SLEEP may be unintentionally blocked.
CC Gain	10	mohms	Calibrate this parameter using TI-supplied bqStudio software and calibration procedure in the TRM. Determines conversion of coulomb counter measured sense resistor voltage to current.
CC Delta	10	mohms	Calibrate this parameter using TI-supplied bqStudio software and calibration procedure in the TRM. Determines conversion of coulomb counter measured sense resistor voltage to passed charge.
Board Offset	0	Counts	Calibrate this parameter using TI-supplied bqStudio software and calibration procedure in the TRM. Determines native offset of the printed circuit board parasitics that should be removed from conversions.

Typical Application (continued)

Table 5. Key Data Flash Parameters for Configuration (continued)

NAME	DEFAULT	UNIT	RECOMMENDED SETTING
Pack V Offset	0	mV	Calibrate this parameter using TI-supplied bqStudio software and calibration procedure in the TRM. Determines voltage offset between cell tab and ADC input node to incorporate back into or remove from measurement, depending on polarity.

8.2.2 Detailed Design Procedure

8.2.2.1 BAT Voltage Sense Input

A ceramic capacitor at the input to the BAT pin is used to bypass AC voltage ripple to ground, greatly reducing its influence on battery voltage measurements. It proves most effective in applications with load profiles that exhibit high-frequency current pulses (that is, cell phones) but is recommended for use in all applications to reduce noise on this sensitive high-impedance measurement node.

8.2.2.2 SRP and SRN Current Sense Inputs

The filter network at the input to the coulomb counter is intended to improve differential mode rejection of voltage measured across the sense resistor. These components should be placed as close as possible to the coulomb counter inputs and the routing of the differential traces length-matched to best minimize impedance mismatch-induced measurement errors.

8.2.2.3 Sense Resistor Selection

Any variation encountered in the resistance present between the SRP and SRN pins of the fuel gauge will affect the resulting differential voltage, and derived current, it senses. As such, it is recommended to select a sense resistor with minimal tolerance and temperature coefficient of resistance (TCR) characteristics. The standard recommendation based on best compromise between performance and price is a 1% tolerance, 100 ppm drift sense resistor with a 1-W power rating.

8.2.2.4 TS Temperature Sense Input

Similar to the BAT pin, a ceramic decoupling capacitor for the TS pin is used to bypass AC voltage ripple away from the high-impedance ADC input, minimizing measurement error. Another helpful advantage is that the capacitor provides additional ESD protection since the TS input to system may be accessible in systems that use removable battery packs. It should be placed as close as possible to the respective input pin for optimal filtering performance.

8.2.2.5 Thermistor Selection

The fuel gauge temperature sensing circuitry is designed to work with a negative temperature coefficient-type (NTC) thermistor with a characteristic 10-kΩ resistance at room temperature (25°C). The default curve-fitting coefficients configured in the fuel gauge specifically assume a 103AT-2 type thermistor profile and so that is the default recommendation for thermistor selection purposes. Moving to a separate thermistor resistance profile (for example, JT-2 or others) requires an update to the default thermistor coefficients in data flash to ensure highest accuracy temperature measurement performance.

8.2.2.6 REGIN Power Supply Input Filtering

A ceramic capacitor is placed at the input to the fuel gauge internal LDO to increase power supply rejection (PSR) and improve effective line regulation. It ensures that voltage ripple is rejected to ground instead of coupling into the internal supply rails of the fuel gauge.

8.2.2.7 V_{CC} LDO Output Filtering

A ceramic capacitor is also needed at the output of the internal LDO to provide a current reservoir for fuel gauge load peaks during high peripheral utilization. It acts to stabilize the regulator output and reduce core voltage ripple inside of the fuel gauge.

8.2.3 Application Curves

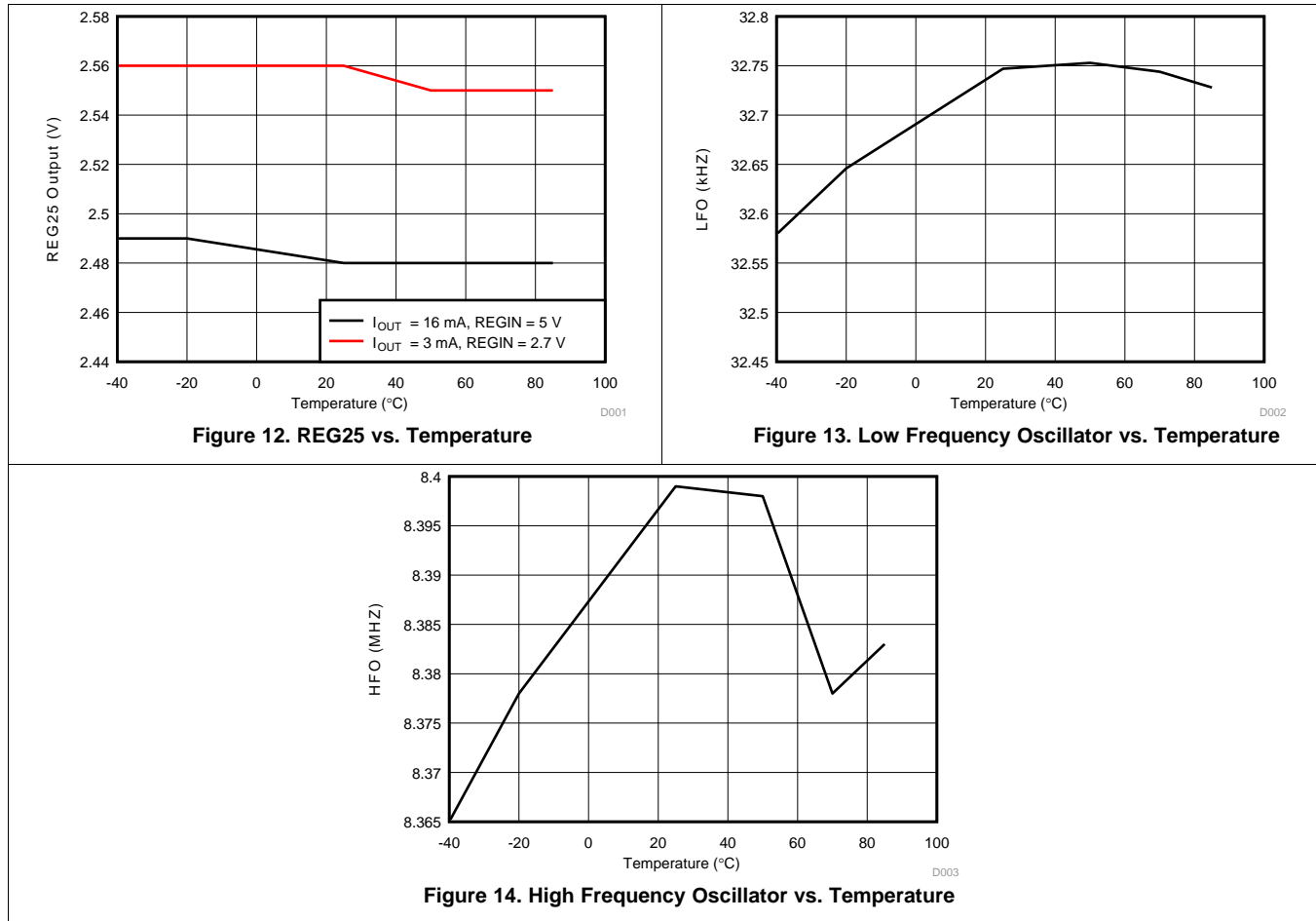

9 Power Supply Recommendations

9.1 Power Supply Decoupling

Both the REGIN input pin and the V_{CC} output pin require low equivalent series resistance (ESR) ceramic capacitors placed as closely as possible to the respective pins to optimize ripple rejection and provide a stable and dependable power rail that is resilient to line transients. A 0.1-μF capacitor at the REGIN and a 1-μF capacitor at V_{CC} will suffice for satisfactory device performance.

10 Layout

10.1 Layout Guidelines

10.1.1 Sense Resistor Connections

Kelvin connections at the sense resistor are just as critical as those for the battery terminals themselves. The differential traces should be connected at the inside of the sense resistor pads and not anywhere along the high-current trace path to prevent false increases to measured current that could result when measuring between the sum of the sense resistor and trace resistance between the tap points. In addition, the routing of these leads from the sense resistor to the input filter network and finally into the SRP and SRN pins needs to be as closely matched in length as possible else additional measurement offset could occur. It is further recommended to add copper trace or pour-based "guard rings" around the perimeter of the filter network and coulomb counter inputs to shield these sensitive pins from radiated EMI into the sense nodes. This prevents differential voltage shifts that could be interpreted as real current change to the fuel gauge. All of the filter components need to be placed as close as possible to the coulomb counter input pins.

10.1.2 Thermistor Connections

The thermistor sense input should include a ceramic bypass capacitor placed as close to the TS input pin as possible. The capacitor helps to filter measurements of any stray transients as the voltage bias circuit pulses periodically during temperature sensing windows.

10.1.3 High-Current and Low-Current Path Separation

For best possible noise performance, it is extremely important to separate the low-current and high-current loops to different areas of the board layout. The fuel gauge and all support components should be situated on one side of the boards and tap off of the high-current loop (for measurement purposes) at the sense resistor. Routing the low-current ground around instead of under high-current traces will further help to improve noise rejection.

10.2 Layout Example

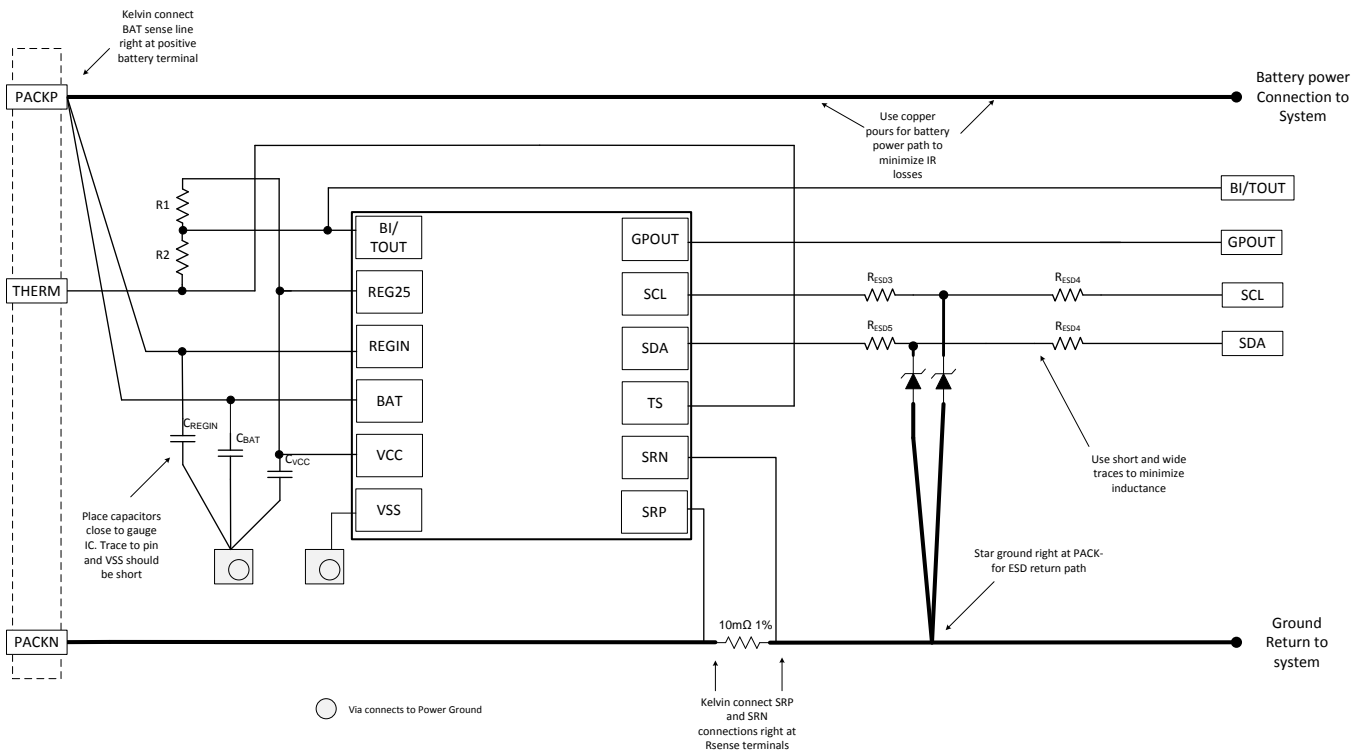

Figure 15. bq27510-G3 Board Layout

11 Device and Documentation Support

11.1 Device Support

11.1.1 Third-Party Products Disclaimer

TI'S PUBLICATION OF INFORMATION REGARDING THIRD-PARTY PRODUCTS OR SERVICES DOES NOT CONSTITUTE AN ENDORSEMENT REGARDING THE SUITABILITY OF SUCH PRODUCTS OR SERVICES OR A WARRANTY, REPRESENTATION OR ENDORSEMENT OF SUCH PRODUCTS OR SERVICES, EITHER ALONE OR IN COMBINATION WITH ANY TI PRODUCT OR SERVICE.

11.2 Documentation Support

11.2.1 Related Documentation

For related documentation see the following:

- bq27510-G3 Technical Reference Manual, *bq27510-G3 System-Side Impedance Track™ Fuel Gauge With Integrated LDO*, [SLUUA97](#)

11.3 Community Resources

The following links connect to TI community resources. Linked contents are provided "AS IS" by the respective contributors. They do not constitute TI specifications and do not necessarily reflect TI's views; see TI's [Terms of Use](#).

TI E2E™ Online Community *TI's Engineer-to-Engineer (E2E) Community*. Created to foster collaboration among engineers. At e2e.ti.com, you can ask questions, share knowledge, explore ideas and help solve problems with fellow engineers.

Design Support *TI's Design Support* Quickly find helpful E2E forums along with design support tools and contact information for technical support.

11.4 Trademarks

Impedance Track, E2E are trademarks of Texas Instruments.
All other trademarks are the property of their respective owners.

11.5 Electrostatic Discharge Caution



These devices have limited built-in ESD protection. The leads should be shorted together or the device placed in conductive foam during storage or handling to prevent electrostatic damage to the MOS gates.

11.6 Glossary

[SLYZ022](#) — *TI Glossary*.

This glossary lists and explains terms, acronyms, and definitions.

12 Mechanical, Packaging, and Orderable Information

The following pages include mechanical, packaging, and orderable information. This information is the most current data available for the designated devices. This data is subject to change without notice and revision of this document. For browser-based versions of this data sheet, refer to the left-hand navigation.

PACKAGING INFORMATION

Orderable Device	Status (1)	Package Type	Package Drawing	Pins	Package Qty	Eco Plan (2)	Lead/Ball Finish (6)	MSL Peak Temp (3)	Op Temp (°C)	Device Marking (4/5)	Samples
BQ27510DRZR-G3	ACTIVE	SON	DRZ	12	3000	Green (RoHS & no Sb/Br)	CU NIPDAU	Level-2-260C-1 YEAR	-40 to 85	BQ 7510	Samples
BQ27510DRZT-G3	ACTIVE	SON	DRZ	12	250	Green (RoHS & no Sb/Br)	CU NIPDAU	Level-2-260C-1 YEAR	-40 to 85	BQ 7510	Samples

(1) The marketing status values are defined as follows:

ACTIVE: Product device recommended for new designs.

LIFEBUY: TI has announced that the device will be discontinued, and a lifetime-buy period is in effect.

NRND: Not recommended for new designs. Device is in production to support existing customers, but TI does not recommend using this part in a new design.

PREVIEW: Device has been announced but is not in production. Samples may or may not be available.

OBSELETE: TI has discontinued the production of the device.

(2) Eco Plan - The planned eco-friendly classification: Pb-Free (RoHS), Pb-Free (RoHS Exempt), or Green (RoHS & no Sb/Br) - please check <http://www.ti.com/productcontent> for the latest availability information and additional product content details.

TBD: The Pb-Free/Green conversion plan has not been defined.

Pb-Free (RoHS): TI's terms "Lead-Free" or "Pb-Free" mean semiconductor products that are compatible with the current RoHS requirements for all 6 substances, including the requirement that lead not exceed 0.1% by weight in homogeneous materials. Where designed to be soldered at high temperatures, TI Pb-Free products are suitable for use in specified lead-free processes.

Pb-Free (RoHS Exempt): This component has a RoHS exemption for either 1) lead-based flip-chip solder bumps used between the die and package, or 2) lead-based die adhesive used between the die and leadframe. The component is otherwise considered Pb-Free (RoHS compatible) as defined above.

Green (RoHS & no Sb/Br): TI defines "Green" to mean Pb-Free (RoHS compatible), and free of Bromine (Br) and Antimony (Sb) based flame retardants (Br or Sb do not exceed 0.1% by weight in homogeneous material)

(3) MSL, Peak Temp. - The Moisture Sensitivity Level rating according to the JEDEC industry standard classifications, and peak solder temperature.

(4) There may be additional marking, which relates to the logo, the lot trace code information, or the environmental category on the device.

(5) Multiple Device Markings will be inside parentheses. Only one Device Marking contained in parentheses and separated by a "~" will appear on a device. If a line is indented then it is a continuation of the previous line and the two combined represent the entire Device Marking for that device.

(6) Lead/Ball Finish - Orderable Devices may have multiple material finish options. Finish options are separated by a vertical ruled line. Lead/Ball Finish values may wrap to two lines if the finish value exceeds the maximum column width.

Important Information and Disclaimer: The information provided on this page represents TI's knowledge and belief as of the date that it is provided. TI bases its knowledge and belief on information provided by third parties, and makes no representation or warranty as to the accuracy of such information. Efforts are underway to better integrate information from third parties. TI has taken and continues to take reasonable steps to provide representative and accurate information but may not have conducted destructive testing or chemical analysis on incoming materials and chemicals. TI and TI suppliers consider certain information to be proprietary, and thus CAS numbers and other limited information may not be available for release.

In no event shall TI's liability arising out of such information exceed the total purchase price of the TI part(s) at issue in this document sold by TI to Customer on an annual basis.

TAPE AND REEL INFORMATION



QUADRANT ASSIGNMENTS FOR PIN 1 ORIENTATION IN TAPE



*All dimensions are nominal

Device	Package Type	Package Drawing	Pins	SPQ	Reel Diameter (mm)	Reel Width W1 (mm)	A0 (mm)	B0 (mm)	K0 (mm)	P1 (mm)	W (mm)	Pin1 Quadrant
BQ27510DRZR-G3	SON	DRZ	12	3000	330.0	12.4	2.8	4.3	1.2	4.0	12.0	Q2
BQ27510DRZT-G3	SON	DRZ	12	250	180.0	12.4	2.8	4.3	1.2	4.0	12.0	Q2

TAPE AND REEL BOX DIMENSIONS





*All dimensions are nominal

Device	Package Type	Package Drawing	Pins	SPQ	Length (mm)	Width (mm)	Height (mm)
BQ27510DRZR-G3	SON	DRZ	12	3000	367.0	367.0	35.0
BQ27510DRZT-G3	SON	DRZ	12	250	210.0	185.0	35.0

DRZ (S-PDSO-N12)

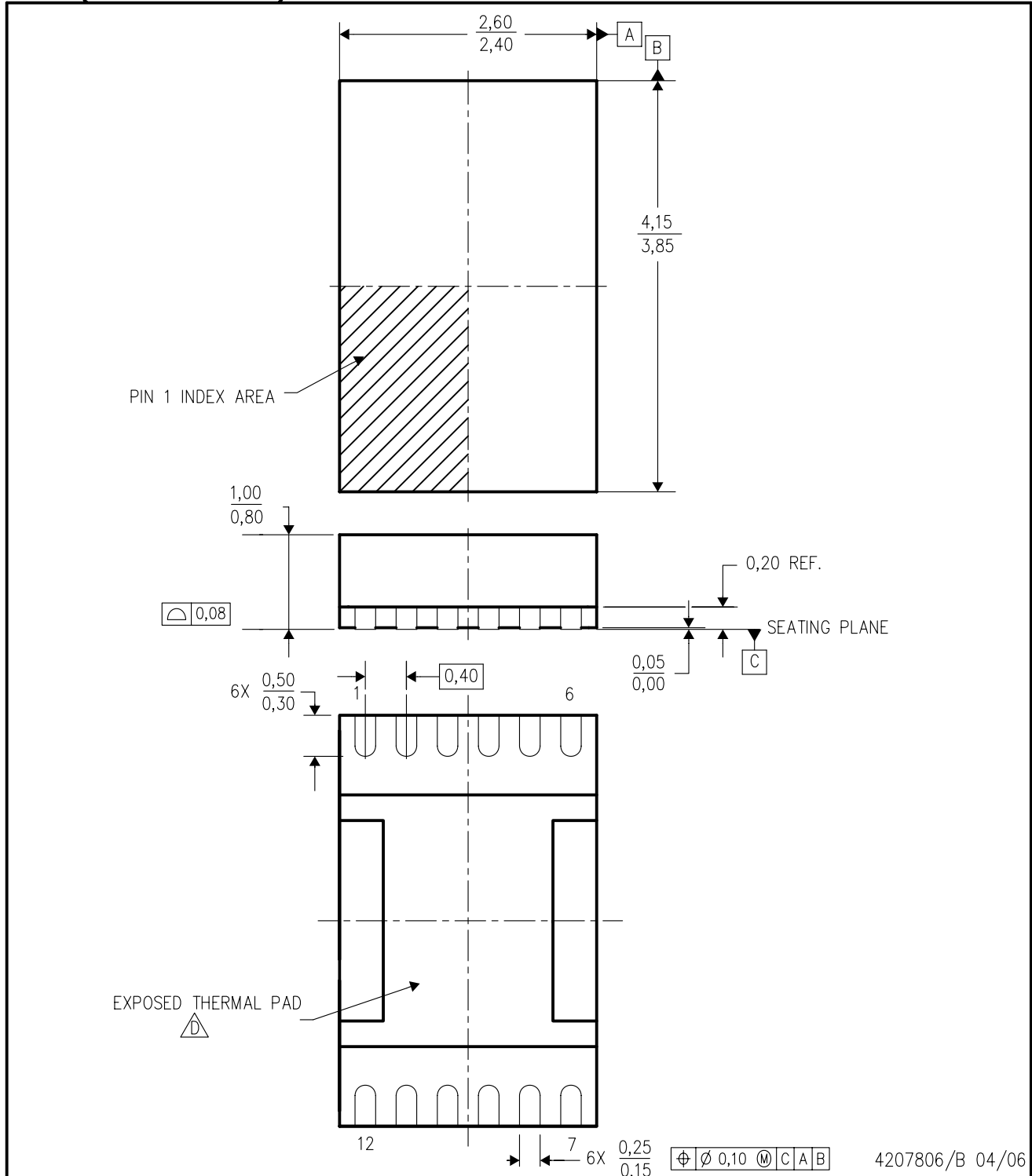
PLASTIC SMALL OUTLINE



- NOTES:
- A. All linear dimensions are in millimeters. Dimensioning and tolerancing per ASME Y14.5M-1994.
 - B. This drawing is subject to change without notice.
 - C. Small Outline No-Lead (SON) package configuration.
 -  The package thermal pad must be soldered to the board for thermal and mechanical performance. See the Product Data Sheet for details regarding the exposed thermal pad dimensions.
 - E. This package is lead-free.

DRZ (R-PDSO-N12)

PLASTIC SMALL OUTLINE NO-LEAD

THERMAL INFORMATION

This package incorporates an exposed thermal pad that is designed to be attached directly to an external heatsink. The thermal pad must be soldered directly to the printed circuit board (PCB). After soldering, the PCB can be used as a heatsink. In addition, through the use of thermal vias, the thermal pad can be attached directly to the appropriate copper plane shown in the electrical schematic for the device, or alternatively, can be attached to a special heatsink structure designed into the PCB. This design optimizes the heat transfer from the integrated circuit (IC).

For information on the Quad Flatpack No-Lead (QFN) package and its advantages, refer to Application Report, QFN/SON PCB Attachment, Texas Instruments Literature No. SLUA271. This document is available at www.ti.com.

The exposed thermal pad dimensions for this package are shown in the following illustration.

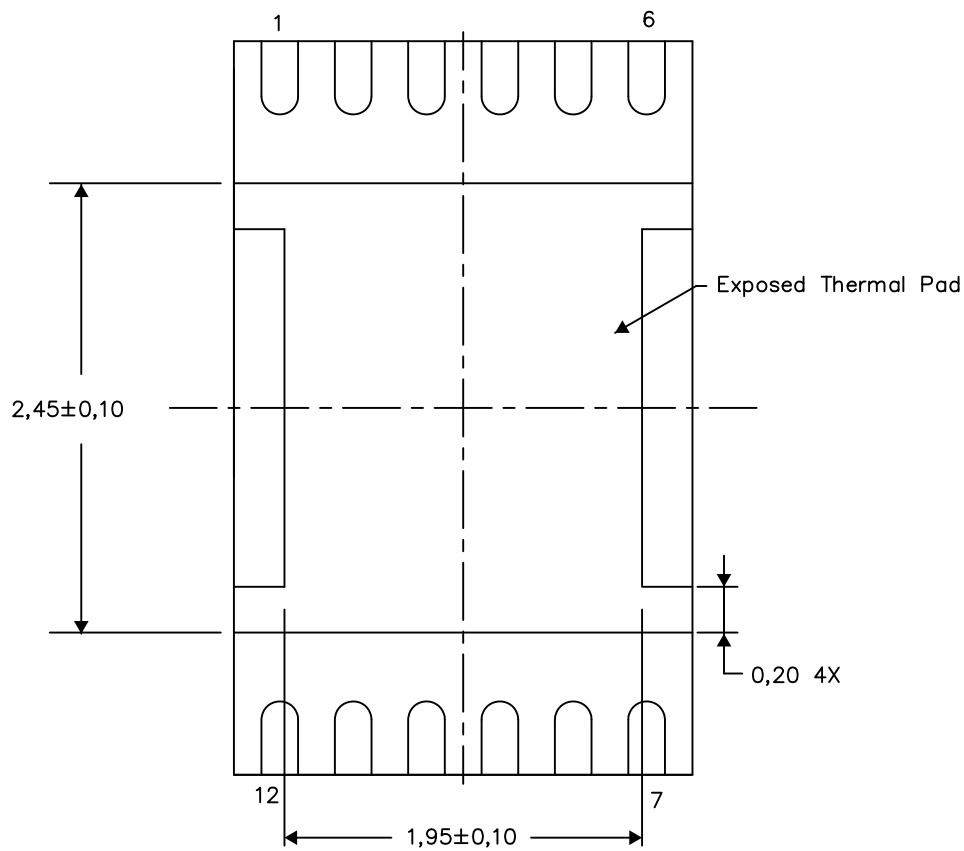

Bottom View
Exposed Thermal Pad Dimensions

4208114/F 10/14

NOTE: All linear dimensions are in millimeters

DRZ (S-PDSO-N12)

PLASTIC SMALL OUTLINE NO-LEAD

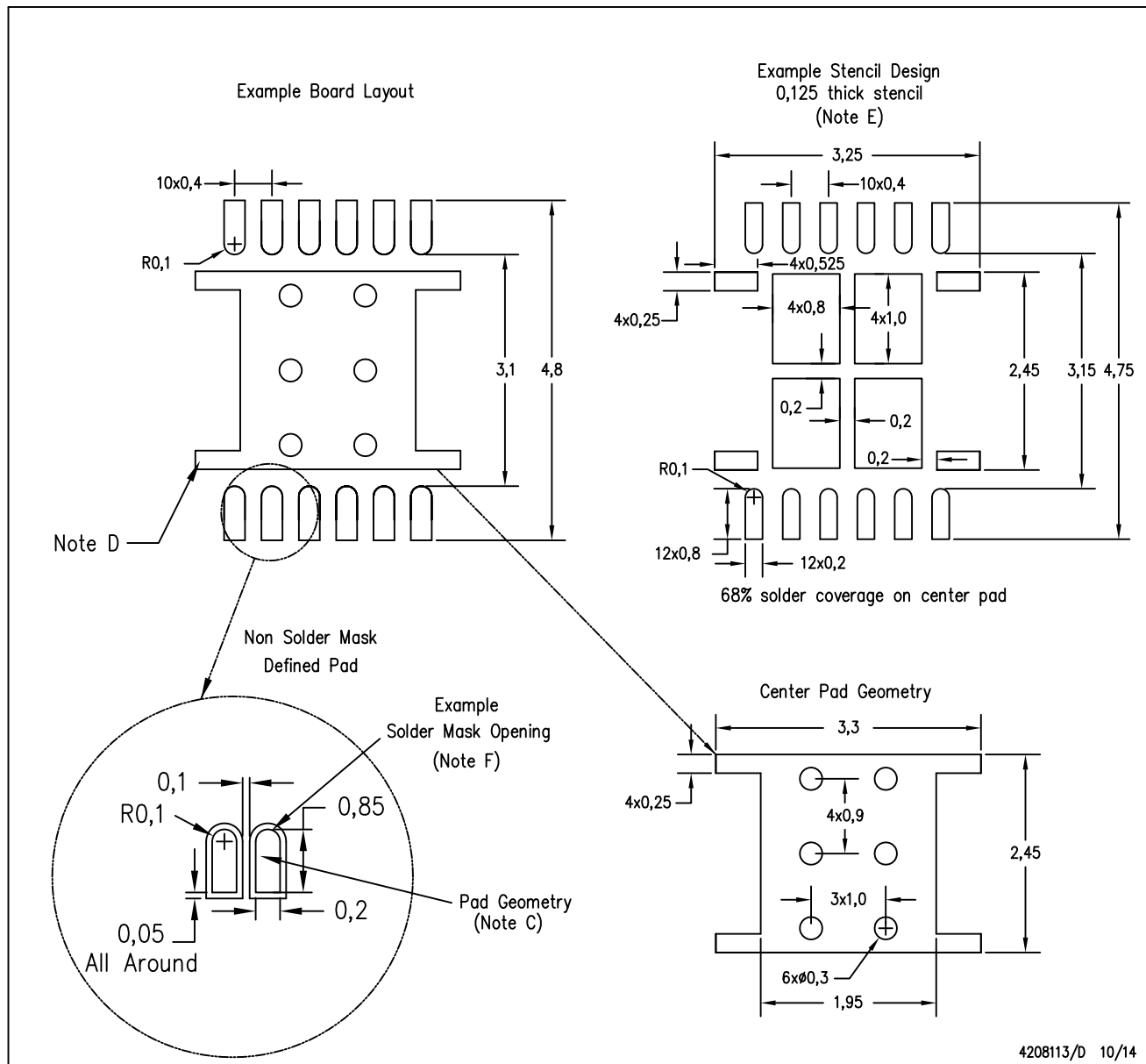

4208113/D 10/14

- NOTES:
- All linear dimensions are in millimeters.
 - This drawing is subject to change without notice.
 - Publication IPC-7351 is recommended for alternate designs.
 - This package is designed to be soldered to a thermal pad on the board. Refer to Application Note, Quad Flat-Pack Packages, Texas Instruments Literature No. SCBA017, SLUA271, and also the Product Data Sheets for specific thermal information, via requirements, and recommended board layout. These documents are available at www.ti.com <<http://www.ti.com>>.
 - Laser cutting apertures with trapezoidal walls and also rounding corners will offer better paste release. Customers should contact their board assembly site for stencil design recommendations. Refer to IPC 7525 for stencil design considerations.
 - Customers should contact their board fabrication site for minimum solder mask web tolerances between signal pads.

IMPORTANT NOTICE

Texas Instruments Incorporated (TI) reserves the right to make corrections, enhancements, improvements and other changes to its semiconductor products and services per JESD46, latest issue, and to discontinue any product or service per JESD48, latest issue. Buyers should obtain the latest relevant information before placing orders and should verify that such information is current and complete.

TI's published terms of sale for semiconductor products (<http://www.ti.com/sc/docs/stdterms.htm>) apply to the sale of packaged integrated circuit products that TI has qualified and released to market. Additional terms may apply to the use or sale of other types of TI products and services.

Reproduction of significant portions of TI information in TI data sheets is permissible only if reproduction is without alteration and is accompanied by all associated warranties, conditions, limitations, and notices. TI is not responsible or liable for such reproduced documentation. Information of third parties may be subject to additional restrictions. Resale of TI products or services with statements different from or beyond the parameters stated by TI for that product or service voids all express and any implied warranties for the associated TI product or service and is an unfair and deceptive business practice. TI is not responsible or liable for any such statements.

Buyers and others who are developing systems that incorporate TI products (collectively, "Designers") understand and agree that Designers remain responsible for using their independent analysis, evaluation and judgment in designing their applications and that Designers have full and exclusive responsibility to assure the safety of Designers' applications and compliance of their applications (and of all TI products used in or for Designers' applications) with all applicable regulations, laws and other applicable requirements. Designer represents that, with respect to their applications, Designer has all the necessary expertise to create and implement safeguards that (1) anticipate dangerous consequences of failures, (2) monitor failures and their consequences, and (3) lessen the likelihood of failures that might cause harm and take appropriate actions. Designer agrees that prior to using or distributing any applications that include TI products, Designer will thoroughly test such applications and the functionality of such TI products as used in such applications.

TI's provision of technical, application or other design advice, quality characterization, reliability data or other services or information, including, but not limited to, reference designs and materials relating to evaluation modules, (collectively, "TI Resources") are intended to assist designers who are developing applications that incorporate TI products; by downloading, accessing or using TI Resources in any way, Designer (individually or, if Designer is acting on behalf of a company, Designer's company) agrees to use any particular TI Resource solely for this purpose and subject to the terms of this Notice.

TI's provision of TI Resources does not expand or otherwise alter TI's applicable published warranties or warranty disclaimers for TI products, and no additional obligations or liabilities arise from TI providing such TI Resources. TI reserves the right to make corrections, enhancements, improvements and other changes to its TI Resources. TI has not conducted any testing other than that specifically described in the published documentation for a particular TI Resource.

Designer is authorized to use, copy and modify any individual TI Resource only in connection with the development of applications that include the TI product(s) identified in such TI Resource. NO OTHER LICENSE, EXPRESS OR IMPLIED, BY ESTOPPEL OR OTHERWISE TO ANY OTHER TI INTELLECTUAL PROPERTY RIGHT, AND NO LICENSE TO ANY TECHNOLOGY OR INTELLECTUAL PROPERTY RIGHT OF TI OR ANY THIRD PARTY IS GRANTED HEREIN, including but not limited to any patent right, copyright, mask work right, or other intellectual property right relating to any combination, machine, or process in which TI products or services are used. Information regarding or referencing third-party products or services does not constitute a license to use such products or services, or a warranty or endorsement thereof. Use of TI Resources may require a license from a third party under the patents or other intellectual property of the third party, or a license from TI under the patents or other intellectual property of TI.

TI RESOURCES ARE PROVIDED "AS IS" AND WITH ALL FAULTS. TI DISCLAIMS ALL OTHER WARRANTIES OR REPRESENTATIONS, EXPRESS OR IMPLIED, REGARDING RESOURCES OR USE THEREOF, INCLUDING BUT NOT LIMITED TO ACCURACY OR COMPLETENESS, TITLE, ANY EPIDEMIC FAILURE WARRANTY AND ANY IMPLIED WARRANTIES OF MERCHANTABILITY, FITNESS FOR A PARTICULAR PURPOSE, AND NON-INFRINGEMENT OF ANY THIRD PARTY INTELLECTUAL PROPERTY RIGHTS. TI SHALL NOT BE LIABLE FOR AND SHALL NOT DEFEND OR INDEMNIFY DESIGNER AGAINST ANY CLAIM, INCLUDING BUT NOT LIMITED TO ANY INFRINGEMENT CLAIM THAT RELATES TO OR IS BASED ON ANY COMBINATION OF PRODUCTS EVEN IF DESCRIBED IN TI RESOURCES OR OTHERWISE. IN NO EVENT SHALL TI BE LIABLE FOR ANY ACTUAL, DIRECT, SPECIAL, COLLATERAL, INDIRECT, PUNITIVE, INCIDENTAL, CONSEQUENTIAL OR EXEMPLARY DAMAGES IN CONNECTION WITH OR ARISING OUT OF TI RESOURCES OR USE THEREOF, AND REGARDLESS OF WHETHER TI HAS BEEN ADVISED OF THE POSSIBILITY OF SUCH DAMAGES.

Unless TI has explicitly designated an individual product as meeting the requirements of a particular industry standard (e.g., ISO/TS 16949 and ISO 26262), TI is not responsible for any failure to meet such industry standard requirements.

Where TI specifically promotes products as facilitating functional safety or as compliant with industry functional safety standards, such products are intended to help enable customers to design and create their own applications that meet applicable functional safety standards and requirements. Using products in an application does not by itself establish any safety features in the application. Designers must ensure compliance with safety-related requirements and standards applicable to their applications. Designer may not use any TI products in life-critical medical equipment unless authorized officers of the parties have executed a special contract specifically governing such use. Life-critical medical equipment is medical equipment where failure of such equipment would cause serious bodily injury or death (e.g., life support, pacemakers, defibrillators, heart pumps, neurostimulators, and implantables). Such equipment includes, without limitation, all medical devices identified by the U.S. Food and Drug Administration as Class III devices and equivalent classifications outside the U.S.

TI may expressly designate certain products as completing a particular qualification (e.g., Q100, Military Grade, or Enhanced Product). Designers agree that it has the necessary expertise to select the product with the appropriate qualification designation for their applications and that proper product selection is at Designers' own risk. Designers are solely responsible for compliance with all legal and regulatory requirements in connection with such selection.

Designer will fully indemnify TI and its representatives against any damages, costs, losses, and/or liabilities arising out of Designer's non-compliance with the terms and provisions of this Notice.

Looking for pricing, stock, or lifecycle information?

Click below to explore more details on WIN SOURCE:

 [View BQ27510DRZR-G3 on WIN SOURCE](#)

 [Texas Instruments](#) Information

Optimize Your Supply Chain with WIN SOURCE Solutions

-  Global Sourcing Solution
-  Obsolete Management
-  Cost Control Management
-  Shortage Management
-  Alternative Solution
-  Excess Inventory Management