



**THE DATASHEET OF  
BQ27410DRZR-G1**



## System-Side Impedance Track™ Fuel Gauge With Direct Battery Connection

### FEATURES

- **Battery Fuel Gauge for 1-Series LiCoO<sub>2</sub> battery Applications**
- **Easy to Configure Battery Fuel Gauging Based on Patented Impedance Track™ Technology**
  - **Models Battery Discharge Curve for Accurate State-of-Charge Report**
  - **Automatically Adjusts for Battery Aging, Battery Self-Discharge, and Temperature/Rate Inefficiencies**
  - **Low-Value Sense Resistor (5 mΩ or 20 mΩ)**
- **Resides on System Main Board**
  - **Works with Embedded or Removable Battery Packs**
  - **Integrated LDO allows devices to be powered directly from battery pack**
- **Microcontroller Peripheral Provides:**
  - **Accurate Battery Fuel Gauging**
  - **Internal Temperature Sensor for Battery Temperature Reporting**
  - **Configurable Level of State-of-Charge (SOC) Interrupts**
- **I<sup>2</sup>C™ for Connection to System Microcontroller Port**
- **Small 12-pin 2,5 mm × 4 mm SON Package**

### APPLICATIONS

- **Smartphones**
- **PDA's**
- **Digital Still and Video Cameras**
- **Handheld Terminals**
- **MP3 or Multimedia Players**

### DESCRIPTION

The Texas Instruments bq27410 system-side LiCoO<sub>2</sub> battery fuel gauge is an easy to configure microcontroller peripheral that provides fuel gauging for single-cell LiCoO<sub>2</sub> battery packs. The device requires minimal user configurations and system microcontroller firmware development for accurate fuel gauging.

The bq27410 uses the patented Impedance Track™ algorithm for fuel gauging, and provides information such as remaining battery capacity (mAh), state-of-charge (%), and battery voltage (mV).

Battery fuel gauging with the bq27410 requires only PACK+ (P+), PACK– (P–), for a removable battery pack or embedded battery circuit. The 12-pin SON package with dimensions of 2,5 mm × 4 mm with 0.5mm lead pitch is ideal for space constrained applications.

### TYPICAL APPLICATION

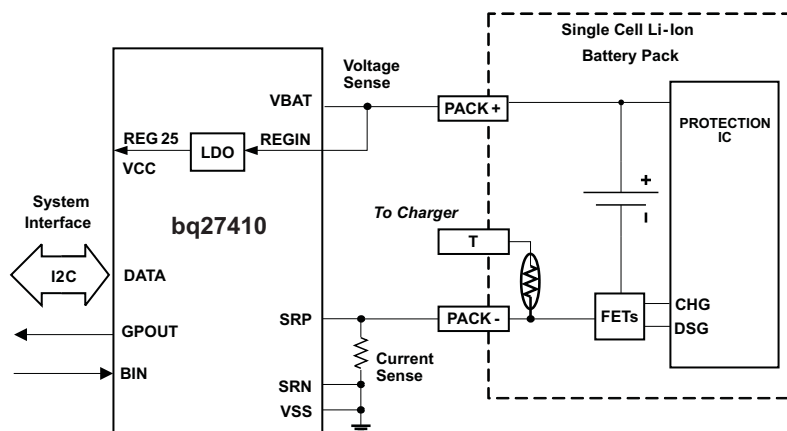

Please be aware that an important notice concerning availability, standard warranty, and use in critical applications of Texas Instruments semiconductor products and disclaimers thereto appears at the end of this data sheet.

Impedance Track is a trademark of Texas Instruments.  
I<sup>2</sup>C is a trademark of Phillips Corporation.



These devices have limited built-in ESD protection. The leads should be shorted together or the device placed in conductive foam during storage or handling to prevent electrostatic damage to the MOS gates.

## DEVICE INFORMATION

### AVAILABLE OPTIONS

PART NUMBER	PACKAGE <sup>(1)</sup>	T <sub>A</sub>	COMMUNICATION FORMAT	TAPE and REEL QUANTITY
bq27410DRZR-G1	12-pin, 2,5-mm × 4-mm SON	–40°C to 85°C	I <sup>2</sup> C	3000
bq27410DRZT-G1				250

(1) For the most current package and ordering information see the Package Option Addendum at the end of this document; or, see the TI website at [www.ti.com](http://www.ti.com).

### PIN DIAGRAM



### PIN FUNCTIONS

PIN		TYPE <sup>(1)</sup>	DESCRIPTION
NAME	NO.		
BIN	1	I	Battery-insertion detection input. A logic high to low transition is detected as a battery insertion event.
REG25	2	P	2.5 V output voltage of the internal integrated LDO.
REGIN	3	P	The input voltage for the internal integrated LDO.
BAT	4	I	Cell-voltage measurement input. ADC input. Recommend 4.8V maximum for conversion accuracy.
V <sub>cc</sub>	5	P	Processor power input. Decouple with minimum 0.1μF ceramic capacitor.
V <sub>ss</sub>	6	P	Device ground
SRP	7	IA	Analog input pin connected to the internal coulomb counter where SRP is nearest the PACK– connection. Connect to 5-mΩ to 20-mΩ sense resistor.
SRN	8	IA	Analog input pin connected to the internal coulomb counter where SRN is nearest the V <sub>ss</sub> connection. Connect to 5-mΩ to 20-mΩ sense resistor.
NC	9	O	No Connect.
SDA	10	I/O	Slave I2C serial communications data line for communication with system (Master). Open-drain I/O. Use with 10kΩ pull-up resistor (typical).
SCL	11	I	Slave I2C serial communications clock input line for communication with system (Master). Use with 10kΩ pull-up resistor (typical).
GPOUT	12	O	General Purpose open-drain output. May be configured as Battery Low indicator or perform SOC interrupt (SOC_INT) function.

(1) I/O = Digital input/output; IA = Analog input; P = Power connection.

## ELECTRICAL SPECIFICATIONS

### ABSOLUTE MAXIMUM RATINGS

over operating free-air temperature range (unless otherwise noted)<sup>(1)</sup>

		VALUE	UNIT
V <sub>CC</sub>	Supply voltage range	-0.3 to 2.75	V
V <sub>IOD</sub>	Open-drain I/O pins (SDA, SCL, GPOUT)	-0.3 to 6	V
V <sub>BAT</sub>	BAT input pin	-0.3 to 6	V
V <sub>I</sub>	Input voltage range to all other pins (BIN, SRP, SRN)	-0.3 to V <sub>CC</sub> + 0.3	V
ESD	Human Body Model (HBM), BAT pin	1.5	kV
	Human Body Model (HBM), all other pins	2	
T <sub>A</sub>	Operating free-air temperature range	-40 to 85	°C
T <sub>F</sub>	Functional temperature range	-40 to 100	°C
T <sub>STG</sub>	Storage temperature range	-65 to 150	°C

- (1) Stresses beyond those listed under *absolute maximum ratings* may cause permanent damage to the device. These are stress ratings only, and functional operation of the device at these or any other conditions beyond those indicated under *recommended operating conditions* is not implied. Exposure to absolute-maximum-rated conditions for extended periods may affect device reliability.

### THERMAL INFORMATION

THERMAL METRIC <sup>(1)</sup>		bq27410-G1	UNITS
		DRZ (12-PINS)	
θ <sub>JA</sub>	Junction-to-ambient thermal resistance	64.1	°C/W
θ <sub>JCtop</sub>	Junction-to-case (top) thermal resistance	59.8	
θ <sub>JB</sub>	Junction-to-board thermal resistance	52.7	
ψ <sub>JT</sub>	Junction-to-top characterization parameter	0.3	
ψ <sub>JB</sub>	Junction-to-board characterization parameter	28.3	
θ <sub>JCbot</sub>	Junction-to-case (bottom) thermal resistance	2.4	

- (1) For more information about traditional and new thermal metrics, see the *IC Package Thermal Metrics* application report, [SPRA953](#).

### RECOMMENDED OPERATING CONDITIONS AND DC CHARACTERISTICS

T<sub>A</sub> = -40°C to 85°C, 2.4 V < V<sub>CC</sub> < 2.6 V; typical values at T<sub>A</sub> = 25°C and V<sub>CC</sub> = 2.5 V (unless otherwise noted)

PARAMETER		TEST CONDITION	MIN	TYP	MAX	UNIT
V <sub>REGIN</sub>	Supply voltage	No operating restrictions	2.7		5.5	V
		No FLASH writes	2.45		2.7	
C <sub>REG25</sub>	External REG25 capacitor	C <sub>REG25</sub>	0.47			µF
I <sub>CC</sub>	Normal operating mode current	Fuel gauge in NORMAL mode, I <sub>LOAD</sub> > <b>Sleep Current</b>		103		µA
I <sub>SLP</sub>	Sleep operating mode current	Fuel gauge in SLEEP mode. I <sub>LOAD</sub> < <b>Sleep Current</b>		60		µA
I <sub>FULLSLP</sub>	Low-power operating mode current	Fuel gauge in FULLSLEEP mode. I <sub>LOAD</sub> < <b>Sleep Current</b>		18		µA
I <sub>HIB</sub>	Hibernate operating mode current	Fuel gauge in HIBERNATE mode. I <sub>LOAD</sub> < <b>Hibernate Current</b>		4		µA
V <sub>OL</sub>	Output voltage low (Digital pins)	I <sub>OL</sub> = 0.5 mA			0.4	V
V <sub>OH(OD)</sub>	Output high voltage (SDA, SCL, GPOUT)	External pull-up resistor connected to V <sub>CC</sub>	V <sub>CC</sub> -0.5			V
V <sub>IL</sub>	Input voltage low (SDA, SCL)		-0.3		0.6	V
	Input voltage low (BIN)		-0.3		0.6	
V <sub>IH(OD)</sub>	Input voltage high (SDA, SCL)		1.2		6	V
	Input voltage high (BIN)		1.2		V <sub>CC</sub> +0.3	
V <sub>A2</sub>	Input voltage range (BAT)		V <sub>SS</sub> -0.125		5	V
V <sub>A3</sub>	Input voltage range (SRP, SRN)		V <sub>SS</sub> -0.125		0.125	V
I <sub>ikg</sub>	Input leakage current (I/O pins)				0.3	µA
t <sub>PUCD</sub>	Power-up communication delay			250		ms

## 2.5 V LDO <sup>(1)</sup>

$T_A = -40^{\circ}\text{C}$  to  $85^{\circ}\text{C}$ , typical values at  $T_A = 25^{\circ}\text{C}$ ,  $C_{REG} = 0.47\mu\text{F}$  and  $V_{BAT} = 3.6\text{ V}$  (unless otherwise noted)

PARAMETER	TEST CONDITION	MIN	NOM	MAX	UNIT
$V_{REG25}$ Regulator output voltage	$2.7\text{ V} \leq V_{REGIN} \leq 5.5\text{ V}$ , $I_{OUT} \leq 16\text{ mA}$	2.4	2.5	2.6	V
	$2.45\text{ V} \leq V_{REGIN} < 2.7\text{ V}$ (low battery), $I_{OUT} \leq 3\text{ mA}$	2.4			V
$V_{DO}$ Regulator dropout voltage	$2.7\text{ V}$ , $I_{OUT} \leq 16\text{ mA}$			280	mV
	$2.45\text{ V}$ , $I_{OUT} \leq 3\text{ mA}$			50	
$\Delta V_{REGTEMP}$ Regulator output change with temperature	$V_{REGIN} = 3.6\text{ V}$ , $I_{OUT} = 16\text{ mA}$		0.3%		
$\Delta V_{REGLINE}$ Line regulation	$2.7\text{ V} \leq V_{REGIN} \leq 5.5\text{ V}$ , $I_{OUT} = 16\text{ mA}$ , $T_A = 25^{\circ}\text{C}$		11	25	mV
$\Delta V_{REGLOAD}$ Load regulation	$0.2\text{ mA} \leq I_{OUT} \leq 3\text{ mA}$ , $V_{REGIN} = 2.45\text{ V}$ , $T_A = 25^{\circ}\text{C}$		34	40	mV
	$3\text{ mA} \leq I_{OUT} \leq 16\text{ mA}$ , $V_{REGIN} = 2.7\text{ V}$ , $T_A = 25^{\circ}\text{C}$		31		
$I_{SHORT}$ <sup>(2)</sup> Short circuit current limit	$V_{REG25} = 0\text{ V}$ , $T_A = -40^{\circ}\text{C}$ to $85^{\circ}\text{C}$			250	mA

(1) LDO output current,  $I_{OUT}$ , is the sum of internal and external load currents.

(2) Assured by design. Not production tested.

## POWER-ON RESET

$T_A = -40^{\circ}\text{C}$  to  $85^{\circ}\text{C}$ , typical values at  $T_A = 25^{\circ}\text{C}$  and  $V_{BAT} = 3.6\text{ V}$  (unless otherwise noted)

PARAMETER	TEST CONDITIONS	MIN	TYP	MAX	UNIT
$V_{IT+}$ Positive-going battery voltage input at $V_{CC}$		2.09	2.20	2.31	V
$V_{HYS}$ Power-on reset hysteresis		45	115	185	mV

## INTERNAL TEMPERATURE SENSOR CHARACTERISTICS

$T_A = -40^{\circ}\text{C}$  to  $85^{\circ}\text{C}$ ,  $2.4\text{ V} < V_{CC} < 2.6\text{ V}$ ; typical values at  $T_A = 25^{\circ}\text{C}$  and  $V_{CC} = 2.5\text{ V}$  (unless otherwise noted)

PARAMETER	TEST CONDITIONS	MIN	TYP	MAX	UNIT
$G_{TEMP}$ Temperature sensor voltage gain			-2		mV/ $^{\circ}\text{C}$

## HIGH FREQUENCY OSCILLATOR

$T_A = -40^{\circ}\text{C}$  to  $85^{\circ}\text{C}$ ,  $2.4\text{ V} < V_{CC} < 2.6\text{ V}$ ; typical values at  $T_A = 25^{\circ}\text{C}$  and  $V_{CC} = 2.5\text{ V}$  (unless otherwise noted)

PARAMETER	TEST CONDITIONS	MIN	TYP	MAX	UNIT
$f_{OSC}$ Operating frequency			2.097		MHz
$f_{EIO}$ Frequency error <sup>(1)</sup> <sup>(2)</sup>	$T_A = 0^{\circ}\text{C}$ to $60^{\circ}\text{C}$	-2.0%	0.38%	2.0%	
	$T_A = -20^{\circ}\text{C}$ to $70^{\circ}\text{C}$	-3.0%	0.38%	3.0%	
	$T_A = -40^{\circ}\text{C}$ to $85^{\circ}\text{C}$	-4.5%	0.38%	4.5%	
$t_{SXO}$ Start-up time <sup>(3)</sup>			2.5	5	ms

(1) The frequency error is measured from 2.097 MHz.

(2) The frequency drift is included and measured from the trimmed frequency at  $V_{CC} = 2.5\text{ V}$ ,  $T_A = 25^{\circ}\text{C}$ .

(3) The startup time is defined as the time it takes for the oscillator output frequency to be  $\pm 3\%$  of typical oscillator frequency.

## LOW FREQUENCY OSCILLATOR

$T_A = -40^\circ\text{C}$  to  $85^\circ\text{C}$ ,  $2.4\text{ V} < V_{CC} < 2.6\text{ V}$ ; typical values at  $T_A = 25^\circ\text{C}$  and  $V_{CC} = 2.5\text{ V}$  (unless otherwise noted)

PARAMETER	TEST CONDITIONS	MIN	TYP	MAX	UNIT
$f_{\text{OSC}}$ Operating frequency			32.76 8		kHz
$f_{\text{EIO}}$ Frequency error <sup>(1) (2)</sup>	$T_A = 0^\circ\text{C}$ to $60^\circ\text{C}$	-1.5%	0.25%	1.5%	
	$T_A = -20^\circ\text{C}$ to $70^\circ\text{C}$	-2.5%	0.25%	2.5%	
	$T_A = -40^\circ\text{C}$ to $85^\circ\text{C}$	-4.0%	0.25%	4.0%	
$t_{\text{LSXO}}$ Start-up time <sup>(3)</sup>				500	$\mu\text{s}$

(1) The frequency drift is included and measured from the trimmed frequency at  $V_{CC} = 2.5\text{ V}$ ,  $T_A = 25^\circ\text{C}$ .

(2) The frequency error is measured from 32.768 kHz.

(3) The startup time is defined as the time it takes for the oscillator output frequency to be  $\pm 3\%$  of typical oscillator frequency.

## INTEGRATING ADC (COULOMB COUNTER) CHARACTERISTICS

$T_A = -40^\circ\text{C}$  to  $85^\circ\text{C}$ ,  $2.4\text{ V} < V_{CC} < 2.6\text{ V}$ ; typical values at  $T_A = 25^\circ\text{C}$  and  $V_{CC} = 2.5\text{ V}$  (unless otherwise noted)

PARAMETER	TEST CONDITIONS	MIN	TYP	MAX	UNIT
$V_{\text{SR\_IN}}$ Input voltage range, $V_{\text{(SRN)}}$ and $V_{\text{(SRP)}}$	$V_{\text{SR}} = V_{\text{(SRN)}} - V_{\text{(SRP)}}$	-0.125		0.125	V
$t_{\text{SR\_CONV}}$ Conversion time	Single conversion		1		s
Resolution		14		15	bits
$V_{\text{SR\_OS}}$ Input offset			10		$\mu\text{V}$
INL Integral nonlinearity error			$\pm 0.007$	$\pm 0.034$	%FSR
$Z_{\text{SR\_IN}}$ Effective input resistance <sup>(1)</sup>		2.5			$\text{M}\Omega$
$I_{\text{SR\_LKG}}$ Input leakage current <sup>(1)</sup>				0.3	$\mu\text{A}$

(1) Assured by design. Not production tested.

## ADC (TEMPERATURE AND CELL MEASUREMENT) CHARACTERISTICS

$T_A = -40^\circ\text{C}$  to  $85^\circ\text{C}$ ,  $2.4\text{ V} < V_{CC} < 2.6\text{ V}$ ; typical values at  $T_A = 25^\circ\text{C}$  and  $V_{CC} = 2.5\text{ V}$  (unless otherwise noted)

PARAMETER	TEST CONDITIONS	MIN	TYP	MAX	UNIT
$V_{\text{ADC\_IN}}$ Input voltage range		-0.2		1	V
$t_{\text{ADC\_CONV}}$ Conversion time				125	ms
	Resolution	14		15	bits
$V_{\text{ADC\_OS}}$ Input offset			1		mV
$Z_{\text{ADC1}}$ Effective input resistance (TS) <sup>(1)</sup>		8			$\text{M}\Omega$
$Z_{\text{ADC2}}$ Effective input resistance (BAT) <sup>(1)</sup>	bq27410 not measuring cell voltage	8			$\text{M}\Omega$
	bq27410 measuring cell voltage		100		k $\Omega$
$I_{\text{ADC\_LKG}}$ Input leakage current <sup>(1)</sup>				0.3	$\mu\text{A}$

(1) Assured by design. Not production tested.

## DATA FLASH MEMORY CHARACTERISTICS

$T_A = -40^\circ\text{C}$  to  $85^\circ\text{C}$ ,  $2.4\text{ V} < V_{CC} < 2.6\text{ V}$ ; typical values at  $T_A = 25^\circ\text{C}$  and  $V_{CC} = 2.5\text{ V}$  (unless otherwise noted)

PARAMETER	TEST CONDITIONS	MIN	TYP	MAX	UNIT
$t_{\text{DR}}$ Data retention <sup>(1)</sup>		10			Years
	Flash programming write-cycles <sup>(1)</sup>	20,000			Cycles
$t_{\text{WORDPROG}}$ Word programming time <sup>(1)</sup>				2	ms
$I_{\text{CCPROG}}$ Flash-write supply current <sup>(1)</sup>			5	10	mA

(1) Assured by design. Not production tested.

## 400 kHz I<sup>2</sup>C-COMPATIBLE INTERFACE COMMUNICATION TIMING CHARACTERISTICS

$T_A = -40^{\circ}\text{C}$  to  $85^{\circ}\text{C}$ ,  $2.4\text{ V} < V_{CC} < 2.6\text{ V}$ ; typical values at  $T_A = 25^{\circ}\text{C}$  and  $V_{CC} = 2.5\text{ V}$  (unless otherwise noted)

PARAMETER		TEST CONDITIONS	MIN	TYP	MAX	UNIT
$t_r$	SCL/SDA rise time				300	ns
$t_f$	SCL/SDA fall time				300	ns
$t_{w(H)}$	SCL pulse width (high)		600			ns
$t_{w(L)}$	SCL pulse width (low)		1.3			$\mu\text{s}$
$t_{su(STA)}$	Setup for repeated start		600			ns
$t_{d(STA)}$	Start to first falling edge of SCL		600			ns
$t_{su(DAT)}$	Data setup time		100			ns
$t_{h(DAT)}$	Data hold time		0			ns
$t_{su(STOP)}$	Setup time for stop		600			ns
$t_{BUF}$	Bus free time between stop and start		1.3			$\mu\text{s}$
$f_{SCL}$	Clock frequency				400	kHz

## 100 kHz I<sup>2</sup>C-COMPATIBLE INTERFACE COMMUNICATION TIMING CHARACTERISTICS

$T_A = -40^{\circ}\text{C}$  to  $85^{\circ}\text{C}$ ,  $2.4\text{ V} < V_{CC} < 2.6\text{ V}$ ; typical values at  $T_A = 25^{\circ}\text{C}$  and  $V_{CC} = 2.5\text{ V}$  (unless otherwise noted)

PARAMETER		TEST CONDITIONS	MIN	TYP	MAX	UNIT
$t_r$	SCL/SDA rise time				1	$\mu\text{s}$
$t_f$	SCL/SDA fall time				300	ns
$t_{w(H)}$	SCL pulse width (high)		4			$\mu\text{s}$
$t_{w(L)}$	SCL pulse width (low)		4.7			$\mu\text{s}$
$t_{su(STA)}$	Setup for repeated start		4.7			$\mu\text{s}$
$t_{d(STA)}$	Start to first falling edge of SCL		4			$\mu\text{s}$
$t_{su(DAT)}$	Data setup time		250			ns
$t_{h(DAT)}$	Data hold time		0			ns
$t_{su(STOP)}$	Setup time for stop		4			$\mu\text{s}$
$t_{BUF}$	Bus free time between stop and start		4.7			$\mu\text{s}$
$f_{SCL}$	Clock frequency				100	kHz

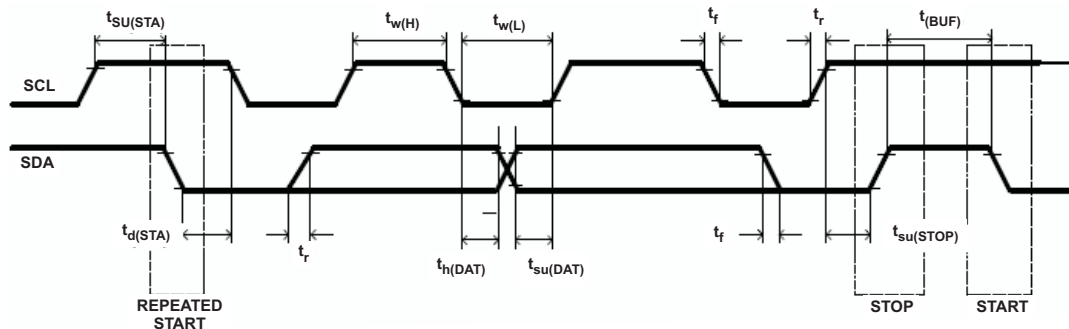

Figure 1. I<sup>2</sup>C-Compatible Interface Timing Diagrams

## GENERAL DESCRIPTION

The bq27410 accurately predicts the battery capacity and other operational characteristics of a single LiCoO<sub>2</sub> rechargeable cell. It can be interrogated by a system processor to provide cell information, such as state-of-charge (SOC).

Information is accessed through a series of commands, called *Standard Commands*. Further capabilities are provided by the additional *Extended Commands* set. Both sets of commands, indicated by the general format *Command( )*, are used to read and write information contained within the bq27410 control and status registers, as well as its data flash locations. Commands are sent from system to gauge using the bq27410's I<sup>2</sup>C serial communications engine, and can be executed during application development, pack manufacture, or end-equipment operation.

The key to the bq27410's high-accuracy gas gauging prediction is Texas Instrument's proprietary Impedance Track™ algorithm. This algorithm uses cell measurements, characteristics, and properties to create state-of-charge predictions that can achieve high accuracy across a wide variety of operating conditions and over the lifetime of the battery.

The bq27410 measures charge/discharge activity by monitoring the voltage across a small-value series sense resistor (5 mΩ to 20 mΩ typ.) located between the system's V<sub>SS</sub> and the battery's PACK– terminal. When a cell is attached to the bq27410, cell impedance is computed, based on cell current, cell open-circuit voltage (OCV), and cell voltage under loading conditions.

The bq27410 utilizes an integrated temperature sensor for estimating cell temperature. Alternatively, the host processor can provide temperature data for the bq27410.

To minimize power consumption, the bq27410 has several power modes: INITIALIZATION, NORMAL, SLEEP, FULLSLEEP, and HIBERNATE. The bq27410 passes automatically between these modes, depending upon the occurrence of specific events, though a system processor can initiate some of these modes directly. More details can be found in Section *Power Modes*.

---

### NOTE

#### FORMATTING CONVENTIONS IN THIS DOCUMENT:

Commands: *italics* with *parentheses* and no breaking spaces, e.g. *RemainingCapacity( )*.

Data Flash: *italics*, **bold**, and *breaking spaces*, e.g. **Design Capacity**.

Register bits and flags: brackets and *italics*, e.g. [TDA]

Data flash bits: brackets, *italics* and **bold**, e.g. [LED1]

Modes and states: ALL CAPITALS, e.g. UNSEALED mode.

---

## DATA COMMANDS

### Standard Data Commands

The bq27410 uses a series of 2-byte standard commands to enable system reading and writing of battery information. Each standard command has an associated command-code pair, as indicated in [Table 1](#). Because each command consists of two bytes of data, two consecutive I<sup>2</sup>C transmissions must be executed both to initiate the command function, and to read or write the corresponding two bytes of data. Additional options for transferring data, such as spooling, are described in Section, *I<sup>2</sup>C INTERFACE*. Standard commands are accessible in NORMAL operation. Read/Write permissions depend on the active access mode, SEALED or UNSEALED (for details on the SEALED and UNSEALED states, refer to Section *Access Modes*.)

**Table 1. Standard Commands**

NAME		COMMAND CODE	UNITS	SEALED ACCESS
<i>Control()</i>	CNTL	0x00 / 0x01	N/A	R/W
<i>Temperature()</i>	TEMP	0x02 / 0x03	0.1°K	R/W
<i>Voltage()</i>	VOLT	0x04 / 0x05	mV	R
<i>Flags()</i>	FLAGS	0x06 / 0x07	N/A	R
<i>NominalAvailableCapacity()</i>	NAC	0x08 / 0x09	mAh	R
<i>FullAvailableCapacity()</i>	FAC	0x0a / 0x0b	mAh	R
<i>RemainingCapacity()</i>	RM	0x0c / 0x0d	mAh	R
<i>FullChargeCapacity()</i>	FCC	0x0e / 0x0f	mAh	R
<i>AverageCurrent()</i>	AI	0x10 / 0x11	mA	R
<i>StandbyCurrent()</i>	SI	0x12 / 0x13	mA	R
<i>MaxLoadCurrent()</i>	MLI	0x14 / 0x15	mA	R
<i>AvailableEnergy()</i>	AE	0x16 / 0x17	10mWhr	R
<i>AveragePower()</i>	AP	0x18 / 0x19	10mW	R
<i>StateOfCharge()</i>	SOC	0x1c / 0x1d	%	R
<i>IntTemperature()</i>	ITEMP	0x1e / 0x1f	0.1°K	R
<i>StateofHealth()</i>	SCH	0x20 / 0x21	%	R

#### **Control(): 0x00/0x01**

Issuing a *Control()* command requires a subsequent 2-byte subcommand. These additional bytes specify the particular control function desired. The *Control()* command allows the system to control specific features of the bq27410 during normal operation and additional features when the bq27410 is in different access modes, as described in [Table 2](#).

**Table 2. Control() Subcommands**

CNTL FUNCTION	CNTL DATA	SEALED ACCESS	DESCRIPTION
CONTROL_STATUS	0x0000	Yes	Reports the status of device.
DEVICE_TYPE	0x0001	Yes	Reports the device type (0x0410).
FW_VERSION	0x0002	Yes	Reports the firmware version on the device type.
HW_VERSION	0x0003	Yes	Reports the hardware version of the device type.
PREV_MACWRITE	0x0007	No	Returns previous MAC command code.
BAT_INSERT	0x000c	Yes	Forces the [BAT_DET] bit set when the [BIE] bit is 0.
BAT_REMOVE	0x000d	Yes	Forces the [BAT_DET] bit clear when the [BIE] bit is 0.
SET_FULLSLEEP	0x0010	Yes	Set CONTROL_STATUS [FULLSLEEP] to 1.
SET_HIBERNATE	0x0011	Yes	Forces CONTROL_STATUS [HIBERNATE] to 1.
CLEAR_HIBERNATE	0x0012	Yes	Forces CONTROL_STATUS [HIBERNATE] to 0.
FACTORY_RESTORE	0x0015	No	Forces a Factory Restore of learned resistance and Qmax to defaults.
SEALED	0x0020	No	Places the bq27410 in SEALED access mode.
RESET	0x0041	No	Forces a full reset of the bq27410.

**CONTROL\_STATUS: 0x0000**

Instructs the fuel gauge to return status information to control addresses 0x00/0x01. The status word includes the following information.

**Table 3. CONTROL\_STATUS Bit Definitions**

	bit7	bit6	bit5	bit4	bit3	bit2	bit1	bit0
High Byte	HIBE	FAS	SS	RSVD	CCA	RSVD	QMAXU	RESU
Low Byte	INITCOMP	HIBERNATE	FULLSLEEP	SLEEP	RSVD	RUP_DIS	VOK	RSVD

HIBE = Status bit indicating that Hibernate mode has been Entered. The bit is cleared if a CLEAR\_HIBERNATE subcommand is received. Active when set.

FAS = Status bit indicating the bq27410 is in FULL ACCESS SEALED state. Active when set.

SS = Status bit indicating the bq27410 is in the SEALED State. Active when set.

CCA = Status bit indicating the bq27410 Coulomb Counter Auto-Calibration routine is active. The CCA routine will take place approximately 3 minutes and 45 seconds after the initialization. Active when set.

QMAXU = Status bit indicating Qmax has Updated. True when set. This bit is cleared after power on reset or when [BAT\_DET] bit is set. When this bit is cleared, it enables fast learning of battery Qmax.

RESU = Status bit indicating that resistance has been updated. True when set. This bit is cleared after power on reset or when [BAT\_DET] bit is set. Also this bit can only be set after Qmax is updated or QMAXU is set. When this bit is cleared, it enables fast learning of battery impedance.

INITCOMP = Initialization completion bit indicating the initialization completed. True when set.

HIBERNATE = Status bit indicating a request for entry into HIBERNATE from SLEEP mode has been issued. True when set. Default is 0.

FULLSLEEP = Status bit indicating the BQ27410 is in FULLSLEEP mode. True when set. The state can be detected by monitoring the power used by the BQ27410 because any communication will automatically clear it.

SLEEP = Status bit indicating the bq27410 is in SLEEP mode. True when set.

RSVD (bit 3) = This bit reserved and may change state at any time during device operation.

RUP\_DIS = Status bit indicating the bq27410 Ra table updates are disabled. Updates disabled when set..

VOK = Status bit indicating cell voltages are OK for Qmax updates. True when set.

RSVD = Reserved for future use.

**DEVICE\_TYPE: 0x0001**

Instructs the fuel gauge to return the device type to addresses 0x00/0x01.

**FW\_VERSION: 0x0002**

Instructs the fuel gauge to return the firmware version to addresses 0x00/0x01.

**HW\_VERSION: 0x0003**

Instructs the fuel gauge to return the hardware version to addresses 0x00/0x01.

**PREV\_MACWRITE: 0x0007**

Instructs the fuel gauge to return the previous command written to addresses 0x00/0x01. The value returned is limited to less than 0x0015.

**BAT\_INSERT: 0X000C**

This subcommand forces the *Flags()* [BAT\_DET] bit to set when the battery insertion detection is disabled via **OpConfig[BIE=0]**. In this case, the gauge does not detect battery insertion from the BIN pin's logic state, but relies on the BAT\_INSERT host subcommand to indicate battery presence in the system. This subcommand also starts Impedance Track™ gauging.

**BAT\_REMOVE: 0X000D**

This subcommand forces the *Flags()* [BAT\_DET] bit to clear when the battery insertion detection is disabled via **OpConfig[BIE=0]**. In this case, the gauge does not detect battery removal from the BIN pin's logic state, but relies on the BAT\_REMOVE host subcommand to indicate battery removal from the system.

**SET\_FULLSLEEP: 0x0010**

Instructs the gas gauge to set the CONTROL\_STATUS [*FULLSLEEP*] bit to 1. This allows the gauge to enter the FULLSLEEP power mode after the transition to SLEEP power state is detected. In FULLSLEEP mode less power is consumed by disabling the high frequency oscillator circuit used by the communication engines. For I2C communications, the first I2C message will incur a 6 - 8 millisecond clock stretch while the oscillator is started and stabilized. A communication to the device in FULLSLEEP will force the device back to the SLEEP mode.

**SET\_HIBERNATE: 0x0011**

Instructs the fuel gauge to force the CONTROL\_STATUS [*HIBERNATE*] bit to 1. This allows the gauge to enter the HIBERNATE power mode after the transition to SLEEP power state is detected. The [*HIBERNATE*] bit is automatically cleared upon exiting from HIBERNATE mode.

**CLEAR\_HIBERNATE: 0x0012**

Instructs the fuel gauge to force the CONTROL\_STATUS [*HIBERNATE*] and [*HIBE*] bit to 0. This prevents the gauge from entering the HIBERNATE power mode after the transition to SLEEP power state is detected. It can also be used to force the gauge out of HIBERNATE mode.

**FACTORY\_RESTORE: 0X0015**

Instructs the fuel gauge to reset learned resistance tables and Qmax values (default = **DesignCapacity**) to the default values. This command is only available when the fuel gauge is UNSEALED.

**SEALED: 0x0020**

Instructs the fuel gauge to transition from UNSEALED state to SEALED state. The fuel gauge should always be set to SEALED state for use in end equipment.

**RESET : 0x0041**

This command instructs the fuel gauge to perform a full reset. This command is only available when the fuel gauge is UNSEALED.

**Temperature( ): 0x02/0x03**

This read-/write-word function returns an unsigned integer value of the temperature in units of 0.1 K measured by the fuel gauge. If [WRTEMP] bit = 1, a write command sets the temperature to be used for gauging calculations while a read command returns to temperature previously written. If [WRTEMP] bit = 0, a read command will return the internal temperature sensor value and write command will be ignored.

**Voltage( ): 0x04/0x05**

This read-only function returns an unsigned integer value of the measured cell-pack voltage in mV with a range of 0 to 6000 mV.

**Flags( ): 0x06/0x07**

This read-word function returns the contents of the gas-gauge status register, depicting the current operating status.

**Table 4. Flags Bit Definitions**

	bit7	bit6	bit5	bit4	bit3	bit2	bit1	bit0
High Byte	OTC	OTD	RSVD	RSVD	CHG_INH	RSVD	FC	CHG
Low Byte	OCVTAKEN	RSVD	RSVD	RSVD	BAT_DET	SOC1	SOCF	DSG

OTC = Over-Temperature in charge condition is detected. True when set. See [Over-Temperature Indication: Charge](#) Sub-Section.

OTD = Over-Temperature in discharge condition is detected. True when set. See [Over-Temperature Indication: Discharge](#) Sub-Section.

CHG\_INH = Charge Inhibit indicates the temperature is outside the range. True when set. See [Charge Inhibit](#) Sub-Section.

FC = Full-charged condition reached. True when set.

CHG = (Fast) charging allowed. True when set.

OCVTAKEN = Cleared on entry to relax mode and Set to 1 when OCV measurement is performed in relax

BAT\_DET = Battery insertion detected. True when set. When **OpConfig[BIE]** is set, **[BAT\_DET]** is set by detecting a logic high to low transition at BIN pin. when **OpConfig[BIE]** is low, **[BAT\_DET]** is set when host issues BAT\_INSERT subcommand and clear when host issues BAT\_REMOVE subcommand.

SOC1 = If set, *RemainingCapacity()* <= **SOC1 Set Threshold** (default = 150mAh). The [SOC1] bit will remain set until *RemainingCapacity()* >= **SOC1 Clear Threshold** (default = 175mAh).

SOCF = If set, *RemainingCapacity()* <= **SOCF Set Threshold** (default = 75mAh). The [SOCF] bit will remain set until *RemainingCapacity()* >= **SOCF Clear Threshold** (default = 100mAh).

DSG = Discharging detected. True when set.

### **NominalAvailableCapacity( ): 0x08/0x09**

This read-only command pair returns the uncompensated (less than C/20 load) battery capacity remaining. Units are mAh.

### **FullAvailableCapacity( ): 0x0a/0x0b**

This read-only command pair returns the uncompensated (less than C/20 load) capacity of the battery when fully charged. Units are mAh. *FullAvailableCapacity( )* is updated at regular intervals, as specified by the IT algorithm.

### **RemainingCapacity( ): 0x0c/0x0d**

This read-only command pair returns the compensated battery capacity remaining. Units are mAh.

### **FullChargeCapacity( ): 0x0e/0f**

This read-only command pair returns the compensated capacity of the battery when fully charged. Units are mAh. *FullChargeCapacity( )* is updated at regular intervals, as specified by the IT algorithm.

### **AverageCurrent( ): 0x10/0x11**

This read-only command pair returns a signed integer value that is the average current flow through the sense resistor. It is updated every 1 second. Units are mA.

### **StandbyCurrent( ): 0x12/0x13**

This read-only function returns a signed integer value of the measured standby current through the sense resistor. The *StandbyCurrent( )* is an adaptive measurement. Initially it reports the standby current programmed in **Initial Standby** (default = -10mA), and after spending some time in standby, reports the measured standby current.

The register value is updated every 1 second when the measured current is above the **Deadband** (= ±5mA) and is less than or equal to 2 x **Initial Standby (default = -10mA)**. The first and last values that meet this criteria are not averaged in, since they may not be stable values. To approximate a 1-minute time constant, each new *StandbyCurrent( )* value is computed by taking approximate 93% weight of the last standby current and approximate 7% of the current measured average current.

### **MaxLoadCurrent( ): 0x14/0x15**

This read-only function returns a signed integer value, in units of mA, of the maximum load conditions. The *MaxLoadCurrent( )* is an adaptive measurement which is initially reported as the maximum load current programmed in **Initial Max Load Current** (default = -500mA). If the measured current is ever greater than **Initial Max Load Current**, then *MaxLoadCurrent( )* updates to the new current. *MaxLoadCurrent( )* is reduced to the average of the previous value and **Initial Max Load Current** whenever the battery is charged to full after a previous discharge to an SOC less than 50%. This prevents the reported value from maintaining an unusually high value.

### **AvailableEnergy( ): 0x16/0x17**

This read-only function returns an unsigned integer value of the predicted charge or energy remaining in the battery. The value is reported in units of mWh.

**AveragePower( ): 0x18/0x19**

This read-only function returns an signed integer value of the average power during battery charging and discharging. It is negative during discharge and positive during charge. A value of 0 indicates that the battery is not being discharged. The value is reported in units of mW.

**StateOfCharge( ): 0x1c/0x1d**

This read-only function returns an unsigned integer value of the predicted remaining battery capacity expressed as a percentage of *FullChargeCapacity( )*, with a range of 0 to 100%.

**IntTemperature( ): 0x1e/0x1f**

This read-/write-word function returns an unsigned integer value of the internal temperature sensor in units of 0.1 K measured by the fuel gauge. If **OpConfig[WRTEMP]** = 0, this command will return the same value as *Temperature( )*.

**StateofHealth( ): 0x20/0x21**

0x20 SOH percentage: this read-only function returns an unsigned integer value, expressed as a percentage of the ratio of predicted FCC(25°C, **SOH LoadI**) over the *DesignCapacity()*. The FCC(25°C, **SOH LoadI**) is the calculated full charge capacity at 25°C and the **SOH LoadI** which is programmed in factory (default = -400mA). The range of the returned SOH percentage is 0x00 to 0x64, indicating 0 to 100% correspondingly.

0x21 SOH Status: this read-only function returns an unsigned integer value, indicating the status of the SOH percentage. The meanings of the returned value are:

- 0x00: SOH not valid (initialization)
- 0x01: Instant SOH value ready
- 0x02: Initial SOH value ready
  - Calculation based on uncompensated Qmax
  - Updated at first grid point update after cell insertion
- 0x03: SOH value ready
  - Utilize the updated Qmax update
  - Calculation based on compensated Qmax
  - Updated after complete charge and relax is complete
- 0x04-0xFF: Reserved

**Extended Data Commands**

Extended commands offer additional functionality beyond the standard set of commands. They are used in the same manner; however unlike standard commands, extended commands are not limited to 2-byte words. The number of command bytes for a given extended command ranges in size from single to multiple bytes, as specified in [Table 5](#).

**Table 5. Extended Commands**

NAME	COMMAND CODE	UNITS	SEALED ACCESS <sup>(1)</sup> (2)	UNSEALED ACCESS <sup>(1)</sup> (2)
<i>OperationConfiguration( )</i>	OPCFG	0x3a / 0x3b	N/A	R/W
<i>DesignCapacity( )</i>	DCAP	0x3c / 0x3d	mAh	R/W
<i>DataFlashClass( )</i> <sup>(2)</sup>	DFCLS	0x3e	N/A	R/W
<i>DataFlashBlock( )</i> <sup>(2)</sup>	DFBLK	0x3f	N/A	R/W
<i>BlockData( )</i>	DFD	0x40...0x5f	N/A	R/W
<i>BlockDataCheckSum( )</i>	DFDCKS	0x60	N/A	R/W
<i>BlockDataControl( )</i>	DFDCNTL	0x61	N/A	R/W
<i>DeviceNameLength( )</i>	DNAMELEN	0x62	N/A	R
<i>DeviceName( )</i>	DNAME	0x63...0x69	N/A	R
Reserved	RSVD	0x6a...0x7f	N/A	R

(1) SEALED and UNSEALED states are entered via commands to **Control( )** 0x00/0x01

(2) In sealed mode, data flash CANNOT be accessed through commands 0x3e and 0x3f.

#### ***OperationConfiguration( )*: 0x3a/0x3b**

SEALED and UNSEALED Access: This command returns the **Operation Configuration** register setting

#### ***DesignCapacity( )*: 0x3c/0x3d**

SEALED and UNSEALED Access: This command returns the value is stored in **Design Capacity** and is expressed in mAh. This is intended to be the theoretical or nominal capacity of a new pack and is used as an input for the algorithm to scale the normalized resistance tables.

#### ***DataFlashClass( )*: 0x3e**

UNSEALED Access: This command sets the data flash class to be accessed. The class to be accessed should be entered in hexadecimal.

SEALED Access: This command is not available in SEALED mode.

#### ***DataFlashBlock( )*: 0x3f**

UNSEALED Access: This command sets the data flash block to be accessed. When 0x00 is written to *BlockDataControl( )*, *DataFlashBlock( )* holds the block number of the data flash to be read or written. Example: writing a 0x00 to *DataFlashBlock( )* specifies access to the first 32 byte block and a 0x01 specifies access to the second 32 byte block, and so on.

SEALED Access: This command directs which data flash block will be accessed by the *BlockData( )* command. Issuing a 0x01 instructs the *BlockData( )* command to transfer **Manufacturer Info Block A**.

#### ***BlockData( )*: 0x40...0x5f**

UNSEALED Access: This data block is the remainder of the 32 byte data block when accessing data flash.

SEALED Access: This data block is the remainder of the 32 byte data block when accessing **Manufacturer Block Info A**.

#### ***BlockDataChecksum( )*: 0x60**

UNSEALED Access: This byte contains the checksum on the 32 bytes of block data read or written to data flash. The least-significant byte of the sum of the data bytes written must be complemented (  $[255 - x]$  , for x the least-significant byte) before being written to 0x60.

SEALED Access: This byte contains the checksum for the 32 bytes of block data written to **Manufacturer Info Block A**. The least-significant byte of the sum of the data bytes written must be complemented (  $[255 - x]$  , for x the least-significant byte) before being written to 0x60.

**BlockDataControl( ): 0x61**

UNSEALED Access: This command is used to control data flash access mode. Writing 0x00 to this command enables *BlockData( )* to access general data flash. Writing a 0x01 to this command enables SEALED mode operation of *DataFlashBlock( )*.

SEALED Access: This command is not available in SEALED mode.

**DeviceNameLength( ): 0x62**

UNSEALED and SEALED Access: This byte contains the length of the **Device Name**.

**DeviceName( ): 0x63...0x69**

UNSEALED and SEALED Access: This block contains the device name that is programmed in **Device Name**

**Reserved – 0x6a – 0x7f****DATA FLASH INTERFACE****Accessing the Data Flash**

The bq27410 data flash is a non-volatile memory that contains bq27410 initialization, default, cell status, calibration, configuration, and user information. The data flash can be accessed in several different ways, depending on what mode the bq27410 is operating in and what data is being accessed.

Commonly accessed data flash memory locations, frequently read by a system, are conveniently accessed through specific instructions, already described in Section *Data Commands*. These commands are available when the bq27410 is either in UNSEALED or SEALED modes.

Most data flash locations, however, are only accessible in UNSEALED mode by use of the bq27410 evaluation software or by data flash block transfers. These locations should be optimized and/or fixed during the development and manufacture processes. They become part of a golden image file and can then be written to multiple battery packs. Once established, the values generally remain unchanged during end-equipment operation.

To access data flash locations individually, the block containing the desired data flash location(s) must be transferred to the command register locations, where they can be read to the system or changed directly. This is accomplished by sending the set-up command *BlockDataControl( )* (0x61) with data 0x00. Up to 32 bytes of data can be read directly from the *BlockData( )* (0x40...0x5f), externally altered, then rewritten to the *BlockData( )* command space. Alternatively, specific locations can be read, altered, and rewritten if their corresponding offsets are used to index into the *BlockData( )* command space. Finally, the data residing in the command space is transferred to data flash, once the correct checksum for the whole block is written to *BlockDataChecksum( )* (0x60).

Occasionally, a data flash CLASS will be larger than the 32-byte block size. In this case, the *DataFlashBlock( )* command is used to designate which 32-byte block the desired locations reside in. The correct command address is then given by  $0x40 + \text{offset} \text{ modulo } 32$ . For example, to access **Terminate Voltage** in the *Gas Gauging* class, *DataFlashClass( )* is issued 80 (0x50) to set the class. Because the offset is 48, it must reside in the second 32-byte block. Hence, *DataFlashBlock( )* is issued 0x01 to set the block offset, and the offset used to index into the *BlockData( )* memory area is  $0x40 + 48 \text{ modulo } 32 = 0x40 + 16 = 0x40 + 0x10 = 0x50$ .

Reading and writing subclass data are block operations up to 32 bytes in length. If during a write the data length exceeds the maximum block size, then the data is ignored.

None of the data written to memory are bounded by the bq27410, the values are not rejected by the fuel gauge. Writing an incorrect value may result in hardware failure due to firmware program interpretation of the invalid data. The written data is persistent, so a power-on reset does not resolve the fault.

## ACCESS MODES

The bq27410 provides three security modes (FULL ACCESS, UNSEALED, and SEALED) that control data flash access permissions according to [Table 6](#). *Public Access* refers Data flash to those data flash locations, specified in [Table 7](#), that are accessible to the user. *Private Access* refers to reserved data flash locations used by the bq27410 system. Care should be taken to avoid writing to *Private* data flash locations when performing block writes in *Full Access* mode, by following the procedure outlined in *ACCESSING THE DATAFLASH*.

**Table 6. Data Flash Access**

Security Mode	Data Flash	Manufacturer Info
FULL ACCESS	R/W	R/W
UNSEALED	R/W	R/W
SEALED	None	R(A)

Although FULL ACCESS and UNSEALED modes appear identical, only FULL ACCESS mode allows the bq27410 to write access-mode transition keys.

## SEALING/UNSEALING DATA FLASH

The bq27410 implements a key-access scheme to transition between SEALED, UNSEALED, and FULL-ACCESS modes. Each transition requires that a unique set of two keys be sent to the bq27410 via the *Control( )* control command. The keys must be sent consecutively, with no other data being written to the *Control( )* register in between. Note that to avoid conflict, the keys must be different from the codes presented in the *CNTL DATA* column of [Table 2](#) subcommands.

When in SEALED mode the *[SS]* bit of CONTROL\_STATUS is set, but when the UNSEAL keys are correctly received by the bq27410, the *[SS]* bit is cleared. When the full-access keys are correctly received then the CONTROL\_STATUS *[FAS]* bit is cleared.

Both the sets of keys for each level are 2 bytes each in length and are stored in data flash. The UNSEAL key (stored at **Unseal Key 0** and **Unseal Key 1**) and the FULL-ACCESS key (stored at **Full Access Key 0** and **Full Access Key 1**) can only be updated when in FULL-ACCESS mode. The order of the bytes entered through the *Control( )* command is the reverse of what is read from the part. For example, if the 1st and 2nd word of the **UnSeal Key 0** returns 0x1234 and 0x5678, then *Control( )* should supply 0x3412 and 0x7856 to unseal the part.

## DATA FLASH SUMMARY

Table 7 summarizes the data flash locations available to the user, including their default, minimum, and maximum values.

**Table 7. Data Flash Summary**

Class	SubClass ID	SubClass	Offset	Name	Data Type	Min	Max	Default	Unit (EVSW Unit)
Configuration	34	Charge	2	Charging Voltage	I2	0	4600	4200	mV
Configuration	36	Charge Termination	0	Taper Current	I2	0	1000	100	mA
Configuration	36	Charge Termination	4	Taper Voltage	I2	0	1000	100	mV
Configuration	48	Data	13	Cycle Count	U2	0	65535	0	(num)
Configuration	48	Data	19	Design Capacity	I2	0	32767	1340	mAh
Configuration	48	Data	21	Design Energy	I2	0	32767	4960	mWh
Configuration	64	Registers	0	Op Config	H1	0x0	0xff	0x19	(flg)
Configuration	64	Registers	3	SOCI Delta	U1	0	100	1	hex
Configuration	68	Power	2	Sleep Current	I2	0	100	10	mA
Configuration	68	Power	11	Hibernate I	U2	0	700	8	mA
Configuration	68	Power	13	Hibernate V	U2	2400	3000	2550	mV
System Data	57	Manufacturer Info	0-31	Block A 0-31	H1	0x0	0xff	0x0	-
Gas Gauging	80	IT Cfg	45	Terminate Voltage	I2	2800	3700	3000	mV
Ra Table	91	R_a0	0	Cell0 R_a flag	H2	0x0000	0xffff	0x0055	-
Ra Table	91	R_a0	2-31	Cell0 R_a 0-14	I2	183	183	102	num
Ra Table	93	R_a0x	0	xCell0 R_a flag	H2	0x0000	0xffff	0x00ff	-
Ra Table	93	R_a0x	2-31	xCell0 R_a 0-14	I2	183	183	102	num
Calibration	104	Data	0	CC Gain	F4	1.00E-01	4.00E+01	0.4768	num (2 <sup>~</sup> 10Ω)
Calibration	104	Data	4	CC Delta	F4	2.98E+04	1.19E+06	567744.568	num (2 <sup>~</sup> 10Ω)
Calibration	104	Data	8	CC Offset	U2	0	65535	-1200	num (mV)
Calibration	104	Data	10	Board Offset	I1	-128	127	0	num (uV)
Calibration	104	Data	11	Int Temp Offset	I1	-128	127	0	num (°C)
Calibration	104	Data	13	Pack V Offset	I1	-128	127	0	num (mV)
Security	112	Codes	0	Sealed to Unsealed	H4	0x0	0xffffffff	x36720414	-
Security	112	Codes	4	Unsealed to Full	H4	0x0	0xffffffff	0xffffffff	-
Security	112	Codes	24	FactRestore Key	H4	0x0	0xffffffff	0x00000000	-

## FUNCTIONAL DESCRIPTION

### FUEL GAUGING

The bq27410 is an easy to configure fuel gauge that measures the cell voltage, temperature, and current to determine battery SOC. The bq27410 monitors charge and discharge activity by sensing the voltage across a small-value resistor (5 mΩ to 20 mΩ typ.) between the SRP and SRN pins and in series with the cell. By integrating charge passing through the battery, the battery's SOC is adjusted during battery charge or discharge.

The total battery capacity is found by comparing states of charge before and after applying the load with the amount of charge passed. When an application load is applied, the impedance of the cell is measured by comparing the OCV obtained from a predefined function for present SOC with the measured voltage under load. Measurements of OCV and charge integration determine chemical state of charge and chemical capacity (Qmax). The initial Qmax values are taken from the **Design Capacity**. The bq27410 acquires and updates the

battery-impedance profile during normal battery usage. It uses this profile, along with SOC and the Qmax value, to determine *FullChargeCapacity*( ) and *StateOfCharge*( ), specifically for the present load and temperature. *FullChargeCapacity*( ) is reported as capacity available from a fully charged battery under the present load and temperature until *Voltage*( ) reaches the **Term Voltage**. *NominalAvailableCapacity*( ) and *FullAvailableCapacity*( ) are the uncompensated (no or light load) versions of *RemainingCapacity*( ) and *FullChargeCapacity*( ) respectively.

## FUEL GAUGING Ra TABLE

Cell0 / xCell0 R\_a flag:

The Ra flag indicates the validity of the table data associated with this flag and whether this particular table is enabled or disabled. The flag should be read only during normal operation.

Each status has one byte and it has the following options:

- 0x00: This means that the table has had a resistance update in the past, but not currently enabled for the cell.
- 0xff: This means that the values in this table are default values. These table resistance values have never been updated, and is not the currently enabled value for the cell.
- 0x55: This means that this table is enabled for the cell and is in use by the algorithm.

Cell0/xCell0 R\_a 0-14:

The **Ra Table** class has 2 resistance tables, each with 15 values. Each of these values is unitless and is only a representation of resistance for the associated grid point. When a FACTORY\_RESTORE subcommand is provided, the **Ra Table** is restored to default resistance to factory condition.

## FUEL GAUGING CONFIGURATIONS

The bq27410 features easy to configure data flash to speed-up fuel gauging design. Users are required to configure **Design Capacity**, **Termination Voltage**, and **Operation Configuration** (see [The Operation Configuration Register](#) section for details) to achieve optimal performance. The Impedance Track™ algorithm uses these parameters with it's built-in parameters to achieve accurate battery fuel gauging.

Several built-in parameters are used in the Impedance Track™ algorithm to identify different modes of battery:

- Charging : **Chg Current Threshold** (default = **DesignCapacity** /13.3 ),
- Discharging: **Dsg Current Threshold** (default = **DesignCapacity** /16.7 )
- Relax: **Quit Current Threshold** (default = **DesignCapacity** /25.0 )

To achieve accurate fuel gauging, the bq27410 uses Constant Power Model for fuel gauging. This model uses the average discharge power from the beginning of the discharge cycle until present time to compute load-compensated capacity such as *RemainingCapacity*( ) and *FullChargeCapacity*( ) in the Impedance Track™ algorithm.

## DETAILED PIN DESCRIPTIONS

### The Operation Configuration Register

Two bq27410 pins are configured via the **Operation Configuration** data flash register, as indicated in [Table 8](#). This register is programmed/read via the methods described in [Section Accessing the Data Flash](#).

**Table 8. Operation Configuration Bit Definition**

	bit7	bit6	bit5	bit4	bit3	bit2	bit1	bit0
	RESCAP	RSVD	BATLOWEN	SLEEP	RMFCC	BIE	GPIO_POL	WRTEMP
Default	0	0	0	1	1	0	0	1

RESCAP = No-load rate of compensation is applied to the reserve capacity calculation. True when set. Default is 0.

RSVD = Reserved for future use.

BATLOWEN = If set, the BAT\_LOW function for GPOUT pin is selected. If cleared, the SOC\_INT function is selected for GPOUT. Default is 0

SLEEP = The fuel gauge can enter sleep, if operating conditions allow. True when set. Default is 1.

RMFCC = RM is updated with the value from FCC, on valid charge termination. True when set. Default is 1.

BIE = Battery Insertion Enable. If set, the battery insertion is detection via BIN pin input. If cleared, the detection relies on the host to issue BAT\_INSERT subcommand to indicate battery presence in the system. Default is 0.

GPIO\_POL = GPOUT pin is active-high if set or active-low if cleared. Default is 0.

WRTEMP = Enables the host to write *Temperature()* if set. If cleared, the internal temperature sensor is used for *Temperature()*. Default is 1.

### GPOUT Pin

The GPOUT Pin is a multiplex pin and the polarity of the pin output can be selected via the *[GPIO\_POL]* bit of the **Operation Configuration**. The function is defined by *[BATLOWEN]*. If set, the Battery Low Indicator (BAT\_LOW) function for GPOUT pin is selected. If cleared, the SOC interrupt (SOC\_INT) function is selected for GPOUT.

When the BAT\_LOW function is activated, the signaling on the multiplexed pin follows the status of the *[SOC1]* bit in the *Flags()* register. The bq27410 has two flags accessed by the *Flags()* function that warns when the battery's SOC has fallen to critical levels. When *RemainingCapacity()* falls below the first capacity threshold, specified in **SOC1 Set Threshold** (factory default = 150mAh), the *[SOC1]* (*State of Charge Initial*) flag is set. The flag is cleared once *RemainingCapacity()* rises above **SOC1 Set Threshold** (factory default = 175mAh). The bq27410's GPOUT pin automatically reflects the status of the *[SOC1]* flag when **OpConfig[BATLOWEN]=0**.

When *RemainingCapacity()* falls below the second capacity threshold, **SOCF Set Threshold** (factory default = 75mAh), the *[SOCF]* (*State of Charge Final*) flag is set, serving as a final discharge warning. Similarly, when *RemainingCapacity()* rises above **SOCF Clear Threshold** (factory default = 100mAh) and the *[SOCF]* flag has already been set, the *[SOCF]* flag is cleared.

When the SOC\_INT function is activated, the GPOUT pin generates 1ms pulse width under various conditions as described in [Table 9](#).

**Table 9. SOC\_INT Function Definition**

	Enable Condition	Pulse Width	Description
SOCI_Delta	SOCI_Delta ≠ 0	1ms	During charge, when the <i>StateOfCharge()</i> reaches greater than or equal to (≥) the defined SOC_INT intervals. The intervals are defined as 100% and 100% – n × SOCI_Delta.  During discharge, when the <i>StateOfCharge()</i> reaches less than (<) the defined SOC_INT intervals. The intervals are defined as 0% and 100% – n × SOCI_Delta.  n: Integer value starting from 0.  For <b>SOCI_Delta</b> = 10%, the SOC_INT intervals are 0%, 10%, 20%, ..... 90%, and 100%.
State Change	SOCI_Delta ≠ 0	1ms	When there is a state change including charging, discharging, and relaxation.
Battery Removal	[BIE] bit is set in OpConfig	1ms	When battery removal is detected by BIN pin.

## Battery Detection (BIN)

The host is responsible for battery detection by setting the [BAT\_DET] bit to trigger INITIALIZATION mode. The function of *OpConfig[BIE]* bit is described in [Table 10](#). When battery insertion is detected and INITIALIZATION mode is completed, the bq27410 runs in NORMAL mode to start Impedance Track™ fuel gauging. When battery insertion is not detected, fuel gauging is stopped.

**Table 10. Battery Detection**

<i>OpConfig[BIE]</i>	Battery Insertion Requirement	Battery Removal Requirement
1	(1) Host drives BIN pin from logic high to low to signal battery insertion. or (2) A weak pull-up resistor can be used (between BIN and VCC pin). When battery pack with pull-down is connected, it can generate a logic low to signal battery insertion.	(1) Host drives BIN pin from logic low to high to signal battery removal. or (2) When battery pack with pull-down is removed, the weak pull-up resistor can generate a logic high to signal battery removal.
0	Host sends BAT_INSERT subcommand to signal battery insertion.	Host sends BAT_REMOVE subcommand to signal battery removal.

## TEMPERATURE MEASUREMENT

The bq27410 measures temperature using an on-chip temperature sensor. Alternatively if [WRTEMP] = 1, the host sends temperature data to the gauge with the initial default setting at 25°C. Regardless of [WRTEMP] setting, the fuel gauge uses temperature data in *Temperature()* command for fuel gauging.

### Over-Temperature Indication: Charge

If during charging, *Temperature()* reaches the threshold of **OT Chg** (default = 55°C) for a period of **OT Chg Time** (default = 2 seconds) and *AverageCurrent()* > *Chg Current Threshold* (default = **DesignCapacity** / 13.3), then the [OTC] bit of *Flags()* is set. When *Temperature()* falls to **OT Chg Recovery** (default = 50°C), the [OTC] of *Flags()* is reset.

### Over-Temperature Indication: Discharge

If during discharging, *Temperature()* reaches the threshold of **OT Dsg** (default = 60°C) for a period of **OT Dsg Time** (default = 2 seconds) , and *AverageCurrent()* ≤ **-Dsg Current Threshold** (default = **DesignCapacity** /16.7) , then the [OTD] bit of *Flags()* is set. When *Temperature()* falls to **OT Dsg Recovery** (default = 55°C), the [OTD] bit of *Flags()* is reset.

## DETECTING CHARGE TERMINATION

The bq27410 detects charge termination when (1) during 2 consecutive periods of **Current Taper Window** (default = 40 seconds), the *AverageCurrent()* is < **Taper Current** (default = 100 mA), (2) during the same periods, the accumulated change in capacity > 0.25mAh/ / **Current Taper Window** (default = 40 seconds), and (3) *Voltage()* > (**Charging Voltage** – 100mV) where **Charging Voltage** = 4200mV by default. When this occurs, the [CHG] bit of *Flags()* is cleared. Also, if the [RMFCC] bit of **Operation Configuration** is set, and *RemainingCapacity()* is set equal to *FullChargeCapacity()*.

### Charge Inhibit

The bq27410 can indicate when battery temperature has fallen below or risen above predefined thresholds **Charge Inhibit Temp Low** (default = 0°C) or **Charge Inhibit Temp High** (default = 45°C), respectively. In this mode, the [CHG\_INH] of *Flags()* is made high to indicate this condition, and is returned to its low state, once battery temperature returns to the range [**Charge Temp Low, Charge Temp High**] (default = [5°C,40°C]).

## POWER MODES

The bq27410 has different power modes: INITIALIZATION, NORMAL, SLEEP, FULLSLEEP and HIBERNATE. Following Power On Reset (POR), the fuel gauge begins INITIALIZATION. In NORMAL mode, the bq27410 is fully powered and can execute any allowable task. In SLEEP mode both low frequency and high frequency oscillators are active. Although the SLEEP has higher current consumption than the FULLSLEEP mode, it is also a reduced power mode. In FULLSLEEP mode the fuel gauge turns off the high frequency oscillator and exists in a reduced-power state, periodically taking measurements and performing calculations. In HIBERNATE mode, the fuel gauge is in a very low power state, but can be woken up by communication or certain I/O activity.

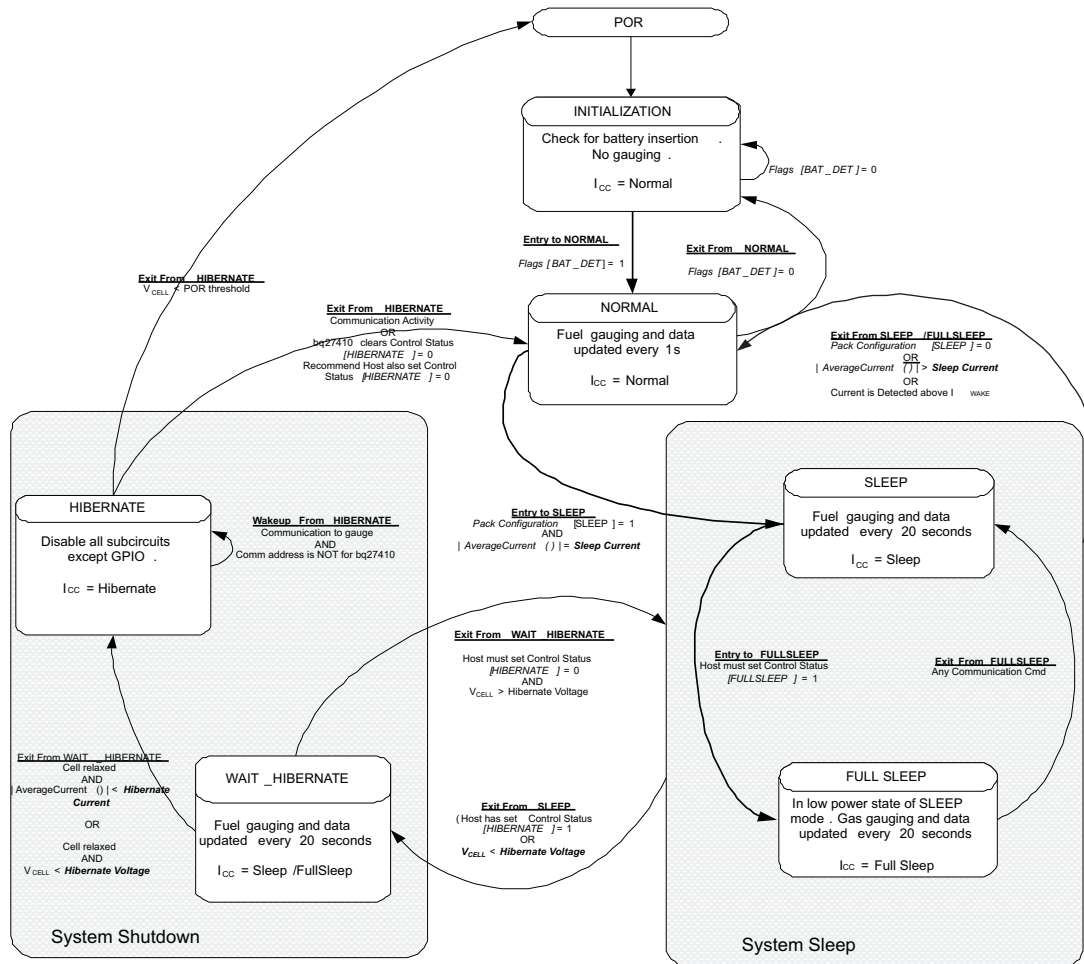

Figure 2. Power Mode Diagram

### INITIALIZATION Mode

Following Power On Reset (POR), the fuel gauge begins INITIALIZATION mode where essential data is initialized and will remain in INITIALIZATION mode as halted-CPU state when an adapter, or other power source is present to power the bq27410 (and system), yet no battery has been detected. Until battery insertion is detected, the fuel gauge cannot transition to other power mode. When battery insertion is detected, a series of initialization activities begin including an OCV measurement. In addition CONTROL\_STATUS[QMAXU] and [RESU] bits are cleared to allow fast learning of Qmax and impedance.

Some commands, issued by a system processor, can be processed while the bq27410 is halted in this mode. The gauge will wake up to process the command, and then return to the halted state awaiting battery insertion. The current consumption of INITIALIZATION mode is similar to NORMAL mode.

## NORMAL Mode

The fuel gauge is in NORMAL mode when not in any other power mode. During this mode, *AverageCurrent()*, *Voltage()* and *Temperature()* measurements are taken, and the interface data set is updated. Decisions to change states are also made. This mode is exited by activating a different power mode.

Because the gauge consumes the most power in NORMAL mode, the Impedance Track™ algorithm minimizes the time the fuel gauge remains in this mode.

## SLEEP Mode

SLEEP mode is entered automatically if the feature is enabled (**Operation Configuration [SLEEP]** = 1) and *AverageCurrent()* is below the programmable level **Sleep Current** (default = 10mA). Once entry into SLEEP mode has been qualified, but prior to entering it, the bq27410 performs an ADC autocalibration to minimize offset.

During SLEEP mode, the bq27410 periodically takes data measurements and updates its data set. However, a majority of its time is spent in an idle condition.

The bq27410 exits SLEEP if any entry condition is broken, specifically when: *AverageCurrent()* rises above **Sleep Current** (default = 10mA).

## FULLSLEEP Mode

FULLSLEEP mode is entered automatically if the feature is enabled by setting the [FULLSLEEP] bit in the Control Status register when the BQ27410 is in SLEEP mode. The gauge exits the FULLSLEEP and returns to SLEEP mode when there is communication to the gauge. The bq27410 can also exit FULLSLEEP and returns to NORMAL if any SLEEP mode entry condition is broken, specifically when *AverageCurrent()* rises above Sleep Current is detected. Therefore, the execution of SET\_FULLSLEEP sets [FULLSLEEP] bit, but EVSW might still display the bit clear. The FULLSLEEP mode can be verified by measuring the current consumption of the gauge. In this mode, the high frequency oscillator is turned off. The power consumption is further reduced in this mode compared to the SLEEP mode.

During FULLSLEEP mode, the BQ27410 periodically takes data measurements and updates its data set. However, a majority of its time is spent in an idle condition.

While in FULLSLEEP mode, the fuel gauge can suspend serial communications as much as 4ms by holding the communication line(s) low. This delay is necessary to correctly process host communication, since the fuel gauge processor is mostly halted in FULLSLEEP mode.

## HIBERNATE Mode

HIBERNATE mode could be used when the system equipment needs to enter a very low-power state, and minimal gauge power consumption is required. This mode is ideal when a system equipment is set to its own HIBERNATE, SHUTDOWN, or OFF modes.

Before the fuel gauge can enter HIBERNATE mode, the system must set the [HIBERNATE] bit of the CONTROL\_STATUS register. The gauge waits to enter HIBERNATE mode until it has taken a valid OCV measurement and the magnitude of the average cell current has fallen below **Hibernate Current**. The gauge can also enter HIBERNATE mode if the cell voltage falls below **Hibernate Voltage**. The gauge will remain in HIBERNATE mode until the system issues a direct I<sup>2</sup>C command to the gauge. I<sup>2</sup>C Communication that is not directed to the gauge will not wake the gauge (or at least for very long).

It is the system's responsibility to wake the bq27410 after it has gone into HIBERNATE mode and prevents a charger from charging the battery before the [OCVTAKEN] bit is set which signals an OCV reading is taken. After waking, the gauge can proceed with the initialization of the battery information.



COMMUNICATIONS (continued)

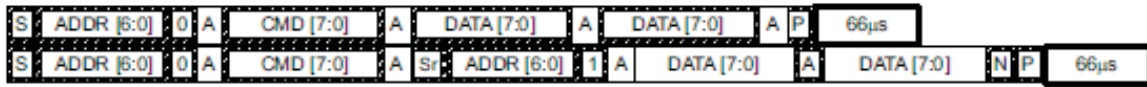

Waiting time between control subcommand and reading results

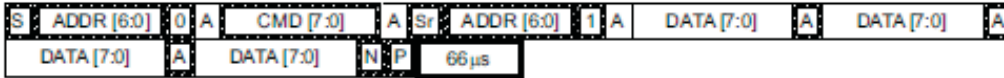

Waiting time between continuous reading results

### REFERENCE SCHEMATIC

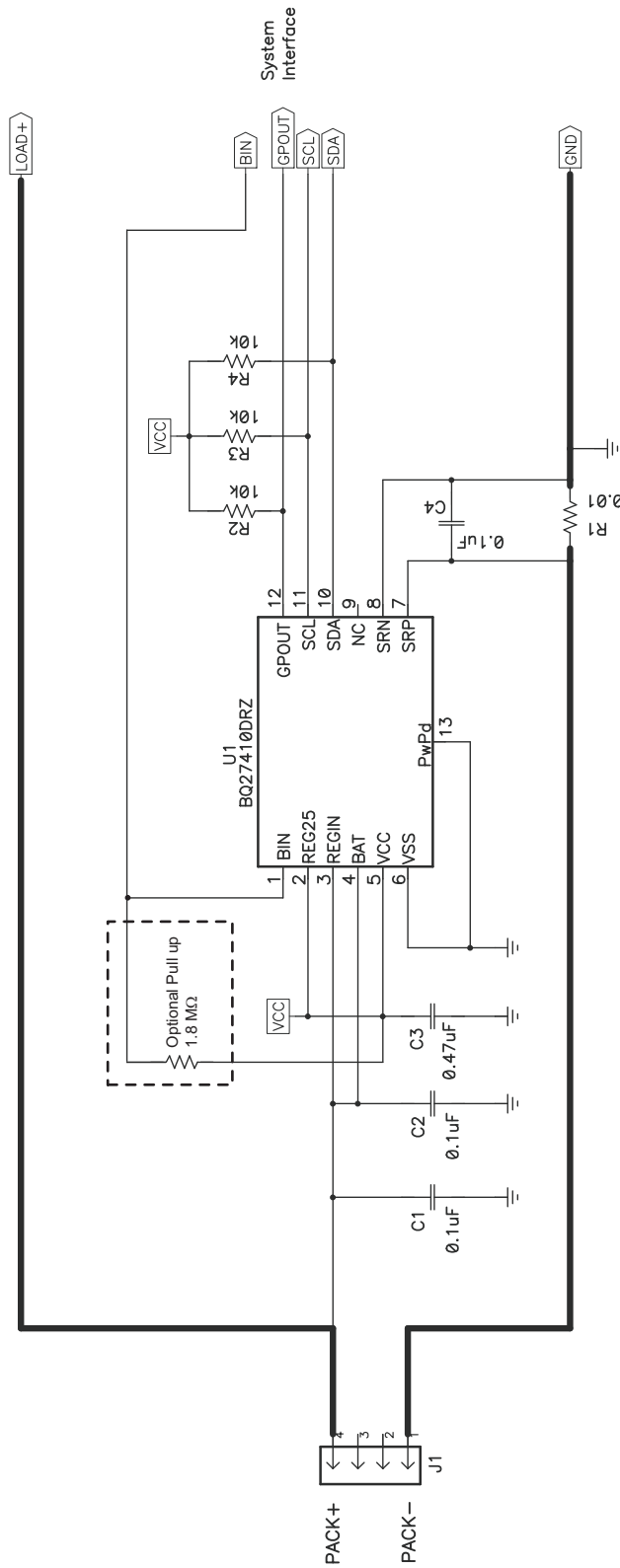

Note: The capacitor for coulomb counter input should be placed as close as possible to gas gauge IC. Connection to sense resistor must be of Kelvin connection type.

Note: PACK+ and PACK- pins may require ESD protection depending on system level requirements. Contact factory for assistance if needed.

**PACKAGING INFORMATION**

Orderable Device	Status (1)	Package Type	Package Drawing	Pins	Package Qty	Eco Plan (2)	Lead/Ball Finish (6)	MSL Peak Temp (3)	Op Temp (°C)	Device Marking (4/5)	Samples
BQ27410DRZR-G1	NRND	SON	DRZ	12	2500	Green (RoHS & no Sb/Br)	CU NIPDAU	Level-2-260C-1 YEAR	-40 to 85	BQ 7410	
BQ27410DRZT-G1	NRND	SON	DRZ	12	250	Green (RoHS & no Sb/Br)	CU NIPDAU	Level-2-260C-1 YEAR	-40 to 85	BQ 7410	

(1) The marketing status values are defined as follows:

**ACTIVE:** Product device recommended for new designs.

**LIFEBUY:** TI has announced that the device will be discontinued, and a lifetime-buy period is in effect.

**NRND:** Not recommended for new designs. Device is in production to support existing customers, but TI does not recommend using this part in a new design.

**PREVIEW:** Device has been announced but is not in production. Samples may or may not be available.

**OBSOLETE:** TI has discontinued the production of the device.

(2) **RoHS:** TI defines "RoHS" to mean semiconductor products that are compliant with the current EU RoHS requirements for all 10 RoHS substances, including the requirement that RoHS substance do not exceed 0.1% by weight in homogeneous materials. Where designed to be soldered at high temperatures, "RoHS" products are suitable for use in specified lead-free processes. TI may reference these types of products as "Pb-Free".

**RoHS Exempt:** TI defines "RoHS Exempt" to mean products that contain lead but are compliant with EU RoHS pursuant to a specific EU RoHS exemption.

**Green:** TI defines "Green" to mean the content of Chlorine (Cl) and Bromine (Br) based flame retardants meet JS709B low halogen requirements of <=1000ppm threshold. Antimony trioxide based flame retardants must also meet the <=1000ppm threshold requirement.

(3) MSL, Peak Temp. - The Moisture Sensitivity Level rating according to the JEDEC industry standard classifications, and peak solder temperature.

(4) There may be additional marking, which relates to the logo, the lot trace code information, or the environmental category on the device.

(5) Multiple Device Markings will be inside parentheses. Only one Device Marking contained in parentheses and separated by a "~" will appear on a device. If a line is indented then it is a continuation of the previous line and the two combined represent the entire Device Marking for that device.

(6) Lead/Ball Finish - Orderable Devices may have multiple material finish options. Finish options are separated by a vertical ruled line. Lead/Ball Finish values may wrap to two lines if the finish value exceeds the maximum column width.

**Important Information and Disclaimer:**The information provided on this page represents TI's knowledge and belief as of the date that it is provided. TI bases its knowledge and belief on information provided by third parties, and makes no representation or warranty as to the accuracy of such information. Efforts are underway to better integrate information from third parties. TI has taken and continues to take reasonable steps to provide representative and accurate information but may not have conducted destructive testing or chemical analysis on incoming materials and chemicals. TI and TI suppliers consider certain information to be proprietary, and thus CAS numbers and other limited information may not be available for release.

In no event shall TI's liability arising out of such information exceed the total purchase price of the TI part(s) at issue in this document sold by TI to Customer on an annual basis.



## TAPE AND REEL INFORMATION



### QUADRANT ASSIGNMENTS FOR PIN 1 ORIENTATION IN TAPE



\*All dimensions are nominal

Device	Package Type	Package Drawing	Pins	SPQ	Reel Diameter (mm)	Reel Width W1 (mm)	A0 (mm)	B0 (mm)	K0 (mm)	P1 (mm)	W (mm)	Pin1 Quadrant
BQ27410DRZR-G1	SON	DRZ	12	2500	330.0	12.4	2.8	4.3	1.2	4.0	12.0	Q2
BQ27410DRZR-G1	SON	DRZ	12	2500	330.0	12.4	2.8	4.3	1.2	4.0	12.0	Q2
BQ27410DRZT-G1	SON	DRZ	12	250	330.0	12.4	2.8	4.3	1.2	4.0	12.0	Q2

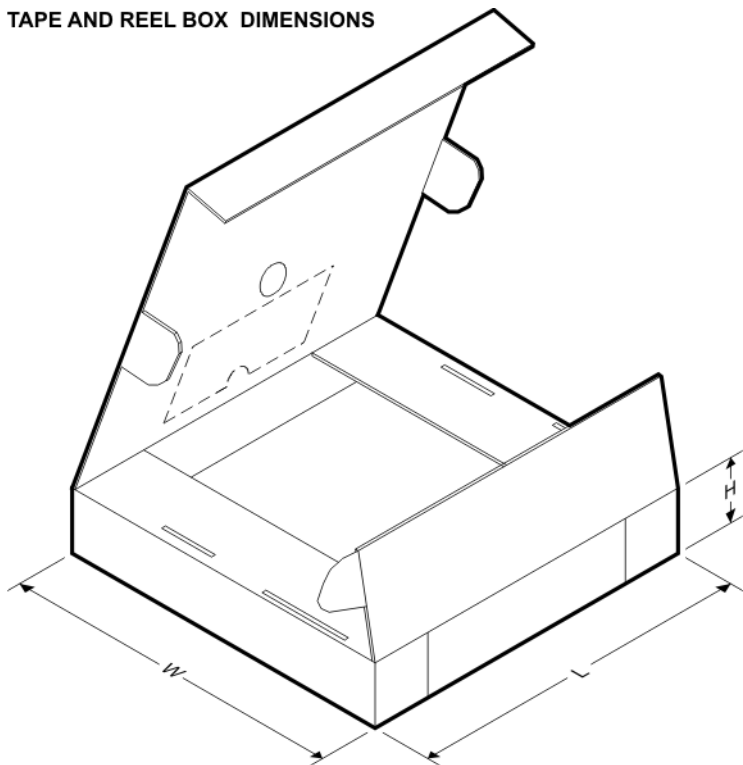
**TAPE AND REEL BOX DIMENSIONS**

\*All dimensions are nominal

Device	Package Type	Package Drawing	Pins	SPQ	Length (mm)	Width (mm)	Height (mm)
BQ27410DRZR-G1	SON	DRZ	12	2500	338.1	338.1	20.6
BQ27410DRZR-G1	SON	DRZ	12	2500	367.0	367.0	35.0
BQ27410DRZT-G1	SON	DRZ	12	250	367.0	367.0	38.0



DRZ (R-PDSO-N12)

PLASTIC SMALL OUTLINE NO-LEAD

**THERMAL INFORMATION**

This package incorporates an exposed thermal pad that is designed to be attached directly to an external heatsink. The thermal pad must be soldered directly to the printed circuit board (PCB). After soldering, the PCB can be used as a heatsink. In addition, through the use of thermal vias, the thermal pad can be attached directly to the appropriate copper plane shown in the electrical schematic for the device, or alternatively, can be attached to a special heatsink structure designed into the PCB. This design optimizes the heat transfer from the integrated circuit (IC).

For information on the Quad Flatpack No-Lead (QFN) package and its advantages, refer to Application Report, QFN/SON PCB Attachment, Texas Instruments Literature No. SLUA271. This document is available at [www.ti.com](http://www.ti.com).

The exposed thermal pad dimensions for this package are shown in the following illustration.

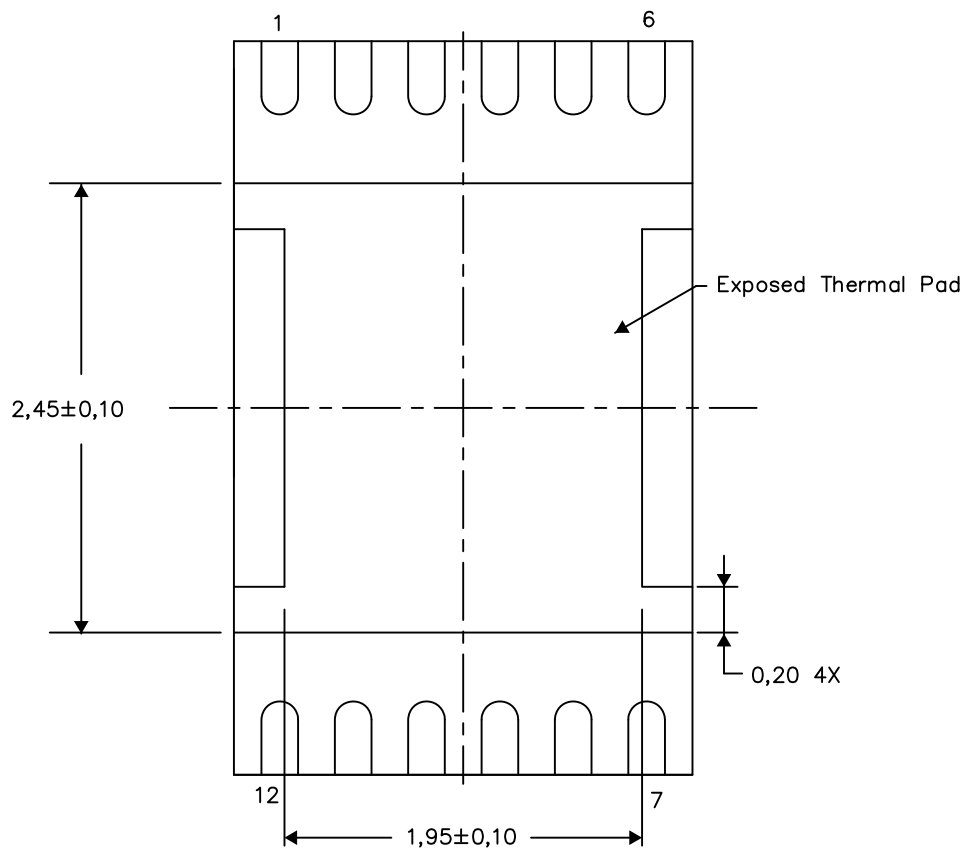

Bottom View  
Exposed Thermal Pad Dimensions

4208114/F 10/14

NOTE: All linear dimensions are in millimeters

DRZ (S-PDSO-N12)

PLASTIC SMALL OUTLINE NO-LEAD

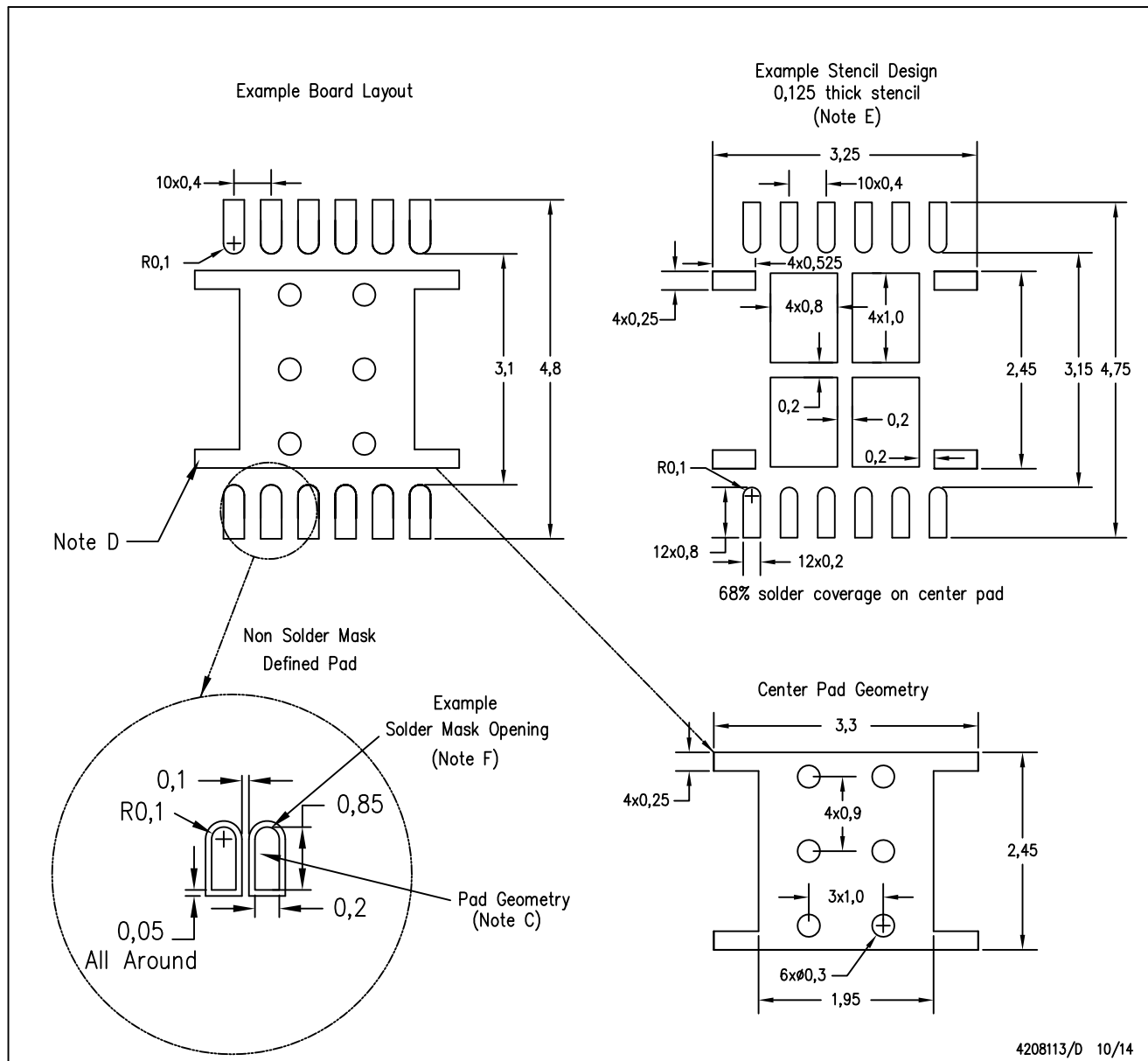

4208113/D 10/14

- NOTES:
- All linear dimensions are in millimeters.
  - This drawing is subject to change without notice.
  - Publication IPC-7351 is recommended for alternate designs.
  - This package is designed to be soldered to a thermal pad on the board. Refer to Application Note, Quad Flat-Pack Packages, Texas Instruments Literature No. SCBA017, SLUA271, and also the Product Data Sheets for specific thermal information, via requirements, and recommended board layout. These documents are available at [www.ti.com](http://www.ti.com) <<http://www.ti.com>>.
  - Laser cutting apertures with trapezoidal walls and also rounding corners will offer better paste release. Customers should contact their board assembly site for stencil design recommendations. Refer to IPC 7525 for stencil design considerations.
  - Customers should contact their board fabrication site for minimum solder mask web tolerances between signal pads.

## IMPORTANT NOTICE AND DISCLAIMER

TI PROVIDES TECHNICAL AND RELIABILITY DATA (INCLUDING DATASHEETS), DESIGN RESOURCES (INCLUDING REFERENCE DESIGNS), APPLICATION OR OTHER DESIGN ADVICE, WEB TOOLS, SAFETY INFORMATION, AND OTHER RESOURCES "AS IS" AND WITH ALL FAULTS, AND DISCLAIMS ALL WARRANTIES, EXPRESS AND IMPLIED, INCLUDING WITHOUT LIMITATION ANY IMPLIED WARRANTIES OF MERCHANTABILITY, FITNESS FOR A PARTICULAR PURPOSE OR NON-INFRINGEMENT OF THIRD PARTY INTELLECTUAL PROPERTY RIGHTS.



These resources are intended for skilled developers designing with TI products. You are solely responsible for (1) selecting the appropriate TI products for your application, (2) designing, validating and testing your application, and (3) ensuring your application meets applicable standards, and any other safety, security, or other requirements. These resources are subject to change without notice. TI grants you permission to use these resources only for development of an application that uses the TI products described in the resource. Other reproduction and display of these resources is prohibited. No license is granted to any other TI intellectual property right or to any third party intellectual property right. TI disclaims responsibility for, and you will fully indemnify TI and its representatives against, any claims, damages, costs, losses, and liabilities arising out of your use of these resources.

TI's products are provided subject to TI's Terms of Sale ([www.ti.com/legal/termsofsale.html](http://www.ti.com/legal/termsofsale.html)) or other applicable terms available either on [ti.com](http://ti.com) or provided in conjunction with such TI products. TI's provision of these resources does not expand or otherwise alter TI's applicable warranties or warranty disclaimers for TI products.

Mailing Address: Texas Instruments, Post Office Box 655303, Dallas, Texas 75265  
Copyright © 2018, Texas Instruments Incorporated

## Looking for pricing, stock, or lifecycle information?

Click below to explore more details on WIN SOURCE:

-  [View BQ27410DRZR-G1 on WIN SOURCE](#)
-  [Texas Instruments](#) Information

## Optimize Your Supply Chain with WIN SOURCE Solutions

-  Global Sourcing Solution
-  Obsolete Management
-  Cost Control Management
-  Shortage Management
-  Alternative Solution
-  Excess Inventory Management