



**THE DATASHEET OF
BQ24735RGRT**



Table of Contents

1 Features	1	9.4 Device Functional Modes	18
2 Applications	1	9.5 Programming	19
3 Description	1	9.6 Register Maps	22
4 Revision History	2	10 Application and Implementation	27
5 Description (continued)	3	10.1 Application Information	27
6 Pin Configuration and Functions	3	10.2 Typical Application	27
7 Specifications	4	10.3 System Examples	33
7.1 Absolute Maximum Ratings	4	11 Power Supply Recommendations	35
7.2 ESD Ratings	5	12 Layout	35
7.3 Recommended Operating Conditions	5	12.1 Layout Guidelines	35
7.4 Thermal Information	5	12.2 Layout Example	37
7.5 Electrical Characteristics	5	13 Device and Documentation Support	38
7.6 Timing Requirements	9	13.1 Device Support	38
7.7 Typical Characteristics	10	13.2 Documentation Support	38
8 Parameter Measurement Information	12	13.3 Trademarks	38
9 Detailed Description	13	13.4 Electrostatic Discharge Caution	38
9.1 Overview	13	13.5 Glossary	38
9.2 Functional Block Diagram	14	14 Mechanical, Packaging, and Orderable Information	38
9.3 Feature Description	15		

4 Revision History

NOTE: Page numbers for previous revisions may differ from page numbers in the current version.

Changes from Revision A (January 2013) to Revision B	Page
• Added ESD Ratings table, Overview, Feature Description section, Device Functional Modes, Application and Implementation section, Power Supply Recommendations section, Layout section, Device and Documentation Support section, and Mechanical, Packaging, and Orderable Information section	1
• Changed the format to the new template	1
• Deleted ", and is available in a 20-pin, 3.5x3.5 mm ² QFN package" from last paragraph in Description section. Added the Device Information table on page 1.	3
• Added LODRV, HIDRV, and PHASE (2% duty cycle) to the Absolute Maximum Ratings table	4

Changes from Original (September 2011) to Revision A	Page
• Added V _(ESD) specs	5

5 Description (continued)

The bq24735 device uses an internal input current register or an external ILIM pin to throttle down PWM modulation to reduce the charge current. The bq24735 device charges 1-, 2-, 3-, or 4-series Li+ cells.

6 Pin Configuration and Functions

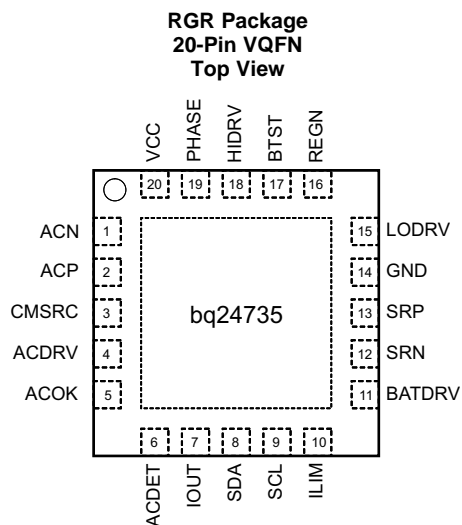

Pin Functions

PIN		DESCRIPTION
NAME	NO.	
ACDET	6	Adapter detection input. Program adapter valid input threshold by connecting a resistor divider from adapter input to ACDET pin to GND pin. When ACDET pin is above 0.6 V and VCC is above UVLO, REGN LDO is present, ACOK comparator and IOU are both active.
ACDRV	4	Charge pump output to drive both adapter input N-channel MOSFET (ACFET) and reverse blocking N-channel MOSFET (RBFET). ACDRV voltage is 6 V above CMSRC when voltage on ACDET pin is between 2.4 V and 3.15 V, voltage on VCC pin is above UVLO and voltage on VCC pin is 275 mV above voltage on SRN pin so that ACFET and RBFET can be turned on to power the system by AC adapter. Place a 4-kΩ resistor from ACDRV to the gate of ACFET and RBFET limits the inrush current on ACDRV pin.
ACOK	5	AC adapter detection open-drain output. It is pulled HIGH to external pullup supply rail by external pullup resistor when voltage on ACDET pin is between 2.4 V and 3.15 V, and voltage on VCC is above UVLO and voltage on VCC pin is 275 mV above voltage on SRN pin, indicating a valid adapter is present to start charge. If any one of the above conditions cannot be met, it is pulled LOW to GND by internal MOSFET. Connect a 10-kΩ pullup resistor from ACOK to the pullup supply rail.
ACN	1	Input current-sense resistor negative input. Place an optional 0.1-μF ceramic capacitor from ACN to GND for common-mode filtering. Place a 0.1-μF ceramic capacitor from ACN to ACP to provide differential-mode filtering.
ACP	2	Input current-sense resistor positive input. Place a 0.1-μF ceramic capacitor from ACP to GND for common-mode filtering. Place a 0.1-μF ceramic capacitor from ACN to ACP to provide differential-mode filtering.
BATDRV	11	Charge pump output to drive battery-to-system N-channel MOSFET (BATFET). BATDRV voltage is 6 V above SRN to turn on BATFET to power the system from battery. BATDRV voltage is SRN voltage to turn off BATFET to power system from AC adapter. Place a 4-kΩ resistor from BATDRV to the gate of BATFET limits the inrush current on BATDRV pin.
BTST	17	High-side power MOSFET driver power supply. Connect a 0.047-μF capacitor from BTST to PHASE, and a bootstrap Schottky diode from REGN to BTST.
CMSRC	3	ACDRV charge pump source input. Place a 4-kΩ resistor from CMSRC to the common source of ACFET (Q1) and RBFET (Q2) limits the inrush current on CMSRC pin.
GND	14	IC ground. On PCB layout, connect to analog ground plane, and only connect to power ground plane through the power pad underneath IC.
HIDRV	18	High-side power MOSFET driver output. Connect to the high-side N-channel MOSFET gate.

Pin Functions (continued)

PIN		DESCRIPTION
NAME	NO.	
ILIM	10	Charge current limit input. Program ILIM voltage by connecting a resistor divider from system reference 3.3-V rail to ILIM pin to GND pin. The lower of ILIM voltage or DAC limit voltage sets charge current regulation limit. To disable the control on ILIM, set ILIM above 1.6 V. Once voltage on ILIM pin falls below 75 mV, charge (buck mode) or discharge (boost mode) is disabled. Charge and discharge is enabled when ILIM pin rises above 105 mV.
IOUT	7	Buffered adapter or charge current output, selectable with SMBus command ChargeOption(). IOUT voltage is 20 times the differential voltage across sense resistor. Place a 100-pF or less ceramic decoupling capacitor from IOUT pin to GND.
LODRV	15	Low-side power MOSFET driver output. Connect to low-side N-channel MOSFET gate.
PHASE	19	High-side power MOSFET driver source. Connect to the source of the high-side N-channel MOSFET.
PowerPAD™	—	Exposed pad beneath the IC. Analog ground and power ground star-connected only at the PowerPad plane. Always solder PowerPad to the board, and have vias on the PowerPad plane connecting to analog ground and power ground planes. It also serves as a thermal pad to dissipate the heat.
REGN	16	Linear regulator output. REGN is the output of the 6-V linear regulator supplied from VCC. The LDO is active when voltage on ACDET pin is above 0.6 V and voltage on VCC is above UVLO. Connect a 1-μF ceramic capacitor from REGN to GND.
SCL	9	SMBus open-drain clock input. Connect to SMBus clock line from the host controller or smart battery. Connect a 10-kΩ pullup resistor according to SMBus specifications.
SDA	8	SMBus open-drain data I/O. Connect to SMBus data line from the host controller or smart battery. Connect a 10-kΩ pullup resistor according to SMBus specifications.
SRN	12	Charge current-sense resistor negative input. SRN pin is for battery voltage sensing as well. Connect SRN pin to a 7.5-Ω resistor first, then, from another resistor terminal, connect a 0.1-μF ceramic capacitor to GND for common-mode filtering, and connect to current-sensing resistor. Connect a 0.1-μF ceramic capacitor between current-sensing resistor to provide differential-mode filtering. See Application and Implementation about negative output voltage protection for hard shorts on battery-to-ground or battery-reverse connection by adding small resistor.
SRP	13	Charge current-sense resistor positive input. Connect SRP pin to a 10-Ω resistor first, then from another resistor terminal, connect to current-sensing resistor. Connect a 0.1-μF ceramic capacitor between current-sensing resistor to provide differential-mode filtering. See Application and Implementation about negative output voltage protection for hard shorts on battery to ground or battery reverse connection by adding small resistor.
VCC	20	Input supply, diode OR from adapter or battery voltage. Use 10-Ω resistor and 1-μF capacitor to ground as low-pass filter to limit inrush current.

7 Specifications

7.1 Absolute Maximum Ratings

over operating free-air temperature range (unless otherwise noted) ⁽¹⁾

		MIN	MAX	UNIT
Voltage	SRN, SRP, ACN, ACP, CMSRC, VCC	-0.3	30	V
	PHASE	-2	30	
	ACDET, SDA, SCL, LODRV, REGN, IOUT, ILIM, ACOK	-0.3	7	
	BTST, HIDRV, ACDRV, BATDRV	-0.3	36	
	LODRV (2% duty cycle)	-4	7	
	HIDVR (2% duty cycle)	-4	36	
	PHASE (2% duty cycle)	-4	30	
Maximum difference voltage	SRP-SRN, ACP-ACN	-0.5	0.5	
Junction temperature, T _J		-40	155	°C
Storage temperature, T _{stg}		-55	155	°C

(1) Stresses beyond those listed under *Absolute Maximum Ratings* may cause permanent damage to the device. These are stress ratings only, which do not imply functional operation of the device at these or any other conditions beyond those indicated under *Recommended Operating Conditions*. Exposure to absolute-maximum-rated conditions for extended periods may affect device reliability.

7.2 ESD Ratings

		VALUE	UNIT
$V_{(ESD)}$	Electrostatic discharge	Human body model (HBM), per ANSI/ESDA/JEDEC JS-001 ⁽¹⁾	±2000
		Charged device model (CDM), per JEDEC specification JESD22-C101 ⁽²⁾	±500

(1) JEDEC document JEP155 states that 500-V HBM allows safe manufacturing with a standard ESD control process.

(2) JEDEC document JEP157 states that 250-V CDM allows safe manufacturing with a standard ESD control process.

7.3 Recommended Operating Conditions

over operating free-air temperature range (unless otherwise noted)

		MIN	NOM	MAX	UNIT
Voltage	SRN, SRP, ACN, ACP, CMSRC, VCC	0		24	V
	PHASE	-2		24	
	ACDET, SDA, SCL, LODRV, REGN, IOUT, ILIM, ACOK	0		6.5	
	BTST, HIDRV, ACDRV, BATDRV	0		30	
Maximum difference voltage	SRP-SRN, ACP-ACN	-0.2		0.2	V
Junction temperature, T_J		0		125	°C

7.4 Thermal Information

THERMAL METRIC ⁽¹⁾		bq24735			UNIT
		RGR [VQFN]			
		20 PINS			
$R_{\theta JA}$	Junction-to-ambient thermal resistance	46.8			°C/W
$R_{\theta JC(top)}$	Junction-to-case (top) thermal resistance	56.9			°C/W
$R_{\theta JB}$	Junction-to-board thermal resistance	46.6			°C/W
Ψ_{JT}	Junction-to-top characterization parameter	0.6			°C/W
Ψ_{JB}	Junction-to-board characterization parameter	15.3			°C/W
$R_{\theta JC(bot)}$	Junction-to-case (bottom) thermal resistance	4.4			°C/W

(1) For more information about traditional and new thermal metrics, see the *Semiconductor and IC Package Thermal Metrics* application report, [SPRA953](#).

7.5 Electrical Characteristics

$4.5\text{ V} \leq V_{VCC} \leq 24\text{ V}$, $0^\circ\text{C} \leq T_J \leq 125^\circ\text{C}$, typical values are at $T_A = 25^\circ\text{C}$, with respect to GND (unless otherwise noted)

PARAMETER	TEST CONDITIONS	MIN	TYP	MAX	UNIT	
OPERATING CONDITIONS						
V_{VCC_OP}	VCC Input voltage operating range	4.5		24	V	
CHARGE VOLTAGE REGULATION						
$V_{BAT_REG_RNG}$	Battery voltage range	1.024		19.2	V	
$V_{BAT_REG_ACC}$	Charge voltage regulation accuracy	ChargeVoltage() = 0x41A0H	16.716	16.8	16.884	V
			-0.5%		0.5%	
	Charge voltage regulation accuracy	ChargeVoltage() = 0x3130H	12.529	12.592	12.655	V
			-0.5%		0.5%	
	Charge voltage regulation accuracy	ChargeVoltage() = 0x20D0H	8.35	8.4	8.45	V
			-0.6%		0.6%	
	Charge voltage regulation accuracy	ChargeVoltage() = 0x1060H	4.163	4.192	4.221	V
			-0.7%		0.7%	
CHARGE CURRENT REGULATION						
$V_{IREG_CHG_RNG}$	Charge current regulation differential voltage range	$V_{IREG_CHG} = V_{SRP} - V_{SRN}$	0	81.28	mV	

Electrical Characteristics (continued)

4.5 V ≤ V_{VCC} ≤ 24 V, 0°C ≤ T_J ≤ 125°C, typical values are at T_A = 25°C, with respect to GND (unless otherwise noted)

PARAMETER		TEST CONDITIONS	MIN	TYP	MAX	UNIT
I _{CHRG_REG_ACC}	Charge current regulation accuracy 10-mΩ current-sensing resistor	ChargeCurrent() = 0x1000H	3973	4096	4219	mA
			-3%		3%	
		ChargeCurrent() = 0x0800H	1946	2048	2150	mA
			-5%		5%	
		ChargeCurrent() = 0x0200H	410	512	614	mA
			-20%		20%	
ChargeCurrent() = 0x0100H	172	256	340	mA		
	-33%		33%			
ChargeCurrent() = 0x0080H	64	128	192	mA		
	-50%		50%			
INPUT CURRENT REGULATION						
V _{IREG_DPM_RNG}	Input current regulation differential voltage range	V _{IREG_DPM} = V _{ACP} - V _{ACN}	0		80.64	mV
I _{DPM_REG_ACC}	Input current regulation accuracy 10-mΩ current-sensing resistor	InputCurrent() = 0x1000H	3973	4096	4219	mA
			-3%		3%	
		InputCurrent() = 0x0800H	1946	2048	2150	mA
			-5%		5%	
		InputCurrent() = 0x0400H	870	1024	1178	mA
			-15%		15%	
InputCurrent() = 0x0200H	384	512	640	mA		
	-25%		25%			
INPUT CURRENT OR CHARGE CURRENT-SENSE AMPLIFIER						
V _{ACP/N_OP}	Input common-mode range	Voltage on ACP/ACN	4.5		24	V
V _{SRP/N_OP}	Output common-mode range	Voltage on SRP/SRN	0		19.2	V
V _{IOUT}	IOUT output voltage range		0		3.3	V
I _{IOUT}	IOUT output current		0		1	mA
A _{IOUT}	Current-sense amplifier gain	V _{(IOUT)/V_(SRP-SRN)} or V _(ACP-ACN)		20		V/V
V _{IOUT_ACC}	Current-sense output accuracy	V _(SRP-SRN) or V _(ACP-ACN) = 40.96 mV	-2%		2%	
		V _(SRP-SRN) or V _(ACP-ACN) = 20.48 mV	-4%		4%	
		V _(SRP-SRN) or V _(ACP-ACN) = 10.24 mV	-15%		15%	
		V _(SRP-SRN) or V _(ACP-ACN) = 5.12 mV	-20%		20%	
		V _(SRP-SRN) or V _(ACP-ACN) = 2.56 mV	-33%		33%	
		V _(SRP-SRN) or V _(ACP-ACN) = 1.28 mV	-50%		50%	
C _{IOUT_MAX}	Maximum output load capacitance	For stability with 0- to 1-mA load			100	pF
REGN REGULATOR						
V _{REGN_REG}	REGN regulator voltage	V _{VCC} > 6.5 V, V _{ACDET} > 0.6 V (0-45 mA load)	5.5	6	6.5	V
I _{REGN_LIM}	REGN current limit	V _{REGN} = 0 V, V _{VCC} > UVLO charge enabled and not in TSHUT	50	75		mA
		V _{REGN} = 0 V, V _{VCC} > UVLO charge disabled or in TSHUT	7	14		mA
C _{REGN}	REGN output capacitor required for stability	I _{LOAD} = 100 μA to 50 mA		1		μF
INPUT UNDERVOLTAGE LOCKOUT COMPARATOR (UVLO)						
UVLO	Undervoltage rising threshold	V _{VCC} rising	3.5	3.75	4	V
	Undervoltage hysteresis, falling	V _{VCC} falling		340		mV
FAST DPM COMPARATOR (FAST_DPM)						
V _{FAST_DPM}	Fast DPM comparator stop charging rising threshold with respect to input current limit, voltage across input sense resistor rising edge		103%	107%	111%	
QUIESCENT CURRENT						
I _{BAT_BATFET_OFF}	Battery BATFET OFF STATE Current, BATFET off, I _{SRP} + I _{SRN} + I _{PHASE} + I _{ACP} + I _{ACN}	V _{BAT} = 16.8 V, V _{CC} disconnect from battery, BATFET charge pump off, BATFET turns off, T _J = 0 to 85°C			5	μA

Electrical Characteristics (continued)

4.5 V ≤ V_{VCC} ≤ 24 V, 0°C ≤ T_J ≤ 125°C, typical values are at T_A = 25°C, with respect to GND (unless otherwise noted)

PARAMETER		TEST CONDITIONS	MIN	TYP	MAX	UNIT
I _{BAT_BATFET_ON}	Battery BATFET ON STATE Current, BATFET on, I _{SRP} + I _{SRN} + I _{PHASE} + I _{VCC} + I _{ACP} + I _{ACN}	V _{BAT} = 16.8 V, VCC connect from battery, BATFET charge pump on, BATFET turns on, T _J = 0 to 85°C			25	μA
I _{STANDBY}	Standby quiescent current, I _{VCC} + I _{ACP} + I _{ACN}	V _{VCC} > UVLO, V _{ACDET} > 0.6 V, charge disabled, T _J = 0 to 85°C		0.65	0.8	mA
I _{AC_NOSW}	Adapter bias current during charge, I _{VCC} + I _{ACP} + I _{ACN}	V _{VCC} > UVLO, 2.4 V < V _{ACDET} < 3.15 V, charge enabled, no switching, T _J = 0 to 85°C		1.5	3	mA
I _{AC_SW}	Adapter bias current during charge, I _{VCC} + I _{ACP} + I _{ACN}	V _{VCC} > UVLO, 2.4 V < V _{ACDET} < 3.15 V, charge enabled, switching, MOSFET Sis412DN		10		mA
ACOK COMPARATOR						
V _{ACOK_RISE}	ACOK rising threshold	V _{VCC} > UVLO, V _{ACDET} rising	2.376	2.4	2.424	V
V _{ACOK_FALL_HYS}	ACOK falling hysteresis	V _{VCC} > UVLO, V _{ACDET} falling	35	55	75	mV
V _{WAKEUP_RISE}	WAKEUP detect rising threshold	V _{VCC} > UVLO, V _{ACDET} rising		0.57	0.8	V
V _{WAKEUP_FALL}	WAKEUP detect falling threshold	V _{VCC} > UVLO, V _{ACDET} falling	0.3	0.51		V
VCC to SRN COMPARATOR (VCC_SRN)						
V _{VCC-SRN_FALL}	VCC-SRN falling threshold	V _{VCC} falling toward V _{SRN}	70	125	200	mV
V _{VCC-SRN_RHYS}	VCC-SRN rising hysteresis	V _{VCC} rising above V _{SRN}	100	150	200	mV
ACN to SRN COMPARATOR (ACN_SRN)						
V _{ACN-SRN_FALL}	ACN to BAT falling threshold	V _{ACN} falling toward V _{SRN}	120	200	280	mV
V _{ACN-SRN_RHYS}	ACN to BAT rising hysteresis	V _{ACN} rising above V _{SRN}	40	80	120	mV
HIGH-SIDE IFAULT COMPARATOR (IFAULT_HI)⁽¹⁾						
V _{IFAULT_HI_RISE}	ACP to PHASE rising threshold	ChargeOption() bit [8] = 1 (Default)	450	750	1200	mV
		ChargeOption() bit [8] = 0 Disable function				
LOW-SIDE IFAULT COMPARATOR (IFAULT_LOW)⁽¹⁾						
V _{IFAULT_LOW_RISE}	PHASE to GND rising threshold	ChargeOption() bit [7] = 0 (Default)	70	135	220	mV
		ChargeOption() bit [7] = 1	140	230	340	
INPUT OVERVOLTAGE COMPARATOR (ACOV)						
V _{ACOV}	ACDET overvoltage rising threshold	V _{ACDET} rising	3.05	3.15	3.25	V
V _{ACOV_HYS}	ACDET overvoltage falling hysteresis	V _{ACDET} falling	50	75	100	mV
INPUT OVERCURRENT COMPARATOR (ACOC)⁽¹⁾						
V _{ACOC}	Adapter overcurrent rising threshold with respect to input current limit, voltage across input sense resistor rising edge	ChargeOption() bit [1] = 1 (Default)	300%	333%	366%	
		ChargeOption() bit [1] = 0 Disable function				
V _{ACOC_min}	Min ACOC threshold clamp voltage	ChargeOption() bit [1] = 1 (333%), InputCurrent () = 0x0400H (10.24 mV)	40	45	50	mV
V _{ACOC_max}	Max ACOC threshold clamp voltage	ChargeOption() bit [1] = 1 (333%), InputCurrent () = 0x1F80H (80.64 mV)	135	150	165	mV
BAT OVERVOLTAGE COMPARATOR (BAT_OVP)						
V _{OVP_RISE}	Overvoltage rising threshold as percentage of V _{BAT_REG}	V _{SRN} rising	103%	104%	106%	
V _{OVP_FALL}	Overvoltage falling threshold as percentage of V _{BAT_REG}	V _{SRN} falling		102%		
CHARGE OVERCURRENT COMPARATOR (CHG_OCP)						
V _{OCP_RISE}	Charge overcurrent rising threshold, measure voltage drop across current-sensing resistor	ChargeCurrent() = 0x0xxxH	54	60	66	mV
		ChargeCurrent() = 0x1000H – 0x17C0H	80	90	100	
		ChargeCurrent() = 0x1800 H– 0x1FC0H	110	120	130	
CHARGE UNDERCURRENT COMPARATOR (CHG_UCP)						
V _{UCP_FALL}	Charge undercurrent falling threshold	V _{SRP} falling toward V _{SRN}	1	5	9	mV
LIGHT LOAD COMPARATOR (LIGHT_LOAD)						
V _{LL_FALL}	Light load falling threshold	Measure the voltage drop across current-sensing resistor		1.25		mV
V _{LL_RISE_HYST}	Light load rising hysteresis			1.25		mV

(1) User can adjust threshold through SMBus ChargeOption() REG0x12.

Electrical Characteristics (continued)

4.5 V ≤ V_{VCC} ≤ 24 V, 0°C ≤ T_J ≤ 125°C, typical values are at T_A = 25°C, with respect to GND (unless otherwise noted)

PARAMETER		TEST CONDITIONS	MIN	TYP	MAX	UNIT
BATTERY DEPLETION COMPARATOR (BAT_DEPL) [1]						
V _{BATDEPL_FALL}	Battery depletion falling threshold, percentage of voltage regulation limit, V _{SRN} falling	ChargeOption() bit [12:11] = 00	55.53%	59.19%	63.5%	
		ChargeOption() bit [12:11] = 01	58.68%	62.65%	67.5%	
		ChargeOption() bit [12:11] = 10	62.17%	66.55%	71.5%	
		ChargeOption() bit [12:11] = 11 (Default)	66.06%	70.97%	77%	
V _{BATDEPL_RHYST}	Battery depletion rising hysteresis, V _{SRN} rising	ChargeOption() bit [12:11] = 00	225	305	400	mV
		ChargeOption() bit [12:11] = 01	240	325	430	
		ChargeOption() bit [12:11] = 10	255	345	450	
		ChargeOption() bit [12:11] = 11 (Default)	280	370	490	
t _{BATDEPL_RDEG}	Battery depletion rising deglitch (specified by design)	Delay to turn off ACFET and turn on BATFET during LEARN cycle		600		ms
BATTERY LOWV COMPARATOR (BAT_LOWV)						
V _{BATLV_FALL}	Battery LOWV falling threshold	V _{SRN} falling	2.4	2.5	2.6	V
V _{BATLV_RHYST}	Battery LOWV rising hysteresis	V _{SRN} rising		200		mV
I _{BATLV}	Battery LOWV charge current limit	10-mΩ current-sensing resistor		0.5		A
THERMAL SHUTDOWN COMPARATOR (TSHUT)						
T _{SHUT}	Thermal shutdown rising temperature	Temperature rising		155		°C
T _{SHUT_HYS}	Thermal shutdown hysteresis, falling	Temperature falling		20		°C
ILIM COMPARATOR						
V _{ILIM_FALL}	ILIM as CE falling threshold	V _{ILIM} falling	60	75	90	mV
V _{ILIM_RISE}	ILIM as CE rising threshold	V _{ILIM} rising	90	105	120	mV
LOGIC INPUT (SDA, SCL)						
V _{IN_LO}	Input low threshold				0.8	V
V _{IN_HI}	Input high threshold		2.1			V
I _{IN_LEAK}	Input bias current	V = 7 V	-1		1	μA
LOGIC OUTPUT OPEN DRAIN (ACOK, SDA)						
V _{OUT_LO}	Output saturation voltage	5-mA drain current			500	mV
I _{OUT_LEAK}	Leakage current	V = 7 V	-1		1	μA
ANALOG INPUT (ACDET, ILIM)						
I _{IN_LEAK}	Input bias current	V = 7 V	-1		1	μA
PWM OSCILLATOR						
F _{SW}	PWM switching frequency	ChargeOption() bit [9] = 0 (Default)	600	750	900	kHz
F _{SW+}	PWM increase frequency	ChargeOption() bit [10:9] = 11	665	885	1100	kHz
F _{SW-}	PWM decrease frequency	ChargeOption() bit [10:9] = 01	465	615	765	kHz
BATFET GATE DRIVER (BATDRV)						
I _{BATFET}	BATDRV charge pump current limit		40	60		μA
V _{BATFET}	Gate drive voltage on BATFET	V _{BATDRV} - V _{SRN} when V _{SRN} > UVLO	5.5	6.1	6.5	V
R _{BATDRV_LOAD}	Minimum load resistance between BATDRV and SRN		500			kΩ
R _{BATDRV_OFF}	BATDRV turnoff resistance	I = 30 μA	5	6.2	7.4	kΩ
ACFET GATE DRIVER (ACDRV)						
I _{ACFET}	ACDRV charge pump current limit		40	60		μA
V _{ACFET}	Gate drive voltage on ACFET	V _{ACDRV} - V _{CMSRC} when V _{VCC} > UVLO	5.5	6.1	6.5	V
R _{ACDRV_LOAD}	Minimum load resistance between ACDRV and CMSRC		500			kΩ
R _{ACDRV_OFF}	ACDRV turnoff resistance	I = 30 μA	5	6.2	7.4	kΩ
V _{ACFET_LOW}	ACDRV turnoff when V _{gs} voltage is low (specified by design)			5.9		V
PWM HIGH-SIDE DRIVER (HIDRV)						
R _{DS_HI_ON}	High-side driver turnon resistance	V _{BTST} - V _{PH} = 5.5 V, I = 10 mA		6	10	Ω
R _{DS_HI_OFF}	High-side driver turnoff resistance	V _{BTST} - V _{PH} = 5.5 V, I = 10 mA		0.65	1.3	Ω

Electrical Characteristics (continued)

4.5 V ≤ V_{VCC} ≤ 24 V, 0°C ≤ T_J ≤ 125°C, typical values are at T_A = 25°C, with respect to GND (unless otherwise noted)

PARAMETER		TEST CONDITIONS	MIN	TYP	MAX	UNIT
V _{BTST_REFRESH}	Bootstrap refresh comparator threshold voltage	V _{BTST} – V _{PH} when low-side refresh pulse is requested	3.85	4.3	4.7	V
PWM LOW-SIDE DRIVER (LODRV)						
R _{DS_LO_ON}	Low-side driver turnon resistance	V _{REGN} = 6 V, I = 10 mA		7.5	12	Ω
R _{DS_LO_OFF}	Low-side driver turnoff resistance	V _{REGN} = 6 V, I = 10 mA		0.9	1.4	Ω
INTERNAL SOFT START						
I _{STEP}	Soft start current step	In CCM mode 10-mΩ current-sensing resistor		64		mA

7.6 Timing Requirements

			MIN	TYP	MAX	UNIT
ACOK COMPARATOR						
V _{ACOK_RISE_DEG}	ACOK rising deglitch (specified by design)	V _{VCC} > UVLO, V _{ACDET} rising above 2.4 V, First time OR ChargeOption() bit [15] = 0	100	150	200	ms
		V _{VCC} > UVLO, V _{ACDET} rising above 2.4 V, (NOT First time) AND ChargeOption() bit [15] = 1 (Default)	0.9	1.3	1.7	s
INPUT OVERCURRENT COMPARATOR (ACOC)⁽¹⁾						
t _{ACOC_DEG}	ACOC deglitch time (specified by design)	Voltage across input sense resistor rising to disable charge	2.3	4.2	6.6	ms
BATTERY DEPLETION COMPARATOR (BAT_DEPL) [1]						
t _{BATDEPL_RDEG}	Battery depletion rising deglitch (specified by design)	Delay to turn off ACFET and turn on BATFET during LEARN cycle		600		ms
PWM DRIVER TIMING						
t _{LOW_HIGH}	Driver dead time from low side to high side			20		ns
t _{HIGH_LOW}	Driver dead time from high side to low side			20		ns
INTERNAL SOFT START						
t _{STEP}	Soft start current step time			240		μs
SMBus TIMING CHARACTERISTICS						
t _R	SCLK/SDATA rise time				1	μs
t _F	SCLK/SDATA fall time				300	ns
t _{W(H)}	SCLK pulse width high		4		50	μs
t _{W(L)}	SCLK Pulse Width Low		4.7			μs
t _{SU(STA)}	Setup time for START condition		4.7			μs
t _{H(STA)}	START condition hold time after which first clock pulse is generated		4			μs
t _{SU(DAT)}	Data setup time		250			ns
t _{H(DAT)}	Data hold time		300			ns
t _{SU(STOP)}	Setup time for STOP condition		4			μs
t _(BUF)	Bus free time between START and STOP condition		4.7			μs
F _{S(CL)}	Clock Frequency		10		100	kHz
HOST COMMUNICATION FAILURE						
t _{timeout}	SMBus bus release time-out ⁽²⁾		25		35	ms
t _{BOOT}	Deglitch for watchdog reset signal		10			ms
t _{WDI}	Watchdog time-out period, ChargeOption() bit [14:13] = 01 ⁽³⁾		35	44	53	s
	Watchdog time-out period, ChargeOption() bit [14:13] = 10 ⁽³⁾		70	88	105	s
	Watchdog time-out period, ChargeOption() bit [14:13] = 11 ⁽³⁾ (Default)		140	175	210	s

- (1) User can adjust threshold through SMBus ChargeOption() REG0x12.
- (2) Devices participating in a transfer will time out when any clock low exceeds the 25-ms minimum time-out period. Devices that have detected a time-out condition must reset the communication no later than the 35-ms maximum time-out period. Both a master and a slave must adhere to the maximum value specified, as it incorporates the cumulative stretch limit for both a master (10 ms) and a slave (25 ms).
- (3) User can adjust threshold through SMBus ChargeOption() REG0x12.

7.7 Typical Characteristics

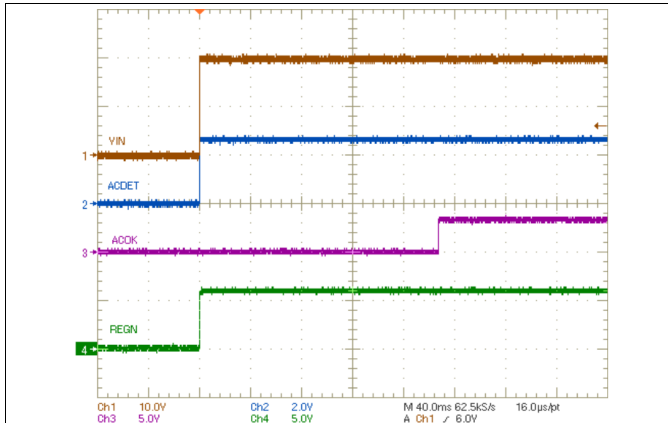

Figure 1. VCC, ACDET, REGN and ACOK Power Up

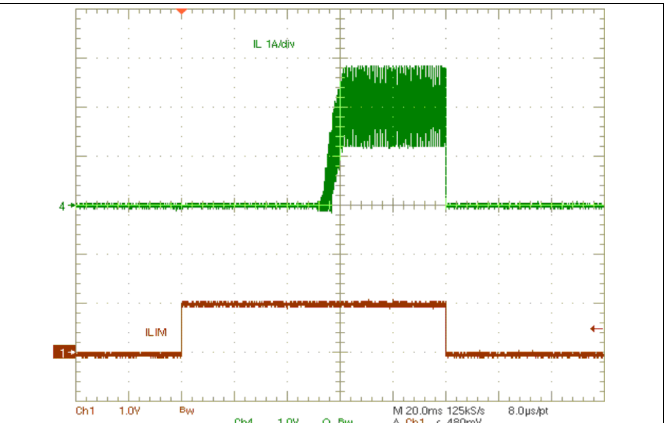

Figure 2. Charge Enable by ILIM

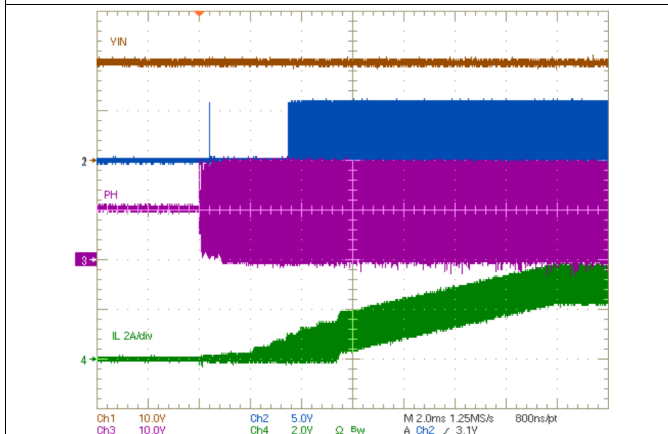

Figure 3. Current Soft-Start

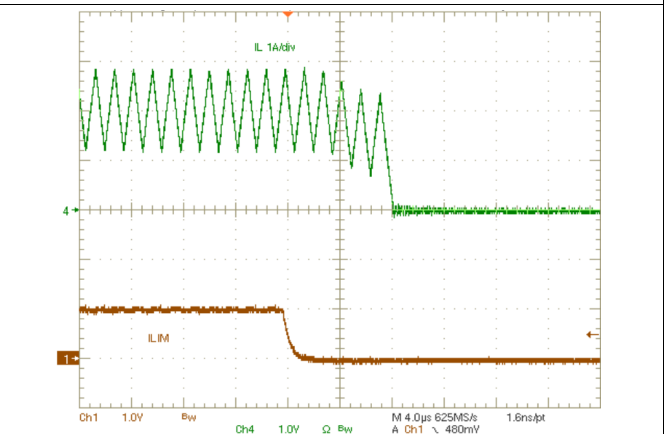
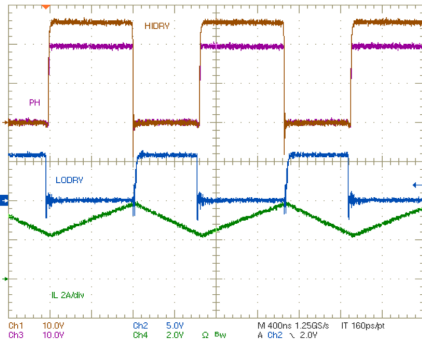

Figure 4. Charge Disable by ILIM

Typical Characteristics (continued)



CH1: PHASE, 10 V/div, CH2: LODRV, 5 V/div,
CH3: HIDRV, 10 V/div
CH4: inductor current, 2 A/div, 400 ns/div

Figure 5. Continuous Conduction Mode Switching Waveforms

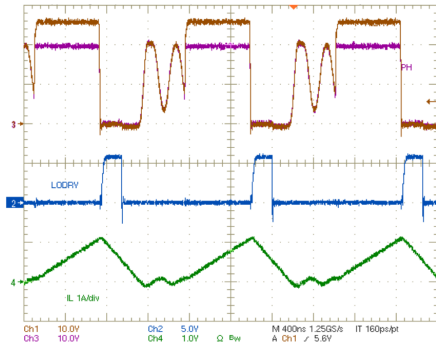

CH1: PHASE, 10 V/div, CH2: LODRV, 5 V/div,
CH3: HIDRV, 10 V/div
CH4: inductor current, 1 A/div, 400 ns/div

Figure 6. Cycle-by-Cycle Synchronous to Nonsynchronous

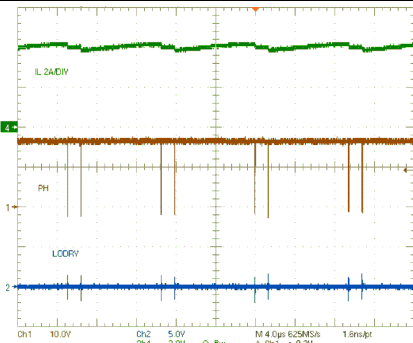

CH1: PHASE, 10 V/div, CH2: LODRV, 5 V/div,
CH4: inductor current, 2 A/div, 4 μs/div

Figure 7. 100% Duty and Refresh Pulse

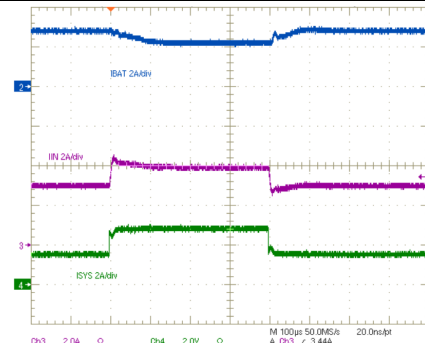

CH2: battery current, 2 A/div, CH3: adapter current, 2 A/div,
CH4: system load current, 2 A/div, 100 μs/div

Figure 8. System Load Transient (Input DPM)

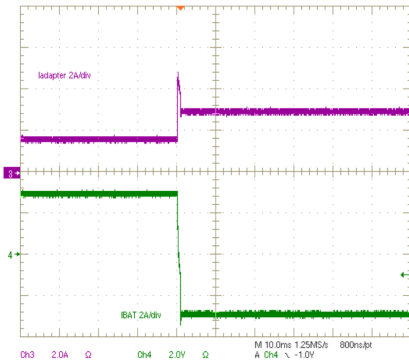

CH3: adapter current, 2 A/div,
CH4: battery current, 2 A/div, 10 ms/div

Figure 9. Buck-to-Boost Mode

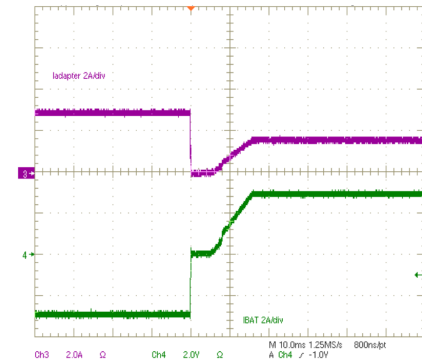

CH3: adapter current, 2 A/div,
CH4: battery current, 2 A/div, 10 ms/div

Figure 10. Boost-to-Buck Mode

8 Parameter Measurement Information

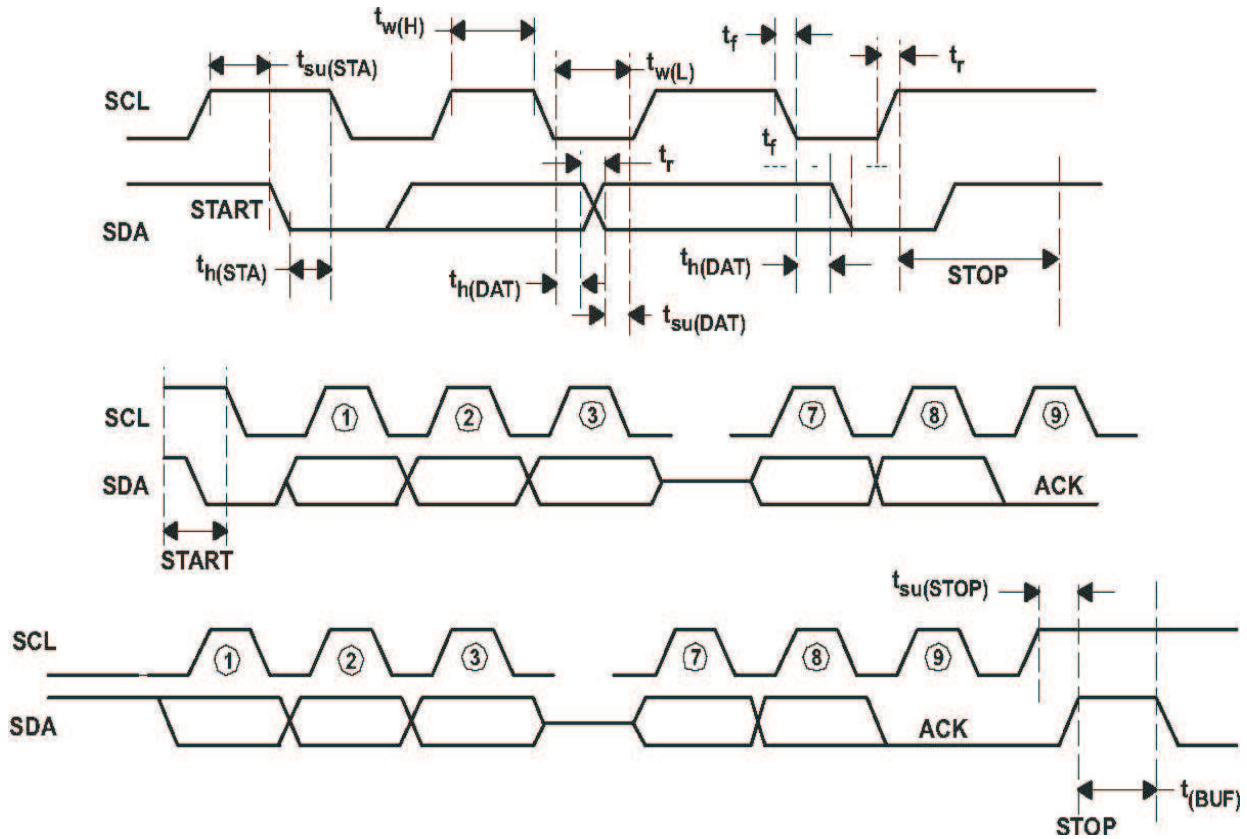

Figure 11. SMBus Communication Timing Waveforms

9 Detailed Description

9.1 Overview

The bq24735 device is a 1- to 4-cell battery charge controller with power selection for space-constrained, multichemistry portable applications such as notebooks and detachable ultrabooks. The device supports wide input range of input sources from 4.5 V to 24 V, and 1- to 4-cell battery for a versatile solution.

The bq24735 device supports automatic system power source selection with separate drivers for N-channel MOSFETS on the adapter side and battery side.

The bq24735 device features Dynamic Power Management (DPM) to limit the input power and avoid AC adapter overloading. During battery charging, as the system power increases, the charging current will reduce to maintain total input current below adapter rating.

The SMBus controls input current, charge current and charge voltage registers with high-resolution, high-accuracy regulation limits.

9.2 Functional Block Diagram

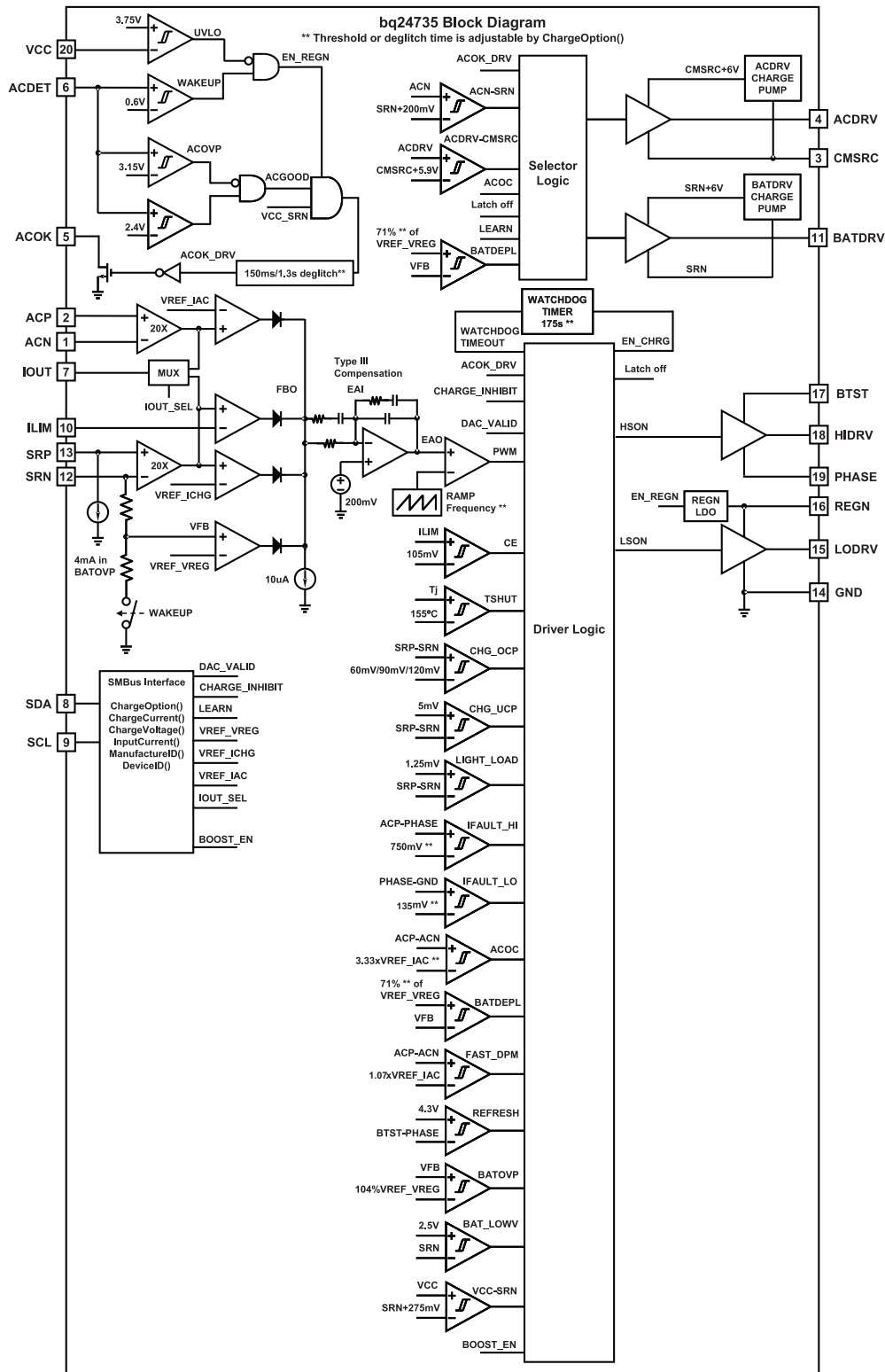

9.3 Feature Description

9.3.1 Adapter Detect and ACOK Output

The bq24735 uses an ACOK comparator to determine the source of power on VCC pin, either from the battery or adapter. An external resistor voltage divider attenuates the adapter voltage before it goes to ACDET. The adapter detect threshold should typically be programmed to a value greater than the maximum battery voltage, but lower than the maximum allowed adapter voltage.

The open-drain ACOK output requires external pullup resistor to system digital rail for a high level. It can be pulled to external rail under the following conditions:

- $V_{VCC} > UVLO$
- $2.4\text{ V} < V_{ACDET} < 3.15\text{ V}$ (not in ACOVP condition, nor in low input voltage condition)
- $V_{VCC} - V_{SRN} > 275\text{ mV}$ (not in sleep mode)

The first time after IC POR always gives 150-ms ACOK rising edge delay no matter what the ChargeOption register value is. Only after the ACDET pin voltage is pulled below 2.4 V (but not below 0.6 V, which resets the IC and forces the next ACOK rising edge deglitch time to be 1.3 s) and the ACFET has been turned off at least one time, the 1.3 s (or 150 ms) delay time is effective for the next time the ACDET pin voltage goes above 2.4 V. To change this option, the VCC pin voltage must above UVLO, and the ACDET pin voltage must be above 0.6 V which enables the IC SMBus communication and sets ChargeOption() bit [15] to 0 which sets the next ACOK rising deglitch time to be 150 ms. The purpose of the default 1.3 s rising edge deglitch time is to turn off the ACFET long enough when the ACDET pin is pulled below 2.4 V by excessive system current, such as overcurrent or short circuit.

9.3.2 Adapter Overvoltage (ACOVp)

When the ACDET pin voltage is higher than 3.15 V, it is considered as adapter overvoltage. ACOK will be pulled low, and charge will be disabled. ACFET will be turned off to disconnect the high voltage adapter to system during ACOVP. BATFET will be turned on if turnon conditions are valid. See [System Power Selection](#) for details.

When ACDET pin voltage falls below 3.15 V and above 2.4 V, it is considered as adapter voltage returns back to normal voltage. ACOK will be pulled high by external pullup resistor. BATFET will be turned off and ACFET and RBFET will be turned on to power the system from adapter. The charge can be resumed if enable charge conditions are valid. See [Enable and Disable Charging](#) for details.

9.3.3 System Power Selection

The bq24735 automatically switches adapter or battery power to system. The battery is connected to system at POR if battery exists. The battery is disconnected from system and the adapter is connected to system after default 150 ms delay (first time, the next time default is 1.3 s and can be changed to 150 ms) if ACOK goes HIGH. An automatic break-before-make logic prevents shoot-through currents when the selectors switch.

The ACDRV drives a pair of common-source (CMSRC) N-channel power MOSFETs (ACFET and RBFET) between adapter and ACP (see [Figure 16](#) for details). The ACFET separates adapter from battery or system, and provides a limited DI/DT when plugging in adapter by controlling the ACFET turnon time. Meanwhile it protects adapter when system or battery is shorted. The RBFET provides negative input voltage protection and battery discharge protection when adapter is shorted to ground, and minimizes system power dissipation with its low $R_{DS(on)}$ compared to a Schottky diode.

When the adapter is not present, ACDRV is pulled to CMSRC to keep ACFET and RBFET off, disconnecting adapter from system. BATDRV stays at $V_{SRN} + 6\text{ V}$ to connect battery to system if all the following conditions are valid:

- $V_{VCC} > UVLO$
- $V_{SRN} > UVLO$
- $V_{ACN} < 200\text{ mV}$ above V_{SRN} (ACN_SRN comparator)

Approximately 150 ms (first time; the next time default is 1.3 s and can be changed to 150 ms) after the adapter is detected (ACDET pin voltage from 2.4 V to 3.15 V), the system power source begins to switch from battery to adapter if all the following conditions are valid:

- Not in LEARN mode or in LEARN mode and V_{SRN} is lower than battery depletion threshold
- ACOK high

Feature Description (continued)

The gate drive voltage on ACFET and RBFET is $V_{CMSRC} + 6\text{ V}$. If the ACFET/RBFET have been turned on for 20 ms, and the voltage across gate and source is still less than 5.9 V, ACFET and RBFET will be turned off. After 1.3-s delay, it resumes turning on ACFET and RBFET. If such a failure is detected seven times within 90 seconds, ACFET/RBFET will be latched off and an adapter removal and system shut down is required to force $ACDET < 0.6\text{ V}$ to reset the IC. After IC reset from latch off, ACFET/RBFET can be turned on again. After 90 seconds, the failure counter will be reset to zero to prevent latch off. With ACFET/RBFET off, charge is disabled.

To turn off ACFET/RBFET, one of the following conditions must be valid:

- In LEARN mode and V_{SRN} is above battery depletion threshold
- ACOK low

To limit the inrush current on ACDRV pin, CMSRC pin and BATDRV pin, a 4-k Ω resistor is recommended on each of the three pins.

To limit the adapter inrush current when ACFET is turned on to power system from adapter, the Cgs and Cgd external capacitor of ACFET must be carefully selected. The larger the Cgs and Cgd capacitance, the slower turnon of ACFET will be and less inrush current of adapter. However, if Cgs or Cgd is too large, the ACDRV-CMSRC voltage may still go low after the 20-ms turnon time window is expired. To make sure ACFET will not be turned on when adapter is hot plugged in, the Cgs value should be 20 times or higher than Cgd. The most cost effective way to reduce adapter inrush current is to minimize system total capacitance.

9.3.4 Automatic Internal Soft-Start Charger Current

Every time the charge is enabled, the charger automatically applies soft start on charge current to avoid any overshoot or stress on the output capacitors or the power converter. The charge current starts at 128 mA, and the step size is 64 mA in CCM mode for a 10-m Ω current sensing resistor. Each step lasts around 240 μs in CCM mode until it reaches the programmed charge current limit. No external components are needed for this function. During DCM mode, the soft start up current step size is larger and each step lasts for longer time period due to the intrinsic slow response of DCM mode.

9.3.5 Converter Operation

The synchronous buck PWM converter uses a fixed-frequency voltage mode control scheme and internal type III compensation network. The LC output filter gives a characteristic resonant frequency:

$$f_o = \frac{1}{2\pi \sqrt{L_o C_o}} \quad (1)$$

The resonant frequency (f_o) is used to determine the compensation to ensure there is sufficient phase margin and gain margin for the target bandwidth. The LC output filter should be selected to give a resonant frequency of 10–20 kHz nominal for the best performance. Suggested component value as charge current of 750-kHz default switching frequency is shown in [Table 1](#).

Ceramic capacitors show a DC-bias effect. This effect reduces the effective capacitance when a DC-bias voltage is applied across a ceramic capacitor, as on the output capacitor of a charger. The effect may lead to a significant capacitance drop, especially for high output voltages and small capacitor packages. See the manufacturer's data sheet about the performance with a DC-bias voltage applied. It may be necessary to choose a higher voltage rating or nominal capacitance value in order to get the required value at the operating point.

Table 1. Suggested Component Value as Charge Current of Default 750-kHz Switching Frequency

Charge Current	2 A	3 A	4 A	6 A	8 A
Output Inductor L_o (μH)	6.8 or 8.2	5.6 or 6.8	3.3 or 4.7	3.3	2.2
Output Capacitor C_o (μF)	20	20	20	30	40
Sense Resistor ($\text{m}\Omega$)	10	10	10	10	10

The bq24735 has three loops of regulation: input current, charge current and charge voltage. The three loops are brought together internally at the error amplifier. The maximum voltage of the three loops appears at the output of the error amplifier EAO. An internal saw-tooth ramp is compared to the internal error control signal EAO (see [Functional Block Diagram](#)) to vary the duty-cycle of the converter. The ramp has offset of 200 mV in order to allow 0% duty-cycle.

When the battery charge voltage approaches the input voltage, EAO signal is allowed to exceed the saw-tooth ramp peak in order to get a 100% duty-cycle. If voltage across BTST and PHASE pins falls below 4.3 V, a refresh cycle starts and low-side N-channel power MOSFET is turned on to recharge the BTST capacitor. It can achieve duty cycle of up to 99.5%.

9.3.6 Input Overcurrent Protection (ACOC)

The bq24735 cannot maintain the input current level if the charge current has been already reduced to zero. After the system current continues increasing to the 3.33x of input current DAC set point (with 4.2-ms blank-out time), ACFET/RBFET is latches off and an adapter removal and system shutdown is required to force ACDET < 0.6 V to reset IC. After IC reset from latch off, ACFET/RBFET can be turned on again.

The ACOG function threshold can be set to 3.33x of input DPM current or disable this function through SMBus command (ChargeOption()) bit [1]).

9.3.7 Charge Overcurrent Protection (CHGOCP)

The bq24735 has a cycle-by-cycle peak overcurrent protection. The device monitors the voltage across SRP and SRN, and prevents the current from exceeding of the threshold based on the DAC charge current set point. The high-side gate drive turns off for the rest of the cycle when the overcurrent is detected, and resumes when the next cycle starts.

The charge OCP threshold is automatically set to 6 A, 9 A, and 12 A on a 10-mΩ current-sensing resistor based on charge current register value. This prevents the threshold to be too high which is not safe or too low which can be triggered in normal operation. Proper inductance should be selected to prevent OCP triggered in normal operation due to high inductor current ripple.

9.3.8 Battery Overvoltage Protection (BATOVP)

The bq24735 will not allow the high-side and low-side MOSFET to turn on when the battery voltage at SRN exceeds 104% of the regulation voltage set-point. If BATOVP last more than 30 ms, the charger is completely disabled. This allows quick response to an overvoltage condition – such as occurs when the load is removed or the battery is disconnected. A 4-mA current sink from SRP to GND is on only during BATOVP and allows discharging the stored output inductor energy that is transferred to the output capacitors. Setting ChargeVoltage() register value to 0 V will not trigger BATOVP function.

9.3.9 Battery Shorted to Ground (BATLOWV)

The bq24735 will limit inductor current if the battery voltage on SRN falls below 2.5 V after 1-ms charge is reset. After 4-5 ms, the charge is resumed with soft start if all the enable conditions in [Enable and Disable Charging](#) are satisfied. This prevents any overshoot current in inductor which can saturate inductor and may damage the MOSFET. The charge current is limited to 0.5 A on 10-mΩ current-sensing resistor when BATLOWV condition persists and LSFET remains off. The LSFET turns on only for a refreshing pulse to charge the BTST capacitor.

9.3.10 Thermal Shutdown Protection (TSHUT)

The QFN package has low thermal impedance, which provides good thermal conduction from the silicon to the ambient, to keep junctions temperatures low. As added level of protection, the charger converter turns off for self-protection whenever the junction temperature exceeds the 155°C. The charger stays off until the junction temperature falls below 135°C. During thermal shutdown, the REGN LDO current limit is reduced to 16 mA. Once the temperature falls below 135°C, charge can be resumed with soft start.

9.3.11 Inductor Short, MOSFET Short Protection

The bq24735 has a unique short-circuit protection feature. Its cycle-by-cycle current monitoring feature is achieved through monitoring the voltage drop across $R_{DS(on)}$ of the MOSFETs after a certain amount of blanking time. In case of MOSFET short or inductor short circuit, the overcurrent condition is sensed by two comparators and two counters will be triggered. After seven times of short circuit events, the charger will be latched off and ACFET and RBFET are turned off to disconnect adapter from system. BATFET is turned on to connect battery pack to system. To reset the charger from latch-off status, the IC VCC pin must be pulled below UVLO or the ACDT pin must be pulled below 0.6 V. This can be achieved by removing the adapter and shutting down the operation system. The low-side MOSFET short circuit voltage drop threshold can be adjusted through SMBus command. ChargeOption() bit [7] = 0, 1 sets the low-side threshold to 135 mV and 230 mV, respectively. The high-side MOSFET short circuit voltage drop threshold can be adjusted through SMBus command. ChargeOption() bit [8] = 0, 1 disables the function and sets the threshold to 750 mV, respectively. During boost function, if the low-side MOSFET short-circuit protection threshold is used for cycle-by-cycle current limiting, the charger will not latch up.

Due to the certain amount of blanking time to prevent noise when MOSFET just turns on, the cycle-by-cycle charge overcurrent protection may detect high current and turn off MOSFET first before the short circuit protection circuit can detect short condition because the blanking time has not finished. In such a case, the charger may not be able to detect short circuit and counter may not be able to count to seven then latch off. Instead, the charger may continuously keep switching with very narrow duty cycle to limit the cycle-by-cycle current peak value. However, the charger should still be safe and will not cause failure because the duty cycle is limited to a very short of time and MOSFET should be still inside the safety operation area. During a soft start period, it may take a long time instead of just seven switching cycles to detect short circuit based on the same blanking time reason.

9.4 Device Functional Modes

9.4.1 Enable and Disable Charging

In Charge mode, the following conditions have to be valid to start charge:

- Charge is enabled through SMBus (ChargeOption() bit [0] = 0, default is 0, charge enabled).
- ILIM pin voltage is higher than 105 mV.
- All three regulation limit DACs have valid value programmed.
- ACOK is valid (see [Adapter Detect and ACOK Output](#) for details).
- ACFET and RBFET turns on and gate voltage is high enough (see [System Power Selection](#) for details).
- V_{SRN} does not exceed BATOVP threshold.
- IC Temperature does not exceed TSHUT threshold.
- Not in ACOC condition (see [Input Overcurrent Protection \(ACOC\)](#) for details).

One of the following conditions will stop ongoing charging:

- Charge is inhibited through SMBus (ChargeOption() bit [0] = 1).
- ILIM pin voltage lower than 75 mV.
- One of three regulation limit DACs is set to 0 or out of range.
- ACOK is pulled low (see [Adapter Detect and ACOK Output](#) for details).
- ACFET turns off.
- V_{SRN} exceeds BATOVP threshold.
- TSHUT IC temperature threshold is reached.
- ACOC is detected (see [Input Overcurrent Protection \(ACOC\)](#) for details).
- Short circuit is detected (see [Inductor Short, MOSFET Short Protection](#) for details).
- Watchdog timer expires if watchdog timer is enabled (see [Charge Time-out](#) for details).

Device Functional Modes (continued)

9.4.2 Continuous Conduction Mode (CCM)

With sufficient charge current the bq24735's inductor current never crosses zero, which is defined as continuous conduction mode. The controller starts a new cycle with ramp coming up from 200 mV. As long as EAO voltage is above the ramp voltage, the high-side MOSFET (HSFET) stays on. When the ramp voltage exceeds EAO voltage, HSFET turns off and low-side MOSFET (LSFET) turns on. At the end of the cycle, ramp gets reset and LSFET turns off, ready for the next cycle. There is always break-before-make logic during transition to prevent cross-conduction and shoot-through. During the dead time when both MOSFETs are off, the body-diode of the low-side power MOSFET conducts the inductor current.

During CCM mode, the inductor current is always flowing and creates a fixed two-pole system. Having the LSFET turnon keeps the power dissipation low, and allows safely charging at high currents.

9.4.3 Discontinuous Conduction Mode (DCM)

During the HSFET off time when LSFET is on, the inductor current decreases. If the current goes to zero, the converter enters Discontinuous Conduction Mode. Every cycle, when the voltage across SRP and SRN falls below 5 mV (0.5 A on 10 mΩ), the undercurrent protection comparator (UCP) turns off LSFET to avoid negative inductor current, which may boost the system via the body diode of HSFET.

During the DCM mode the loop response automatically changes. It changes to a single-pole system and the pole is proportional to the load current.

Both CCM and DCM are synchronous operation with LSFET turnon every clock cycle. If the average charge current goes below 125 mA on a 10-mΩ current sensing resistor, or the battery voltage falls below 2.5 V, the LSFET keeps turnoff. The battery charger operates in nonsynchronous mode and the current flows through the LSFET body diode. During nonsynchronous operation, the LSFET turns on only for a refreshing pulse to charge the BTST capacitor. If the average charge current goes above 250 mA on a 10-mΩ current-sensing resistor, the LSFET exits nonsynchronous mode and enters synchronous mode to reduce LSFET power loss.

9.5 Programming

9.5.1 SMBus Interface

The bq24735 device operates as a slave, receiving control inputs from the embedded controller host through the SMBus interface. The bq24735 uses a simplified subset of the commands documented in System Management Bus Specification V1.1, which can be downloaded from www.smbus.org. The bq24735 uses the SMBus Read-Word and Write-Word protocols (see [Figure 12](#)) to communicate with the smart battery. The bq24735 performs only as a SMBus slave device with address 0b00010010 (0x12H) and does not initiate communication on the bus. In addition, the bq24735 has two identification registers a 16-bit device ID register (0xFFH) and a 16-bit manufacturer ID register (0xFEH).

SMBus communication is enabled with the following conditions:

- V_{VCC} is above UVLO.
- V_{ACDET} is above 0.6 V.

The data (SDA) and clock (SCL) pins have Schmitt-trigger inputs that can accommodate slow edges. Choose pullup resistors (10 kΩ) for SDA and SCL to achieve rise times according to the SMBus specifications. Communication starts when the master signals a START condition, which is a high-to-low transition on SDA, while SCL is high. When the master has finished communicating, the master issues a STOP condition, which is a low-to-high transition on SDA, while SCL is high. The bus is then free for another transmission. [Figure 13](#) and [Figure 14](#) show the timing diagram for signals on the SMBus interface. The address byte, command byte, and data bytes are transmitted between the START and STOP conditions. The SDA state changes only while SCL is low, except for the START and STOP conditions. Data is transmitted in 8-bit bytes and is sampled on the rising edge of SCL. Nine clock cycles are required to transfer each byte in or out of the bq24735, because either the master or the slave acknowledges the receipt of the correct byte during the ninth clock cycle. The bq24735 supports the charger commands as described in [Table 2](#).

Programming (continued)

a) Write-Word Format

S	SLAVE ADDRESS	W	ACK	COMMAND BYTE	ACK	LOW DATA BYTE	ACK	HIGH DATA BYTE	ACK	P
	7 BITS	1b	1b	8 BITS	1b	8 BITS	1b	8 BITS	1b	
	MSB LSB	0	0	MSB LSB	0	MSB LSB	0	MSB LSB	0	

Preset to 0b0001001 ChargeCurrent() = 0x14H D7 D0 D15 D8
 ChargeVoltage() = 0x15H
 InputCurrent() = 0x3FH
 ChargeOption() = 0x12H

b) Read-Word Format

S	SLAVE ADDRESS	W	ACK	COMMAND BYTE	ACK	S	SLAVE ADDRESS	R	ACK	LOW DATA BYTE	ACK	HIGH DATA BYTE	NACK	P
	7 BITS	1b	1b	8 BITS	1b		7 BITS	1b	1b	8 BITS	1b	8 BITS	1b	
	MSB LSB	0	0	MSB LSB	0		MSB LSB	1	0	MSB LSB	0	MSB LSB	1	

Preset to 0b0001001 DeviceID() = 0xFFH Preset to D7 D0 D15 D8
 ManufactureID() = 0xFEH 0b0001001
 ChargeCurrent() = 0x14H
 ChargeVoltage() = 0x15H
 InputCurrent() = 0x3FH
 ChargeOption() = 0x12H

LEGEND:
 S = START CONDITION OR REPEATED START CONDITION P = STOP CONDITION
 ACK = ACKNOWLEDGE (LOGIC-LOW) NACK = NOT ACKNOWLEDGE (LOGIC-HIGH)
 W = WRITE BIT (LOGIC-LOW) R = READ BIT (LOGIC-HIGH)



Figure 12. SMBus Write-Word and Read-Word Protocols

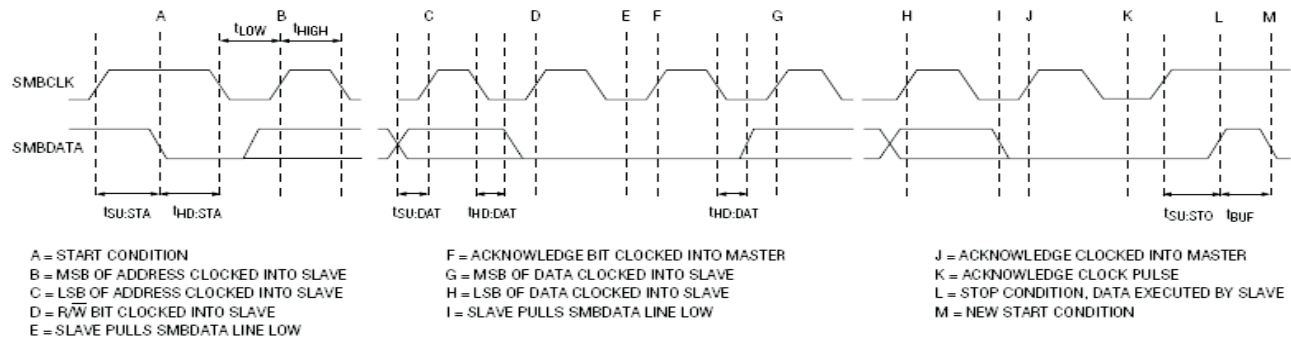

Figure 13. SMBus Write Timing

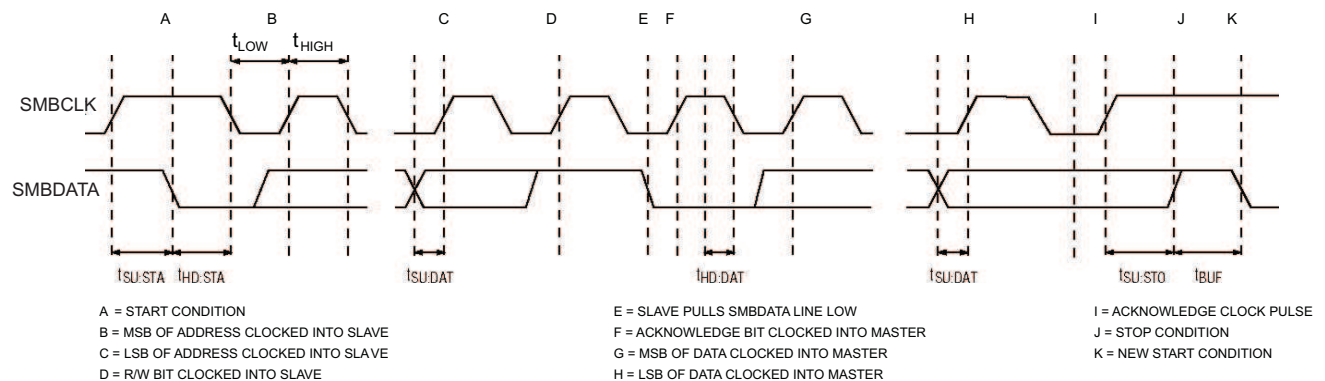

Figure 14. SMBus Read Timing

Programming (continued)

9.5.2 Battery LEARN Cycle

A battery LEARN cycle can be activated through SMBus command (ChargeOption() bit [6] = 1 enable LEARN cycle, bit [6] = 0 disable LEARN cycle). When LEARN is enabled with ACFET/RBFET connected, the system power selector logic is overdriven to switch to battery by turning off ACFET/RBFET and turning on BATFET. LEARN function allows the battery to discharge in order to calibrate the battery gas gauge over a complete discharge/charge cycle. The controller automatically exits LEARN cycle when the battery voltage is below battery depletion threshold, and the system switches back to adapter input by turning off BATFET and turning on ACFET/RBFET. After LEARN cycle, the LEARN bit is automatically reset to 0. The battery depletion threshold can be set to 59.19%, 62.65%, 66.55%, and 70.97% of voltage regulation level through SMBus command (ChargeOption() bit [12:11]).

9.5.3 Charge Time-out

The bq24735 includes a watchdog timer to terminate charging if the charger does not receive a write ChargeVoltage() or write ChargeCurrent() command within 175 s (adjustable through ChargeOption() command). If a watchdog time-out occurs all register values keep unchanged but charge is suspended. Write ChargeVoltage() or write ChargeCurrent() commands must be resent to reset watchdog timer and resume charging. The watchdog timer can be disabled, or set to 44 s, 88 s or 175 s through SMBus command (ChargeOption() bit [14:13]). After watchdog time-out write ChargeOption() bit [14:13] to disable watchdog timer also resume charging.

9.5.4 High-Accuracy Current-Sense Amplifier

As an industry standard, high-accuracy current-sense amplifier (CSA) is used to monitor the input current or the charge current, selectable through SMBUS (ChargeOption() bit [5] = 0 select the input current, bit [5] = 1 select the charge current) by host. The CSA senses voltage across the sense resistor by a factor of 20 through the IOUT pin. Once VCC is above UVLO and ACDET is above 0.6 V, CSA turns on and IOUT output becomes valid. To lower the voltage on current monitoring, a resistor divider from IOUT to GND can be used and accuracy over temperature can still be achieved.

A 100-pF capacitor connected on the output is recommended for decoupling high-frequency noise. An additional RC filter is optional, if additional filtering is desired.

NOTE

Adding filtering also increases response delay.

9.5.5 EMI Switching Frequency Adjust

The charger switching frequency can be adjusted $\pm 18\%$ to solve the EMI issue through SMBus command. ChargeOption() bit [9] = 0 disables the frequency adjust function. To enable frequency adjust function, set ChargeOption() bit [9] = 1. Set ChargeOption() bit [10] = 0 to reduce switching frequency, and set bit [10] = 1 to increase switching frequency.

If frequency is reduced for a fixed inductor, the current ripple is increased. Inductor value must be carefully selected so that it will not trigger cycle-by-cycle peak overcurrent protection, even for the worst conditions such as higher input voltage, 50% duty cycle, lower inductance, and lower switching frequency.

9.6 Register Maps

9.6.1 Battery-Charger Commands

The bq24735 supports six battery-charger commands that use either Write-Word or Read-Word protocols, as summarized in [Table 2](#). ManufacturerID() and DeviceID() can be used to identify the bq24735. The ManufacturerID() command always returns 0x0040H and the DeviceID() command always returns 0x001BH.

Table 2. Battery Charger Command Summary

REGISTER ADDRESS	REGISTER NAME	READ/WRITE	DESCRIPTION	POR STATE
0x12H	ChargeOption()	Read or Write	Charger Options Control	0xF902H
0x14H	ChargeCurrent()	Read or Write	7-Bit Charge Current Setting	0x0000H
0x15H	ChargeVoltage()	Read or Write	11-Bit Charge Voltage Setting	0x0000H
0x3FH	InputCurrent()	Read or Write	6-Bit Input Current Setting	0x1000H
0XFEH	ManufacturerID()	Read Only	Manufacturer ID	0x0040H
0xFFH	DeviceID()	Read Only	Device ID	0x001BH

9.6.2 Setting Charger Options

By writing ChargeOption() command (0x12H or 0b00010010), bq24735 allows users to change several charger options after POR (Power On Reset) as shown in [Table 3](#).

9.6.3 Charge Options Register [reset = 0x12H]

Figure 15. Charge Options Register

15	14	13	12	11	10	9	8
ACOK Deglitch Time Adjust	WATCHDOG Timer Adjust		BAT Depletion Comparator Threshold Adjust		EMI Switching Frequency Adjust	EMI Switching Frequency Enable	IFault_HI Comparator Threshold Adjust
R/W	R/W		R/W R/W		R/W	R/W	R/W
7	6	5	4	3	2	1	0
IFault_LOW Comparator Threshold Adjust	LEARN Enable	IOOUT Selection	AC Adapter Indication (Read Only)	BOOST Enable	Boost Mode Indication (Read Only)	ACOC Threshold Adjust	Charge Inhibit
R/W	R/W	R/W	R/W	R/W	R/W	R/W	R/W

LEGEND: R/W = Read/Write; R = Read only; -n = value after reset

Table 3. Charge Options Field Descriptions

Bit	Field	Type	Reset	Description
[15]	ACOK Deglitch Time Adjust		R/W	Adjust ACOK deglitch time. After POR, the first time the adapter plug in occurs, deglitch time is always 150 ms no matter if this bit is 0 or 1. This bit only sets the next ACOK deglitch time after ACFET turns off at least one time. To change this option, VCC pin voltage must be above UVLO and ACDET pin voltage must be above 0.6 V to enable IC SMBus communication. 0: ACOK rising edge deglitch time 150 ms 1: ACOK rising edge deglitch time 1.3 s <default at POR>

Table 3. Charge Options Field Descriptions (continued)

Bit	Field	Type	Reset	Description
[14:13]	WATCHDOG Timer Adjust		R/W	Set maximum delay between consecutive SMBus Write charge voltage or charge current command. The charge will be suspended if IC does not receive write charge voltage or write charge current command within the watchdog time period and watchdog timer is enabled. The charge will be resumed after receive write charge voltage or write charge current command when watchdog timer expires and charge suspends. During boost function, the timer is fixed to 175 s if it is enabled. 00: Disable Watchdog Timer 01: Enabled, 44 sec 10: Enabled, 88 sec 11: Enable Watchdog Timer (175 s) <default at POR>
[12:11]	BAT Depletion Comparator Threshold Adjust		R/W	This is used for LEARN function and boost mode function battery over discharge protection. During LEARN cycle, when the IC detects battery voltage is below depletion voltage threshold, the IC turns off BATFET and turned on ACFET to power the system from AC adapter instead of the battery. During boost mode function, when the IC detects battery voltage is below depletion voltage threshold, IC stops boost function. The rising edge hysteresis is 340 mV. Set ChargeVoltage() register value to 0 V will disable this function. 00: Falling Threshold = 59.19% of voltage regulation limit (approximately 2.486 V/cell) 01: Falling Threshold = 62.65% of voltage regulation limit (approximately 2.631 V/cell) 10: Falling Threshold = 66.55% of voltage regulation limit (approximately 2.795 V/cell) 11: Falling Threshold = 70.97% of voltage regulation limit (approximately 2.981 V/cell) < default at POR>
[10]	EMI Switching Frequency Adjust		R/W	0: Reduce PWM switching frequency by 18% <default at POR> 1: Increase PWM switching frequency by 18%
[9]	EMI Switching Frequency Enable		R/W	0: Disable adjust PWM switching frequency <default at POR> 1: Enable adjust PWM switching frequency
[8]	IFault_HI Comparator Threshold Adjust		R/W	Short circuit protection high-side MOSFET voltage drop comparator threshold. 0: function is disabled 1: 750 mV <default at POR>
[7]	IFault_LOW Comparator Threshold Adjust		R/W	Short circuit protection low-side MOSFET voltage drop comparator threshold. This is also used for cycle-by-cycle current limit protection threshold during boost function. 0: 135 mV <default at POR> 1: 230 mV
[6]	LEARN Enable		R/W	Set this bit 1 start battery learn cycle. IC turns off ACFET and turns on BATFET to discharge battery capacity. When battery voltage reaches threshold defined in bit [12;11], the BATFET is turned off and ACFET is turned on to finish battery learn cycle. After finished learn cycle, this bit is automatically reset to 0. Set this bit 0 will stop battery learn cycle. IC turns off BATFET and turns on ACFET. 0: Disable LEARN Cycle <default at POR> 1: Enable LEARN Cycle
[5]	IOU Selection		R/W	0: IOU is the 20x adapter current amplifier output <default at POR> 1: IOU is the 20x charge current amplifier output
[4]	AC Adapter Indication (Read Only)		R/W	0: AC adapter is not present (ACDET < 2.4 V) <default at POR> 1: AC adapter is present (ACDET > 2.4 V)
[3]	BOOST Enable		R/W	0: Disable Turbo Boost function <default at POR> 1: Enable Turbo Boost function
[2]	Boost Mode Indication (Read Only)		R/W	0: Charger is not in boost mode <default at POR> 1: Charger is in boost mode
[1]	ACOC Threshold Adjust		R/W	0: function is disabled 1: 3.33x of input current regulation limit <default at POR>

Table 3. Charge Options Field Descriptions (continued)

Bit	Field	Type	Reset	Description
[0]	Charge Inhibit		R/W	0: Enable Charge <default at POR> 1: Inhibit Charge

9.6.4 Setting the Charge Current

To set the charge current, write a 16-bit ChargeCurrent() command (0x14H or 0b00010100) using the data format listed in Table 4. With 10-mΩ sense resistor, the bq24735 provides a charge current range of 128 mA to 8.128 A, with 64-mA step resolution. Sending ChargeCurrent() below 128 mA or above 8.128 A clears the register and terminates charging. Upon POR, charge current is 0 A. TI recommends a 0.1-μF capacitor between SRP and SRN for differential mode filtering, a 0.1-μF capacitor between SRN and ground for common mode filtering, and an optional 0.1-μF capacitor between SRP and ground for common mode filtering. Meanwhile, the capacitance on SRP should not be higher than 0.1 μF to properly sense the voltage across SRP and SRN for cycle-by-cycle undercurrent and overcurrent detection.

The SRP and SRN pins are used to sense R_{SR} with default value of 10 mΩ. However, resistors of other values can also be used. For a larger sense resistor, a larger sense voltage is given, and a higher regulation accuracy; but, at the expense of higher conduction loss. If the current-sensing resistor value is too high, it may trigger an overcurrent protection threshold because the current ripple voltage is too high. In such a case, either a higher inductance value or a lower current-sensing resistor value should be used to limit the current ripple voltage level. A current-sensing resistor value no more than 20 mΩ is suggested.

To provide secondary protection, the bq24735 has an ILIM pin with which the user can program the maximum allowed charge current. Internal charge current limit is the lower one between the voltage set by ChargeCurrent(), and voltage on ILIM pin. To disable this function, the user can pull ILIM above 1.6 V, which is the maximum charge current regulation limit. Equation 2 shows the voltage set on the ILIM pin with respect to the preferred charge current limit:

$$V_{ILIM} = 20 \times (V_{SRP} - V_{SRN}) = 20 \times I_{CHG} \times R_{SR} \quad (2)$$

Table 4. Charge Current Register (0x14H), Using a 10-mΩ Sense Resistor

BIT	BIT NAME	DESCRIPTION
0	–	Not used.
1	–	Not used.
2	–	Not used.
3	–	Not used.
4	–	Not used.
5	–	Not used.
6	Charge Current, DACICHG 0	0 = Adds 0 mA of charger current. 1 = Adds 64 mA of charger current.
7	Charge Current, DACICHG 1	0 = Adds 0 mA of charger current. 1 = Adds 128 mA of charger current.
8	Charge Current, DACICHG 2	0 = Adds 0 mA of charger current. 1 = Adds 256 mA of charger current.
9	Charge Current, DACICHG 3	0 = Adds 0 mA of charger current. 1 = Adds 512 mA of charger current.
10	Charge Current, DACICHG 4	0 = Adds 0 mA of charger current. 1 = Adds 1024 mA of charger current.
11	Charge Current, DACICHG 5	0 = Adds 0 mA of charger current. 1 = Adds 2048 mA of charger current.
12	Charge Current, DACICHG 6	0 = Adds 0 mA of charger current. 1 = Adds 4096 mA of charger current.
13	–	Not used.
14	–	Not used.
15	–	Not used.

9.6.5 Setting the Charge Voltage

To set the output charge regulation voltage, write a 16-bit ChargeVoltage() command (0x15H or 0b0001#0101) using the data format listed in Table 5. The bq24735 provides charge voltage range from 1.024 V to 19.200 V, with a 16-mV step resolution. Sending ChargeVoltage() below 1.024 V or above 19.2 V clears the register and terminates charging. Upon POR, charge voltage limit is 0 V.

The SRN pin is used to sense the battery voltage for voltage regulation and should be connected as close to the battery as possible. Place a decoupling capacitor (0.1 μF recommended) as close to the IC as possible to decouple high-frequency noise.

Table 5. Charge Voltage Register (0x15H)

BIT	BIT NAME	DESCRIPTION
0	-	Not used.
1	-	Not used.
2	-	Not used.
3	-	Not used.
4	Charge Voltage, DACV 0	0 = Adds 0 mV of charger voltage. 1 = Adds 16 mV of charger voltage.
5	Charge Voltage, DACV 1	0 = Adds 0 mV of charger voltage. 1 = Adds 32 mV of charger voltage.
6	Charge Voltage, DACV 2	0 = Adds 0 mV of charger voltage. 1 = Adds 64 mV of charger voltage.
7	Charge Voltage, DACV 3	0 = Adds 0 mV of charger voltage. 1 = Adds 128 mV of charger voltage.
8	Charge Voltage, DACV 4	0 = Adds 0 mV of charger voltage. 1 = Adds 256 mV of charger voltage.
9	Charge Voltage, DACV 5	0 = Adds 0 mV of charger voltage. 1 = Adds 512 mV of charger voltage.
10	Charge Voltage, DACV 6	0 = Adds 0 mV of charger voltage. 1 = Adds 1024 mV of charger voltage.
11	Charge Voltage, DACV 7	0 = Adds 0 mV of charger voltage. 1 = Adds 2048 mV of charger voltage.
12	Charge Voltage, DACV 8	0 = Adds 0 mV of charger voltage. 1 = Adds 4096 mV of charger voltage.
13	Charge Voltage, DACV 9	0 = Adds 0 mV of charger voltage. 1 = Adds 8192 mV of charger voltage.
14	Charge Voltage, DACV 10	0 = Adds 0 mV of charger voltage. 1 = Adds 16384 mV of charger voltage.
15	-	Not used.

9.6.6 Setting Input Current

System current normally fluctuates as portions of the system are powered up or put to sleep. With the input current limit, the output current requirement of the AC wall adapter can be lowered, reducing system cost.

The total input current, from a wall cube or other DC source, is the sum of the system supply current and the current required by the charger. When the input current exceeds the set input current limit, the bq24735 decreases the charge current to provide priority to system load current. As the system current rises, the available charge current drops linearly to zero. Thereafter, all input current goes to system load and input current increases.

During DPM regulation, the total input current is the sum of the device supply current I_{BIAS} , the charger input current, and the system load current I_{LOAD} , and can be estimated as follows:

$$I_{INPUT} = I_{LOAD} + \left[\frac{I_{BATTERY} \times V_{BATTERY}}{V_{IN} \times \eta} \right] + I_{BIAS}$$

where

- η is the efficiency of the charger buck converter (typically 85% to 95%). (3)

To set the input current limit, write a 16-bit InputCurrent() command (0x3FH or 0b0011#1111) using the data format listed in Table 6. When using a 10-mΩ sense resistor, the bq24735 provides an input current-limit range of 128 mA to 8.064 A, with 128-mA resolution. The suggested input current limit is set to no less than 512 mA. Sending InputCurrent() below 128 mA or above 8.064 A clears the register and terminates charging. Upon POR, the default input current limit is 4096 mA.

The ACP and ACN pins are used to sense R_{AC} with default value of 10 mΩ. However, resistors of other values can also be used. For a larger sense resistor, larger sense voltage is given, and a higher regulation accuracy; but, at the expense of higher conduction loss.

If input current rises above FAST_DPM threshold, the charger will reduce charging current to allow the input current drop. After a typical 260-μs delay time, if input current is still above FAST_DPM threshold, the charger will shut down. When the system load current becomes smaller, the charger will soft restart to charge the battery if the adapter still has power to charge the battery. This prevents a crash if the adapter is overloaded when the system has a high and fast loading transient. The waiting time between shut down and restart charging is a natural response time of the input current limit loop.

Table 6. Input Current Register (0x3FH), Using a 10-mΩ Sense Resistor

BIT	BIT NAME	DESCRIPTION
0	–	Not used.
1	–	Not used.
2	–	Not used.
3	–	Not used.
4	–	Not used.
5	–	Not used.
6	–	Not used.
7	Input Current, DACIIN 0	0 = Adds 0 mA of input current. 1 = Adds 128 mA of input current.
8	Input Current, DACIIN 1	0 = Adds 0 mA of input current. 1 = Adds 256 mA of input current.
9	Input Current, DACIIN 2	0 = Adds 0 mA of input current. 1 = Adds 512 mA of input current.
10	Input Current, DACIIN 3	0 = Adds 0 mA of input current. 1 = Adds 1024 mA of input current.
11	Input Current, DACIIN 4	0 = Adds 0 mA of input current. 1 = Adds 2048 mA of input current.
12	Input Current, DACIIN 5	0 = Adds 0 mA of input current. 1 = Adds 4096 mA of input current.
13	–	Not used.
14	–	Not used.
15	–	Not used.

9.6.7 Support Turbo Boost Function

The bq24735 supports Turbo Boost function when the adapter is above 16 V. During Turbo Boost mode, battery discharge energy is delivered to system when system power demand is temporarily higher than adapter maximum power level so that adapter will not crash. After POR, the ChargeOption() bit [3] is 0 which disable Turbo Boost function. To enable it, the ChargeOption() bit [3] must be written to 1 by the host.

When input current is higher than the FAST_DPM comparator threshold, if Turbo Boost function is enabled, charger IC will allow battery discharge and charger converter will change from buck converter to boost converter. During Turbo Boost mode the adapter current is regulated at input current limit level so that adapter will not crash. The battery discharge current depends on system current requirement and adapter current limit. The SMBus timer can be enabled to prevent converter running at Turbo Boost mode for too long.

10 Application and Implementation

NOTE

Information in the following applications sections is not part of the TI component specification, and TI does not warrant its accuracy or completeness. TI's customers are responsible for determining suitability of components for their purposes. Customers should validate and test their design implementation to confirm system functionality.

10.1 Application Information

The bq24725A/735EVM-710 evaluation module (EVM) is a complete charger module for evaluating the bq24735. The application curves were taken using the bq24725A/735EVM-710. Refer to the EVM user's guide (SLUU507) for EVM information.

10.2 Typical Application

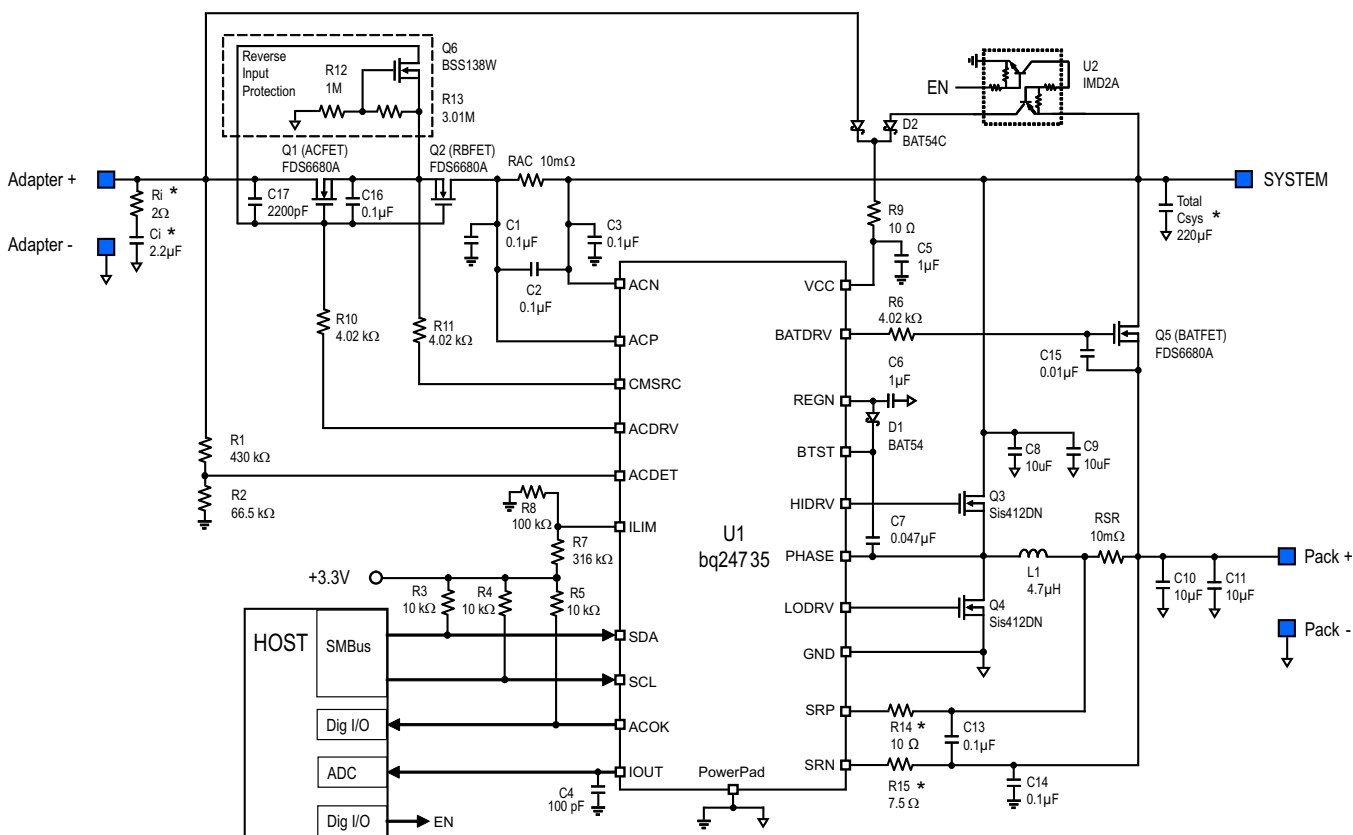

$F_s = 750 \text{ kHz}$, $I_{ADPT} = 4.096 \text{ A}$, $I_{CHRG} = 2.944 \text{ A}$, $I_{LIM} = 4 \text{ A}$, $V_{CHRG} = 12.592 \text{ V}$, 90-W adapter and 3S2P battery pack
 Use 0 Ω for better current-sensing accuracy, use 10- Ω or 7.5- Ω resistor for reversed battery connection protection.
 See [Negative Output Voltage Protection](#).

The total C_{sys} is the lump sum of system capacitance. It is not required by charger IC. Use Ri and Ci for adapter hot plug-in voltage spike damping. See [Input Filter Design](#).

Figure 16. Typical System Schematic With Two NMOS Selectors

Typical Application (continued)

10.2.1 Design Requirements

For this design example, use the parameters listed in [Table 7](#) as the input parameters.

Table 7. Design Parameters

DESIGN PARAMETER	EXAMPLE VALUE
Input Voltage ⁽¹⁾	17.7 V < Adapter Voltage < 24 V
Input Current Limit ⁽¹⁾	3.2 A for 65-W adapter
Battery Charge Voltage ⁽²⁾	12592 mV for 3-s battery
Battery Charge Current ⁽²⁾	4096 mA for 3-s battery
Battery Discharge Current ⁽²⁾	6144 mA for 3-s battery

(1) Refer to adapter specification for settings for input voltage and input current limit.

(2) Refer to battery specification for settings.

10.2.2 Detailed Design Procedure

10.2.2.1 Negative Output Voltage Protection

If the battery pack is inserted in reverse order into the charger, output during production or hard shorts on battery-to-ground generates negative output voltage on the SRP and SRN pins. IC internal electrostatic-discharge (ESD) diodes from the GND pin to the SRP or SRN pins and two anti-parallel (AP) diodes between the SRP and SRN pins can be forward-biased and negative current can pass through the ESD diodes and AP diodes when output has negative voltage. Insert two small resistors for SRP and SRN pins to limit the negative current level when output has negative voltage. Suggested resistor value is 10 Ω for the SRP pin and 7 to 8 Ω for the SRN pin. After adding small resistors, the suggested precharge current is at least 192 mA for a 10-m Ω current-sensing resistor. Another method is using a small diode parallel with output capacitor; when battery connection is reversed, the diode turns on and limits the negative voltage level. Using diode protection method without insertion of small resistors into the SRP and SRN pins can get the best charging current accuracy.

10.2.2.2 Reverse Input Voltage Protection

Q6, R12 and R13 in [Figure 16](#) gives system and IC protection from reversed adapter voltage. In normal operation, Q6 is turned off by negative Vgs. When adapter voltage is reversed, Q6 Vgs is positive. As a result, Q6 turns on to short gate and source of Q2 so that Q2 is off. Q2 body diode blocks negative voltage to system. However, CMSRC and ACDRV pins need R10 and R11 to limit the current due to the ESD diode of these pins when turned on. Q6 must have low Vgs threshold voltage and low Qgs gate charge, so it turns on before Q2 turns on. R10 and R11 must have enough power rating for the power dissipation when the ESD diode is on. In [Figure 21](#), the Schottky diode D3 gives the reverse adapter voltage protection, no extra small MOSFET and resistors are needed.

In [Figure 22](#), the Schottky diode Din is used for the reverse adapter voltage protection.

10.2.2.3 Reduce Battery Quiescent Current

When the adapter is not present, if VCC is powered with voltage higher than UVLO directly or indirectly (such as through a LDO or switching converter) from battery, the internal BATFET charge pump gives the BATFET pin 6 V higher voltage than the SRN pin to drive the N-channel BATFET. As a result, the battery has higher quiescent current. This is only necessary when the battery powers the system due to a high system current that goes through the MOSFET channel instead of the body diode to reduce conduction loss and extend the battery working life. When the system is totally shut down, it is not necessary to let the internal BATFET charge pump work. The host controller can use a digital signal EN to disconnect the battery power path to the VCC pin by U2 in [Figure 16](#). As a result, battery quiescent current can be minimized. The host controller still can get power from BATFET body diode because the total system current is the lowest when the system is shut down, so there is no high conduction loss of the body diode.

10.2.2.4 Inductor Selection

The bq24735 has three selectable fixed switching frequencies. Higher switching frequency allows the use of smaller inductor and capacitor values. Inductor saturation current should be higher than the charging current (I_{CHG}) plus half the ripple current (I_{RIPPLE}):

$$I_{SAT} \geq I_{CHG} + (1/2) I_{RIPPLE} \quad (4)$$

The inductor ripple current depends on input voltage (V_{IN}), duty cycle ($D = V_{OUT}/V_{IN}$), switching frequency (f_S) and inductance (L):

$$I_{RIPPLE} = \frac{V_{IN} \times D \times (1 - D)}{f_S \times L} \quad (5)$$

The maximum inductor ripple current happens with $D = 0.5$ or close to 0.5. For example, the battery charging voltage range is from 9 V to 12.6 V for a 3-cell battery pack. For 20-V adapter voltage, a 10-V battery voltage gives the maximum inductor ripple current. Another example is a 4-cell battery. The battery voltage range is from 12 V to 16.8 V, and 12-V battery voltage gives the maximum inductor ripple current.

Usually, inductor ripple is designed in the range of (20% to 40%) maximum charging current as a trade-off between inductor size and efficiency for a practical design.

The bq24735 has charge undercurrent protection (UCP) by monitoring charging current-sensing resistor cycle-by-cycle. The typical cycle-by-cycle UCP threshold is 5-mV falling edge corresponding to 0.5-A falling edge for a 10-m Ω charging current sensing resistor. When the average charging current is less than 125 mA for a 10-m Ω charging current-sensing resistor, the low-side MOSFET is off until BTST capacitor voltage must refresh the charge. As a result, the converter relies on low-side MOSFET body diode for the inductor freewheeling current.

10.2.2.5 Input Capacitor

Input capacitor should have enough ripple current rating to absorb input switching ripple current. The worst-case RMS ripple current is half of the charging current when duty cycle is 0.5. If the converter does not operate at 50% duty cycle, then the worst-case capacitor RMS current occurs where the duty cycle is closest to 50% and can be estimated by [Equation 6](#):

$$I_{CIN} = I_{CHG} \times \sqrt{D \times (1 - D)} \quad (6)$$

Low ESR ceramic capacitor such as X7R or X5R is preferred for input decoupling capacitor and should be placed to the drain of the high-side MOSFET and source of the low-side MOSFET as close as possible. Voltage rating of the capacitor must be higher than normal input voltage level. 25-V rating or higher capacitor is preferred for 19- to 20-V input voltage. 10- to 20- μ F capacitance is suggested for typical of 3- to 4-A charging current.

Ceramic capacitors show a DC-bias effect. This effect reduces the effective capacitance when a DC-bias voltage is applied across a ceramic capacitor, as on the input capacitor of a charger. The effect may lead to a significant capacitance drop, especially for high input voltages and small capacitor packages. See the manufacturer's data sheet about the performance with a DC-bias voltage applied. It may be necessary to choose a higher voltage rating or nominal capacitance value in order to get the required value at the operating point.

10.2.2.6 Output Capacitor

Output capacitor also should have enough ripple current rating to absorb output switching ripple current. The output capacitor RMS current is given:

$$I_{COUT} = \frac{I_{RIPPLE}}{2 \times \sqrt{3}} \approx 0.29 \times I_{RIPPLE} \quad (7)$$

The bq24735 has internal loop compensator. To get good loop stability, the resonant frequency of the output inductor and output capacitor should be designed between 10 kHz and 20 kHz. The preferred ceramic capacitor is a 25-V X7R or X5R for output capacitor. A capacitance of 10 to 20 μ F is suggested for a typical of 3- to 4-A charging current. Place the capacitors after charging current-sensing resistor to get the best charge current regulation accuracy.

Ceramic capacitors show a DC-bias effect. This effect reduces the effective capacitance when a DC-bias voltage is applied across a ceramic capacitor, as on the output capacitor of a charger. The effect may lead to a significant capacitance drop, especially for high output voltages and small capacitor packages. See the manufacturer's data sheet about the performance with a DC-bias voltage applied. It may be necessary to choose a higher voltage rating or nominal capacitance value in order to get the required value at the operating point.

10.2.2.7 Power MOSFETs Selection

Two external N-channel MOSFETs are used for a synchronous switching battery charger. The gate drivers are internally integrated into the IC with 6 V of gate drive voltage. A 30-V or higher voltage rating MOSFETs are preferred for 19- to 20-V input voltage.

Figure-of-merit (FOM) is usually used for selecting proper MOSFET based on a tradeoff between the conduction loss and switching loss. For the top-side MOSFET, FOM is defined as the product of a MOSFET ON-resistance, $R_{DS(ON)}$, and the gate-to-drain charge, Q_{GD} . For the bottom-side MOSFET, FOM is defined as the product of the MOSFET ON-resistance, $R_{DS(ON)}$, and the total gate charge, Q_G .

$$FOM_{top} = R_{DS(on)} \times Q_{GD}; FOM_{bottom} = R_{DS(on)} \times Q_G \quad (8)$$

The lower the FOM value, the lower the total power loss. Usually lower $R_{DS(ON)}$ has higher cost with the same package size.

The top-side MOSFET loss includes conduction loss and switching loss. It is a function of duty cycle ($D=V_{OUT}/V_{IN}$), charging current (I_{CHG}), MOSFET ON-resistance ($R_{DS(ON)}$), input voltage (V_{IN}), switching frequency (f_s), turnon time (t_{on}) and turnoff time (t_{off}):

$$P_{top} = D \times I_{CHG}^2 \times R_{DS(on)} + \frac{1}{2} \times V_{IN} \times I_{CHG} \times (t_{on} + t_{off}) \times f_s \quad (9)$$

The first item represents the conduction loss. Usually MOSFET $R_{DS(ON)}$ increases by 50% with 100°C junction temperature rise. The second term represents the switching loss. The MOSFET turnon and turnoff times are given by:

$$t_{on} = \frac{Q_{SW}}{I_{on}}, t_{off} = \frac{Q_{SW}}{I_{off}} \quad (10)$$

where Q_{SW} is the switching charge, I_{on} is the turnon gate driving current and I_{off} is the turnoff gate driving current. If the switching charge is not given in MOSFET data sheet, it can be estimated by gate-to-drain charge (Q_{GD}) and gate-to-source charge (Q_{GS}):

$$Q_{SW} = Q_{GD} + \frac{1}{2} \times Q_{GS} \quad (11)$$

Gate driving current can be estimated by REGN voltage (V_{REGN}), MOSFET plateau voltage (V_{plt}), total turnon gate resistance (R_{on}) and turnoff gate resistance (R_{off}) of the gate driver:

$$I_{on} = \frac{V_{REGN} - V_{plt}}{R_{on}}, I_{off} = \frac{V_{plt}}{R_{off}} \quad (12)$$

The conduction loss of the bottom-side MOSFET is calculated with the following equation when it operates in synchronous continuous conduction mode:

$$P_{bottom} = (1 - D) \times I_{CHG}^2 \times R_{DS(on)} \quad (13)$$

When charger operates in nonsynchronous mode, the bottom-side MOSFET is off. As a result all the freewheeling current goes through the body-diode of the bottom-side MOSFET. The body diode power loss depends on its forward voltage drop (V_F), nonsynchronous mode charging current (I_{NONSYN}), and duty cycle (D).

$$P_D = V_F \times I_{NONSYN} \times (1 - D) \quad (14)$$

The maximum charging current in nonsynchronous mode can be up to 0.25 A for a 10-mΩ charging current sensing resistor, or 0.5 A if battery voltage is below 2.5 V. The minimum duty cycle happens at lowest battery voltage. Choose the bottom-side MOSFET with either an internal Schottky or body diode capable of carrying the maximum nonsynchronous mode charging current.

10.2.2.8 Input Filter Design

During adapter hot plug-in, the parasitic inductance and input capacitor from the adapter cable form a second order system. The voltage spike at VCC pin maybe beyond IC maximum voltage rating and damage IC. The input filter must be carefully designed and tested to prevent overvoltage event on VCC pin.

There are several methods of damping or limiting the overvoltage spike during adapter hot plug-in. An electrolytic capacitor with high ESR as an input capacitor can damp the overvoltage spike well below the IC maximum pin voltage rating. A high current capability TVS Zener diode can also limit the overvoltage level to an IC safe level. However, these two solutions may not have low cost or small size.

A cost-effective and small-size solution is shown in Figure 17. R1 and C1 are composed of a damping RC network to damp the hot plug-in oscillation. As a result the overvoltage spike is limited to a safe level. D1 is used for reverse voltage protection for VCC pin. C2 is VCC pin decoupling capacitor and it should be place to VCC pin as close as possible. C2 value should be less than C1 value so R1 can dominant the equivalent ESR value to get enough damping effect. R2 is used to limit inrush current of D1 to prevent D1 getting damage when adapter hot plug-in. R2 and C2 should have 10-us time constant to limit the DV/DT on VCC pin to reduce inrush current when adapter hot plug in. R1 has high inrush current. R1 package must be sized enough to handle inrush current power loss according to resistor manufacturer's data sheet. The filter components value always must be verified with real application and minor adjustments may need to fit in the real application circuit.

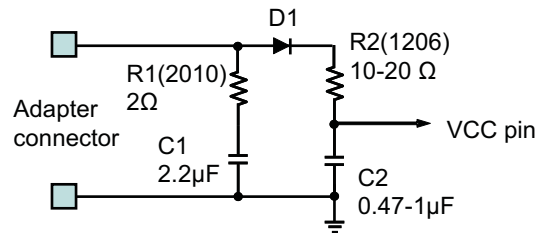

Figure 17. Input Filter

10.2.2.9 bq24735 Design Guideline

The bq24735 has a unique short-circuit protection feature. Its cycle-by-cycle current monitoring feature is achieved through monitoring the voltage drop across $R_{DS(on)}$ of the MOSFETs after a certain amount of blanking time. For a MOSFET short or inductor short circuit, the overcurrent condition is sensed by two comparators, and two counters are triggered. After seven occurrences of a short-circuit event, the charger will be latched off. To reset the charger from latch-off status, reconnect the adapter. Figure 18 shows the bq24735 short-circuit protection block diagram.

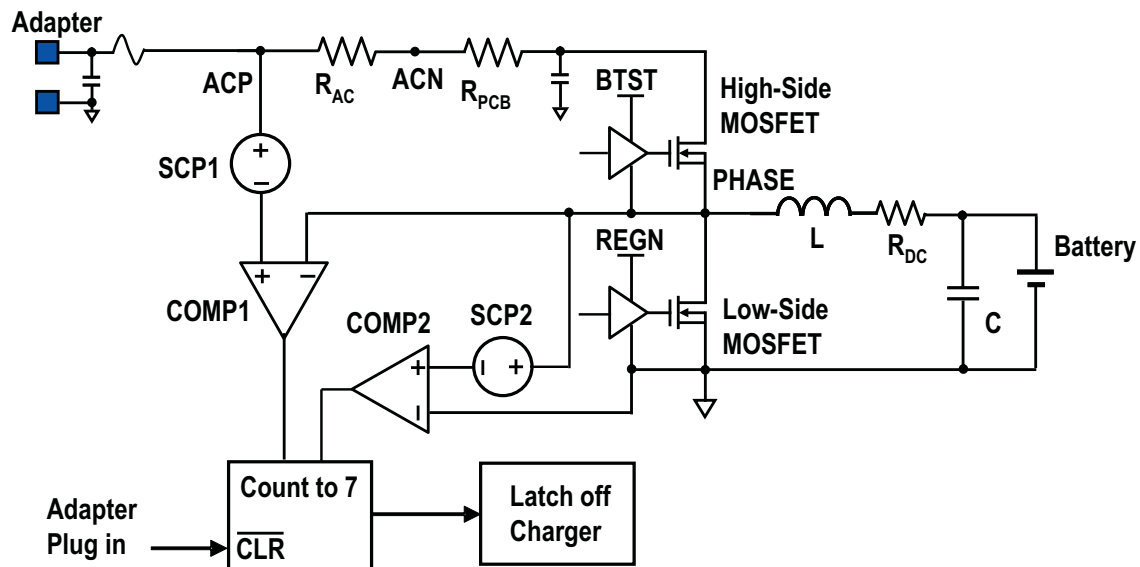

Figure 18. Block Diagram of bq24735 Short-Circuit Protection

In normal operation, the low-side MOSFET current is from source to drain which generates a negative voltage drop when it turns on. As a result, the overcurrent comparator cannot be triggered. When the high-side switch short circuit or inductor short circuit occurs, the large current of the low-side MOSFET is from drain to source and can trigger the low-side switch overcurrent comparator. bq24735 senses the low-side switch voltage drop through the PHASE pin and the GND pin.

The high-side FET short is detected by monitoring the voltage drop between ACP and PHASE. As a result, it not only monitors the high-side switch voltage drop, but also the adapter-sensing resistor voltage drop and PCB trace voltage drop from the ACN terminal of R_{AC} to the charger high-side switch drain. Usually, there is a long trace between input-sensing resistor and charger-converting input, a careful layout will minimize the trace effect.

Table 8. Component List for Typical System Circuit of Figure 16

PART DESIGNATOR	QTY	DESCRIPTION
C1, C2, C3, C13, C14, C16	6	Capacitor, Ceramic, 0.1 μ F, 25 V, 10%, X7R, 0603
C4	1	Capacitor, Ceramic, 100 pF, 25 V, 10%, X7R, 0603
C5, C6	2	Capacitor, Ceramic, 1 μ F, 25 V, 10%, X7R, 0603
C7	1	Capacitor, Ceramic, 0.047 μ F, 25 V, 10%, X7R, 0603
C8, C9, C10, C11	4	Capacitor, Ceramic, 10 μ F, 25 V, 10%, X7R, 1206
C15	1	Capacitor, Ceramic, 0.01 μ F, 25 V, 10%, X7R, 0603
C17	1	Capacitor, Ceramic, 2200 pF, 25 V, 10%, X7R, 0603
Ci	1	Capacitor, Ceramic, 2.2 μ F, 25 V, 10%, X7R, 1210
Csys	1	Capacitor, Electrolytic, 220 μ F, 25 V
D1	1	Diode, Schottky, 30 V, 200 mA, SOT-23, Fairchild, BAT54
D2	1	Diode, Dual Schottky, 30 V, 200 mA, SOT-23, Fairchild, BAT54C
Q1, Q2, Q5	3	N-channel MOSFET, 30 V, 12.5 A, SO-8, Fairchild, FDS6680A
Q3, Q4	2	N-channel MOSFET, 30 V, 12 A, PowerPAK 1212-8, Vishay Siliconix, SiS412DN
Q6	1	N-channel MOSFET, 50 V, 0.2 A, SOT-323, Diodes, BSS138W
L1	1	Inductor, SMT, 4.7 μ H, 5.5 A, Vishay Dale, IHLP2525CZER4R7M01
R1	1	Resistor, Chip, 430 k Ω , 1/10 W, 1%, 0603
R2	1	Resistor, Chip, 66.5 k Ω , 1/10 W, 1%, 0603
R3, R4, R5	3	Resistor, Chip, 10 k Ω , 1/10 W, 1%, 0603
R6, R10, R11	3	Resistor, Chip, 4.02 k Ω , 1/10 W, 1%, 0603
R7	1	Resistor, Chip, 316 k Ω , 1/10 W, 1%, 0603
R8	1	Resistor, Chip, 100 k Ω , 1/10 W, 1%, 0603
R9	1	Resistor, Chip, 10 Ω , 1/4 W, 1%, 1206
R12	1	Resistor, Chip, 1.00 M Ω , 1/10 W, 1%, 0603
R13	1	Resistor, Chip, 3.01 M Ω , 1/10 W, 1%, 0603
R14	1	Resistor, Chip, 10 Ω , 1/10 W, 5%, 0603
R15	1	Resistor, Chip, 7.5 Ω , 1/10 W, 5%, 0603
RAC, RSR	2	Resistor, Chip, 0.01 Ω , 1/2 W, 1%, 1206
Ri	1	Resistor, Chip, 2 Ω , 1/2 W, 1%, 1210
U1	1	Charger controller, 20-pin VQFN, TI, bq24735RGR
U2	1	Dual digital transistor, 40 V, 30 mA, SC-74, Rohm, IMD2A

10.2.3 Application Curves

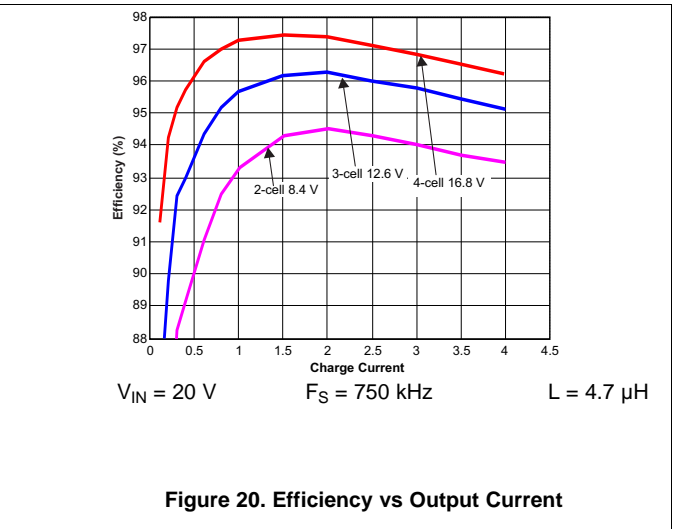
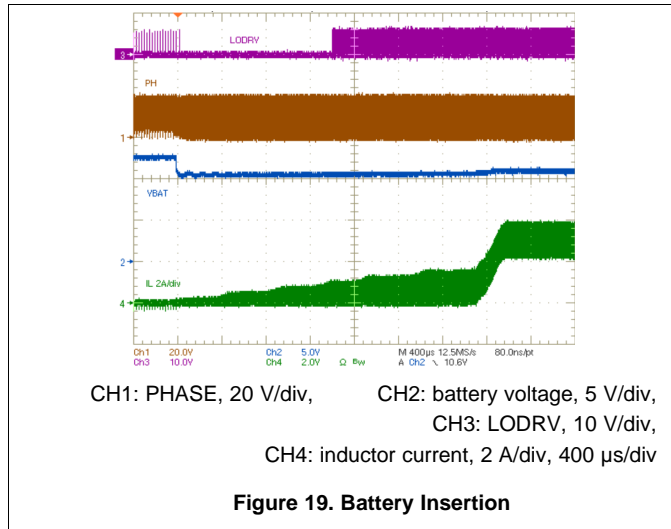

10.3 System Examples

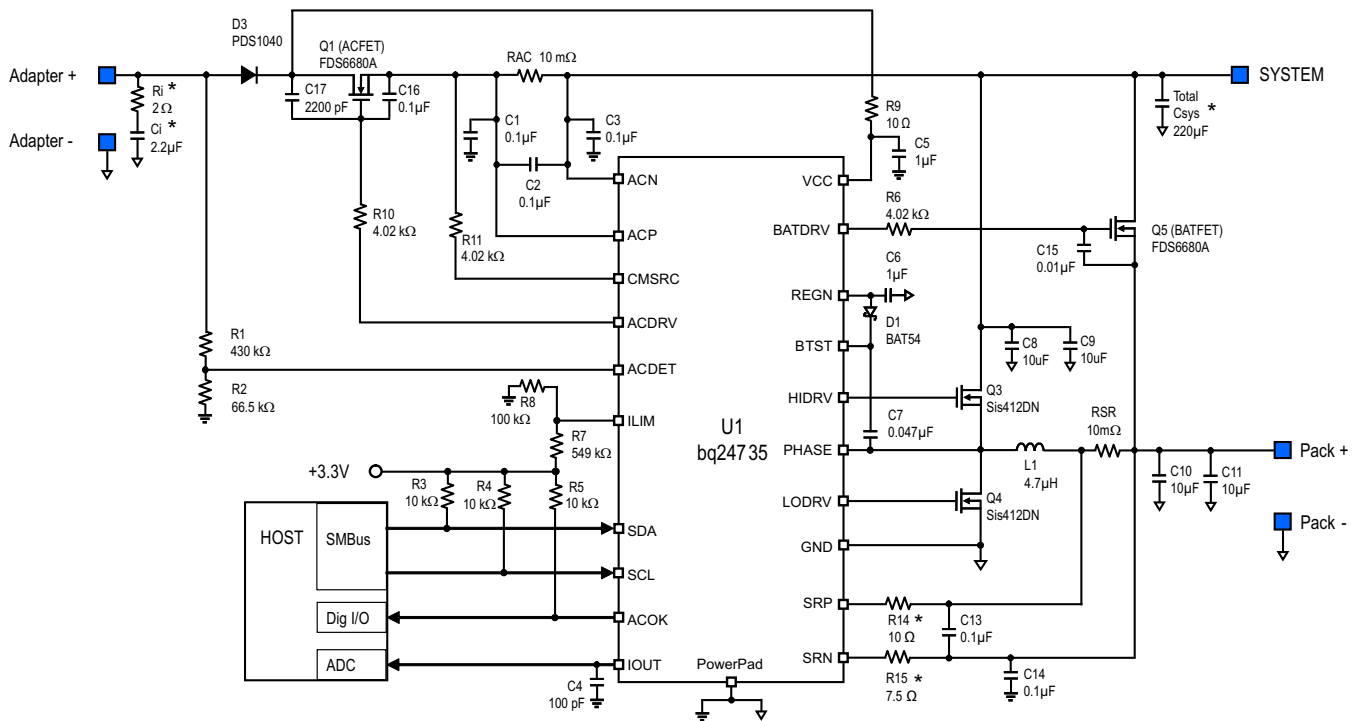

$F_S = 750\text{ kHz}$, $I_{ADPT} = 2.816\text{ A}$, $I_{CHRG} = 1.984\text{ A}$, $I_{LIM} = 2.54\text{ A}$, $V_{CHRG} = 12.592\text{ V}$, 65-W adapter and 3S2P battery pack

Use 0 Ω for better current-sensing accuracy, use 10- Ω or 7.5- Ω resistor for reversed battery connection protection. See [Negative Output Voltage Protection](#).

The total C_{sys} is the lump sum of system capacitance. It is not required by charger IC. Use R_i and C_i for adapter hot plug-in voltage spike damping. See [Input Filter Design](#).

Figure 21. Typical System Schematic With One NMOS Selector and Schottky Diode

System Examples (continued)

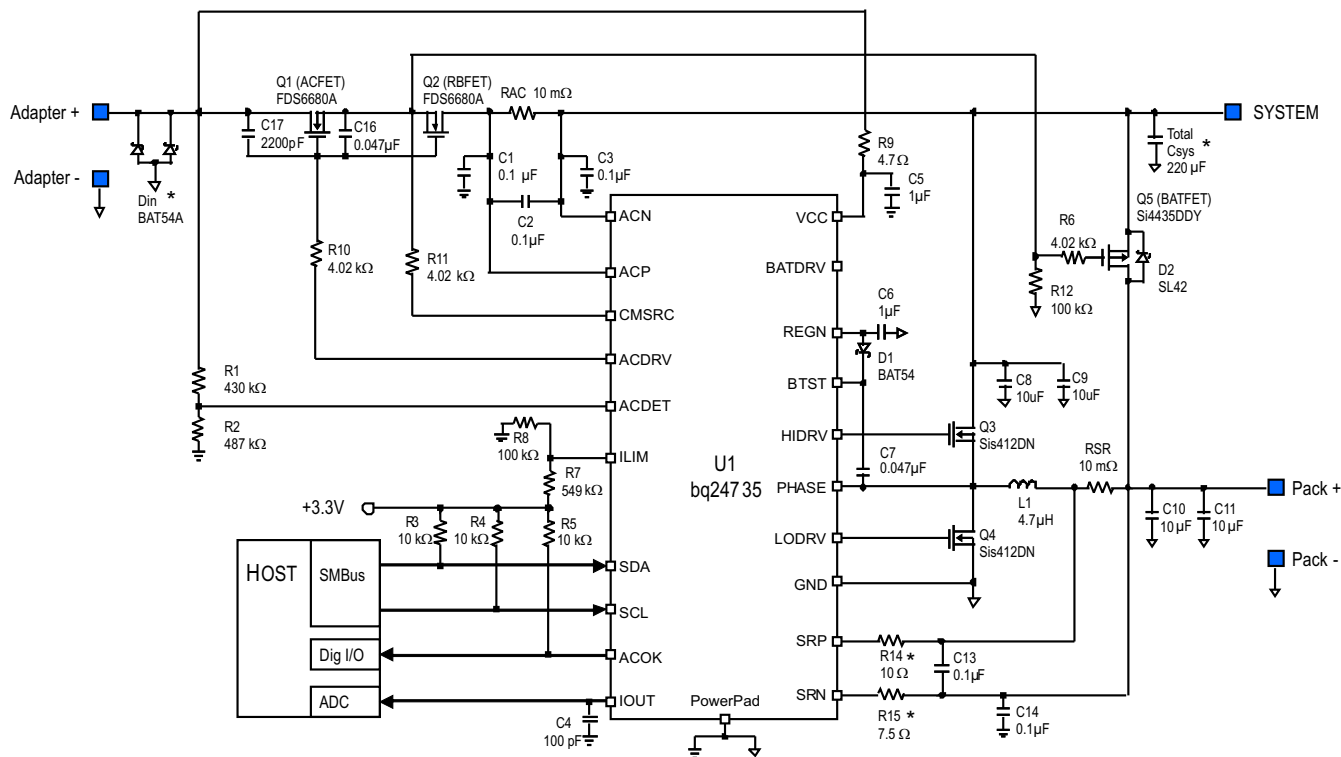

$F_s = 750 \text{ kHz}$, $I_{ADPT} = 2.048 \text{ A}$, $I_{CHRG} = 1.984 \text{ A}$, $I_{LIM} = 2.54 \text{ A}$, $V_{CHRG} = 4.200 \text{ V}$, 12-W adapter and 1S2P battery pack

Use 0 Ω for better current-sensing accuracy, use 10- Ω or 7.5- Ω resistor for reversed battery connection protection. See [Negative Output Voltage Protection](#).

The total C_{sys} is the total lump sum of system capacitance. It is not required by charger IC. Use Din for reverse input voltage protection. See [Input Filter Design](#).

Figure 22. Typical System Schematic for 5-V Input 1-S Battery

11 Power Supply Recommendations

When adapter is attached, and ACOK goes HIGH, the system is connected to adapter through ACFET/RBFET. An external resistor voltage divider attenuates the adapter voltage before it goes to ACDET. The adapter detect threshold should typically be programmed to a value greater than the maximum battery voltage, but lower than the IC maximum allowed input voltage and system maximum allowed voltage.

When adapter is removed, the system is connected to battery through BATFET. Typically the battery depletion threshold should be greater than the minimum system voltage so that the battery capacity can be fully used for maximum battery life.

12 Layout

12.1 Layout Guidelines

The switching node rise and fall times should be minimized for minimum switching loss. Proper layout of the components to minimize high-frequency current path loop (see [Figure 25](#)) is important to prevent electrical and magnetic field radiation and high-frequency resonant problems. The following procedure shows a PCB layout priority list for proper layout. Layout PCB according to this specific order is essential.

1. Place the input capacitor as close as possible to the supply and ground connections of the switching MOSFET and use shortest copper trace connection. These parts should be placed on the same layer of PCB instead of on different layers and using vias to make this connection.
2. The IC should be placed close to the gate terminals of the switching MOSFET and keep the gate drive signal traces short for a clean MOSFET drive. The IC can be placed on the other side of the PCB of switching MOSFETs.
3. Place the inductor input terminal as close as possible to the output terminal of the switching MOSFET. Minimize the copper area of this trace to lower electrical and magnetic field radiation but make the trace wide enough to carry the charging current. Do not use multiple layers in parallel for this connection. Minimize parasitic capacitance from this area to any other trace or plane.
4. Place the charging current-sensing resistor right next to the inductor output. Route the sense leads connected across the sensing resistor back to the IC in same layer, close to each other (minimize loop area) and do not route the sense leads through a high-current path (see [Figure 26](#) for Kelvin connection for best current accuracy). Place the decoupling capacitor on these traces next to the IC.
5. Place the output capacitor next to the sensing resistor output and ground
6. Output capacitor ground connections must be tied to the same copper that connects to the input capacitor ground before connecting to system ground.
7. Use a single ground connection to tie charger power ground to charger analog ground. Use analog ground copper pour just beneath the IC, but avoid power pins to reduce inductive and capacitive noise coupling.
8. Route analog ground separately from power ground. Connect analog ground and connect power ground separately. Connect analog ground and power ground together, using power pad as the single ground connection point, or using a 0- Ω resistor to tie analog ground to power ground (power pad should tie to analog ground in this case if possible).
9. Place the decoupling capacitors next to the IC pins and make trace connection as short as possible.
10. It is critical that the exposed power pad on the backside of the IC package be soldered to the PCB ground. Ensure that there are sufficient thermal vias directly under the IC, connecting to the ground plane on the other layers.
11. The via size and number should be enough for a given current path.

See the EVM design for the recommended component placement with trace and via locations. For the QFN information, see [SCBA017](#) and [SLUA271](#).

Layout Guidelines (continued)

To prevent unintentional charger shut down in normal operation, MOSFET $R_{DS(on)}$ selection and PCB layout is very important. Figure 23 shows a improvement PCB layout example and its equivalent circuit. In this layout, the system current path and charger input current path is not separated, as a result, the system current causes voltage drop in the PCB copper and is sensed by the IC. The worst layout is when a system current pull point is after charger input; as a result all system current voltage drops are counted into overcurrent protection comparator. The worst case for IC is when the total system current and charger input current sum equals the DPM current. When the system pulls more current, the charger IC tries to regulate the R_{AC} current as a constant current by reducing the charging current.

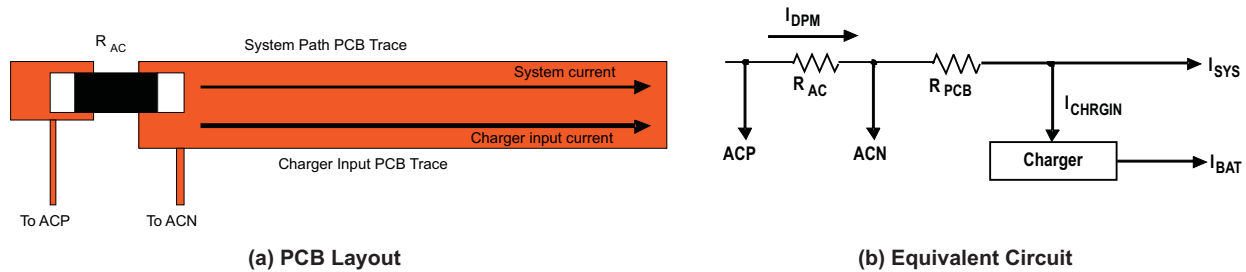

Figure 23. Improvement PCB Layout Example

Figure 24 shows the optimized PCB layout example. The system current path and charge input current path is separated, and as a result, the IC only senses charger input current caused PCB voltage drop and minimized the possibility of unintentional charger shutdown in normal operation. This also makes PCB layout easier for high system current application.

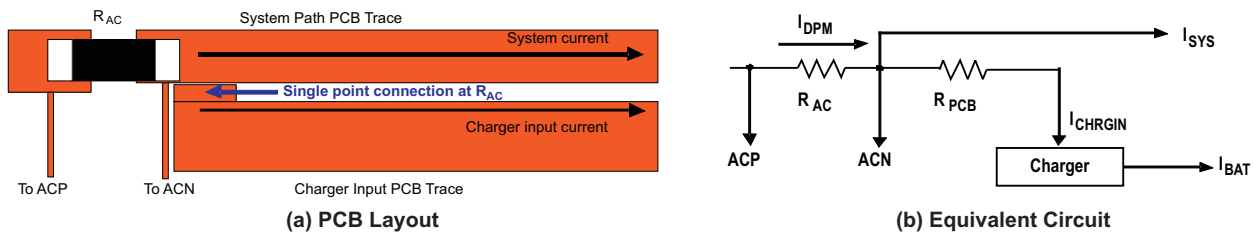

Figure 24. Optimized PCB Layout Example

The total voltage drop sensed by IC can be expressed as the following equation:

$$V_{top} = R_{AC} \times I_{DPM} + R_{PCB} \times (I_{CHRGIN} + (I_{DPM} - I_{CHRGIN}) \times k) + R_{DS(on)} \times I_{PEAK}$$

where

- R_{AC} is the AC adapter current sensing resistance.
- I_{DPM} is the DPM current set point.
- R_{PCB} is the PCB trace equivalent resistance.
- I_{CHRGIN} is the charger input current.
- k is the PCB factor.
- $R_{DS(on)}$ is the high-side MOSFET turnon resistance.
- I_{PEAK} is the peak current of inductor.

(15)

Here, the PCB factor $k = 0$ means the best layout shown in Figure 24, where the PCB trace only goes through charger input current, while $k = 1$ means the worst layout shown in Figure 23, where the PCB trace goes through all the DPM current. The total voltage drop must be below the high-side short-circuit protection threshold to prevent unintentional charger shutdown in normal operation.

Layout Guidelines (continued)

The low-side MOSFET short circuit voltage drop threshold can be adjusted through SMBus command. ChargeOption() bit [7] = 0, 1 sets the low-side threshold, 135 mV and 230 mV, respectively. The high-side MOSFET short circuit voltage drop threshold can be adjusted through SMBus command. ChargeOption() bit [8] = 0, 1 disables the function and set the threshold, 750 mV, respectively. For a fixed PCB layout, host should set proper short-circuit protection threshold level to prevent unintentional charger shutdown in normal operation.

12.2 Layout Example

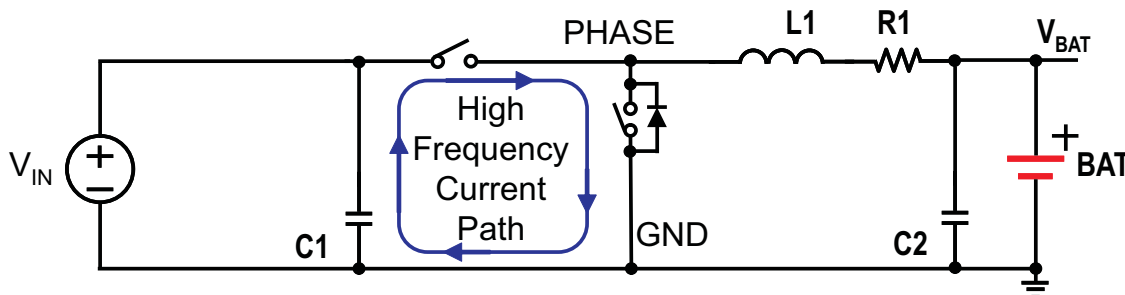

Figure 25. High-Frequency Current Path

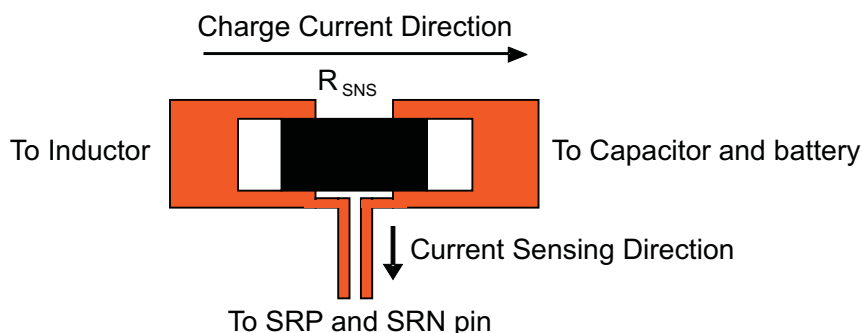

Figure 26. Sensing Resistor PCB Layout

13 Device and Documentation Support

13.1 Device Support

13.1.1 Third-Party Products Disclaimer

TI'S PUBLICATION OF INFORMATION REGARDING THIRD-PARTY PRODUCTS OR SERVICES DOES NOT CONSTITUTE AN ENDORSEMENT REGARDING THE SUITABILITY OF SUCH PRODUCTS OR SERVICES OR A WARRANTY, REPRESENTATION OR ENDORSEMENT OF SUCH PRODUCTS OR SERVICES, EITHER ALONE OR IN COMBINATION WITH ANY TI PRODUCT OR SERVICE.

13.2 Documentation Support

13.2.1 Related Documentation

For related documentation, see the following:

Application Report *Quad Flatpack No-Lead Logic Packages*, [SCBA017](#)

Application Report *QFN/SON PCB Attachment*, [SLUA271](#)

13.3 Trademarks

PowerPAD is a trademark of Texas Instruments.

Intel is a registered trademark of Intel.

All other trademarks are the property of their respective owners.

13.4 Electrostatic Discharge Caution



These devices have limited built-in ESD protection. The leads should be shorted together or the device placed in conductive foam during storage or handling to prevent electrostatic damage to the MOS gates.

13.5 Glossary

[SLYZ022](#) — *TI Glossary*.

This glossary lists and explains terms, acronyms, and definitions.

14 Mechanical, Packaging, and Orderable Information

The following pages include mechanical, packaging, and orderable information. This information is the most current data available for the designated devices. This data is subject to change without notice and revision of this document. For browser-based versions of this data sheet, refer to the left-hand navigation.

PACKAGING INFORMATION

Orderable Device	Status (1)	Package Type	Package Drawing	Pins	Package Qty	Eco Plan (2)	Lead/Ball Finish (6)	MSL Peak Temp (3)	Op Temp (°C)	Device Marking (4/5)	Samples
BQ24735RGRR	ACTIVE	VQFN	RGR	20	3000	Green (RoHS & no Sb/Br)	CU NIPDAU	Level-2-260C-1 YEAR	-40 to 85	BQ735	Samples
BQ24735RGRT	ACTIVE	VQFN	RGR	20	250	Green (RoHS & no Sb/Br)	CU NIPDAU	Level-2-260C-1 YEAR	-40 to 85	BQ735	Samples
HPA02196RGRR	ACTIVE	VQFN	RGR	20	3000	Green (RoHS & no Sb/Br)	CU NIPDAU	Level-2-260C-1 YEAR	-40 to 85	BQ735	Samples

(1) The marketing status values are defined as follows:

ACTIVE: Product device recommended for new designs.

LIFEBUY: TI has announced that the device will be discontinued, and a lifetime-buy period is in effect.

NRND: Not recommended for new designs. Device is in production to support existing customers, but TI does not recommend using this part in a new design.

PREVIEW: Device has been announced but is not in production. Samples may or may not be available.

OBsolete: TI has discontinued the production of the device.

(2) Eco Plan - The planned eco-friendly classification: Pb-Free (RoHS), Pb-Free (RoHS Exempt), or Green (RoHS & no Sb/Br) - please check <http://www.ti.com/productcontent> for the latest availability information and additional product content details.

TBD: The Pb-Free/Green conversion plan has not been defined.

Pb-Free (RoHS): TI's terms "Lead-Free" or "Pb-Free" mean semiconductor products that are compatible with the current RoHS requirements for all 6 substances, including the requirement that lead not exceed 0.1% by weight in homogeneous materials. Where designed to be soldered at high temperatures, TI Pb-Free products are suitable for use in specified lead-free processes.

Pb-Free (RoHS Exempt): This component has a RoHS exemption for either 1) lead-based flip-chip solder bumps used between the die and package, or 2) lead-based die adhesive used between the die and leadframe. The component is otherwise considered Pb-Free (RoHS compatible) as defined above.

Green (RoHS & no Sb/Br): TI defines "Green" to mean Pb-Free (RoHS compatible), and free of Bromine (Br) and Antimony (Sb) based flame retardants (Br or Sb do not exceed 0.1% by weight in homogeneous material)

(3) MSL, Peak Temp. - The Moisture Sensitivity Level rating according to the JEDEC industry standard classifications, and peak solder temperature.

(4) There may be additional marking, which relates to the logo, the lot trace code information, or the environmental category on the device.

(5) Multiple Device Markings will be inside parentheses. Only one Device Marking contained in parentheses and separated by a "~" will appear on a device. If a line is indented then it is a continuation of the previous line and the two combined represent the entire Device Marking for that device.

(6) Lead/Ball Finish - Orderable Devices may have multiple material finish options. Finish options are separated by a vertical ruled line. Lead/Ball Finish values may wrap to two lines if the finish value exceeds the maximum column width.

Important Information and Disclaimer: The information provided on this page represents TI's knowledge and belief as of the date that it is provided. TI bases its knowledge and belief on information provided by third parties, and makes no representation or warranty as to the accuracy of such information. Efforts are underway to better integrate information from third parties. TI has taken and

continues to take reasonable steps to provide representative and accurate information but may not have conducted destructive testing or chemical analysis on incoming materials and chemicals. TI and TI suppliers consider certain information to be proprietary, and thus CAS numbers and other limited information may not be available for release.

In no event shall TI's liability arising out of such information exceed the total purchase price of the TI part(s) at issue in this document sold by TI to Customer on an annual basis.

TAPE AND REEL INFORMATION

QUADRANT ASSIGNMENTS FOR PIN 1 ORIENTATION IN TAPE

*All dimensions are nominal

Device	Package Type	Package Drawing	Pins	SPQ	Reel Diameter (mm)	Reel Width W1 (mm)	A0 (mm)	B0 (mm)	K0 (mm)	P1 (mm)	W (mm)	Pin1 Quadrant
BQ24735RGRR	VQFN	RGR	20	3000	330.0	12.4	3.8	3.8	1.1	8.0	12.0	Q1
BQ24735RGRR	VQFN	RGR	20	3000	330.0	12.4	3.75	3.75	1.15	8.0	12.0	Q1
BQ24735RGRT	VQFN	RGR	20	250	180.0	12.5	3.8	3.8	1.1	8.0	12.0	Q1
BQ24735RGRT	VQFN	RGR	20	250	180.0	12.4	3.75	3.75	1.15	8.0	12.0	Q1

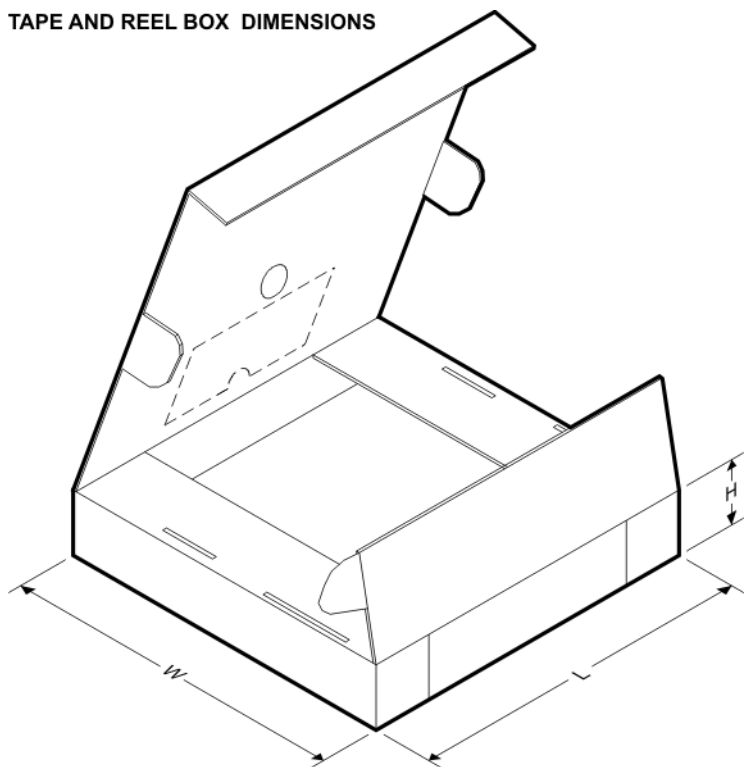
TAPE AND REEL BOX DIMENSIONS

*All dimensions are nominal

Device	Package Type	Package Drawing	Pins	SPQ	Length (mm)	Width (mm)	Height (mm)
BQ24735RGRR	VQFN	RGR	20	3000	338.0	355.0	50.0
BQ24735RGRR	VQFN	RGR	20	3000	552.0	367.0	36.0
BQ24735RGRT	VQFN	RGR	20	250	338.0	355.0	50.0
BQ24735RGRT	VQFN	RGR	20	250	552.0	185.0	36.0

RGR (S-PVQFN-N20)

PLASTIC QUAD FLATPACK NO-LEAD

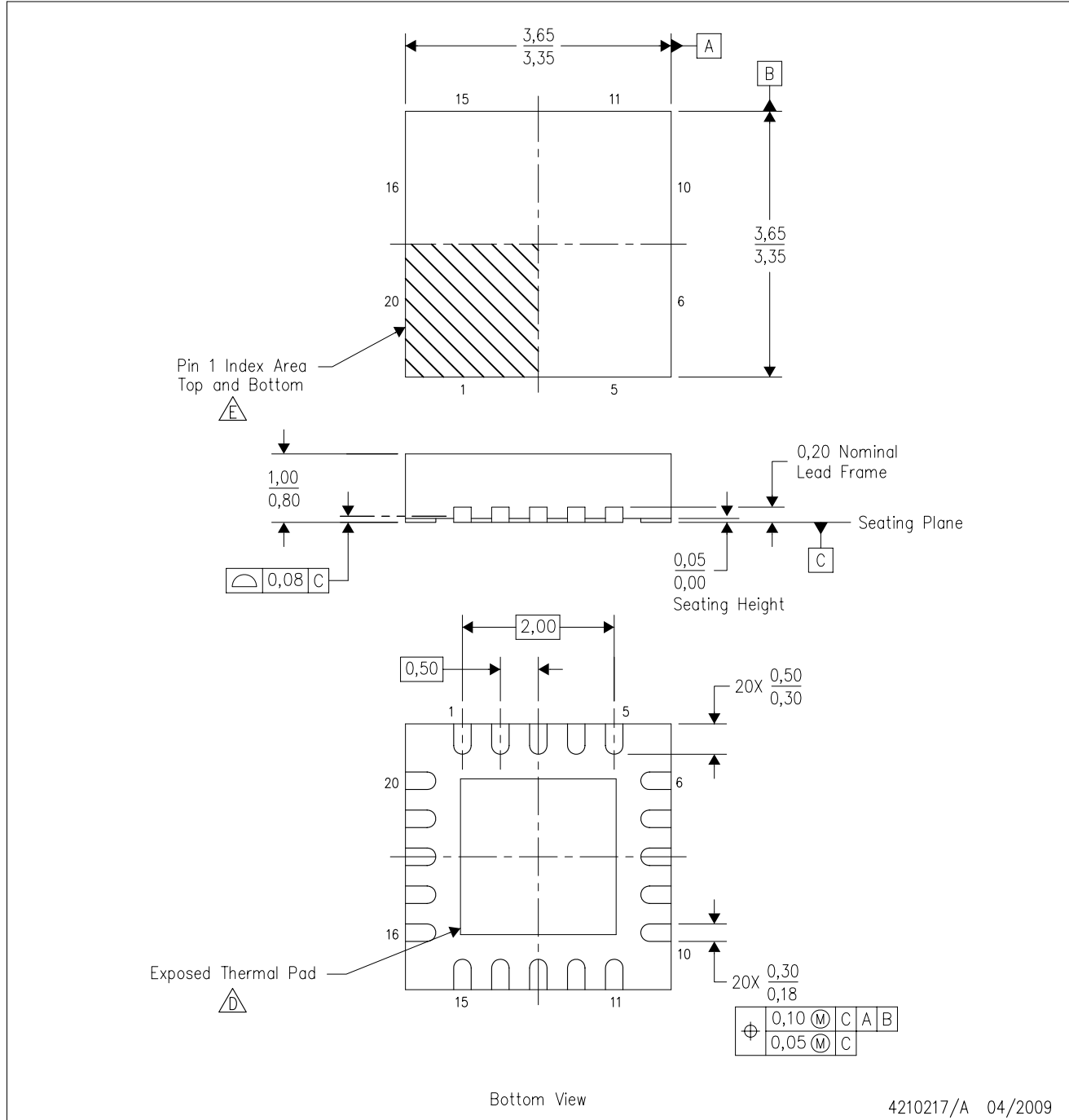

4210217/A 04/2009

- NOTES:
- A. All linear dimensions are in millimeters. Dimensioning and tolerancing per ASME Y14.5M-1994.
 - B. This drawing is subject to change without notice.
 - C. QFN (Quad Flatpack No-Lead) package configuration.
 - The package thermal pad must be soldered to the board for thermal and mechanical performance. See the Product Data Sheet for details regarding the exposed thermal pad dimensions.
 - Pin 1 identifiers are located on both top and bottom of the package and within the zone indicated. The Pin 1 identifiers are either a molded, marked, or metal feature.

THERMAL PAD MECHANICAL DATA

RGR (S-PVQFN-N20)

PLASTIC QUAD FLATPACK NO-LEAD

THERMAL INFORMATION

This package incorporates an exposed thermal pad that is designed to be attached directly to an external heatsink. The thermal pad must be soldered directly to the printed circuit board (PCB). After soldering, the PCB can be used as a heatsink. In addition, through the use of thermal vias, the thermal pad can be attached directly to the appropriate copper plane shown in the electrical schematic for the device, or alternatively, can be attached to a special heatsink structure designed into the PCB. This design optimizes the heat transfer from the integrated circuit (IC).

For information on the Quad Flatpack No-Lead (QFN) package and its advantages, refer to Application Report, QFN/SON PCB Attachment, Texas Instruments Literature No. SLUA271. This document is available at www.ti.com.

The exposed thermal pad dimensions for this package are shown in the following illustration.

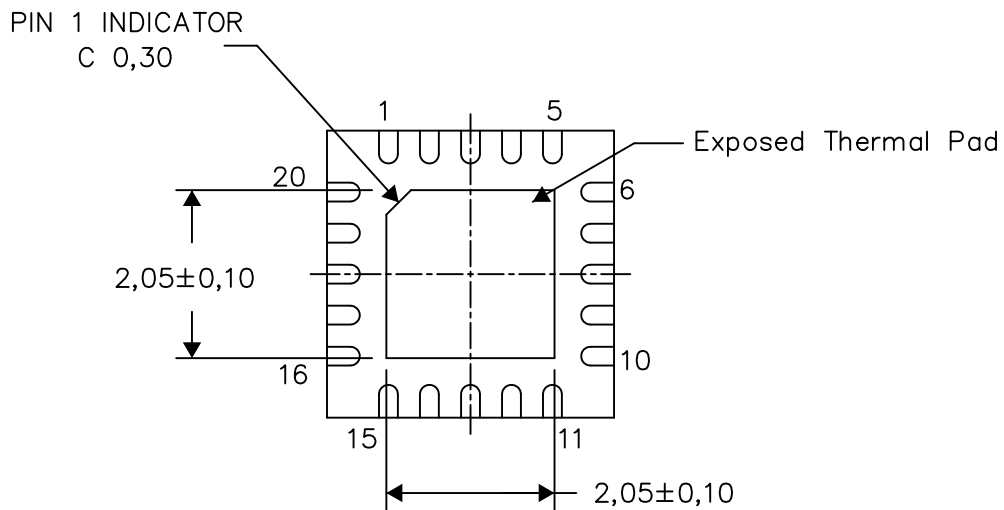

Bottom View

Exposed Thermal Pad Dimensions

4210218/E 04/14

NOTE: All linear dimensions are in millimeters

RGR (S-PVQFN-N20)

PLASTIC QUAD FLATPACK NO-LEAD

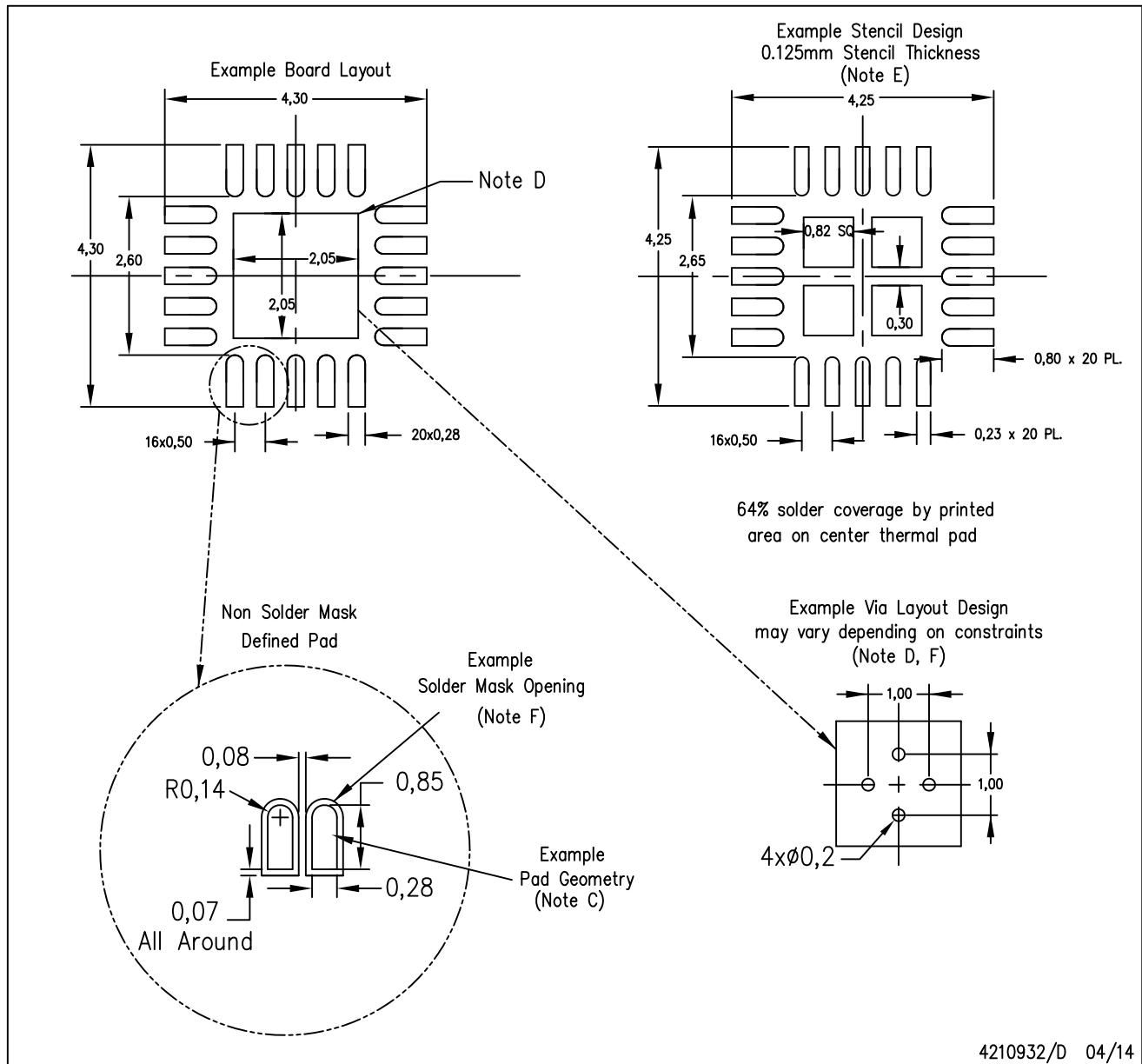

- NOTES:
- All linear dimensions are in millimeters.
 - This drawing is subject to change without notice.
 - Publication IPC-7351 is recommended for alternate designs.
 - This package is designed to be soldered to a thermal pad on the board. Refer to Application Note, Quad Flat-Pack QFN/SON PCB Attachment, Texas Instruments Literature No. SLUA271, and also the Product Data Sheets for specific thermal information, via requirements, and recommended board layout. These documents are available at www.ti.com <<http://www.ti.com>>.
 - Laser cutting apertures with trapezoidal walls and also rounding corners will offer better paste release. Customers should contact their board assembly site for stencil design recommendations. Refer to IPC 7525 for stencil design considerations.
 - Customers should contact their board fabrication site for minimum solder mask web tolerances between signal pads.

IMPORTANT NOTICE

Texas Instruments Incorporated (TI) reserves the right to make corrections, enhancements, improvements and other changes to its semiconductor products and services per JESD46, latest issue, and to discontinue any product or service per JESD48, latest issue. Buyers should obtain the latest relevant information before placing orders and should verify that such information is current and complete.

TI's published terms of sale for semiconductor products (<http://www.ti.com/sc/docs/stdterms.htm>) apply to the sale of packaged integrated circuit products that TI has qualified and released to market. Additional terms may apply to the use or sale of other types of TI products and services.

Reproduction of significant portions of TI information in TI data sheets is permissible only if reproduction is without alteration and is accompanied by all associated warranties, conditions, limitations, and notices. TI is not responsible or liable for such reproduced documentation. Information of third parties may be subject to additional restrictions. Resale of TI products or services with statements different from or beyond the parameters stated by TI for that product or service voids all express and any implied warranties for the associated TI product or service and is an unfair and deceptive business practice. TI is not responsible or liable for any such statements.

Buyers and others who are developing systems that incorporate TI products (collectively, "Designers") understand and agree that Designers remain responsible for using their independent analysis, evaluation and judgment in designing their applications and that Designers have full and exclusive responsibility to assure the safety of Designers' applications and compliance of their applications (and of all TI products used in or for Designers' applications) with all applicable regulations, laws and other applicable requirements. Designer represents that, with respect to their applications, Designer has all the necessary expertise to create and implement safeguards that (1) anticipate dangerous consequences of failures, (2) monitor failures and their consequences, and (3) lessen the likelihood of failures that might cause harm and take appropriate actions. Designer agrees that prior to using or distributing any applications that include TI products, Designer will thoroughly test such applications and the functionality of such TI products as used in such applications.

TI's provision of technical, application or other design advice, quality characterization, reliability data or other services or information, including, but not limited to, reference designs and materials relating to evaluation modules, (collectively, "TI Resources") are intended to assist designers who are developing applications that incorporate TI products; by downloading, accessing or using TI Resources in any way, Designer (individually or, if Designer is acting on behalf of a company, Designer's company) agrees to use any particular TI Resource solely for this purpose and subject to the terms of this Notice.

TI's provision of TI Resources does not expand or otherwise alter TI's applicable published warranties or warranty disclaimers for TI products, and no additional obligations or liabilities arise from TI providing such TI Resources. TI reserves the right to make corrections, enhancements, improvements and other changes to its TI Resources. TI has not conducted any testing other than that specifically described in the published documentation for a particular TI Resource.

Designer is authorized to use, copy and modify any individual TI Resource only in connection with the development of applications that include the TI product(s) identified in such TI Resource. NO OTHER LICENSE, EXPRESS OR IMPLIED, BY ESTOPPEL OR OTHERWISE TO ANY OTHER TI INTELLECTUAL PROPERTY RIGHT, AND NO LICENSE TO ANY TECHNOLOGY OR INTELLECTUAL PROPERTY RIGHT OF TI OR ANY THIRD PARTY IS GRANTED HEREIN, including but not limited to any patent right, copyright, mask work right, or other intellectual property right relating to any combination, machine, or process in which TI products or services are used. Information regarding or referencing third-party products or services does not constitute a license to use such products or services, or a warranty or endorsement thereof. Use of TI Resources may require a license from a third party under the patents or other intellectual property of the third party, or a license from TI under the patents or other intellectual property of TI.

TI RESOURCES ARE PROVIDED "AS IS" AND WITH ALL FAULTS. TI DISCLAIMS ALL OTHER WARRANTIES OR REPRESENTATIONS, EXPRESS OR IMPLIED, REGARDING RESOURCES OR USE THEREOF, INCLUDING BUT NOT LIMITED TO ACCURACY OR COMPLETENESS, TITLE, ANY EPIDEMIC FAILURE WARRANTY AND ANY IMPLIED WARRANTIES OF MERCHANTABILITY, FITNESS FOR A PARTICULAR PURPOSE, AND NON-INFRINGEMENT OF ANY THIRD PARTY INTELLECTUAL PROPERTY RIGHTS. TI SHALL NOT BE LIABLE FOR AND SHALL NOT DEFEND OR INDEMNIFY DESIGNER AGAINST ANY CLAIM, INCLUDING BUT NOT LIMITED TO ANY INFRINGEMENT CLAIM THAT RELATES TO OR IS BASED ON ANY COMBINATION OF PRODUCTS EVEN IF DESCRIBED IN TI RESOURCES OR OTHERWISE. IN NO EVENT SHALL TI BE LIABLE FOR ANY ACTUAL, DIRECT, SPECIAL, COLLATERAL, INDIRECT, PUNITIVE, INCIDENTAL, CONSEQUENTIAL OR EXEMPLARY DAMAGES IN CONNECTION WITH OR ARISING OUT OF TI RESOURCES OR USE THEREOF, AND REGARDLESS OF WHETHER TI HAS BEEN ADVISED OF THE POSSIBILITY OF SUCH DAMAGES.

Unless TI has explicitly designated an individual product as meeting the requirements of a particular industry standard (e.g., ISO/TS 16949 and ISO 26262), TI is not responsible for any failure to meet such industry standard requirements.

Where TI specifically promotes products as facilitating functional safety or as compliant with industry functional safety standards, such products are intended to help enable customers to design and create their own applications that meet applicable functional safety standards and requirements. Using products in an application does not by itself establish any safety features in the application. Designers must ensure compliance with safety-related requirements and standards applicable to their applications. Designer may not use any TI products in life-critical medical equipment unless authorized officers of the parties have executed a special contract specifically governing such use. Life-critical medical equipment is medical equipment where failure of such equipment would cause serious bodily injury or death (e.g., life support, pacemakers, defibrillators, heart pumps, neurostimulators, and implantables). Such equipment includes, without limitation, all medical devices identified by the U.S. Food and Drug Administration as Class III devices and equivalent classifications outside the U.S.

TI may expressly designate certain products as completing a particular qualification (e.g., Q100, Military Grade, or Enhanced Product). Designers agree that it has the necessary expertise to select the product with the appropriate qualification designation for their applications and that proper product selection is at Designers' own risk. Designers are solely responsible for compliance with all legal and regulatory requirements in connection with such selection.

Designer will fully indemnify TI and its representatives against any damages, costs, losses, and/or liabilities arising out of Designer's non-compliance with the terms and provisions of this Notice.

Looking for pricing, stock, or lifecycle information?

Click below to explore more details on WIN SOURCE:

 [View BQ24735RGRT](#) on WIN SOURCE

 [Texas Instruments](#) Information

Optimize Your Supply Chain with WIN SOURCE Solutions

-  Global Sourcing Solution
-  Obsolete Management
-  Cost Control Management
-  Shortage Management
-  Alternative Solution
-  Excess Inventory Management