



THE DATASHEET OF BQ24278RGER



2.5A, Single Input, Single Cell Switchmode Li-Ion BATTERY CHARGER with Power Path Management

 Check for Samples: [bq24278](#)

FEATURES

- High-Efficiency Switch Mode Charger with Separate Power Path Control
 - Instantly Startup System from a Deeply Discharged Battery or No Battery
- 20V input rating, with 10.5V Over-Voltage Protection (OVP)
- Integrated FETs for Up to 2.5A Charge Rate
- Highly Integrated Battery N-Channel MOSFET Controller for Power Path Management
- Safe and accurate Battery Management Functions
 - 0.5% Battery Regulation Accuracy
 - 10% Charge Current Accuracy
- Voltage-based, NTC Monitoring Input (TS)
 - Standard Temp Range

- Thermal Regulation Protection for Output Current Control
- Low Battery Leakage Current, BAT Short-Circuit Protection
- Soft-Start feature to reduce inrush current
- Thermal Shutdown and Protection
- Available in small 49-ball WCSP or QFN-24 packages

APPLICATIONS

- Handheld Products
- Portable Media Players
- Portable Equipment
- Netbook and Portable Internet Devices

APPLICATION SCHEMATIC

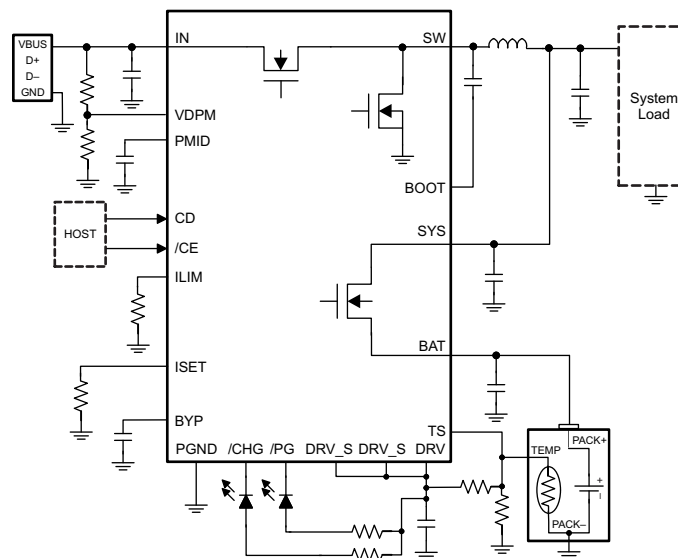

DESCRIPTION

The bq24278 highly integrated single cell Li-Ion battery charger and system power path management device targeted for space-limited, portable applications with high capacity batteries. The single cell charger operates from a dedicated charging source such as an AC adapter or Wireless Power.



Please be aware that an important notice concerning availability, standard warranty, and use in critical applications of Texas Instruments semiconductor products and disclaimers thereto appears at the end of this data sheet.

bq24278

SLUSB04 –JUNE 2012

www.ti.com

These devices have limited built-in ESD protection. The leads should be shorted together or the device placed in conductive foam during storage or handling to prevent electrostatic damage to the MOS gates.

DESCRIPTION (CONTINUED)

The power path management feature allows the bq24278 to power the system from a high efficiency DC to DC converter while simultaneously and independently charging the battery. The charger monitors the battery current at all times and reduces the charge current when the system load requires current above the input current limit. This allows for proper charge termination and timer operation. The system voltage is regulated to the battery voltage but will not drop below 3.5V. This minimum system voltage support enables the system to run with a defective or absent battery pack and enables instant system turn-on even with a totally discharged battery or no battery. The power-path management architecture also permits the battery to supplement the system current requirements when the adapter cannot deliver the peak system currents. This enables the use of a smaller adapter.

The battery is charged in three phases: conditioning, constant current and constant voltage. In all charge phases, an internal control loop monitors the IC junction temperature and reduces the charge current if the internal temperature threshold is exceeded. Additionally, the bq24278 offers a voltage-based battery pack thermistor monitoring input (TS) that monitors battery temperature for safe charging .

ORDERING INFORMATION

PART NUMBER	IN OVP	NTC MONITORING (TS)	JEITA COMPATIBLE	MINIMUM SYSTEM VOLTAGE	PACKAGE
bq24278YFFR	10.5 V	Yes	No	3.5 V	WCSP
bq24278YFFT	10.5 V	Yes	No	3.5 V	WCSP
bq24278RGER	10.5 V	Yes	No	3.5 V	QFN
bq24278RGET	10.5 V	Yes	No	3.5 V	QFN

ABSOLUTE MAXIMUM RATINGS

over operating free-air temperature range (unless otherwise noted)⁽¹⁾

		MIN	MAX	UNIT
Pin voltage range (with respect to VSS)	IN	-2	20	V
	PMID, BYP, BOOT	-0.3	20	V
	SW	-0.7	12	V
	SYS, BAT, BGATE, DRV, $\overline{\text{PG}}$, $\overline{\text{CHG}}$, $\overline{\text{CE}}$, CD, TS, DRV_S, ILIM, ISET, VDPM	-0.3	7	V
BOOT to SW		-0.3	7	V
Output current (continuous)	SW		4.5	A
	SYS		3.5	A
Input current (continuous)	IN		2.75	A
Output sink current	$\overline{\text{PG}}$, $\overline{\text{CHG}}$		10	mA
Operating free-air temperature range		-40	85	°C
Junction temperature, T _J		-40	125	°C
Storage temperature, T _{STG}		-65	150	°C
Lead temperature (soldering, 10 s)			300	°C

- (1) Stresses beyond those listed under absolute maximum ratings may cause permanent damage to the device. These are stress ratings only, and functional operation of the device at these or any other conditions beyond those indicated under recommended operating conditions is not implied. Exposure to absolute-maximum-rated conditions for extended periods may affect device reliability. All voltage values are with respect to the network ground terminal unless otherwise noted.

THERMAL INFORMATION

THERMAL METRIC ⁽¹⁾		bq24278		UNITS
		YFF (48 PINS)	QFN (24 PINS)	
θ_{JA}	Junction-to-ambient thermal resistance	49.8	32.6	°C/W
θ_{JCTop}	Junction-to-case (top) thermal resistance	0.2	30.5	
θ_{JB}	Junction-to-board thermal resistance	1.1	3.3	
Ψ_{JT}	Junction-to-top characterization parameter	1.1	0.4	
Ψ_{JB}	Junction-to-board characterization parameter	6.6	9.3	
θ_{JCbott}	Junction-to-case (bottom) thermal resistance	N/A	2.6	

(1) For more information about traditional and new thermal metrics, see the *IC Package Thermal Metrics* application report, [SPRA953](#).

RECOMMENDED OPERATING CONDITIONS

		MIN	MAX	UNITS
V_{IN}	IN voltage range	4.2	18 ⁽¹⁾	V
	IN operating range	4.2	10	
I_{IN}	Input current IN input		2.5	A
I_{SYS}	Output Current from SW, DC		3	A
I_{BAT}	Charging		2.5	A
	Discharging, using internal battery FET		2.5	
T_J	Operating junction temperature range	0	125	°C

(1) The inherent switching noise voltage spikes should not exceed the absolute maximum rating on either the BOOT or SW pins. A tight layout minimizes switching noise.

ELECTRICAL CHARACTERISTICS

Circuit of [Figure 2](#), $V_{UVLO} < V_{IN} < V_{OVP}$ AND $V_{IN} > V_{BAT} + V_{SLP}$, $T_J = 0^{\circ}\text{C} - 125^{\circ}\text{C}$ and $T_J = 25^{\circ}\text{C}$ for typical values (unless otherwise noted)

PARAMETER	TEST CONDITIONS	MIN	TYP	MAX	UNIT		
I_{IN}	Input quiescent current	$V_{UVLO} < V_{IN} < V_{OVP}$ AND $V_{IN} > V_{BAT} + V_{SLP}$ PWM switching		15	mA		
		$V_{UVLO} < V_{IN} < V_{OVP}$ AND $V_{IN} > V_{BAT} + V_{SLP}$ PWM NOT switching		5			
		0°C < T_J < 85°C, High-Z Mode		175	μA		
$I_{BATLEAK}$	Leakage current from BAT to the supply	0°C < T_J < 85°C, $V_{BAT} = 4.2\text{V}$, $V_{IN} = 0\text{V}$		5	μA		
I_{BAT_HIZ}	Battery discharge current in High Impedance mode (BAT, SW, SYS)	0°C < T_J < 85°C, $V_{BAT} = 4.2\text{V}$, $V_{IN} = 0\text{V}$ or 5V , High-Z Mode		55	μA		
POWER PATH MANAGEMENT							
$V_{SYS(REG)}$	System regulation voltage	$V_{BAT} < V_{MINSYS}$		3.6	3.7	3.82	V
$V_{SYSREGFETOFF}$		Battery FET turned off, Charge disable or termination		4.26	4.33	4.37	
V_{MINSYS}	Minimum system regulation voltage	$V_{BAT} < V_{MINSYS}$, Input current limit or VINDPM active		3.4	3.5	3.62	V
V_{BSUP1}	Enter supplement mode threshold	$V_{BAT} > 2.5\text{V}$			$V_{BAT} - 40\text{mV}$		V
V_{BSUP2}	Exit supplement mode threshold	$V_{BAT} > 2.5\text{V}$			$V_{BAT} - 10\text{mV}$		V
$I_{LIM(Discharge)}$	Current limit, discharge or supplement mode	Current monitored in internal FET only			7		A
$t_{DGL(SC1)}$	Deglint time, OUT short circuit during discharge or supplement mode	Measured from $(V_{BAT} - V_{SYS}) = 300\text{mV}$ to $V_{BGATE} = (V_{BAT} - 600\text{mV})$			250		μs
$t_{REC(SC1)}$	Recovery time, OUT short circuit during discharge or supplement mode				60		ms
	Battery range for BGATE operation	2.5		4.5			V

bq24278

SLUSB04 –JUNE 2012

www.ti.com

ELECTRICAL CHARACTERISTICS (continued)

Circuit of Figure 2, $V_{UVLO} < V_{IN} < V_{OVP}$ AND $V_{IN} > V_{BAT} + V_{SLP}$, $T_J = 0^\circ\text{C} - 125^\circ\text{C}$ and $T_J = 25^\circ\text{C}$ for typical values (unless otherwise noted)

PARAMETER		TEST CONDITIONS		MIN	TYP	MAX	UNIT
BATTERY CHARGER							
$R_{ON(BAT-SYS)}$	Internal battery charger MOSFET on-resistance	Measured from BAT to SYS, $V_{BAT} = 4.2\text{ V}$	YFF pkg RGE pkg		37 50	57 70	mΩ
V_{BATREG}	Battery regulation voltage	$T_A = 25^\circ\text{C}$ $V_{WARM} < V_{TS} < V_{COOL}$ $T_A = 25^\circ\text{C}$ $V_{HOT} < V_{TS} < V_{WARM}$		4.179	4.2	4.221	V
				4.160	4.2	4.24	
				4.04	4.06	4.08	
				4.02	4.06	4.1	
I_{CHARGE}	Charge current programmable range	$I_{CHARGE} = \frac{K_{ISET}}{R_{ISET}}$		550		2500	mA
K_{ISET}	Programmable fast charge current factor	$T_A = 0^\circ\text{C}$ to 125°C , $V_{WARM} < V_{TS} < V_{COOL}$ $T_A = 0^\circ\text{C}$ to 125°C , $V_{COLD} < V_{TS} < V_{COOL}$		400	490	560	AΩ
				225	245	270	
$V_{BATSHRT}$	Battery short threshold	V_{BAT} Rising		2.9	3.0	3.1	V
$V_{BATSHRTHYS}$	Battery short threshold hysteresis	V_{BAT} Falling			100		mV
$I_{BATSHRT}$	Battery short current	$V_{BAT} < V_{BATSHRT}$			50.0		mA
$t_{DGL(BATSHRT)}$	Deglitch time for battery short to fast charge transition				32		ms
I_{TERM}	Termination charge current		$I_{CHARGE} \leq 1\text{ A}$	7	10	11.5	% I_{CHARGE}
			$I_{CHARGE} > 1\text{ A}$	8	10	11	
$t_{DGL(TERM)}$	Deglitch time for charge termination	Both rising and falling, 2-mV over-drive, $t_{RISE}, t_{FALL} = 100\text{ ns}$			32		ms
V_{RCH}	Recharge threshold voltage	Below V_{BATREG}			120		mV
$t_{DGL(RCH)}$	Deglitch time	V_{BAT} falling below V_{RCH} , $t_{FALL} = 100\text{ ns}$			32		ms
I_{DETECT}	Battery detection current before charge done (sink current)				2.5		mA
t_{DETECT}	Battery detection time				250		ms
INPUT PROTECTION							
I_{INLIM}	Maximum input current limit programmable range for IN input	$I_{INLIM} = \frac{K_{ILIM}}{R_{ILIM}}$		1000		2500	mA
K_{ILIM}	Maximum input current factor for IN input			238	251	264	AΩ
$V_{IN_DPM_IN}$	V_{IN_DPM} threshold programmable range for IN Input			4.2		10	V
	VDPM threshold			1.18	1.2	1.22	V
V_{DRV}	Internal bias regulator voltage			5	5.2	5.45	V
I_{DRV}	DRV Output current			10			mA
V_{DO_DRV}	DRV Dropout voltage ($V_{IN} - V_{DRV}$)	$I_{IN} = 1\text{ A}$, $V_{IN} = 5\text{ V}$, $I_{DRV} = 10\text{ mA}$				450	mV
V_{UVLO}	IC active threshold voltage	V_{IN} rising		3.6	3.8	4.0	V
V_{UVLO_HYS}	IC active hysteresis	V_{IN} falling from above V_{UVLO}			150		mV
V_{SLP}	Sleep-mode entry threshold, $V_{IN} - V_{BAT}$	$2.0\text{ V} \leq V_{BAT} \leq V_{OREG}$, V_{IN} falling		0	40	100	mV
V_{SLP_EXIT}	Sleep-mode exit hysteresis	$2.0\text{ V} \leq V_{BAT} \leq V_{OREG}$		40	100	160	mV
	Deglitch time for supply rising above $V_{SLP} + V_{SLP_EXIT}$	Rising voltage, 2-mV over drive, $t_{RISE} = 100\text{ ns}$			30		ms
V_{OVP}	Input supply OVP threshold voltage	IN, V_{IN} Rising		10.3	10.5	10.7	V
$V_{OVP(HYS)}$	V_{OVP} hysteresis	Supply falling from V_{OVP}			100		mV
V_{BOVP}	Battery OVP threshold voltage	V_{BAT} threshold over V_{OREG} to turn off charger during charge		$1.025 \times V_{BATREG}$	$1.05 \times V_{BATREG}$	$1.075 \times V_{BATREG}$	V
	V_{BOVP} hysteresis	Lower limit for V_{BAT} falling from above V_{BOVP}			1		% of V_{BATREG}
$V_{BATUVLO}$	Battery UVLO threshold voltage				2.5		V
I_{LIMIT}	Cycle by Cycle current limit			4.1	4.9	5.6	A
$T_{SHUTDOWN}$	Thermal shutdown	10C Hysteresis			165		C
T_{REG}	Thermal regulation threshold				120		C
	Safety Timer			324	360	396	min
CE, CD, PG, CHG							
V_{IH}	Input high threshold			1.3			V
V_{IL}	Input low threshold					0.4	V
I_{IH}	High-level leakage current	$V_{CHG} = V_{PG} = 5\text{ V}$				1	μA
V_{OL}	Low-level output saturation voltage	$I_O = 10\text{ mA}$, sink current				0.4	V

ELECTRICAL CHARACTERISTICS (continued)

Circuit of [Figure 2](#), $V_{U_{VLO}} < V_{IN} < V_{OVP}$ AND $V_{IN} > V_{BAT} + V_{SLP}$, $T_J = 0^{\circ}\text{C} - 125^{\circ}\text{C}$ and $T_J = 25^{\circ}\text{C}$ for typical values (unless otherwise noted)

PARAMETER		TEST CONDITIONS	MIN	TYP	MAX	UNIT
PWM CONVERTER						
	Internal top reverse blocking MOSFET on-resistance	$I_{IN_LIMIT} = 500 \text{ mA}$, Measured from V_{IN} to PMIDU		95	175	mΩ
	Internal top N-channel Switching MOSFET on-resistance	Measured from PMIDU to SW		100	175	mΩ
	Internal bottom N-channel MOSFET on-resistance	Measured from SW to PGND		65	115	mΩ
f_{OSC}	Oscillator frequency		1.35	1.50	1.65	MHz
D_{MAX}	Maximum duty cycle			95%		
D_{MIN}	Minimum duty cycle		0			
BATTERY-PACK NTC MONITOR						
V_{HOT}	High temperature threshold	V_{TS} falling	29.7	30	30.5	%VDRV
$V_{HYS(HOT)}$	Hysteresis on high threshold	V_{TS} rising		1		
V_{COLD}	Low temperature threshold	V_{TS} rising	59.5	60	60.4	
V_{WARM}	Warm temperature threshold	V_{TS} falling	37.9	38.3	39.6	
$V_{HYS(WARM)}$	Hysteresis on warm threshold	V_{TS} rising		1		
V_{COOL}	Cool temperature threshold	V_{TS} rising	56.0	56.5	56.9	
$V_{HYS(COOL)}$	Hysteresis on cool threshold	V_{TS} falling		1		
$V_{HYS(COLD)}$	Hysteresis on low threshold	V_{TS} falling		1		
TSOFF	TS Disable threshold	V_{TS} rising, 2% V_{DRV} Hysteresis	70		73	
$t_{DGL(TS)}$	Deglitch time on TS change			50		ms

BLOCK DIAGRAM

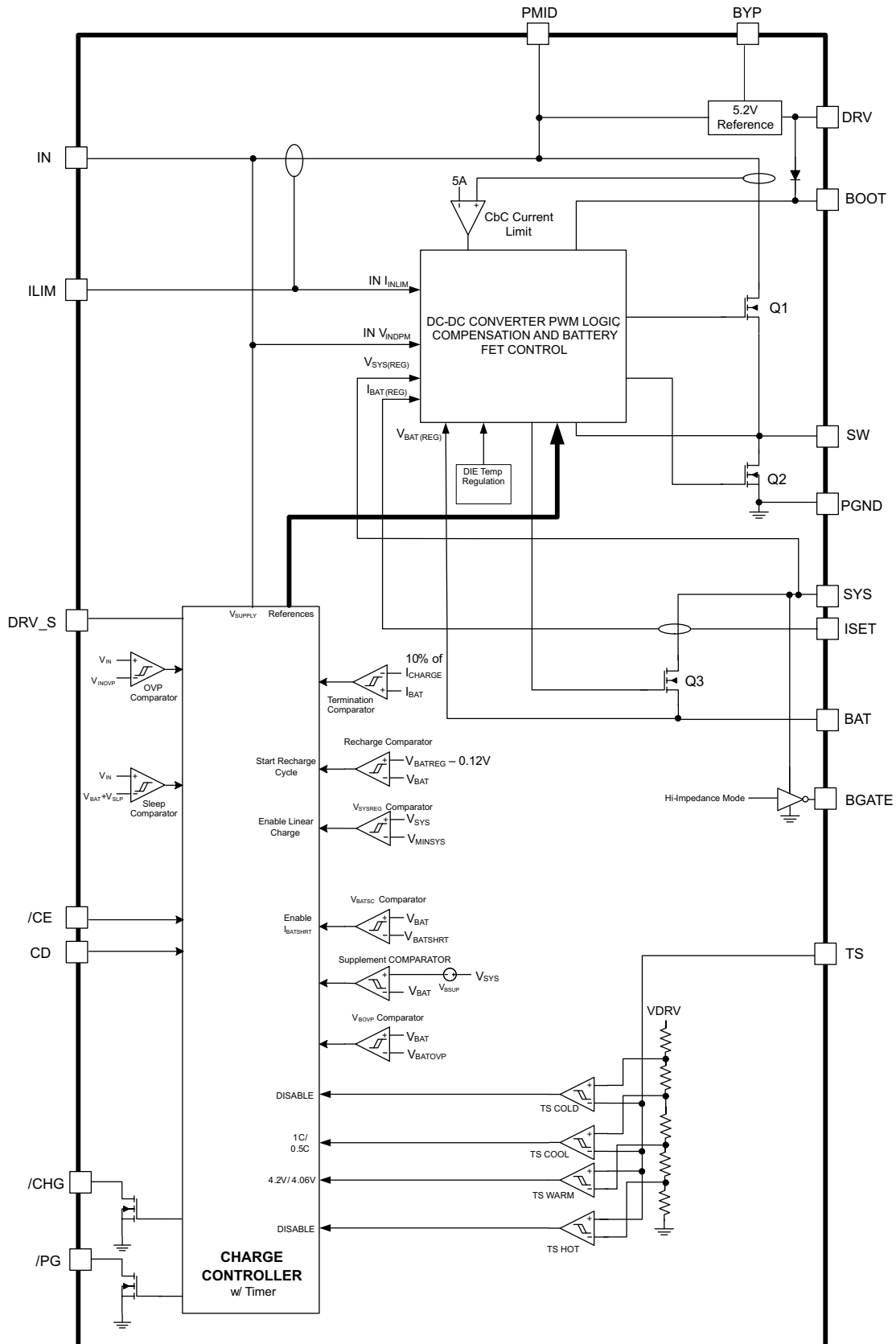

PIN CONFIGURATION

49-BALL WCSP
(TOP VIEW)

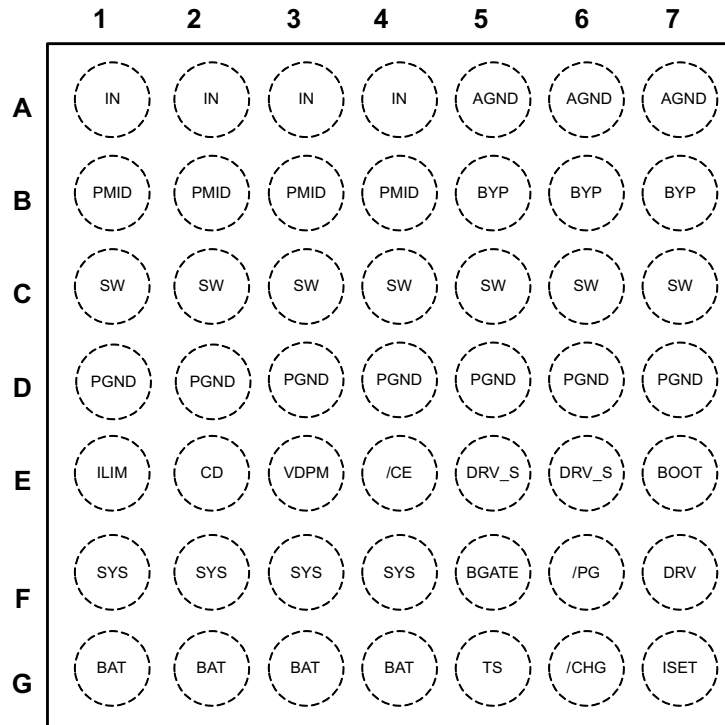

24-PIN QFN
(TOP VIEW)

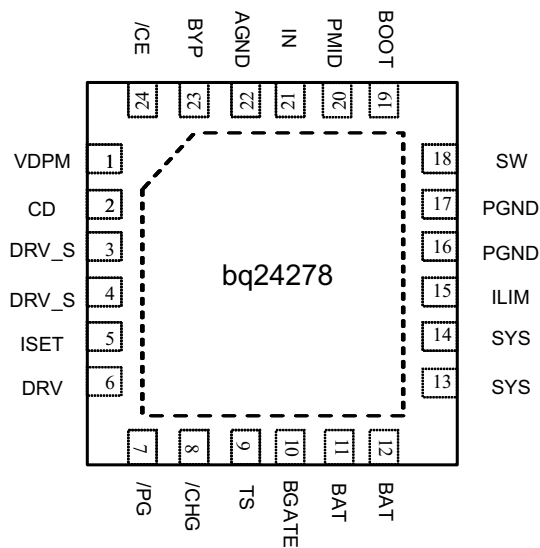

PIN FUNCTIONS

PIN		I/O	DESCRIPTION	
NAME	NUMBER			
YFF	RGE			
IN	A1-A4	21	I	Input power supply. IN is connected to the external DC supply (AC adapter or alternate power source). Bypass IN to PGND with at least a 1µF ceramic capacitor.
AGND	A5-A7	22	I	Ground terminal. Connect to the thermal pad (for QFN only) and the ground plane of the circuit.
PMID	B1-B4	20	O	Reverse Blocking MOSFET and High Side MOSFET Connection Point for High Power Input. Bypass PMID to PGND with at least a 4.7µF ceramic capacitor. Use caution when connecting an external load to PMID. The PMID output is not current limited. Any short on PMID will result in damage to the IC.
BYP	B5-B7	23	O	Bypass for internal supply. Bypass BYP to GND with at least a 0.1µF ceramic capacitor.
SW	C1-C7	18	O	Inductor Connection. Connect to the switched side of the external inductor.
PGND	D1-D7	16, 17	—	Ground terminal for Switching FET. Connect to the thermal pad (for QFN only) and the ground plane of the circuit.
ILIM	E1	15	I	IN Input Current Limit Programming Input. Connect a resistor from ILIM to GND to program the input current limit for IN. The current limit is programmable from 1A to 2.5A.
CD	E2	2	I	IC Hardware Disable Input. Drive CD high to place the bq24278 in high-z mode. Drive CD low for normal operation.
VDPM	E3	1	I	Input DPM Programming Input. Connect a resistor divider from IN to PGND with VDPM connected to the center tap to program the Input Voltage based Dynamic Power Management (VIN_DPM) threshold. The input current is reduced to maintain the supply voltage at VIN_DPM. See the <i>Input Voltage based Dynamic Power Management</i> section for a detailed explanation.
\overline{CE}	E4	24	I	Charge Enable Input. \overline{CE} is used to disable or enable the charge process. A low logic level (0) enables charging and a high logic level (1) disables charging. When charging is disabled, the SYS output remains in regulation, but BAT is disconnected from SYS. Supplement mode is still available if the system load demands cannot be met by the supply.
DRV_S	E5, E6	3, 4	I	Supply for Internal Circuits. Connect DRV_S to DRV directly.
BOOT	E7	19	I	High Side MOSFET Gate Driver Supply. Connect a 0.01µF ceramic capacitor (voltage rating > 10V) from BOOT to SW to supply the gate drive for the high side MOSFETs.
SYS	F1-F4	13,14	I/O	System Voltage Sense and Charger FET Connection. Connect SYS to the system output at the output bulk capacitors. Bypass SYS locally with 1µF.
BGATE	F5	10	O	External Discharge MOSFET Gate Connection. BGATE drives an external P-Channel MOSFET to provide a very low resistance discharge path. Connect BGATE to the gate of the external MOSFET. BGATE is low during supplement mode and when no input is connected.
\overline{PG}	F6	7	I	Power Good Open Drain Output. \overline{PG} is pulled low when a valid supply is connected to IN. A valid supply is between $V_{BAT} + V_{SLP}$ and V_{OVP} . If no supply is connected or the supply is out of this range, \overline{PG} is high impedance.
DRV	F7	6	O	Gate Drive Supply. DRV is the bias supply for the gate drive of the internal MOSFETs. bypass DRV to PGND with a 1µF ceramic capacitor. DRV may be used to drive external loads up to 10mA. DRV is active whenever the input is connected and $V_{SUPPLY} > V_{UVLO}$ and $V_{SUPPLY} > (V_{BAT} + V_{SLP})$
BAT	G1-G4	11, 12	I/O	Battery Connection. Connect to the positive terminal of the battery. Additionally, bypass BAT to GND with a 1µF capacitor.
TS	G5	9	I	Battery Pack NTC Monitor. Connect TS to the center tap of a resistor divider from DRV to GND. The NTC is connected from TS to GND. The TS function in the bq24278 provides 2 thresholds for Hot/ Cold shutoff, with 2 additional thresholds for JEITA compliance. See the <i>NTC Monitor</i> section for more details on operation and selecting the resistor values.
\overline{CHG}	G6	8	O	Charge Status Open Drain Output. \overline{CHG} is pulled low when a charge cycle starts and remains low while charging. \overline{CHG} is high impedance when the charging terminates and when no supply exists. \overline{CHG} does not indicate recharge cycles.
ISET	G7	5	I	Charge Current Programming Input. Connect a resistor from ISET to GND to program the fast charge current. The charge current is programmable from 550mA to 2.5A.
Thermal Pad	—	Pad	—	There is an internal electrical connection between the exposed thermal pad and the VSS pin of the device. The thermal pad must be connected to the same potential as the VSS pin on the printed circuit board. Do not use the thermal pad as the primary ground input for the device. VSS pin must be connected to ground at all times.

TYPICAL APPLICATION CIRCUIT

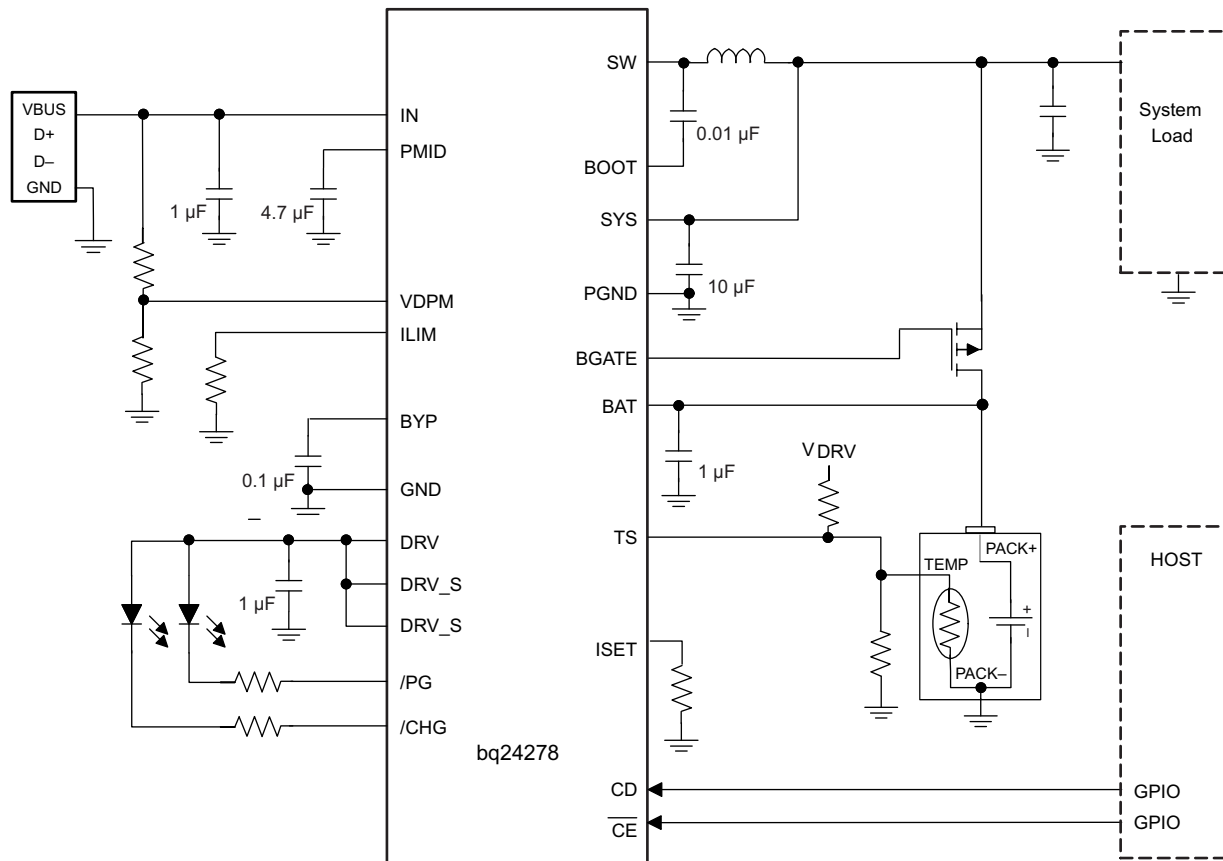

Figure 1. bq24278 Application Circuit, External Discharge FET Connected

bq24278

SLUSB04 – JUNE 2012

www.ti.com

DETAILED DESCRIPTION

The bq24278 is a highly integrated single cell Li-Ion battery charger and system power path management devices targeted for space-limited, portable applications with high capacity batteries. The power path management feature allows the bq24278 to power the system from a high efficiency DC to DC converter while simultaneously and independently charging the battery. The charger monitors the battery current at all times and reduces the charge current when the system load requires current above the input current limit. This allows for proper charge termination and enables the system to run with a defective or absent battery pack. Additionally, this enables instant system turn-on even with a totally discharged battery or no battery. The power-path management architecture also permits the battery to supplement the system current requirements when the adapter cannot deliver the peak system currents. This enables the use of a smaller adapter. The battery is charged in three phases: conditioning, constant current and constant voltage. In all charge phases, an internal control loop monitors the IC junction temperature and reduces the charge current if the internal temperature threshold is exceeded.

Charge Mode Operation

Charge Profile

Charging is done through the internal battery MOSFET. When the battery voltage is above 3.5V, the system output (SYS) is connected to the battery to maximize the charging efficiency. There are 5 loops that influence the charge current; constant current loop (CC), constant voltage loop (CV), thermal regulation loop, minimum system voltage loop (MINSYS) and input voltage dynamic power management loop (V_{IN-DPM}). During the charging process, all five loops are enabled and the dominant one takes control. The bq24278 supports a precision Li-Ion or Li-Polymer charging system for single-cell applications. The minimum system output feature regulates the system voltage to a minimum of $V_{SYS(REG)}$, so that startup is enabled even for a missing or deeply discharged battery. Figure 2 shows a typical charge profile including the minimum system output voltage feature.

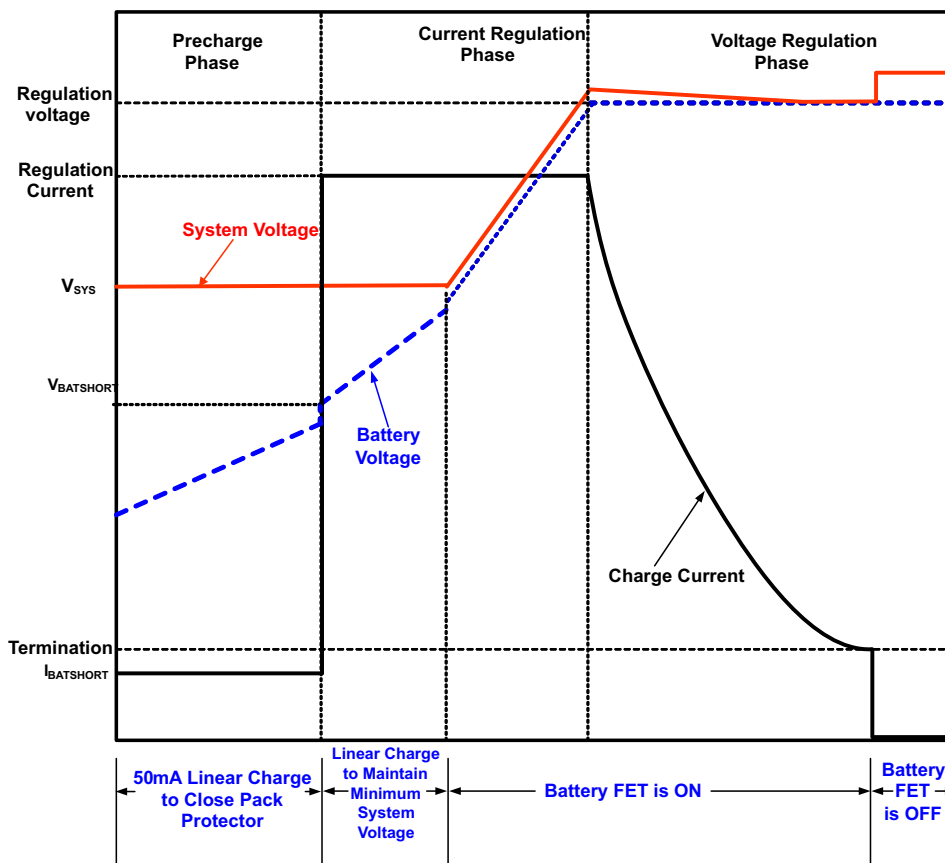

Figure 2. Typical Charging Profile of bq24278

PWM Controller in Charge Mode

The bq24278 provides an integrated, fixed 1.5 MHz frequency voltage-mode controller with to power the system and supply the charge current. The converter is internally compensated and provides enough phase margin for stable operation, allowing the use of small ceramic capacitors with very low ESR.

The bq24278 input scheme prevents battery discharge when the supply voltage is lower than V_{BAT} . The high-side N-MOSFET (Q1) switches to control the power delivered to SYS. The DRV LDO supplies the gate drive for the internal MOSFETs. The high-side MOSFET is supplied by a boot strap circuit with external boot-strap capacitor (BST).

The input is protected from short circuit by a cycle-by-cycle current limit that is sensed through the high-side MOSFET. The threshold is set to a nominal 5-A peak current. The input also utilizes an input current limit that limits the current from the power source.

Battery Charging Process

When the battery is deeply discharged or shorted, the bq24278 applies a 50mA current to charge the battery voltage up to acceptable charging levels. During this time, the battery FET is linearly regulated to maintain the system output regulation at $V_{SYS(REG)}$. Once the battery rises above V_{SHORT} , the charge current increases to the fastcharge current setting. The SYS voltage is regulated to $V_{SYS(REG)}$ while the battery is linearly charged through the battery FET. Additionally, the thermal regulation loop reduces the charge current to maintain the die temperature at safe levels. Under normal conditions, the time spent in this region is a very short percentage of the total charging time, so if the charge current is reduced, the reduced charge rate does not have a major negative effect on total charge time. If the current limit for the SYS output is reached (limited by the input current limit, or V_{IN_DPM}), the charge current is reduced to provide the system with all the current that is needed. If the charge current is reduced to 0mA, pulling further current from SYS causes the output to fall to the battery voltage and enter supplement mode (see the “*Dynamic Power Path Management*” section for more details).

Once the battery is charged enough to where the system voltage begins to rise above V_{SYSREG} (depends on the charge current setting), the battery FET is turned on fully and the battery is charged with the programmed charge current programmed using the ISET input, I_{CHARGE} . The slew rate for fast charge current is controlled to minimize the current and voltage over-shoot during transient. The charge current is programmed by connecting a resistor from ISET to GND. The value for R_{ISET} is calculated using [Equation 1](#).

$$R_{ISET} = \frac{K_{ISET}}{I_{CHARGE}} \quad (1)$$

Where I_{CHARGE} is the programmed fast charge current and K_{ISET} is the programming factor found in the Electrical Characteristics table.

The charge current is regulated to I_{CHARGE} until the battery is charged to the regulation voltage. Once the battery voltage is close to the regulation voltage, $V_{BAT(REG)}$, the charge current is tapered down as shown in [Figure 2](#) while the SYS output remains connected to the battery. The voltage regulation feedback occurs by monitoring the battery-pack voltage between the BAT and PGND pins.

The bq24278 monitors the charging current during the voltage regulation phase. Once the termination threshold, I_{TERM} , is detected and the battery voltage is above the recharge threshold, the bq24278 terminates charge and turns off the battery charging FET and begins battery detection. The system output is regulated to the $V_{BAT(REG)}$ voltage and supports the full current available from the input and the battery supplement mode (see the “*Dynamic Power Path Management*” section for more details) is still available.

A charge cycle is initiated when one of the following conditions is detected:

1. The battery voltage falls below the $V_{BAT(REG)} - V_{RCH}$ threshold.
2. V_{IN} Power-on reset (POR)
3. \overline{CE} toggle
4. Toggle Hi-Impedance mode (using CD)

If the battery voltage is ever greater than $V_{BAT(REG)}$, the PWM converter is turned off and the battery is discharged to $V_{BAT(REG)}$. This prevents further overcharging the battery and allows the battery to discharge to safe operating levels.

bq24278

SLUSB04 – JUNE 2012

www.ti.com

Battery Detection

When termination conditions are met, a battery detection cycle is started. During battery detection, I_{DETECT} is pulled from V_{BAT} for t_{DETECT} to verify there is a battery. If the battery voltage remains above V_{DETECT} for the full duration of t_{DETECT} , a battery is determined to be present and the IC enters “Charge Done”. If V_{BAT} falls below V_{DETECT} , a “Battery Not Present” fault is signaled and battery detection continues. During the next cycle of battery detection, the bq24278 turns on I_{BATSHORT} for t_{DETECT} . If V_{BAT} rises to V_{DETECT} , the current source is turned off and after t_{DETECT} , the battery detection continues through another current sink cycle. Battery detection continues until charge is disabled or a battery is detected. Once a battery is detected, the fault status clears and a new charge cycle begins. Battery detection is disabled when termination is disabled.

Dynamic Power Path Management

The bq24278 features a SYS output that powers the external system load connected to the battery. This output is active whenever a source is connected to IN or BAT. The following sections discuss the behavior of SYS with a source connected to the supply or a battery source only.

Input Source Connected

When a source is connected to IN, and the bq24278 is enabled, the buck converter starts up. If charging is enabled using $\overline{\text{CE}}$, the charge cycle is initiated. When $V_{\text{BAT}} > 3.5\text{V}$, the SYS output is connected to V_{BAT} . If the SYS voltage falls to $V_{\text{SYS(REG)}}$, it is regulated to that point to maintain the system output even with a deeply discharged or absent battery. In this mode, the SYS output voltage is regulated by the buck converter and the battery FET is linearly regulated to regulate the charge current into the battery. The current from the supply is shared between charging the battery and powering the system load at SYS. The dynamic power path management (DPPM) circuitry of the bq24278 monitors the SYS voltage continuously and if V_{SYS} falls to V_{MINSYS} , adjusts charge current to maintain the load on SYS while preventing the system voltage from crashing. If the charge current is reduced to zero and the load increases further, the bq24278 enters battery supplement mode. During supplement mode, the battery FET is turned on and the battery supplements the system load. When the charge current is reduced by the DPPM regulation loop, the safety timer runs at half speed, so that it is twice as long. This prevents false safety timer faults. See the *Safety Timer* section for more details.

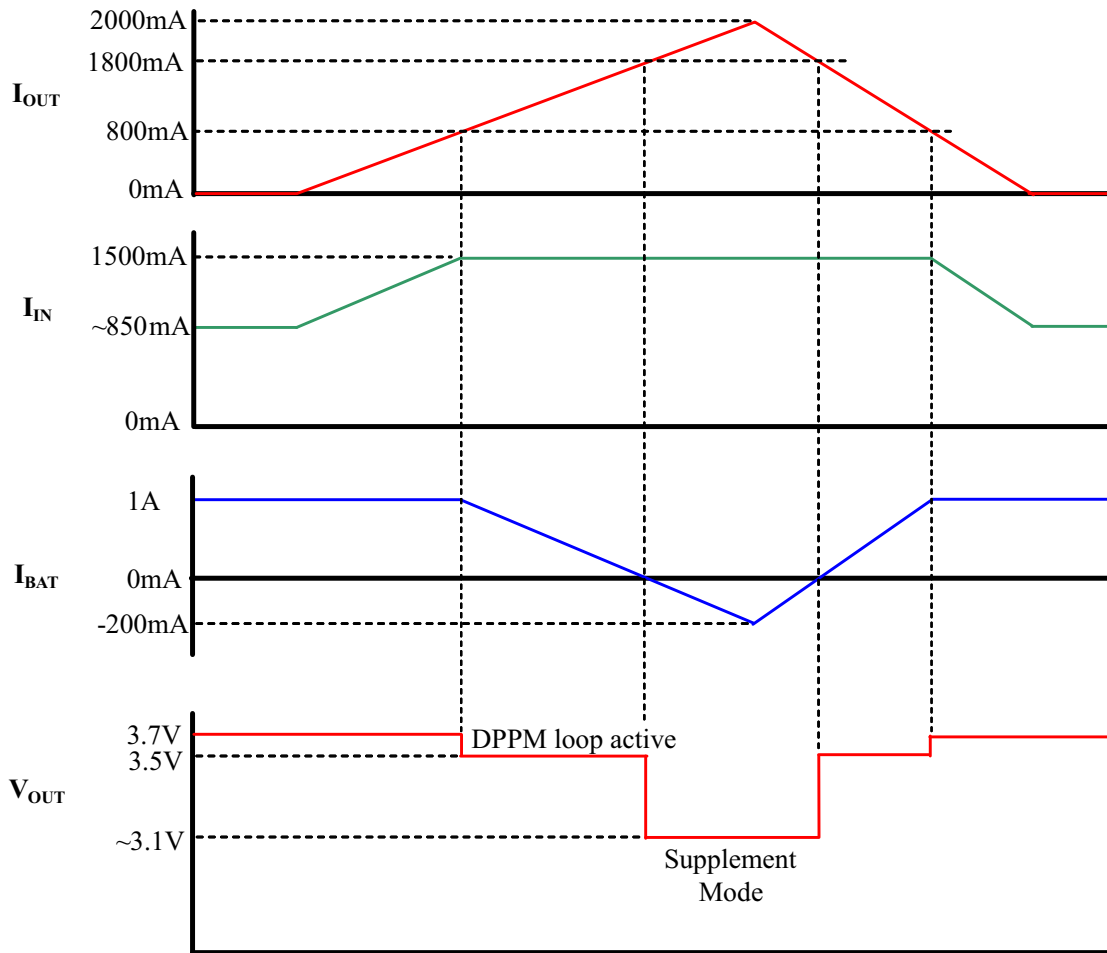

Figure 3. Example DPPM Response ($V_{Supply}=5V$, $V_{BAT} = 3.1V$, 1.5A Input current limit)

If the $V_{BAT(REG)}$ threshold is ever less than the battery voltage, the battery FET is turned off to allow the battery to relax down to $V_{BAT(REG)}$ and the SYS output is regulated to $V_{SYSREG(FETOFF)}$. If the battery is ever above V_{BOVP} , the battery OVP circuit shuts the PWM converter off and the battery FET is turned on to discharge the battery to safe operating levels.

The input current limit for IN is programmable using the ILIM input. Connect a resistor from ILIM to GND to set the maximum input current limit. The programmable range for the IN input current limit is 1000mA to 2.5A. R_{ILIM} is calculated using Equation 2:

$$R_{ILIM} = \frac{K_{ILIM}}{I_{IN_LIM}} \quad (2)$$

Where I_{IN_LIM} is the programmed input current limit and K_{ILIM} is the programming factor found in the Electrical Characteristics table.

Battery Only Connected

When the battery is connected with no input source, the battery FET is turned on similar to supplement mode. In this mode, the current is not regulated; however, there is a short circuit current limit. If the short circuit limit is reached, the battery FET is turned off for the deglitch time. After the deglitch time, the battery FET is turned on to test and see if the short has been removed. If it has not, the FET turns off and the process repeats until the short is removed.

bq24278

SLUSB04 – JUNE 2012

www.ti.com

Battery Discharge FET (BGATE)

The bq24278 contains a MOSFET driver to drive an external P-Channel MOSFET between the battery and the system output. This external FET provides a low impedance path for supply the system from the battery. Connect BGATE to the gate of the external discharge MOSFET. BGATE is on under the following conditions:

1. No valid input supply connected.
2. CD=high (High-Impedance Mode)

This FET is optional and runs in parallel with the internal charge FET during discharge. Note that this FET is not protected by the short circuit current limit.

Safety Timer

At the beginning of charging process, the bq24278 starts the 6 hour safety timer. This timer is active during the entire charging process. If charging has not terminated before the safety timer expires, the charge cycle is terminated and the battery FET is turned off. A new charge cycle must be entered using $\overline{\text{CE}}$ or High Impedance mode or input power must be toggled in order to clear the safety timer fault.

During the fast charge phase, several events increase the timer durations.

1. The system load current reduces the available charging current
2. The input current is reduced because the V_{INDPM} loop is preventing the supply from crashing.
3. The device has entered thermal regulation because the IC junction temperature has exceed $T_{\text{J(REG)}}$

During these events, the timer is slowed by half to extend the timer and prevent any false timer faults. Starting a new charge cycle by toggling the input, toggling the $\overline{\text{CE}}$ pin to disable/enable charge, resets the safety timer. Additionally, thermal shutdown events cause the safety timer to reset.

LDO Output (DRV)

The bq24278 contains a linear regulator (DRV) that is used to supply the internal MOSFET drivers and other circuitry. Additionally, DRV supplies up to 10mA external loads to power the STAT LED or other external circuitry. The LDO is on whenever a supply is connected to the input of the. The DRV is disabled under the following conditions:

1. $V_{\text{IN}} < \text{UVLO}$
2. $V_{\text{IN}} < V_{\text{BAT}} + V_{\text{SLP}}$
3. Thermal Shutdown

External NTC Monitoring (TS)

The I²C interface allows the user to easily implement the JEITA standard for systems where the battery pack thermistor is monitored by the host. Additionally, the bq24278 provides a flexible, voltage-based TS input for monitoring the battery pack NTC thermistor, [Figure 4](#). The voltage at TS is monitored to determine that the battery is at a safe temperature during charging. The bq24278 enables the user to easily implement the JEITA standard for charging temperature. The JEITA specification is shown in [Figure 5](#).

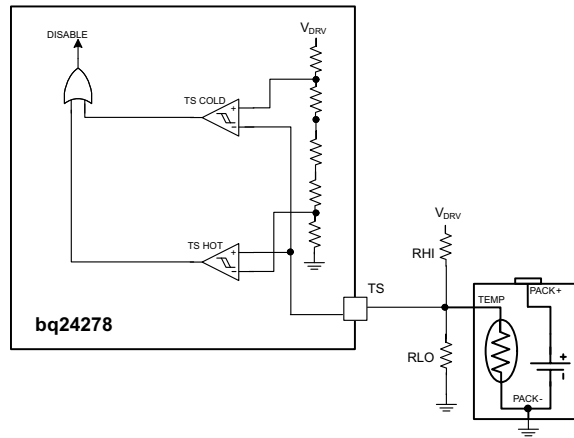

Figure 4. TS Circuit

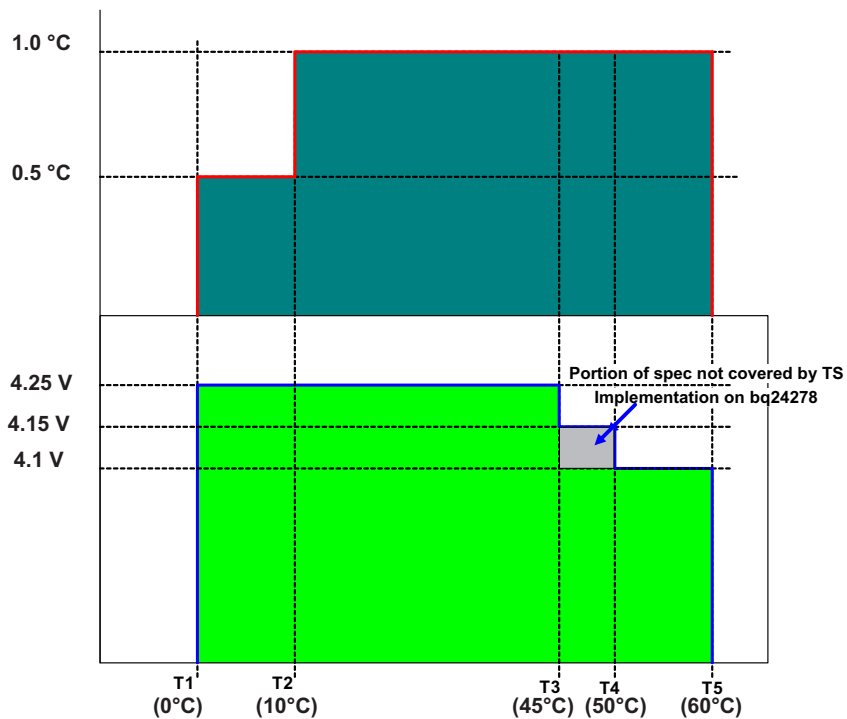

Figure 5. Charge Current During TS Conditions

To satisfy the JEITA requirements, four temperature thresholds are monitored; the cold battery threshold; the cold battery threshold ($T_{NTC} < 0^{\circ}\text{C}$), the cool battery threshold ($0^{\circ}\text{C} < T_{NTC} < 10^{\circ}\text{C}$), the warm battery threshold ($45^{\circ}\text{C} < T_{NTC} < 60^{\circ}\text{C}$) and the hot battery threshold ($T_{NTC} > 60^{\circ}\text{C}$). These temperatures correspond to the V_{COLD} , V_{COOL} , V_{WARM} , and V_{HOT} thresholds. Charging is suspended and timers are suspended when $V_{TS} < V_{HOT}$ or $V_{TS} > V_{COLD}$. When $V_{HOT} < V_{TS} < V_{WARM}$, the battery regulation voltage is reduced by 140 mV from the programmed regulation threshold. When $V_{COOL} < V_{TS} < V_{COLD}$, the charging current is reduced to half of the programmed charge current.

The TS function is voltage based for maximum flexibility. Connect a resistor divider from DRV to GND with TS connected to the center tap to set the threshold. The connections are shown in Figure 10. The resistor values are calculated using the following equations:

bq24278

SLUSB04 – JUNE 2012

www.ti.com

$$RLO = \frac{V_{DRV} \times RCOLD \times RHOT \times \left[\frac{1}{V_{COLD}} - \frac{1}{V_{HOT}} \right]}{RHOT \times \left[\frac{V_{DRV}}{V_{HOT}} - 1 \right] - RCOLD \times \left[\frac{V_{DRV}}{V_{COLD}} - 1 \right]} \quad (3)$$

$$RHI = \frac{\frac{V_{DRV}}{V_{COLD}} - 1}{\frac{1}{RLO} + \frac{1}{RCOLD}} \quad (4)$$

Where:

$$V_{COLD} = 0.60 \times V_{DRV}$$

$$V_{HOT} = 0.30 \times V_{DRV}$$

Where RHOT is the NTC resistance at the hot temperature and RCOLD is the NTC resistance at cold temperature.

The WARM and COOL thresholds are not independently programmable. The COOL and WARM NTC resistances for a selected resistor divider are calculated using the following equations:

$$RCOOL = \frac{RLO \times 0.564 \times RHI}{RLO - RLO \times 0.564 - RHI \times 0.564} \quad (5)$$

$$RWARM = \frac{RLO \times 0.383 \times RHI}{RLO - RLO \times 0.383 - RHI \times 0.383} \quad (6)$$

Thermal Regulation and Protection

During the charging process, to prevent the IC from overheating, bq24278 monitor the junction temperature, T_J , of the die and begins to taper down the charge current once T_J reaches the thermal regulation threshold, T_{CF} . The charge current is reduced to zero when the junction temperature increases about 10°C above TCF. Once the charge current is reduced, the system current is reduced while the battery supplements the load to supply the system. This may cause a thermal shutdown of the bq24278 if the die temperature rises too high. At any state, if T_J exceeds T_{SHTDWN} , bq24278 suspends charging and disables the buck converter. During thermal shutdown mode, PWM is turned off, and the timer is reset. The charging cycle resets when T_J falls below T_{SHTDWN} by approximately 10°C.

Input Voltage Protection in Charge Mode**Sleep Mode**

The bq24278 enters the low-power sleep mode if the voltage on VIN falls below sleep-mode entry threshold, $V_{BAT} + V_{SLP}$, and V_{VBUS} is higher than the undervoltage lockout threshold, V_{UVLO} . This feature prevents draining the battery during the absence of VIN. When $V_{IN} < V_{BAT} + V_{SLP}$, the bq24278 turns off the PWM converter, and turns the battery FET and BGATE on. Once $V_{IN} > V_{BAT} + V_{SLP}$, the device initiates a new charge cycle.

Input Voltage Based DPM

During normal charging process, if the input power source is not able to support the programmed or default charging current, the supply voltage decreases. Once the supply drops to V_{IN_DPM} (set by VDPM), the input current limit is reduced down to prevent the further drop of the supply. This feature ensures IC compatibility with adapters with different current capabilities without a hardware change. Figure 6 shows the V_{IN_DPM} behavior to a current limited source. In this figure the input source has a 750mA current limit and the charging is set to 750mA. The SYS load is then increased to 1.2A.

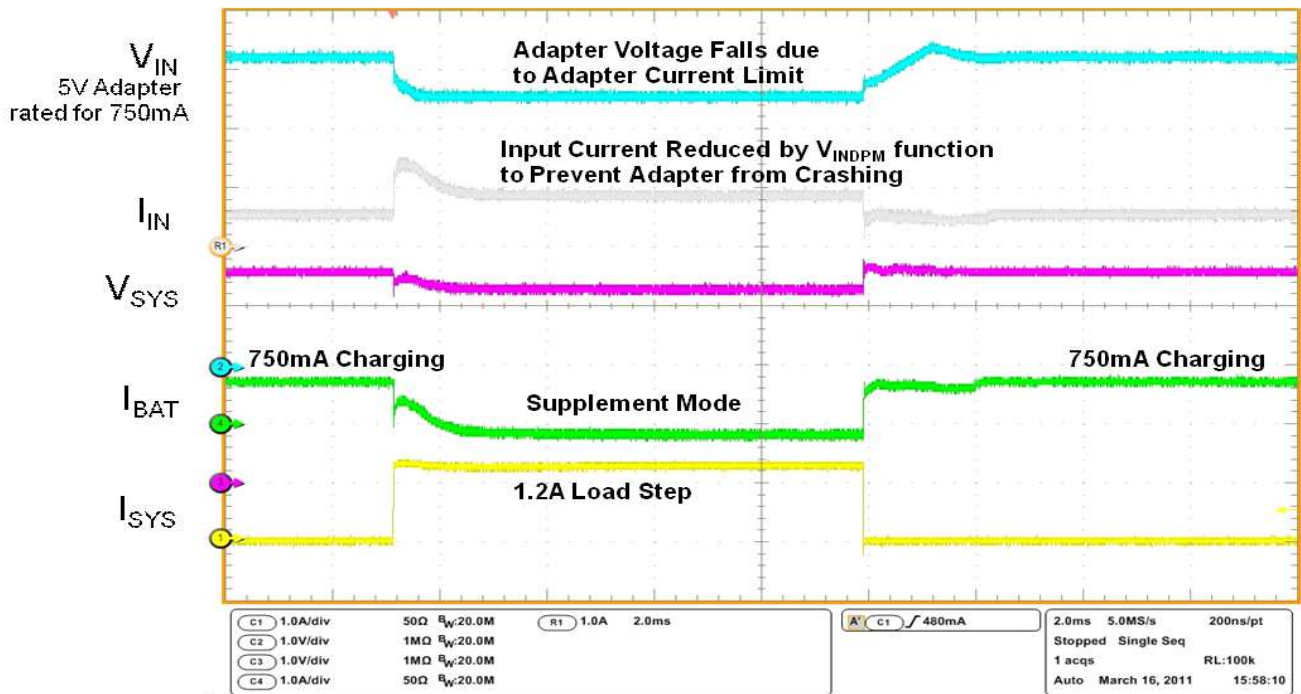

Figure 6. bq24278 V_{IN}-DPM

The V_{INDPM} threshold for the IN input is set using a resistor divider with VDPM connected to the center tap. Select 10kΩ for the bottom resistor. The top resistor is selected using Equation 7:

$$R_{TOP} = \frac{10k\Omega \times (V_{INDPM} - V_{DPM})}{V_{DPM}} \quad (7)$$

Where V_{INDPM} is the desired V_{INDPM} threshold and V_{DPM} is the regulation threshold specified in the Electrical Characteristics table.

Bad Source Detection

When a source is connected to IN, the bq24278 runs a Bad Source Detection procedure to determine if the source is strong enough to provide some current to charge the battery. A current sink is turned on (70mA) for 32ms. If the source is valid after the 32ms ($V_{BAD_SOURCE} < V_{IN} < V_{OVP}$), the buck converter starts up and normal operation continues. If the supply voltage falls below V_{BAD_SOURCE} during the detection, the current sink shuts off for 2s and then retries. The detection circuit retries continuously until a valid source is detected after the detection time. If during normal operation the source falls to V_{BAD_SOURCE}, the bq24278 turns off the PWM converter, turns the battery FET on and runs the bad source detection. Once a good source is detected, the device returns to normal operation.

Input Over-Voltage Protection

The bq24278 provides over-voltage protection on the input that protects downstream circuitry. The built-in input over-voltage protection to protect the device and other components against damage from overvoltage on the input supply (Voltage from V_{IN} to PGND). When V_{IN} > V_{OVP}, the bq24278 turns off the PWM converter, suspends the charging cycle and turns the battery FET on. Once the OVP fault is removed, the device returns to the operation it was in prior to the OVP fault.

Status Indicators (\overline{CHG} , \overline{PG})

The bq24278 contains two open-drain outputs that signal its status. The \overline{PG} output indicates that a valid input source is connected to IN. \overline{PG} is low when $(V_{BAT} + V_{SLP}) < V_{IN} < V_{OVP}$. When there is no supply connected to the input within this range, \overline{PG} is high impedance. Table 1 illustrates the \overline{PG} behavior under different conditions.

The $\overline{\text{CHG}}$ output indicates new charge cycles. When a new charge cycle is initiated by $\overline{\text{CE}}$, toggling High Impedance mode or toggling the input power, $\overline{\text{CHG}}$ goes low and remains low until termination. After termination, $\overline{\text{CHG}}$ remains high impedance until a new charge cycle is initiated. $\overline{\text{CHG}}$ does not go low during recharge cycles. [Table 2](#) illustrates the $\overline{\text{CHG}}$ behavior under different conditions.

Connect $\overline{\text{PG}}$ and $\overline{\text{CHG}}$ to the DRV output through an LED for visual indication, or connect through a 100k Ω pullup to the required logic rail for host indication.

Table 1. $\overline{\text{PG}}$ Status Indicator

CHARGE STATE	$\overline{\text{PG}}$ BEHAVIOR
$V_{\text{IN}} < V_{\text{UVLO}}$	High-Impedance
$V_{\text{IN}} < (V_{\text{BAT}} + V_{\text{SLP}})$	High-Impedance
$(V_{\text{BAT}} + V_{\text{SLP}}) < V_{\text{IN}} < V_{\text{OVP}}$	Low
$V_{\text{IN}} > V_{\text{OVP}}$	High-Impedance

Table 2. $\overline{\text{CHG}}$ Status Indicator

CHARGE STATE	$\overline{\text{CHG}}$ BEHAVIOR
Charge in progress	Low (first charge cycle)
Charging suspended by thermal loop	High-Impedance (recharge cycles)
Charge Done	High-Impedance
Recharge Cycle after Termination	
Timer Fault	
No Valid Supply, $V_{\text{IN}} > V_{\text{OVP}}$ or $V_{\text{IN}} < V_{\text{SLEEP}}$	
No Battery Present	

APPLICATION INFORMATION

Output Inductor and Capacitor Selection Guidelines

When selecting an inductor, several attributes must be examined to find the right part for the application. First, the inductance value should be selected. The bq24278 is designed to work with 1.5µH to 2.2µH inductors. The chosen value will have an effect on efficiency and package size. Due to the smaller current ripple, some efficiency gain is reached using the 2.2µH inductor, however, due to the physical size of the inductor, this may not be a viable option. The 1.5µH inductor provides a good tradeoff between size and efficiency.

Once the inductance has been selected, the peak current must be calculated in order to choose the current rating of the inductor. Use [Equation 8](#) to calculate the peak current.

$$I_{PEAK} = I_{LOAD(MAX)} \times \left(1 + \frac{\%RIPPLE}{2} \right) \quad (8)$$

The inductor selected must have a saturation current rating less than or equal to the calculated I_{PEAK} . Due to the high currents possible with the bq24278, a thermal analysis must also be done for the inductor. Many inductors have 40°C temperature rise rating. This is the DC current that will cause a 40°C temperature rise above the ambient temperature in the inductor. For this analysis, the typical load current may be used adjusted for the duty cycle of the load transients. For example, if the application requires a 1.5A DC load with peaks at 2.5A 20% of the time, a Δ40°C temperature rise current must be greater than 1.7A:

$$I_{TEMPRISE} = I_{LOAD} + D \times (I_{PEAK} - I_{LOAD}) = 1.5 \text{ A} + 0.2 \times (2.5 \text{ A} - 1.5 \text{ A}) = 1.7 \text{ A} \quad (9)$$

The bq24278 provides internal loop compensation. Using this scheme, the bq24278 is stable with 10µF to 200µF of local capacitance. The capacitance on the SYS rail can be higher if distributed amongst the rail. To reduce the output voltage ripple, a ceramic capacitor with the capacitance between 10µF and 47µF is recommended for local bypass to SYS.

PCB Layout Guidelines

It is important to pay special attention to the PCB layout. Figure 7 provides a sample layout for the high current paths of the bq24278.

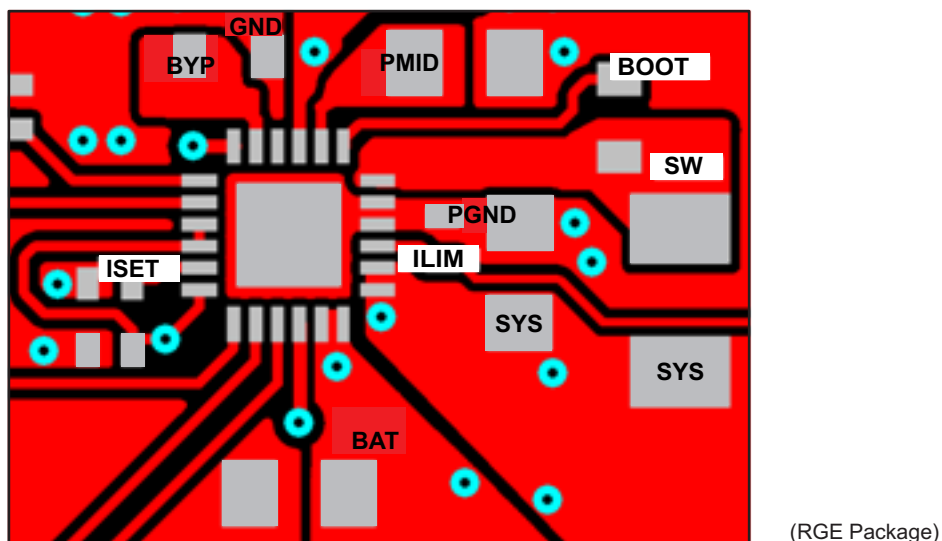

Figure 7. Recommended bq24278 PCB Layout for RGE Device

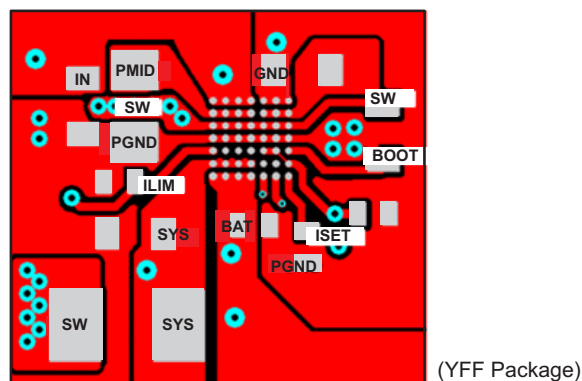

Figure 8. Recommended bq24278 PCB Layout for YFF Device

The following provides some guidelines:

- To obtain optimal performance, the power input capacitors, connected from the PMID input to PGND, must be placed as close as possible to the bq24278
- Place 4.7 μ F input capacitor as close to PMID pin and PGND pin as possible to make high frequency current loop area as small as possible. Place 1 μ F input capacitor GNDs as close to the respective PMID cap GND and PGND pins as possible to minimize the ground difference between the input and PMID.
- The local bypass capacitor from SYS to GND should be connected between the SYS pin and PGND of the IC. The intent is to minimize the current path loop area from the SW pin through the LC filter and back to the PGND pin.
- Place ISET resistor very close to the ISET pin.
- Place ILIM resistor very close to the ILIIM pin.
- Place all decoupling capacitor close to their respective IC pin and as close as to PGND (do not place components such that routing interrupts power stage currents). All small control signals should be routed away from the high current paths.
- The PCB should have a ground plane (return) connected directly to the return of all components through vias (two vias per capacitor for power-stage capacitors, one via per capacitor for small-signal components). It is

also recommended to put vias inside the PGND pads for the IC, if possible. A star ground design approach is typically used to keep circuit block currents isolated (high-power/low-power small-signal) which reduces noise-coupling and ground-bounce issues. A single ground plane for this design gives good results. With this small layout and a single ground plane, there is no ground-bounce issue, and having the components segregated minimizes coupling between signals.

- The high-current charge paths into IN, BAT, SYS and from the SW pins must be sized appropriately for the maximum charge current in order to avoid voltage drops in these traces. The PGND pins should be connected to the ground plane to return current through the internal low-side FET.
- For high-current applications, the balls for the power paths should be connected to as much copper in the board as possible. This allows better thermal performance as the board pulls heat away from the IC.

PACKAGE SUMMARY

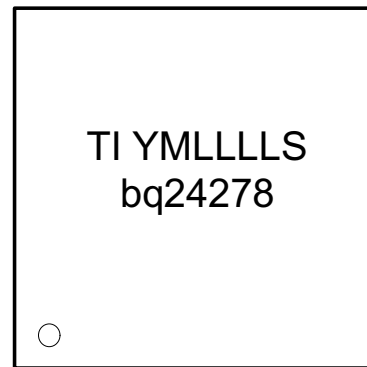
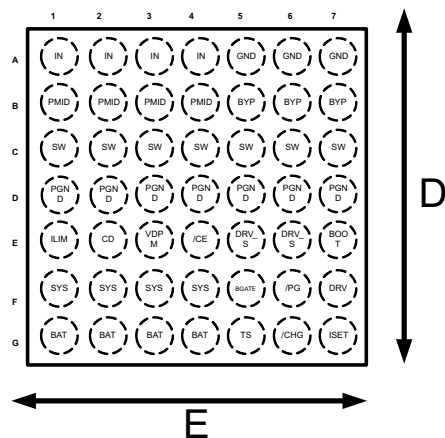

0-Pin A1 Marker, TI-TI Letters, YM- Year Month Date Code , LLLL-Lot Trace Code , S-Assembly Site Code

CHIP SCALE PACKAGING DIMENSIONS

The bq2427x devices are available in a 49-bump chip scale package (YFF, NanoFree™). The package dimensions are :

- D – 2.78mm ± 0.05mm
- E – 2.78mm ± 0.05mm

PACKAGING INFORMATION

Orderable Device	Status (1)	Package Type	Package Drawing	Pins	Package Qty	Eco Plan (2)	Lead/Ball Finish (6)	MSL Peak Temp (3)	Op Temp (°C)	Device Marking (4/5)	Samples
BQ24278RGER	NRND	VQFN	RGE	24	3000	Green (RoHS & no Sb/Br)	CU NIPDAU	Level-2-260C-1 YEAR	-40 to 85	BQ 24278	
BQ24278RGET	NRND	VQFN	RGE	24	250	Green (RoHS & no Sb/Br)	CU NIPDAU	Level-2-260C-1 YEAR	-40 to 85	BQ 24278	
BQ24278YFFR	NRND	DSBGA	YFF	49	3000	Green (RoHS & no Sb/Br)	SNAGCU	Level-1-260C-UNLIM	-40 to 85	BQ24278	
BQ24278YFFT	NRND	DSBGA	YFF	49	250	Green (RoHS & no Sb/Br)	SNAGCU	Level-1-260C-UNLIM	-40 to 85	BQ24278	

(1) The marketing status values are defined as follows:

ACTIVE: Product device recommended for new designs.

LIFEBUY: TI has announced that the device will be discontinued, and a lifetime-buy period is in effect.

NRND: Not recommended for new designs. Device is in production to support existing customers, but TI does not recommend using this part in a new design.

PREVIEW: Device has been announced but is not in production. Samples may or may not be available.

OBSELETE: TI has discontinued the production of the device.

(2) Eco Plan - The planned eco-friendly classification: Pb-Free (RoHS), Pb-Free (RoHS Exempt), or Green (RoHS & no Sb/Br) - please check <http://www.ti.com/productcontent> for the latest availability information and additional product content details.

TBD: The Pb-Free/Green conversion plan has not been defined.

Pb-Free (RoHS): TI's terms "Lead-Free" or "Pb-Free" mean semiconductor products that are compatible with the current RoHS requirements for all 6 substances, including the requirement that lead not exceed 0.1% by weight in homogeneous materials. Where designed to be soldered at high temperatures, TI Pb-Free products are suitable for use in specified lead-free processes.

Pb-Free (RoHS Exempt): This component has a RoHS exemption for either 1) lead-based flip-chip solder bumps used between the die and package, or 2) lead-based die adhesive used between the die and leadframe. The component is otherwise considered Pb-Free (RoHS compatible) as defined above.

Green (RoHS & no Sb/Br): TI defines "Green" to mean Pb-Free (RoHS compatible), and free of Bromine (Br) and Antimony (Sb) based flame retardants (Br or Sb do not exceed 0.1% by weight in homogeneous material)

(3) MSL, Peak Temp. - The Moisture Sensitivity Level rating according to the JEDEC industry standard classifications, and peak solder temperature.

(4) There may be additional marking, which relates to the logo, the lot trace code information, or the environmental category on the device.

(5) Multiple Device Markings will be inside parentheses. Only one Device Marking contained in parentheses and separated by a "~" will appear on a device. If a line is indented then it is a continuation of the previous line and the two combined represent the entire Device Marking for that device.

(6) Lead/Ball Finish - Orderable Devices may have multiple material finish options. Finish options are separated by a vertical ruled line. Lead/Ball Finish values may wrap to two lines if the finish value exceeds the maximum column width.

Important Information and Disclaimer: The information provided on this page represents TI's knowledge and belief as of the date that it is provided. TI bases its knowledge and belief on information provided by third parties, and makes no representation or warranty as to the accuracy of such information. Efforts are underway to better integrate information from third parties. TI has taken and continues to take reasonable steps to provide representative and accurate information but may not have conducted destructive testing or chemical analysis on incoming materials and chemicals. TI and TI suppliers consider certain information to be proprietary, and thus CAS numbers and other limited information may not be available for release.

In no event shall TI's liability arising out of such information exceed the total purchase price of the TI part(s) at issue in this document sold by TI to Customer on an annual basis.

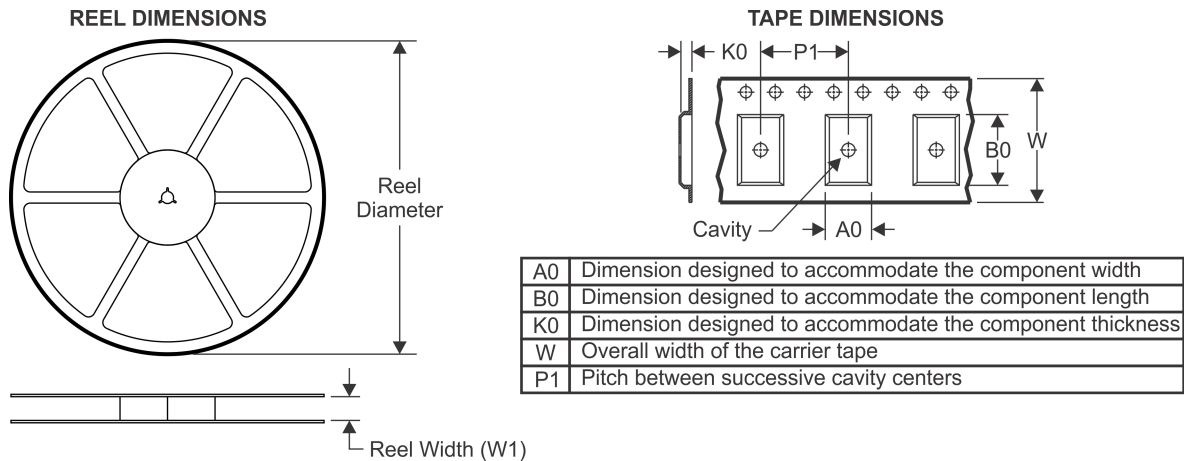
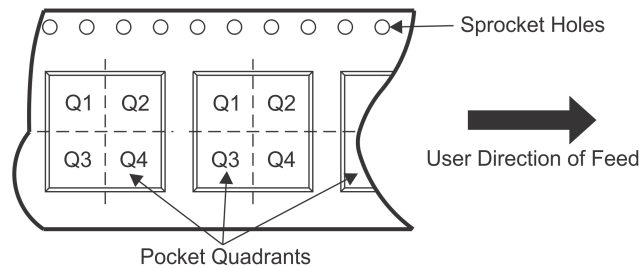
TAPE AND REEL INFORMATION

QUADRANT ASSIGNMENTS FOR PIN 1 ORIENTATION IN TAPE

*All dimensions are nominal

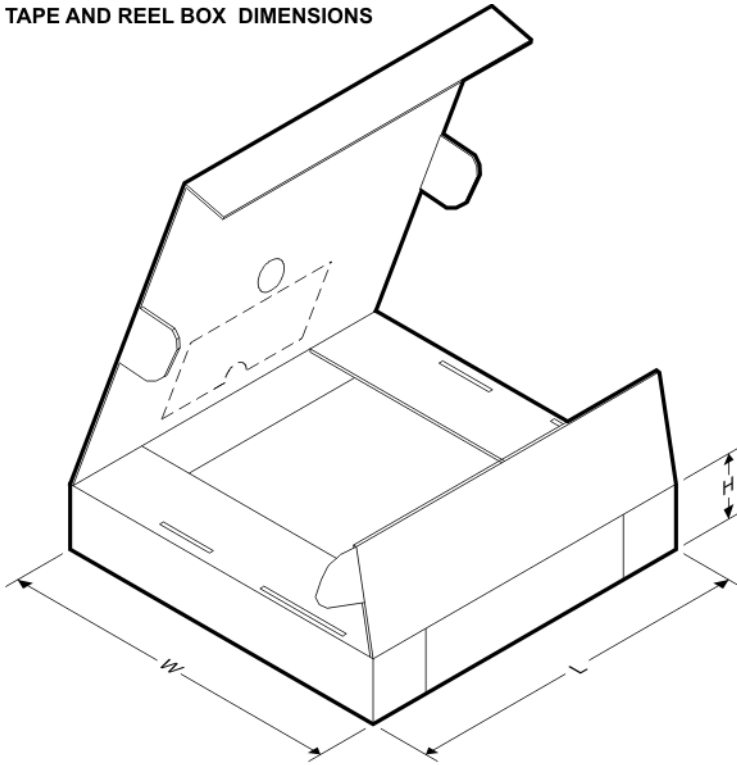
Device	Package Type	Package Drawing	Pins	SPQ	Reel Diameter (mm)	Reel Width W1 (mm)	A0 (mm)	B0 (mm)	K0 (mm)	P1 (mm)	W (mm)	Pin1 Quadrant
BQ24278RGER	VQFN	RGE	24	3000	330.0	12.4	4.25	4.25	1.15	8.0	12.0	Q2
BQ24278RGET	VQFN	RGE	24	250	180.0	12.4	4.25	4.25	1.15	8.0	12.0	Q2
BQ24278YFFR	DSBGA	YFF	49	3000	180.0	8.4	2.93	2.93	0.81	4.0	8.0	Q1
BQ24278YFFT	DSBGA	YFF	49	250	180.0	8.4	2.93	2.93	0.81	4.0	8.0	Q1

TAPE AND REEL BOX DIMENSIONS

*All dimensions are nominal

Device	Package Type	Package Drawing	Pins	SPQ	Length (mm)	Width (mm)	Height (mm)
BQ24278RGER	VQFN	RGE	24	3000	367.0	367.0	35.0
BQ24278RGET	VQFN	RGE	24	250	210.0	185.0	35.0
BQ24278YFFR	DSBGA	YFF	49	3000	182.0	182.0	20.0
BQ24278YFFT	DSBGA	YFF	49	250	182.0	182.0	20.0

RGE 24

GENERIC PACKAGE VIEW

VQFN - 1 mm max height

PLASTIC QUAD FLATPACK - NO LEAD

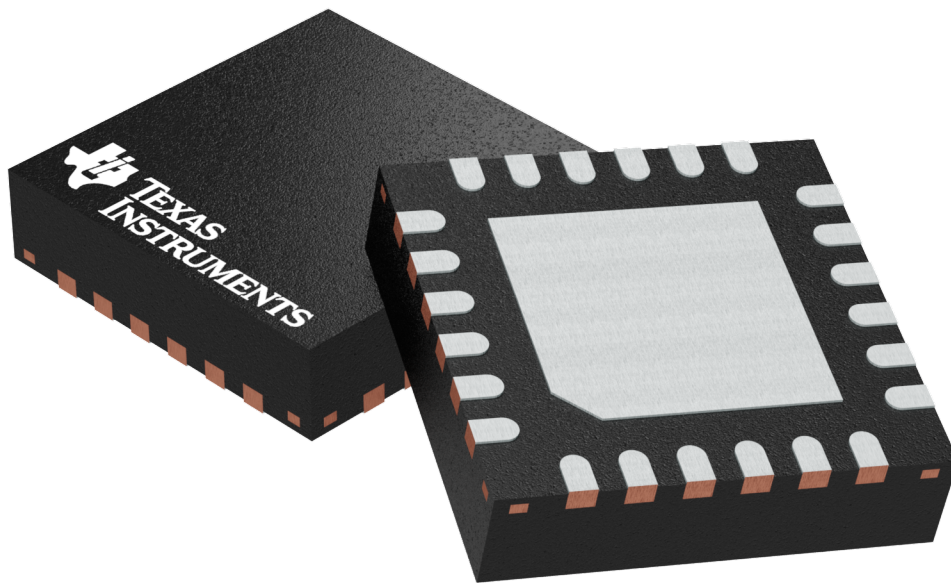

Images above are just a representation of the package family, actual package may vary.
Refer to the product data sheet for package details.

4204104/H

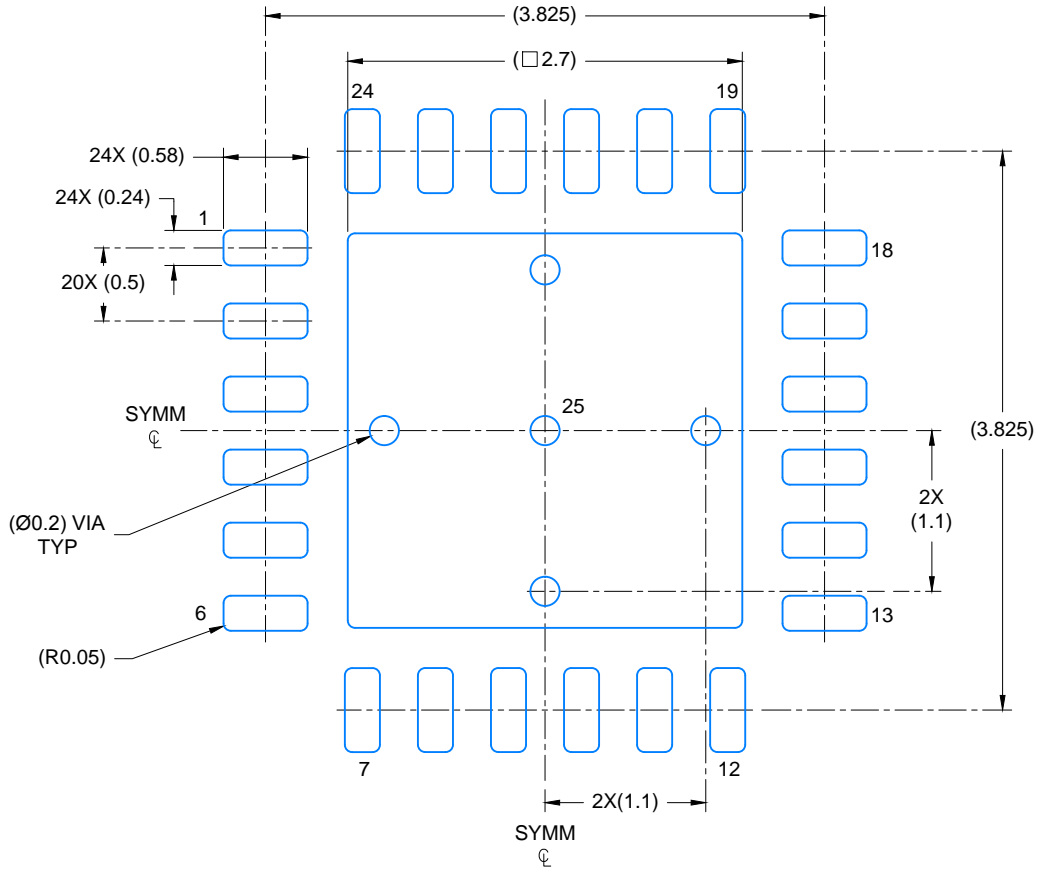

LAND PATTERN EXAMPLE
SCALE: 20X

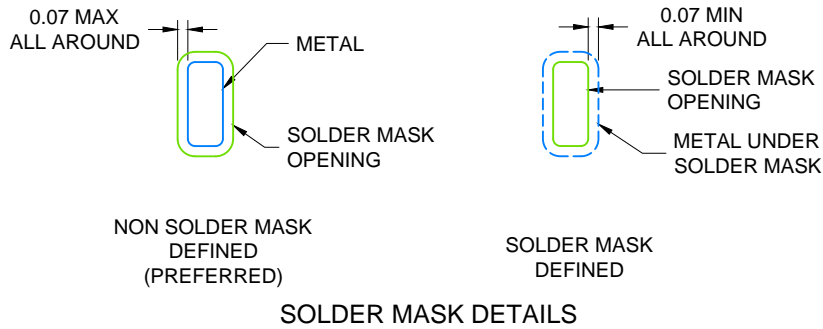

4219016 / A 08/2017

NOTES: (continued)

4. This package is designed to be soldered to a thermal pad on the board. For more information, see Texas Instruments literature number SLUA271 (www.ti.com/lit/slua271).
5. Solder mask tolerances between and around signal pads can vary based on board fabrication site.

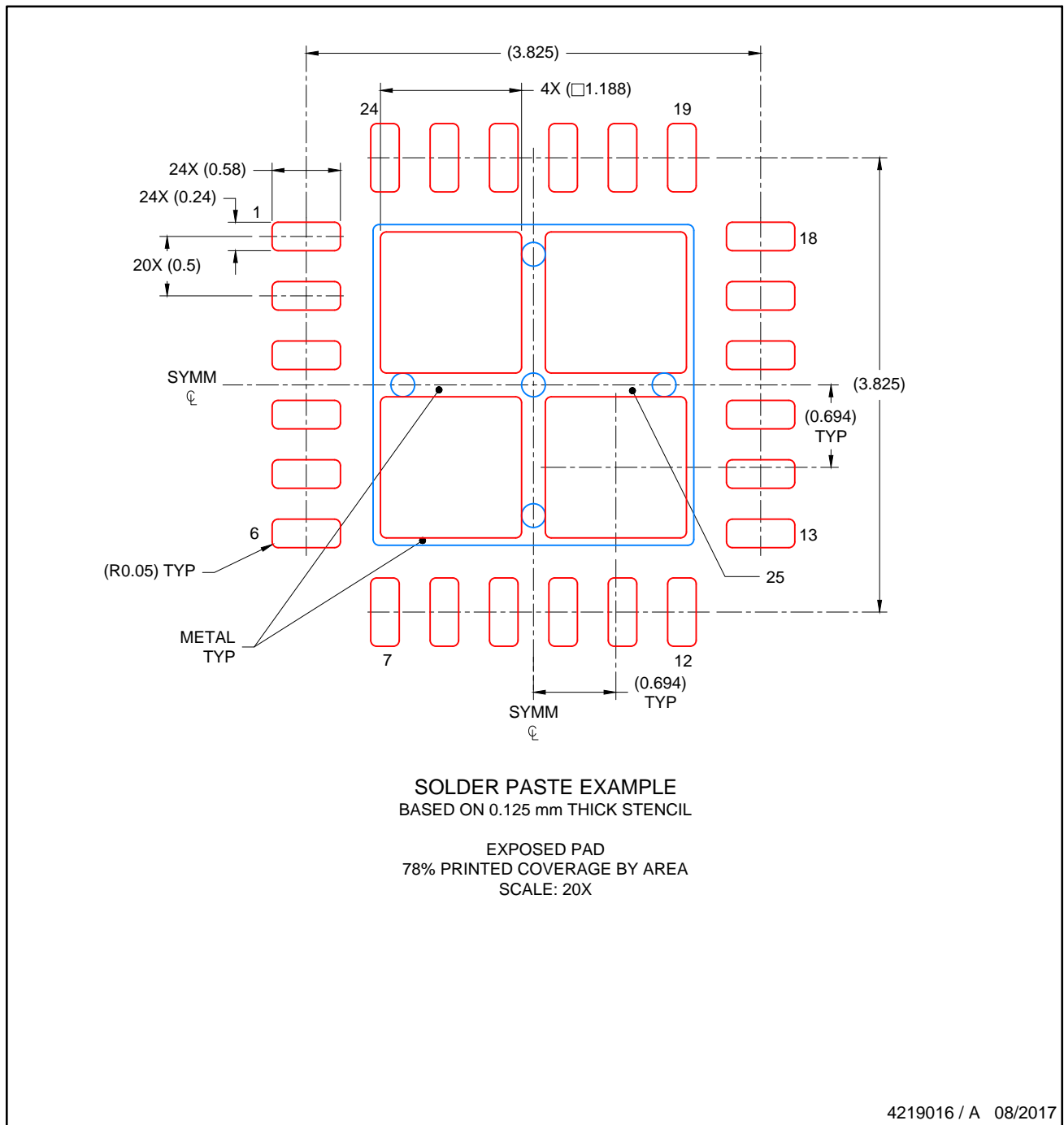

NOTES: (continued)

6. Laser cutting apertures with trapezoidal walls and rounded corners may offer better paste release. IPC-7525 may have alternate design recommendations..

YFF (R-XBGA-N49)

DIE-SIZE BALL GRID ARRAY

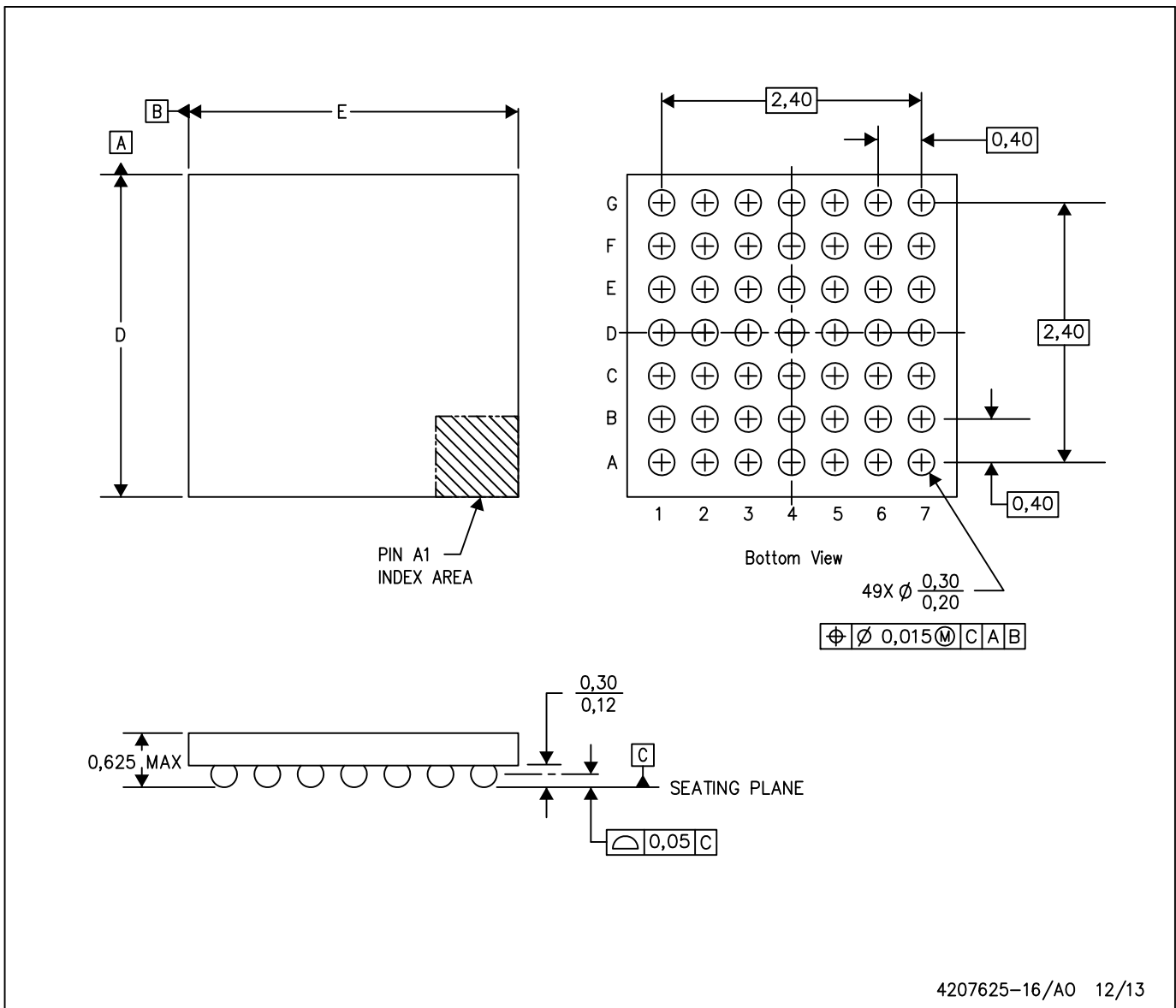

- NOTES: A. All linear dimensions are in millimeters. Dimensioning and tolerancing per ASME Y14.5M-1994.
 B. This drawing is subject to change without notice.
 C. NanoFree™ package configuration.

NanoFree is a trademark of Texas Instruments.

IMPORTANT NOTICE

Texas Instruments Incorporated (TI) reserves the right to make corrections, enhancements, improvements and other changes to its semiconductor products and services per JESD46, latest issue, and to discontinue any product or service per JESD48, latest issue. Buyers should obtain the latest relevant information before placing orders and should verify that such information is current and complete.

TI's published terms of sale for semiconductor products (<http://www.ti.com/sc/docs/stdterms.htm>) apply to the sale of packaged integrated circuit products that TI has qualified and released to market. Additional terms may apply to the use or sale of other types of TI products and services.

Reproduction of significant portions of TI information in TI data sheets is permissible only if reproduction is without alteration and is accompanied by all associated warranties, conditions, limitations, and notices. TI is not responsible or liable for such reproduced documentation. Information of third parties may be subject to additional restrictions. Resale of TI products or services with statements different from or beyond the parameters stated by TI for that product or service voids all express and any implied warranties for the associated TI product or service and is an unfair and deceptive business practice. TI is not responsible or liable for any such statements.

Buyers and others who are developing systems that incorporate TI products (collectively, "Designers") understand and agree that Designers remain responsible for using their independent analysis, evaluation and judgment in designing their applications and that Designers have full and exclusive responsibility to assure the safety of Designers' applications and compliance of their applications (and of all TI products used in or for Designers' applications) with all applicable regulations, laws and other applicable requirements. Designer represents that, with respect to their applications, Designer has all the necessary expertise to create and implement safeguards that (1) anticipate dangerous consequences of failures, (2) monitor failures and their consequences, and (3) lessen the likelihood of failures that might cause harm and take appropriate actions. Designer agrees that prior to using or distributing any applications that include TI products, Designer will thoroughly test such applications and the functionality of such TI products as used in such applications.

TI's provision of technical, application or other design advice, quality characterization, reliability data or other services or information, including, but not limited to, reference designs and materials relating to evaluation modules, (collectively, "TI Resources") are intended to assist designers who are developing applications that incorporate TI products; by downloading, accessing or using TI Resources in any way, Designer (individually or, if Designer is acting on behalf of a company, Designer's company) agrees to use any particular TI Resource solely for this purpose and subject to the terms of this Notice.

TI's provision of TI Resources does not expand or otherwise alter TI's applicable published warranties or warranty disclaimers for TI products, and no additional obligations or liabilities arise from TI providing such TI Resources. TI reserves the right to make corrections, enhancements, improvements and other changes to its TI Resources. TI has not conducted any testing other than that specifically described in the published documentation for a particular TI Resource.

Designer is authorized to use, copy and modify any individual TI Resource only in connection with the development of applications that include the TI product(s) identified in such TI Resource. NO OTHER LICENSE, EXPRESS OR IMPLIED, BY ESTOPPEL OR OTHERWISE TO ANY OTHER TI INTELLECTUAL PROPERTY RIGHT, AND NO LICENSE TO ANY TECHNOLOGY OR INTELLECTUAL PROPERTY RIGHT OF TI OR ANY THIRD PARTY IS GRANTED HEREIN, including but not limited to any patent right, copyright, mask work right, or other intellectual property right relating to any combination, machine, or process in which TI products or services are used. Information regarding or referencing third-party products or services does not constitute a license to use such products or services, or a warranty or endorsement thereof. Use of TI Resources may require a license from a third party under the patents or other intellectual property of the third party, or a license from TI under the patents or other intellectual property of TI.

TI RESOURCES ARE PROVIDED "AS IS" AND WITH ALL FAULTS. TI DISCLAIMS ALL OTHER WARRANTIES OR REPRESENTATIONS, EXPRESS OR IMPLIED, REGARDING RESOURCES OR USE THEREOF, INCLUDING BUT NOT LIMITED TO ACCURACY OR COMPLETENESS, TITLE, ANY EPIDEMIC FAILURE WARRANTY AND ANY IMPLIED WARRANTIES OF MERCHANTABILITY, FITNESS FOR A PARTICULAR PURPOSE, AND NON-INFRINGEMENT OF ANY THIRD PARTY INTELLECTUAL PROPERTY RIGHTS. TI SHALL NOT BE LIABLE FOR AND SHALL NOT DEFEND OR INDEMNIFY DESIGNER AGAINST ANY CLAIM, INCLUDING BUT NOT LIMITED TO ANY INFRINGEMENT CLAIM THAT RELATES TO OR IS BASED ON ANY COMBINATION OF PRODUCTS EVEN IF DESCRIBED IN TI RESOURCES OR OTHERWISE. IN NO EVENT SHALL TI BE LIABLE FOR ANY ACTUAL, DIRECT, SPECIAL, COLLATERAL, INDIRECT, PUNITIVE, INCIDENTAL, CONSEQUENTIAL OR EXEMPLARY DAMAGES IN CONNECTION WITH OR ARISING OUT OF TI RESOURCES OR USE THEREOF, AND REGARDLESS OF WHETHER TI HAS BEEN ADVISED OF THE POSSIBILITY OF SUCH DAMAGES.

Unless TI has explicitly designated an individual product as meeting the requirements of a particular industry standard (e.g., ISO/TS 16949 and ISO 26262), TI is not responsible for any failure to meet such industry standard requirements.

Where TI specifically promotes products as facilitating functional safety or as compliant with industry functional safety standards, such products are intended to help enable customers to design and create their own applications that meet applicable functional safety standards and requirements. Using products in an application does not by itself establish any safety features in the application. Designers must ensure compliance with safety-related requirements and standards applicable to their applications. Designer may not use any TI products in life-critical medical equipment unless authorized officers of the parties have executed a special contract specifically governing such use. Life-critical medical equipment is medical equipment where failure of such equipment would cause serious bodily injury or death (e.g., life support, pacemakers, defibrillators, heart pumps, neurostimulators, and implantables). Such equipment includes, without limitation, all medical devices identified by the U.S. Food and Drug Administration as Class III devices and equivalent classifications outside the U.S.

TI may expressly designate certain products as completing a particular qualification (e.g., Q100, Military Grade, or Enhanced Product). Designers agree that it has the necessary expertise to select the product with the appropriate qualification designation for their applications and that proper product selection is at Designers' own risk. Designers are solely responsible for compliance with all legal and regulatory requirements in connection with such selection.

Designer will fully indemnify TI and its representatives against any damages, costs, losses, and/or liabilities arising out of Designer's non-compliance with the terms and provisions of this Notice.

Looking for pricing, stock, or lifecycle information?

Click below to explore more details on WIN SOURCE:

 [View BQ24278RGER](#) on WIN SOURCE

 [Texas Instruments](#) Information

Optimize Your Supply Chain with WIN SOURCE Solutions

-  Global Sourcing Solution
-  Obsolete Management
-  Cost Control Management
-  Shortage Management
-  Alternative Solution
-  Excess Inventory Management