



# THE DATASHEET OF BQ24160ARGER



# bq2416xx 2.5A, Dual-Input, Single-Cell Switched-Mode Li-Ion Battery Charger with Power Path Management and I<sup>2</sup>C Interface

## 1 Features

- High-Efficiency Switched-Mode Charger with Separate Power Path Control
  - Instantly Start Up System from a Deeply Discharged Battery or No Battery
- Compatible with MaxLife™ Technology for Faster Charging When Used in Conjunction With bq27530
- Dual Input, Integrated FET Charger for up to 2.5-A Charging
  - 20-V input rating, with Overvoltage Protection (OVP)
    - 6.5 V for USB Input up to 1.5 A
    - 10.5 V for IN input (bq24160, bq24160A, bq24161, bq24163) up to 2.5 A
    - 6.5 V for IN input (bq24168) up to 2.5 A
- Safe and Accurate Battery-Management Functions
  - 1% Battery Regulation Accuracy
  - 10% Charge Current Accuracy
- Charge Parameters Programmed Using I<sup>2</sup>C Interface
- Voltage-Based, NTC Monitoring Input
  - JEITA Compatible (bq24160, bq24160A, bq24161B, bq24163, bq24168)
- Available in small 2.8-mm × 2.8-mm 49-ball WCSP or 4-mm × 4-mm VQFN-24 Packages

## 2 Applications

- Handheld Products
- Portable Media Players
- Portable Equipment
- Netbook and Portable Internet Devices

## 3 Description

The bq24160, bq24160A, bq24161, bq24161B, bq24163, and bq24168 are highly integrated single-cell Li-Ion battery charger and system power path management devices targeted for space-limited, portable applications with high-capacity batteries. The single-cell charger has dual inputs which allow operation from either a USB port or a higher-power input supply (that is, AC adapter or wireless charging input) for a versatile solution. The two inputs are fully isolated from each other and are easily selectable using the I<sup>2</sup>C interface.

The power path management feature allows the bq2416xx to power the system from a high-efficiency DC-DC converter while simultaneously and independently charging the battery. The power-path management architecture enables the system to run with a defective or absent battery pack and enables instant system turnon even with a totally discharged battery or no battery.

### Device Information

PART NUMBER	PACKAGE	BODY SIZE (NOM)
bq2416xx	VQFN (24)	4.00 mm × 4.00 mm
	DSBGA (49)	2.80 mm × 2.80 mm

(1) For all available packages, see the orderable addendum at the end of the datasheet.

## 4 Application Schematic

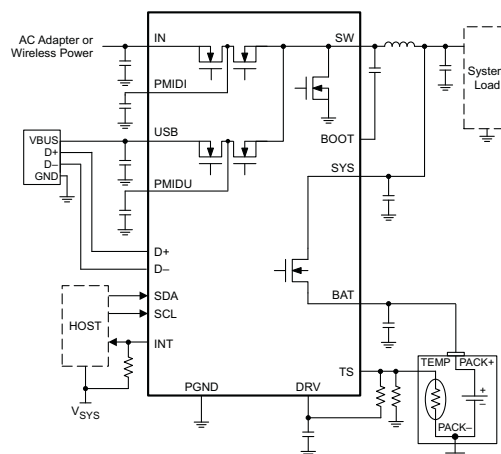

## Table of Contents

<b>1 Features</b> .....	1	9.5 Programming.....	26
<b>2 Applications</b> .....	1	9.6 Register Maps .....	29
<b>3 Description</b> .....	1	<b>10 Application and Implementation</b> .....	34
<b>4 Application Schematic</b> .....	1	10.1 Application Information.....	34
<b>5 Revision History</b> .....	2	10.2 Typical Application .....	34
<b>6 Device Comparison Table</b> .....	4	<b>11 Power Supply Recommendations</b> .....	38
<b>7 Pin Configuration and Functions</b> .....	4	11.1 Requirements for SYS Output .....	38
<b>8 Specifications</b> .....	6	11.2 Requirements for Charging.....	38
8.1 Absolute Maximum Ratings .....	6	<b>12 Layout</b> .....	39
8.2 Handling Ratings.....	6	12.1 Layout Guidelines .....	39
8.3 Recommended Operating Conditions.....	6	12.2 Layout Example .....	40
8.4 Thermal Information .....	7	<b>13 Device and Documentation Support</b> .....	41
8.5 Electrical Characteristics.....	7	13.1 Related Links .....	41
8.6 Typical Characteristics.....	10	13.2 Community Resources.....	41
<b>9 Detailed Description</b> .....	12	13.3 Trademarks .....	41
9.1 Overview .....	12	13.4 Electrostatic Discharge Caution.....	41
9.2 Functional Block Diagram .....	13	13.5 Glossary .....	41
9.3 Feature Description.....	14	<b>14 Mechanical, Packaging, and Orderable Information</b> .....	41
9.4 Device Functional Modes.....	26		

## 5 Revision History

NOTE: Page numbers for previous revisions may differ from page numbers in the current version.

Changes from Revision F (July 2014) to Revision G	Page
• Deleted hyperlink to unpublished application note SLUA727.....	26

Changes from Revision E (November 2013) to Revision F	Page
• Added <i>Handling Rating</i> table, <i>Feature Description</i> section, <i>Device Functional Modes</i> , <i>Application and Implementation</i> section, <i>Power Supply Recommendations</i> section, <i>Layout</i> section, <i>Device and Documentation Support</i> section, and <i>Mechanical, Packaging, and Orderable Information</i> section.....	1
• Changed the Ordering Information table to the Device Comparison Table .....	4
• Changed to $V_{BAD\_SOURCE}$ include values for "During Bad Source Detection" .....	8
• Changed the Functional Block Diagram. Changed the device numbers above D+/D- and PSEL.....	13
• Changed the PWM Controller in Charge Mode section to include the soft-start function.....	15
• Changed the Battery Charging Process section. New text added starting with "The bq2416xx monitors the charging current.." .....	15
• Changed the Input Source Connected section.....	16
• Changed the Input Source Connected section.....	18
• Added the Reverse Boost (Boost Back) Prevention Circuit section .....	24

Changes from Revision D (November 2012) to Revision E	Page
• Added Feature: Compatible with MaxLife Technology for Faster Charging When Used in Conjunction With bq27530 .....	1
• Changed From: QFN-24 Package To: VQFN-24 Package throughout the data sheet.....	1

---

**Changes from Revision C (October 2012) to Revision D** **Page**

- Changed the Ordering Information table to include the WSCP package for bq24161BRGR and bq24161BYFF ..... 4
- 

**Changes from Revision B (September 2012) to Revision C** **Page**

- Changed the Ordering Information table to include bq24160A ..... 4
- 

**Changes from Revision A (March 2012) to Revision B** **Page**

- Changed the Ordering Information table to include bq24161B ..... 4
  - Changed text From: "battery FET (Q6)" To: "battery FET (Q4)" in the Battery Only Connected section ..... 18
  - Changed From:  $V_{WARM} < V_{TS} < V_{HOT}$  To:  $V_{WARM} > V_{TS} > V_{HOT}$ , and Changed From:  $V_{COLD} < V_{TS} < V_{COOL}$  To:  $V_{COLD} > V_{TS} > V_{COOL}$  in the External NTC Monitoring (TS) section ..... 21
  - Changed [Figure 33](#) ..... 40
- 

**Changes from Original (November 2011) to Revision A** **Page**

- Changed the USB Pin numbers in the YFF package for bq24160/3 From: A5-A6 To: A5-A7 ..... 5
  - Changed  $V_{BATREG}$  - Voltage regulation accuracy ..... 7
  - Changed [Figure 21](#) ..... 34
  - Changed [Figure 22](#) ..... 35
-

## 6 Device Comparison Table

PART NUMBER <sup>(1)</sup> <sup>(2)</sup>	USB OVP	IN OVP	USB DETECTION	TIMERS (Safety and Watchdog)	NTC MONITORING	V <sub>BATSHRT/</sub> BATSHRT	V <sub>MINSYS</sub>
bq24160	6.5V	10.5V	D+/D-	Yes	JEITA	3.0V 50mA	3.5V
bq24160A	6.5V	10.5V	D+/D-	No	JEITA	3.0V 50mA	3.5V
bq24161	6.5V	10.5V	PSEL (0=1.5A, 1=100mA)	Yes	Standard	2.0V 50mA	3.5V
bq24161B	6.5V	10.5V	PSEL (0=1.5A, 1=500mA)	Yes	JEITA	3.0V 50mA	3.5V
bq24163	6.5V	10.5V	D+/D-	Yes	JEITA	2.0V 50mA	3.2V
bq24168	6.5V	6.5V	PSEL (0=1.5A, 1=100mA)	No	JEITA	2.0V 50mA	3.5V

- Each of the above are available in as YFF and RGE packages with the following options:  
R - tabed and reeled in quantities of 3,000 devices per reel.  
T - taped and reeled in quantities of 250 devices per reel.
- This product is RoHS compatible, including a lead concentration that does not exceed 0.1% of total product weight, and is suitable for use in specified lead-free soldering processes. In addition, this product uses package materials that do not contain halogens, including bromine (Br) or antimony (Sb) above 0.1% of total product weight.

## 7 Pin Configuration and Functions

**RGE Package**  
**VQFN 24 Pins**  
**Top View**

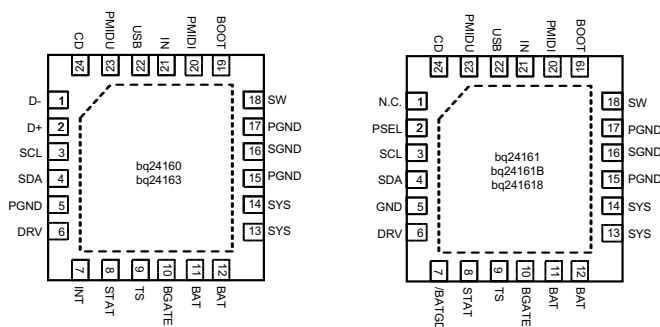

**YFF Package**  
**WCSP 49 Pins**  
**Top View**

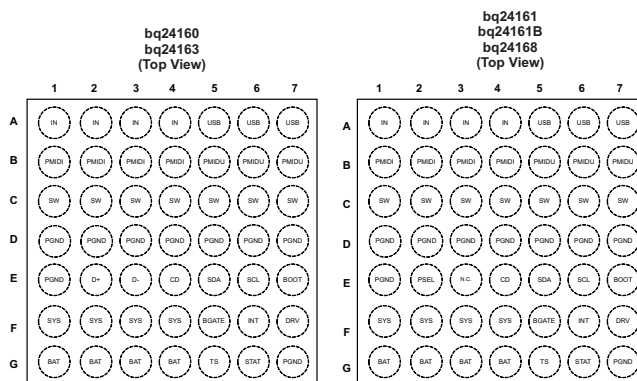

### Pin Functions

NAME	PIN				I/O	DESCRIPTION
	NO. bq24160, 3		NO. bq24161, 1B, 8			
	YFF	RGE	YFF	RGE		
BAT	G1-G4	11, 12	G1-G4	11, 12	I/O	<b>Battery Connection</b> – Connect to the positive terminal of the battery. Additionally, bypass BAT to GND with at least a 1µF capacitor.
BGATE	F5	10	F5	10	O	<b>External Discharge MOSFET Gate Connection</b> – BGATE drives an external P-Channel MOSFET to provide a very low-resistance discharge path. Connect BGATE to the gate of the external MOSFET. BGATE is low during high impedance mode and when no input is connected.
BOOT	E7	19	E7	19	I	<b>High Side MOSFET Gate Driver Supply</b> – Connect a 0.01µF ceramic capacitor (voltage rating > 10V) from BOOT to SW to supply the gate drive for the high side MOSFETs.
$\overline{\text{CD}}$	E4	24	E4	24	I	<b>IC Hardware Chip Disable Input</b> – Drive $\overline{\text{CD}}$ high to place the bq2416xx in high-z mode. Drive $\overline{\text{CD}}$ low for normal operation. Do not leave CD unconnected.
D+	E2	2	—	—	I	<b>D+ and D– Connections for USB Input Adapter Detection</b> – When a charge cycle is initiated by the USB input, and a short is detected between D+ and D–, the USB input current limit is set to 1.5A. If a short is not detected, the USB100 mode is selected. The D+/D– detection has no effect on the IN input.
D–	E3	1	—	—	I	
DRV	F7	6	F7	6	O	<b>Gate Drive Supply</b> – DRV is the bias supply for the gate drive of the internal MOSFETs. Bypass DRV to PGND with a 1µF ceramic capacitor. DRV may be used to drive external loads up to 10mA. DRV is active whenever the input is connected and $V_{\text{SUPPLY}} > V_{\text{UVLO}}$ and $V_{\text{SUPPLY}} > (V_{\text{BAT}} + V_{\text{SLP}})$
IN	A1- A4	21	A1- A4	21	I	<b>Input power supply</b> – IN is connected to the external DC supply (AC adapter or alternate power source). Bypass IN to PGND with at least a 1µF ceramic capacitor.
INT	F6	7	F6	7	O	<b>Status Output</b> – INT is an open-drain output that signals charging status and fault interrupts. INT pulls low during charging. INT is high impedance when charging is complete or the charger is disabled. When a fault occurs, a 128µs pulse is sent out as an interrupt for the host. INT is enabled/disabled using the EN_STAT bit in the control register. Connect INT to a logic rail through a 100kΩ resistor to communicate with the host processor.
PGND	D1-D7, E1, G7	5, 15, 16, 17	D1-D7, E1, G7	5, 15, 16, 17	—	<b>Ground terminal</b> – Connect to the thermal pad (for VQFN only) and the ground plane of the circuit.
PMIDI	B1-B4	20	B1-B4	20	O	<b>Reverse Blocking MOSFET and High Side MOSFET Connection Point for High Power Input</b> – Bypass PMIDI to GND with at least a 4.7µF ceramic capacitor. Use caution when connecting an external load to PMIDI. The PMIDI output is not current limited. Any short on PMIDI will damage the IC.
PMIDU	B5-B7	23	B5-B7	23	O	<b>Reverse Blocking MOSFET and High Side MOSFET Connection Point for USB Input</b> – Bypass PMIDU to GND with at least a 4.7µF ceramic capacitor. Use caution when connecting an external load to PMIDU. The PMIDU output is not current limited. Any short on PMIDU will damage the IC.
PSEL	—	—	E2	2		<b>USB Source Detection Input</b> – Drive PSEL high to indicate that a USB source is connected to the USB input. When PSEL is high, the IC starts up with a 100mA (bq24161/8) or 500mA (bq24161B) input current limit for USB. Drive PSEL low to indicate that an AC Adapter is connected to the USB input. When PSEL is low, the IC starts up with a 1.5A input current limit for USB. PSEL has no effect on the IN input. Do not leave PSEL unconnected.
SCL	E6	3	E6	3	I	<b>I<sup>2</sup>C Interface Clock</b> – Connect SCL to the logic rail through a 10kΩ resistor.
SDA	E5	4	E5	4	I/O	<b>I<sup>2</sup>C Interface Data</b> – Connect SDA to the logic rail through a 10kΩ resistor.
STAT	G6	8	G6	8	O	<b>Status Output</b> – STAT is an open-drain output that signals charging status and fault interrupts. STAT pulls low during charging. STAT is high impedance when charging is complete or the charger is disabled. When a fault occurs, a 128µs pulse is sent out as an interrupt for the host. STAT is enabled /disabled using the EN_STAT bit in the control register. Pull STAT up to a logic rail through an LED for visual indication or through a 10kΩ resistor to communicate with the host processor.
SW	C1-C7	18	C1-C7	18	O	<b>Inductor Connection</b> – Connect to the switched side of the external inductor.
SYS	F1-F4	13, 14	F1-F4	13,14	I	<b>System Voltage Sense and Charger FET Connection</b> – Connect SYS to the system output at the output bulk capacitors. Bypass SYS locally with at least 10µF. A 47µF bypass capacitor is recommended for optimal transient response.
TS	G5	9	G5	9	I	<b>Battery Pack NTC Monitor</b> – Connect TS to the center tap of a resistor divider from DRV to GND. The NTC is connected from TS to GND. The TS function provides 4 thresholds for JEITA compatibility (160, 161B, 163, 168 only). TS faults are reported by the I <sup>2</sup> C interface. See the <i>NTC Monitor</i> section for more details on operation and selecting the resistor values. Connect TS to DRV to disable the TS function.
USB	A5-A7	22	A5-A7	22	I	<b>USB Input Power Supply</b> – USB is connected to the external DC supply (AC adapter or USB port). Bypass USB to PGND with at least a 1µF ceramic capacitor.
Thermal Pad	—	Pad	—	Pad	—	There is an internal electrical connection between the exposed thermal pad and the PGND pin of the device. The thermal pad must be connected to the same potential as the PGND pin on the printed circuit board. Do not use the thermal pad as the primary ground input for the device. PGND pin must be connected to ground at all times.

## 8 Specifications

### 8.1 Absolute Maximum Ratings

over operating free-air temperature range (unless otherwise noted)<sup>(1)</sup>

		MIN	MAX	UNIT
Pin voltage range (with respect to VSS)	IN, USB	-2	20	V
	PMIDI, PMIDU, BOOT	-0.3	20	V
	SW	-0.7	12	V
	SDA, SCL, SYS, BAT, STAT, BGATE, DRV, TS, D+, D-, INT, PSEL, CD	-0.3	7	V
BOOT to SW		-0.3	7	V
Output current (Continuous)	SW	4.5		A
	SYS, BAT	3.5		A
Input current (Continuous)	IN	2.75		A
	USB	1.75		A
Output sink current	$\overline{\text{STAT}}$	10		mA
	INT	1		mA
Operating free-air temperature range		-40	85	°C
Junction temperature, T <sub>J</sub>		-40	125	°C
Lead temperature (soldering, 10 s)		300		°C

- (1) Stresses beyond those listed under absolute maximum ratings may cause permanent damage to the device. These are stress ratings only, and functional operation of the device at these or any other conditions beyond those indicated under recommended operating conditions is not implied. Exposure to absolute-maximum-rated conditions for extended periods may affect device reliability. All voltage values are with respect to the network ground terminal unless otherwise noted.

### 8.2 Handling Ratings

			MIN	MAX	UNIT
T <sub>stg</sub>	Storage temperature range		-65	150	°C
V <sub>(ESD)</sub>	Electrostatic discharge	Human body model (HBM), per ANSI/ESDA/JEDEC JS-001, all pins <sup>(1)</sup>		2	kV
		Charged device model (CDM), per JEDEC specification JESD22-C101, all pins <sup>(2)</sup>		500	V

- (1) JEDEC document JEP155 states that 500-V HBM allows safe manufacturing with a standard ESD control process.  
(2) JEDEC document JEP157 states that 250-V CDM allows safe manufacturing with a standard ESD control process.

### 8.3 Recommended Operating Conditions

over operating free-air temperature range (unless otherwise noted)

		MIN	MAX	UNIT
V <sub>IN</sub>	IN voltage range	4.2	18	V
	IN operating voltage range (bq24160/1/3)	4.2	10	
	IN operating voltage range (bq24168)	4.2	6	
V <sub>USB</sub>	USB voltage range	4.2	18	V
	USB operating range	4.2	6	
I <sub>IN</sub>	Input current, IN input		2.5	A
I <sub>USB</sub>	Input current USB input		1.5	A
I <sub>SYS</sub>	Output Current from SW, DC		3	A
I <sub>BAT</sub>	Charging		2.5	A
	Discharging, using internal battery FET		2.5	A
T <sub>J</sub>	Operating junction temperature range	0	125	°C

## 8.4 Thermal Information

THERMAL METRIC <sup>(1)</sup>		bq2416xx		UNIT
		49 PINS (YFF)	24 PINS (RGE)	
$\theta_{JA}$	Junction-to-ambient thermal resistance	49.8	32.6	°C/W
$\theta_{JCTop}$	Junction-to-case (top) thermal resistance	0.2	30.5	°C/W
$\theta_{JB}$	Junction-to-board thermal resistance	1.1	3.3	°C/W
$\psi_{JT}$	Junction-to-top characterization parameter	1.1	0.4	°C/W
$\psi_{JB}$	Junction-to-board characterization parameter	6.6	9.3	°C/W
$\theta_{JCbot}$	Junction-to-case (bottom) thermal resistance	n/a	2.6	°C/W

(1) For more information about traditional and new thermal metrics, see the IC Package Thermal Metrics application report, [SPRA953](#).

## 8.5 Electrical Characteristics

Circuit of [Figure 21](#),  $V_{SUPPLY} = V_{USB}$  or  $V_{IN}$  (whichever is supplying the IC),  $V_{UVLO} < V_{SUPPLY} < V_{OVP}$  and  $V_{SUPPLY} > V_{BAT} + V_{SLP}$ ,  $T_J = -40^\circ\text{C} - 125^\circ\text{C}$  and  $T_J = 25^\circ\text{C}$  for typical values (unless otherwise noted)

PARAMETER		TEST CONDITIONS	MIN	TYP	MAX	UNIT	
<b>INPUT CURRENTS</b>							
$I_{SUPPLY}$	Supply current for control ( $V_{IN}$ or $V_{USB}$ )	$V_{UVLO} < V_{SUPPLY} < V_{OVP}$ and $V_{SUPPLY} > V_{BAT} + V_{SLP}$	PWM switching	15		mA	
			PWM NOT switching	5			
		$0^\circ\text{C} < T_J < 85^\circ\text{C}$ , High-Z Mode	175		$\mu\text{A}$		
$I_{BATLEAK}$	Leakage current from BAT to the Supply	$0^\circ\text{C} < T_J < 85^\circ\text{C}$ , $V_{BAT} = 4.2\text{V}$ , $V_{USB} = V_{IN} = 0\text{V}$	5		$\mu\text{A}$		
$I_{BAT\_HIZ}$	Battery discharge current in High Impedance mode, (BAT, SW, SYS)	$0^\circ\text{C} < T_J < 85^\circ\text{C}$ , $V_{BAT} = 4.2\text{V}$ , $V_{SUPPLY} = 5\text{V}$ or $0\text{V}$ , SCL, SDA = 0 V or 1.8V, High-Z Mode	55		$\mu\text{A}$		
<b>POWER-PATH MANAGEMENT</b>							
$V_{SYS(REG)}$	System regulation voltage	Charge Enabled, $V_{BAT} < V_{MINSYS}$	bq24160, 1, 1B, 8	3.60	3.7	3.82	V
			bq24163	3.3	3.4	3.5	
		Battery FET turned off (Charge Disabled, TS Fault or Charging Terminated)		$V_{BATREG} + 1.5\%$	$V_{BATREG} + 3.0\%$	$V_{BATREG} + 4.17\%$	
$V_{MINSYS}$	Minimum system regulation voltage	Charge enabled, $V_{BAT} < V_{MINSYS}$ , Input current limit or $V_{INDPM}$ active	bq24160, 1, 1B, 8	3.4	3.5	3.62	V
			bq24163	3.1	3.2	3.3	V
$V_{BSUP1}$	Enter supplement mode threshold	$V_{BAT} > 2.5\text{V}$	$V_{BAT} - 30\text{mV}$			V	
$V_{BSUP2}$	Exit supplement mode threshold	$V_{BAT} > 2.5\text{V}$	$V_{BAT} - 10\text{mV}$			V	
$I_{LIM(dischrg)}$	Current limit, discharge or supplement mode	Current monitored in internal FET only.	7			A	
$t_{DGL(SC1)}$	Deglintch time, SYS short circuit during discharge or supplement mode	Measured from ( $V_{BAT} - V_{SYS}$ ) = 300mV to BAT high-impedance	250			$\mu\text{s}$	
$t_{REC(SC1)}$	Recovery time, SYS short circuit during discharge or supplement mode		60			ms	
	Battery range for BGATE and supplement mode operation		2.5	4.5		V	
<b>BATTERY CHARGER</b>							
$R_{ON(BAT-SYS)}$	Internal battery charger MOSFET on-resistance	Measured from BAT to SYS, $V_{BAT} = 4.2\text{V}$	YFF pkg	37	57	$\text{m}\Omega$	
			RGE pkg	50	70		
$V_{BATREG}$	Charge Voltage	Operating in voltage regulation, Programmable range	3.5	4.44		V	
	Voltage regulation accuracy		-1%	1%			
$I_{CHARGE}$	Fast charge current range	$V_{BATSHRT} \leq V_{BAT} < V_{BAT(REG)}$ programmable range	550	2500		mA	
	Fast charge current accuracy	$0^\circ\text{C}$ to $125^\circ\text{C}$	-10%	+10%			
$V_{BATSHRT}$	Battery short circuit threshold	100mV Hysteresis	bq24161, 3, 8	1.9	2.0	2.1	V
			bq24160, 1B	2.9	3.0	3.1	
$I_{BATSHRT}$	Battery short circuit current	$V_{BAT} < V_{BATSHRT}$	50			mA	
$t_{DGL(BATSHRT)}$	Deglintch time for battery short circuit to fastcharge transition		32			ms	
$I_{TERM}$	Termination charge current accuracy	$I_{TERM} = 50\text{mA}$	-35%	+35%			
		$I_{TERM} \geq 100\text{mA}$	-15%	+15%			
$t_{DGL(TERM)}$	Deglintch time for charge termination	Both rising and falling, 2mV overdrive, $t_{RISE}$ , $t_{FALL} = 100\text{ns}$	32			ms	
$V_{RCH}$	Recharge threshold voltage	Below $V_{BATREG}$	120			mV	
$t_{DGL(RCH)}$	Deglintch time	VBAT falling below VRCH, $t_{FALL} = 100\text{ns}$	32			ms	

## Electrical Characteristics (continued)

Circuit of Figure 21,  $V_{SUPPLY} = V_{USB}$  or  $V_{IN}$  (whichever is supplying the IC),  $V_{UVLO} < V_{SUPPLY} < V_{OVP}$  and  $V_{SUPPLY} > V_{BAT} + V_{SLP}$ ,  $T_J = -40^{\circ}\text{C} - 125^{\circ}\text{C}$  and  $T_J = 25^{\circ}\text{C}$  for typical values (unless otherwise noted)

PARAMETER		TEST CONDITIONS	MIN	TYP	MAX	UNIT	
$V_{DETECT}$	Battery detection threshold	During battery detection source cycle		3.3		V	
		During battery detection sink cycle		3.0			
$I_{DETECT}$	Battery detection current before charge done (sink current)	Termination enabled (EN_TERM = 1)		2.5		mA	
$t_{DETECT}$	Battery detection time	Termination enabled (EN_TERM = 1)		250		ms	
$V_{IH}$	PSEL, CD Input high logic level		1.3			V	
$V_{IL}$	PSEL, CD Input low logic level				0.4	V	
<b>INPUT CURRENT LIMITING</b>							
$I_{IN\_USB}$	Input current limit threshold (USB input)	USB charge mode, $V_{USB} = 5\text{V}$ , DC Current pulled from SW	$I_{USBLIM} = \text{USB100}$	90	95	100	mA
			$I_{USBLIM} = \text{USB500}$	450	475	500	
			$I_{USBLIM} = \text{USB150}$	135	142.5	150	
			$I_{USBLIM} = \text{USB900}$	800	850	900	
			$I_{USBLIM} = \text{USB800}$	700	750	800	
$I_{IN\_IN}$	Input current limit threshold (IN input)	IN charge mode, $V_{IN} = 5\text{V}$ , DC Current pulled from SW	$I_{INLIM} = 1.5\text{A}$	1.35	1.5	1.65	A
			$I_{INLIM} = 2.5\text{A}$	2.3	2.5	2.8	
$V_{IN\_DPM}$	Input based DPM threshold range	Charge mode, programmable via I <sup>2</sup> C, both inputs	4.2		4.76	V	
	$V_{IN\_DPM}$ threshold accuracy		-2		+2%		
<b>VDRV BIAS REGULATOR</b>							
$V_{DRV}$	Internal bias regulator voltage	$V_{SUPPLY} > 5.45\text{V}$	5	5.2	5.45	V	
$I_{DRV}$	DRV output current		10			mA	
$V_{DO\_DRV}$	DRV Dropout voltage ( $V_{SUPPLY} - V_{DRV}$ )	$I_{SUPPLY} = 1\text{A}$ , $V_{SUPPLY} = 5\text{V}$ , $I_{DRV} = 10\text{mA}$			450	mV	
<b>STATUS OUTPUT (STAT, INT)</b>							
$V_{OL}$	Low-level output saturation voltage	$I_O = 10\text{mA}$ , sink current			0.4	V	
$I_{IH}$	High-level leakage current	$V_{STAT} = V_{INT} = 5\text{V}$			1	$\mu\text{A}$	
<b>PROTECTION</b>							
$V_{UVLO}$	IC active threshold voltage	$V_{IN}$ rising	3.6	3.8	4	V	
$V_{UVLO\_HYS}$	IC active hysteresis	$V_{IN}$ falling from above $V_{UVLO}$	120	150		mV	
$V_{SLP}$	Sleep-mode entry threshold, $V_{SUPPLY} - V_{BAT}$	$2.0\text{V} \leq V_{BAT} \leq V_{BATREG}$ , $V_{IN}$ falling	0	40	100	mV	
$V_{SLP\_EXIT}$	Sleep-mode exit hysteresis	$2.0\text{V} \leq V_{BAT} \leq V_{BATREG}$	40	100	175	mV	
	Deglintch time for supply rising above $V_{SLP} + V_{SLP\_EXIT}$	Rising voltage, 2mV over drive, $t_{RISE} = 100\text{ns}$		30		ms	
$V_{BAD\_SOURCE}$	Bad source detection threshold	After Bad Source Detection completes		$V_{IN\_DPM} - 80\text{mV}$		V	
		During Bad Source Detection		$V_{IN\_DPM} + 80\text{mV}$		V	
$t_{DGL(BSD)}$	Deglintch on bad source detection			32		ms	
$V_{OVP}$	Input supply OVP threshold voltage	USB, $V_{USB}$ Rising	6.3	6.5	6.7	V	
		IN, $V_{IN}$ Rising (bq24160/1/1B/3)	10.3	10.5	10.7		
		IN, $V_{IN}$ Rising (bq24168)	6.3	6.5	6.7		
$V_{OVP(HYS)}$	$V_{OVP}$ hysteresis	Supply falling from $V_{OVP}$		100		mV	
$V_{BOVP}$	Battery OVP threshold voltage	$V_{BAT}$ threshold over $V_{OREG}$ to turn off charger during charge	$1.025 \times V_{BATREG}$	$1.05 \times V_{BATREG}$	$1.075 \times V_{BATREG}$	V	
		$V_{BOVP}$ hysteresis	Lower limit for $V_{BAT}$ falling from above $V_{BOVP}$		1		% of $V_{BATREG}$
$t_{DGL(BOVP)}$	Battery OVP deglintch	BOVP fault shown in register once $t_{DGL(BOVP)}$ expires. Buck converter shut down immediately when $V_{BAT} > V_{BATOVP}$		1		ms	
$V_{BATUVLO}$	Battery undervoltage lockout threshold	$V_{BAT}$ rising, 100mV hysteresis		2.5		V	
$I_{LIMIT}$	Cycle-by-cycle current limit	$V_{SYS}$ shorted	4.1	4.9	5.6	A	
$T_{SHDWN}$	Thermal trip			165		$^{\circ}\text{C}$	
	Thermal hysteresis			10			
$T_{REG}$	Thermal regulation threshold	Charge current begins to cut off		120		$^{\circ}\text{C}$	
	Safety timer accuracy	(bq24160/1/1B/3 Only)	-20%		20%		
<b>PWM</b>							
	Internal top reverse blocking MOSFET on-resistance	$I_{IN\_LIMIT} = 500\text{mA}$ , Measured from USB to PMIDU		95	175	m $\Omega$	
		$I_{IN\_LIMIT} = 500\text{mA}$ , Measured from IN to PMIDI		45	80		

## Electrical Characteristics (continued)

Circuit of [Figure 21](#),  $V_{\text{SUPPLY}} = V_{\text{USB}}$  or  $V_{\text{IN}}$  (whichever is supplying the IC),  $V_{\text{UVLO}} < V_{\text{SUPPLY}} < V_{\text{OVP}}$  and  $V_{\text{SUPPLY}} > V_{\text{BAT}} + V_{\text{SLP}}$ ,  $T_J = -40^\circ\text{C} - 125^\circ\text{C}$  and  $T_J = 25^\circ\text{C}$  for typical values (unless otherwise noted)

PARAMETER		TEST CONDITIONS	MIN	TYP	MAX	UNIT
	Internal top N-channel Switching MOSFET on-resistance	Measured from PMIDU to SW		100	175	mΩ
		Measured from PMIDI to SW		65	110	
	Internal bottom N-channel MOSFET on-resistance	Measured from SW to PGND		65	115	mΩ
$f_{\text{OSC}}$	Oscillator frequency		1.35	1.50	1.65	MHz
$D_{\text{MAX}}$	Maximum duty cycle			95%		
$D_{\text{MIN}}$	Minimum duty cycle		0%			
<b>BATTERY-PACK NTC MONITOR</b>						
$V_{\text{HOT}}$	High temperature threshold	$V_{\text{TS}}$ falling	29.7	30	30.5	% $V_{\text{DRV}}$
$V_{\text{HYS(HOT)}}$	Hysteresis on high threshold	$V_{\text{TS}}$ rising		1		
$V_{\text{WARM}}$	High temperature threshold	$V_{\text{TS}}$ falling	37.9	38.3	39.6	% $V_{\text{DRV}}$
$V_{\text{HYS(WARM)}}$	Hysteresis on high threshold	$V_{\text{TS}}$ rising		1		
$V_{\text{COOL}}$	Low temperature threshold	$V_{\text{TS}}$ falling	56	56.5	56.9	% $V_{\text{DRV}}$
$V_{\text{HYS(COOL)}}$	Hysteresis on low threshold	$V_{\text{TS}}$ rising		1		
$V_{\text{COLD}}$	Low temperature threshold	$V_{\text{TS}}$ falling	59.5	60	60.4	% $V_{\text{DRV}}$
$V_{\text{HYS(COLD)}}$	Hysteresis on low threshold	$V_{\text{TS}}$ rising		1		
$TS_{\text{OFF}}$	TS Disable threshold	$V_{\text{TS}}$ rising, 2% $V_{\text{DRV}}$ hysteresis	70		73	% $V_{\text{DRV}}$
$t_{\text{DGL(TS)}}$	Deglintch time on TS change			50		ms
<b>D+/D- DETECTION (bq24160)</b>						
$V_{\text{D+}_\text{SRC}}$	D+ Voltage Source		0.5	0.6	0.7	V
$I_{\text{D+}_\text{SRC}}$	D+ Connection Check Current Source		7		14	μA
$I_{\text{D-}_\text{SINK}}$	D- Current Sink		50	100	150	μA
$I_{\text{D-}_\text{LKG}}$	Leakage Current into D+/D-	D-, switch open	-1		1	μA
		D+, switch open	-1		1	μA
$V_{\text{D+}_\text{LOW}}$	D+ Low Comparator Threshold		0.8			V
$V_{\text{D-}_\text{LOWdatref}}$	D- Low Comparator Threshold		250		400	mV
$R_{\text{D-}_\text{DWN}}$	D- Pulldown for Connection Check		14.25		24.8	kΩ
<b>BATGD OPERATION</b>						
$V_{\text{BATGD}}$	Good Battery threshold		3.6	3.8	3.9	V
	Deglintch for good battery threshold	$V_{\text{BAT}}$ rising to HIGH-Z mode, DEFAULT Mode Only		32		ms
<b>I<sup>2</sup>C COMPATIBLE INTERFACE</b>						
$V_{\text{IH}}$	Input low threshold level	$V_{\text{PULL-UP}} = 1.8\text{V}$ , SDA and SCL	1.3			V
$V_{\text{IL}}$	Input low threshold level	$V_{\text{PULL-UP}} = 1.8\text{V}$ , SDA and SCL			0.4	V
$V_{\text{OL}}$	Output low threshold level	$I_{\text{L}} = 10\text{mA}$ , sink current			0.4	V
$I_{\text{BIAS}}$	High-Level leakage current	$V_{\text{PULL-UP}} = 1.8\text{V}$ , SDA and SCL		1		μA
$t_{\text{WATCHDOG}}$	Watchdog timer timeout	(bq24160/1/3 Only)	30			s

## 8.6 Typical Characteristics

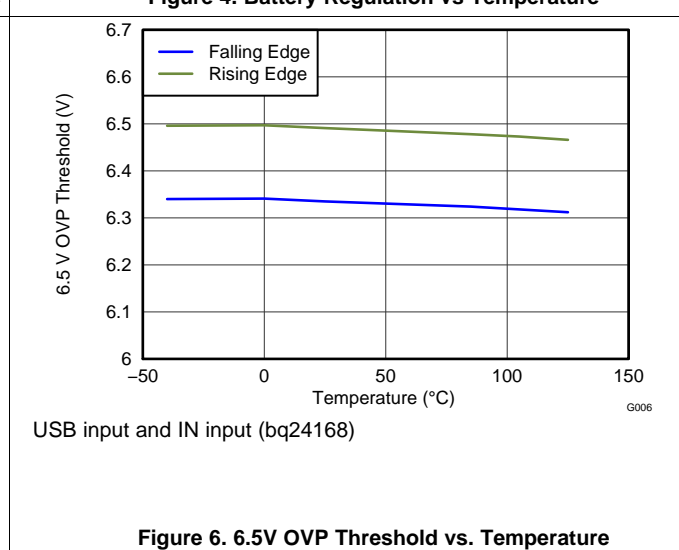
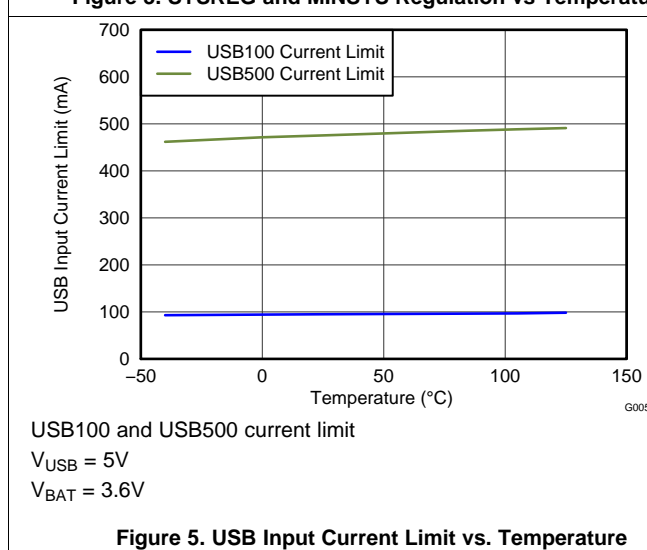
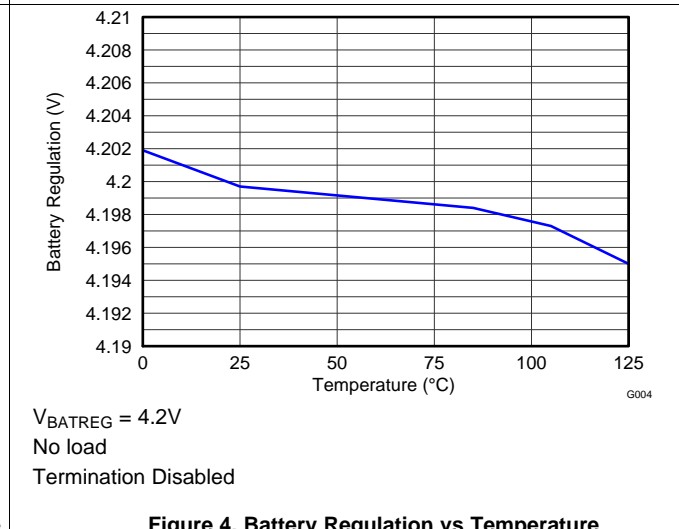
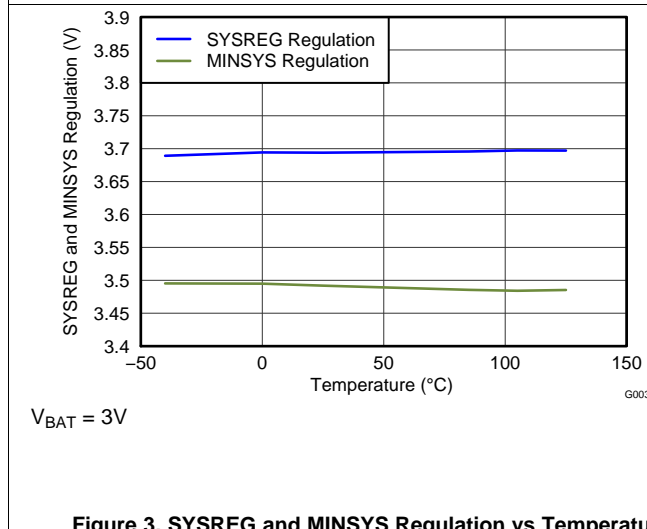
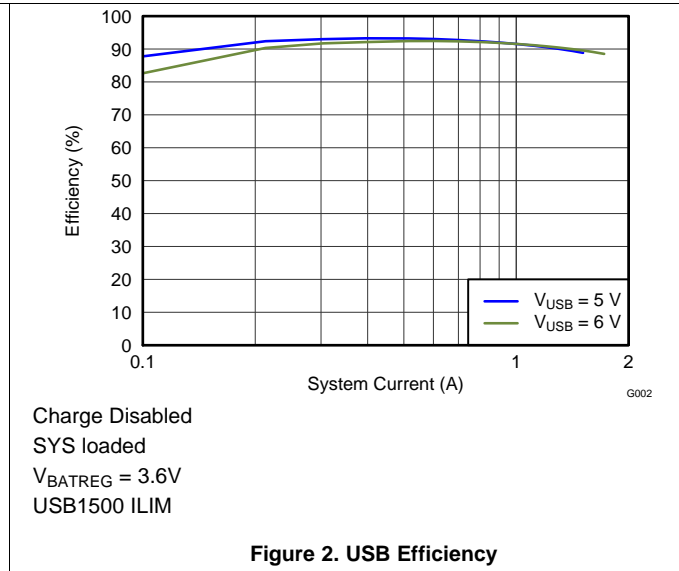
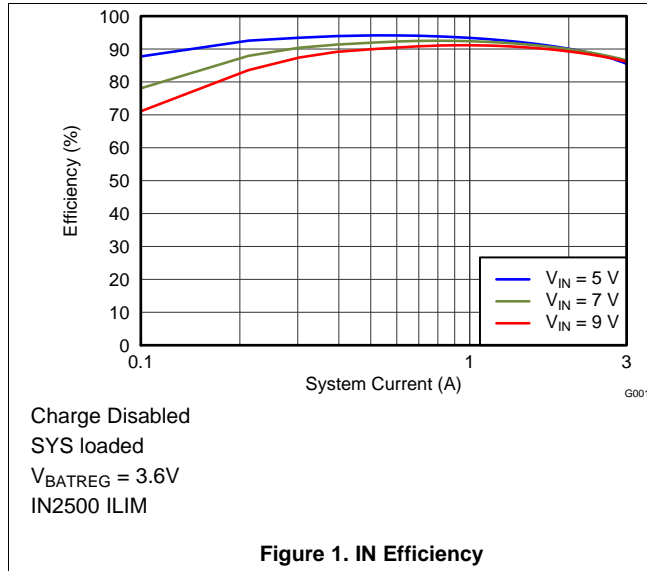

Typical Characteristics (continued)

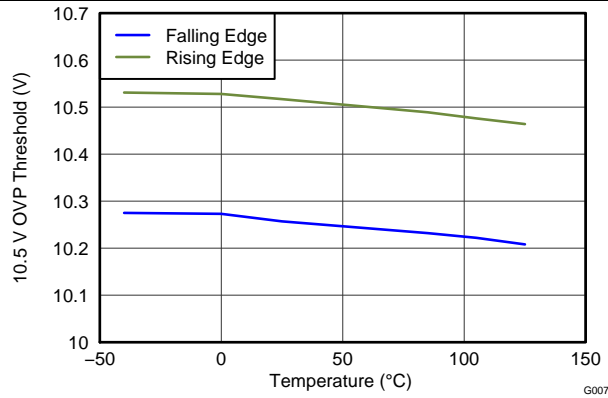
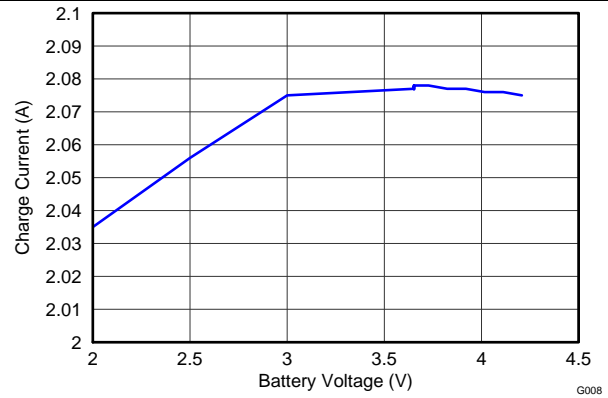

Figure 7. 10.5V OVP Threshold vs. Temperature



$I_{CHARGE} = 2A$   
 $V_{IN} = 5V$   
 $V_{BATREG} = 4.44V$

Figure 8. Charge Current vs. Battery Voltage

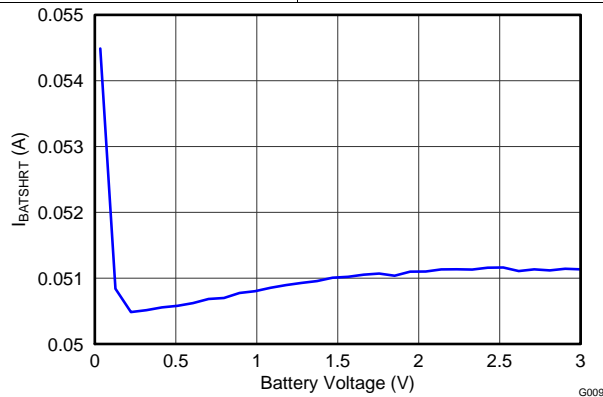

Figure 9.  $I_{BATSHRT}$  vs. Battery Voltage

## **9 Detailed Description**

### **9.1 Overview**

The bq24160/bq24160A/bq24161/bq24161B/bq24163/bq24168 devices are highly integrated single-cell Li-Ion battery chargers and system power path management devices targeted for space-limited, portable applications with high-capacity batteries. The dual-input, single-cell charger operates from either a USB port or alternate power source (that is, wall adapter or wireless power input) for a versatile solution.

The power path management feature allows the bq2416xx to power the system from a high-efficiency DC-DC converter while simultaneously and independently charging the battery. The charger monitors the battery current at all times and reduces the charge current when the system load requires current above the input current limit. This allows proper charge termination and enables the system to run with a defective or absent battery pack. Additionally, this enables instant system turnon even with a totally discharged battery or no battery. The power-path management architecture also permits the battery to supplement the system current requirements when the adapter cannot deliver the peak system currents. This enables the use of a smaller adapter. The 2.5-A current capability allows for GSM phone calls as soon as the adapter is plugged in regardless of the battery voltage. The charge parameters are programmable using the I<sup>2</sup>C interface.



## 9.3 Feature Description

### 9.3.1 Charge Mode Operation

#### 9.3.1.1 Charge Profile

The internal battery MOSFET is used to charge the battery. When the battery is above the MINSYS voltage, the internal FET is on to maximize efficiency and the PWM converter regulates the charge current into the battery. When battery is less than MINSYS, the SYS is regulated to  $V_{SYS(REG)}$  and battery is charged using the battery FET to regulate the charge current. There are 5 loops that influence the charge current:

- Constant current loop (CC)
- Constant voltage loop (CV)
- Thermal-regulation loop
- Minimum system-voltage loop (MINSYS)
- Input-voltage dynamic power-management loop ( $V_{IN}$ -DPM)

During the charging process, all five loops are enabled and the one that is dominant takes control. The bq2416xx supports a precision Li-Ion or Li-Polymer charging system for single-cell applications. The Dynamic Power Path Management (DPPM) feature regulates the system voltage to a minimum of  $V_{MINSYS}$ , so that startup is enabled even for a missing or deeply discharged battery. Figure 10 shows a typical charge profile including the minimum system output voltage feature.

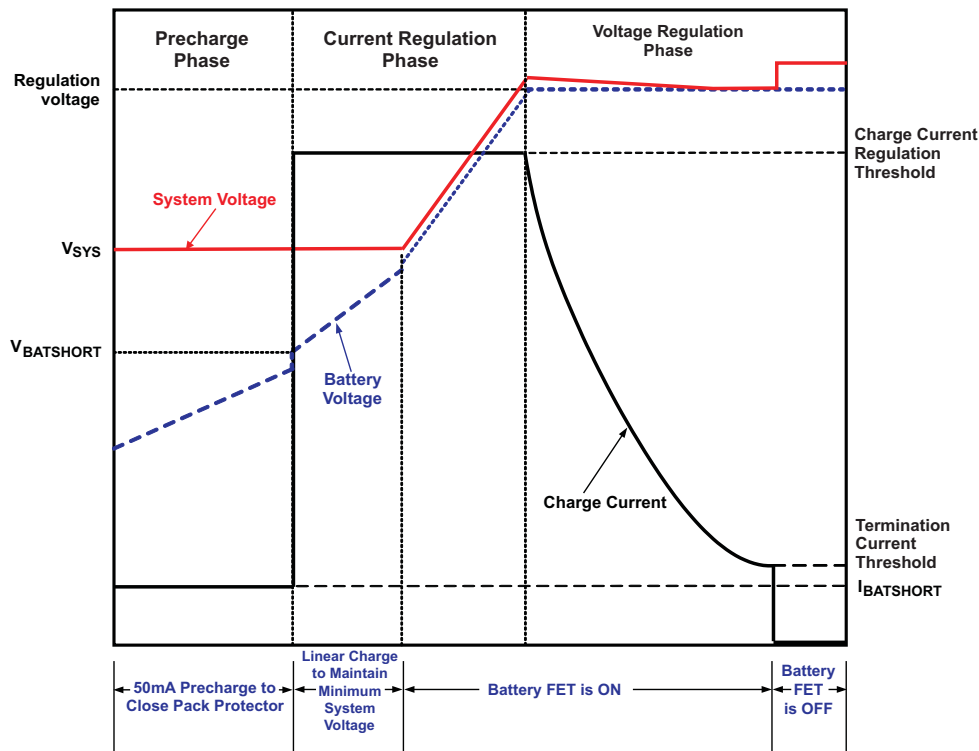

Figure 10. Typical bq2416xx Charging Profile

## Feature Description (continued)

### 9.3.1.2 PWM Controller in Charge Mode

The bq2416xx provides an integrated, fixed-frequency 1.5MHz voltage-mode controller to power the system and supply the charge current. The voltage loop is internally compensated and provides enough phase margin for stable operation, allowing the use of small ceramic capacitors with low ESR. When starting up, the bq2416xx uses a "soft-start" function to help limit inrush current. When coming out of High Impedance mode, the bq2416xx starts up with the input current limit set to 40% of the value programmed in the I<sup>2</sup>C register. After 80ms, the input current limit threshold steps up in 256μs steps. The steps are 40% to 50%, then 50% to 60%, then 60% to 70%, then 70% to 80%, and finally 80% to 100%. After the final step, soft start is complete and will not be restarted until the bq2416xx enters High Impedance mode.

The input scheme for the bq2416xx prevents battery discharge when the supply voltages are lower than V<sub>BAT</sub> and also isolates the two inputs from each other. The high-side N-MOSFET (Q1/Q2) switches to control the power delivered to the output. The DRV LDO provides a supply for the gate drive for the low side MOSFET, while a bootstrap circuit (BST) with an external bootstrap capacitor is used to boost up the gate drive voltage for Q1 and Q2.

Both inputs are protected by a cycle-by-cycle current limit that is sensed through the high-side MOSFETs for Q1 and Q2. The threshold for the current limit is set to a nominal 5A peak current. The inputs also utilize an input current limit that limits the current from the power source.

### 9.3.2 Battery Charging Process

Assuming a valid input source is attached to IN or USB, as soon as a deeply discharged or shorted battery is attached to the BAT pin, ( $V_{BAT} < V_{BATSHRT}$ ), the bq2416xx applies I<sub>BATSHRT</sub> to close the pack protector switch and bring the battery voltage up to acceptable charging levels. During this time, the battery FET is linearly regulated and the system output is regulated to V<sub>SYS(REG)</sub>. Once the battery rises above V<sub>BATSHRT</sub>, the charge current is regulated to the value set in the I<sup>2</sup>C register. The battery FET is linearly regulated to maintain the system voltage at V<sub>SYS(REG)</sub>. Under normal conditions, the time spent in this region is a very short percentage of the total charging time, so the linear regulation of the charge current does not affect the overall charging efficiency for very long. If the die temperature does rise, the thermal regulation circuit reduces the charge current to maintain a die temperature less than 120°C. If the current limit for the SYS output is reached (limited by the input current limit, or V<sub>IN\_DPM</sub>), the SYS output drops to the V<sub>MINSYS</sub> output voltage. When this happens, the charge current is reduced to provide the system with all the current that is needed while maintaining the minimum system voltage. If the charge current is reduced to 0mA, pulling further current from SYS causes the output to fall to the battery voltage and enter supplement mode. (See the [Dynamic Power Path Management](#) section for more details.)

Once the battery is charged enough so that the system voltage begins to rise above V<sub>SYS(REG)</sub>, the battery FET is turned on fully and the battery is charged with the full programmed charge current set by the I<sup>2</sup>C interface, I<sub>CHARGE</sub>. The slew rate for the fast-charge current is controlled to minimize current and voltage overshoot during transients. The charge current is regulated to I<sub>CHARGE</sub> until the battery is charged to the regulation voltage. As the battery voltage rises above VRCH, the battery regulation loop is activated. This may result in a small step down in the charge current as the loops transition between the charge current and charge voltage loops. As the battery voltage charges up to the regulation voltage, V<sub>BATREG</sub>, the charge current is tapered down as shown in [Figure 10](#) while the SYS output remains connected to the battery. The voltage between the BAT and PGND pins is regulated to V<sub>BATREG</sub>. The bq2416xx is a fixed single-cell voltage version, with adjustable regulation voltage (3.5V to 4.44V), programmed using the I<sup>2</sup>C interface.

The bq2416xx monitors the charging current during the voltage-regulation phase. If the battery voltage is above the recharge threshold and the charge current has naturally tapered down to and remains below termination threshold, I<sub>TERM</sub>, (without disturbance from events like supplement mode) for 32ms, the charger terminates charge, turns off the battery charging FET and enters battery detection. Termination is disabled when the charge current is reduced by a loop other than the voltage regulation loop or the input current limit is set to 100 mA. For example, when the bq2416xx is in half charge due to TS function, reverse boost protection is active, LOW\_CHG bit is set, or the thermal regulation, V<sub>INDPM</sub> or input current loops are active, termination will not occur. This prevents false termination events. During termination, the system output is regulated to the V<sub>SYS(REG)</sub> and supports the full current available from the input and the battery supplement mode is available. (See the [Dynamic](#)

## Feature Description (continued)

([Power Path Management](#) section for more details.) The termination current level is programmable. When setting the termination threshold less than 150mA, the reverse boost protection may trip falsely with load transients and very fully charged batteries. This will prevent termination while in the reverse boost protection and may extend charge time. To disable the charge current termination, the host sets the charge termination bit (TE) of charge control register to 0, refer to I<sup>2</sup>C section for details.

A new charge cycle is initiated if  $\overline{CD}$  is low when either

1.  $V_{SUPPLY}$  rises above UVLO while a battery with  $V_{BAT} < V_{BATREG} - V_{RCH}$  is attached or
2. a battery with  $V_{BAT} < V_{BATREG} - V_{RCH}$  is attached while  $V_{SUPPLY}$  is above UVLO.

With  $V_{SUPPLY}$  above UVLO and  $V(BAT) < V_{BOVP}$ , a recharge cycle is initiated when one of the following conditions is detected:

1. The battery voltage falls below the  $V_{BAT(REG)} - V_{RCH}$  threshold.
2.  $\overline{CE}$  bit toggle or RESET bit toggle
3. Supplement mode event occurs
4.  $\overline{CD}$  pin or HI-Z bit toggle

$V_{BAT(REG)}$  should never be programmed less than  $V_{BAT}$ . If the battery is ever 5% above the regulation threshold, the battery OVP circuit shuts the PWM converter off immediately and the battery FET is turned on to discharge the battery to safe operating levels. If the battery OVP condition exists for the 1ms deglitch, a battery OVP fault is reported in the I<sup>2</sup>C status registers. The battery OVP fault is cleared when the battery voltage discharges below  $V_{RCH}$  or if the IC enters hi-impedance mode (HZ\_MODE=1 or CD=1). Always write bq2416xx to high impedance mode before changing  $V_{BATREG}$  to clear BOVP condition to ensure proper operation.

If the battery voltage is ever greater than  $V_{BATREG}$  (for example, when an almost fully charged battery enters the JEITA WARM state due to the TS pin) but less than  $V_{BOVP}$ , the reverse boost protection circuitry may activate as explained later in this datasheet. If the battery is ever above  $V_{BOVP}$ , the buck converter turns off and the internal battery FET is turned on. This prevents further overcharging of the battery and allows the battery to discharge to safe operating levels. The battery OVP event does not clear until the battery voltage falls below  $V_{RCH}$ .

### 9.3.3 Battery Detection

When termination conditions are met, a battery detection cycle is started. During battery detection,  $I_{DETECT}$  is pulled from  $V_{BAT}$  for  $t_{DETECT}$  to verify there is a battery. If the battery voltage remains above  $V_{DETECT}$  for the full duration of  $t_{DETECT}$ , a battery is determined to present and the IC enters "Charge Done". If  $V_{BAT}$  falls below  $V_{DETECT}$ , a "Battery Not Present" fault is signaled and battery detection continues. The next cycle of battery detection, the bq2416xx turns on  $I_{BATSHORT}$  for  $t_{DETECT}$ . If  $V_{BAT}$  rises to  $V_{DETECT}$ , the current source is turned off and after  $t_{DETECT}$ , the battery detection continues through another current sink cycle. Battery detection continues until charge is disabled or a battery is detected. Once a battery is detected, the fault status clears and a new charge cycle begins. Battery detection is not run when termination is disabled.

### 9.3.4 Dynamic Power Path Management (DPPM)

The bq2416xx features a SYS output that powers the external system load connected to the battery. This output is active whenever a source is connected to IN, USB or BAT. The following sections discuss the behavior of SYS with a source connected to the supply or a battery source only.

### 9.3.5 Input Source Connected

When a valid input source is connected to IN or USB and the bq2416xx is NOT in High Impedance mode, the buck converter enters soft-start and turns on to power the load on SYS. The STAT/INT pin outputs a 128 $\mu$ s interrupt pulse to alert the host that an input has been connected. The FAULT bits indicate a normal condition, and the Supply Status register indicates that a new supply is connected. The  $\overline{CE}$  bit (bit 1) in the control register (0x02) indicates whether a charge cycle is initiated. By default, the bq2416xx ( $\overline{CE}=0$ ) enables a charge cycle when a valid input source is connected. When the  $\overline{CE}$  bit is '1' and a valid input source is connected, the battery FET is turned off and the SYS output is regulated to the  $V_{SYS(REG)}$  programmed by the  $V_{BATREG}$  threshold in the I<sup>2</sup>C register. A charge cycle is initiated when the  $\overline{CE}$  bit is written to a 0 value (cleared).

## Feature Description (continued)

When the  $\overline{CE}$  bit is a 0 and a valid source is connected to IN or USB, the buck converter starts up using soft-start. A charge cycle is initiated 64ms after the buck converter initiates startup. When  $V_{BAT}$  is high enough that  $V_{SYS} > V_{SYS(REG)}$ , the battery FET is turned on and the SYS output is connected to BAT. If the SYS voltage falls to  $V_{SYS(REG)}$ , it is regulated to that point to maintain the system output even with a deeply discharged or absent battery. In this mode, the SYS output voltage is regulated by the buck converter and the battery FET linearly regulates the charge current into the battery. The current from the supply is shared between charging the battery and powering the system load at SYS. The dynamic power-path management (DPPM) circuitry of the bq2416xx monitors the current limits continuously, and if the SYS voltage falls to the  $V_{MINSYS}$  voltage, it adjusts charge current to maintain the minimum system voltage and supply the load on SYS. If the charge current is reduced to zero and the load increases further, the bq2416xx enters battery-supplement mode. During supplement mode, the battery FET is turned on and the battery supplements the system load.

When an input is connected with no battery attached and termination enabled, the startup process proceeds as normal until the termination deglitch times out. After this, the bq2416xx enters battery detection and waits for a battery to be connected. Once a battery is connected and passes battery detection, a new charge cycle begins. Once the battery is applied, the HZMODE bit or  $\overline{CD}$  pin must be toggled before writing the BATREG to a higher voltage and beginning a new charge cycle. Failure to do this can result in SYS unexpectedly regulating to 15% above  $V_{BATREG}$ .

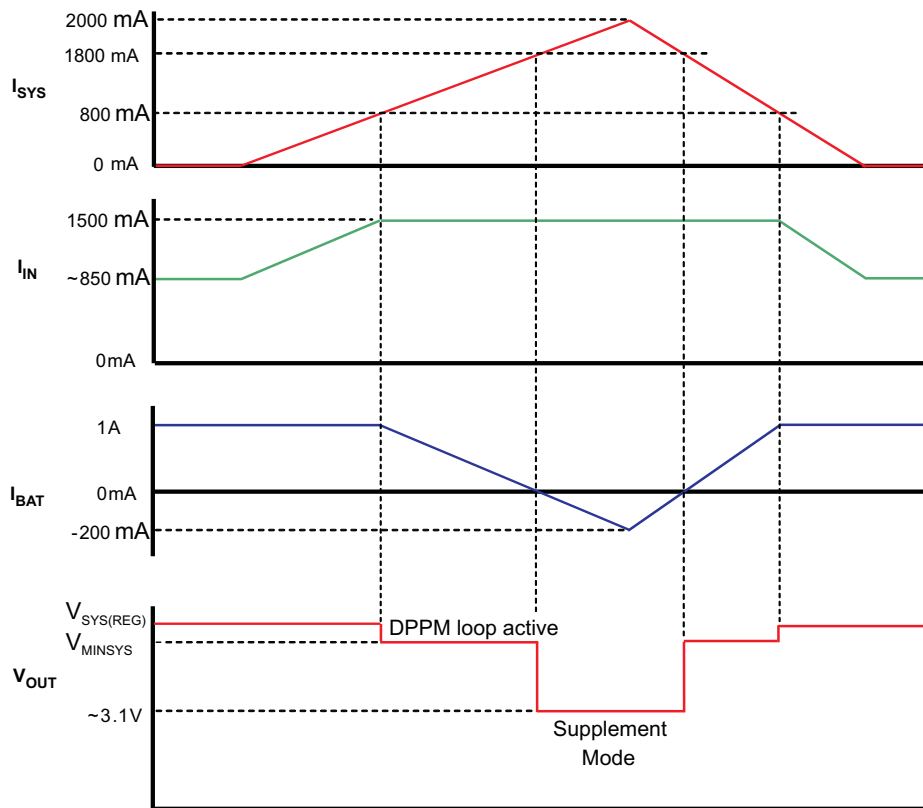

Figure 11. Example DPPM Response ( $V_{Supply}=5V$ ,  $V_{BAT} = 3.1V$ , 1.5A Input Current Limit)

## Feature Description (continued)

### 9.3.6 Battery Only Connected

When a battery with voltage greater than  $V_{BATUVLO}$  is connected with no input source, the battery FET is turned on similar to supplement mode. In this mode, the current is not regulated; however, there is a short circuit current limit. If the short circuit limit is reached, the battery FET is turned off for the deglitch time ( $t_{DGL(SC1)}$ ). After the recovery time ( $t_{REC(SC1)}$ ), the battery FET is turned on to test and see if the short has been removed. If it has not, the FET turns off and the process repeats until the short is removed. This process is to protect the internal FET from over current. If an external FET is used for discharge, the external FET's body diode prevents the load on SYS from being disconnected from the battery. If the battery voltage is less than  $V_{BATUVLO}$ , the internal battery FET (Q4) remains off and BAT is high-impedance. This prevents further discharging of deeply-discharged batteries.

### 9.3.7 Battery Discharge FET (BGATE)

The bq2416xx contains a MOSFET driver to drive the gate of an external discharge FET between the battery and the system output. This external FET provides a low impedance path when supplying the system from the battery. Connect BGATE to the gate of the external discharge MOSFET. BGATE is on under the following conditions:

1. No input supply connected.
2.  $\overline{HZ\_MODE}$  bit = 1
3.  $\overline{CD}$  pin = 1

### 9.3.8 DEFAULT Mode

DEFAULT mode is used when I<sup>2</sup>C communication is not available. DEFAULT mode is entered in the following situations:

1. When the charger is enabled and  $V_{BAT} < V_{BATGD}$  before I<sup>2</sup>C communication is established
2. When the watchdog timer expires without a reset from the I<sup>2</sup>C interface and the safety timer has not expired.
3. When the device comes out of any fault condition (sleep mode, OVP, faulty adapter mode, etc.) before I<sup>2</sup>C communication is established

In DEFAULT mode, the I<sup>2</sup>C registers are reset to the default values. The 27-minute safety timer (no timer for bq24168) is reset and starts when DEFAULT mode is entered. The default value for VBATREG is 3.6V, and the default value for I<sub>CHARGE</sub> is 1A. The input current limit for the IN input is set to 1.5A. The input current limit for the USB input is determined by the D+/D– detection (bq24160/3) or PSEL (bq24161/1B/8). PSEL and D+/D– detection have no effect on the IN input. Default mode is exited by programming the I<sup>2</sup>C interface. Once I<sup>2</sup>C communication is established, PSEL has no effect on the USB input. Note that if termination is enabled and charging has terminated, a new charge cycle is NOT initiated when entering DEFAULT mode.

### 9.3.9 Safety Timer and Watchdog Timer (bq24160/ bq24161/ bq24161B/ bq24163 only)

At the beginning of charging process, the bq24160/1/1B/3 starts the safety timer. This timer is active during the entire charging process. If charging has not terminated before the safety timer expires, charging is disabled, the charge parameters are reset to the default values and the  $\overline{CE}$  bit is written to a "1". The length of the safety timer is selectable using the I<sup>2</sup>C interface. A single 128 $\mu$ s pulse is sent on the STAT and INT outputs and the STATx bits of the status registers are updated in the I<sup>2</sup>C. In DEFAULT mode, the safety timer can be reset and a new charge cycle initiated by input supply power on reset, removing/inserting battery or toggling the  $\overline{CD}$  pin. In HOST mode, the  $\overline{CE}$  bit is set to a '1' when the safety timer expires. The  $\overline{CE}$  bit must be cleared to a '0' in order to resume charging and clear the safety timer fault. The safety timer duration is selectable using the TMR\_X bits in the Safety Timer Register/ NTC Monitor register. Changing the safety timer duration resets the safety timer. This function prevents continuous charging of a defective battery. During the fast charge (CC) phase, several events increase the timer duration by 2X if the EN\_2X\_TMR bit is set in the register.

1. The system load current reduces the available charging current.
2. The input current needed for the fast charge current is limited by the input current loop.
3. The input current is reduced because the VINDPM loop is preventing the supply from crashing.
4. The device has entered thermal regulation because the IC junction temperature has exceeded TJ(REG).
5. The LOW\_CHG bit is set.

**Feature Description (continued)**

- 6. The battery voltage is less than VBATSHORT.
- 7. The battery has entered the JEITA WARM or COLD state via the TS pin

During these events, the timer is slowed by half to extend the timer and prevent any false timer faults. Starting a new charge cycle by VSUPPLY POR or removing/replacing the battery or resuming a charge by toggling the CE or HZ\_MODE bits, resets the safety timer. Additionally, thermal shutdown events cause the safety timer to reset.

In addition to the safety timer, the bq24160/1/1B/3 contain a watchdog timer that monitors the host through the I<sup>2</sup>C interface. Once a read/write is performed on the I<sup>2</sup>C interface, a 30-second timer ( $t_{WATCHDOG}$ ) is started. The 30-second timer is reset by the host using the I<sup>2</sup>C interface. This is done by writing a "1" to the reset bit (TMR\_RST) in the control register. The TMR\_RST bit is automatically set to "0" when the 30-second timer is reset. This process continues until the battery is fully charged or the safety timer expires. If the 30-second timer expires, the IC enters DEFAULT mode where the default register values are loaded, the safety timer restarts at 27 minutes and charging continues. The I<sup>2</sup>C may be accessed again to reinitialize the desired values and restart the watchdog timer. The watchdog timer flow chart is shown in Figure 12.

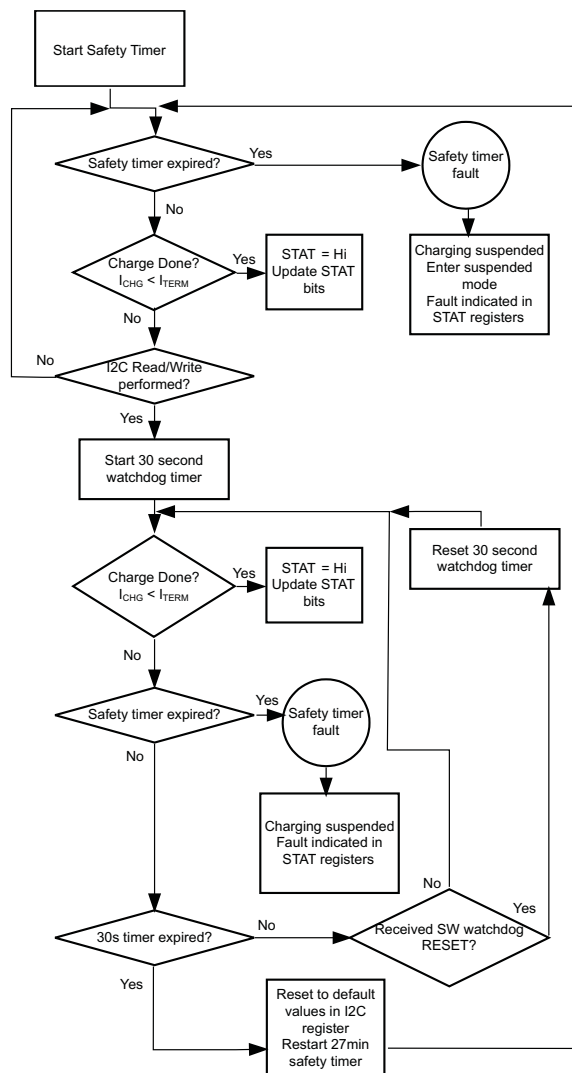

**Figure 12. The Watchdog Timer Flow Chart for bq2416xx**

## Feature Description (continued)

### 9.3.10 D+, D– Based Adapter Detection for the USB Input (D+, D–, bq24160/0A/3)

The bq24160/0A/3 contain a D+, D– based adapter detection circuit that is used to program the input current limit for the USB input during DEFAULT mode. D+, D– detection is only performed in DEFAULT mode unless forced by the D+, D–\_EN bit in host mode. Writing to register 2 during detection stops the detection routine.

By default the USB input current limit is set to 100mA. When a voltage higher than UVLO is applied to the USB input, the bq24160/0A/3 performs a charger source identification to determine if it is connected to an SDP (USB port) or CDP/DCP (dedicated charger). The first step is D+, D– line connection detection as described in BC1.2. Primary detection begins 10ms after the connection detection complete. The primary detection complies with the method described in BC1.2. During primary detection, the D+, D– lines are tested to determine if the port is an SDP or CDP/DCP. If a CDP/DCP is detected the input current limit is increased to 1.5A, if an SDP is detected the current limit remains at 100mA, until changed via the I<sup>2</sup>C interface. These two steps require at least 90ms to complete but if they have not completed within 500ms, the D+, D– detection routine selects 100mA for the unknown input source. Secondary detection as described in BC1.2 is not performed.

Automatic detection is performed only if  $V_{D+}$  and  $V_{D-}$  are less than 0.6V to avoid interfering with the USB transceiver which may also perform D+, D– detection when the system is running normally. However, D+, D– can be initiated at any time by the host by setting the D+, D– EN bit in the Control/Battery Voltage Register to 1. After detection is complete the D+, D– EN bit is automatically reset to 0 and the detection circuitry is disconnected from the D+, D– pins to avoid interference with USB data transfer.

When a command is written to change the input current limit in the I<sup>2</sup>C, this overrides the current limit selected by D+/D– detection. D+, D– detection has no effect on the IN input.

### 9.3.11 USB Input Current Limit Selector Input (PSEL, bq24161/ 161B/ 168 only)

The bq24161, bq24161B, and bq24168 contain a PSEL input that is used to program the input current limit for USB during DEFAULT mode. Drive PSEL high to indicate that a USB source is connected to the USB input and program the 100mA (bq24161/8) or 500mA (bq24161B) current limit for USB. Drive PSEL low to indicate that an AC Adapter is connected to the USB input. When PSEL is low, the IC starts up with a 1.5A current limit for USB. PSEL has no effect on the IN input. Once an I<sup>2</sup>C write is done, the PSEL has no effect on the input current limit until the watchdog timer expires.

### 9.3.12 Hardware Chip Disable Input ( $\overline{CD}$ )

The bq2416xx contains a  $\overline{CD}$  input that is used to disable the IC and place the bq2416xx into high-impedance mode. Drive  $\overline{CD}$  low to enable charge and enter normal operation. Drive  $\overline{CD}$  high to disable charge and place the bq2416xx into high-impedance mode. Driving  $\overline{CD}$  high during DEFAULT mode resets the safety timer. Driving  $\overline{CD}$  high during HOST mode resets the safety timer and places the bq2416xx into high impedance mode. The  $\overline{CD}$  pin has precedence over the I<sup>2</sup>C control.

### 9.3.13 LDO Output (DRV)

The bq2416xx contains a linear regulator (DRV) that is used to supply the internal MOSFET drivers and other circuitry. Additionally, DRV supplies up to 10mA external loads to power the STAT LED or the USB transceiver circuitry. The maximum value of the DRV output is 5.45V; ideal for protecting voltage sensitive USB circuits from high voltage fluctuations in the supply. The LDO is on whenever a supply is connected to the IN or USB inputs of the bq2416xx. The DRV is disabled under the following conditions:

1.  $V_{SUPPLY} < UVLO$
2.  $V_{SUPPLY} < V_{SLP}$
3. Thermal Shutdown

## Feature Description (continued)

### 9.3.14 External NTC Monitoring (TS)

The I<sup>2</sup>C interface allows the user to easily implement the JEITA standard for systems where the battery pack thermistor is monitored by the host. Additionally, the bq2416xx provides a flexible, voltage based TS input for monitoring the battery pack NTC thermistor. The voltage at TS is monitored to determine that the battery is at a safe temperature during charging. The bq24160, bq24160A, bq24161B, bq24163, and bq24168 enable the user to easily implement the JEITA standard for charging temperature while the bq24161 only monitors the hot and cold cutoff temperatures and leaves the JEITA control to the host. The JEITA specification is shown in.

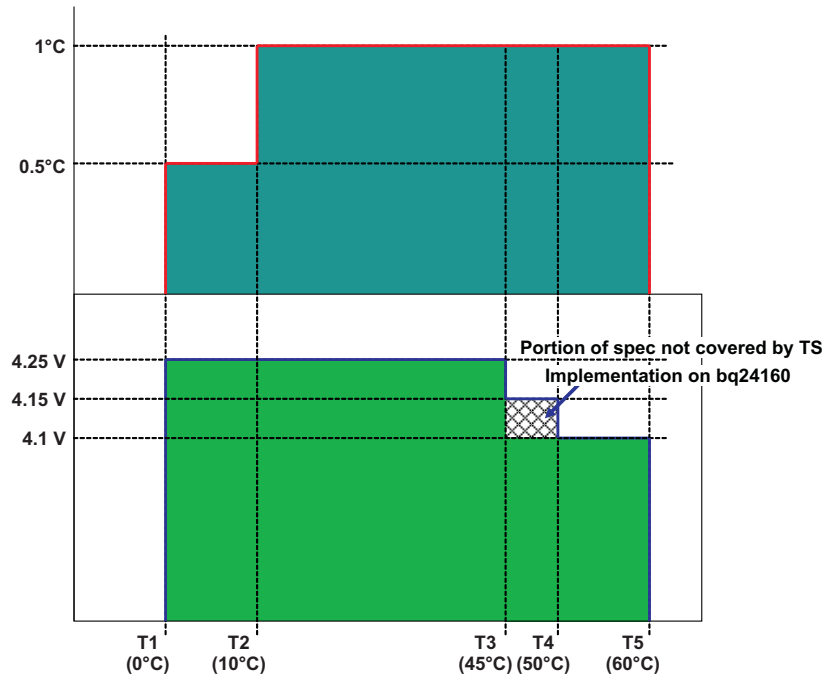

Figure 13. Charge Current During TS Conditions

To satisfy the JEITA requirements, four temperature thresholds are monitored; the cold battery threshold ( $T_{NTC} < 0^{\circ}\text{C}$ ), the cool battery threshold ( $0^{\circ}\text{C} < T_{NTC} < 10^{\circ}\text{C}$ ), the warm battery threshold ( $45^{\circ}\text{C} < T_{NTC} \leq 60^{\circ}\text{C}$ ) and the hot battery threshold ( $T_{NTC} > 60^{\circ}\text{C}$ ). These temperatures correspond to the  $V_{COLD}$ ,  $V_{COOL}$ ,  $V_{WARM}$ , and  $V_{HOT}$  thresholds. Charging is suspended and timers are suspended when  $V_{TS} < V_{HOT}$  or  $V_{TS} > V_{COLD}$ . When  $V_{WARM} > V_{TS} > V_{HOT}$ , the battery regulation voltage is reduced by 140mV from the programmed regulation threshold. When  $V_{COLD} > V_{TS} > V_{COOL}$ , the charging current is reduced to half of the programmed charge current.

The TS function is voltage based for maximum flexibility. Connect a resistor divider from DRV to GND with TS connected to the center tap to set the threshold. The connections are shown in Figure 20. The resistor values are calculated using the following equations:

$$RLO = \frac{V_{DRV} \times RCOLD \times RHOT \times \left[ \frac{1}{V_{COLD}} - \frac{1}{V_{HOT}} \right]}{RHOT \times \left[ \frac{V_{DRV}}{V_{HOT}} - 1 \right] - RCOLD \times \left[ \frac{V_{DRV}}{V_{COLD}} - 1 \right]} \quad (1)$$

$$RHI = \frac{\frac{V_{DRV}}{V_{COLD}} - 1}{\frac{1}{RLO} + \frac{1}{RCOLD}} \quad (2)$$

Where:

$$V_{COLD} = 0.60 \times V_{DRV}$$

## Feature Description (continued)

$$V_{HOT} = 0.30 \times V_{DRV}$$

Where  $R_{HOT}$  is the NTC resistance at the hot temperature and  $R_{COLD}$  is the NTC resistance at cold temperature.

For the bq24160, bq24161B, bq24163, and bq24168, the WARM and COOL thresholds are not independently programmable. The COOL and WARM NTC resistances for a selected resistor divider are calculated using the following equations:

$$R_{COOL} = \frac{R_{LO} \times 0.564 \times R_{HI}}{R_{LO} - R_{LO} \times 0.564 - R_{HI} \times 0.564} \quad (3)$$

$$R_{WARM} = \frac{R_{LO} \times 0.383 \times R_{HI}}{R_{LO} - R_{LO} \times 0.383 - R_{HI} \times 0.383} \quad (4)$$

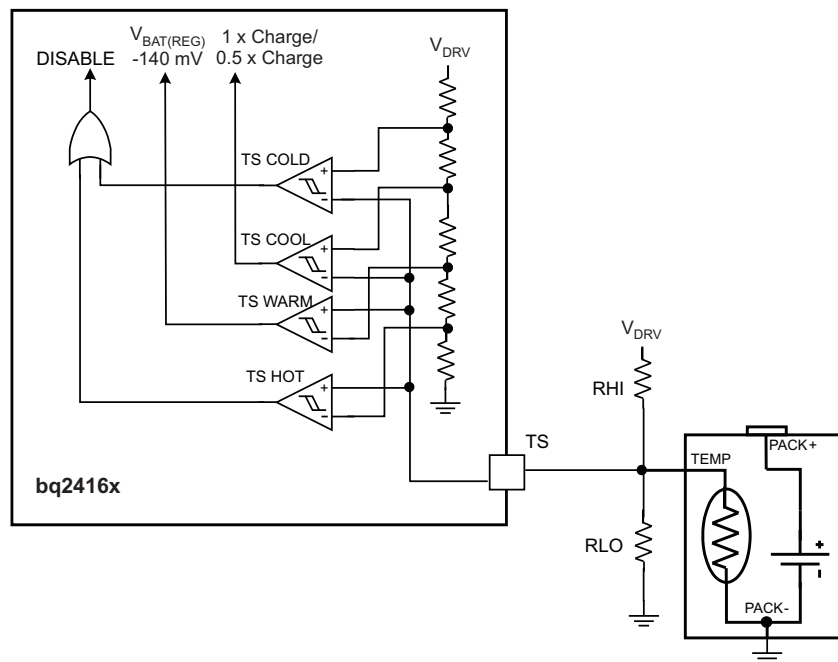

Figure 14. TS Circuit

### 9.3.15 Thermal Regulation and Protection

During the charging process, to prevent chip overheating, the bq2416xx monitors the junction temperature,  $T_J$ , of the die and begins to taper down the charge current once  $T_J$  reaches the thermal regulation threshold,  $T_{REG}$ . The charge current is reduced to zero when the junction temperature increases about  $10^\circ\text{C}$  above  $T_{REG}$ . Once the charge current is reduced, the system current is reduced while the battery supplements the load to supply the system. This may cause a thermal shutdown of the bq2416xx if the die temperature rises too high. At any state, if  $T_J$  exceeds  $T_{SHTDWN}$ , the bq2416xx suspends charging and disables the buck converter. During thermal shutdown mode, the buck converter is turned off, all timers are suspended, and a single  $128\mu\text{s}$  pulse is sent on the STAT and INT outputs and the STAT<sub>x</sub> and FAULT<sub>x</sub> bits of the status registers are updated in the I<sup>2</sup>C. A new charging cycle begins when  $T_J$  falls below  $T_{SHTDWN}$  by approximately  $10^\circ\text{C}$ .

## Feature Description (continued)

### 9.3.16 Input Voltage Protection in Charge Mode

#### 9.3.16.1 Sleep Mode

The bq2416xx enters the low-power sleep mode if the voltage on  $V_{SUPPLY}$  falls below the sleep-mode entry threshold,  $V_{BAT}+V_{SLP}$ , and  $V_{SUPPLY}$  is higher than the undervoltage lockout threshold,  $V_{UVLO}$ . This feature prevents draining the battery during the absence of  $V_{SUPPLY}$ . When  $V_{SUPPLY} < V_{BAT}+V_{SLP}$ , the bq2416xx turns off the PWM converter, turns the battery FET on and drives BGATE to GND, sends a single 128 $\mu$ s pulse on the STAT and INT outputs and updates the STATx and FAULT\_x bits in the status registers. Once  $V_{SUPPLY} > V_{BAT}+V_{SLP}$ , the STATx and FAULT\_x bits are cleared and the device initiates a new charge cycle.

#### 9.3.16.2 Input Voltage Based DPM

During normal charging process, if the input power source is not able to support the programmed or default charging current, the supply voltage decreases. Once the supply drops to  $V_{IN\_DPM}$  (default 4.2V for both inputs), the input current limit is reduced to prevent further supply droop. When the IC enters this mode, the charge current is lower than the set value and the DPM\_STATUS bit is set (Bit 5 in Register 05H). This feature provides IC compatibility with adapters with different current capabilities without a hardware change. Figure 15 shows the  $V_{IN\_DPM}$  behavior to a current-limited source. In this figure the input source has a 750mA current limit and the charging is set to 750mA. The SYS load is then increased to 1.2A.

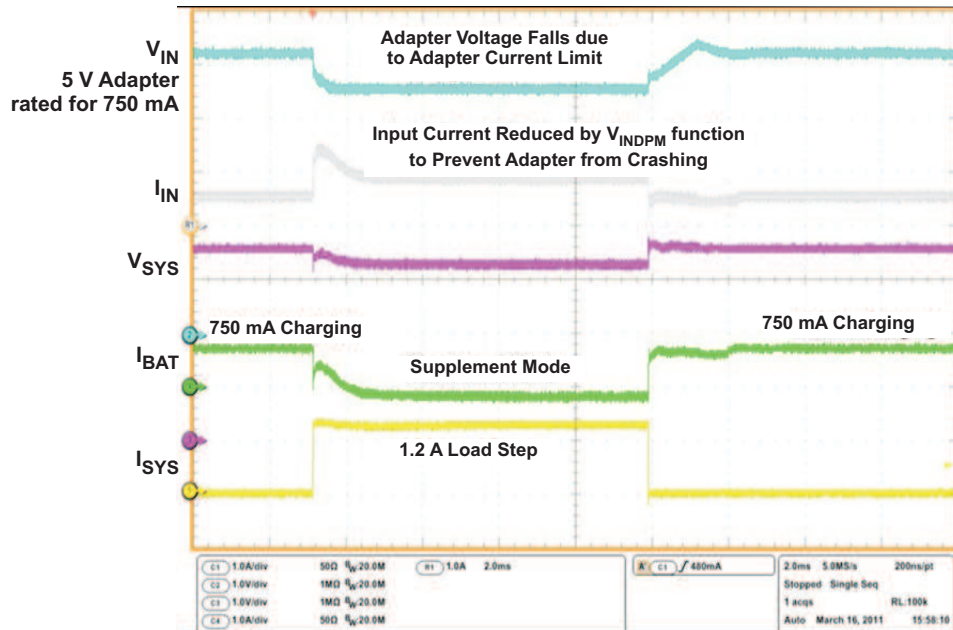

Figure 15. bq24160  $V_{IN\_DPM}$

#### 9.3.16.3 Bad Source Detection

When a source is connected to IN or USB, the bq2416xx runs a Bad Source Detection procedure to determine if the source is strong enough to provide some current to charge the battery. A current sink is turned on (30mA for USB input, 75mA for the IN input) for 32ms. If the source is valid after the 32ms ( $V_{BAD\_SOURCE} < V_{SUPPLY} < V_{OVP}$ ), the buck converter starts up and normal operation continues. If the supply voltage falls below  $V_{BAD\_SOURCE}$  during the detection, the current sink shuts off for two seconds and then retries, a single 128 $\mu$ s pulse is sent on the STAT and INT outputs and the STATx and FAULT\_x bits of the status registers and the battery/supply status registers are updated. The detection circuits retry continuously until either a new source is connected to the other input or a valid source is detected after the detection time. If during normal operation the source falls to  $V_{BAD\_SOURCE}$ , the bq2416xx turns off the PWM converter, turns the battery FET on, sends a single 128 $\mu$ s pulse is sent on the STAT and INT outputs and the STATx and FAULT\_x bits of the status registers, and the battery/supply status registers are updated. Once a good source is detected, the STATx and FAULT\_x bits are cleared and the device returns to normal operation.

## Feature Description (continued)

If two supplies are connected, the supply with precedence is checked first. If the supply detection fails once, the device switches to the other supply for two seconds and then retries. This allows the priority supply to settle if the connection was jittery or the supply ramp was too slow to pass detection. If the priority supply fails the detection a second time, it is locked out and lower priority supply is used. Once the bad supply is locked out, it remains locked out until the supply voltage falls below UVLO. This prevents continuously switching between a weak supply and a good supply.

### 9.3.16.4 Input Overvoltage Protection

The built-in input overvoltage protection to protect the device and other downstream components against damage from overvoltage on the input supply (Voltage from  $V_{USB}$  or  $V_{IN}$  to PGND). During normal operation, if  $V_{SUPPLY} > V_{OVP}$ , the bq2416xx turns off the PWM converter, turns the battery FET and BGATE on, sends a single 128 $\mu$ s pulse is sent on the STAT and INT outputs and the STATx and FAULT\_x bits of the status registers and the battery/supply status registers are updated. Once the OVP fault is removed, the STATx and FAULT\_x bits are cleared and the device returns to normal operation.

To allow operation with some unregulated adapters, the OVP circuit is not active during Bad Source Detection. This provides some time for the current sink to pull the unregulated adapter down into an acceptable range. If the adapter voltage is high at the end of the detection, the startup of the PWM converter does not occur. The OVP circuit is active during normal operation, so if the system standby current plus the charge current is not enough to pull down the source, operation is suspended.

### 9.3.16.5 Reverse Boost (Boost Back) Prevention Circuit

A buck converter has two operating modes, continuous conduction mode (CCM) and discontinuous conduction mode (DCM). In DCM, the inductor current ramps down to zero during the switching cycle while in CCM the inductor maintains a DC level of current. Transitioning from DCM to CCM during load transients, slows down the converter's transient response for those load steps, which can result in the SYS rail drooping. To achieve the fastest possible transient response for this charger, this charger's synchronous buck converter is forced to run in CCM even at light loads when the buck converter would typically revert to DCM. The challenge that presents itself when forcing CCM with a charger is that the output of the buck converter now has a power source. Thus, if the battery voltage,  $V(BAT)$ , is ever greater than  $V_{BATREG}$ , the inductor current goes fully negative and pushes current back to the input supply. This effect causes the input source voltage to rise if the input source cannot sink current. The input over-voltage protection circuit protects the IC from damage however some input sources may be damaged if the voltage rises. To prevent this, this charger has implemented a reverse boost prevention circuit. When reverse current is sensed that is not a result of the supplement comparator tripping, this circuit disables the internal battery FET and changes the feedback point to  $V_{SYSREG}$  for 1 ms. After the 1-ms timeout, the BATHFET is turned on again and the battery is tested to see if it is higher than  $V_{BATREG}$  (negative current). The reverse current protection is only active when  $V_{BOVP} > V_{BAT} > V_{BATREG} - V_{RCH}$ . Having  $V_{BOVP} > V_{BAT} > V_{BATREG} - V_{RCH}$  results in an approximately 100-mV, 1000-Hz ripple on SYS as seen in . The most common trigger for reverse boost prevention is a load transient on SYS that requires the charger to enter battery supplement mode.

When the IC enters reverse boost prevention, the IC stops charging or exits charge done which may result in the battery never reaching full charge. With termination enabled and  $ITERM > 150mA$  or with a high line impedance to the battery, the likelihood of activating the reverse boost prevention circuit is small and even when activated, the charger typically exits reverse boost prevention as the battery relaxes. With termination enabled and  $ITERM < 150mA$  or with a low impedance battery, the likelihood of activating the reverse boost prevention circuit by a load transient or even the inductor ripple current is higher. In either case, the IC resumes charging until  $V_{BAT}$  drops below  $V_{BATREG} - V_{RCH}$ , resulting in the battery always charging to at least 0.97 of full charge. If full charge is required with  $ITERM < 150mA$  then the recommended solution to ensure full charge is as follows

1. SET the charger's enable no battery operation bit (  $EN\_NOBATOP$  ) = 1 to disable the reverse boost prevention circuits. Brief, low-amplitude voltage pulses on IN may be observed as the IC enters boost back to resolve instances where  $V_{BAT}$  is greater than the  $V_{BATREG}$ , for example when exiting supplement mode. The I2C communication software must ensure that  $V_{BATREG}$  is never written below  $V_{BAT}$ . The IC automatically rewrites the  $V_{BATREG}$  register to the default value of 3.6V when existing HOST mode. For JEITA enabled ICs, the IC automatically lowers the voltage reference to 0.98 of the  $V_{BATREG}$  value. The software must account for these instances as well.
2. Disable the charger's termination function and TS functions and use a gas gauge to control termination and TS through its independent voltage and current measurements.

Feature Description (continued)

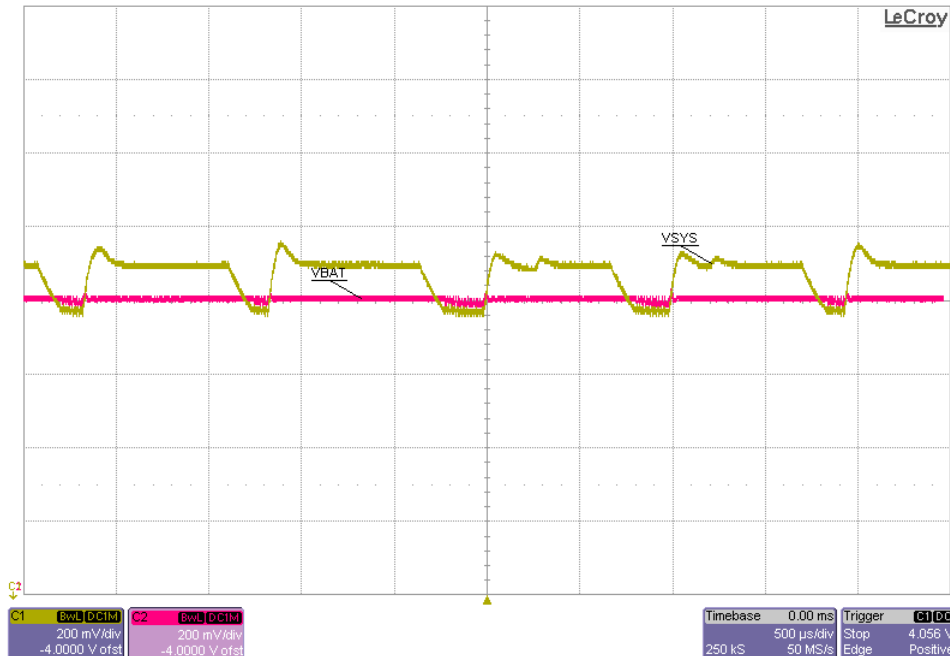

Figure 16. V(SYS) when Reverse Boost Prevention Circuit is Active

9.3.17 Charge Status Outputs (STAT, INT)

The STAT output is used to indicate operation conditions for bq2416xx. STAT is pulled low during charging when EN\_STAT bit in the control register (0x02h) is set to “1”. When charge is complete or disabled, STAT is high impedance. When a fault occurs, a 128- $\mu$ s pulse (interrupt) is sent out to notify the host. The status of STAT during different operation conditions is summarized in Table 1. STAT drives an LED for visual indication or can be connected to the logic rail for host communication. The EN\_STAT bit in the control register (00H) is used to enable/disable the charge status for STAT. The interrupt pulses are unaffected by EN\_STAT and will always be shown. The INT output is identical to STAT and is used to interface with a low voltage host processor.

Table 1. STAT Pin Summary

Charge State	STAT and INT behavior
Charge in progress and EN_STAT=1	Low
Other normal conditions	High-Impedance
Status Changes: Supply Status Change (plug in or removal), safety timer fault, watchdog expiration, sleep mode, battery temperature fault (TS), battery fault (OVP or absent), thermal shutdown	128- $\mu$ s pulse, then High Impedance

9.3.18 Good Battery Monitor

The bq2416xx contains a good battery monitor circuit that places the bq2416xx into high-z mode if the battery voltage is above the BATGD threshold while in DEFAULT mode. This function is used to enable compliance to the battery charging standard that prevents charging from an un-enumerated USB host while the battery is above the good battery threshold. If the bq2416xx is in HOST mode, it is assumed that USB host has been enumerated and the good battery circuit has no effect on charging.

## 9.4 Device Functional Modes

The state machine of the bq2416x automatically changes primary states (Off, sleep, HiZ, charge disabled, charging, charge done, battery OVP, fault) based on data in the I<sup>2</sup>C registers, IN and USB pin voltages, BAT pin voltage and current flow, TS pin voltage, CD pin voltage and status of the safety timer. The BAT and TS pin voltages as well as current flow into the IN and USB pins, out of SYS pin and into/out of the BAT pin determine the charging sub-states, including conditioning, constant current (CC), CC with reduced charge current, constant voltage (CV) with reduced charge current.

## 9.5 Programming

### 9.5.1 Serial Interface Description

The bq2416xx uses an I<sup>2</sup>C-compatible interface to program charge parameters. I<sup>2</sup>C is a 2-wire serial interface developed by Philips Semiconductor (see I<sup>2</sup>C-Bus Specification, Version 2.1, January 2000). The bus consists of a data line (SDA) and a clock line (SCL) with pull-up structures. When the bus is idle, both SDA and SCL lines are pulled high. All I<sup>2</sup>C-compatible devices connect to the I<sup>2</sup>C bus through open drain I/O pins, SDA and SCL. A master device, usually a microcontroller or a digital signal processor, controls the bus. The master is responsible for generating the SCL signal and device addresses. The master also generates specific conditions that indicate the START and STOP of data transfer. A slave device receives and/or transmits data on the bus under control of the master device.

The bq2416xx device works as a slave and supports the following data transfer modes, as defined in the I<sup>2</sup>C Bus Specification: standard mode (100kbps) and fast mode (400kbps). The interface adds flexibility to the battery charging solution, enabling most functions to be programmed to new values depending on the instantaneous application requirements. Register contents remain intact as long as battery voltage remains above 2.5V (typical). The I<sup>2</sup>C circuitry is powered from VBUS when a supply is connected. If the VBUS supply is not connected, the I<sup>2</sup>C circuitry is powered from the battery through BAT. The battery voltage must stay above 2.5V with no input connected in order to maintain proper operation.

The data transfer protocol for standard and fast modes is exactly the same; therefore, they are referred to as the F/S-mode in this document. The bq2416xx devices only support 7-bit addressing. The device 7-bit address is defined as '1101011' (6Bh).

#### 9.5.1.1 F/S Mode Protocol

The master initiates data transfer by generating a start condition. The start condition is when a high-to-low transition occurs on the SDA line while SCL is high, as shown in Figure 17. All I<sup>2</sup>C-compatible devices should recognize a start condition.

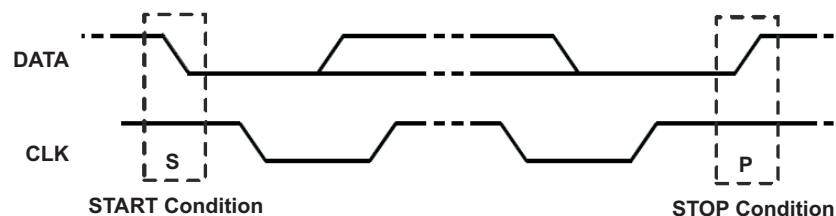

Figure 17. START and STOP Condition

The master then generates the SCL pulses, and transmits the 8-bit address and the read/write direction bit R/W on the SDA line. During all transmissions, the master ensures that data is valid. A valid data condition requires the SDA line to be stable during the entire high period of the clock pulse (see Figure 18). All devices recognize the address sent by the master and compare it to their internal fixed addresses. Only the slave device with a matching address generates an acknowledge (see Figure 19) by pulling the SDA line low during the entire high period of the ninth SCL cycle. Upon detecting this acknowledge, the master knows that communication link with a slave has been established.

## Programming (continued)

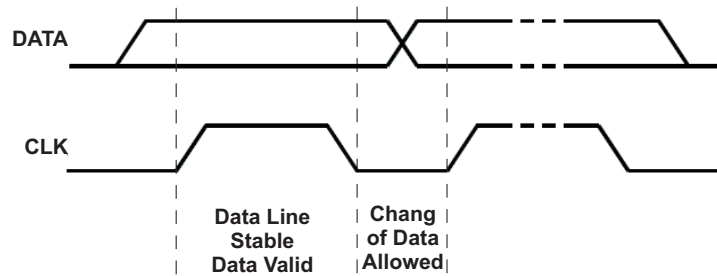

Figure 18. Bit Transfer on the Serial Interface

The master generates further SCL cycles to either transmit data to the slave (R/W bit 1) or receive data from the slave (R/W bit 0). In either case, the receiver needs to acknowledge the data sent by the transmitter. So an acknowledge signal can either be generated by the master or by the slave, depending on which one is the receiver. The 9-bit valid data sequences consisting of 8-bit data and 1-bit acknowledge can continue as long as necessary. To signal the end of the data transfer, the master generates a stop condition by pulling the SDA line from low to high while the SCL line is high (see Figure 20). This releases the bus and stops the communication link with the addressed slave. All I<sup>2</sup>C compatible devices must recognize the stop condition. Upon the receipt of a stop condition, all devices know that the bus is released, and wait for a start condition followed by a matching address. If a transaction is terminated prematurely, the master needs sending a STOP condition to prevent the slave I<sup>2</sup>C logic from remaining in an incorrect state. Attempting to read data from register addresses not listed in this section result in FFh being read out.

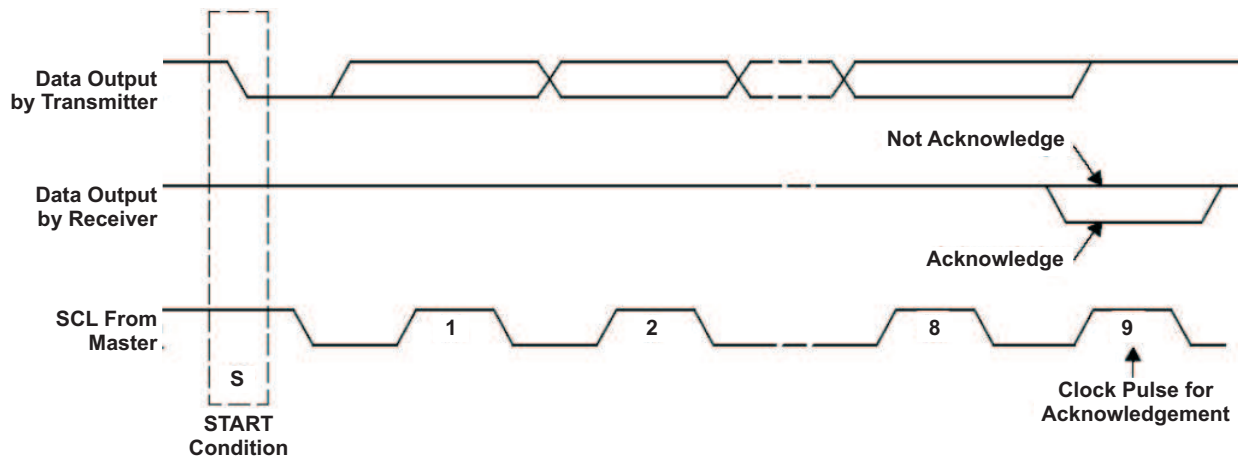

Figure 19. Acknowledge on the I2C Bus

## Programming (continued)

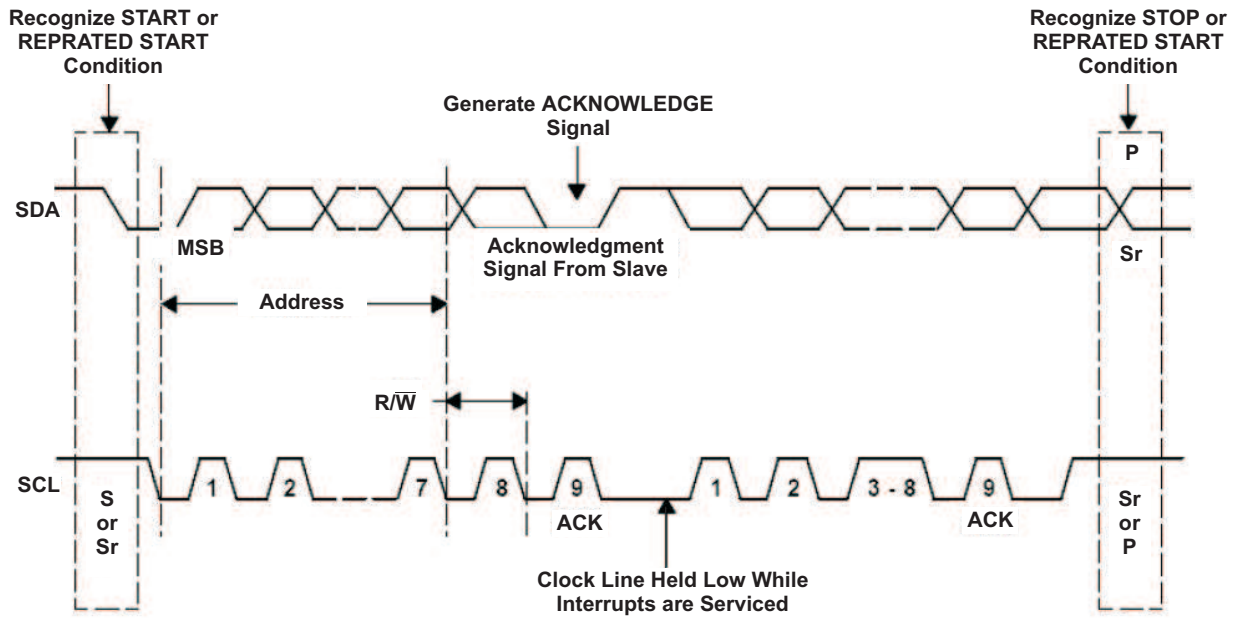

Figure 20. Bus Protocol

## 9.6 Register Maps

### 9.6.1 Status/Control Register (READ/WRITE)

Memory location: 00, Reset state: 0xxx 0xxx

BIT	NAME	Read/Write	FUNCTION
B7 (MSB)	TMR_RST	Read/Write	Write: TMR_RST function, write “1” to reset the watchdog timer (auto clear) Read: Always 0 (bq24160/1/3 only)
B6	STAT_2	Read only	000- No Valid Source Detected 001- IN Ready (shows preferred source when both connected) 010- USB Ready (shows preferred source when both connected) 011- Charging from IN 100- Charging from USB 101- Charge Done 110- NA 111- Fault
B5	STAT_1	Read only	
B4	STAT_0	Read only	
B3	SUPPLY_SEL	Read/Write	0-IN has precedence when both supplies are connected 1-USB has precedence when both supplies are connected (default 0)
B2	FAULT_2	Read only	000-Normal 001- Thermal Shutdown 010- Battery Temperature Fault 011- Watchdog Timer Expired (bq24160/1/1B/3 only) 100- Safety Timer Expired (bq24160/1/1B/3 only) 101- IN Supply Fault 110- USB Supply Fault 111- Battery Fault
B1	FAULT_1	Read only	
B0 (LSB)	FAULT_0	Read only	

#### SUPPLY\_SEL Bit (Supply Precedence Selector)

The SUPPLY\_SEL bit selects which supply has precedence when both supplies are present. In cases where both supplies are connected, they must remain isolated from each other which means only one is allowed to charge the battery. Write a “1” to SUPPLY\_SEL to select the USB input to have precedence. Write a “0” to select the IN input. Note the following behavior when switching the SUPPLY\_SEL bit with both supplies attached:

- The bq2416xx returns to high impedance mode
- The input supply is switched
- The bq2416xx begins a full startup cycle starting with bad adapter detection then proceeding to soft-start

Similarly, if charging from the non-preferred supply when the preferred supply is attached, the bq2416xx follows the same procedure.

#### STAT\_x and FAULT\_x Bits

The STAT\_x show the current status of the device and are updated dynamically as the IC changes state. The FAULT\_x bits show faults that have occurred and are only cleared by reading the bits, assuming the fault no longer exists. If multiple faults occur, the first one is the one that is shown.

### 9.6.2 Battery/ Supply Status Register (READ/WRITE)

Memory location: 01, Reset state: xxxx 0xxx

BIT	NAME	Read/Write	FUNCTION
B7 (MSB)	INSTAT1	Read Only	00-Normal 01-Supply OVP 10-Weak Source Connected (No Charging) 11- $V_{IN} < V_{UVLO}$
B6	INSTAT0	Read Only	
B5	USBSTAT1	Read Only	
B4	USBSTAT0	Read Only	00-Normal 01-Supply OVP 01-Weak Source Connected (No Charging) 11- $V_{USB} < V_{UVLO}$

BIT	NAME	Read/Write	FUNCTION
B3	OTG_LOCK	Read/Write	0 – No OTG supply present. Use USB input as normal. 1 – OTG supply present. Lockout USB input for charging. (default 0)
B2	BATSTAT1	Read Only	00-Battery Present and Normal
B1	BATSTAT0	Read Only	01-Battery OVP 10-Battery Not Present 11- NA
B0 (LSB)	EN_NOBATOP	Read/ Write	0-Normal Operation 1-Enables No Battery Operation when termination is disabled (default 0)

### OTG\_LOCK Bit (USB Lockout)

The OTG\_LOCK bit is used to prevent any charging from USB input regardless of the SUPPLY\_SEL bit and IN supply status. For systems using OTG supplies, it is not desirable to charge from an OTG source. Doing so would mean draining the battery by allowing it to effectively charge itself. Write a “1” to OTG\_LOCK to lock out the USB input. Write a “0” to OTG\_LOCK to return to normal operation. During OTG lock, the USB input is ignored and DRV does not come up. The watchdog timer must be reset while in USB\_LOCK to maintain the USB lockout state. This prevents the USB input from being permanently locked out for cases where the host loses I2C communication with OTG\_LOCK set (i.e., discharged battery from OTG operation). See the *Safety Timer and Watchdog Timer* section for more details.

### EN\_NOBATOP (No Battery Operation)

The EN\_NOBATOP bit enables no battery operation. When using the bq2416x without a battery attached, it is recommended to first disable charging, then disable charge termination and finally set this bit to 1. Setting this bit to 1 also disables the reverse boost prevention circuit and the BATOVP circuit. With a battery attached, setting this bit to 1 may be helpful to ensure full battery charging as explained in the reverse battery prevention circuit section. In the event of battery overvoltage (e.g., recovery from large SYS load transient requiring supplement), the BATOVP protection circuit turns off the buck converter to allow the battery to discharge through SYS.

## 9.6.3 Control Register (READ/WRITE)

Memory location: 02, Reset state: 1000 1100

BIT	NAME	Read/Write	FUNCTION
B7 (MSB)	RESET	Write only	Write: 1 – Reset all registers to default values 0 – No effect Read: always get “1”
B6	IUSB_LIMIT_2	Read/Write	000 – USB2.0 host with 100mA current limit
B5	IUSB_LIMIT_1	Read/Write	001 – USB3.0 host with 150mA current limit
B4	IUSB_LIMIT_0	Read/Write	010 – USB2.0 host with 500mA current limit 011 – USB host/charger with 800mA current limit 100 – USB3.0 host with 900mA current limit 101 – USB host/charger with 1500mA current limit 110–111 – NA (default 000 <sup>(1)</sup> )
B3	EN_STAT	Read/Write	1 – Enable STAT output to show charge status, 0-Disable STAT output for charge status. Fault interrupts are still show even when EN_STAT = 0. (default 1)
B2	TE	Read/Write	1 – Enable charge current termination, 0-Disable charge current termination (default 1)
B1	$\overline{CE}$	Read/Write	1 – Charging is disabled 0 – Charging enabled (default 0 bq24160/1/1B/3/8)
B0 (LSB)	HZ_MODE	Read/Write	1 – High impedance mode 0 – Not high impedance mode (default 0)

(1) When in DEFAULT mode, the D+/D– (bq24160) or PSEL (bq24161/8) inputs determine the input current limit for the USB input.

### RESET Bit

The RESET bit in the control register (0x02h) is used to reset all the charge parameters. Write “1” to RESET bit to reset all the registers to default values and place the bq2416xx into DEFAULT mode and turn off the watchdog timer. The RESET bit is automatically cleared to zero once the bq2416xx enters DEFAULT mode.

### $\overline{\text{CE}}$ Bit (Charge Enable)

The  $\overline{\text{CE}}$  bit in the control register (0x02h) is used to disable or enable the charge process. A low logic level (0) on this bit enables the charge and a high logic level (1) disables the charge. When charge is disabled, the SYS output regulates to VSYS(REG) and battery is disconnected from the SYS. Supplement mode is still available if the system load demands cannot be met by the supply.

### HZ\_MODE Bit (High Impedance Mode Enable)

The HZ\_MODE bit in the control register (0x02h) is used to disable or enable the high impedance mode. A low logic level (0) on this bit enables the IC and a high logic level (1) puts the IC in a low quiescent current state called high impedance mode. When in high impedance mode, the converter is off and the battery FET and BGATE are on. The load on SYS is supplied by the battery.

## 9.6.4 Control/Battery Voltage Register (READ/WRITE)

Memory location: 03, Reset state: 0001 0100

BIT	NAME	Read/Write	FUNCTION
B7 (MSB)	V <sub>BREG5</sub>	Read/Write	Battery Regulation Voltage: 640 mV (default 0)
B6	V <sub>BREG4</sub>	Read/Write	Battery Regulation Voltage: 320 mV (default 0)
B5	V <sub>BREG3</sub>	Read/Write	Battery Regulation Voltage: 160 mV (default 0)
B4	V <sub>BREG2</sub>	Read/Write	Battery Regulation Voltage: 80 mV (default 1)
B3	V <sub>BREG1</sub>	Read/Write	Battery Regulation Voltage: 40 mV (default 0)
B2	V <sub>BREG0</sub>	Read/Write	Battery Regulation Voltage: 20 mV (default 1)
B1	I <sub>NLIMIT</sub>	Read/Write	Input Limit for IN input- 0 – 1.5A 1 – 2.5A (default 0)
B0 (LSB)	D+/D- <sub>EN</sub>	Read/Write	0 – Normal state, D+/D- Detection done 1 – Force D+/D- Detection. Returns to “0” after detection is done. (default 0)

- Charge voltage range is 3.5V–4.44V with the offset of 3.5V and step of 20mV (default 3.6V).
- Before writing to increase VBATREG register following a BATOVP event (e.g., IN or USB voltage is applied, IC remains in DEFAULT mode and then VBAT>3.6V is attached), toggle the HiZ bit or CD pin to clear the BATOVP fault.

## 9.6.5 Vender/Part/Revision Register (READ only)

Memory location: 04, Reset state: 0100 0000

BIT	NAME	Read/Write	FUNCTION
B7 (MSB)	Vender2	Read only	Vender Code: bit 2 (default 0)
B6	Vender1	Read only	Vender Code: bit 1 (default 1)
B5	Vender0	Read only	Vender Code: bit 0 (default 0)
B4	PN1	Read only	For I <sup>2</sup> C Address 6Bh:
B3	PN0	Read only	00: bq2416xx 01–11: Future product spins

BIT	NAME	Read/Write	FUNCTION
B2	Revision2	Read only	000: Revision 1.0 001: Revision 1.1 010: Revision 2.0 011: Revision 2.1 100: Revision 2.2 101: Revision 2.3 110-111: Future Revisions
B1	Revision1	Read only	
B0 (LSB)	Revision0	Read only	

### 9.6.6 Battery Termination/Fast Charge Current Register (READ/WRITE)

Memory location: 05, Reset state: 0011 0010

BIT	NAME	Read/Write	FUNCTION
B7 (MSB)	I <sub>CHRG4</sub>	Read/Write	Charge current: 1200mA – (default 0)
B6	I <sub>CHRG3</sub>	Read/Write	Charge current: 600mA – (default 0)
B5	I <sub>CHRG2</sub>	Read/Write	Charge current: 300mA – (default 1)
B4	I <sub>CHRG1</sub>	Read/Write	Charge current: 150mA – (default 1)
B3	I <sub>CHRG0</sub>	Read/Write	Charge current: 75 mA (default 0)
B2	I <sub>TERM2</sub>	Read/Write	Termination current sense voltage: 200mA (default 0)
B1	I <sub>TERM1</sub>	Read/Write	Termination current sense voltage: 100mA (default 1)
B0 (LSB)	I <sub>TERM0</sub>	Read/Write	Termination current sense voltage: 50mA (default 0)

- Charge current sense offset is 550mA and default charge current is 1000mA.
- Termination threshold offset is 50mA and default termination current is 150mA

### 9.6.7 V<sub>IN-DPM</sub> Voltage/ DPPM Status Register

Memory location: 06, Reset state: xx00 0000

BIT	NAME	Read/Write	FUNCTION
B7(MSB)	MINSYS_STATUS	Read Only	1 – Minimum System Voltage mode is active ( $V_{BAT} < V_{MINSYS}$ ) 0 – Minimum System Voltage mode is not active
B6	DPM_STATUS	Read Only	1 – V <sub>IN-DPM</sub> mode is active 0 – V <sub>IN-DPM</sub> mode is not active
B5	V <sub>INDPM2(USB)</sub>	Read/Write	USB input V <sub>IN-DPM</sub> voltage: 320mV (default 0)
B4	V <sub>INDPM1(USB)</sub>	Read/Write	USB input V <sub>IN-DPM</sub> voltage: 160mV (default 0)
B3	V <sub>INDPM0(USB)</sub>	Read/Write	USB input V <sub>IN-DPM</sub> voltage: 80mV (default 0)
B2	V <sub>INDPM2(IN)</sub>	Read/Write	IN input V <sub>IN-DPM</sub> voltage: 320mV (default 0)
B1	V <sub>INDPM1(IN)</sub>	Read/Write	IN input V <sub>IN-DPM</sub> voltage: 160mV (default 0)
B0(LSB)	V <sub>INDPM0(IN)</sub>	Read/Write	IN input V <sub>IN-DPM</sub> voltage: 80mV (default 0)

- V<sub>IN-DPM</sub> voltage offset is 4.20V and default V<sub>IN-DPM</sub> threshold is 4.20V.

### 9.6.8 Safety Timer/ NTC Monitor Register (READ/WRITE)

Memory location: 07, Reset state: 1001 1xxx

BIT	NAME	Read/Write	FUNCTION
B7 (MSB)	2XTMR_EN	Read/Write	1 – Timer slowed by 2x when in thermal regulation, input current limit, V <sub>IN-DPM</sub> or DPPM 0 – Timer not slowed at any time (default 0) (bq24160/1 only)
B6	TMR_1	Read/Write	Safety Timer Time Limit – 00 – 27 minute fast charge 01 – 6 hour fast charge 10 – 9 hour fast charge 11 – Disable safety timers (default 00) (bq24160/1 only)
B5	TMR_2	Read/Write	
B4	NA	Read/Write	NA

BIT	NAME	Read/Write	FUNCTION
B3	TS_EN	Read/Write	0 – TS function disabled 1 – TS function enabled (default 1)
B2	TS_FAULT1	Read only	TS Fault Mode: 00 – Normal, No TS fault 01 – TS temp < T <sub>COLD</sub> or TS temp > T <sub>HOT</sub> (Charging suspended) 10 – T <sub>COOL</sub> > TS temp > T <sub>COLD</sub> (Charge current reduced by half, bq24160 only) 11 – T <sub>WARM</sub> < TS temp < T <sub>HOT</sub> (Charge voltage reduced by 140mV, bq24160 only)
B1	TS_FAULT0	Read only	
B0 (LSB)	LOW_CHG	Read/ Write	0 – Charge current as programmed in Register 0x05 1 – Charge current is half programmed value in Register 0x05 (default 0)

### 2xTMR\_EN Bit (2x Timer Enable)

The 2xTMR\_EN bit is used to slow down the timer when charge current is reduced by the system load. When 2xTMR\_EN is a "1", the safety timer is slowed to half speed effectively doubling the timer time. The conditions that activate the 2x timer are: Input Current Limit, V<sub>INDPM</sub>, Thermal Regulation, LOW\_CHG, BATSHRT and TS Cool. When 2xTMR\_EN is a "0", the timer operates at normal speed in all conditions.

### LOW\_CHG Bit (Low Charge Mode Enable)

The LOW\_CHG bit is used to reduce the charge current from the programmed value. This feature is used by systems where battery NTC is monitored by the host and requires a reduced charge current setting or by systems that need a "preconditioning" current for low battery voltages. Write a "1" to this bit to charge at half of the programmed charge current (bq24160/1/3/8). Write a "0" to this bit to charge at the programmed charge current.

## 10 Application and Implementation

### 10.1 Application Information

A typical application circuit using the bq24160 with a smartphone's GSM power amplifier (PA) powered directly from the battery is shown in Figure 21. A typical application circuit using the bq24161 with a smartphone's GSM PA powered from the SYS rail, to allow for calls even with a deeply discharged battery, is shown in Figure 22. Each circuit shows the minimum capacitance requirements for each pin and typical recommended inductance value of 1.5  $\mu$ H. The TS resistor divider for configuring the TS function for the battery's specific thermistor can be computed from equations Equation 1 and Equation 2. The resistor on STAT is sized per the LED current requirements. All other configuration settings for VINDPM, input current limit, charge current and charge voltage are made in EEPROM registers using I2C commands. Options for sizing the inductor outside the 1.5  $\mu$ H recommended value and additional SYS pin capacitance are explained in the next section.

### 10.2 Typical Application

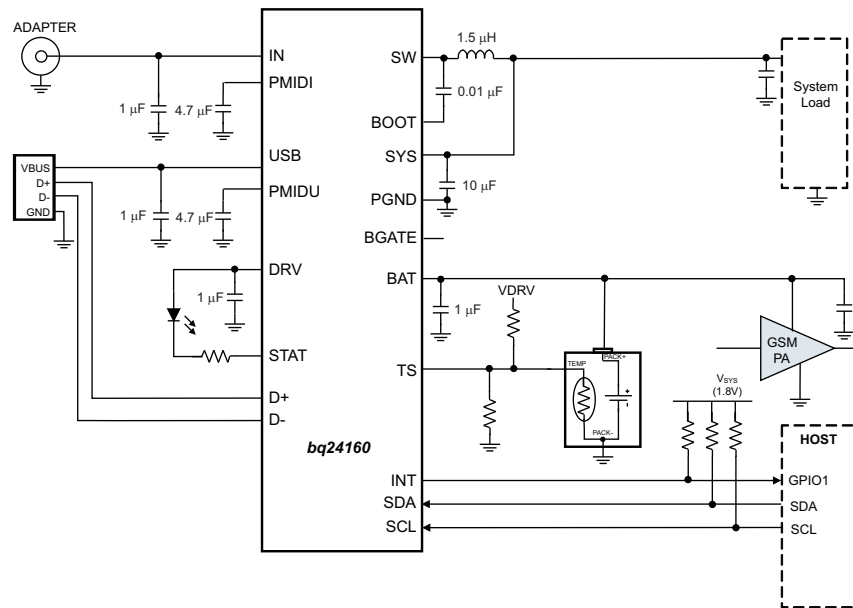

Figure 21. bq24160, Shown with no External Discharge FET, PA Connected to Battery

Typical Application (continued)

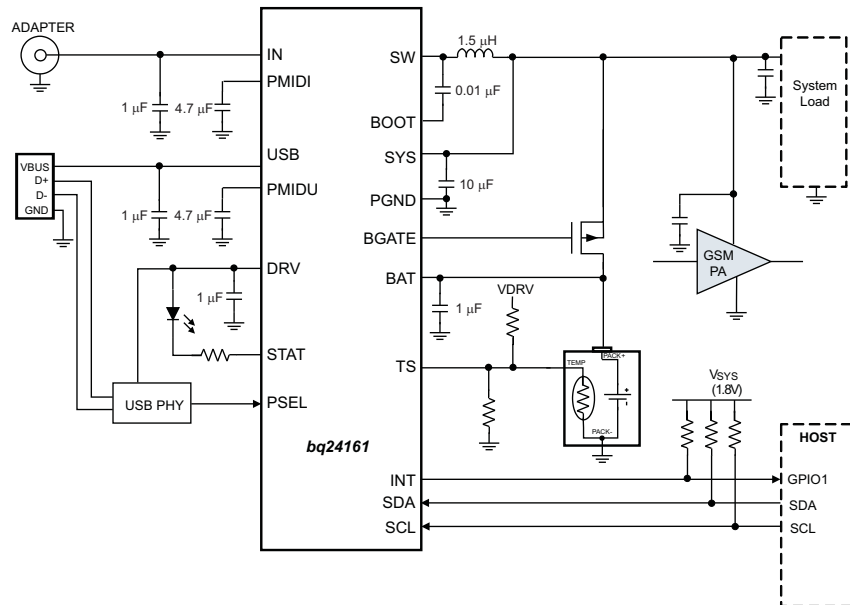

Figure 22. bq24161, Shown with External Discharge FET, PA Connected to System for GSM Call Support with a Deeply Discharged or No Battery

10.2.1 Design Requirements

		Min	Typ	Max	Unit
Supply voltage, $V_{IN}$	Input voltage from ac adapter	4.2		10	V
USB voltage, $V_{USB}$	Input voltage from USB or equivalent supply	4.2		6	V
System voltage, $V_{SYS}$	Voltage output at SYS terminal (depends on VBAT voltage and status of $V_{INDPM}$ )	3.3		$V_{BATRE} + 4.17\%$	V
Battery voltage, $V_{BAT}$	Voltage output at VBAT terminal (registers set via I2C communication)	2	4.2	4.44	V
Supply current, $I_{IN(MAX)}$	Maximum input current from ac adapter input (registers set via I2C communication)	1.5		2.5	A
Supply current, $I_{USB(MAX)}$	Maximum input current from USB input (registers set via I2C communication)	0.1	0.5	1.5	A
Fast charge current, $I_{CHRG(MAX)}$	Battery charge current (registers set via I2C communication)	0.550		2.5	A
Operating junction temperature range, $T_J$		-40		125	°C

10.2.2 Detailed Design Procedure

10.2.2.1 Output Inductor and Capacitor Selection Guidelines

When selecting an inductor, several attributes must be examined to find the right part for the application. First, the inductance value should be selected. The bq2416xx is designed to work with 1.5µH to 2.2µH inductors. The chosen value will have an effect on efficiency and package size. Due to the smaller current ripple, some efficiency gain is reached using the 2.2µH inductor, however, due to the physical size of the inductor, this may not be a viable option. The 1.5µH inductor provides a good tradeoff between size and efficiency.

Once the inductance has been selected, the peak current must be calculated in order to choose the current rating of the inductor. Use Equation 5 to calculate the peak current.

$$I_{PEAK} = I_{LOAD(MAX)} \times \left( 1 + \frac{\%RIPPLE}{2} \right) \tag{5}$$

The inductor selected must have a saturation current rating greater than or equal to the calculated  $I_{PEAK}$ . Due to the high currents possible with the bq2416xx, a thermal analysis must also be done for the inductor. Many inductors have a 40°C temperature-rise rating. The DC component of the current can cause a 40°C temperature rise above the ambient temperature in the inductor. For this analysis, the typical load current may be used adjusted for the duty cycle of the load transients. For example, if the application requires a 1.5A DC load with peaks at 2.5A 20% of the time, a  $\Delta 40^\circ\text{C}$  temperature rise current must be greater than 1.7A:

$$I_{TEMPRISE} = I_{LOAD} + D \times (I_{PEAK} - I_{LOAD}) = 1.5\text{A} + 0.2 \times (2.5\text{A} - 1.5\text{A}) = 1.7\text{A} \quad (6)$$

The bq2416xx provides internal loop compensation. Using this scheme, the bq2416xx is stable with 10 $\mu\text{F}$  to 200 $\mu\text{F}$  of local capacitance on the SYS output. The capacitance on the SYS rail can be higher if distributed amongst the rail. To reduce the output voltage ripple, a ceramic capacitor with the capacitance between 10 $\mu\text{F}$  and 47 $\mu\text{F}$  is recommended for local bypass to SYS. A 47 $\mu\text{F}$  bypass capacitor is recommended for optimal transient response.

### 10.2.3 Application Curves

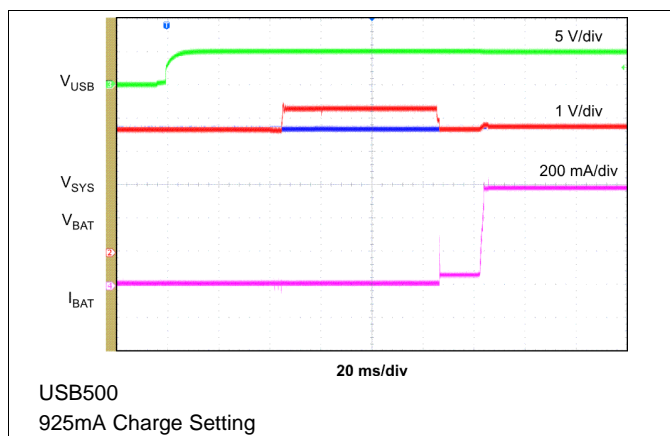

**Figure 23. USB Plug-In with Battery Connected**

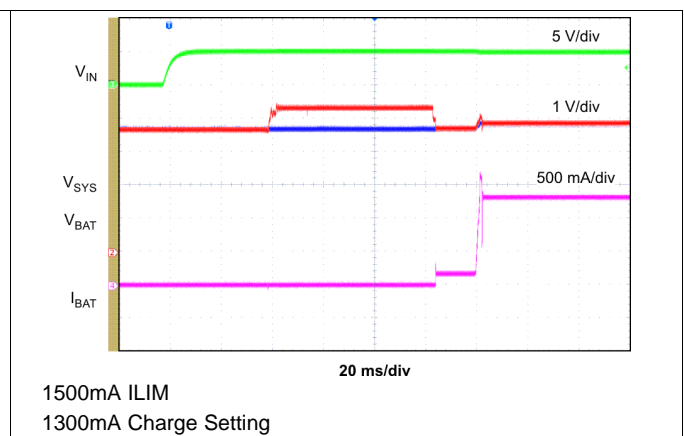

**Figure 24. IN Plug-in with Battery Connected**

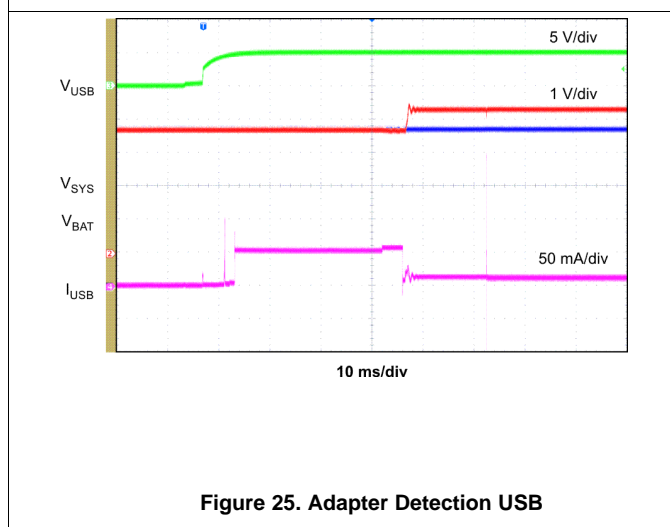

**Figure 25. Adapter Detection USB**

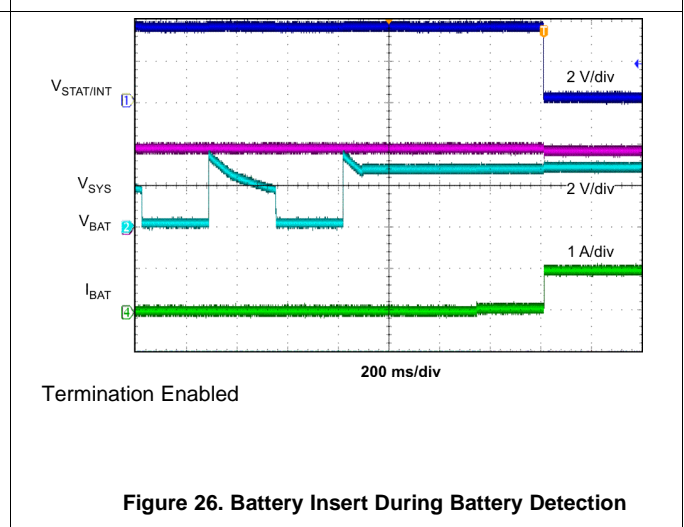

**Figure 26. Battery Insert During Battery Detection**

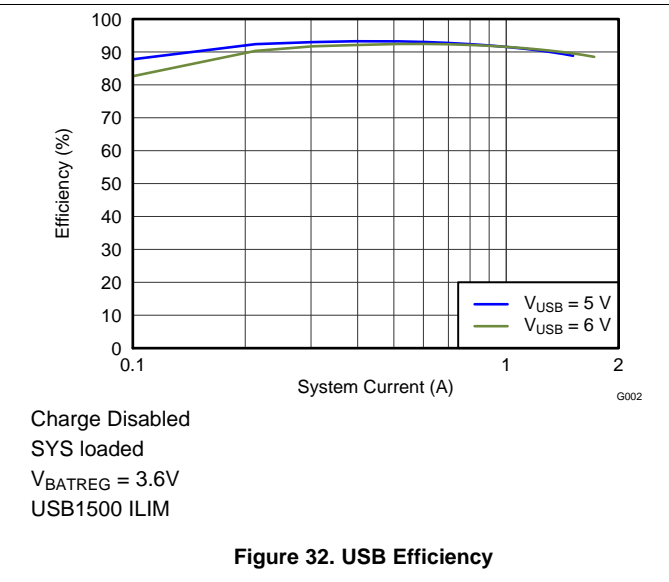
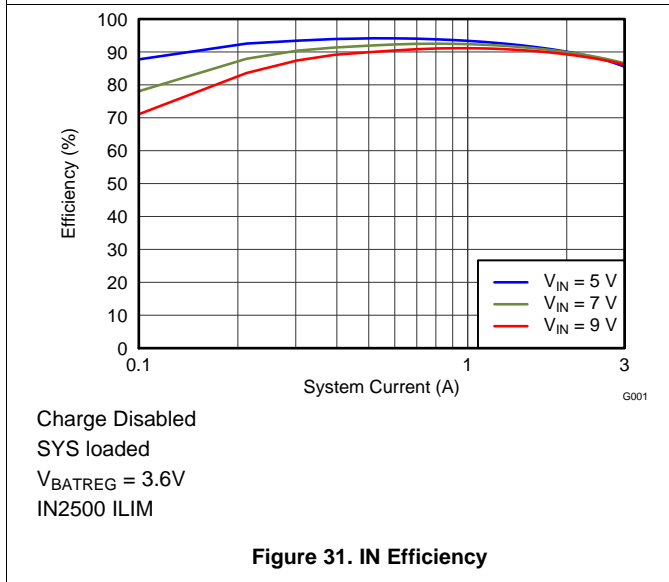
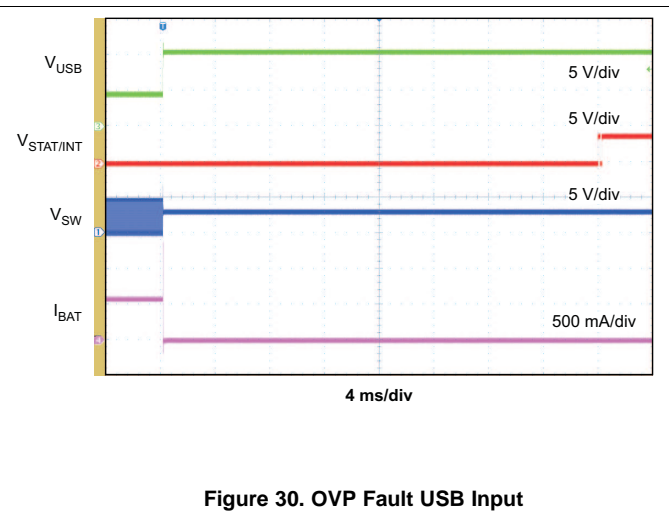
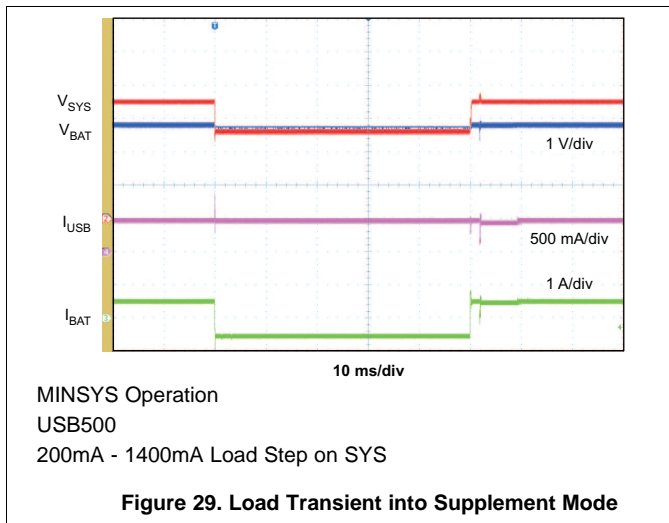
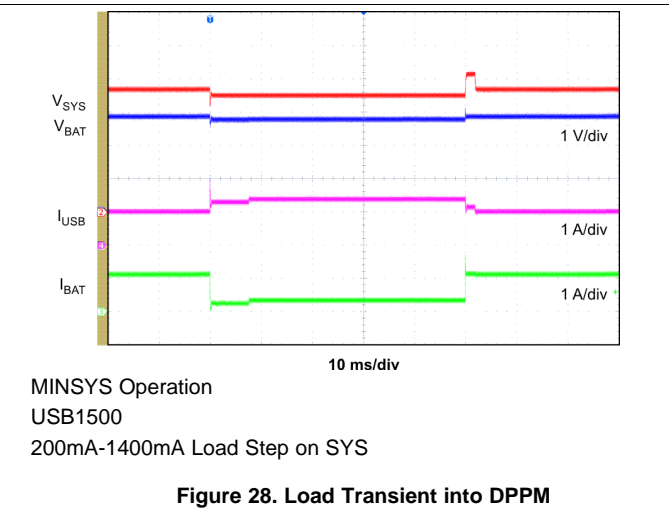
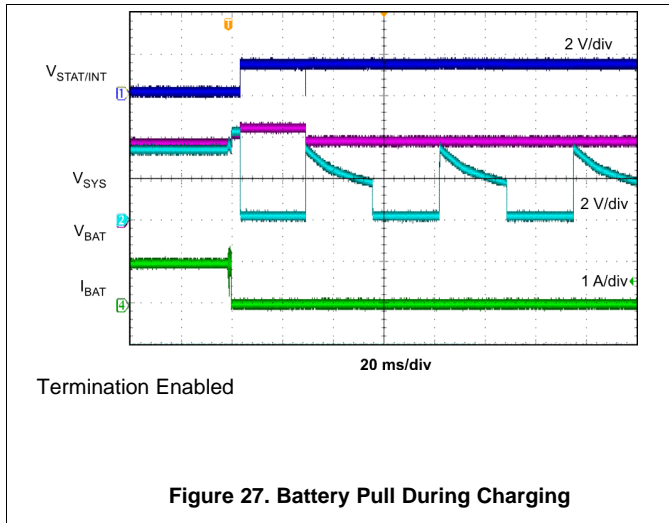

## 11 Power Supply Recommendations

### 11.1 Requirements for SYS Output

In order to provide an output voltage on SYS, the bq2416xx requires either a power supply between 4.2 V and 6.0 V for USB input on all versions, 4.2 V and 6.0 V for IN input on bq24168 and 4.2 V and 10.0 V on the remaining versions with at least 100 mA current rating connected to IN or USB OR a single-cell Lilon battery with voltage  $> V_{BATUVLO}$  connected to BAT. The source current rating needs to be at least 2.5 A in order for the charger's buck converter to provide maximum output power to SYS.

### 11.2 Requirements for Charging

In order for charging to occur, the source voltage as measured at the IC's USB or IN pins (factoring in cable/trace losses from the source) must be greater than the  $V_{INDPM}$  threshold (but less than the maximum values above) and the source's current rating must be higher than the buck converter needs to provide the load on SYS. For charging at a desired charge current of  $I_{CHRG}$ ,  $V_{USBorIN} \times I_{USBorIN} \times \eta > V_{SYS} \times (I_{SYS} + I_{CHRG})$  where  $\eta$  is the efficiency estimate from [Figure 1](#) or [Figure 2](#) and  $V_{SYS} = V_{BAT}$  when  $V_{BAT}$  charges above  $V_{MINSYS}$ . The charger limits  $I_{USBorIN}$  to that input's current limit setting. With  $I_{SYS} = 0$  A, the charger consumes maximum power at the end of CC mode, when the voltage at the BAT pin is near  $V_{BATREG}$  but  $I_{CHRG}$  has not started to taper off toward  $I_{TERM}$ .

## 12 Layout

### 12.1 Layout Guidelines

It is important to pay special attention to the PCB layout. [Figure 33](#) provides a sample layout for the high current paths of the bq2416xx. A list of layout guidelines follows.

- To obtain optimal performance, the power input capacitors, connected from the PMID input to PGND, must be placed as close as possible to the bq2416xx
- Minimize the amount of inductance between BAT and the positive connection of the battery terminal. If a large parasitic board inductance on BAT is expected, increase the bypass capacitance on BAT.
- Place 4.7 $\mu$ F input capacitor as close to PMID\_ pin and PGND pin as possible to make high frequency current loop area as small as possible. Place 1 $\mu$ F input capacitor GNDs as close to the respective PMID cap GND and PGND pins as possible to minimize the ground difference between the input and PMID\_.
- The traces from the input connector to the inputs of the bq2416xx should be as wide as possible to minimize the impedance in the line. Although the VINDPM feature will allow operation from input sources having high resistances(impedances), the bq2416xx input pins (IN and USB) have been optimized to connect to input sources with no more than 350mohm of input resistance, including cables and PCB traces
- The local bypass capacitor from SYS to GND should be connected between the SYS pin and PGND of the IC. The intent is to minimize the current path loop area from the SW pin through the LC filter and back to the PGND pin.
- Place all decoupling capacitors close to their respective IC pins and as close as to PGND (do not place components such that routing interrupts power stage currents). All small control signals should be routed away from the high-current paths.
- The PCB should have a ground plane (return) connected directly to the return of all components through vias (two vias per capacitor for power-stage capacitors, one via per capacitor for small-signal components). It is also recommended to put vias inside the PGND pads for the IC, if possible. A star ground design approach is typically used to keep circuit block currents isolated (high-power/low-power small-signal) which reduces noise-coupling and ground-bounce issues. A single ground plane for this design gives good results. With this small layout and a single ground plane, there is no ground-bounce issue, and having the components segregated minimizes coupling between signals.
- The high-current charge paths into IN, USB, BAT, SYS and from the SW pins must be sized appropriately for the maximum charge current in order to avoid voltage drops in these traces. The PGND pins should be connected to the ground plane to return current through the internal low-side FET.
- For high-current applications, the balls for the power paths should be connected to as much copper in the board as possible. This allows better thermal performance because the board conducts heat away from the IC.

## 12.2 Layout Example

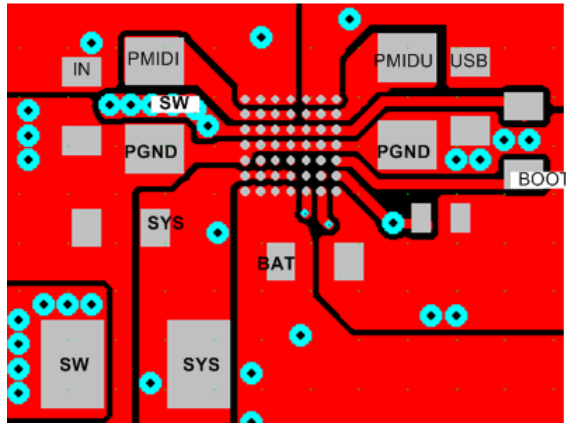

WCSP

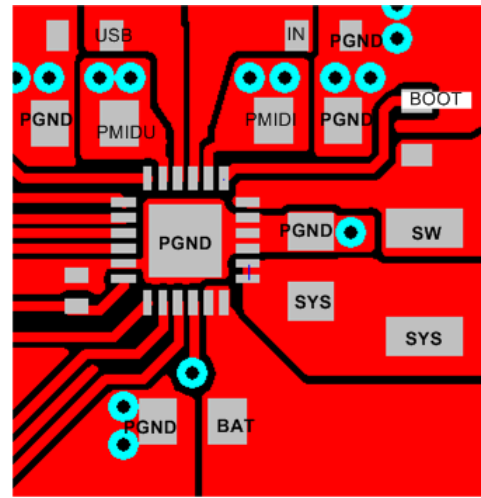

VQFN

Figure 33. Recommended bq2416xx PCB Layout

## 13 Device and Documentation Support

### 13.1 Related Links

The table below lists quick access links. Categories include technical documents, support and community resources, tools and software, and quick access to sample or buy.

**Table 2. Related Links**

PARTS	PRODUCT FOLDER	SAMPLE & BUY	TECHNICAL DOCUMENTS	TOOLS & SOFTWARE	SUPPORT & COMMUNITY
bq24160	<a href="#">Click here</a>	<a href="#">Click here</a>	<a href="#">Click here</a>	<a href="#">Click here</a>	<a href="#">Click here</a>
bq24160A	<a href="#">Click here</a>	<a href="#">Click here</a>	<a href="#">Click here</a>	<a href="#">Click here</a>	<a href="#">Click here</a>
bq24161	<a href="#">Click here</a>	<a href="#">Click here</a>	<a href="#">Click here</a>	<a href="#">Click here</a>	<a href="#">Click here</a>
bq24161B	<a href="#">Click here</a>	<a href="#">Click here</a>	<a href="#">Click here</a>	<a href="#">Click here</a>	<a href="#">Click here</a>
bq24163	<a href="#">Click here</a>	<a href="#">Click here</a>	<a href="#">Click here</a>	<a href="#">Click here</a>	<a href="#">Click here</a>
bq24168	<a href="#">Click here</a>	<a href="#">Click here</a>	<a href="#">Click here</a>	<a href="#">Click here</a>	<a href="#">Click here</a>

### 13.2 Community Resources

The following links connect to TI community resources. Linked contents are provided "AS IS" by the respective contributors. They do not constitute TI specifications and do not necessarily reflect TI's views; see TI's [Terms of Use](#).

**TI E2E™ Online Community** *TI's Engineer-to-Engineer (E2E) Community*. Created to foster collaboration among engineers. At [e2e.ti.com](http://e2e.ti.com), you can ask questions, share knowledge, explore ideas and help solve problems with fellow engineers.

**Design Support** *TI's Design Support* Quickly find helpful E2E forums along with design support tools and contact information for technical support.

### 13.3 Trademarks

E2E is a trademark of Texas Instruments.  
All other trademarks are the property of their respective owners.

### 13.4 Electrostatic Discharge Caution



These devices have limited built-in ESD protection. The leads should be shorted together or the device placed in conductive foam during storage or handling to prevent electrostatic damage to the MOS gates.

### 13.5 Glossary

[SLYZ022](#) — *TI Glossary*.

This glossary lists and explains terms, acronyms, and definitions.

## 14 Mechanical, Packaging, and Orderable Information

The following pages include mechanical packaging and orderable information. This information is the most current data available for the designated devices. This data is subject to change without notice and revision of this document. For browser-based versions of this data sheet, refer to the left-hand navigation.

**PACKAGING INFORMATION**

Orderable Device	Status (1)	Package Type	Package Drawing	Pins	Package Qty	Eco Plan (2)	Lead/Ball Finish (6)	MSL Peak Temp (3)	Op Temp (°C)	Device Marking (4/5)	Samples
BQ24160ARGER	ACTIVE	VQFN	RGE	24	3000	Green (RoHS & no Sb/Br)	CU NIPDAU	Level-2-260C-1 YEAR		BQ 24160A	<a href="#">Samples</a>
BQ24160ARGET	ACTIVE	VQFN	RGE	24	250	Green (RoHS & no Sb/Br)	CU NIPDAU	Level-2-260C-1 YEAR		BQ 24160A	<a href="#">Samples</a>
BQ24160RGER	ACTIVE	VQFN	RGE	24	3000	Green (RoHS & no Sb/Br)	CU NIPDAU	Level-2-260C-1 YEAR	-40 to 85	BQ 24160	<a href="#">Samples</a>
BQ24160RGET	ACTIVE	VQFN	RGE	24	250	Green (RoHS & no Sb/Br)	CU NIPDAU	Level-2-260C-1 YEAR	-40 to 85	BQ 24160	<a href="#">Samples</a>
BQ24160YFFR	ACTIVE	DSBGA	YFF	49	3000	Green (RoHS & no Sb/Br)	SNAGCU	Level-1-260C-UNLIM	-40 to 85	BQ24160	<a href="#">Samples</a>
BQ24160YFFT	ACTIVE	DSBGA	YFF	49	250	Green (RoHS & no Sb/Br)	SNAGCU	Level-1-260C-UNLIM	-40 to 85	BQ24160	<a href="#">Samples</a>
BQ24161BRGER	ACTIVE	VQFN	RGE	24	3000	Green (RoHS & no Sb/Br)	CU NIPDAU	Level-2-260C-1 YEAR	-40 to 85	BQ 24161B	<a href="#">Samples</a>
BQ24161BRGET	ACTIVE	VQFN	RGE	24	250	Green (RoHS & no Sb/Br)	CU NIPDAU	Level-2-260C-1 YEAR	-40 to 85	BQ 24161B	<a href="#">Samples</a>
BQ24161RGER	ACTIVE	VQFN	RGE	24	3000	Green (RoHS & no Sb/Br)	CU NIPDAU	Level-2-260C-1 YEAR	-40 to 85	BQ 24161	<a href="#">Samples</a>
BQ24161RGET	ACTIVE	VQFN	RGE	24	250	Green (RoHS & no Sb/Br)	CU NIPDAU	Level-2-260C-1 YEAR	-40 to 85	BQ 24161	<a href="#">Samples</a>
BQ24161YFFR	ACTIVE	DSBGA	YFF	49	3000	Green (RoHS & no Sb/Br)	SNAGCU	Level-1-260C-UNLIM	-40 to 85	BQ24161	<a href="#">Samples</a>
BQ24161YFFT	ACTIVE	DSBGA	YFF	49	250	Green (RoHS & no Sb/Br)	SNAGCU	Level-1-260C-UNLIM	-40 to 85	BQ24161	<a href="#">Samples</a>
BQ24163RGER	ACTIVE	VQFN	RGE	24	3000	Green (RoHS & no Sb/Br)	CU NIPDAU	Level-2-260C-1 YEAR	-40 to 85	BQ 24163	<a href="#">Samples</a>
BQ24163RGET	ACTIVE	VQFN	RGE	24	250	Green (RoHS & no Sb/Br)	CU NIPDAU	Level-2-260C-1 YEAR	-40 to 85	BQ 24163	<a href="#">Samples</a>
BQ24163YFFR	ACTIVE	DSBGA	YFF	49	3000	Green (RoHS & no Sb/Br)	SNAGCU	Level-1-260C-UNLIM	-40 to 85	BQ24163	<a href="#">Samples</a>
BQ24163YFFT	ACTIVE	DSBGA	YFF	49	250	Green (RoHS & no Sb/Br)	SNAGCU	Level-1-260C-UNLIM	-40 to 85	BQ24163	<a href="#">Samples</a>
BQ24168RGER	ACTIVE	VQFN	RGE	24	3000	Green (RoHS & no Sb/Br)	CU NIPDAU	Level-2-260C-1 YEAR	-40 to 85	BQ 24168	<a href="#">Samples</a>

Orderable Device	Status (1)	Package Type	Package Drawing	Pins	Package Qty	Eco Plan (2)	Lead/Ball Finish (6)	MSL Peak Temp (3)	Op Temp (°C)	Device Marking (4/5)	Samples
BQ24168RGET	ACTIVE	VQFN	RGE	24	250	Green (RoHS & no Sb/Br)	CU NIPDAU	Level-2-260C-1 YEAR	-40 to 85	BQ 24168	<a href="#">Samples</a>
BQ24168YFFR	ACTIVE	DSBGA	YFF	49	3000	Green (RoHS & no Sb/Br)	SNAGCU	Level-1-260C-UNLIM	-40 to 85	BQ24168	<a href="#">Samples</a>
BQ24168YFFT	ACTIVE	DSBGA	YFF	49	250	Green (RoHS & no Sb/Br)	SNAGCU	Level-1-260C-UNLIM	-40 to 85	BQ24168	<a href="#">Samples</a>

(1) The marketing status values are defined as follows:

**ACTIVE:** Product device recommended for new designs.

**LIFEBUY:** TI has announced that the device will be discontinued, and a lifetime-buy period is in effect.

**NRND:** Not recommended for new designs. Device is in production to support existing customers, but TI does not recommend using this part in a new design.

**PREVIEW:** Device has been announced but is not in production. Samples may or may not be available.

**OBSOLETE:** TI has discontinued the production of the device.

(2) Eco Plan - The planned eco-friendly classification: Pb-Free (RoHS), Pb-Free (RoHS Exempt), or Green (RoHS & no Sb/Br) - please check <http://www.ti.com/productcontent> for the latest availability information and additional product content details.

**TBD:** The Pb-Free/Green conversion plan has not been defined.

**Pb-Free (RoHS):** TI's terms "Lead-Free" or "Pb-Free" mean semiconductor products that are compatible with the current RoHS requirements for all 6 substances, including the requirement that lead not exceed 0.1% by weight in homogeneous materials. Where designed to be soldered at high temperatures, TI Pb-Free products are suitable for use in specified lead-free processes.

**Pb-Free (RoHS Exempt):** This component has a RoHS exemption for either 1) lead-based flip-chip solder bumps used between the die and package, or 2) lead-based die adhesive used between the die and leadframe. The component is otherwise considered Pb-Free (RoHS compatible) as defined above.

**Green (RoHS & no Sb/Br):** TI defines "Green" to mean Pb-Free (RoHS compatible), and free of Bromine (Br) and Antimony (Sb) based flame retardants (Br or Sb do not exceed 0.1% by weight in homogeneous material)

(3) MSL, Peak Temp. - The Moisture Sensitivity Level rating according to the JEDEC industry standard classifications, and peak solder temperature.

(4) There may be additional marking, which relates to the logo, the lot trace code information, or the environmental category on the device.

(5) Multiple Device Markings will be inside parentheses. Only one Device Marking contained in parentheses and separated by a "~" will appear on a device. If a line is indented then it is a continuation of the previous line and the two combined represent the entire Device Marking for that device.

(6) Lead/Ball Finish - Orderable Devices may have multiple material finish options. Finish options are separated by a vertical ruled line. Lead/Ball Finish values may wrap to two lines if the finish value exceeds the maximum column width.

**Important Information and Disclaimer:** The information provided on this page represents TI's knowledge and belief as of the date that it is provided. TI bases its knowledge and belief on information provided by third parties, and makes no representation or warranty as to the accuracy of such information. Efforts are underway to better integrate information from third parties. TI has taken and continues to take reasonable steps to provide representative and accurate information but may not have conducted destructive testing or chemical analysis on incoming materials and chemicals. TI and TI suppliers consider certain information to be proprietary, and thus CAS numbers and other limited information may not be available for release.

In no event shall TI's liability arising out of such information exceed the total purchase price of the TI part(s) at issue in this document sold by TI to Customer on an annual basis.

## TAPE AND REEL INFORMATION

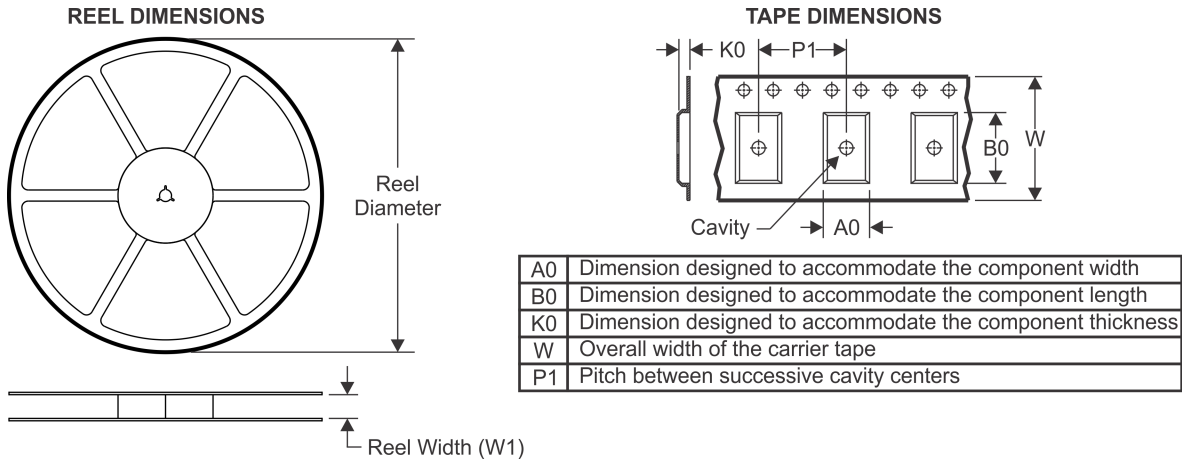

### QUADRANT ASSIGNMENTS FOR PIN 1 ORIENTATION IN TAPE



\*All dimensions are nominal

Device	Package Type	Package Drawing	Pins	SPQ	Reel Diameter (mm)	Reel Width W1 (mm)	A0 (mm)	B0 (mm)	K0 (mm)	P1 (mm)	W (mm)	Pin1 Quadrant
BQ24160ARGER	VQFN	RGE	24	3000	330.0	12.4	4.25	4.25	1.15	8.0	12.0	Q2
BQ24160ARGET	VQFN	RGE	24	250	180.0	12.4	4.25	4.25	1.15	8.0	12.0	Q2
BQ24160RGER	VQFN	RGE	24	3000	330.0	12.4	4.25	4.25	1.15	8.0	12.0	Q2
BQ24160RGET	VQFN	RGE	24	250	180.0	12.4	4.25	4.25	1.15	8.0	12.0	Q2
BQ24160YFFR	DSBGA	YFF	49	3000	180.0	8.4	2.93	2.93	0.81	4.0	8.0	Q1
BQ24160YFFT	DSBGA	YFF	49	250	180.0	8.4	2.93	2.93	0.81	4.0	8.0	Q1
BQ24161BRGER	VQFN	RGE	24	3000	330.0	12.4	4.25	4.25	1.15	8.0	12.0	Q2
BQ24161BRGET	VQFN	RGE	24	250	180.0	12.4	4.25	4.25	1.15	8.0	12.0	Q2
BQ24161RGER	VQFN	RGE	24	3000	330.0	12.4	4.25	4.25	1.15	8.0	12.0	Q2
BQ24161RGET	VQFN	RGE	24	250	180.0	12.4	4.25	4.25	1.15	8.0	12.0	Q2
BQ24161YFFR	DSBGA	YFF	49	3000	180.0	8.4	2.93	2.93	0.81	4.0	8.0	Q1
BQ24161YFFT	DSBGA	YFF	49	250	180.0	8.4	2.93	2.93	0.81	4.0	8.0	Q1
BQ24163RGER	VQFN	RGE	24	3000	330.0	12.4	4.25	4.25	1.15	8.0	12.0	Q2
BQ24163RGET	VQFN	RGE	24	250	180.0	12.4	4.25	4.25	1.15	8.0	12.0	Q2
BQ24163YFFR	DSBGA	YFF	49	3000	180.0	8.4	2.93	2.93	0.81	4.0	8.0	Q1
BQ24163YFFT	DSBGA	YFF	49	250	180.0	8.4	2.93	2.93	0.81	4.0	8.0	Q1
BQ24168RGER	VQFN	RGE	24	3000	330.0	12.4	4.25	4.25	1.15	8.0	12.0	Q2
BQ24168RGET	VQFN	RGE	24	250	180.0	12.4	4.25	4.25	1.15	8.0	12.0	Q2

Device	Package Type	Package Drawing	Pins	SPQ	Reel Diameter (mm)	Reel Width W1 (mm)	A0 (mm)	B0 (mm)	K0 (mm)	P1 (mm)	W (mm)	Pin1 Quadrant
BQ24168YFFR	DSBGA	YFF	49	3000	180.0	8.4	2.93	2.93	0.81	4.0	8.0	Q1
BQ24168YFFT	DSBGA	YFF	49	250	180.0	8.4	2.93	2.93	0.81	4.0	8.0	Q1

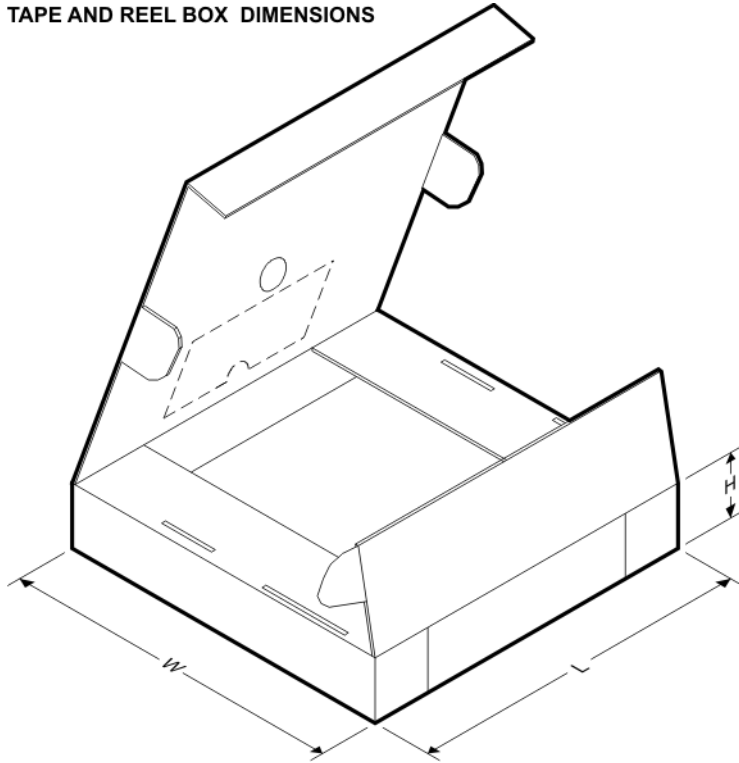
**TAPE AND REEL BOX DIMENSIONS**

\*All dimensions are nominal

Device	Package Type	Package Drawing	Pins	SPQ	Length (mm)	Width (mm)	Height (mm)
BQ24160ARGER	VQFN	RGE	24	3000	367.0	367.0	35.0
BQ24160ARGET	VQFN	RGE	24	250	210.0	185.0	35.0
BQ24160RGER	VQFN	RGE	24	3000	367.0	367.0	35.0
BQ24160RGET	VQFN	RGE	24	250	210.0	185.0	35.0
BQ24160YFFR	DSBGA	YFF	49	3000	182.0	182.0	20.0
BQ24160YFFT	DSBGA	YFF	49	250	182.0	182.0	20.0
BQ24161BRGER	VQFN	RGE	24	3000	367.0	367.0	35.0
BQ24161BRGET	VQFN	RGE	24	250	210.0	185.0	35.0
BQ24161RGER	VQFN	RGE	24	3000	367.0	367.0	35.0
BQ24161RGET	VQFN	RGE	24	250	210.0	185.0	35.0
BQ24161YFFR	DSBGA	YFF	49	3000	182.0	182.0	20.0
BQ24161YFFT	DSBGA	YFF	49	250	182.0	182.0	20.0
BQ24163RGER	VQFN	RGE	24	3000	367.0	367.0	35.0
BQ24163RGET	VQFN	RGE	24	250	210.0	185.0	35.0
BQ24163YFFR	DSBGA	YFF	49	3000	182.0	182.0	20.0

---

Device	Package Type	Package Drawing	Pins	SPQ	Length (mm)	Width (mm)	Height (mm)
BQ24163YFFT	DSBGA	YFF	49	250	182.0	182.0	20.0
BQ24168RGER	VQFN	RGE	24	3000	367.0	367.0	35.0
BQ24168RGET	VQFN	RGE	24	250	210.0	185.0	35.0
BQ24168YFFR	DSBGA	YFF	49	3000	182.0	182.0	20.0
BQ24168YFFT	DSBGA	YFF	49	250	182.0	182.0	20.0

# MECHANICAL DATA

YFF (R-XBGA-N49)

DIE-SIZE BALL GRID ARRAY

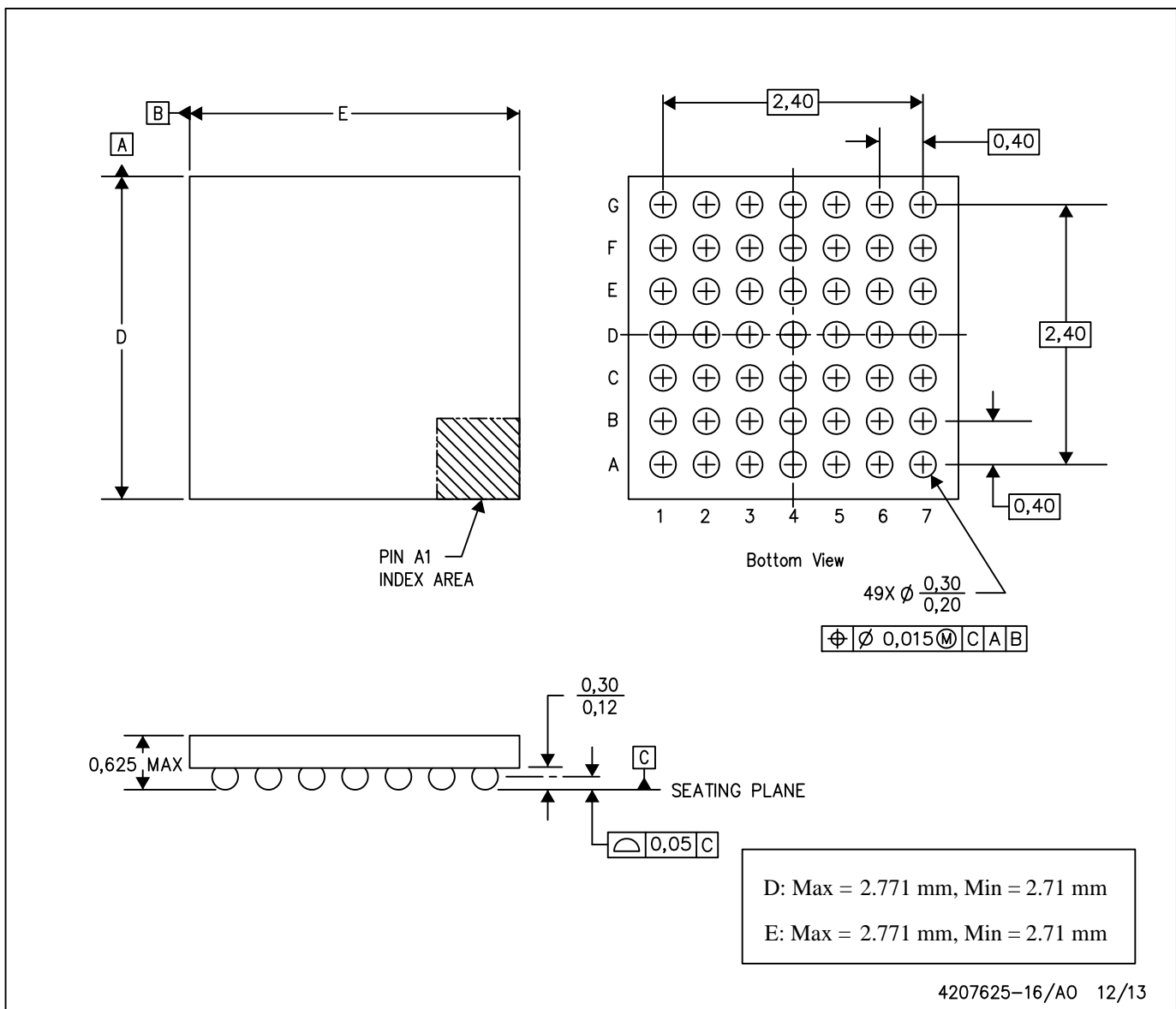

- NOTES: A. All linear dimensions are in millimeters. Dimensioning and tolerancing per ASME Y14.5M-1994.  
 B. This drawing is subject to change without notice.  
 C. NanoFree™ package configuration.

NanoFree is a trademark of Texas Instruments.

**RGE 24**

**GENERIC PACKAGE VIEW**

**VQFN - 1 mm max height**

PLASTIC QUAD FLATPACK - NO LEAD



Images above are just a representation of the package family, actual package may vary.  
Refer to the product data sheet for package details.

4204104/H

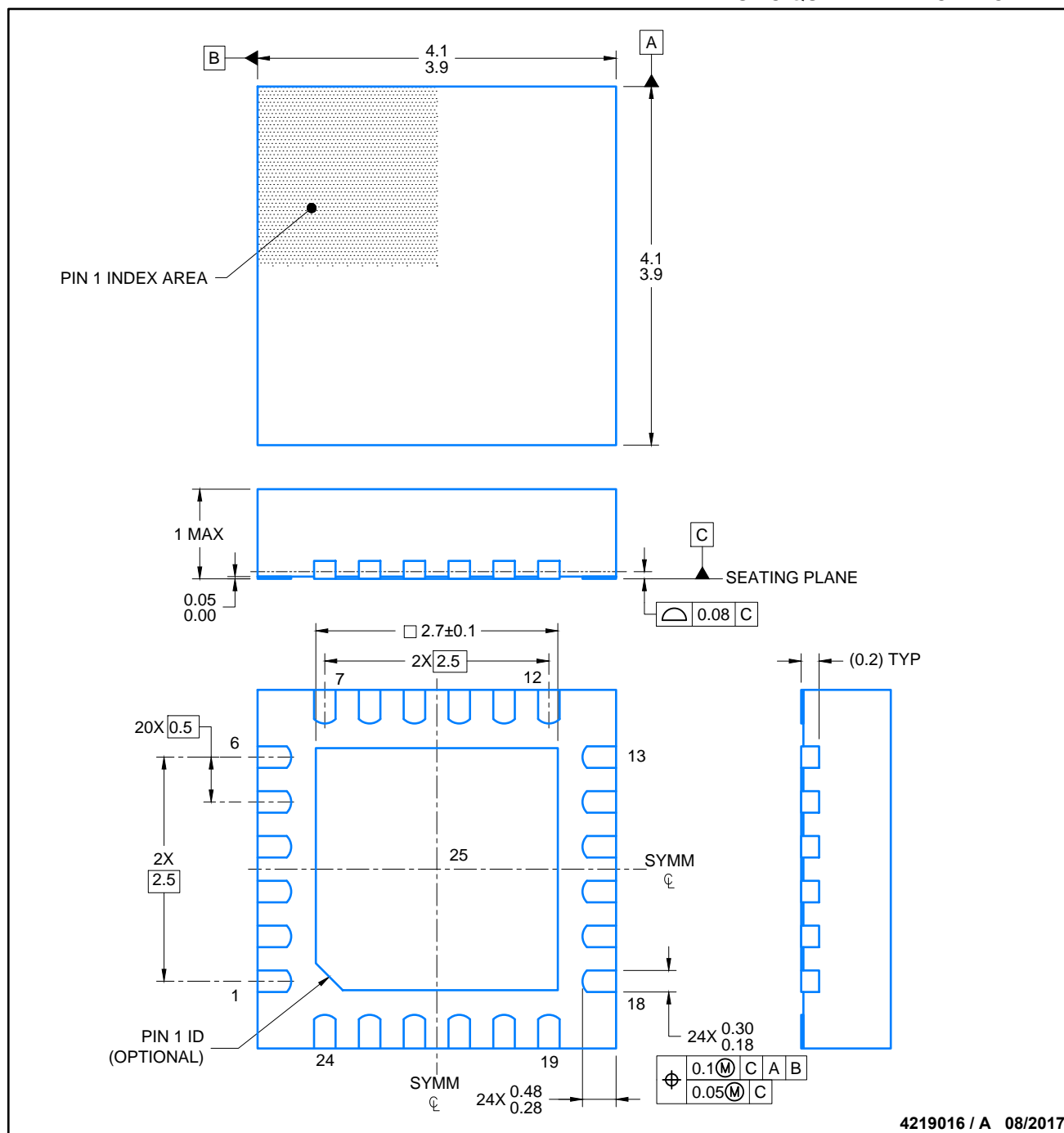

NOTES:

1. All linear dimensions are in millimeters. Any dimensions in parenthesis are for reference only. Dimensioning and tolerancing per ASME Y14.5M.
2. This drawing is subject to change without notice.
3. The package thermal pad must be soldered to the printed circuit board for thermal and mechanical performance.



LAND PATTERN EXAMPLE  
SCALE: 20X



4219016 / A 08/2017

NOTES: (continued)

4. This package is designed to be soldered to a thermal pad on the board. For more information, see Texas Instruments literature number SLUA271 ([www.ti.com/lit/slua271](http://www.ti.com/lit/slua271)).
5. Solder mask tolerances between and around signal pads can vary based on board fabrication site.



NOTES: (continued)

6. Laser cutting apertures with trapezoidal walls and rounded corners may offer better paste release. IPC-7525 may have alternate design recommendations..

## IMPORTANT NOTICE AND DISCLAIMER

TI PROVIDES TECHNICAL AND RELIABILITY DATA (INCLUDING DATASHEETS), DESIGN RESOURCES (INCLUDING REFERENCE DESIGNS), APPLICATION OR OTHER DESIGN ADVICE, WEB TOOLS, SAFETY INFORMATION, AND OTHER RESOURCES "AS IS" AND WITH ALL FAULTS, AND DISCLAIMS ALL WARRANTIES, EXPRESS AND IMPLIED, INCLUDING WITHOUT LIMITATION ANY IMPLIED WARRANTIES OF MERCHANTABILITY, FITNESS FOR A PARTICULAR PURPOSE OR NON-INFRINGEMENT OF THIRD PARTY INTELLECTUAL PROPERTY RIGHTS.

These resources are intended for skilled developers designing with TI products. You are solely responsible for (1) selecting the appropriate TI products for your application, (2) designing, validating and testing your application, and (3) ensuring your application meets applicable standards, and any other safety, security, or other requirements. These resources are subject to change without notice. TI grants you permission to use these resources only for development of an application that uses the TI products described in the resource. Other reproduction and display of these resources is prohibited. No license is granted to any other TI intellectual property right or to any third party intellectual property right. TI disclaims responsibility for, and you will fully indemnify TI and its representatives against, any claims, damages, costs, losses, and liabilities arising out of your use of these resources.

TI's products are provided subject to TI's Terms of Sale ([www.ti.com/legal/termsofsale.html](http://www.ti.com/legal/termsofsale.html)) or other applicable terms available either on [ti.com](http://ti.com) or provided in conjunction with such TI products. TI's provision of these resources does not expand or otherwise alter TI's applicable warranties or warranty disclaimers for TI products.

Mailing Address: Texas Instruments, Post Office Box 655303, Dallas, Texas 75265  
Copyright © 2019, Texas Instruments Incorporated

## Looking for pricing, stock, or lifecycle information?

Click below to explore more details on WIN SOURCE:

 [View BQ24160ARGER on WIN SOURCE](#)

 [Texas Instruments](#) Information

## Optimize Your Supply Chain with WIN SOURCE Solutions

-  Global Sourcing Solution
-  Obsolete Management
-  Cost Control Management
-  Shortage Management
-  Alternative Solution
-  Excess Inventory Management