



**THE DATASHEET OF
BQ24081DRCT**



BQ24080, BQ24081 1-A, Single-Chip, Li-Ion and Li-Pol Charger IC

1 Features

- Integrated Power FET and Current Sensor for Up to 1-A Charge Applications From AC Adapter
- Precharge Conditioning With Safety Timer
- Charge and Power-Good Status Output
- Automatic Sleep Mode for Low Power Consumption
- Integrated Charge-Current Monitor
- Fixed 7-Hour Fast Charge Safety Timer
- Ideal for Low-Dropout Charger Designs for Single-Cell Li-Ion or Li-Pol Packs in Space-Limited Portable Applications
- Small 3.00-mm × 3.00-mm VSON Package

2 Applications

- PDAs, MP3 Players
- Digital Cameras
- Internet Appliances
- Smartphones

3 Description

The bq24080 and bq24081 are highly integrated and flexible Li-Ion linear charge devices targeted at space-limited charger applications. They offer an integrated power FET and current sensor, high-accuracy current and voltage regulation, charge status, and charge termination, in a single monolithic device. An external resistor sets the magnitude of the charge current.

The device charges the battery in three phases: conditioning, constant current, and constant voltage. Charge is terminated based on minimum current. An internal charge timer provides a backup safety for charge termination. The device automatically restarts the charge if the battery voltage falls below an internal threshold. The device automatically enters sleep mode when the ac adapter is removed.

Device Information⁽¹⁾

PART NUMBER	PACKAGE	BODY SIZE (NOM)
bq24080	VSON (10)	3.00 mm × 3.00 mm
bq24081		

(1) For all available packages, see the orderable addendum at the end of the data sheet.

Typical Application

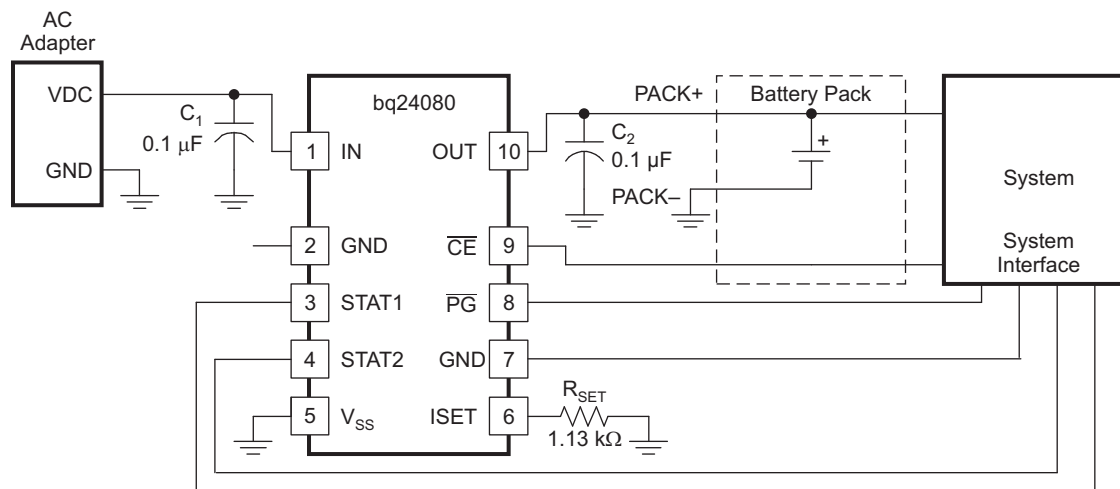

Copyright © 2017, Texas Instruments Incorporated



Table of Contents

1 Features	1	7.4 Device Functional Modes.....	14
2 Applications	1	8 Application and Implementation	15
3 Description	1	8.1 Application Information.....	15
4 Revision History	2	8.2 Typical Application	15
5 Pin Configuration and Functions	3	9 Power Supply Recommendations	17
6 Specifications	4	10 Layout	18
6.1 Absolute Maximum Ratings	4	10.1 Layout Guidelines	18
6.2 ESD Ratings.....	4	11 Device and Documentation Support	20
6.3 Recommended Operating Conditions.....	4	11.1 Documentation Support	20
6.4 Thermal Information	4	11.2 Related Links	20
6.5 Electrical Characteristics.....	5	11.3 Receiving Notification of Documentation Updates	20
6.6 Typical Characteristics.....	7	11.4 Community Resources.....	20
7 Detailed Description	8	11.5 Trademarks	20
7.1 Overview	8	11.6 Electrostatic Discharge Caution.....	20
7.2 Functional Block Diagram	10	11.7 Glossary	20
7.3 Feature Description.....	11	12 Mechanical, Packaging, and Orderable Information	20

4 Revision History

NOTE: Page numbers for previous revisions may differ from page numbers in the current version.

Changes from Revision E (August 2011) to Revision F	Page
• Added <i>ESD Ratings</i> table, <i>Feature Description</i> section, <i>Device Functional Modes</i> , <i>Application and Implementation</i> section, <i>Power Supply Recommendations</i> section, <i>Layout</i> section, <i>Device and Documentation Support</i> section, and <i>Mechanical, Packaging, and Orderable Information</i> section.	1
• Changed pins 2 and 7 to GND in the Typical Application image	1

5 Pin Configuration and Functions

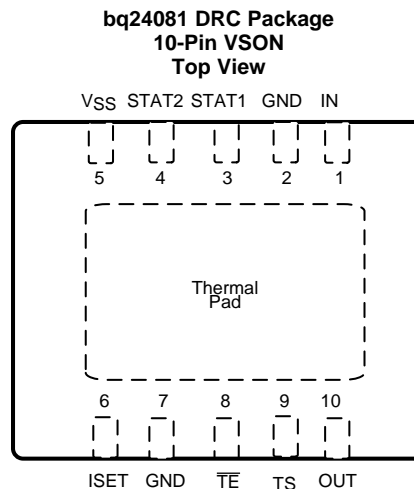
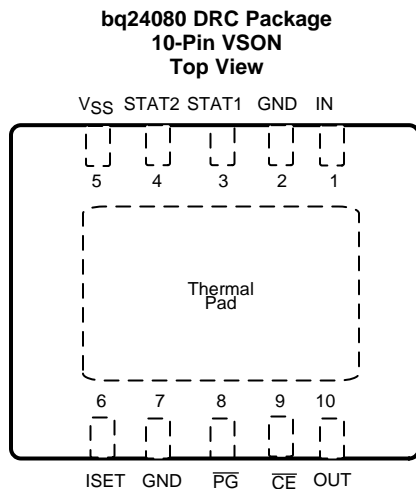

Pin Functions

NAME	PIN		I/O	DESCRIPTION
	NO.			
	bq24080	bq24081		
IN	1	1	I	Adapter dc voltage. Connect minimum 0.1- μ F capacitor to V_{SS} .
GND	2, 7	2, 7	–	Ground
STAT1	3	3	O	Charge status outputs (open-drain)
STAT2	4	4	O	
V_{SS}	5	5	–	Ground
ISET	6	6	I	Charge current. External resistor to V_{SS} sets precharge and fast-charge current, and also the termination current value. Can be used to monitor the charge current.
\overline{PG}	8	–	O	Power-good status output (open-drain)
\overline{TE}	–	8	I	Timer-enable input (active-low)
TS	–	9	I/O	Temperature sense; connect to NTC in battery pack.
\overline{CE}	9	–	I	Charge enable input (active-low)
OUT	10	10	O	Charge current output. Connect minimum 0.1- μ F capacitor to V_{SS} .
Thermal pad	–	–	–	There is an internal electrical connection between the exposed thermal pad and the V_{SS} pin of the device. The exposed thermal pad must be connected to the same potential as the V_{SS} pin on the printed-circuit board. Do not use the thermal pad as the primary ground input for the device. The V_{SS} pin must be connected to ground at all times.

6 Specifications

6.1 Absolute Maximum Ratings

over operating free-air temperature range (unless otherwise noted)⁽¹⁾

			MIN	MAX	UNIT
V _I	Input voltage ⁽²⁾	IN, \overline{CE} , ISET, OUT, \overline{PG} , STAT1, STAT2, \overline{TE} , TS	-0.3	7	V
	Output sink/source current	STAT1, STAT2, \overline{PG}		15	mA
	Output current	OUT		1.5	A
T _A	Operating free-air temperature range		-40	125	°C
T _J	Junction temperature range				°C
T _{stg}	Storage temperature		-65	150	°C

- (1) Stresses beyond those listed under *Absolute Maximum Ratings* may cause permanent damage to the device. These are stress ratings only, which do not imply functional operation of the device at these or any other conditions beyond those indicated under *Recommended Operating Conditions*. Exposure to absolute-maximum-rated conditions for extended periods may affect device reliability.
- (2) All voltages are with respect to V_{SS}.

6.2 ESD Ratings

			VALUE	UNIT
V _(ESD)	Electrostatic discharge	Human-body model (HBM), per ANSI/ESDA/JEDEC JS-001 ⁽¹⁾	±2000	V
		Charged-device model (CDM), per JEDEC specification JESD22-C101 ⁽²⁾	±500	

- (1) JEDEC document JEP155 states that 500-V HBM allows safe manufacturing with a standard ESD control process.
- (2) JEDEC document JEP157 states that 250-V CDM allows safe manufacturing with a standard ESD control process.

6.3 Recommended Operating Conditions

over operating free-air temperature range (unless otherwise noted)

			MIN	MAX	UNIT
V _{CC}	Supply voltage		4.5	6.5	V
T _J	Operating junction temperature range		0	125	°C

6.4 Thermal Information

THERMAL METRIC ⁽¹⁾		bq2408x	UNIT
		DRC (VSON)	
		10 PINS	
R _{θJA}	Junction-to-ambient thermal resistance	49.4	°C/W
R _{θJC(top)}	Junction-to-case (top) thermal resistance	69.8	°C/W
R _{θJB}	Junction-to-board thermal resistance	23.9	°C/W
Ψ _{JT}	Junction-to-top characterization parameter	2.1	°C/W
Ψ _{JB}	Junction-to-board characterization parameter	24.1	°C/W
R _{θJC(bot)}	Junction-to-case (bottom) thermal resistance	6.1	°C/W

- (1) For more information about traditional and new thermal metrics, see the [Semiconductor and IC Package Thermal Metrics](#) application report.

6.5 Electrical Characteristics

over $0^{\circ}\text{C} \leq T_J \leq 125^{\circ}\text{C}$ and recommended supply voltage (unless otherwise noted)

PARAMETER		TEST CONDITIONS	MIN	TYP	MAX	UNIT
INPUT CURRENT						
$I_{CC(VCC)}$	V_{CC} current	$V_{CC} > V_{CC(MIN)}$		1.2	2	mA
$I_{CC(SLP)}$	Sleep current	Sum of currents into OUT pin, $V_{CC} < V_{(SLP)}$		2	5	μA
$I_{CC(STBY)}$	Standby current	$\overline{CE} = \text{High}, 0^{\circ}\text{C} \leq T_J \leq 85^{\circ}\text{C}$			150	
$I_{IB(OUT)}$	Input current on OUT pin	Charge DONE, $V_{CC} > V_{CC(MIN)}$		1	5	
VOLTAGE REGULATION $V_{O(REG)} + V_{(DO-MAX)} \leq V_{CC}, I_{(TERM)} < I_{O(OUT)} \leq 1 \text{ A}$						
$V_{O(REG)}$	Output voltage			4.2		V
	Voltage regulation accuracy	$T_A = 25^{\circ}\text{C}$	-0.35%		0.35%	
			-1%		1%	
$V_{(DO)}$	Dropout voltage ($V_{(IN)} - V_{(OUT)}$)	$V_{O(OUT)} = V_{O(REG)}, I_{O(OUT)} = 1 \text{ A}$ $V_{O(REG)} + V_{(DO)} \leq V_{CC}$		350	500	mV
CURRENT REGULATION						
$I_{O(OUT)}$	Output current range ⁽¹⁾	$V_{I(OUT)} > V_{(LOWV)},$ $V_{I(IN)} - V_{I(OUT)} > V_{(DO)},$ $V_{CC} \geq 4.5 \text{ V}$	20		1000	mA
$V_{(SET)}$	Output current set voltage	Voltage on ISET pin, $V_{CC} \geq 4.5 \text{ V},$ $V_I \geq 4.5 \text{ V}, V_{I(OUT)} > V_{(LOWV)},$ $V_I - V_{I(OUT)} > V_{(DO)}$	2.463	2.5	2.538	V
$K_{(SET)}$	Output current set factor	$50 \text{ mA} \leq I_{O(OUT)} \leq 1 \text{ A}$	307	322	337	
		$10 \text{ mA} \leq I_{O(OUT)} < 50 \text{ mA}$	296	320	346	
		$1 \text{ mA} \leq I_{O(OUT)} < 10 \text{ mA}$	246	320	416	
PRECHARGE AND SHORT-CIRCUIT CURRENT REGULATION						
$V_{(LOWV)}$	Precharge to fast-charge transition threshold	Voltage on OUT pin	2.8	3	3.2	V
	Deglintch time for fast-charge to precharge transition	$V_{CC(MIN)} \geq 4.5 \text{ V}, t_{FALL} = 100 \text{ ns},$ 10-mV overdrive, $V_{I(OUT)}$ decreasing below threshold	250	375	500	ms
$I_{O(PRECHG)}$	Precharge range ⁽²⁾	$0 \text{ V} < V_{I(OUT)} < V_{(LOWV)}, t < t_{(PRECHG)}$	2		100	mA
$V_{(PRECHG)}$	Precharge set voltage	Voltage on ISET pin, $V_{O(REG)} = 4.2 \text{ V},$ $0 \text{ V} < V_{I(OUT)} > V_{(LOWV)}, t < t_{(PRECHG)}$	240	255	270	mV
TERMINATION DETECTION						
$I_{(TERM)}$	Charge termination detection range ⁽³⁾	$V_{I(OUT)} > V_{(RCH)}, t < t_{(TRMDET)}$	2		100	mA
$V_{(TERM)}$	Charge termination detection set voltage	Voltage on ISET pin, $V_{O(REG)} = 4.2 \text{ V},$ $V_{I(OUT)} > V_{(RCH)}, t < t_{(TRMDET)}$	235	250	265	mV
t_{TRMDET}	Deglintch time for termination detection	$V_{CC(MIN)} \geq 4.5 \text{ V}, t_{FALL} = 100 \text{ ns}$ charging current decreasing below 10-mV overdrive	250	375	500	ms

(1) See Equation 2 in the Function Description section.

(2) See Equation 1 in the Function Description section.

(3) See Equation 4 in the Function Description section.

Electrical Characteristics (continued)

over $0^{\circ}\text{C} \leq T_J \leq 125^{\circ}\text{C}$ and recommended supply voltage (unless otherwise noted)

PARAMETER		TEST CONDITIONS	MIN	TYP	MAX	UNIT
BATTERY RECHARGE THRESHOLD						
$V_{(RCH)}$	Recharge threshold		$V_{O(REG)} - 0.115$	$V_{O(REG)} - 0.10$	$V_{O(REG)} - 0.085$	V
$t_{(DEGL)}$	Deglintch time for recharge detect	$V_{CC(MIN)} \geq 4.5\text{ V}$, $t_{FALL} = 100\text{ ns}$ decreasing below or increasing above threshold, 10-mV overdrive	250	375	500	ms
STAT1, STAT2, and $\overline{\text{PG}}$ OUTPUTS						
V_{OL}	Low-level output saturation voltage	$I_O = 5\text{ mA}$			0.25	V
$\overline{\text{CE}}$ and $\overline{\text{TE}}$ INPUTS						
V_{IL}	Low-level input voltage		0		0.4	V
V_{IH}	High-level input voltage		1.4			
I_{IL}	Low-level input current		-1			μA
I_{IH}	High-level input current				1	
TIMERS						
$t_{(PRECHG)}$	Precharge time		1,584	1,800	2,016	s
$t_{(CHG)}$	Charge time		22,176	25,200	28,224	s
$I_{(FAULT)}$	Timer fault recovery current			200		μA
SLEEP COMPARATOR						
$V_{(SLP)}$	Sleep-mode entry threshold voltage	$2.3\text{ V} \leq V_{I(OUT)} \leq V_{O(REG)}$	$V_{CC} \leq V_{I(OUT)} + 80\text{ mV}$			V
$V_{(SLPEXIT)}$	Sleep-mode exit threshold voltage		$V_{CC} \geq V_{I(OUT)} + 190$			
	Sleep-mode entry deglintch time	$V_{(IN)}$ decreasing below threshold, $t_{FALL} = 100\text{ ns}$, 10-mV overdrive	250	375	500	ms
THERMAL SHUTDOWN THRESHOLDS						
$T_{(SHTDWN)}$	Thermal trip threshold	T_J increasing	165			$^{\circ}\text{C}$
	Thermal hysteresis		15			
UNDERVOLTAGE LOCKOUT						
$UVLO$	Undervoltage lockout	Decreasing V_{CC}	2.4	2.5	2.6	V
	Hysteresis		27			mV
TEMPERATURE SENSE COMPARATOR (bq24081)						
$V_{(TS1)}$	High-voltage threshold		2.475	2.5	2.525	V
$V_{(TS2)}$	Low-voltage threshold		0.485	0.5	0.515	
$I_{(TS)}$	TS pin current source		96	102	108	μA
$t_{(DEGL)}$	Deglintch time for temperature fault		250	375	500	ms

6.6 Typical Characteristics

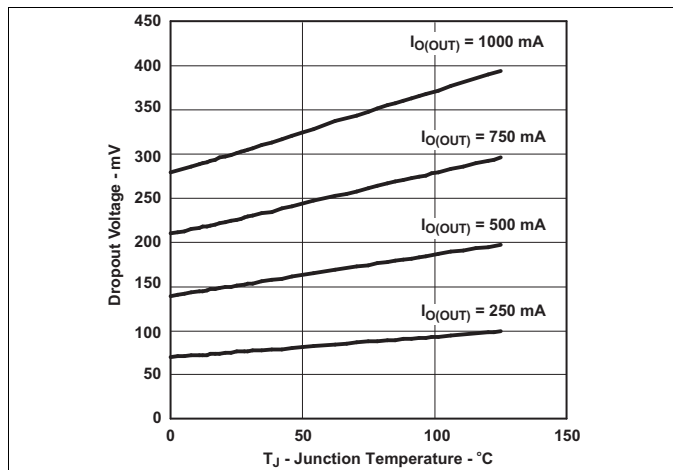

Figure 1. Dropout Voltage vs Junction Temperature

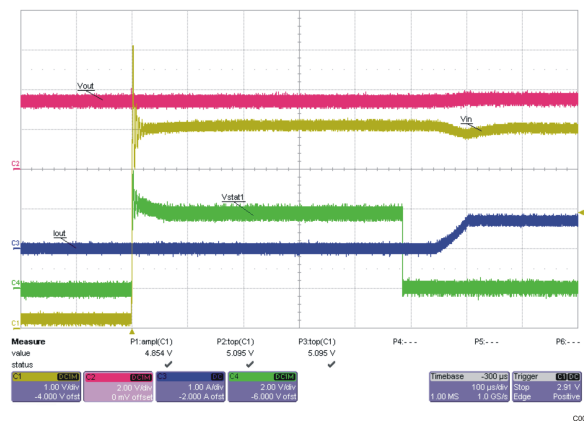

Figure 2. V_{IN} Hot-Plug Power-Up Sequence

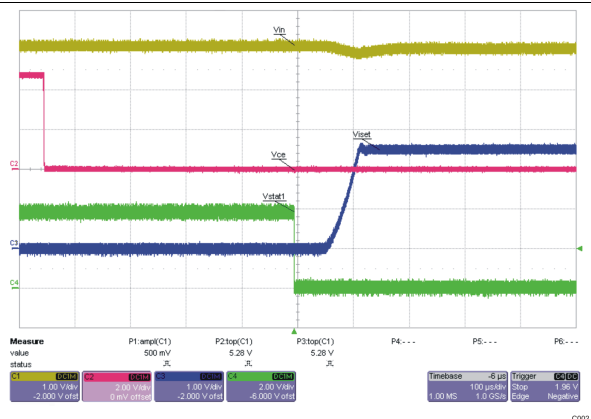

Figure 3. Charge Enable Power-Up Sequence (CE = High-to-Low)

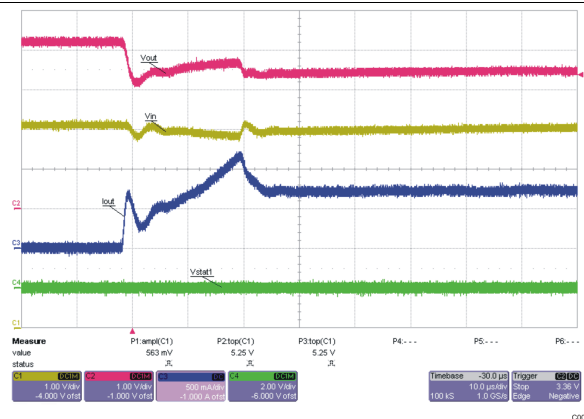
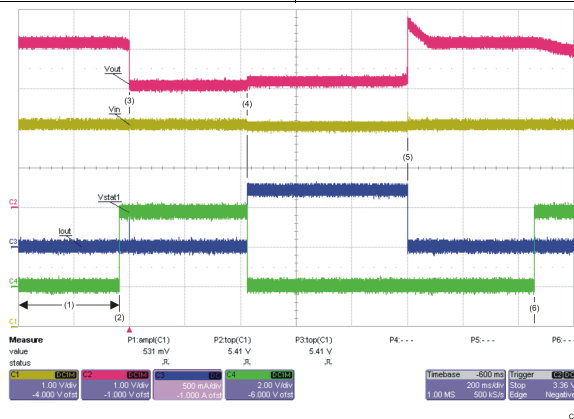

Figure 4. Battery Hot-Plug During Charging Phase



No battery – In termination deglitch prior to STAT1 going high. V_{OUT} (V_{BAT}) cycling between *charge* and *done* prior to screen capture
 Stat1 goes high – In *done* state
 2-V battery is inserted during the *charge done* state.
 Charging is initiated – STAT1 goes low and charge current is applied.
 Battery is removed – V_{OUT} goes into regulation, I_{O(OUT)} goes to zero, and termination deglitch timer starts running (same as state 1).
 Deglitch timer expires – *charge done* is declared.

Figure 5. Battery Hot-Plug and Removal Power Sequence

7 Detailed Description

7.1 Overview

The device supports a precision Li-Ion, Li-Pol charging system suitable for single cells. [Figure 6](#) shows a typical charge profile, and [Figure 7](#) shows an operational flow chart.

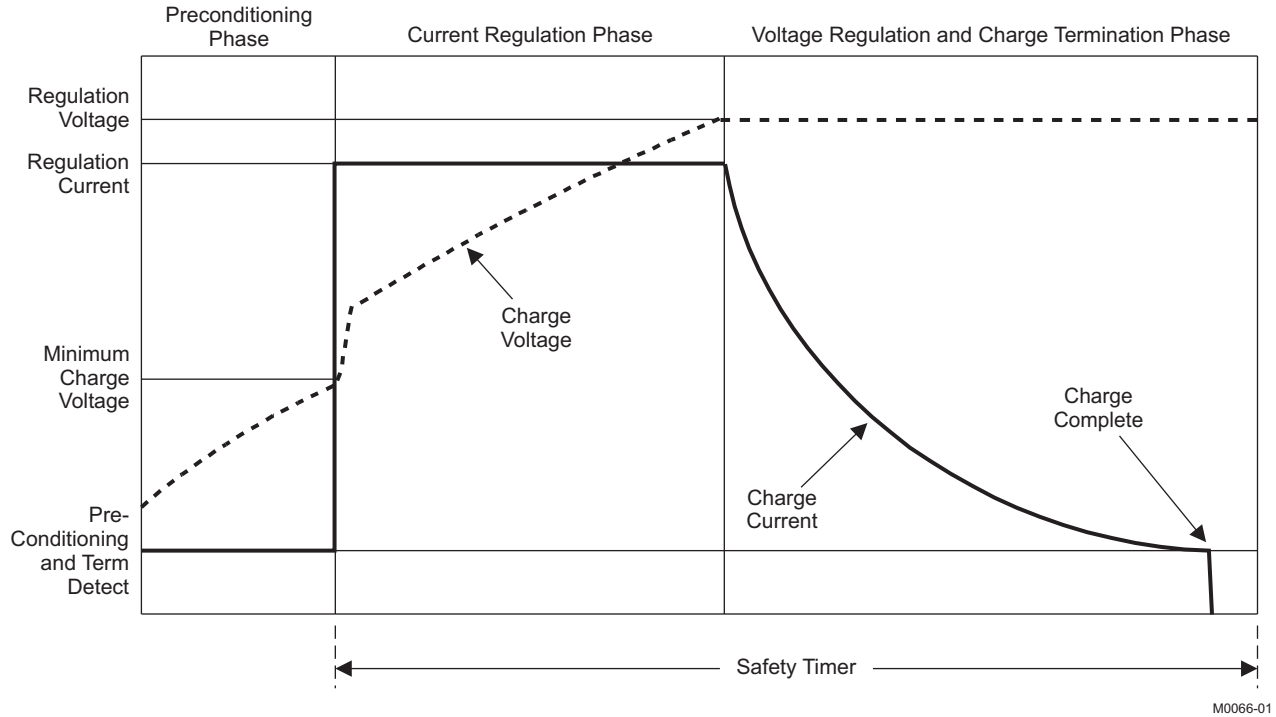
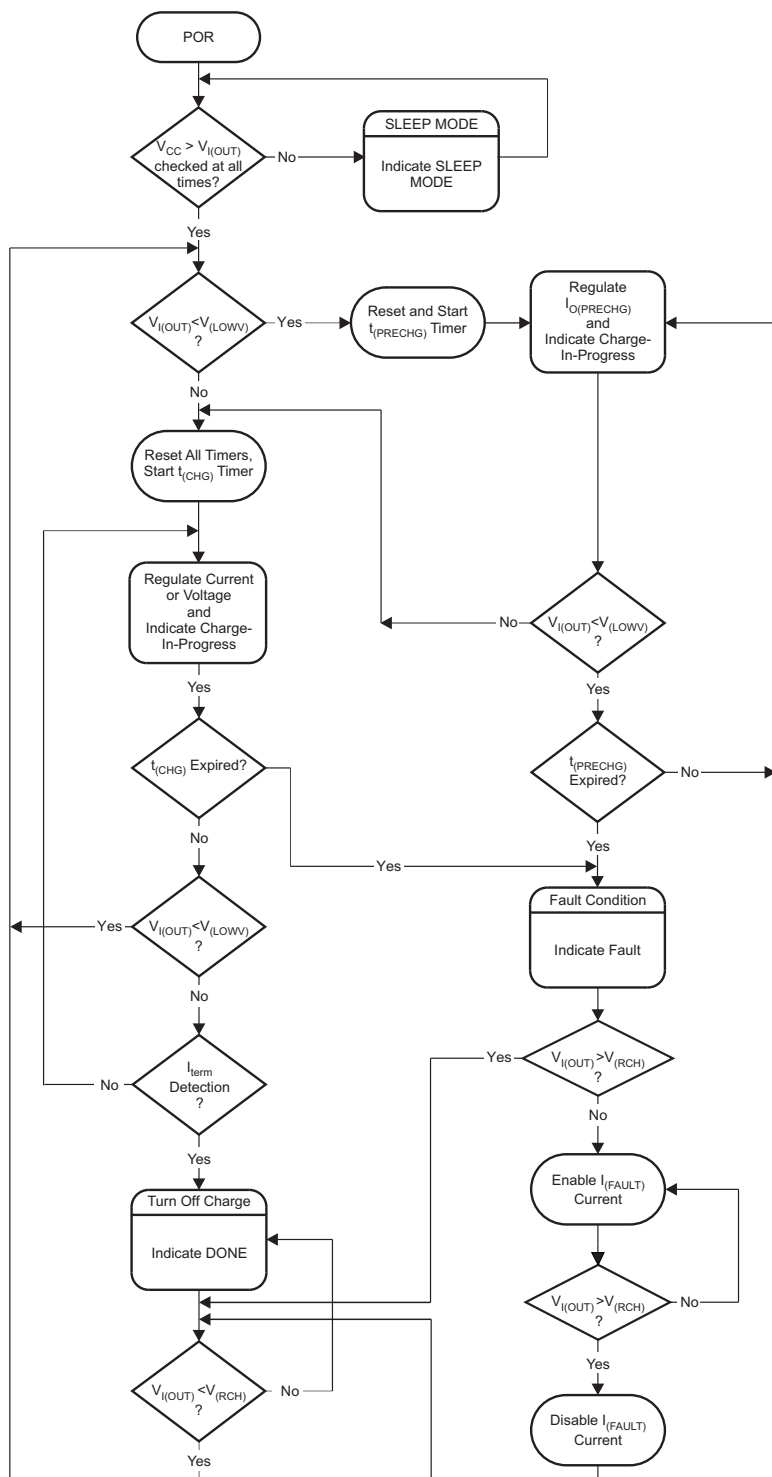

Figure 6. Typical Charging Profile

Overview (continued)



F0018-01

Figure 7. Operational Flow Chart

7.2 Functional Block Diagram

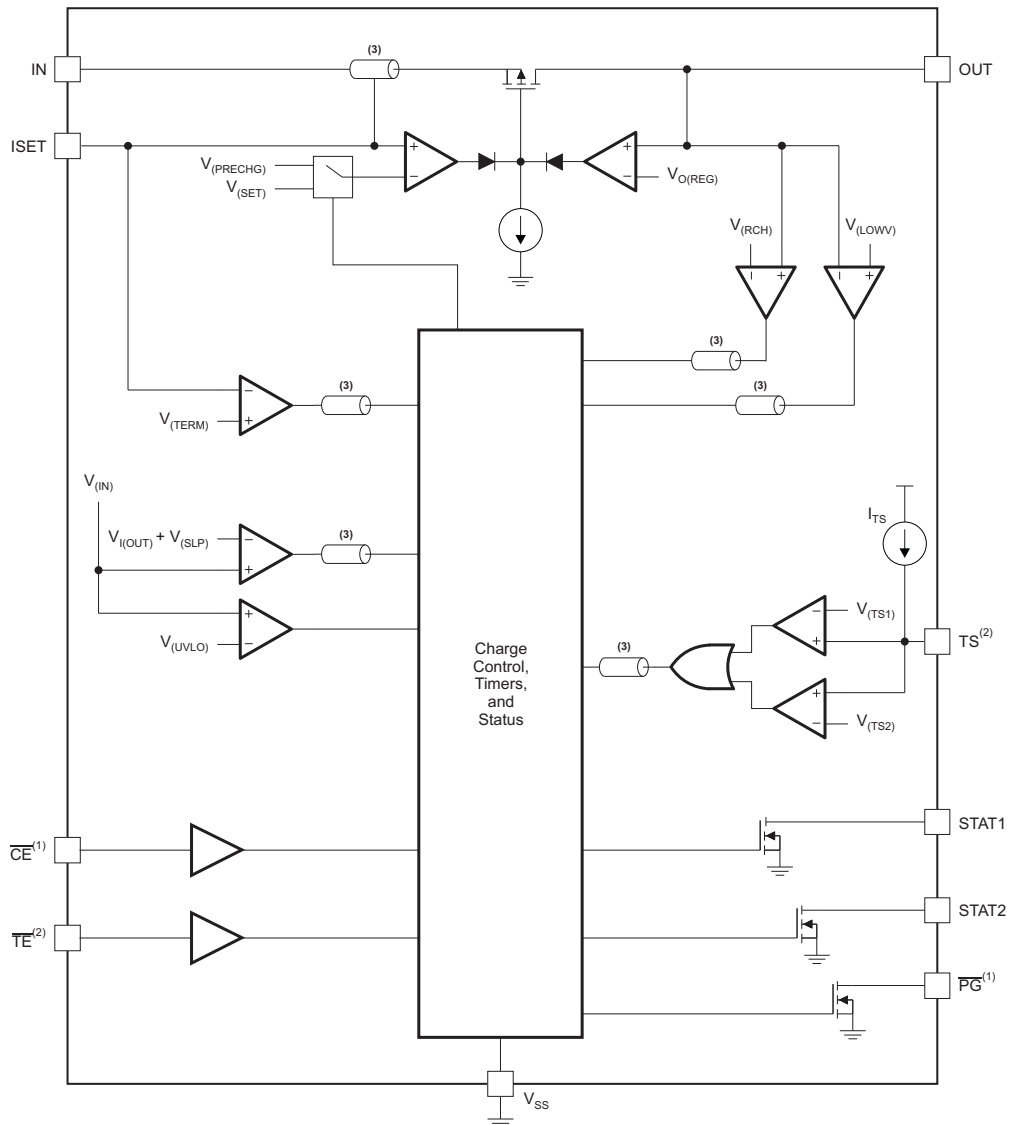

B0193-01

- (1) bq24080 only
- (2) bq24081 only
- (3) Signal deglitched

7.3 Feature Description

7.3.1 Battery Preconditioning

During a charge cycle, if the battery voltage is below the $V_{(LOWV)}$ threshold, the device applies a precharge current, $I_{O(PRECHG)}$, to the battery. This feature revives deeply discharged cells. Resistor R_{SET} , connected between the ISET and V_{SS} , determines the precharge rate. The $V_{(PRECHG)}$ and $K_{(SET)}$ parameters are specified in the [Electrical Characteristics](#) table.

$$I_{O(PRECHG)} = \frac{K_{(SET)} \times V_{(PRECHG)}}{R_{SET}} \quad (1)$$

The device activates a safety timer, $t_{(PRECHG)}$, during the conditioning phase. If the $V_{(LOWV)}$ threshold is not reached within the timer period, the device turns off the charger and enunciates FAULT on the STATx pins. See the [Timer Fault and Recovery](#) section for additional details.

7.3.2 Battery Fast-Charge Constant Current

The device offers on-chip current regulation with programmable set point. Resistor R_{SET} , connected between the ISET and V_{SS} , determines the charge rate. The $V_{(SET)}$ and $K_{(SET)}$ parameters are specified in the [Electrical Characteristics](#) table.

$$I_{O(OUT)} = \frac{K_{(SET)} \times V_{(SET)}}{R_{SET}} \quad (2)$$

7.3.3 Charge-Current Monitor

When the charge function is enabled internal circuits generate a current proportional to the charge current at the ISET pin. This current, when applied to the external charge current programming resistor R_{ISET} generates an analog voltage that can be monitored by an external host to calculate the current sourced from the OUT pin.

$$V_{(ISET)} = I_{(OUT)} \times \frac{R_{(ISET)}}{K_{(ISET)}} \quad (3)$$

7.3.4 Battery Fast-Charge Voltage Regulation

The voltage regulation feedback is through the OUT pin. This input is tied directly to the positive side of the battery pack. The device monitors the battery-pack voltage between the OUT and V_{SS} pins. When the battery voltage rises to the $V_{O(REG)}$ threshold, the voltage regulation phase begins and the charging current begins to taper down.

As a safety backup, the device also monitors the charge time in the charge mode. If charge is not terminated within this time period, $t_{(CHG)}$, the charger is turned off and FAULT is set on the STATx pins. See the [Timer Fault and Recovery](#) section for additional details.

7.3.5 Charge Termination Detection and Recharge

The device monitors the charging current during the voltage regulation phase. Once the termination threshold, $I_{(TERM)}$, is detected, charge is terminated. The $V_{(TERM)}$ and $K_{(SET)}$ parameters are specified in the [Electrical Characteristics](#) table.

$$I_{O(TERM)} = \frac{K_{(SET)} \times V_{(TERM)}}{R_{SET}} \quad (4)$$

After charge termination, the device restarts the charge once the voltage on the OUT pin falls below the $V_{(RCH)}$ threshold. This feature keeps the battery at full capacity at all times.

The device monitors the charging current during the voltage regulation phase. Once the termination threshold, $I_{(TERM)}$, is detected, the charge is terminated immediately.

Resistor R_{SET} , connected between the ISET and V_{SS} , determines the current level at the termination threshold.

Feature Description (continued)

7.3.6 Charge Status Outputs

The open-drain STAT1 and STAT2 outputs indicate various charger operations as shown in [Table 1](#). These status pins can be used to drive LEDs or communicate to the host processor. Note that *OFF* indicates the open-drain transistor is turned off.

Table 1. Status Pin Summary

CHANGE STATE	STAT1	STAT2
Precharge in progress	ON	ON
Fast charge in progress	ON	OFF
Charge done	OFF	ON
Charge suspend (temperature)	OFF	OFF
Timer fault		
Sleep mode		

7.3.7 $\overline{\text{PG}}$ Output (bq24080)

The open-drain power-good ($\overline{\text{PG}}$) output pulls low when a valid input voltage is present. This output is turned off (high-impedance) in sleep mode. The $\overline{\text{PG}}$ pin can be used to drive an LED or communicate to the host processor.

7.3.8 Charge-Enabled ($\overline{\text{CE}}$) Input (bq24080)

The $\overline{\text{CE}}$ digital input is used to disable or enable the charge process. A low-level signal on this pin enables the charge and a high-level signal disables the charge and places the device in a low-power mode. A high-to-low transition on this pin also resets all timers and timer fault conditions.

7.3.9 Timer Enabled ($\overline{\text{TE}}$) Input (bq24081)

The $\overline{\text{TE}}$ digital input is used to disable or enable the fast-charge timer. A low-level signal on this pin enables the fast-charge timer, and a high-level signal disables this feature.

7.3.10 Temperature Qualification (bq24081)

The bq24081 continuously monitors battery temperature by measuring the voltage between the TS and V_{SS} pins. An internal current source provides the bias for common 10-k Ω negative-temperature-coefficient thermistors (NTC) (see the functional block diagram). The device compares the voltage on the TS pin with the internal $V_{(\text{TS}1)}$ and $V_{(\text{TS}2)}$ thresholds to determine if charging is allowed. If a temperature outside the $V_{(\text{TS}1)}$ and $V_{(\text{TS}2)}$ thresholds is detected, the device immediately suspends the charge by turning off the power FET and holding the timer value (i.e., timers are not reset). Charge is resumed when the temperature returns within the normal range.

The allowed temperature range with a 103AT-type thermistor is 0°C to 45°C. However, the user may modify these thresholds by adding external resistors (see [Figure 8](#) and [Figure 9](#)

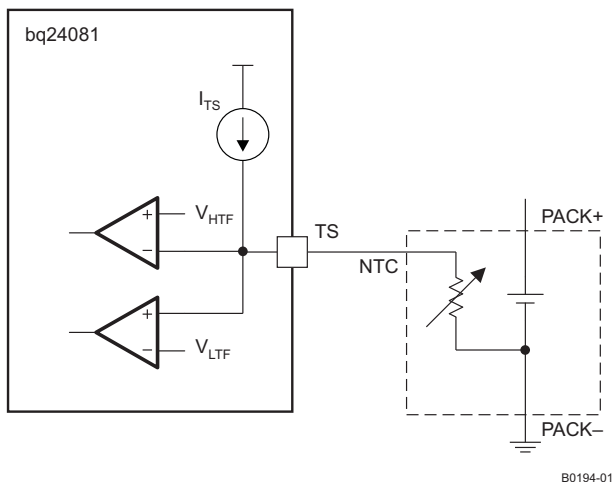

Figure 8. Default Temperature Thresholds

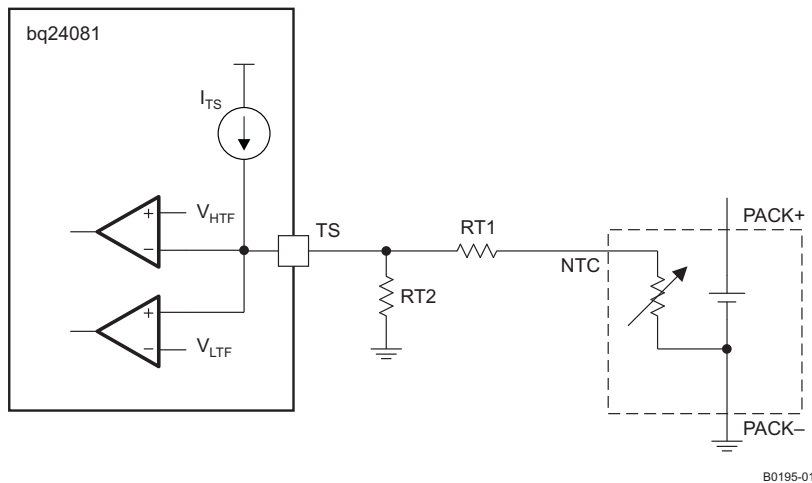

Figure 9. Temperature Thresholds Modified by External Resistors

7.3.11 Timer Fault and Recovery

As shown in Figure 7, the device provides a recovery method to deal with timer fault conditions. The following summarizes this method:

7.3.11.1 Condition Number 1

OUT pin voltage is above the recharge threshold ($V_{(RCH)}$), and a timeout fault occurs.

Recovery method: the device waits for the OUT pin voltage to fall below the recharge threshold. This could happen as a result of a load on the battery, self-discharge, or battery removal. Once the OUT pin voltage falls below the recharge threshold, the device clears the fault and starts a new charge cycle. A POR, \overline{TE} , or CE toggle also clears the fault.

7.3.11.2 Condition Number 2

OUT pin voltage is below the recharge threshold ($V_{(RCH)}$), and a timeout fault occurs

Recovery method: Under this scenario, the device applies the $I_{(FAULT)}$ current. This small current is used to detect a battery removal condition and remains on as long as the battery voltage stays below the recharge threshold. If the OUT pin voltage goes above the recharge threshold, then the device disables the $I_{(FAULT)}$ current and executes the recovery method described for condition number 1. Once the OUT pin voltage falls below the recharge threshold, the bq24080 clears the fault and starts a new charge cycle. A POR, \overline{TE} , or \overline{CE} toggle also clears the fault.

7.4 Device Functional Modes

7.4.1 Sleep Mode

The device enters the low-power sleep mode if the input power (IN) is removed from the circuit. This feature prevents draining the battery during the absence of input supply.

8 Application and Implementation

NOTE

Information in the following applications sections is not part of the TI component specification, and TI does not warrant its accuracy or completeness. TI's customers are responsible for determining suitability of components for their purposes. Customers should validate and test their design implementation to confirm system functionality.

8.1 Application Information

The bq24080 and bq24081 are highly integrated and flexible Li-Ion linear charge devices targeted at space-limited charger applications. They offer an integrated power FET and current sensor, high accuracy current and voltage regulation, charge status, and charge termination, in a single monolithic device. An external resistor sets the magnitude of the charge current.

8.2 Typical Application

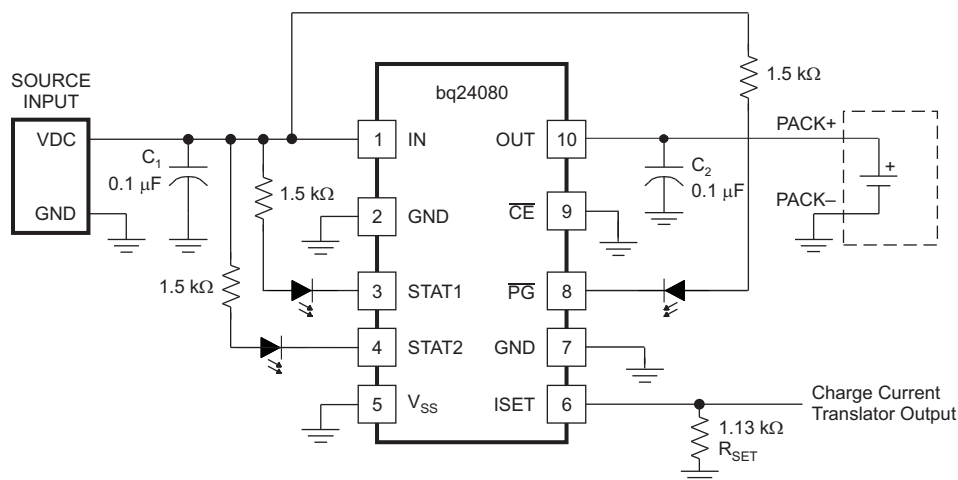

Figure 10. Typical Application Circuit

8.2.1 Design Requirements

For this design example, use the parameters shown in [Table 2](#).

Table 2. Design Parameters

PARAMETER	VALUE
Supply voltage	5 V
Fast-charge current	≈ 750 mA
Battery-Temperature sense (bq24081-Q1)	–2°C to 44.5°C (default setting)

8.2.2 Detailed Design Procedure

8.2.2.1 Calculations

Program the charge current for 750 mA:

$$R_{\text{ISET}} = [V_{(\text{SET})} \times K_{(\text{SET})} / I_{(\text{OUT})}] \quad (5)$$

From [Electrical Characteristics](#) table, $V_{(\text{SET})} = 2.5 \text{ V}$.

From [Electrical Characteristics](#) table, $K_{(\text{SET})} = 322$.

$$R_{\text{ISET}} = [2.5 \text{ V} \times 322 / 0.75 \text{ A}] = 1.073 \text{ k}\Omega \quad (6)$$

Selecting the closest standard value, use a 1.07-k Ω resistor connected between ISET (pin 6) and ground.

8.2.2.2 Battery Temperature Sense (bq24081)

Use a Semitec 103AT-4 NTC thermistor connected between TS (pin 9) and ground.

$$R_{\text{THERM-cold}} = [V_{(\text{TS1})} / I_{(\text{TS})}] = 2.5 \text{ V} / 100 \mu\text{A} = 25 \text{ k}\Omega \quad (7)$$

$$R_{\text{THERM-hot}} = [V_{(\text{TS2})} / I_{(\text{TS})}] = 0.5 \text{ V} / 100 \mu\text{A} = 5 \text{ k}\Omega \quad (8)$$

Look up the corresponding temperature value in the manufacturer's resistance-temperature table for the thermistor selected. For a 103AT-4 Semitec thermistor:

$$5 \text{ k}\Omega = 44.5^\circ\text{C}$$

$$25 \text{ k}\Omega = 2^\circ\text{C}$$

8.2.2.3 STAT Pins (All Devices) and PG Pin (bq24080)

Status pins Monitored by Processor:

Select a pullup resistor that can source more than the input bias (leakage) current of both the processor and status pins and still provide a logic high.

$$R_{\text{PULLUP}} \leq [V_{(\text{CC-pullup})} - V_{(\text{logic hi-min})} / (I_{(\mu\text{P-monitor})} + I_{(\text{STAT-OpenDrain})})] = (3.3 \text{ V} - 1.9 \text{ V}) / (1 \mu\text{A} + 1 \mu\text{A}) \leq 700 \text{ k}\Omega; \quad (9)$$

Connect a 100-k Ω pullup between each status pin and the V_{CC} of the processor. Connect each status pin to a μP monitor pin.

Status viewed by LED:

Select an LED with a current rating less than 10 mA and select a resistor to place in series with the LED to limit the current to the desired current value (brightness).

$$R_{\text{LED}} = [(V_{(\text{IN})} - V_{(\text{LED-on})}) / I_{(\text{LED})}] = (5 \text{ V} - 2 \text{ V}) / 1.5 \text{ mA} = 2 \text{ k}\Omega. \quad (10)$$

Place an LED and resistor in series between the input and each status pin.

8.2.2.4 Selecting Input and Output Capacitors

In most applications, all that is needed is a high-frequency decoupling capacitor on the input power pin. A 0.1- μF ceramic capacitor, placed in close proximity to the IN pin and GND pad works well. In some applications, it may be necessary to protect against a hot plug input voltage overshoot. This is done in three ways:

1. The best way is to add an input zener, 6.2 V, between the IN pin and V_{SS} .
2. A low-power zener is adequate for the single event transient. Increasing the input capacitance lowers the characteristic impedance which makes the input resistance more effective at damping the overshoot, but risks damaging the input contacts by the high inrush current.
3. Placing a resistor in series with the input dampens the overshoot, but causes excess power dissipation.

The device only requires a small capacitor for loop stability. A 0.1- μF ceramic capacitor placed between the OUT and GND pad is typically sufficient.

8.2.3 Application Curves

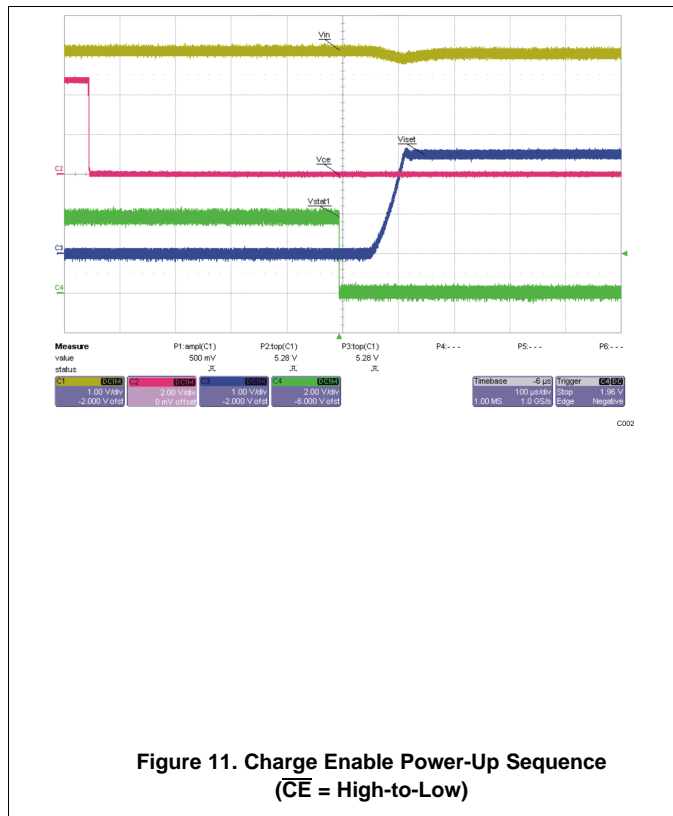
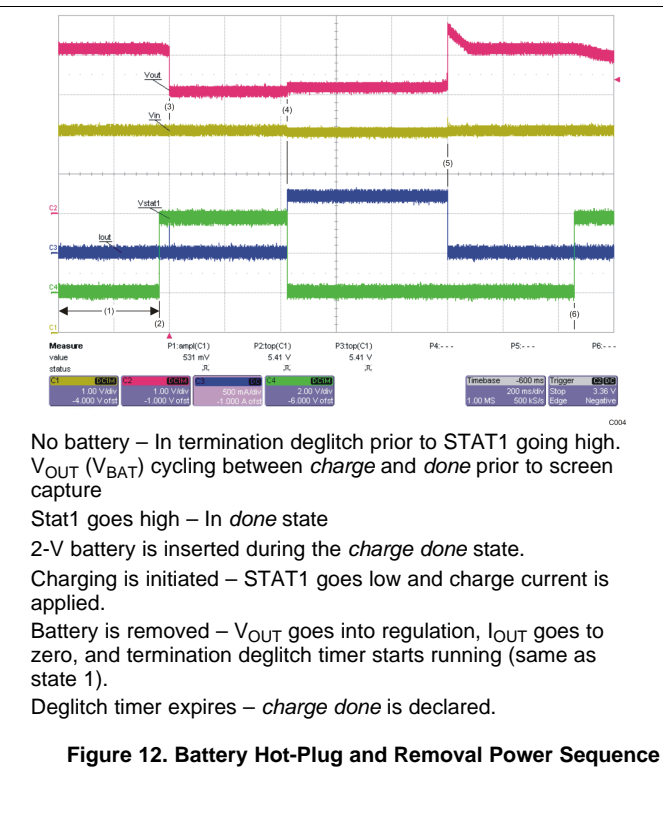

Figure 11. Charge Enable Power-Up Sequence
(\overline{CE} = High-to-Low)



No battery – In termination deglitch prior to STAT1 going high.
 V_{OUT} (V_{BAT}) cycling between *charge* and *done* prior to screen capture
 Stat1 goes high – In *done* state
 2-V battery is inserted during the *charge done* state.
 Charging is initiated – STAT1 goes low and charge current is applied.
 Battery is removed – V_{OUT} goes into regulation, I_{OUT} goes to zero, and termination deglitch timer starts running (same as state 1).
 Deglitch timer expires – *charge done* is declared.

Figure 12. Battery Hot-Plug and Removal Power Sequence

9 Power Supply Recommendations

The devices are intended to operate within the ranges shown in Recommended Operating Conditions. Because the input of the device on pin IN is subject to a power source that is external, care must be taken to not exercise the pin above the Absolute Maximum Rating of the Pin shown in the [Absolute Maximum Ratings](#) table.

10 Layout

10.1 Layout Guidelines

10.1.1 Layout Guidelines

It is important to pay special attention to the PCB layout. The following provides some guidelines:

- To obtain optimal performance, the decoupling capacitor from V_{CC} to $V_{(IN)}$ and the output filter capacitors from OUT to V_{SS} should be placed as close as possible to the device, with short trace runs to both signal and V_{SS} pins. The V_{SS} pin should have short trace runs to the GND pin.
- All low-current V_{SS} connections should be kept separate from the high-current charge or discharge paths from the battery. Use a single-point ground technique incorporating both the small-signal ground path and the power ground path.
- The high-current charge paths into IN and from the OUT pins must be sized appropriately for the maximum charge current in order to avoid voltage drops in these traces.
- The device is packaged in a thermally enhanced MLP package. The package includes a thermal pad to provide an effective thermal contact between the device and the printed circuit board (PCB). Full PCB design guidelines for this package are provided in the application report entitled, *QFN/SOP PCB Attachment* (TI Literature Number [SLUA271](#)).

10.1.2 Layout Example

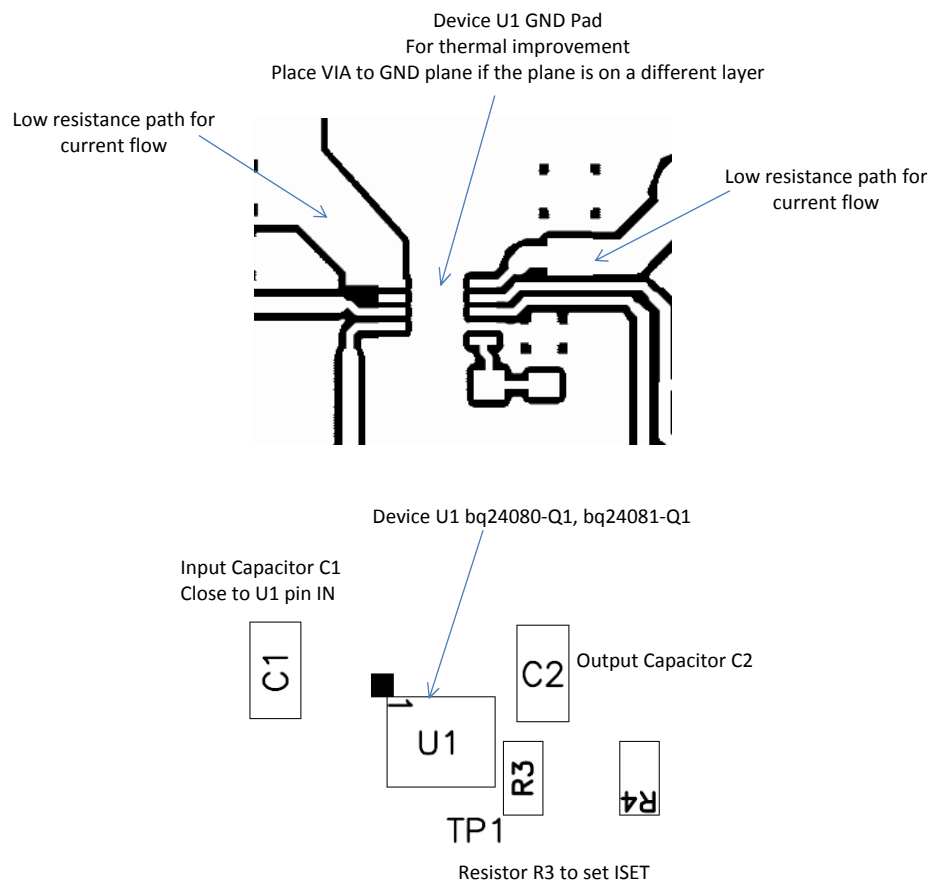

Figure 13. Board Layout

Layout Guidelines (continued)

10.1.3 Thermal Considerations

The bq24080 and bq24081 are packaged in a thermally enhanced MLP package. The package includes a thermal pad to provide an effective thermal contact between the device and the printed-circuit board (PCB). Full PCB design guidelines for this package are provided in the application report entitled, *QFN/SON PCB Attachment* (TI Literature Number [SLUA271](#)).

The most common measure of package thermal performance is thermal impedance ($R_{\theta JA}$) measured (or modeled) from the device junction to the air surrounding the package surface (ambient). The mathematical expression for $R_{\theta JA}$ is:

$$R_{\theta JA} = \frac{T_J - T_A}{P} \quad (11)$$

Where:

- T_J = device junction temperature
- T_A = ambient temperature
- P = device power dissipation

Factors that can greatly influence the measurement and calculation of $R_{\theta JA}$ include:

- Orientation of the device (horizontal or vertical)
- Volume of the ambient air surrounding the device under test and airflow
- Whether other surfaces are in close proximity to the device being tested
- Use multiple 10–13 mil vias in the PowerPAD™ to copper ground plane.
- Avoid cutting the ground plane with a signal trace near the power IC.
- The PCB must be sized to have adequate surface area for heat dissipation.
- FR4 (figerglass) thickness should be minimized.

The device power dissipation, P , is a function of the charge rate and the voltage drop across the internal Power FET. It can be calculated from the following equation:

$$P = (V_{(IN)} - V_{(OUT)}) \times I_{O(OUT)} \quad (12)$$

Due to the charge profile of Li-xx batteries, the maximum power dissipation is typically seen at the beginning of the charge cycle when the battery voltage is at its lowest. See [Figure 6](#).

11 Device and Documentation Support

11.1 Documentation Support

QFN/SON PCB Attachment , ([SLUA271](#))

11.2 Related Links

The table below lists quick access links. Categories include technical documents, support and community resources, tools and software, and quick access to sample or buy.

Table 3. Related Links

PARTS	PRODUCT FOLDER	SAMPLE & BUY	TECHNICAL DOCUMENTS	TOOLS & SOFTWARE	SUPPORT & COMMUNITY
bq24080	Click here	Click here	Click here	Click here	Click here
bq24081	Click here	Click here	Click here	Click here	Click here

11.3 Receiving Notification of Documentation Updates

To receive notification of documentation updates, navigate to the device product folder on ti.com. In the upper right corner, click on *Alert me* to register and receive a weekly digest of any product information that has changed. For change details, review the revision history included in any revised document.

11.4 Community Resources

The following links connect to TI community resources. Linked contents are provided "AS IS" by the respective contributors. They do not constitute TI specifications and do not necessarily reflect TI's views; see TI's [Terms of Use](#).

TI E2E™ Online Community *TI's Engineer-to-Engineer (E2E) Community*. Created to foster collaboration among engineers. At e2e.ti.com, you can ask questions, share knowledge, explore ideas and help solve problems with fellow engineers.

Design Support *TI's Design Support* Quickly find helpful E2E forums along with design support tools and contact information for technical support.

11.5 Trademarks

PowerPAD, E2E are trademarks of Texas Instruments.
All other trademarks are the property of their respective owners.

11.6 Electrostatic Discharge Caution



These devices have limited built-in ESD protection. The leads should be shorted together or the device placed in conductive foam during storage or handling to prevent electrostatic damage to the MOS gates.

11.7 Glossary

[SLYZ022](#) — *TI Glossary*.

This glossary lists and explains terms, acronyms, and definitions.

12 Mechanical, Packaging, and Orderable Information

The following pages include mechanical, packaging, and orderable information. This information is the most current data available for the designated devices. This data is subject to change without notice and revision of this document. For browser-based versions of this data sheet, refer to the left-hand navigation.

PACKAGING INFORMATION

Orderable Device	Status (1)	Package Type	Package Drawing	Pins	Package Qty	Eco Plan (2)	Lead/Ball Finish (6)	MSL Peak Temp (3)	Op Temp (°C)	Device Marking (4/5)	Samples
BQ24080DRCR	ACTIVE	VSON	DRC	10	3000	Green (RoHS & no Sb/Br)	CU NIPDAU	Level-2-260C-1 YEAR	-40 to 85	BRO	Samples
BQ24080DRCT	ACTIVE	VSON	DRC	10	250	Green (RoHS & no Sb/Br)	CU NIPDAU	Level-2-260C-1 YEAR	-40 to 85	BRO	Samples
BQ24081DRCR	ACTIVE	VSON	DRC	10	3000	Green (RoHS & no Sb/Br)	CU NIPDAU	Level-2-260C-1 YEAR	-40 to 85	BRP	Samples
BQ24081DRCRG4	ACTIVE	VSON	DRC	10	3000	Green (RoHS & no Sb/Br)	CU NIPDAU	Level-2-260C-1 YEAR	-40 to 85	BRP	Samples
BQ24081DRCT	ACTIVE	VSON	DRC	10	250	Green (RoHS & no Sb/Br)	CU NIPDAU	Level-2-260C-1 YEAR	-40 to 85	BRP	Samples
BQ24081DRCTG4	ACTIVE	VSON	DRC	10	250	Green (RoHS & no Sb/Br)	CU NIPDAU	Level-2-260C-1 YEAR	-40 to 85	BRP	Samples

(1) The marketing status values are defined as follows:

ACTIVE: Product device recommended for new designs.

LIFEBUY: TI has announced that the device will be discontinued, and a lifetime-buy period is in effect.

NRND: Not recommended for new designs. Device is in production to support existing customers, but TI does not recommend using this part in a new design.

PREVIEW: Device has been announced but is not in production. Samples may or may not be available.

OBSOLETE: TI has discontinued the production of the device.

(2) **RoHS:** TI defines "RoHS" to mean semiconductor products that are compliant with the current EU RoHS requirements for all 10 RoHS substances, including the requirement that RoHS substance do not exceed 0.1% by weight in homogeneous materials. Where designed to be soldered at high temperatures, "RoHS" products are suitable for use in specified lead-free processes. TI may reference these types of products as "Pb-Free".

RoHS Exempt: TI defines "RoHS Exempt" to mean products that contain lead but are compliant with EU RoHS pursuant to a specific EU RoHS exemption.

Green: TI defines "Green" to mean the content of Chlorine (Cl) and Bromine (Br) based flame retardants meet JS709B low halogen requirements of <=1000ppm threshold. Antimony trioxide based flame retardants must also meet the <=1000ppm threshold requirement.

(3) MSL, Peak Temp. - The Moisture Sensitivity Level rating according to the JEDEC industry standard classifications, and peak solder temperature.

(4) There may be additional marking, which relates to the logo, the lot trace code information, or the environmental category on the device.

(5) Multiple Device Markings will be inside parentheses. Only one Device Marking contained in parentheses and separated by a "~" will appear on a device. If a line is indented then it is a continuation of the previous line and the two combined represent the entire Device Marking for that device.

⁽⁶⁾ Lead/Ball Finish - Orderable Devices may have multiple material finish options. Finish options are separated by a vertical ruled line. Lead/Ball Finish values may wrap to two lines if the finish value exceeds the maximum column width.

Important Information and Disclaimer:The information provided on this page represents TI's knowledge and belief as of the date that it is provided. TI bases its knowledge and belief on information provided by third parties, and makes no representation or warranty as to the accuracy of such information. Efforts are underway to better integrate information from third parties. TI has taken and continues to take reasonable steps to provide representative and accurate information but may not have conducted destructive testing or chemical analysis on incoming materials and chemicals. TI and TI suppliers consider certain information to be proprietary, and thus CAS numbers and other limited information may not be available for release.

In no event shall TI's liability arising out of such information exceed the total purchase price of the TI part(s) at issue in this document sold by TI to Customer on an annual basis.

OTHER QUALIFIED VERSIONS OF BQ24081 :

- Automotive: [BQ24081-Q1](#)

NOTE: Qualified Version Definitions:

- Automotive - Q100 devices qualified for high-reliability automotive applications targeting zero defects

TAPE AND REEL INFORMATION

QUADRANT ASSIGNMENTS FOR PIN 1 ORIENTATION IN TAPE

*All dimensions are nominal

Device	Package Type	Package Drawing	Pins	SPQ	Reel Diameter (mm)	Reel Width W1 (mm)	A0 (mm)	B0 (mm)	K0 (mm)	P1 (mm)	W (mm)	Pin1 Quadrant
BQ24080DRCR	VSON	DRC	10	3000	330.0	12.4	3.3	3.3	1.1	8.0	12.0	Q2
BQ24080DRCT	VSON	DRC	10	250	180.0	12.5	3.3	3.3	1.1	8.0	12.0	Q2
BQ24081DRCR	VSON	DRC	10	3000	330.0	12.4	3.3	3.3	1.1	8.0	12.0	Q2
BQ24081DRCT	VSON	DRC	10	250	180.0	12.5	3.3	3.3	1.1	8.0	12.0	Q2

TAPE AND REEL BOX DIMENSIONS

*All dimensions are nominal

Device	Package Type	Package Drawing	Pins	SPQ	Length (mm)	Width (mm)	Height (mm)
BQ24080DRCR	VSON	DRC	10	3000	338.0	355.0	50.0
BQ24080DRCT	VSON	DRC	10	250	205.0	200.0	33.0
BQ24081DRCR	VSON	DRC	10	3000	338.0	355.0	50.0
BQ24081DRCT	VSON	DRC	10	250	338.0	355.0	50.0

GENERIC PACKAGE VIEW

DRC 10

VSON - 1 mm max height

PLASTIC SMALL OUTLINE - NO LEAD

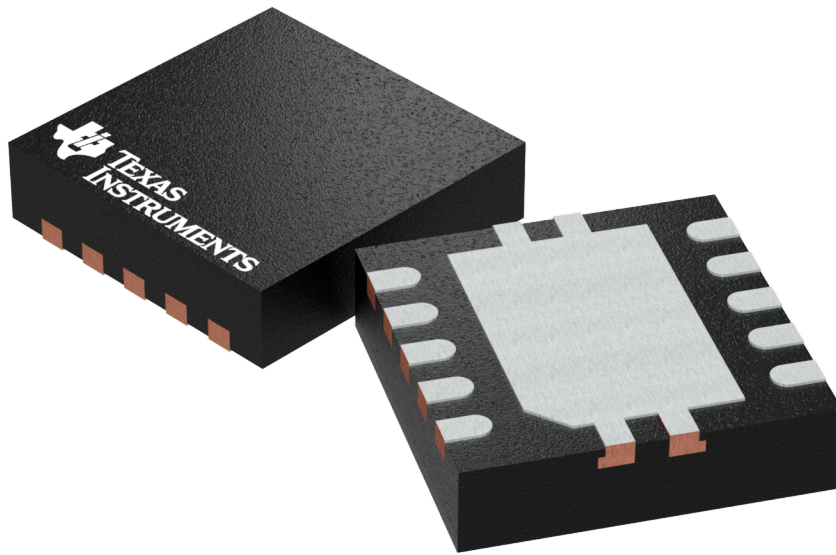

Images above are just a representation of the package family, actual package may vary.
Refer to the product data sheet for package details.

4204102-3/M

EXAMPLE BOARD LAYOUT

DRC0010J

VSON - 1 mm max height

PLASTIC SMALL OUTLINE - NO LEAD



LAND PATTERN EXAMPLE
EXPOSED METAL SHOWN
SCALE:20X

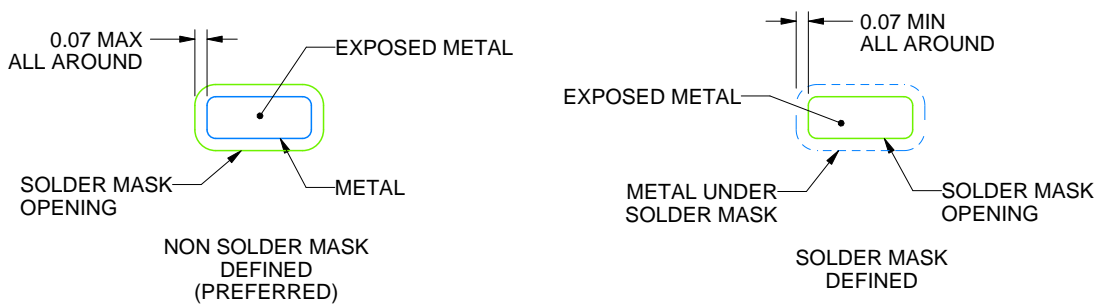

SOLDER MASK DETAILS

4218878/B 07/2018

NOTES: (continued)

4. This package is designed to be soldered to a thermal pad on the board. For more information, see Texas Instruments literature number SLUA271 (www.ti.com/lit/sluea271).
5. Vias are optional depending on application, refer to device data sheet. If any vias are implemented, refer to their locations shown on this view. It is recommended that vias under paste be filled, plugged or tented.

IMPORTANT NOTICE

Texas Instruments Incorporated (TI) reserves the right to make corrections, enhancements, improvements and other changes to its semiconductor products and services per JESD46, latest issue, and to discontinue any product or service per JESD48, latest issue. Buyers should obtain the latest relevant information before placing orders and should verify that such information is current and complete.

TI's published terms of sale for semiconductor products (<http://www.ti.com/sc/docs/stdterms.htm>) apply to the sale of packaged integrated circuit products that TI has qualified and released to market. Additional terms may apply to the use or sale of other types of TI products and services.

Reproduction of significant portions of TI information in TI data sheets is permissible only if reproduction is without alteration and is accompanied by all associated warranties, conditions, limitations, and notices. TI is not responsible or liable for such reproduced documentation. Information of third parties may be subject to additional restrictions. Resale of TI products or services with statements different from or beyond the parameters stated by TI for that product or service voids all express and any implied warranties for the associated TI product or service and is an unfair and deceptive business practice. TI is not responsible or liable for any such statements.

Buyers and others who are developing systems that incorporate TI products (collectively, "Designers") understand and agree that Designers remain responsible for using their independent analysis, evaluation and judgment in designing their applications and that Designers have full and exclusive responsibility to assure the safety of Designers' applications and compliance of their applications (and of all TI products used in or for Designers' applications) with all applicable regulations, laws and other applicable requirements. Designer represents that, with respect to their applications, Designer has all the necessary expertise to create and implement safeguards that (1) anticipate dangerous consequences of failures, (2) monitor failures and their consequences, and (3) lessen the likelihood of failures that might cause harm and take appropriate actions. Designer agrees that prior to using or distributing any applications that include TI products, Designer will thoroughly test such applications and the functionality of such TI products as used in such applications.

TI's provision of technical, application or other design advice, quality characterization, reliability data or other services or information, including, but not limited to, reference designs and materials relating to evaluation modules, (collectively, "TI Resources") are intended to assist designers who are developing applications that incorporate TI products; by downloading, accessing or using TI Resources in any way, Designer (individually or, if Designer is acting on behalf of a company, Designer's company) agrees to use any particular TI Resource solely for this purpose and subject to the terms of this Notice.

TI's provision of TI Resources does not expand or otherwise alter TI's applicable published warranties or warranty disclaimers for TI products, and no additional obligations or liabilities arise from TI providing such TI Resources. TI reserves the right to make corrections, enhancements, improvements and other changes to its TI Resources. TI has not conducted any testing other than that specifically described in the published documentation for a particular TI Resource.

Designer is authorized to use, copy and modify any individual TI Resource only in connection with the development of applications that include the TI product(s) identified in such TI Resource. NO OTHER LICENSE, EXPRESS OR IMPLIED, BY ESTOPPEL OR OTHERWISE TO ANY OTHER TI INTELLECTUAL PROPERTY RIGHT, AND NO LICENSE TO ANY TECHNOLOGY OR INTELLECTUAL PROPERTY RIGHT OF TI OR ANY THIRD PARTY IS GRANTED HEREIN, including but not limited to any patent right, copyright, mask work right, or other intellectual property right relating to any combination, machine, or process in which TI products or services are used. Information regarding or referencing third-party products or services does not constitute a license to use such products or services, or a warranty or endorsement thereof. Use of TI Resources may require a license from a third party under the patents or other intellectual property of the third party, or a license from TI under the patents or other intellectual property of TI.

TI RESOURCES ARE PROVIDED "AS IS" AND WITH ALL FAULTS. TI DISCLAIMS ALL OTHER WARRANTIES OR REPRESENTATIONS, EXPRESS OR IMPLIED, REGARDING RESOURCES OR USE THEREOF, INCLUDING BUT NOT LIMITED TO ACCURACY OR COMPLETENESS, TITLE, ANY EPIDEMIC FAILURE WARRANTY AND ANY IMPLIED WARRANTIES OF MERCHANTABILITY, FITNESS FOR A PARTICULAR PURPOSE, AND NON-INFRINGEMENT OF ANY THIRD PARTY INTELLECTUAL PROPERTY RIGHTS. TI SHALL NOT BE LIABLE FOR AND SHALL NOT DEFEND OR INDEMNIFY DESIGNER AGAINST ANY CLAIM, INCLUDING BUT NOT LIMITED TO ANY INFRINGEMENT CLAIM THAT RELATES TO OR IS BASED ON ANY COMBINATION OF PRODUCTS EVEN IF DESCRIBED IN TI RESOURCES OR OTHERWISE. IN NO EVENT SHALL TI BE LIABLE FOR ANY ACTUAL, DIRECT, SPECIAL, COLLATERAL, INDIRECT, PUNITIVE, INCIDENTAL, CONSEQUENTIAL OR EXEMPLARY DAMAGES IN CONNECTION WITH OR ARISING OUT OF TI RESOURCES OR USE THEREOF, AND REGARDLESS OF WHETHER TI HAS BEEN ADVISED OF THE POSSIBILITY OF SUCH DAMAGES.

Unless TI has explicitly designated an individual product as meeting the requirements of a particular industry standard (e.g., ISO/TS 16949 and ISO 26262), TI is not responsible for any failure to meet such industry standard requirements.

Where TI specifically promotes products as facilitating functional safety or as compliant with industry functional safety standards, such products are intended to help enable customers to design and create their own applications that meet applicable functional safety standards and requirements. Using products in an application does not by itself establish any safety features in the application. Designers must ensure compliance with safety-related requirements and standards applicable to their applications. Designer may not use any TI products in life-critical medical equipment unless authorized officers of the parties have executed a special contract specifically governing such use. Life-critical medical equipment is medical equipment where failure of such equipment would cause serious bodily injury or death (e.g., life support, pacemakers, defibrillators, heart pumps, neurostimulators, and implantables). Such equipment includes, without limitation, all medical devices identified by the U.S. Food and Drug Administration as Class III devices and equivalent classifications outside the U.S.

TI may expressly designate certain products as completing a particular qualification (e.g., Q100, Military Grade, or Enhanced Product). Designers agree that it has the necessary expertise to select the product with the appropriate qualification designation for their applications and that proper product selection is at Designers' own risk. Designers are solely responsible for compliance with all legal and regulatory requirements in connection with such selection.

Designer will fully indemnify TI and its representatives against any damages, costs, losses, and/or liabilities arising out of Designer's non-compliance with the terms and provisions of this Notice.

Looking for pricing, stock, or lifecycle information?

Click below to explore more details on WIN SOURCE:

 [View BQ24081DRCT](#) on WIN SOURCE

 [Texas Instruments](#) Information

Optimize Your Supply Chain with WIN SOURCE Solutions

-  Global Sourcing Solution
-  Obsolete Management
-  Cost Control Management
-  Shortage Management
-  Alternative Solution
-  Excess Inventory Management