



**THE DATASHEET OF
BQ24055DSST**



bq2405x 1-A, Single-Cell Li-Ion and Li-Pol Battery Charger With Automatic Adaptor and USB Detection

1 Features

- Charging
 - 1% Charge Voltage Accuracy
 - 10% Charge Current Accuracy
 - Pin Selectable USB 100-mA and 500-mA Maximum Input Current Limit
 - Programmable Termination and Precharge Threshold
- Protection
 - 30-V Input Rating; With 6.6-V Input Overvoltage Protection
 - Input Voltage Dynamic Power Management
 - 125 °C Thermal Regulation; 150°C Thermal Shutdown Protection
 - OUT Short-Circuit Protection and ISET Short Detection
 - Operation Over JEITA Range Through Battery NTC - ½ Fast-Charge-Current at Cold, 4.06 V at Hot
 - Fixed 10-Hour Safety Timer
- System
 - Auto Input Source Detection (D+, D– Pins)
 - No Device Transceiver Required
 - USB Friendly
 - Automatic Termination and Timer Disable Mode (TTDM) for Absent Battery Pack With Thermistor
 - Status Indication – Charging/Done
 - Available in Small 2-mm × 2-mm or 2-mm × 3-mm Package

2 Applications

- Smart Phones
- PDAs
- MP3 Players
- Low-Power Handheld Devices

3 Description

The bq2405x series of devices are highly integrated Li-Ion and Li-Pol linear chargers devices targeted at space-limited portable applications. The devices operate from either a USB port or AC adaptor. The high-input voltage range with input overvoltage protection supports low-cost unregulated adapters.

The bq2405x has a single power output that charges the battery. A system load can be placed in parallel with the battery as long as the average system load does not keep the battery from charging fully during the 10-hour safety timer.

The battery is charged in three phases: conditioning, constant current, and constant voltage. In all charge phases, an internal control loop monitors the IC junction temperature and reduces the charge current if an internal temperature threshold is exceeded.

The charger power stage and charge current sense functions are fully integrated. The charger function has high accuracy current and voltage regulation loops, charge status display, and charge termination. The precharge current and termination current threshold are programmed through an external resistor. The fast charge current value is also programmable through an external resistor.

Device Information⁽¹⁾

PART NUMBER	PACKAGE	BODY SIZE (NOM)
bq24050	WSON (10)	2.00 mm × 2.00 mm
bq24052		
bq24055	WSON (12)	2.00 mm × 3.00 mm

(1) For all available packages, see the orderable addendum at the end of the datasheet.

Simplified Circuit

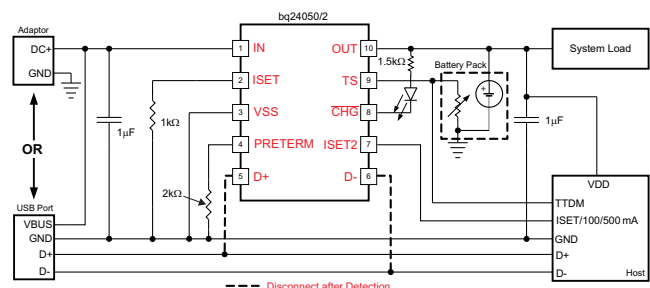

Table of Contents

1 Features	1	7.4 Device Functional Modes	25
2 Applications	1	7.5 Programming	25
3 Description	1	8 Application and Implementation	26
4 Revision History	2	8.1 Application Information	26
5 Pin Configuration and Functions	3	8.2 Typical Applications	26
6 Specifications	4	9 Power Supply Recommendations	30
6.1 Absolute Maximum Ratings	4	10 Layout	31
6.2 Handling Ratings	4	10.1 Layout Guidelines	31
6.3 Recommended Operating Conditions	4	10.2 Layout Example	31
6.4 Thermal Information	5	10.3 Thermal Considerations	32
6.5 Electrical Characteristics	5	11 Device and Documentation Support	33
6.6 Timing Requirements	9	11.1 Documentation Support	33
6.7 Switching Characteristics	9	11.2 Related Links	33
6.8 Typical Characteristics	10	11.3 Trademarks	33
7 Detailed Description	14	11.4 Electrostatic Discharge Caution	33
7.1 Overview	14	11.5 Glossary	33
7.2 Functional Block Diagram	15	12 Mechanical, Packaging, and Orderable Information	33
7.3 Feature Description	16		

4 Revision History

NOTE: Page numbers for previous revisions may differ from page numbers in the current version.

Changes from Revision B (June 2012) to Revision C	Page
<ul style="list-style-type: none"> Added <i>Handling Rating</i> table, <i>Feature Description</i> section, <i>Device Functional Modes</i>, <i>Application and Implementation</i> section, <i>Power Supply Recommendations</i> section, <i>Layout</i> section, <i>Device and Documentation Support</i> section, and <i>Mechanical, Packaging, and Orderable Information</i> section 	1

Changes from Revision A (September 2009) to Revision B	Page
<ul style="list-style-type: none"> Changed all occurrences of Li-Ion To: Li-Ion and Li-Pol 	1

Changes from Original (August 2009) to Revision A	Page
<ul style="list-style-type: none"> Changed the status of the devices From: Product Preview To: Production Data 	1

5 Pin Configuration and Functions

DSQ Package
10-Pin WSON With Exposed Thermal Pad
bq24050/bq24052 Top View

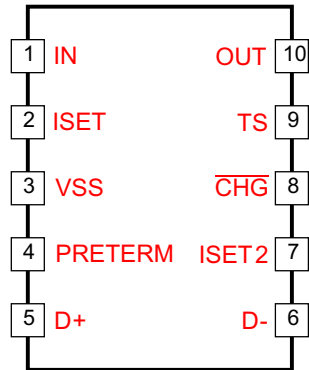

DSS Package
12-Pin WSON With Exposed Thermal Pad
bq24055 Top View

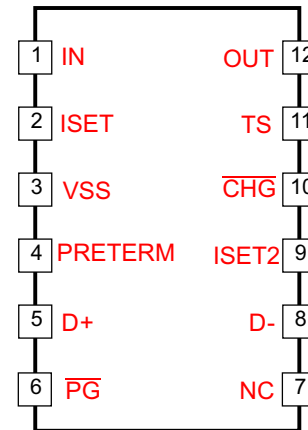

NOTE: NC - No internal connection

Pin Functions

NAME	PIN		I/O	DESCRIPTION
	NO.			
	bq24050/2	bq24055		
$\overline{\text{CHG}}$	8	10	O	Low (FET on) indicates charging and Open Drain (FET off) indicates no Charging or Charge complete.
D+	5	5	I	USB port D+ input connection
D-	6	8	I	USB port D- input connection
IN	1	1	I	Input power, connected to external DC supply (AC adapter or USB port). Expected range of bypass capacitors 1 μF to 10 μF , connect from IN to V_{SS} .
ISET	2	2	I	Programs the Fast-charge current setting. External resistor from ISET to VSS defines fast charge current value. Range is 52.3k (10 mA) to 540 Ω (1.0 A).
ISET2	7	9	I	Programming the Input/Output Current Limit for the USB or Adaptor source: High = 500 mA max, Low = ISET, FLOAT = 100 mA max. D+D- Detection initially sets the charge threshold and requires ISET2 to change states to take control.
NC	–	7	NA	Do not make connection to this pin (internal use) – Do not route through this pin
OUT	10	12	O	Battery Connection. System Load may be connected. Average load should not be excessive, allowing battery to charge within the 10-hour safety timer window. Expected range of bypass capacitors 1 μF to 10 μF .
$\overline{\text{PG}}$	–	6	O	Low (FET on) indicates the input voltage is above UVLO and the OUT (battery) voltage and less than V_{OVP}
PRE-TERM	4	4	I	Programs the Current Termination Threshold (5 to 50% of I_{out} which is set by ISET) and Sets the Precharge Current to twice the Termination Current Level. Expected range of programming resistor is 1k to 10 k Ω (2k: $I_{\text{OUT}}/10$ for term; $I_{\text{OUT}}/5$ for precharge)
TS	9 ⁽¹⁾	11	I	Temperature sense pin connected to '50/55 –10k at 25C NTC thermistor, '52 – 100k NTC at 25°C, in the battery pack. Floating TS Pin or pulling High puts part in TTDM and disable TS monitoring, Timers and Termination. Pulling pin Low disables the IC (CE function). If NTC sensing is not needed, connect this pin to VSS through an external '50/55-10-k Ω /'52-100-k Ω resistor. A '50/55-250-k Ω /'52-880-k Ω from TS to ground will prevent IC entering TTDM when battery with thermistor is removed.
VSS	3	3	–	Ground terminal

(1) Spins have different pin definitions

Pin Functions (continued)

PIN		I/O	DESCRIPTION	
NAME	NO.			
	bq24050/2	bq24055		
Thermal Pad and Package	Pad 2x2mm ²	Pad 2x3mm ²	–	There is an internal electrical connection between the exposed thermal pad and the VSS pin of the device. The thermal pad must be connected to the same potential as the VSS pin on the printed circuit board. Do not use the thermal pad as the primary ground input for the device. VSS pin must be connected to ground at all times.

6 Specifications

6.1 Absolute Maximum Ratings⁽¹⁾

over operating free-air temperature range (unless otherwise noted)

		MIN	MAX	UNIT
Input Voltage	IN (with respect to VSS)	–0.3	30	V
	OUT (with respect to VSS)	–0.3	7	V
	PRE-TERM, ISET, ISET2, TS, $\overline{\text{CHG}}$, $\overline{\text{PG}}$, D+, D–, (with respect to VSS)	–0.3	7	V
Input Current	IN		1.25	A
Output Current (Continuous)	OUT		1.25	A
Output Sink Current	$\overline{\text{CHG}}$		15	mA
Junction temperature, T _J		–40	150	°C

- (1) Stresses beyond those listed under *Absolute Maximum Ratings* may cause permanent damage to the device. These are stress ratings only, and functional operation of the device at these or any other conditions beyond those indicated under *Recommended Operating Conditions* is not implied. Exposure to absolute-maximum-rated conditions for extended periods may affect device reliability. All voltage values are with respect to the network ground terminal unless otherwise noted.

6.2 Handling Ratings

		MIN	MAX	UNIT
T _{stg}	Storage temperature range	–65	150	°C
V _(ESD)	Electrostatic discharge	Human body model (HBM), per ANSI/ESDA/JEDEC JS-001, all pins ⁽¹⁾	3000	V
		Charged device model (CDM), per JEDEC specification JESD22-C101, all pins ⁽²⁾	1500	

- (1) JEDEC document JEP155 states that 500-V HBM allows safe manufacturing with a standard ESD control process.
 (2) JEDEC document JEP157 states that 250-V CDM allows safe manufacturing with a standard ESD control process.

6.3 Recommended Operating Conditions⁽¹⁾

		MIN	NOM	UNIT
V _{IN}	IN voltage range	3.5	28	V
	IN operating voltage range, Restricted by V _{DPM} and V _{OVP}	4.45	6.45	V
I _{IN}	Input current, IN pin		1.0	A
I _{OUT}	Current, OUT pin		1.0	A
T _J	Junction temperature	0	125	°C
R _{PRE-TERM}	Programs precharge and termination current thresholds	1	10	kΩ
R _{ISET}	Fast-charge current programming resistor	0.540	52.3	kΩ
R _{TS}	10k NTC thermistor range without entering TTDM, bq24050/55	1.66	258	kΩ
	100k NTC thermistor range without entering TTDM, bq24052	24	885	kΩ

- (1) Operation with V_{IN} less than 4.5 V or in drop-out may result in reduced performance.

6.4 Thermal Information

THERMAL METRIC ⁽¹⁾		bq24050 bq24052	bq24055	UNIT
		DSQ	DSS	
		10 PINS	12 PINS	
R _{θJA}	Junction-to-ambient thermal resistance	63.5	61.8	°C/W
R _{θJC(top)}	Junction-to-case (top) thermal resistance	79.5	70.9	
R _{θJB}	Junction-to-board thermal resistance	33.9	25.7	
Ψ _{JT}	Junction-to-top characterization parameter	7.8	1.9	
Ψ _{JB}	Junction-to-board characterization parameter	34.3	25.7	
R _{θJC(bot)}	Junction-to-case (bottom) thermal resistance	7.5	7.2	

(1) For more information about traditional and new thermal metrics, see the *IC Package Thermal Metrics* application report, [SPRA953](#).

6.5 Electrical Characteristics

Over junction temperature range 0°C ≤ T_J ≤ 125°C and recommended supply voltage (unless otherwise noted)

PARAMETER		TEST CONDITIONS	MIN	TYP	MAX	UNIT
INPUT						
UVLO	Undervoltage lock-out Exit	V _{IN} : 0V → 4V Update based on sim/char	3.15	3.3	3.45	V
V _{HYS_UVLO}	Hysteresis on V _{UVLO_RISE} falling	V _{IN} : 4V → 0V, V _{UVLO_FALL} = V _{UVLO_RISE} - V _{HYS_UVLO}	175	230	280	mV
V _{IN-DT}	Input power good detection threshold is V _{OUT} + V _{IN-DT}	(Input power good if V _{IN} > V _{OUT} + V _{IN-DT}); V _{OUT} = 3.6V, V _{IN} : 3.5V → 4V	30	80	145	mV
V _{HYS-INDT}	Hysteresis on V _{IN-DT} falling	V _{OUT} = 3.6V, V _{IN} : 4V → 3.5V		31		mV
V _{OVP}	Input overvoltage protection threshold	V _{IN} : 5V → 7V (50/52/55)	6.5	6.65	6.8	V
V _{HYS-OVP}	Hysteresis on OVP	V _{IN} : 11V → 5V		95		mV
V _{IN-DPM}	USB/Adaptor low input voltage protection. Restricts I _{out} at V _{IN-DPM}	Feature active in USB mode; Limit Input Source Current to 50mA; V _{OUT} =3.5V; R _{ISET} = 825Ω	4.34	4.4	4.46	V
		Feature active in Adaptor mode; Limit Input Source Current to 50mA; V _{OUT} =3.5V; R _{ISET} = 825Ω	4.24	4.3	4.36	
I _{IN-USB-CL}	USB input I-Limit 100 mA	ISET2 = Float; R _{ISET} = 825Ω	85	92	100	mA
	USB input I-Limit 500 mA	ISET2 = High; R _{ISET} = 825Ω	430	462	500	
ISET SHORT CIRCUIT TEST						
R _{ISET_SHORT}	Highest Resistor value considered a fault (short). Monitored for I _{out} >90mA	Riset: 600Ω → 250Ω, I _{out} latches off. Cycle power to Reset. USB100 mode.	280		500	Ω
I _{OUT_CL}	Maximum OUT current limit Regulation (Clamp)	V _{IN} = 5V, V _{OUT} = 3.6V, V _{ISET2} = Low, Riset: 600Ω → 250Ω, I _{out} latches off after t _{DGL-SHORT}	1.05		1.4	A
BATTERY SHORT PROTECTION						
V _{OUT(SC)}	OUT pin short-circuit detection threshold/ precharge threshold	V _{OUT} : 3V → 0.5V, no deglitch	0.75	0.8	0.85	V
V _{OUT(SC-HYS)}	OUT pin Short hysteresis	Recovery ≥ V _{OUT(SC)} + V _{OUT(SC-HYS)} ; Rising, no Deglitch		77		mV
I _{OUT(SC)}	Source current to OUT pin during short-circuit detection		10	15	20	mA
QUIESCENT CURRENT						
I _{OUT(PDWN)}	Battery current into OUT pin	V _{IN} = 0V			1	μA
I _{OUT(DONE)}	OUT pin current, charging terminated	V _{IN} = 6V, V _{OUT} > V _{OUT(REG)}			6	
I _{IN(STDBY)}	Standby current into IN pin	TS = LO, V _{IN} ≤ 6V			125	μA
I _{CC}	Active supply current, IN pin	TS = open, V _{IN} = 6V, TTDM – no load on OUT pin, V _{OUT} > V _{OUT(REG)} , IC enabled		0.8	1	mA
BATTERY CHARGER FAST-CHARGE						
V _{OUT(REG)}	Battery regulation voltage	V _{IN} = 5.5V, I _{OUT} = 25mA, V _{TS-45°C} ≤ V _{TS} ≤ V _{TS-0°C}	4.16	4.20	4.23	V
V _{O_HT(REG)}	Battery hot regulation Voltage	V _{IN} = 5.5V, I _{OUT} = 25mA, V _{TS-60°C} ≤ V _{TS} ≤ V _{TS-45°C}	4.02	4.06	4.1	V
I _{OUT(RANGE)}	Programmed Output "fast charge" current range	V _{OUT(REG)} > V _{OUT} > V _{LOWV} , V _{IN} = 5V, ISET2=Lo, R _{ISET} = 675 to 10.8kΩ	10		800	mA

Electrical Characteristics (continued)

 Over junction temperature range $0^{\circ}\text{C} \leq T_J \leq 125^{\circ}\text{C}$ and recommended supply voltage (unless otherwise noted)

PARAMETER		TEST CONDITIONS	MIN	TYP	MAX	UNIT
$V_{\text{DO(IN-OUT)}}$	Drop-Out, $V_{\text{IN}} - V_{\text{OUT}}$	Adjust V_{IN} down until $I_{\text{OUT}} = 0.5\text{A}$, $V_{\text{OUT}} = 4.15\text{V}$, $R_{\text{ISET}} = 675\ \Omega$, $\text{ISET2} = \text{Lo}$ (Adaptor Mode); $T_J \leq 100^{\circ}\text{C}$		325	500	mV
I_{OUT}	Output "fast charge" formula	$V_{\text{OUT(REG)}} > V_{\text{OUT}} > V_{\text{LOWV}}$, $V_{\text{IN}} = 5\text{V}$, $\text{ISET2} = \text{Lo}$		$K_{\text{ISET}}/R_{\text{ISET}}$		A
K_{ISET}	Fast charge current factor	$R_{\text{ISET}} = K_{\text{ISET}}/I_{\text{OUT}}$ $50 < I_{\text{OUT}} < 1.0\text{A}$	510	540	570	A Ω
		$R_{\text{ISET}} = K_{\text{ISET}}/I_{\text{OUT}}$ $25 < I_{\text{OUT}} < 50\text{mA}$	480	527	600	
		$R_{\text{ISET}} = K_{\text{ISET}}/I_{\text{OUT}}$ $10 < I_{\text{OUT}} < 25\text{mA}$	350	520	680	
PRECHARGE – SET BY PRE-TERM PIN						
V_{LOWV}	Precharge to fast-charge transition threshold		2.4	2.5	2.6	V
$t_{\text{DGL1(LOWV)}}$	Deglintch time on precharge to fast-charge transition			70		μs
$I_{\text{PRE-TERM}}$	Refer to the Termination Section					
$\%_{\text{PRECHG}}$	Precharge Current Level, Default Setting	$V_{\text{OUT}} < V_{\text{LOWV}}$; $R_{\text{PRE-TERM}} = \text{High Z}$ ($\geq 13\text{k}\Omega$); $R_{\text{ISET}} = 1\text{k}$	18	20	22	$\%I_{\text{OUT-CC}}$
	Precharge current formula	$R_{\text{PRE-TERM}} = K_{\text{PRE-CHG}} (\Omega/\%) \times \%_{\text{PRE-CHG}} (\%)$		$R_{\text{PRE-TERM}}/K_{\text{PRE-CHG}}$		
$K_{\text{PRE-CHG}}$	% Precharge Factor	$V_{\text{OUT}} < V_{\text{LOWV}}$, $V_{\text{IN}} = 5\text{V}$, $R_{\text{PRE-TERM}} = 2\text{k}$ to $10\text{k}\Omega$; $R_{\text{ISET}} = 1080\Omega$, $R_{\text{PRE-TERM}} = K_{\text{PRE-CHG}} \times \%I_{\text{FAST-CHG}}$, where $\%I_{\text{FAST-CHG}}$ is 20 to 100%	90	100	110	$\Omega/\%$
		$V_{\text{OUT}} < V_{\text{LOWV}}$, $V_{\text{IN}} = 5\text{V}$, $R_{\text{PRE-TERM}} = 1\text{k}$ to $2\text{k}\Omega$; $R_{\text{ISET}} = 1080\Omega$, $R_{\text{PRE-TERM}} = K_{\text{PRE-CHG}} \times \%I_{\text{FAST-CHG}}$, where $\%I_{\text{FAST-CHG}}$ is 10% to 20%	84	100	117	$\Omega/\%$
TERMINATION – SET BY PRE-TERM PIN						
$\%_{\text{TERM}}$	Termination Current Threshold, Default Setting	$V_{\text{OUT}} > V_{\text{RCH}}$; $R_{\text{PRE-TERM}} = \text{High Z}$ ($\geq 13\text{k}\Omega$); $R_{\text{ISET}} = 1\text{k}$	9	10	11	$\%I_{\text{OUT-CC}}$
	Termination Current Threshold Formula	$R_{\text{PRE-TERM}} = K_{\text{TERM}} (\Omega/\%) \times \%_{\text{TERM}} (\%)$		$R_{\text{PRE-TERM}}/K_{\text{TERM}}$		
K_{TERM}	% Term Factor	$V_{\text{OUT}} > V_{\text{RCH}}$, $V_{\text{IN}} = 5\text{V}$, $R_{\text{PRE-TERM}} = 2\text{k}$ to $10\text{k}\Omega$; $R_{\text{ISET}} = 750\Omega$; $K_{\text{TERM}} \times \%I_{\text{FAST-CHG}}$, where $\%I_{\text{FAST-CHG}}$ is 10 to 50%	182	200	216	$\Omega/\%$
		$V_{\text{OUT}} > V_{\text{RCH}}$, $V_{\text{IN}} = 5\text{V}$, $R_{\text{PRE-TERM}} = 1\text{k}$ to $2\text{k}\Omega$; $R_{\text{ISET}} = 750\Omega$; $K_{\text{TERM}} \times \%I_{\text{FAST-CHG}}$, where $\%I_{\text{FAST-CHG}}$ is 5 to 10%	174	199	224	
$I_{\text{PRE-TERM}}$	Current for programming the term. and precharge with resistor. $I_{\text{Term-Start}}$ is the initial PRE-TERM current.	$R_{\text{PRE-TERM}} = 2\text{k}$, $V_{\text{OUT}} = 4.15\text{V}$	71	75	81	μA
$\%_{\text{TERM}}$	Termination current formula			$R_{\text{TERM}}/K_{\text{TERM}}$		
$I_{\text{Term-Start}}$	Elevated PRE-TERM current for, $t_{\text{Term-Start}}$, during start of charge to prevent recharge of full battery,		80	85	92	μA
RECHARGE OR REFRESH						
V_{RCH}	Recharge detection threshold – Normal Temp	$V_{\text{IN}} = 5\text{V}$, $V_{\text{TS}} = 0.5\text{V}$, $V_{\text{OUT}}: 4.25\text{V} \rightarrow V_{\text{RCH}}$	$V_{\text{O(REG)}} - 0.120$	$V_{\text{O(REG)}} - 0.095$	$V_{\text{O(REG)}} - 0.070$	V
	Recharge detection threshold – Hot Temp	$V_{\text{IN}} = 5\text{V}$, $V_{\text{TS}} = 0.2\text{V}$, $V_{\text{OUT}}: 4.15\text{V} \rightarrow V_{\text{RCH}}$	$V_{\text{O-HT(REG)}} - 0.130$	$V_{\text{O-HT(REG)}} - 0.105$	$V_{\text{O-HT(REG)}} - 0.080$	V
BATTERY DETECT ROUTINE⁽¹⁾						
$V_{\text{REG-BD}}$	V_{OUT} Reduced regulation during battery detect	$V_{\text{IN}} = 5\text{V}$, $V_{\text{TS}} = 0.5\text{V}$, Battery Absent	$V_{\text{O(REG)}} - 0.450$	$V_{\text{O(REG)}} - 0.400$	$V_{\text{O(REG)}} - 0.350$	V
$I_{\text{BD-SINK}}$	Sink current during $V_{\text{REG-BD}}$		7		10	mA
$V_{\text{BD-HI}}$	High battery detection threshold	$V_{\text{IN}} = 5\text{V}$, $V_{\text{TS}} = 0.5\text{V}$, Battery Absent	$V_{\text{O(REG)}} - 0.150$	$V_{\text{O(REG)}} - 0.100$	$V_{\text{O(REG)}} - 0.050$	V
$V_{\text{BD-LO}}$	Low battery detection threshold	$V_{\text{IN}} = 5\text{V}$, $V_{\text{TS}} = 0.5\text{V}$, Battery Absent	$V_{\text{REG-BD}} + 0.050$	$V_{\text{REG-BD}} + 0.100$	$V_{\text{REG-BD}} + 0.150$	V
BATTERY-PACK NTC MONITOR⁽²⁾						
$I_{\text{NTC-10k}}$	NTC bias current; 10k NTC thermistor, bq24050/5	$V_{\text{TS}} = 0.3\text{V}$	48	50	52	μA

 (1) In Hot Mode $V_{\text{O(REG)}}$ becomes $V_{\text{O-HT(REG)}}$

 (2) TS pin: bq24050/5: 10k NTC; bq24052: 100k NTC; See the [TS](#) Section for Thermistor Information

Electrical Characteristics (continued)

 Over junction temperature range $0^{\circ}\text{C} \leq T_J \leq 125^{\circ}\text{C}$ and recommended supply voltage (unless otherwise noted)

PARAMETER		TEST CONDITIONS	MIN	TYP	MAX	UNIT
$I_{\text{NTC-100k}}$	NTC bias current; 100k NTC thermistor, bq24052	$V_{\text{TS}} = 0.3\text{V}$	4.8	5	5.2	μA
$I_{\text{NTC-DIS-10k}}$	bq24050/5 bias current when Charging is disabled.	$V_{\text{TS}} = 0\text{V}$	27	30	34	μA
$I_{\text{NTC-DIS-100k}}$	bq24052 bias current when Charging is disabled.	$V_{\text{TS}} = 0\text{V}$	4.4	5	5.8	μA
$I_{\text{NTC-FLDBK-10k}}$	INTC is reduced prior to entering TTDM to keep cold thermistor from entering TTDM, bq24050/5	V_{TS} : Set to 1.525V	4	5	6.5	μA
$I_{\text{NTC-FLDBK-100k}}$	INTC is reduced prior to entering TTDM to keep cold thermistor from entering TTDM, bq24052	V_{TS} : Set to 1.525V	1.1	1.5	1.9	μA
$V_{\text{TTDM(TS)}}$	Termination and timer disable mode Threshold – Enter	V_{TS} : 0.5V \rightarrow 1.7V; Timer Held in Reset	1550	1600	1650	mV
$V_{\text{HYS-TTDM(TS)}}$	Hysteresis exiting TTDM	V_{TS} : 1.7V \rightarrow 0.5V; Timer Enabled		100		mV
$V_{\text{CLAMP(TS)}}$	TS maximum voltage clamp	V_{TS} = Open (Float)	1800	1950	2000	mV
$V_{\text{TS-FLDBK}}$	TS voltage where INTC is reduce to keep thermistor from entering TTDM	INTC adjustment (90 to 10%; 45 to 6.6 μA) takes place near this spec threshold. V_{TS} : 1.425V \rightarrow 1.525V		1475		mV
C_{TS}	Optional Capacitance – ESD			0.22		μF
$V_{\text{TS-0}^{\circ}\text{C}}$	bq2405x Low temperature CHG Pending	Low Temp Charging to Pending; V_{TS} : 1V \rightarrow 1.5V	1205	1230	1255	mV
$V_{\text{HYS-0}^{\circ}\text{C}}$	Hysteresis at 0°C	Charge pending to low temp charging; V_{TS} : 1.5V \rightarrow 1V		86		mV
$V_{\text{TS-10}^{\circ}\text{C}}$	Low temperature, half charge	Normal charging to low temp charging; V_{TS} : 0.5V \rightarrow 1V	765	790	815	mV
$V_{\text{HYS-10}^{\circ}\text{C}}$	Hysteresis at 10°C	Low temp charging to normal CHG; V_{TS} : 1V \rightarrow 0.5V		35		mV
$V_{\text{TS-45}^{\circ}\text{C}}$	High temperature at 4.1V	Normal charging to high temp CHG; V_{TS} : 0.5V \rightarrow 0.2V	263	278	293	mV
$V_{\text{HYS-45}^{\circ}\text{C}}$	Hysteresis at 45°C	High temp charging to normal CHG; V_{TS} : 0.2V \rightarrow 0.5V		10.7		mV
$V_{\text{TS-60}^{\circ}\text{C}}$	High temperature Disable	High temp charge to pending; V_{TS} : 0.2V \rightarrow 0.1V	170	178	186	mV
$V_{\text{HYS-60}^{\circ}\text{C}}$	Hysteresis at 60°C	Charge pending to high temp CHG; V_{TS} : 0.1V \rightarrow 0.2V		11.5		mV
$V_{\text{TS-EN-10k}}$	Charge Enable Threshold, (10k NTC)	V_{TS} : 0V \rightarrow 0.175V;	80	88	96	mV
$V_{\text{TS-DIS-HYS-10k}}$	HYS below $V_{\text{TS-EN-10k}}$ to Disable, (10k NTC)	V_{TS} : 0.125V \rightarrow 0V;		12		mV
$V_{\text{TS-EN-100k}}$	Charge Enable Threshold, (100k NTC)	V_{TS} : 0V \rightarrow 0.175V	140	150	160	mV
$V_{\text{TS-DIS-HYS-100k}}$	HYS below $V_{\text{TS-EN-100k}}$ to Disable, (100k NTC)	V_{TS} : 0.125V \rightarrow 0V;		50		mV
THERMAL REGULATION						
$T_{\text{J(REG)}}$	Temperature regulation limit			125		$^{\circ}\text{C}$
$T_{\text{J(OFF)}}$	Thermal shutdown temperature			155		$^{\circ}\text{C}$
$T_{\text{J(OFF-HYS)}}$	Thermal shutdown hysteresis			20		$^{\circ}\text{C}$
LOGIC LEVELS ON ISET2						
V_{IL}	Logic LOW input voltage	Sink more than 8 μA			0.4	V
V_{IH}	Logic HIGH input voltage	Source more than 8 μA	1.4			V
I_{IL}	Sink current required for LO		2		9	μA
I_{IH}	Source current required for HI		1.1		8	μA
V_{FLT}	ISET2 Float Voltage		650	900	1200	mV
D+/D- DETECTION – bq2405x						
$V_{\text{D+}}$	Bias at D+, during detection routine	Can source at least 200 μA	0.475	0.6	0.7	V
$I_{\text{D+}}$	Current Limit at D+ pin, during detection routine	$V_{\text{D+}} = 0\text{V}$			1.5	mA

Electrical Characteristics (continued)

 Over junction temperature range $0^{\circ}\text{C} \leq T_J \leq 125^{\circ}\text{C}$ and recommended supply voltage (unless otherwise noted)

PARAMETER		TEST CONDITIONS	MIN	TYP	MAX	UNIT
I_{D-}	Current Sink at D– pin, during detection routine	$V_{D-} = 0.5\text{V}$	50	100	150	μA
$I_{D+,LEAK}$	D+ leakage when not in detection mode	$V_{D+} = 5\text{V}$			1	μA
$I_{D-,LEAK}$	D– leakage when not in detection mode	$V_{D-} = 5\text{V}$			1	μA
$V_{DPDM,0.4V}$	D– Comparator Threshold Rising		0.35		0.45	V
$V_{DPDM,HYS,0.4V}$	D– Comparator Hysteresis			42		mV
$V_{DPDM,0.8V}$	D+/D– Comparator Threshold Rising		0.75		0.875	V
$V_{DPDM,HYS,0.8V}$	D+/D– Comparator Hysteresis			42		mV
LOGIC LEVELS ON $\overline{\text{CHG}}$ AND $\overline{\text{PG}}$						
V_{OL}	Output LOW voltage	$I_{SINK} = 5\text{mA}$			0.4	V
I_{lkg}	Leakage current into IC	$V_{\overline{\text{CHG}}} = 5\text{V}, V_{\overline{\text{PG}}} = 5\text{V}$			1	μA

6.6 Timing Requirements

		MIN	NOM	MAX	UNIT
PRECHARGE – SET BY PRETERM PIN					
$t_{DGL2(LOWV)}$	Deglitch time on fast-charge to precharge transition		32		ms
TERMINATION – SET BY PRE-TERM PIN					
$t_{DGL(TERM)}$	Deglitch time, termination detected		29		ms
$t_{Term-Start}$	Elevated termination threshold initially active for $t_{Term-Start}$		1.25		min
BATTERY-PACK NTC MONITOR⁽¹⁾					
$t_{DGL(TTDM)}$	Deglitch exit TTDM between states		57		ms
	Deglitch enter TTDM between states		8		μ s

(1) TS pin: bq24050/5: 10k NTC; bq24052: 100k NTC; See the [TS](#) Section for Thermistor Information

6.7 Switching Characteristics

over operating free-air temperature range (unless otherwise noted)

PARAMETER	TEST CONDITIONS	MIN	TYP	MAX	UNIT		
INPUT							
$t_{DGL(PG_PWR)}$	Deglitch time on exiting sleep.	Time measured from V_{IN} : 0V \rightarrow 5V 1 μ s rise-time to \overline{PG} = low, V_{OUT} = 3.6V		45	μ s		
$t_{DGL(PG_NO-PWR)}$	Deglitch time on $V_{HYS-INDT}$ power down. Same as entering sleep.	Time measured from V_{IN} : 5V \rightarrow 3.2V 1 μ s fall-time to \overline{PG} = High Z, V_{OUT} = 3.6V		29	ms		
$t_{DGL(OVP-SET)}$	Input overvoltage blanking time	V_{IN} : 5V \rightarrow 12V		113	μ s		
$t_{DGL(OVP-REC)}$	Deglitch time exiting OVP	Time measured from V_{IN} : 12V \rightarrow 5V 1 μ s fall-time to \overline{PG} = LO		30	μ s		
ISET SHORT CIRCUIT TEST							
t_{DGL_SHORT}	Deglitch time transition from ISET short to Iout disable	Clear fault by cycling IN or TS		1	ms		
RECHARGE OR REFRESH							
$t_{DGL1(RCH)}$	Deglitch time, recharge threshold detected	V_{IN} = 5V, V_{TS} = 0.5V, V_{OUT} : 4.25V \rightarrow 3.5V in 1 μ s; $t_{DGL1(RCH)}$ is time to ISET ramp		29	ms		
$t_{DGL2(RCH)}$	Deglitch time, recharge threshold detected in OUT-Detect Mode	V_{IN} = 5V, V_{TS} = 0.5V, V_{OUT} = 3.5V inserted; $t_{DGL2(RCH)}$ is time to ISET ramp		3.6	ms		
BATTERY DETECT ROUTINE⁽¹⁾							
$t_{DGL(HI/LOW_REG)}$	Regulation time at V_{REG} or V_{REG-BD}	V_{IN} = 5V, V_{TS} = 0.5V, Battery Absent		25	ms		
BATTERY CHARGING TIMERS AND FAULT TIMERS							
t_{PRECHG}	Precharge safety timer value	Restarts when entering precharge; Always enabled when in precharge.		1700	1940	2250	s
t_{MAXCH}	Charge safety timer value	Clears fault or resets at UVLO, TS (CE) disable, OUT Short, exiting LOWV and Refresh		34000	38800	45000	s
BATTERY-PACK NTC MONITOR⁽²⁾							
$t_{DGL(TS_10C)}$	Deglitch for TS thresholds: 10°C	Normal to Cold Operation: V_{TS} : 0.6V \rightarrow 1V		40		ms	
		Cold to Normal Operation: V_{TS} : 1.0V \rightarrow 0.6V		12		ms	
$t_{DGL(TS)}$	Deglitch for TS thresholds: 0/45/60C.	Battery charging		30		ms	
D+/D- DETECTION – bq2405x							
t_{DPDM}	DetectionTime from start of D+/D- detection to latched output	t = 0 at D- pulled-up > 0.5V or D+ pulled up externally, >0.8V		65		ms	

(1) In Hot Mode $V_{O(REG)}$ becomes $V_{O_HT(REG)}$

(2) TS pin: bq24050/5: 10k NTC; bq24052: 100k NTC; See the [TS](#) Section for Thermistor Information

6.8 Typical Characteristics

SETUP: bq24055 typical applications schematic; $V_{IN} = 5\text{ V}$, $V_{BAT} = 3.6\text{ V}$ (unless otherwise indicated)

$R_{ISET} = 1\text{ k}$; $I_{OUT_FAST_CHG} = 540\text{ mA}$; $R_{PAC_TERM} = 2\text{ k}$; $I_{OUT_PRE_CHG} = 108\text{ mA}$; $I_{OUT_TERM} = 54\text{ mA}$

6.8.1 Power Up, Down, OVP, Disable and Enable Waveforms

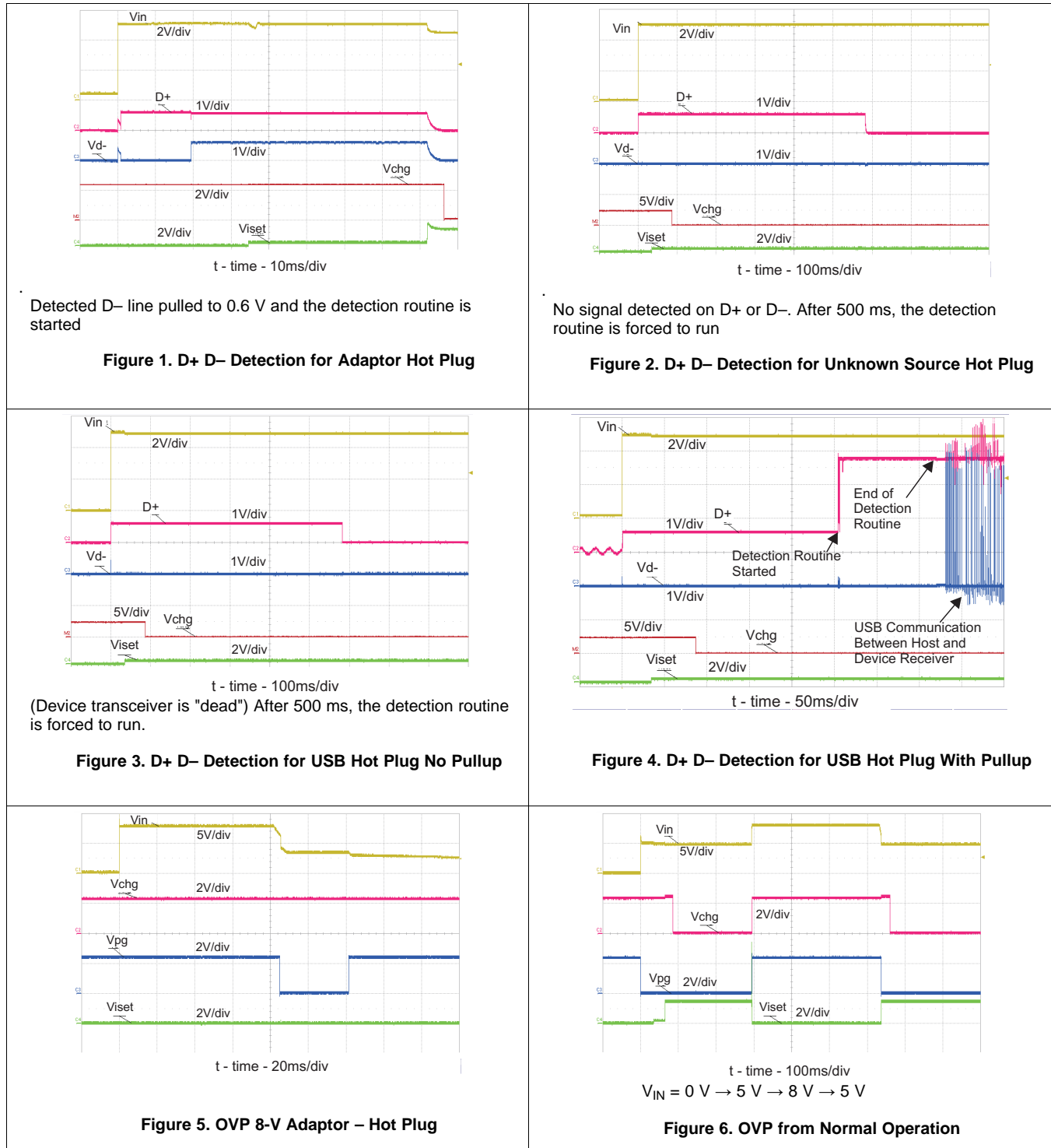

Power Up, Down, OVP, Disable and Enable Waveforms (continued)

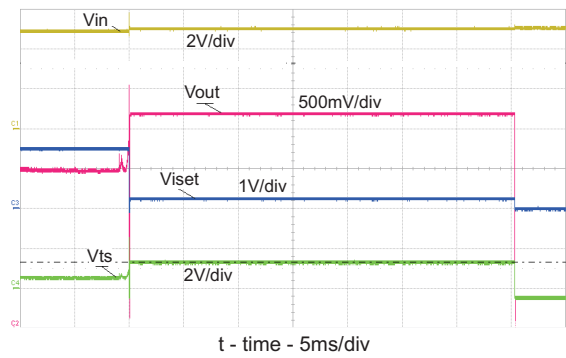

42-Ω Load

Figure 7. Battery Removal – GND Removed First

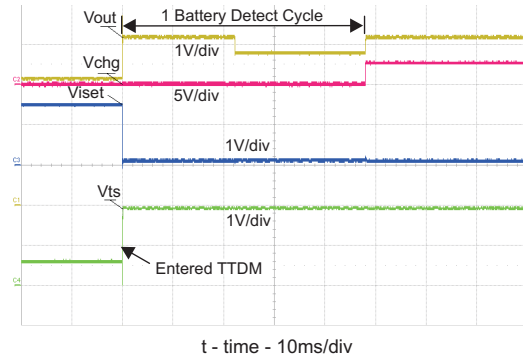

100-Ω Load

Figure 8. Battery Removal With OUT and TS Disconnect First

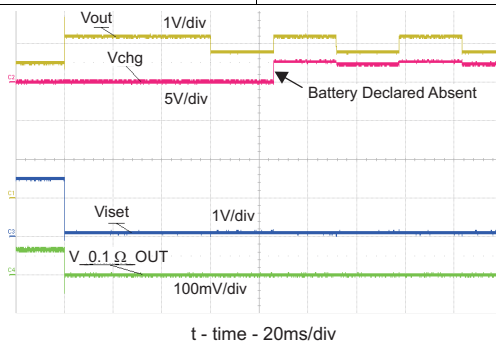

t - time - 20ms/div

Continuous battery detection when not in TTDM

Figure 9. Battery Removal With Fixed TS = 0.5 V

6.8.2 Protection Circuits Waveforms

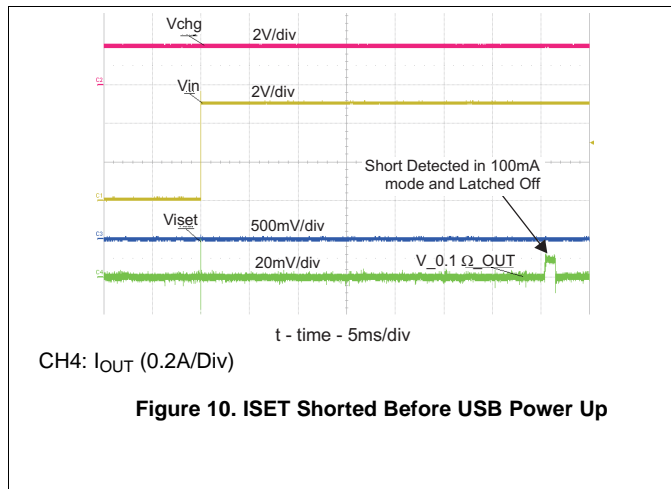

Figure 10. ISET Shorted Before USB Power Up

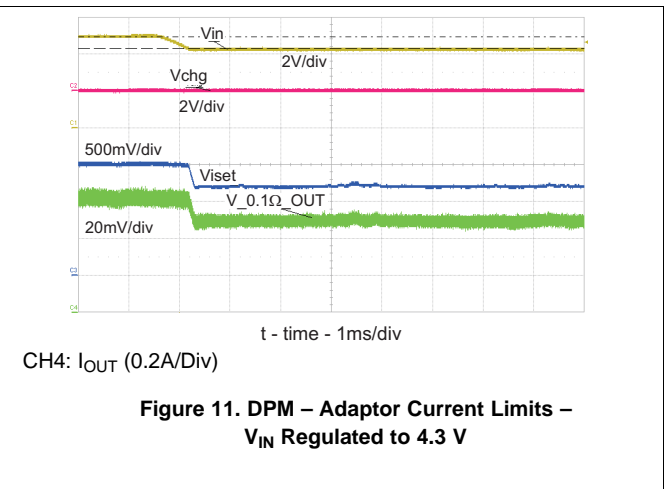

Figure 11. DPM – Adaptor Current Limits – V_{IN} Regulated to 4.3 V

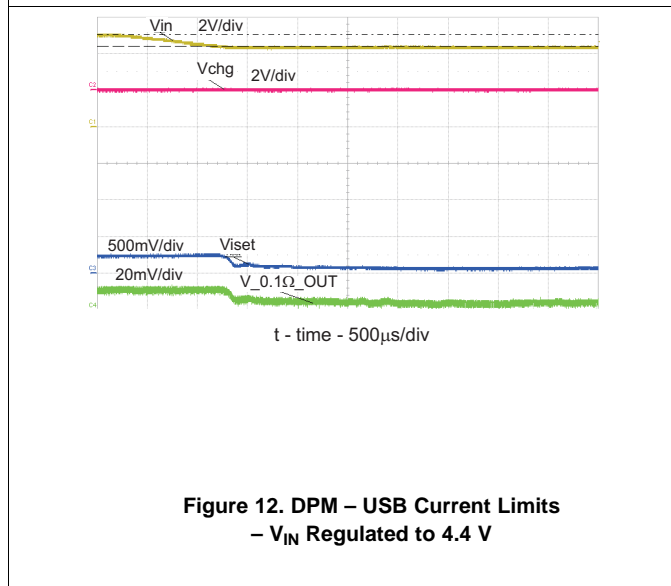
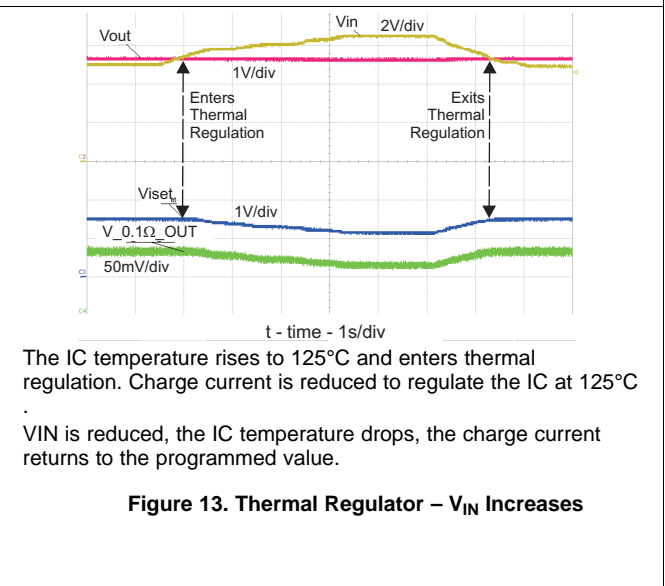

Figure 12. DPM – USB Current Limits – V_{IN} Regulated to 4.4 V



The IC temperature rises to 125°C and enters thermal regulation. Charge current is reduced to regulate the IC at 125°C. V_{IN} is reduced, the IC temperature drops, the charge current returns to the programmed value.

Figure 13. Thermal Regulator – V_{IN} Increases

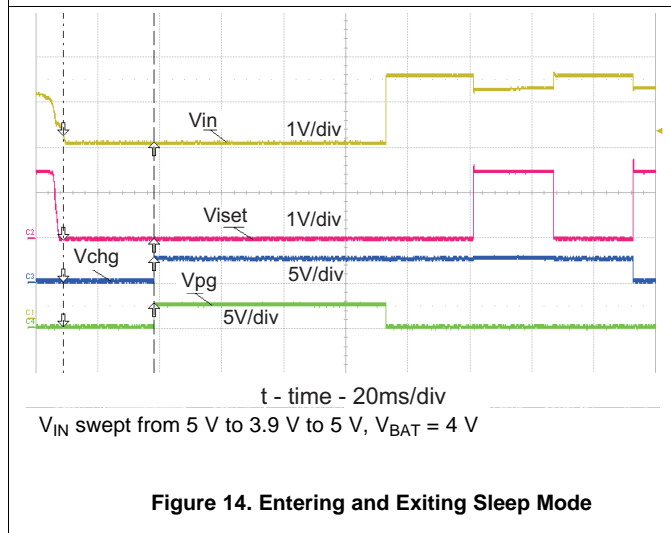

Figure 14. Entering and Exiting Sleep Mode

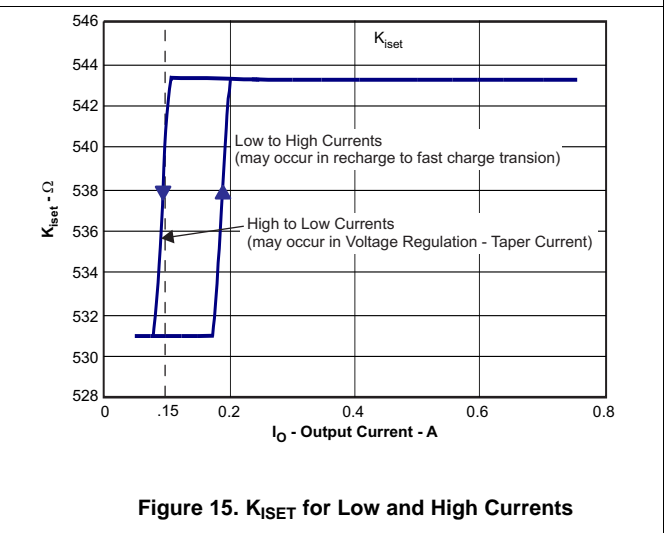

Figure 15. K_{ISET} for Low and High Currents

Protection Circuits Waveforms (continued)

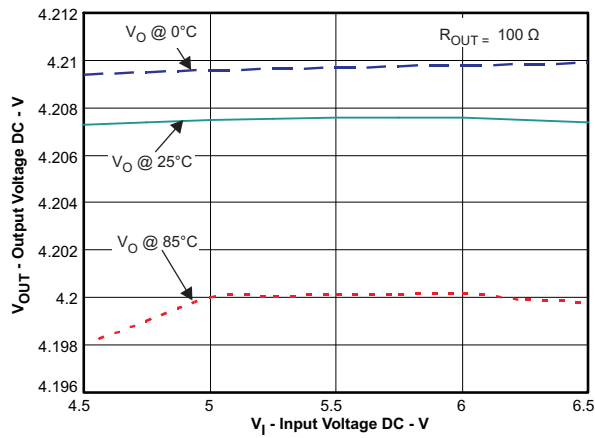

Figure 16. Line Regulation

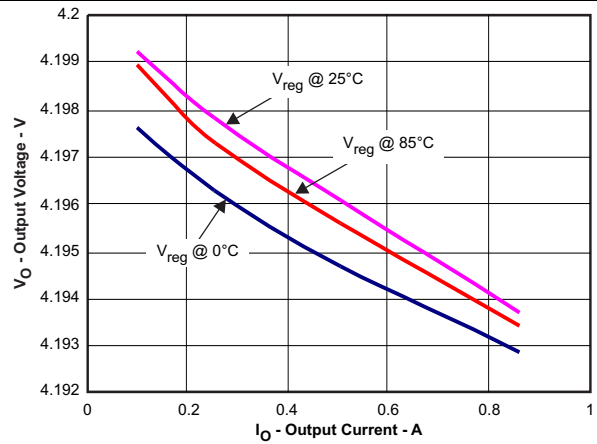

Figure 17. Load Regulation Overtemperature

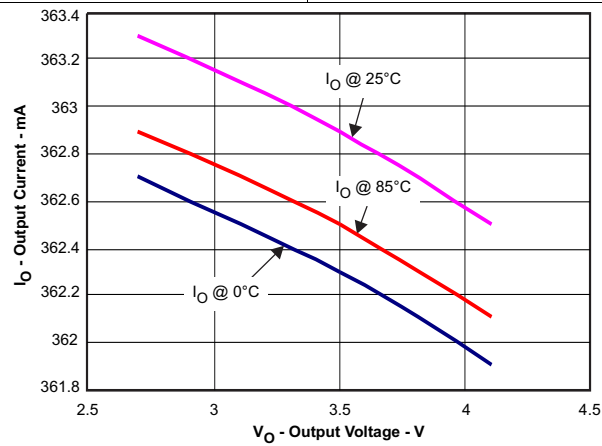

Figure 18. Current Regulation Overtemperature

7 Detailed Description

7.1 Overview

The bq2405x is a highly integrated family of 2-mm × 2-mm or 2-mm × 3-mm single-cell Li-Ion and Li-Pol chargers. The charger can be used to charge a battery, power a system or both. The charger has three phases of charging: precharge to recover a fully discharged battery, fast-charge constant current to supply the buck charge safely and voltage regulation to safely reach full capacity. The charger is flexible, allowing programming of the fast-charge current, precharge current and termination. This charger is designed to work with a USB connection or adaptor (DC out). The charger also checks to see if a battery is present.

The charger also comes with a full set of safety features: JEITA Temperature Standard, Overvoltage Protection, DPM-IN, Safety Timers, and ISET short protection. All of these features and more are described in detail below.

The charger is designed for a single power path from the input to the output to charge a single cell Li-Ion or Li-Pol battery pack. Upon application of a 5VDC power source the D+, D– detection routine is run to determine if the source is an Adaptor or a USB port. This feature is useful, when the battery is discharged (USB transceiver dead) or there is no transceiver, by early detection of an adaptor, thus allowing initial charging at the adaptor level. ISET and OUT short checks are performed in parallel with the detection routine to assure a proper charge cycle.

If the battery voltage is below the LOWV threshold, the battery is considered discharged and a preconditioning cycle begins. The amount of precharge current can be programmed using the PRE-TERM pin which programs a percent of fast charge current (10 to 100%) as the precharge current. This feature is useful when the system load is connected across the battery *stealing* the battery current. The precharge current can be set higher to account for the system loading while allowing the battery to be properly conditioned. The PRE-TERM pin is a dual-function pin which sets the precharge current level and the termination threshold level. The termination "current threshold" is always half of the precharge programmed current level.

Once the battery voltage has charged to the V_{LOWV} threshold, fast charge is initiated and the fast charge current is applied. The fast charge constant current is programmed using the ISET pin. The constant current provides the bulk of the charge. Power dissipation in the IC is greatest in fast charge with a lower battery voltage. If the IC reaches 125°C, the IC enters thermal regulation. Slow the timer clock by half and reduce the charge current as needed to keep the temperature from rising any further. [Figure 19](#) shows the charging profile with thermal regulation. Typically under normal operating conditions, the IC's junction temperature is less than 125°C and thermal regulation is not entered.

Once the cell has charged to the regulation voltage the voltage loop takes control and holds the battery at the regulation voltage until the current tapers to the termination threshold. The charge termination can be disabled if desired. The CHG pin is low (LED on) during the first charge cycle only and turns off once the charge termination threshold is reached, regardless if termination is enabled or disabled.

The TS pin monitors the voltage across the pack thermistor and implements the JEITA standard. This allows for reduced voltage regulation at hot temperatures and reduced charge currents at low temperatures. The TS pin incorporates a chip disable feature when pulled low and an Termination and Timer Disable Mode (TTDM) feature when left floating or pulled high.

7.2 Functional Block Diagram

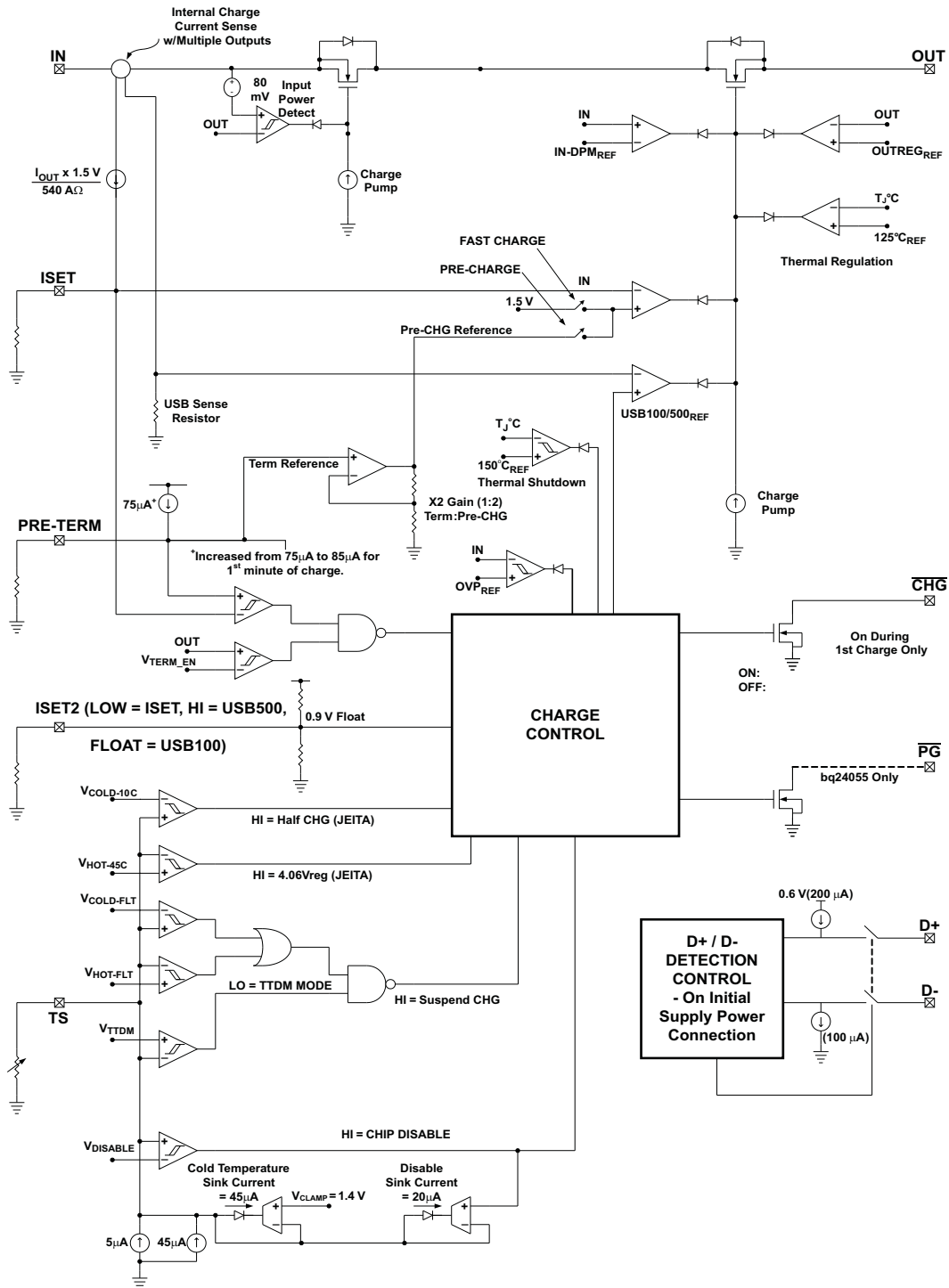

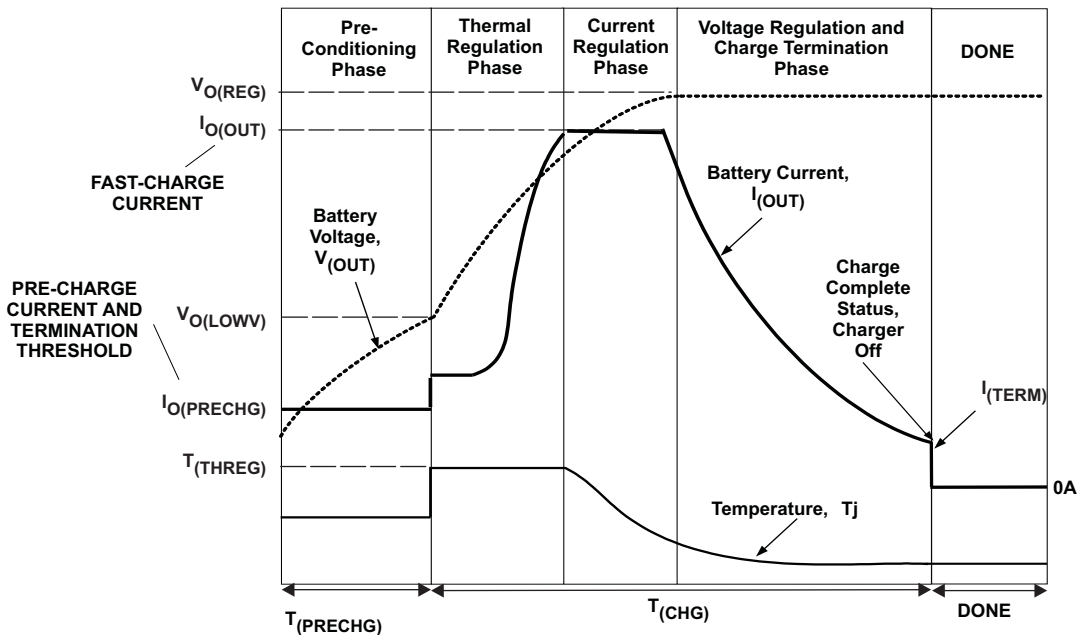
Functional Block Diagram (continued)

Figure 19. Charging Profile With Thermal Regulation
7.3 Feature Description
7.3.1 Power Down, or Undervoltage Lockout (UVLO):

The bq2405x family is in power down mode if the voltage of the IN pin is less than UVLO. The part is considered *dead* and all the pins are high impedance. Once the IN voltage rises above the UVLO threshold the IC enters Sleep Mode or Active mode depending on the voltage of the OUT pin (battery).

7.3.2 Power Up

The IC is alive after the IN voltage ramps above UVLO (see [Sleep Mode](#)), resets all logic and timers, and starts to perform the D+/D- detection along with many of the continuous monitoring routines. The D+/D- detection typically take less than 100 ms, but can take as long as 600 ms if there is no activity on the D+ or D- lines which indicates the device transceiver nor an adaptor is present. Typically the input voltage quickly rises through the UVLO and sleep states where the IC declares power good, starts the qualification charge at 100 mA, finishes the USB detection routine, sets the input current limit threshold base on the source detected (ISET=adaptor or 100mA=USB), starts the safety timer, and enables the CHG pin. See [Figure 21](#).

7.3.3 D+, D- Detection:

This detection is designed to give the charger advance notice that an adaptor or USB port is connect for the cases where the battery is discharged and device transceiver is not able to communicate with a USB host or there is not a device transceiver. If an adaptor is detected, then the charger can immediately start charging at the programmed ISET level. Without this early detection, the charger would have to default to the 100-mA input current level to make sure it was not over-loading a low power USB port. The detection method monitors the D+, D- communication lines looking for a short between the lines (Adaptor source connected) or pull-down resistors on D+, D- (USB source connected) to determine what source is connected (no USB communication takes place). If an adaptor source is detected then the charger will transition from the 100 mA startup level to the ISET programmed current level. If a USB port is detected, the input current limit will stay at the 100 mA level. If a different charge level is desired, than the one detected, the host has to change the state of the ISET2 pin (signals the internal logic to start using the ISET2 as the program pin) and then set to the desired state.

Feature Description (continued)

The D+ and D– pin connections inside the charger are disconnected within 100 ms of the D+ or D– lines being pulled high (start of detection), to minimize any interaction between the charger detection pins and the USB normal communications. If the device transceiver is able to communicate with the USB host, communication typically starts after 100 ms after the device has pulled the D+ or D– line high indicating it is “on line”, and by then the IC detection is complete and has been disconnected. The device host then may change the ISET2 level or disable the IC by pulling the TS pin low.

7.3.4 New Charge Cycle

A new charge cycle is started when a good power source is applied, performing a chip disable/enable (TS pin), exiting Termination and Timer Disable Mode (TTDM), detecting a battery insertion or the OUT voltage dropping below the VRCH threshold. The CHG pin is active low only during the first charge cycle, therefore exiting TTDM or a dropping below VRCH will not turn on the CHG pin FET, if the CHG pin is already high impedance.

Feature Description (continued)

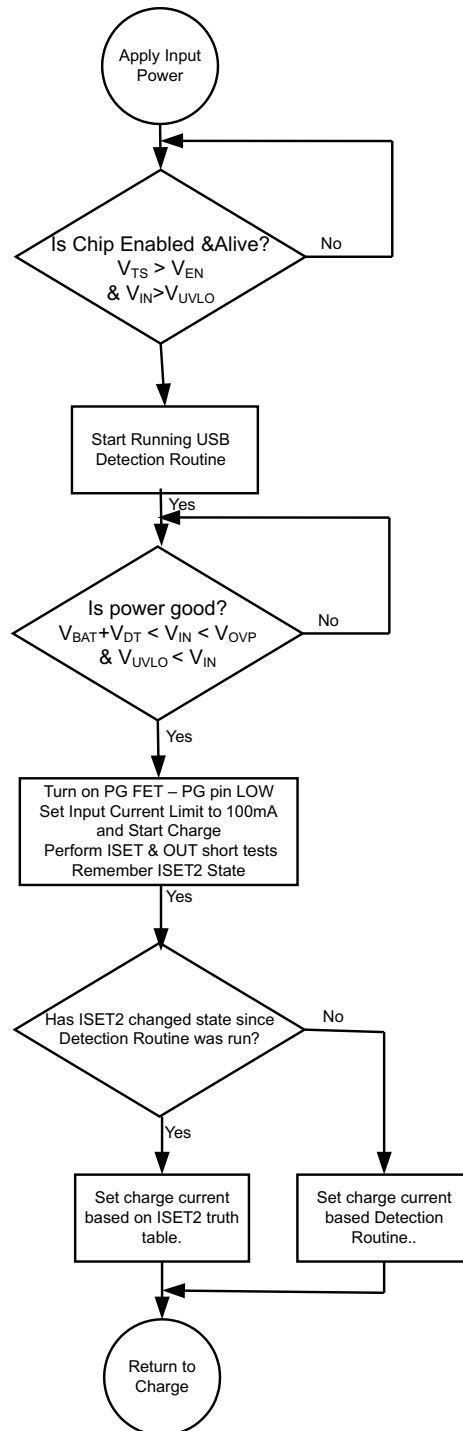

Figure 21. Power Up Flow Diagram

7.3.5 Overvoltage Protection (OVP) – Continuously Monitored

If the input source applies an overvoltage, the pass FET, if previously on, turns off after a deglitch, $t_{BLK(OVP)}$. The timer ends and the \overline{CHG} and \overline{PG} pin goes to a high impedance state. Once the overvoltage returns to a normal voltage, the \overline{PG} pin goes low, timer continues, charge continues and the \overline{CHG} pin goes low after a 25-ms deglitch. \overline{PG} pin is optional on some packages.

Feature Description (continued)

7.3.6 Power Good Indication (\overline{PG})

After application of a 5 V source, the input voltage rises above the UVLO and sleep thresholds ($V_{IN} > V_{OUT} + V_{DT}$), but is less than OVP ($V_{IN} < V_{OVP}$), then the \overline{PG} FET turns on and provides a low impedance path to ground. See [Figure 5](#), [Figure 6](#), and [Figure 14](#).

7.3.7 CHG Pin Indication

The charge pin has an internal open drain FET which is on (pulls down to V_{SS}) during the first charge only (independent of TTDM) and is turned off once the battery reaches voltage regulation and the charge current tapers to the termination threshold set by the PRE-TERM resistor.

The charge pin will be high impedance in sleep mode and OVP (if \overline{PG} is high impedance) and return to its previous state when the condition is removed.

Cycling input power, pulling the TS pin low and releasing or entering precharge mode will cause the \overline{CHG} pin to reset and is considered the start of a first charge.

7.3.8 \overline{CHG} and \overline{PG} LED Pullup Source

For host monitoring, a pullup resistor is used between the *STATUS* pin and the V_{CC} of the host and for a visual indication a resistor in series with an LED is connected between the *STATUS* pin and a power source. If the \overline{CHG} or \overline{PG} source can exceed 7 V, a 6.2-V Zener diode should be used to clamp the voltage. If the source is the OUT pin, note that as the battery changes voltage, the brightness of the LEDs vary.

CHARGING STATE	\overline{CHG} FET/LED
1st Charge	ON
Refresh Charge	OFF
OVP	
SLEEP	
TEMP FAULT	ON for 1st Charge

V_{IN} POWER GOOD STATE	\overline{PG} FET/LED
UVLO	OFF
SLEEP Mode	
OVP Mode	
Normal Input ($V_{OUT} + V_{DT} < V_{IN} < V_{OVP}$)	ON
PG is independent of chip disable (bq24055, $V_{TS} = 0V$)	

7.3.9 Input DPM Mode (V_{IN} -DPM or IN-DPM)

The IN-DPM feature is used to detect an input source voltage that is folding back (voltage dropping), reaching its current limit due to an excessive load. When the input voltage drops to the V_{IN-DPM} threshold the internal pass FET starts to reduce the current until there is no further drop in voltage at the input. This would prevent a source with voltage less than V_{IN-DPM} to power the out pin. This works well with current limited adaptors and USB ports as long as the nominal voltage is above 4.3 V and 4.4 V respectively. This is an added safety feature that helps protect the source from excessive loads.

7.3.10 OUT

The OUT pin of the charger provides current to the battery and to the system, if present. This IC can be used to charge the battery plus power the system, charge just the battery or just power the system (TTDM) assuming the loads do not exceed the available current. The OUT pin is a current limited source and is inherently protected against shorts. If the system load ever exceeds the output programmed current threshold, the output will be discharged unless there is sufficient capacitance or a charged battery present to supplement the excessive load.

7.3.11 ISET

An external resistor is used to Program the Output Current (10 mA to 1.0 A) and can be used as a current monitor.

$$R_{ISET} = K_{ISET} \div I_{OUT} \tag{1}$$

Where:

- I_{OUT} is the desired fast charge current;
- K_{ISET} is a gain factor found in the electrical specification

For greater accuracy at lower currents, part of the sense FET is disabled to give better resolution. Figure 15 shows the transition from low current to higher current. Going from higher currents to low currents, there is hysteresis and the transition occurs around 0.15 A.

The ISET resistor is short protected and will detect a resistance lower than $\approx 340 \Omega$. The detection requires at least 80 mA of output current. If a “short” is detected, then the IC will latch off and can only be reset by cycling the power. The OUT current is internally clamped to a maximum current between 1.05 A and 1.4 A and is independent of the ISET short detection circuitry, as shown in Figure 23. Also, see Figure 30 and Figure 10.

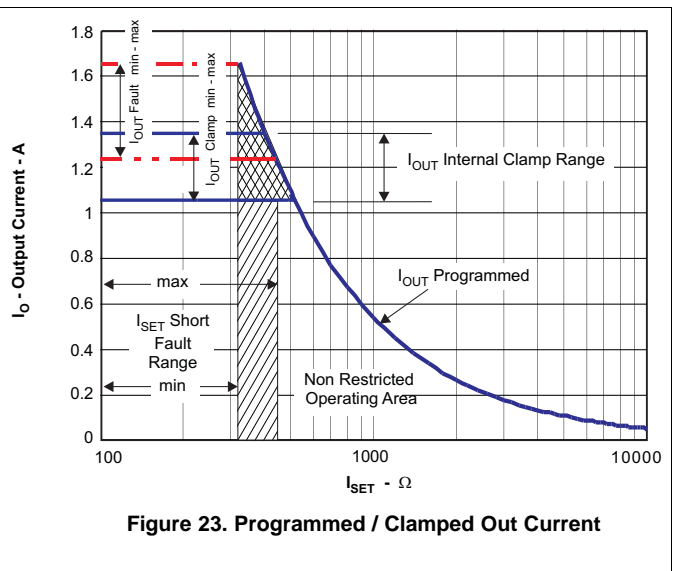
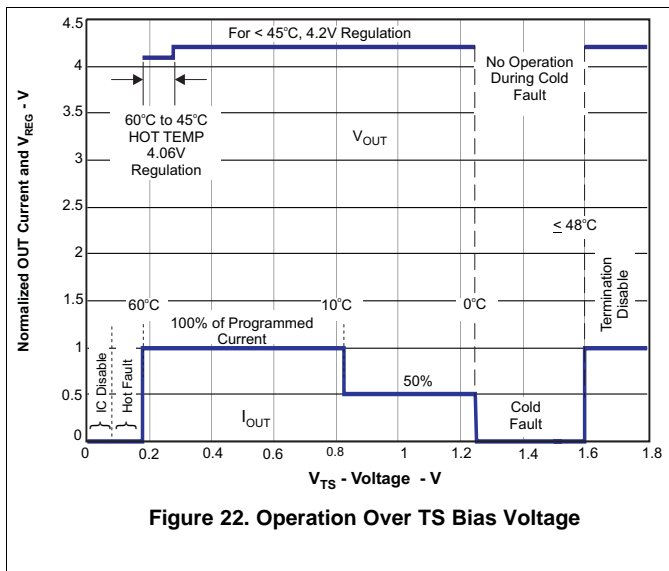

7.3.12 TS

The TS pin is designed to follow the new JEITA temperature standard for Li-Ion and Li-Pol batteries. There are now four thresholds, 60°C, 45°C, 10°C, and 0°C. Normal operation occurs from 10°C to 45°C. If between 0°C and 10°C the charge current level is cut in half and if between 45°C and 60°C the regulation voltage is reduced to 4.1 Vmax, see [Figure 22](#). The TS feature is implemented using an internal 50- μ A current source to bias the thermistor (bq24050/5 designed for use with a 10k NTC $\beta = 3370$ (SEMITEC 103AT-2 or Mitsubishi TH05-3H103F), and bq24052 with a 100k NTC $\beta = 3540$ (Mitsubishi TH05-36104F) or equivalent) connected from the TS pin to V_{SS}. If this feature is not needed, a fixed 10k can be placed between TS and V_{SS} to allow normal operation. This may be done if the host is monitoring the thermistor and then the host would determine when to pull the TS pin low to disable charge.

The TS pin has two additional features, when the TS pin is pulled low or floated/driven high. A low disables charge (similar to a CE feature) and a high puts the charger in TTDM.

Above 60°C or below 0°C the charge is disable. Once the thermistor reaches $\pm 10^\circ\text{C}$ the TS current folds back to keep a cold thermistor (from -10°C to -50°C) from placing the IC in the TTDM mode. If the TS pin is pulled low into disable mode, the current is reduce to $\approx 30 \mu\text{A}$, see [Figure 20](#). Because the I_{TS} current is fixed along with the temperature thresholds, it is not possible to use thermistor values other than the 10k and 100k.

7.3.13 Termination and Timer Disable Mode (TTDM) -TS pin high

The battery charger is in TTDM when the TS pin goes high from removing the thermistor (removing battery pack/floating the TS pin) or by pulling the TS pin up to the TTDM threshold.

When entering TTDM, the 10 hour safety timer is held in reset and termination is disabled. A battery detect routine is run to see if the battery was removed or not. If the battery was removed then the $\overline{\text{CHG}}$ pin will go to its high impedance state if not already there. If a battery is detected the $\overline{\text{CHG}}$ pin does not change states until the current tapers to the termination threshold, where the $\overline{\text{CHG}}$ pin goes to its high impedance state if not already there (the regulated output will remain on).

The charging profile does not change (still has precharge, fast-charge constant current and constant voltage modes). This implies the battery is still charged safely and the current is allowed to taper to zero.

When coming out of TTDM, the battery detect routine is run and if a battery is detected, then a new charge cycle begins and the $\overline{\text{CHG}}$ LED turns on.

If TTDM is not desired upon removing the battery with the thermistor, one can add a 237k resistor between TS and V_{SS} to disable TTDM. This keeps the current source from driving the TS pin into TTDM. This creates $\approx 0.1^\circ\text{C}$ error at hot and a $\approx 3^\circ\text{C}$ error at cold.

7.3.14 Timers

The precharge timer is set to 30 minutes . The precharge current, can be programmed to offset any system load, making sure that the 30 minutes is adequate.

The fast charge timer is fixed at 10 hours and can be increased real time by going into thermal regulation, IN-DPM or if in USB current limit. The timer clock slows by a factor of 2, resulting in a clock than counts half as fast when in these modes. If either the 30 minute or 10-hour timer times out, the charging is terminated and the $\overline{\text{CHG}}$ pin goes high impedance if not already in that state. The timer is reset by disabling the IC, cycling power, or going into and out of TTDM.

7.3.15 Termination

Once the OUT pin goes above VRCH, (reaches voltage regulation) and the current tapers down to the termination threshold, the $\overline{\text{CHG}}$ pin goes high impedance and a battery detect route is run to determine if the battery was removed or the battery is full. If the battery is present, the charge current terminates. If the battery was removed along with the thermistor, then the TS pin is driven high and the charge enters TTDM. If the battery was removed and the TS pin is held in the active region, then the battery detect routine continues until a battery is inserted.

7.3.16 Battery Detect Routine

The battery detect routine should check for a missing battery while keeping the OUT pin at a useable voltage. Whenever the battery is missing the CHG pin should be high impedance.

The battery detect routine is run when entering and exiting TTDM to verify if battery is present, or run all the time if battery is missing and not in TTDM. On power up, if battery voltage is greater than V_{RCH} threshold, a battery detect routine is run to determine if a battery is present.

The battery detect routine will be disabled while the IC is in TTDM or has a TS fault. See [Figure 24](#) for the *Battery Detect Flow Diagram*.

7.3.17 Refresh Threshold

After termination, if the OUT pin voltage drops to V_{RCH} (100 mV below regulation) then a new charge is initiated, but the CHG pin remains at a high impedance (off).

7.3.18 Starting a Charge on a Full Battery

The termination threshold is raised by $\pm 14\%$, for the first minute of a charge cycle so if a full battery is removed and reinserted or a new charge cycle is initiated, that the new charge terminates (less than 1 minute). Batteries that have relaxed many hours may take several minutes to taper to the termination threshold and terminate charge.

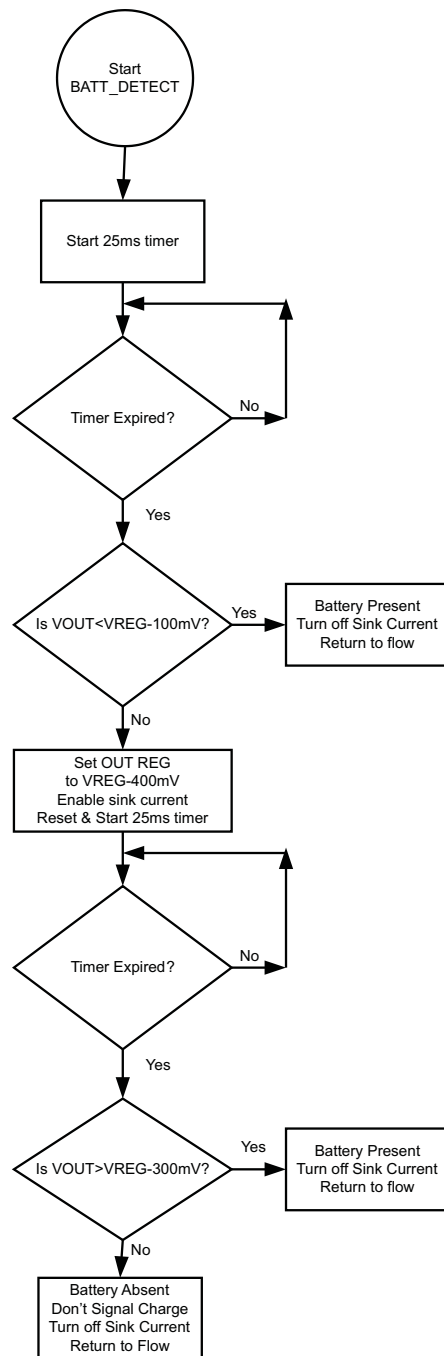

Figure 24. Battery Detect Flow Diagram

7.4 Device Functional Modes

7.4.1 Sleep Mode

If the IN pin voltage is between than $V_{OUT} + V_{DT}$ and UVLO, the charge current is disabled, the safety timer counting stops (not reset) and the \overline{PG} and CHG pins are high impedance. As the input voltage rises and the charger exits sleep mode, the \overline{PG} pin goes low, the safety timer continues to count, charge is enabled and the CHG pin returns to its previous state. See Figure 14.

7.5 Programming

7.5.1 PRE_TERM – Precharge and Termination Programmable Threshold

Pre-Term is used to program both the precharge current and the termination current threshold, on the bq2405x. The precharge current level is a factor of two higher than the termination current level. The termination can be set between 5 and 50% of the programmed output current level set by ISET. If left floating the termination and precharge are set internally at 10/20%, respectively. The precharge-to-fast-charge, V_{lowv} threshold is set to 2.5 V.

$$R_{PRE-TERM} = \%Term \times K_{TERM} = \%Pre-CHG \times K_{PRE-CHG} \quad (2)$$

Where:

$\%Term$ is the percent of fast charge current where termination occurs;

$\%Pre-CHG$ is the percent of fast charge current that is desired during precharge;

K_{TERM} and $K_{PRE-CHG}$ are gain factors found in the electrical specifications.

7.5.2 ISET2

Is a 3-state input and programs the Input Current Limit/Regulation Threshold. A low will program a regulated fast charge current via the ISET resistor and is the maximum allowed input/output current for any ISET2 setting, Float will program a 100-mA Current limit and High will program a 500-mA Current limit. Note that initially the D+/D– detection will latch the charge mode according to the source detected (dedicated charger: ISET; USB Host: at 100 mA) until the ISET2 pin has changed states, indicating the processor or transceiver is controlling the pin.

The detection routine registers the input level (Low–High–Z–High) of the ISET2 pin typically 532 μ s after applying input power ($V_{IN} > 3.4$ V – UVLO). After the detection routine is complete, which is typically 100 ms after a pullup on the D+ or D– line or after typically 570 ms if no pullup, the IC monitors the ISET2 pin for a change of state. If the state changes (Low–High–Z–High) from the one registered, for more than 5 μ s, then the "detected" latched charge mode is released and is then controlled by the ISET2 pin. The completion of the detection routine varies due to the mechanical-plugging action of the USB cable; therefore, it is best to wait ≥ 600 ms after $V_{IN} > 3.4$ V to take control of the ISET2 pin.

The following illustration shows two configurations for driving the 3-state ISET2 pin:

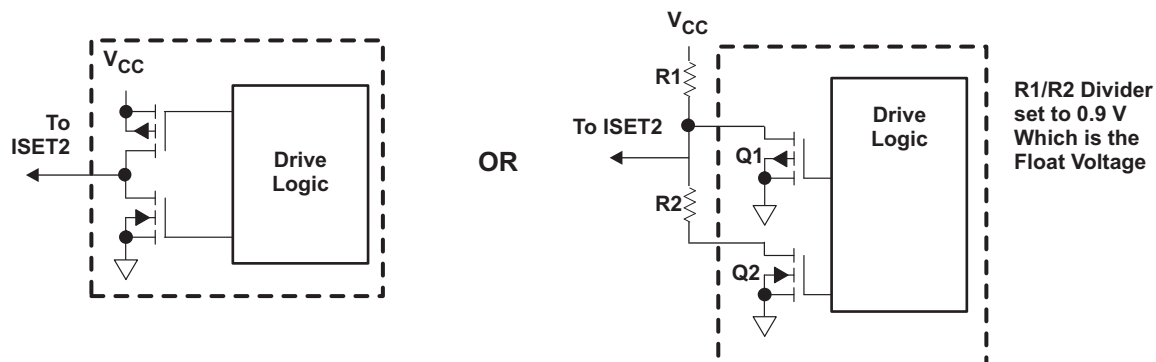

8 Application and Implementation

NOTE

Information in the following applications sections is not part of the TI component specification, and TI does not warrant its accuracy or completeness. TI's customers are responsible for determining suitability of components for their purposes. Customers should validate and test their design implementation to confirm system functionality.

8.1 Application Information

The bq2405x evaluation module (EVM) is used to perform a stand-alone evaluation for the bq2405x device family. Refer to the user's guide [SLUU378](#) for details.

8.2 Typical Applications

8.2.1 bq2405x Charger Application Design Example

The bq2405x chargers are designed to deliver up to 800 mA of continuous current to the battery output when programmed with a resistor on the ISET pin and is programmed for typically 540 mA at the factory. The USB current limit modes are selected by the ISET2 pin and ISET2 pin programs the charge current using the ISET resistor.

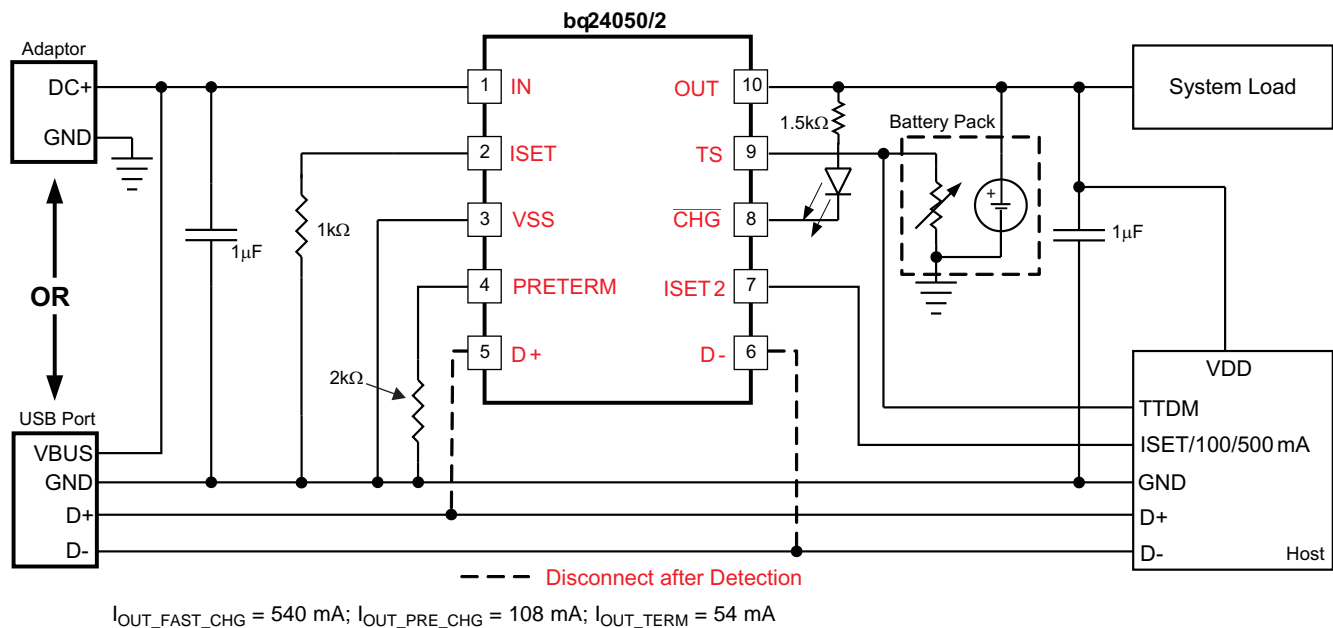

Figure 25. Typical Application Circuit, bq24050, bq24052

8.2.1.1 Design Requirements

- Supply voltage = 5 V
- Fast charge current: $I_{OUT_FC} = 540 \text{ mA}$; ISET-pin 2
- Termination Current Threshold: $\%I_{OUT_FC} = 10\%$ of Fast Charge or $\neq 54 \text{ mA}$
- Precharge Current by default is twice the termination Current or $\neq 108 \text{ mA}$
- TS – Battery Temperature Sense = 10-kΩ NTC (103AT)

Typical Applications (continued)

8.2.2 Detailed Design Procedure

8.2.2.1 Program the Fast Charge Current, ISET

$$R_{ISET} = [K_{(ISET)} / I_{(OUT)}]$$

from electrical characteristics table. . . $K_{(SET)} = 540 \text{ A}\Omega$

$$R_{ISET} = [540\text{A}\Omega/0.54\text{A}] = 1.0 \text{ k}\Omega$$

Selecting the closest standard value, use a 1-k Ω resistor between ISET (pin 16) and V_{SS} .

8.2.2.2 Program the Termination Current Threshold, ITERM

$$R_{PRE-TERM} = K_{(TERM)} \times \%_{IOUT-FC}$$

$$R_{PRE-TERM} = 200\Omega/\% \times 10\% = 2 \text{ k}\Omega$$

Selecting the closest standard value, use a 2-k Ω resistor between ITERM (pin 15) and V_{SS} .

One can arrive at the same value by using 20% for a precharge value (factor of 2 difference).

$$R_{PRE-TERM} = K_{(PRE-CHG)} \times \%_{IOUT-FC}$$

$$R_{PRE-TERM} = 100\Omega/\% \times 20\% = 2 \text{ k}\Omega$$

8.2.2.3 TS Function

Use a 10-k Ω NTC thermistor in the battery pack (103AT).

To disable the temp sense function, use a fixed 10-k Ω resistor between the TS (Pin 1) and V_{SS} .

8.2.2.4 \overline{CHG} and \overline{PG}

LED Status: connect a 1.5-k Ω resistor in series with a LED between the OUT pin and the \overline{CHG} pin. Connect a 1.5-k Ω resistor in series with a LED between the OUT pin and the \overline{PG} pin.

Processor Monitoring: Connect a pullup resistor between the power rail of the processor and the \overline{CHG} pin. Connect a pullup resistor between the power rail of the processor and the \overline{PG} pin.

8.2.2.5 Selecting IN and OUT Pin Capacitors

In most applications, all that is needed is a high-frequency decoupling capacitor (ceramic) on the power pin, input and output pins. Using the values shown on the application diagram, is recommended. After evaluation of these voltage signals with real system operational conditions, one can determine if capacitance values can be adjusted toward the minimum recommended values (DC load application) or higher values for fast high amplitude pulsed load applications. Note if designed for high input voltage sources (bad adaptors or wrong adaptors), the capacitor needs to be rated appropriately. Ceramic capacitors are tested to 2x their rated values so a 16-V capacitor may be adequate for a 30-V transient (verify tested rating with capacitor manufacturer).

Typical Applications (continued)

8.2.3 Application Curves

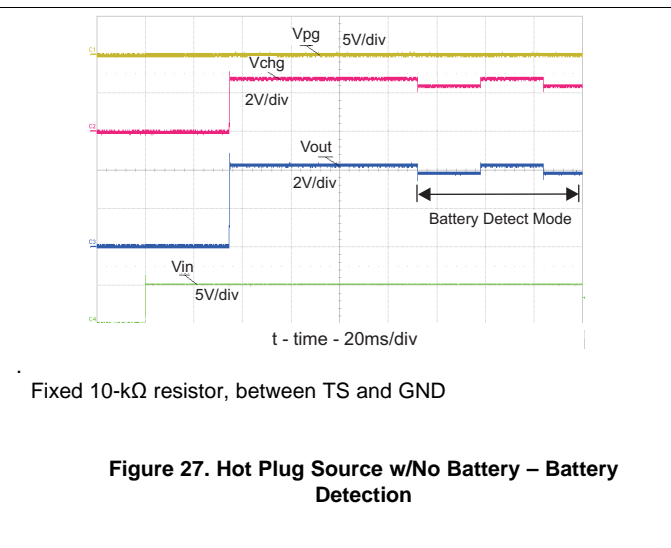
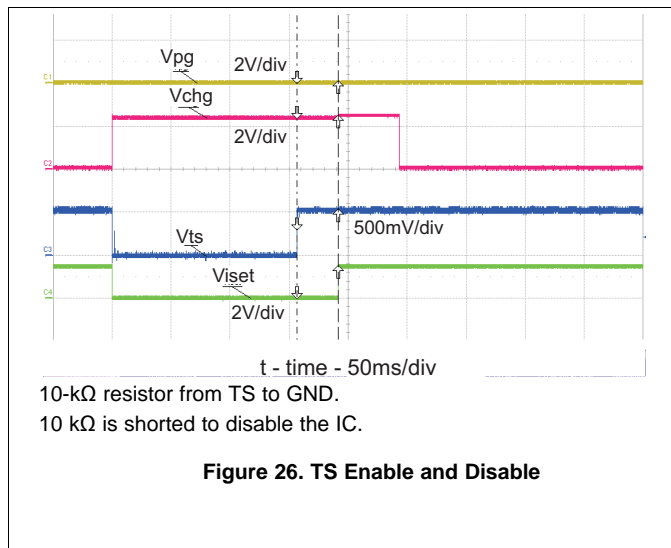

8.2.4 bq24055 Application

The bq2405x chargers are designed to deliver up to 800 mA of continuous current to the battery output when programmed with a resistor on the ISET pin and is programmed for typically 540 mA at the factory. The USB current limit modes are selected by the ISET2 pin and ISET2 pin programs the charge current using the ISET resistor.

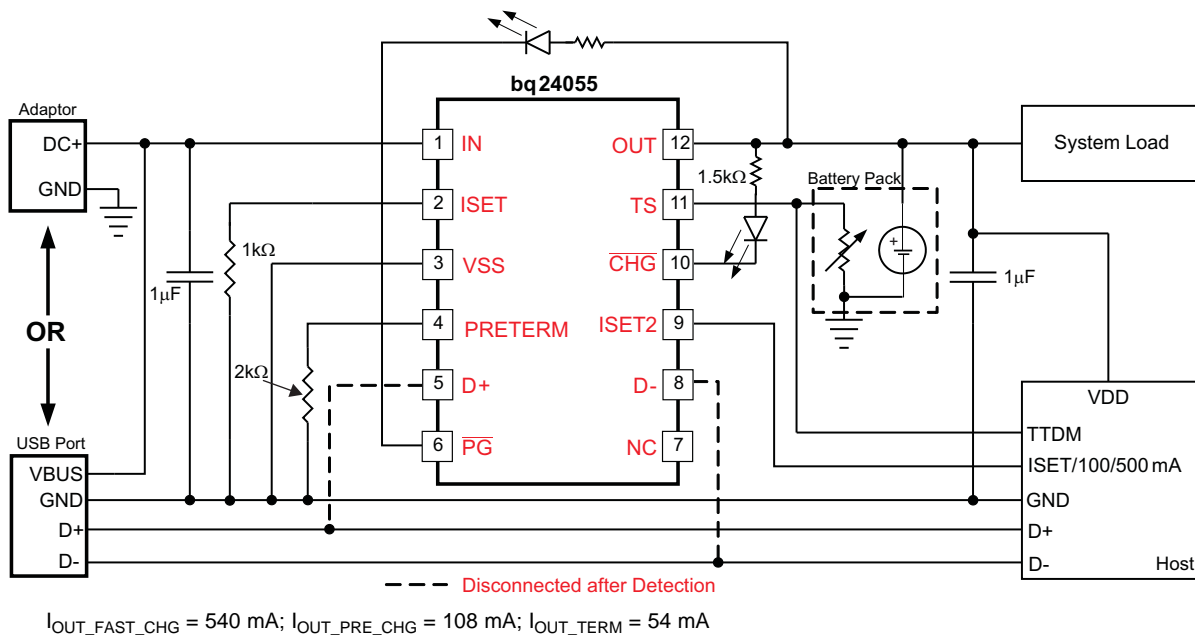

Typical Applications (continued)

8.2.4.1 Design Requirements

- Supply voltage = 5 V
- Fast charge current: $I_{OUT-FC} = 540 \text{ mA}$; ISET-pin 2
- Termination Current Threshold: $\%I_{OUT-FC} = 10\%$ of Fast Charge or $\approx 54 \text{ mA}$
- Precharge Current by default is twice the termination Current or $\approx 108 \text{ mA}$
- TS – Battery Temperature Sense = 10-k Ω NTC (103AT)

8.2.4.2 Detailed Design Procedure

8.2.4.2.1 Program the Fast Charge Current, ISET

$$R_{ISET} = [K_{(ISET)} / I_{(OUT)}]$$

from electrical characteristics table. . . $K_{(SET)} = 540 \text{ A}\Omega$

$$R_{ISET} = [540\text{A}\Omega / 0.54\text{A}] = 1.0 \text{ k}\Omega$$

Selecting the closest standard value, use a 1-k Ω resistor between ISET (pin 16) and V_{SS} .

8.2.4.2.2 Program the Termination Current Threshold, ITERM

$$R_{PRE-TERM} = K_{(TERM)} \times \%I_{OUT-FC}$$

$$R_{PRE-TERM} = 200\Omega/\% \times 10\% = 2 \text{ k}\Omega$$

Selecting the closest standard value, use a 2-k Ω resistor between ITERM (pin 15) and V_{SS} .

One can arrive at the same value by using 20% for a precharge value (factor of 2 difference).

$$R_{PRE-TERM} = K_{(PRE-CHG)} \times \%I_{OUT-FC}$$

$$R_{PRE-TERM} = 100\Omega/\% \times 20\% = 2 \text{ k}\Omega$$

8.2.4.2.3 TS Function

Use a 10-k Ω NTC thermistor in the battery pack (103AT).

To disable the temp sense function, use a fixed 10-k Ω resistor between the TS (Pin 1) and V_{SS} .

8.2.4.2.4 $\overline{\text{CHG}}$ and $\overline{\text{PG}}$

LED Status: connect a 1.5-k Ω resistor in series with a LED between the OUT pin and the $\overline{\text{CHG}}$ pin. Connect a 1.5-k Ω resistor in series with a LED between the OUT pin and the $\overline{\text{PG}}$ pin.

Processor Monitoring: Connect a pullup resistor between the power rail of the processor and the $\overline{\text{CHG}}$ pin. Connect a pullup resistor between the power rail of the processor and the $\overline{\text{PG}}$ pin.

8.2.4.2.5 Selecting IN and OUT Pin Capacitors

In most applications, all that is needed is a high-frequency decoupling capacitor (ceramic) on the power pin, input and output pins. Using the values shown on the application diagram, is recommended. After evaluation of these voltage signals with real system operational conditions, one can determine if capacitance values can be adjusted toward the minimum recommended values (DC load application) or higher values for fast high amplitude pulsed load applications. Note if designed for high input voltage sources (bad adaptors or wrong adaptors), the capacitor needs to be rated appropriately. Ceramic capacitors are tested to 2x their rated values so a 16-V capacitor may be adequate for a 30-V transient (verify tested rating with capacitor manufacturer).

Typical Applications (continued)

8.2.4.3 Application Curves

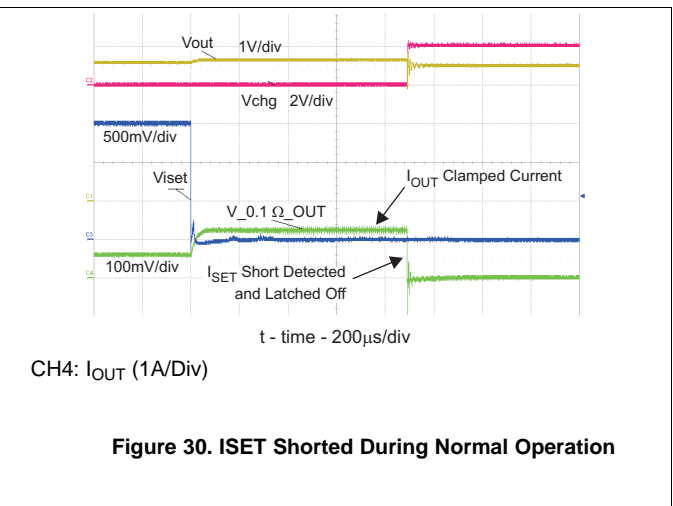
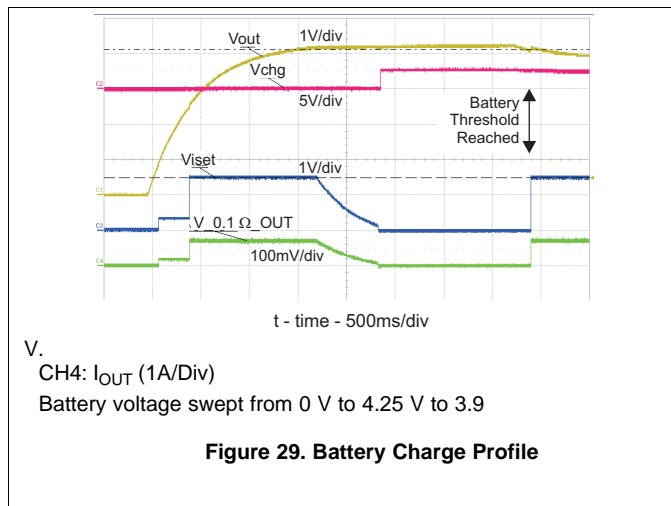

9 Power Supply Recommendations

The devices are designed to operate from an input voltage supply range between 3.5 V and 28 V and current capability of at least the maximum designed charge current. This input supply should be well regulated. If located more than a few inches from the bq2405x IN and GND terminals, a larger capacitor is recommended.

10 Layout

10.1 Layout Guidelines

To obtain optimal performance, the decoupling capacitor from IN to GND (thermal pad) and the output filter capacitors from OUT to GND (thermal pad) should be placed as close as possible to the bq2405x, with short trace runs to both IN, OUT and GND (thermal pad).

- All low-current GND connections should be kept separate from the high-current charge or discharge paths from the battery. Use a single-point ground technique incorporating both the small signal ground path and the power ground path.
- The high current charge paths into IN pin and from the OUT pin must be sized appropriately for the maximum charge current in order to avoid voltage drops in these traces
- The bq2405x family is packaged in a thermally enhanced MLP package. The package includes a thermal pad to provide an effective thermal contact between the IC and the printed circuit board (PCB); this thermal pad is also the main ground connection for the device. Connect the thermal pad to the PCB ground connection. It is best to use multiple 10-mil vias in the power pad of the IC and in close proximity to conduct the heat to the bottom ground plane. The bottom ground plane should avoid traces that “cut off” the thermal path. The thinner the PCB the less temperature rise. The EVM PCB has a thickness of 0.031 inches and uses 2 oz. (2.8-mil thick) copper on top and bottom, and is a good example of optimal thermal performance.

10.2 Layout Example

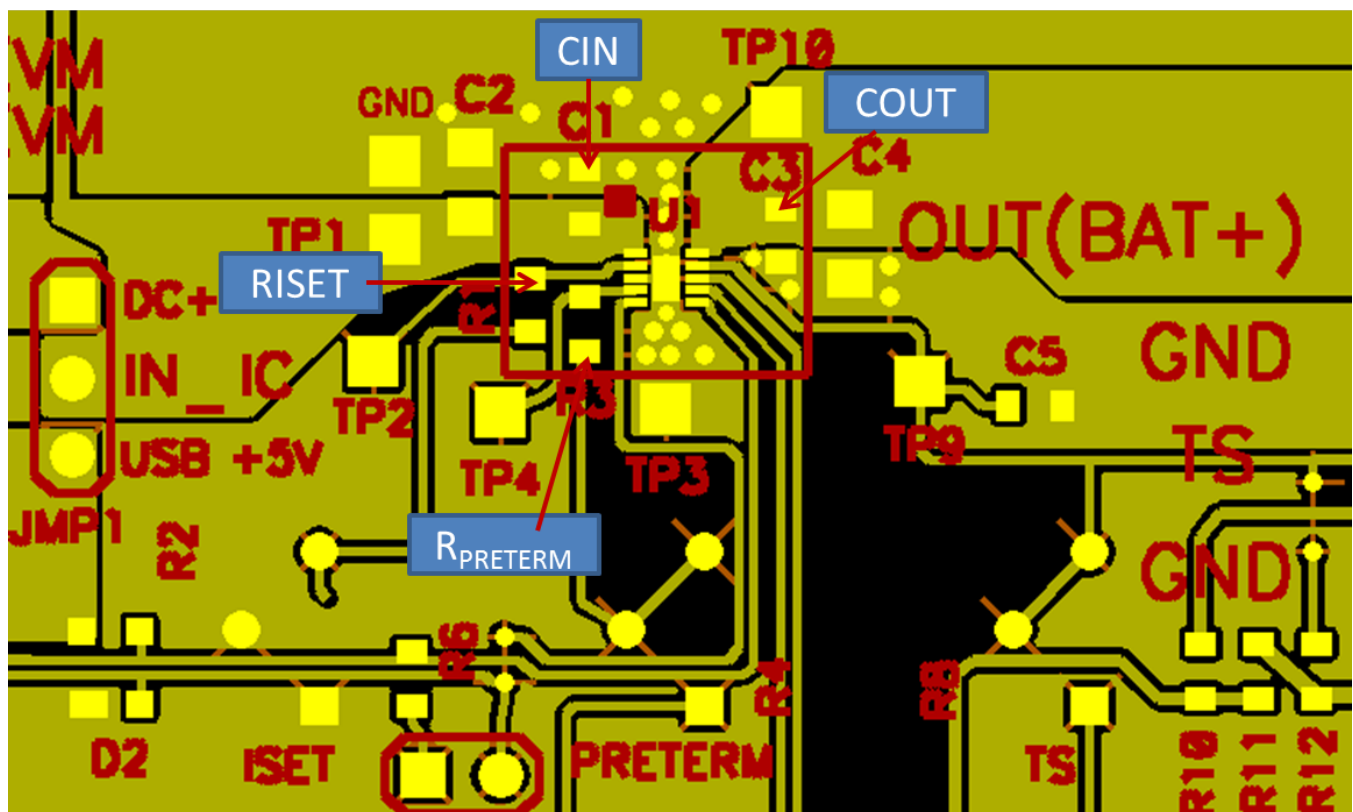

10.3 Thermal Considerations

The bq2405x family is packaged in a thermally enhanced MLP package. The package includes a thermal pad to provide an effective thermal contact between the IC and the printed circuit board (PCB). The power pad should be directly connected to the VSS pin. Full PCB design guidelines for this package are provided in the *QFN/SON PCB Attachment Application Note* application note (SLUA271). The most common measure of package thermal performance is thermal impedance (θ_{JA}) measured (or modeled) from the chip junction to the air surrounding the package surface (ambient). The mathematical expression for θ_{JA} is:

$$\theta_{JA} = (T_J - T) / P \quad (3)$$

Where:

- T_J = chip junction temperature
- T = ambient temperature
- P = device power dissipation

Factors that can influence the measurement and calculation of θ_{JA} include:

1. Whether or not the device is board mounted
2. Trace size, composition, thickness, and geometry
3. Orientation of the device (horizontal or vertical)
4. Volume of the ambient air surrounding the device under test and airflow
5. Whether other surfaces are in close proximity to the device being tested

Due to the charge profile of Li-Ion and Li-Pol batteries the maximum power dissipation is typically seen at the beginning of the charge cycle when the battery voltage is at its lowest. Typically after fast charge begins the pack voltage increases to ≈ 3.4 V within the first 2 minutes. The thermal time constant of the assembly typically takes a few minutes to heat up so when doing maximum power dissipation calculations, 3.4 V is a good minimum voltage to use. This is verified, with the system and a fully discharged battery, by plotting temperature on the bottom of the PCB under the IC (pad should have multiple vias), the charge current and the battery voltage as a function of time. The fast charge current will start to taper off if the part goes into thermal regulation.

The device power dissipation, P , is a function of the charge rate and the voltage drop across the internal PowerFET. It can be calculated from the following equation when a battery pack is being charged:

$$P = [V_{(IN)} - V_{(OUT)}] \times I_{(OUT)} + [V_{(OUT)} - V_{(OUT)}] \times I_{(OUT)} \quad (4)$$

The thermal loop feature reduces the charge current to limit excessive IC junction temperature. TI recommends that the design not run in thermal regulation for typical operating conditions (nominal input voltage and nominal ambient temperatures) and use the feature for nontypical situations such as hot environments or higher than normal input source voltage. With that said, the IC will still perform as described, if the thermal loop is always active.

10.3.1 Leakage Current Effects on Battery Capacity

To determine how fast a leakage current on the battery discharges, the battery is used for the calculation. The time from full to discharge can be calculated by dividing the Amp-Hour Capacity of the battery by the leakage current. For a 0.75Ahr battery and a 10- μ A leakage current (750mAh/0.010mA = 75000 hours), it would take 75k hours or 8.8 years to discharge. In reality, the self discharge of the cell is much faster, so the 10 μ A leakage would be considered negligible.

11 Device and Documentation Support

11.1 Documentation Support

11.1.1 Related Documentation

For related documentation see the following:

QFN/SON PCB Attachment Application Note, [SLUA271](#)

11.2 Related Links

The table below lists quick access links. Categories include technical documents, support and community resources, tools and software, and quick access to sample or buy.

Table 1. Related Links

PARTS	PRODUCT FOLDER	SAMPLE & BUY	TECHNICAL DOCUMENTS	TOOLS & SOFTWARE	SUPPORT & COMMUNITY
bq24050	Click here	Click here	Click here	Click here	Click here
bq24052	Click here	Click here	Click here	Click here	Click here
bq24055	Click here	Click here	Click here	Click here	Click here

11.3 Trademarks

All trademarks are the property of their respective owners.

11.4 Electrostatic Discharge Caution



These devices have limited built-in ESD protection. The leads should be shorted together or the device placed in conductive foam during storage or handling to prevent electrostatic damage to the MOS gates.

11.5 Glossary

[SLYZ022](#) — *TI Glossary*.

This glossary lists and explains terms, acronyms, and definitions.

12 Mechanical, Packaging, and Orderable Information

The following pages include mechanical, packaging, and orderable information. This information is the most current data available for the designated devices. This data is subject to change without notice and revision of this document. For browser-based versions of this data sheet, refer to the left-hand navigation.

PACKAGING INFORMATION

Orderable Device	Status (1)	Package Type	Package Drawing	Pins	Package Qty	Eco Plan (2)	Lead/Ball Finish (6)	MSL Peak Temp (3)	Op Temp (°C)	Device Marking (4/5)	Samples
BQ24050DSQR	ACTIVE	WSO	DSQ	10	3000	Green (RoHS & no Sb/Br)	CU NIPDAU	Level-2-260C-1 YEAR		CVC	Samples
BQ24050DSQT	ACTIVE	WSO	DSQ	10	250	Green (RoHS & no Sb/Br)	CU NIPDAU	Level-2-260C-1 YEAR		CVC	Samples
BQ24052DSQR	ACTIVE	WSO	DSQ	10	3000	Green (RoHS & no Sb/Br)	CU NIPDAU	Level-2-260C-1 YEAR		CGT	Samples
BQ24052DSQT	ACTIVE	WSO	DSQ	10	250	Green (RoHS & no Sb/Br)	CU NIPDAU	Level-2-260C-1 YEAR		CGT	Samples

(1) The marketing status values are defined as follows:

ACTIVE: Product device recommended for new designs.

LIFEBUY: TI has announced that the device will be discontinued, and a lifetime-buy period is in effect.

NRND: Not recommended for new designs. Device is in production to support existing customers, but TI does not recommend using this part in a new design.

PREVIEW: Device has been announced but is not in production. Samples may or may not be available.

OBSELETE: TI has discontinued the production of the device.

(2) **RoHS:** TI defines "RoHS" to mean semiconductor products that are compliant with the current EU RoHS requirements for all 10 RoHS substances, including the requirement that RoHS substance do not exceed 0.1% by weight in homogeneous materials. Where designed to be soldered at high temperatures, "RoHS" products are suitable for use in specified lead-free processes. TI may reference these types of products as "Pb-Free".

RoHS Exempt: TI defines "RoHS Exempt" to mean products that contain lead but are compliant with EU RoHS pursuant to a specific EU RoHS exemption.

Green: TI defines "Green" to mean the content of Chlorine (Cl) and Bromine (Br) based flame retardants meet JS709B low halogen requirements of <=1000ppm threshold. Antimony trioxide based flame retardants must also meet the <=1000ppm threshold requirement.

(3) MSL, Peak Temp. - The Moisture Sensitivity Level rating according to the JEDEC industry standard classifications, and peak solder temperature.

(4) There may be additional marking, which relates to the logo, the lot trace code information, or the environmental category on the device.

(5) Multiple Device Markings will be inside parentheses. Only one Device Marking contained in parentheses and separated by a "-" will appear on a device. If a line is indented then it is a continuation of the previous line and the two combined represent the entire Device Marking for that device.

(6) Lead/Ball Finish - Orderable Devices may have multiple material finish options. Finish options are separated by a vertical ruled line. Lead/Ball Finish values may wrap to two lines if the finish value exceeds the maximum column width.

Important Information and Disclaimer:The information provided on this page represents TI's knowledge and belief as of the date that it is provided. TI bases its knowledge and belief on information provided by third parties, and makes no representation or warranty as to the accuracy of such information. Efforts are underway to better integrate information from third parties. TI has taken and

continues to take reasonable steps to provide representative and accurate information but may not have conducted destructive testing or chemical analysis on incoming materials and chemicals. TI and TI suppliers consider certain information to be proprietary, and thus CAS numbers and other limited information may not be available for release.

In no event shall TI's liability arising out of such information exceed the total purchase price of the TI part(s) at issue in this document sold by TI to Customer on an annual basis.

TAPE AND REEL INFORMATION



QUADRANT ASSIGNMENTS FOR PIN 1 ORIENTATION IN TAPE



*All dimensions are nominal

Device	Package Type	Package Drawing	Pins	SPQ	Reel Diameter (mm)	Reel Width W1 (mm)	A0 (mm)	B0 (mm)	K0 (mm)	P1 (mm)	W (mm)	Pin1 Quadrant
BQ24050DSQR	WSON	DSQ	10	3000	180.0	8.4	2.2	2.2	1.2	4.0	8.0	Q2
BQ24050DSQT	WSON	DSQ	10	250	179.0	8.4	2.2	2.2	1.2	4.0	8.0	Q2
BQ24052DSQR	WSON	DSQ	10	3000	179.0	8.4	2.2	2.2	1.2	4.0	8.0	Q2
BQ24052DSQT	WSON	DSQ	10	250	179.0	8.4	2.2	2.2	1.2	4.0	8.0	Q2

TAPE AND REEL BOX DIMENSIONS

*All dimensions are nominal

Device	Package Type	Package Drawing	Pins	SPQ	Length (mm)	Width (mm)	Height (mm)
BQ24050DSQR	WSON	DSQ	10	3000	195.0	200.0	45.0
BQ24050DSQT	WSON	DSQ	10	250	195.0	200.0	45.0
BQ24052DSQR	WSON	DSQ	10	3000	195.0	200.0	45.0
BQ24052DSQT	WSON	DSQ	10	250	195.0	200.0	45.0

EXAMPLE STENCIL DESIGN

DSQ0010A

WSON - 0.8 mm max height

PLASTIC SMALL OUTLINE - NO LEAD

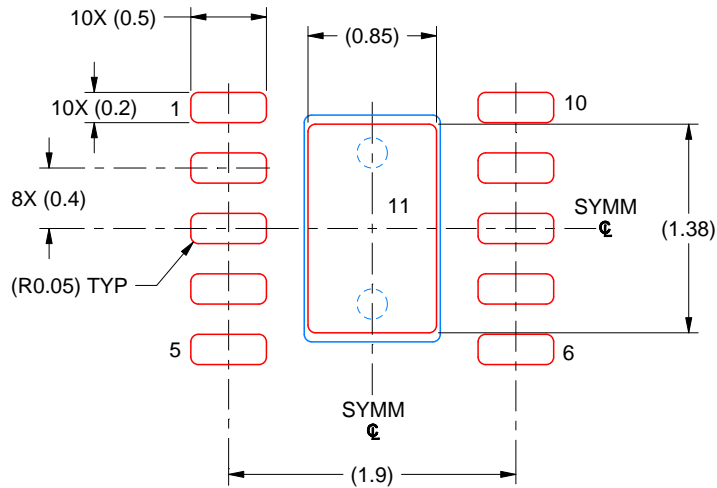

SOLDER PASTE EXAMPLE
BASED ON 0.125 MM THICK STENCIL
SCALE: 20X

EXPOSED PAD 11
87% PRINTED SOLDER COVERAGE BY AREA UNDER PACKAGE

4218906/A 04/2019

NOTES: (continued)

6. Laser cutting apertures with trapezoidal walls and rounded corners may offer better paste release. IPC-7525 may have alternate design recommendations.

IMPORTANT NOTICE AND DISCLAIMER

TI PROVIDES TECHNICAL AND RELIABILITY DATA (INCLUDING DATASHEETS), DESIGN RESOURCES (INCLUDING REFERENCE DESIGNS), APPLICATION OR OTHER DESIGN ADVICE, WEB TOOLS, SAFETY INFORMATION, AND OTHER RESOURCES "AS IS" AND WITH ALL FAULTS, AND DISCLAIMS ALL WARRANTIES, EXPRESS AND IMPLIED, INCLUDING WITHOUT LIMITATION ANY IMPLIED WARRANTIES OF MERCHANTABILITY, FITNESS FOR A PARTICULAR PURPOSE OR NON-INFRINGEMENT OF THIRD PARTY INTELLECTUAL PROPERTY RIGHTS.

These resources are intended for skilled developers designing with TI products. You are solely responsible for (1) selecting the appropriate TI products for your application, (2) designing, validating and testing your application, and (3) ensuring your application meets applicable standards, and any other safety, security, or other requirements. These resources are subject to change without notice. TI grants you permission to use these resources only for development of an application that uses the TI products described in the resource. Other reproduction and display of these resources is prohibited. No license is granted to any other TI intellectual property right or to any third party intellectual property right. TI disclaims responsibility for, and you will fully indemnify TI and its representatives against, any claims, damages, costs, losses, and liabilities arising out of your use of these resources.

TI's products are provided subject to TI's Terms of Sale (www.ti.com/legal/termsofsale.html) or other applicable terms available either on ti.com or provided in conjunction with such TI products. TI's provision of these resources does not expand or otherwise alter TI's applicable warranties or warranty disclaimers for TI products.

Mailing Address: Texas Instruments, Post Office Box 655303, Dallas, Texas 75265
Copyright © 2019, Texas Instruments Incorporated

Looking for pricing, stock, or lifecycle information?

Click below to explore more details on WIN SOURCE:

 [View BQ24055DSST](#) on WIN SOURCE

 [Texas Instruments](#) Information

Optimize Your Supply Chain with WIN SOURCE Solutions

-  Global Sourcing Solution
-  Obsolete Management
-  Cost Control Management
-  Shortage Management
-  Alternative Solution
-  Excess Inventory Management