



**THE DATASHEET OF  
BQ24040DSQT**



# BQ2404x 1A, Single-Input, Single Cell Li-Ion and Li-Pol Battery Charger With Auto Start

## 1 Features

- Charging
  - 1% Charge voltage accuracy
  - 10% Charge current accuracy
  - Pin selectable USB 100 mA and 500 mA maximum input current limit
  - Programmable termination and precharge threshold, BQ24040 and BQ24045
  - High voltage (4.35 V) chemistry support with BQ24045
- Protection
  - 30V Input rating; with 6.6 V or 7.1 V input overvoltage protection
  - Input voltage dynamic power management
  - 125°C thermal regulation; 150°C thermal shutdown protection
  - OUT Short-circuit protection and ISET short detection
  - Operation over JEITA range via battery NTC – 1/2 fast-charge-current at Cold, 4.06V at Hot, BQ24040 and BQ24045
  - Fixed 10 hour safety timer, BQ24040 and BQ24045
- System
  - Automatic termination and timer disable mode (TTDM) for absent battery pack with thermistor, BQ24040 and BQ24045
  - Status indication – charging and done
  - Available in small 2 × 2 mm<sup>2</sup> DFN-10 package
  - Integrated auto start function for production line testing, BQ24041
- [Functional Safety-Capable \(BQ24040\)](#)
  - [Documentation available to aid functional safety system design](#)
- Safety-Related Certifications:
  - IEC 62368-1 CB Certification (BQ24040, BQ24045)

## 2 Applications

- TWS Headsets and headphones
- Smartwatches and wristbands
- Wireless speakers
- Mobile POS
- Portable medical devices

## 3 Description

The BQ2404x series of devices are highly integrated Li-Ion and Li-Pol linear chargers devices targeted at space-limited portable applications. The devices operate from either a USB port or AC adapter. The high input voltage range with input overvoltage protection supports low-cost unregulated adapters.

The BQ2404x has a single power output that charges the battery. A system load can be placed in parallel with the battery as long as the average system load does not keep the battery from charging fully during the 10 hour safety timer.

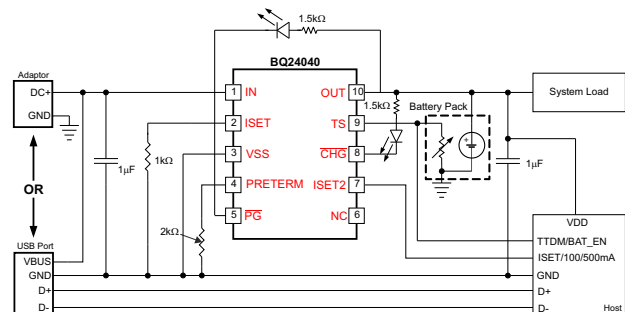
The battery is charged in three phases: conditioning, constant current and constant voltage. In all charge phases, an internal control loop monitors the IC junction temperature and reduces the charge current if an internal temperature threshold is exceeded.

The charger power stage and charge current sense functions are fully integrated. The charger function has high accuracy current and voltage regulation loops, charge status display, and charge termination. The pre-charge current and termination current threshold are programmed through an external resistor on the BQ24040 and BQ24045. The fast charge current value is also programmable through an external resistor.

### Device Information

PART NUMBER <sup>(1)</sup>	PACKAGE	BODY SIZE (NOM)
BQ24040	WSON (10)	2.00 mm x 2.00 mm
BQ24041		
BQ24045		

(1) For all available packages, see the orderable addendum at the end of the data sheet.



**Simplified Schematic**



## Table of Contents

<b>1 Features</b> .....	1	8.4 Device Functional Modes.....	17
<b>2 Applications</b> .....	1	<b>9 Application and Implementation</b> .....	22
<b>3 Description</b> .....	1	9.1 Application Information.....	22
<b>4 Revision History</b> .....	2	9.2 Typical Applications.....	22
<b>5 Device Comparison</b> .....	4	<b>10 Power Supply Recommendations</b> .....	29
<b>6 Pin Configuration and Functions</b> .....	4	<b>11 Layout</b> .....	30
<b>7 Specifications</b> .....	6	11.1 Layout Guidelines.....	30
7.1 Absolute Maximum Ratings.....	6	11.2 Layout Example.....	30
7.2 ESD Ratings.....	6	11.3 Thermal Considerations.....	31
7.3 Recommended Operating Conditions.....	6	<b>12 Device and Documentation Support</b> .....	32
7.4 Thermal Information.....	7	12.1 Device Support.....	32
7.5 Electrical Characteristics.....	7	12.2 Documentation Support.....	32
7.6 Timing Requirements.....	10	12.3 Receiving Notification of Documentation Updates.....	32
7.7 Typical Operational Characteristics (Protection Circuits Waveforms).....	11	12.4 Support Resources.....	32
<b>8 Detailed Description</b> .....	12	12.5 Trademarks.....	32
8.1 Overview.....	12	12.6 Electrostatic Discharge Caution.....	32
8.2 Functional Block Diagram.....	13	12.7 Glossary.....	32
8.3 Feature Description.....	14	<b>13 Mechanical, Packaging, and Orderable Information</b> .....	32

## 4 Revision History

NOTE: Page numbers for previous revisions may differ from page numbers in the current version.

Changes from Revision G (June 2020) to Revision H (February 2021)	Page
• Added BQ24040, BQ24045 to IEC 62368-1 CB Certification Feature.....	1
• Changed $I_{BD-SINK}$ minimum from 7 mA to 6 mA.....	7
• Changed $I_{IH}$ maximum from 8 $\mu$ A to 9.5 $\mu$ A.....	7

Changes from Revision F (March 2015) to Revision G (June 2020)	Page
• Added Functional Safety-Capable Feature .....	1
• Added IEC 62368-1 Feature.....	1
• Changed Applications.....	1
• Deleted Disconnect after Detection from Simplified Schematic.....	1
• Changed thermal pad description .....	4
• Added $I_{OUT(SC)}$ test condition .....	7
• Changed <a href="#">Figure 7-5</a> .....	11
• Changed the <a href="#">Section 8.3.4</a> section .....	14
• Added (BQ24040) to <a href="#">Figure 8-4</a> and <a href="#">Figure 8-5</a> .....	18
• Deleted Disconnect after Detection from <a href="#">Figure 9-1</a> .....	22
• Added link to BQ24040 Application Report.....	23
• Deleted Disconnect after Detection from <a href="#">Figure 9-20</a> .....	27
• Moved <a href="#">Section 11.3</a> to <i>Layout</i> section .....	31

Changes from Revision E (February 2014) to Revision F (March 2015)	Page
• Changed the <i>Device Information</i> table header information, and removed the package designation from the device number .....	1
• Changed the <i>Terminal Configuration and Functions</i> To: <a href="#">Section 6</a> .....	4
• The storage temperature range has been moved to the <a href="#">Section 7.1</a> .....	6
• Changed the <i>Handling Ratings</i> table To: <a href="#">Section 7.2</a> and updated the guidelines.....	6

- Added the package family to the column heading in the [Section 7.4](#)..... 7
- Added the NOTE to the [Section 9](#) ..... 22

---

**Changes from Revision D (March 2013) to Revision E (February 2014) Page**

- Added *Handling Ratings* table , *Feature Description* section, *Device Functional Modes* section, *Application and Implementation* section, *Power Supply Recommendations* section, *Layout* section, *Device and Documentation Support* section, and *Mechanical, Packaging, and Orderable Information* section..... 1
- Changed the Dissipation Rating table to the [Section 7.4](#)..... 7
- Changed  $V_{O\_HT(REG)}$  in the Electrical Characteristics table to include new values BQ24045..... 7
- Added the Timing Requirements table.....10
- Deleted the last sentence in the first paragraph of the TS (BQ24040/5) section .....19
- Added the [Section 9.2.1.3](#) ..... 24

---

**Changes from Revision C (February 2013) to Revision D (March 2013) Page**

- Changed Feature From: Fixed 10 Hour Safety Timer To: Fixed 10 Hour Safety Timer, BQ24040 and BQ24045 ..... 1
- Changed the OUT terminal *DESCRIPTION* ..... 4
- Changed  $R_{ISET}$  NOM value in the ROC table From: 49.9 k $\Omega$  To: 10.8 k $\Omega$ .....6
- Changed  $R_{ISET\_SHORT}$  test conditions From:  $R_{ISET} : 600\Omega \rightarrow 250\Omega$  To:  $R_{ISET} : 540\Omega \rightarrow 250\Omega$ ..... 7
- Changed  $I_{OUT\_CL}$  test conditions From:  $R_{ISET} : 600\Omega \rightarrow 250\Omega$  To:  $R_{ISET} : 540\Omega \rightarrow 250\Omega$ ..... 7
- Deleted: Internally Set: BQ24041 from the TERMINATION section..... 7
- Added BQ24040 and BQ24045 only to the BATTERY CHARGING TIMERS AND FAULT TIMERS section...10
- Changed text in the ISET section From: "maximum current between 1.1A and 1.35A" To: "maximum current between 1.05A and 1.4A"..... 18
- Changed the Timers section.....20
- Deleted:  $I_{OUT\_TERM} = 54mA$  from the Typical Application Circuit: BQ24041, with ASI and ASO conditions.....27

---

**Changes from Revision B (June 2012) to Revision C (February 2013) Page**

- Added device BQ24045..... 1
- Added additional  $K_{ISET}$  information to the Electrical Characteristics table.....7
- Added graph - Load Regulation..... 11
- Added graph - Line Regulation..... 11

---

**Changes from Revision A (September 2009) to Revision B (June 2012) Page**

- Changed all occurrences of Li-Ion To: Li-Ion and Li-Pol..... 1

---

**Changes from Revision \* (August 2009) to Revision A (September 2009) Page**

- Changed the status of the devices From: Product Preview To: Production Data..... 1

## 5 Device Comparison

PART NO.	V <sub>O(REG)</sub>	V <sub>OVP</sub>	PreTerm	ASI/ASO	TS/BAT_EN	PG	PACKAGE
BQ24040	4.20 V	6.6 V	Yes	No	TS (JEITA)	Yes	10-pin 2 × 2mm <sup>2</sup> DFN
BQ24041	4.20 V	7.1 V	No	Yes	BAT_EN Termination Disabled	Yes	10-pin 2 × 2mm <sup>2</sup> DFN
BQ24045	4.35V	6.6V	Yes	No	TS (JEITA)	Yes	10-pin 2 × 2mm <sup>2</sup> DFN

## 6 Pin Configuration and Functions

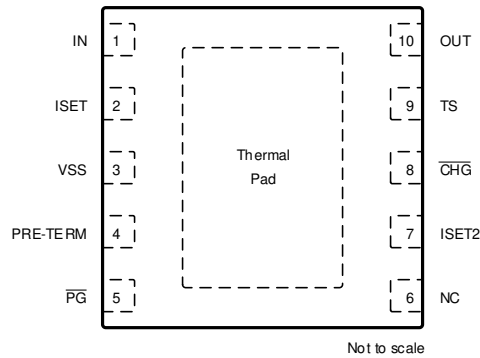


Figure 6-1. BQ24040 and BQ24045 DSQ Package 10-Pin WSON Top View

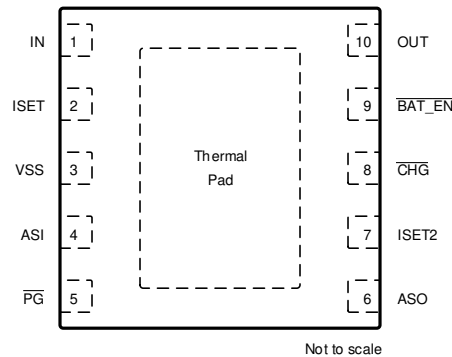


Figure 6-2. BQ24041 DSQ Package 10-Pin WSON Top View

Table 6-1. Pin Functions

NAME	PIN		I/O	DESCRIPTION
	BQ24040 BQ24045	BQ24041		
IN	1	1	I	Input power, connected to external DC supply (AC adapter or USB port). Expected range of bypass capacitors 1μF to 10μF, connect from IN to V <sub>SS</sub> .
OUT	10	10	O	Battery Connection. System Load may be connected. Expected range of bypass capacitors 1μF to 10μF.
PRE-TERM	4	–	I	Programs the Current Termination Threshold (5 to 50% of I <sub>out</sub> which is set by ISET) and Sets the Pre-Charge Current to twice the Termination Current Level. Expected range of programming resistor is 1k to 10kΩ (2k: I <sub>pgm</sub> /10 for term; I <sub>pgm</sub> /5 for precharge)
ISET	2	2	I	Programs the Fast-charge current setting. External resistor from ISET to V <sub>SS</sub> defines fast charge current value. Range is 10.8k (50mA) to 540Ω (1000mA).
ISET2	7	7	I	Programming the Input/Output Current Limit for the USB or Adaptor source: BQ24040/5 => High = 500mA <sub>max</sub> , Low = ISET, FLOAT = 100mA <sub>max</sub> . BQ24041 => High = 410mA <sub>max</sub> , Low = ISET, FLOAT = 100mA <sub>max</sub> .
TS	g <sup>(1)</sup>	–	I	Temperature sense terminal connected to BQ24040/5 -10k at 25°C NTC thermistor, in the battery pack. Floating T terminal or pulling High puts part in TTDM "Charger" Mode and disable TS monitoring, Timers and Termination. Pulling terminal Low disables the IC. If NTC sensing is not needed, connect this terminal to V <sub>SS</sub> through an external 10 kΩ resistor. A 250kΩ from TS to ground will prevent IC entering TTDM mode when battery with thermistor is removed.
BAT_EN	–	9	I	Charge Enable Input (active low)
VSS	3	3	–	Ground terminal
CHG	8	8	O	Low (FET on) indicates charging and Open Drain (FET off) indicates no Charging or Charge complete.
PG	5	5	O	Low (FET on) indicates the input voltage is above UVLO and the OUT (battery) voltage.

**Table 6-1. Pin Functions (continued)**

NAME	PIN		I/O	DESCRIPTION
	BQ24040 BQ24045	BQ24041		
ASI	–	4	I	Auto start External input. Internal 200kΩ pull-down.
ASO	–	6	O	Auto Start Logic Output
NC	6	–	NA	Do not make a connection to this terminal (for internal use) – Do not route through this terminal
Thermal Pad and Package	Pad 2x2mm <sup>2</sup>	Pad 2x2mm <sup>2</sup>	–	Connect exposed thermal pad to VSS terminal of the device and main ground plane. The thermal pad must be connected to the same potential as the VSS terminal on the printed circuit board. Do not use the thermal pad as the primary ground input for the device. VSS terminal must be connected to ground at all times.

(1) Spins have different terminal definitions

## 7 Specifications

### 7.1 Absolute Maximum Ratings

over operating free-air temperature range (unless otherwise noted)<sup>(1)</sup>

		MIN	MAX	UNIT
Input voltage	IN (with respect to VSS)	-0.3	30	V
	OUT (with respect to VSS)	-0.3	7	V
	PRE-TERM, ISET, ISET2, TS, CHG, PG, ASI, ASO (with respect to VSS)	-0.3	7	V
Input current	IN		1.25	A
Output current (continuous)	OUT		1.25	A
Output sink current	CHG		15	mA
T <sub>J</sub>	Junction temperature	-40	150	°C
T <sub>stg</sub>	Storage temperature	-65	150	°C

- (1) Stresses beyond those listed under absolute maximum ratings may cause permanent damage to the device. These are stress ratings only, and functional operation of the device at these or any other conditions beyond those indicated under recommended operating conditions is not implied. Exposure to absolute-maximum-rated conditions for extended periods may affect device reliability. All voltage values are with respect to the network ground terminal unless otherwise noted.

### 7.2 ESD Ratings

		VALUE	UNIT
V <sub>(ESD)</sub>	Electrostatic discharge <sup>(3)</sup>		
	Human-body model (HBM), per ANSI/ESDA/JEDEC JS-001 <sup>(1)</sup>	±3000	V
Charged-device model (CDM), per JEDEC specification JESD22-C101 or ANSI/ESDA/JEDEC JS-002 <sup>(2)</sup>	±1500		

- (1) JEDEC document JEP155 states that 500-V HBM allows safe manufacturing with a standard ESD control process.  
 (2) JEDEC document JEP157 states that 250-V CDM allows safe manufacturing with a standard ESD control process.  
 (3) The test was performed on IC terminals that may potentially be exposed to the customer at the product level. The BQ2404x IC requires a minimum of the listed capacitance, external to the IC, to pass the ESD test. The D+ D- lines require clamp diodes such as CM1213A-02SR from CMD to protect the IC for this testing.

### 7.3 Recommended Operating Conditions

see <sup>(1)</sup>

		MIN	NOM	UNIT
V <sub>IN</sub>	IN voltage range	3.5	28	V
	IN operating voltage range, Restricted by V <sub>DPM</sub> and V <sub>OVP</sub>	4.45	6.45	V
I <sub>IN</sub>	Input current, IN terminal		1	A
I <sub>OUT</sub>	Current, OUT terminal		1	A
T <sub>J</sub>	Junction temperature	0	125	°C
R <sub>PRE-TERM</sub>	Programs precharge and termination current thresholds	1	10	kΩ
R <sub>ISET</sub>	Fast-charge current programming resistor	0.540	10.8	kΩ
R <sub>TS</sub>	10k NTC thermistor range without entering BAT_EN or TTDM	1.66	258	kΩ

- (1) Operation with V<sub>IN</sub> less than 4.5V or in drop-out may result in reduced performance.

## 7.4 Thermal Information

THERMAL METRIC <sup>(1)</sup>		BQ2404x	UNIT
		DSQ (WSON)	
		10 PINS	
R <sub>θJA</sub>	Junction-to-ambient thermal resistance	63.5	°C/W
R <sub>θJC(top)</sub>	Junction-to-case (top) thermal resistance	79.5	°C/W
R <sub>θJB</sub>	Junction-to-board thermal resistance	33.9	°C/W
ψ <sub>JT</sub>	Junction-to-top characterization parameter	7.8	°C/W
ψ <sub>JB</sub>	Junction-to-board characterization parameter	34.3	°C/W
R <sub>θJC(bot)</sub>	Junction-to-case (bottom) thermal resistance	7.5	°C/W

(1) For more information about traditional and new thermal metrics, see the [Semiconductor and IC Package Thermal Metrics](#) application report.

## 7.5 Electrical Characteristics

Over junction temperature range 0°C ≤ T<sub>J</sub> ≤ 125°C and recommended supply voltage (unless otherwise noted)

PARAMETER		TEST CONDITIONS	MIN	TYP	MAX	UNIT
<b>INPUT</b>						
UVLO	Undervoltage lock-out Exit	V <sub>IN</sub> : 0V → 4V Update based on sim/char	3.15	3.3	3.45	V
V <sub>HYS_UVLO</sub>	Hysteresis on V <sub>UVLO_RISE</sub> falling	V <sub>IN</sub> : 4V → 0V, V <sub>UVLO_FALL</sub> = V <sub>UVLO_RISE</sub> - V <sub>HYS_UVLO</sub>	175	227	280	mV
V <sub>IN-DT</sub>	Input power good detection threshold is V <sub>OUT</sub> + V <sub>IN-DT</sub>	(Input power good if V <sub>IN</sub> > V <sub>OUT</sub> + V <sub>IN-DT</sub> ); V <sub>OUT</sub> = 3.6V, V <sub>IN</sub> : 3.5V → 4V	30	80	145	mV
V <sub>HYS-INDT</sub>	Hysteresis on V <sub>IN-DT</sub> falling	V <sub>OUT</sub> = 3.6V, V <sub>IN</sub> : 4V → 3.5V		31		mV
V <sub>OVP</sub>	Input over-voltage protection threshold	V <sub>IN</sub> : 5V → 12V (BQ24040, BQ24045) V <sub>IN</sub> : 5V → 12V (BQ24041)	6.5	6.65	6.8	V
V <sub>HYS-OVP</sub>	Hysteresis on OVP	V <sub>IN</sub> : 11V → 5V		95		mV
V <sub>IN-DPM</sub>	USB/Adaptor low input voltage protection. Restricts I <sub>OUT</sub> at V <sub>IN-DPM</sub>	Feature active in USB mode; Limit Input Source Current to 50mA; V <sub>OUT</sub> = 3.5V; R <sub>ISET</sub> = 825Ω	4.34	4.4	4.46	V
		Feature active in Adaptor mode; Limit Input Source Current to 50mA; V <sub>OUT</sub> = 3.5V; R <sub>ISET</sub> = 825	4.24	4.3	4.46	
I <sub>IN-USB-CL</sub>	USB input I-Limit 100mA	ISET2 = Float; R <sub>ISET</sub> = 825Ω	85	92	100	mA
	USB input I-Limit 500mA, BQ24040, BQ24045	ISET2 = High; R <sub>ISET</sub> = 825Ω	430	462	500	
	USB input I-Limit 380mA, BQ24041	ISET2 = High; R <sub>ISET</sub> = 825Ω	350	386	420	
<b>ISET SHORT CIRCUIT TEST</b>						
R <sub>ISET_SHORT</sub>	Highest Resistor value considered a fault (short). Monitored for I <sub>OUT</sub> > 90mA	R <sub>ISET</sub> : 540Ω → 250Ω, I <sub>OUT</sub> latches off. Cycle power to Reset.	280		500	Ω
I <sub>OUT_CL</sub>	Maximum OUT current limit Regulation (Clamp)	V <sub>IN</sub> = 5V, V <sub>OUT</sub> = 3.6V, V <sub>ISET2</sub> = Low, R <sub>ISET</sub> : 540Ω → 250Ω, I <sub>OUT</sub> latches off after t <sub>DGL-SHORT</sub>	1.05		1.4	A
<b>BATTERY SHORT PROTECTION</b>						
V <sub>OUT(SC)</sub>	OUT terminal short-circuit detection threshold/ precharge threshold	V <sub>OUT</sub> : 3V → 0.5V, no deglitch	0.75	0.8	0.85	V
V <sub>OUT(SC-HYS)</sub>	OUT terminal Short hysteresis	Recovery ≥ V <sub>OUT(SC)</sub> + V <sub>OUT(SC-HYS)</sub> ; Rising, no Deglitch		77		mV
I <sub>OUT(SC)</sub>	Source current to OUT terminal during short-circuit detection	V <sub>OUT</sub> < 0.8 V	10	15	20	mA
<b>QUIESCENT CURRENT</b>						
I <sub>OUT(PDWN)</sub>	Battery current into OUT terminal	V <sub>IN</sub> = 0V			1	μA
I <sub>OUT(DONE)</sub>	OUT terminal current, charging terminated	V <sub>IN</sub> = 6V, V <sub>OUT</sub> > V <sub>OUT(REG)</sub>			6	
I <sub>IN(STDBY)</sub>	Standby current into IN terminal	TS = LO, V <sub>IN</sub> ≤ 6V			125	μA
I <sub>CC</sub>	Active supply current, IN terminal	TS = open, V <sub>IN</sub> = 6V, TTDM – no load on OUT terminal, V <sub>OUT</sub> > V <sub>OUT(REG)</sub> , IC enabled		0.8	1	mA

## 7.5 Electrical Characteristics (continued)

 Over junction temperature range  $0^{\circ}\text{C} \leq T_J \leq 125^{\circ}\text{C}$  and recommended supply voltage (unless otherwise noted)

PARAMETER		TEST CONDITIONS	MIN	TYP	MAX	UNIT
<b>BATTERY CHARGER FAST-CHARGE</b>						
$V_{\text{OUT(REG)}}$	Battery regulation voltage	$V_{\text{IN}} = 5.5\text{V}$ , $I_{\text{OUT}} = 25\text{mA}$ , ( $V_{\text{TS-45}^{\circ}\text{C}} \leq V_{\text{TS}} \leq V_{\text{TS-0}^{\circ}\text{C}}$ , BQ24040)	4.16	4.2	4.23	V
		$V_{\text{IN}} = 5.5\text{V}$ , $I_{\text{OUT}} = 25\text{mA}$ , ( $V_{\text{TS-45}^{\circ}\text{C}} \leq V_{\text{TS}} \leq V_{\text{TS-0}^{\circ}\text{C}}$ , BQ24045)	4.30	4.35	4.40	
$V_{\text{O-HT(REG)}}$	Battery hot regulation voltage	$V_{\text{IN}} = 5.5\text{V}$ , $I_{\text{OUT}} = 25\text{mA}$ , ( $V_{\text{TS-45}^{\circ}\text{C}} \leq V_{\text{TS}} \leq V_{\text{TS-0}^{\circ}\text{C}}$ , BQ24040)	4.02	4.06	4.1	V
		$V_{\text{IN}} = 5.5\text{V}$ , $I_{\text{OUT}} = 25\text{mA}$ , ( $V_{\text{TS-45}^{\circ}\text{C}} \leq V_{\text{TS}} \leq V_{\text{TS-0}^{\circ}\text{C}}$ , BQ24045)	4.16	4.2	4.23	
$I_{\text{OUT(RANGE)}}$	Programmed Output "fast charge" current range	$V_{\text{OUT(REG)}} > V_{\text{OUT}} > V_{\text{LOWV}}$ ; $V_{\text{IN}} = 5\text{V}$ , ISET2 = LO, $R_{\text{ISET}} = 540$ to $10.8\text{k}\Omega$	10		1000	mA
$V_{\text{DO(IN-OUT)}}$	Drop-Out, $V_{\text{IN}} - V_{\text{OUT}}$	Adjust $V_{\text{IN}}$ down until $I_{\text{OUT}} = 0.5\text{A}$ , $V_{\text{OUT}} = 4.15\text{V}$ , $R_{\text{ISET}} = 540$ , ISET2 = Lo (adaptor mode); $T_J \leq 100^{\circ}\text{C}$		325	500	mV
$I_{\text{OUT}}$	Output "fast charge" formula	$V_{\text{OUT(REG)}} > V_{\text{OUT}} > V_{\text{LOWV}}$ ; $V_{\text{IN}} = 5\text{V}$ , ISET2 = Lo	$K_{\text{ISET}}/R_{\text{ISET}}$			A
$K_{\text{ISET}}$	Fast charge current factor	$R_{\text{ISET}} = K_{\text{ISET}}/I_{\text{OUT}}$ ; $50 < I_{\text{OUT}} < 1000$ mA	510	540	570	A $\Omega$
		$R_{\text{ISET}} = K_{\text{ISET}}/I_{\text{OUT}}$ ; $25 < I_{\text{OUT}} < 50$ mA	480	527	600	
		$R_{\text{ISET}} = K_{\text{ISET}}/I_{\text{OUT}}$ ; $10 < I_{\text{OUT}} < 25$ mA	350	520	680	
$K_{\text{ISET}}$	Fast charge current factor (BQ24045)	$R_{\text{ISET}} = K_{\text{ISET}}/I_{\text{OUT}}$ ; $50 < I_{\text{OUT}} < 1000$ mA	510	560	585	A $\Omega$
		$R_{\text{ISET}} = K_{\text{ISET}}/I_{\text{OUT}}$ ; $25 < I_{\text{OUT}} < 50$ mA	480	557	596	
		$R_{\text{ISET}} = K_{\text{ISET}}/I_{\text{OUT}}$ ; $10 < I_{\text{OUT}} < 25$ mA	350	555	680	
<b>PRECHARGE – SET BY PRETERM terminal: BQ24040 / BQ24045; Internally Set: BQ24041</b>						
$V_{\text{LOWV}}$	Pre-charge to fast-charge transition threshold		2.4	2.5	2.6	V
$I_{\text{PRE-TERM}}$	See the Termination Section					
%PRECHG	Pre-charge current, default setting	$V_{\text{OUT}} < V_{\text{LOWV}}$ ; $R_{\text{ISET}} = 1080\Omega$ ; BQ24040: <b>R<sub>PRE-TERM</sub> = High Z</b> ; BQ24041: Internally Fixed	18	20	22	% $I_{\text{OUT-CC}}$
	Pre-charge current formula	$R_{\text{PRE-TERM}} = K_{\text{PRE-CHG}} (\Omega\%) \times \% \text{PRE-CHG} (\%)$	$R_{\text{PRE-TERM}}/K_{\text{PRE-CHG}}\%$			
$K_{\text{PRE-CHG}}$	% Pre-charge Factor	$V_{\text{OUT}} < V_{\text{LOWV}}$ , $V_{\text{IN}} = 5\text{V}$ , $R_{\text{PRE-TERM}} = 2\text{k}$ to $10\text{k}\Omega$ ; $R_{\text{ISET}} = 1080\Omega$ , $R_{\text{PRE-TERM}} = K_{\text{PRE-CHG}} \times \% \text{FAST-CHG}$ , where %FAST-CHG is 20 to 100%	90	100	110	$\Omega\%$
		$V_{\text{OUT}} < V_{\text{LOWV}}$ , $V_{\text{IN}} = 5\text{V}$ , $R_{\text{PRE-TERM}} = 1\text{k}$ to $2\text{k}\Omega$ ; $R_{\text{ISET}} = 1080\Omega$ , $R_{\text{PRE-TERM}} = K_{\text{PRE-CHG}} \times \% \text{FAST-CHG}$ , where %FAST-CHG is 10% to 20%	84	100	117	$\Omega\%$
<b>TERMINATION – SET BY PRE-TERM terminal: BQ24040 / BQ24045</b>						
%TERM	Termination Threshold Current, default setting	$V_{\text{OUT}} > V_{\text{RCH}}$ ; $R_{\text{ISET}} = 1\text{k}$ ; BQ24040 / BQ24045: <b>R<sub>PRE-TERM</sub> = High Z</b>	9	10	11	% $I_{\text{OUT-CC}}$
	Termination Current Threshold Formula, BQ24040 / BQ24045	$R_{\text{PRE-TERM}} = K_{\text{TERM}} (\Omega\%) \times \% \text{TERM} (\%)$	$R_{\text{PRE-TERM}}/K_{\text{TERM}}$			
$K_{\text{TERM}}$	% Term Factor	$V_{\text{OUT}} > V_{\text{RCH}}$ , $V_{\text{IN}} = 5\text{V}$ , $R_{\text{PRE-TERM}} = 2\text{k}$ to $10\text{k}\Omega$ ; $R_{\text{ISET}} = 750\Omega$ , $K_{\text{TERM}} \times \% \text{FAST-CHG}$ , where %FAST-CHG is 10 to 50%	182	200	216	$\Omega\%$
		$V_{\text{OUT}} > V_{\text{RCH}}$ , $V_{\text{IN}} = 5\text{V}$ , $R_{\text{PRE-TERM}} = 1\text{k}$ to $2\text{k}\Omega$ ; $R_{\text{ISET}} = 750\Omega$ , $K_{\text{TERM}} \times \% \text{Iset}$ , where %Iset is 5 to 10%	174	199	224	
$I_{\text{PRE-TERM}}$	Current for programming the term. and pre-charge with resistor. $I_{\text{Term-Start}}$ is the initial PRE-TERM current.	$R_{\text{PRE-TERM}} = 2\text{k}$ , $V_{\text{OUT}} = 4.15\text{V}$	71	75	81	$\mu\text{A}$
%TERM	Termination current formula		$R_{\text{TERM}}/K_{\text{TERM}}\%$			
$I_{\text{Term-Start}}$	Elevated PRE-TERM current for, $t_{\text{Term-Start}}$ during start of charge to prevent recharge of full battery,		80	85	92	$\mu\text{A}$
<b>RECHARGE OR REFRESH – BQ24040 / BQ24045</b>						
$V_{\text{RCH}}$	Recharge detection threshold – Normal Temp	$V_{\text{IN}} = 5\text{V}$ , $V_{\text{TS}} = 0.5\text{V}$ , $V_{\text{OUT}}: 4.25\text{V} \rightarrow V_{\text{RCH}}$	$V_{\text{O(REG)}}$ -0.120	$V_{\text{O(REG)}}$ -0.095	$V_{\text{O(REG)}}$ 0.070	V
	Recharge detection threshold – Hot Temp	$V_{\text{IN}} = 5\text{V}$ , $V_{\text{TS}} = 0.2\text{V}$ , $V_{\text{OUT}}: 4.15\text{V} \rightarrow V_{\text{RCH}}$	$V_{\text{O-HT(REG)}}$ -0.130	$V_{\text{O-HT(REG)}}$ -0.105	$V_{\text{O-HT(REG)}}$ -0.080	V
<b>BATTERY DETECT ROUTINE – BQ24040 / BQ24045 (NOTE: In Hot mode <math>V_{\text{O(REG)}}</math> becomes <math>V_{\text{O-HT(REG)}}</math>)</b>						
$V_{\text{REG-BD}}$	$V_{\text{OUT}}$ Reduced regulation during battery detect	$V_{\text{IN}} = 5\text{V}$ , $V_{\text{TS}} = 0.5\text{V}$ , Battery Absent	$V_{\text{O(REG)}}$ -0.450	$V_{\text{O(REG)}}$ -0.400	$V_{\text{O(REG)}}$ -350	V
$I_{\text{BD-SINK}}$	Sink current during $V_{\text{REG-BD}}$		6		10	mA
$V_{\text{BD-HI}}$	High battery detection threshold	$V_{\text{IN}} = 5\text{V}$ , $V_{\text{TS}} = 0.5\text{V}$ , Battery Absent	$V_{\text{O(REG)}}$ -0.150	$V_{\text{O(REG)}}$ -0.100	$V_{\text{O(REG)}}$ -0.050	V
$V_{\text{BD-LO}}$	Low battery detection threshold	$V_{\text{IN}} = 5\text{V}$ , $V_{\text{TS}} = 0.5\text{V}$ , Battery Absent	$V_{\text{REG-BD}}$ +0.50	$V_{\text{REG-BD}}$ +0.1	$V_{\text{REG-BD}}$ +0.15	V

## 7.5 Electrical Characteristics (continued)

Over junction temperature range  $0^{\circ}\text{C} \leq T_J \leq 125^{\circ}\text{C}$  and recommended supply voltage (unless otherwise noted)

PARAMETER		TEST CONDITIONS	MIN	TYP	MAX	UNIT
<b>BATTERY-PACK NTC MONITOR; TS Terminal: BQ24040 / BQ24045: 10k NTC</b>						
I <sub>NTC-10k</sub>	NTC bias current	V <sub>TS</sub> = 0.3V	48	50	52	μA
I <sub>NTC-DIS-10k</sub>	10k NTC bias current when Charging is disabled.	V <sub>TS</sub> = 0V	27	30	34	μA
I <sub>NTC-FLDBK-10k</sub>	INTC is reduced prior to entering TTDM to keep cold thermistor from entering TTDM	V <sub>TS</sub> : Set to 1.525V	4	5	6.5	μA
V <sub>TTDM(TS)</sub>	Termination and timer disable mode Threshold – Enter	V <sub>TS</sub> : 0.5V → 1.7V; Timer Held in Reset	1550	1600	1650	mV
V <sub>HYS-TTDM(TS)</sub>	Hysteresis exiting TTDM	V <sub>TS</sub> : 1.7V → 0.5V; Timer Enabled		100		mV
V <sub>CLAMP(TS)</sub>	TS maximum voltage clamp	V <sub>TS</sub> = Open (Float)	1800	1950	2000	mV
V <sub>TS-1-FLDBK</sub>	TS voltage where INTC is reduce to keep thermistor from entering TTDM	INTC adjustment (90 to 10%; 45 to 6.6μs) takes place near this spec threshold. V <sub>TS</sub> : 1.425V → 1.525V		1475		mV
C <sub>TS</sub>	Optional Capacitance – ESD			0.22		μF
V <sub>TS-0°C</sub>	Low temperature CHG Pending	Low Temp Charging to Pending; V <sub>TS</sub> : 1V → 1.5V	1205	1230	1255	mV
V <sub>HYS-0°C</sub>	Hysteresis at 0°C	Charge pending to low temp charging; V <sub>TS</sub> : 1.5V → 1V		86		mV
V <sub>TS-10°C</sub>	Low temperature, half charge	Normal charging to low temp charging; V <sub>TS</sub> : 0.5V → 1V	765	790	815	mV
V <sub>HYS-10°C</sub>	Hysteresis at 10°C	Low temp charging to normal CHG; V <sub>TS</sub> : 1V → 0.5V		35		mV
V <sub>TS-45°C</sub>	High temperature at 4.1V	Normal charging to high temp CHG; V <sub>TS</sub> : 0.5V → 0.2V	263	278	293	mV
V <sub>HYS-45°C</sub>	Hysteresis at 45°C	High temp charging to normal CHG; V <sub>TS</sub> : 0.2V → 0.5V		10.7		mV
V <sub>TS-60°C</sub>	High temperature Disable	High temp charge to pending; V <sub>TS</sub> : 0.2V → 0.1V	170	178	186	mV
V <sub>HYS-60°C</sub>	Hysteresis at 60°C	Charge pending to high temp CHG; V <sub>TS</sub> : 0.1V → 0.2V		11.5		mV
V <sub>TS-EN-10k</sub>	Charge Enable Threshold, (10k NTC)	V <sub>TS</sub> : 0V → 0.175V	80	88	96	mV
V <sub>TS-DIS_HYS-10k</sub>	HYS below V <sub>TS-EN-10k</sub> to Disable, (10k NTC)	V <sub>TS</sub> : 0.125V → 0V		12		mV
<b>THERMAL REGULATION</b>						
T <sub>J(REG)</sub>	Temperature regulation limit			125		°C
T <sub>J(OFF)</sub>	Thermal shutdown temperature			155		°C
T <sub>J(OFF-HYS)</sub>	Thermal shutdown hysteresis			20		°C
<b>BAT_EN , BQ24041</b>						
I <sub>BAT_EN</sub>	Current Sourced out of terminal	V <sub>BAT_EN</sub> < 1.4 V	2.3	5	9	μA
V <sub>IL</sub>	Logic LOW enables charger		0		0.4	V
V <sub>IH</sub>	Logic HIGH disables charger		1.1		6	V
V <sub>CLAMP</sub>	Floating Clamp Voltage	Floating BAT_EN terminal	1.4	1.6	1.8	V
<b>LOGIC LEVELS ON ISET2</b>						
V <sub>IL</sub>	Logic LOW input voltage	Sink 8 μA			0.4	V
V <sub>IH</sub>	Logic HIGH input voltage	Source 8 μA	1.4			V
I <sub>IL</sub>	Sink current required for LO	V <sub>ISET2</sub> = 0.4V	2		9	μA
I <sub>IH</sub>	Source current required for HI	V <sub>ISET2</sub> = 1.4V	1.1		9.5	μA
V <sub>FLT</sub>	ISET2 Float Voltage		575	900	1225	mV
<b>AUTO START, ASI AND ASO TERMINALS, BQ24041</b>						
V <sub>ASIL</sub>	Has 200k Internal Pull-down				0.4	V
V <sub>ASIH</sub>			1.3			V
V <sub>ASOL</sub>	Auto Start Output Sinks 1mA				0.4	V
V <sub>ASOH</sub>	Auto Start Input Sources 1mA		V <sub>OUT</sub> - 0.4			V
<b>LOGIC LEVELS ON CHG AND PG</b>						
V <sub>OL</sub>	Output LOW voltage	I <sub>SINK</sub> = 5 mA			0.4	V
I <sub>LEAK</sub>	Leakage current into IC	V <sub>CHG</sub> = 5V, V <sub>PG</sub> = 5V			1	μA

## 7.6 Timing Requirements

			MIN	NOM	MAX	UNIT
<b>INPUT</b>						
$t_{DGL(PG\_PWR)}$	Deglitch time on exiting sleep.	Time measured from $V_{IN}$ : 0V → 5V 1 $\mu$ s rise-time to $\overline{PG}$ = low, $V_{OUT}$ = 3.6V		45		$\mu$ s
$t_{DGL(PG\_NO\_PWR)}$	Deglitch time on $V_{HYS\_INDT}$ power down. Same as entering sleep.	Time measured from $V_{IN}$ : 5V → 3.2V 1 $\mu$ s fall-time to $\overline{PG}$ = OC, $V_{OUT}$ = 3.6V		29		ms
$t_{DGL(OVP\_SET)}$	Input over-voltage blanking time	$V_{IN}$ : 5V → 12V		113		$\mu$ s
$t_{DGL(OVP\_REC)}$	Deglitch time exiting OVP	Time measured from $V_{IN}$ : 12V → 5V 1 $\mu$ s fall-time to $\overline{PG}$ = LO		30		$\mu$ s
<b>ISET SHORT CIRCUIT TEST</b>						
$t_{DGL\_SHORT}$	Deglitch time transition from ISET short to $I_{OUT}$ disable	Clear fault by disconnecting IN or cycling (high / low) TS/ $\overline{BAT\_EN}$		1		ms
<b>PRECHARGE – SET BY PRETERM PIN: BQ24040 / BQ24045; Internally Set: BQ24041</b>						
$t_{DGL1(LOWV)}$	Deglitch time on pre-charge to fast-charge transition			70		$\mu$ s
$t_{DGL2(LOWV)}$	Deglitch time on fast-charge to pre-charge transition			32		ms
<b>TERMINATION – SET BY PRE-TERM PIN: BQ24040 / BQ24045</b>						
$t_{DGL(TERM)}$	Deglitch time, termination detected			29		ms
$t_{Term-Start}$	Elevated termination threshold initially active for $t_{Term-Start}$			1.25		min
<b>RECHARGE OR REFRESH – BQ24040 / BQ24045</b>						
$t_{DGL1(RCH)}$	Deglitch time, recharge threshold detected	$V_{IN}$ = 5V, $V_{TS}$ = 0.5V, $V_{OUT}$ : 4.25V → 3.5V in 1 $\mu$ s; $t_{DGL(RCH)}$ is time to ISET ramp		29		ms
$t_{DGL2(RCH)}$	Deglitch time, recharge threshold detected in OUT-Detect Mode	$V_{IN}$ = 5V, $V_{TS}$ = 0.5V, $V_{OUT}$ = 3.5V inserted; $t_{DGL(RCH)}$ is time to ISET ramp		3.6		ms
<b>BATTERY DETECT ROUTINE – BQ24040 / BQ24045 (NOTE: In Hot mode <math>V_{O(REG)}</math> becomes <math>V_{O\_HT(REG)}</math>)</b>						
$t_{DGL(HI/LOW REG)}$	Regulation time at $V_{REG}$ or $V_{REG-BD}$			25		ms
<b>BATTERY CHARGING TIMERS AND FAULT TIMERS: BQ24040 and BQ24045 only</b>						
$t_{PRECHG}$	Pre-charge safety timer value	Restarts when entering Pre-charge; Always enabled when in pre-charge.	1700	1940	2250	s
$t_{MAXCH}$	Charge safety timer value	Clears fault or resets at UVLO, TS/ $\overline{BAT\_EN}$ disable, OUT Short, exiting LOWV and Refresh	34000	38800	45000	s
<b>BATTERY-PACK NTC MONITOR; TS Terminal: BQ24040 / BQ24045: 10k NTC</b>						
$t_{DGL(TTDM)}$	Deglitch exit TTDM between states			57		ms
	Deglitch enter TTDM between states			8		$\mu$ s
$t_{DGL(TS\_10C)}$	Deglitch for TS thresholds: 10C.	Normal to Cold Operation; $V_{TS}$ : 0.6V → 1V		50		ms
		Cold to Normal Operation; $V_{TS}$ : 1V → 0.6V		12		ms
$t_{DGL(TS)}$	Deglitch for TS thresholds: 0/45/60C.	Battery charging		30		ms

## 7.7 Typical Operational Characteristics (Protection Circuits Waveforms)

SETUP: BQ24040 typical applications schematic;  $V_{IN} = 5V$ ,  $V_{BAT} = 3.6V$  (unless otherwise indicated)

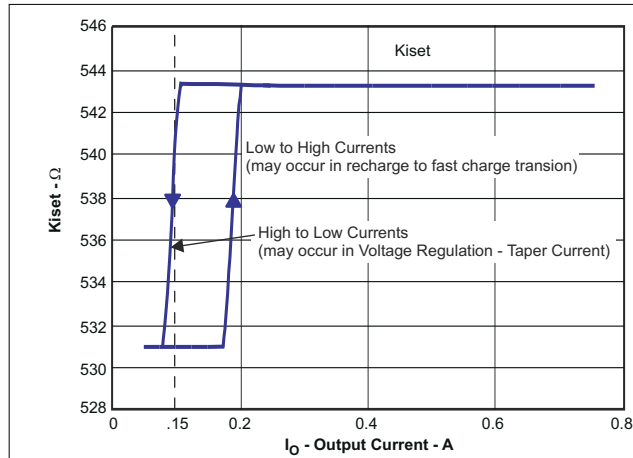


Figure 7-1. Kiset for Low and High Currents

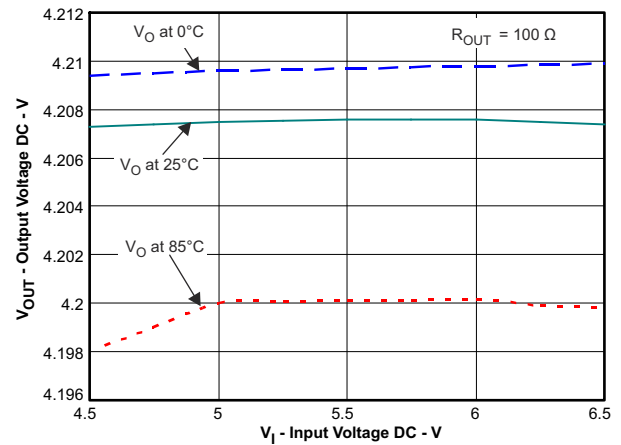


Figure 7-2. Line Regulation

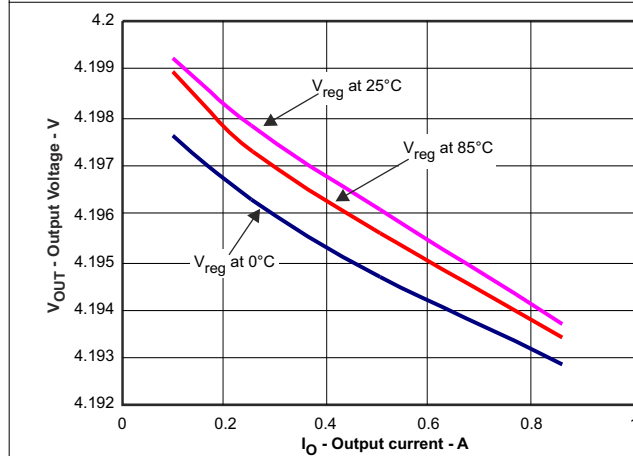


Figure 7-3. Load Regulation Over Temperature

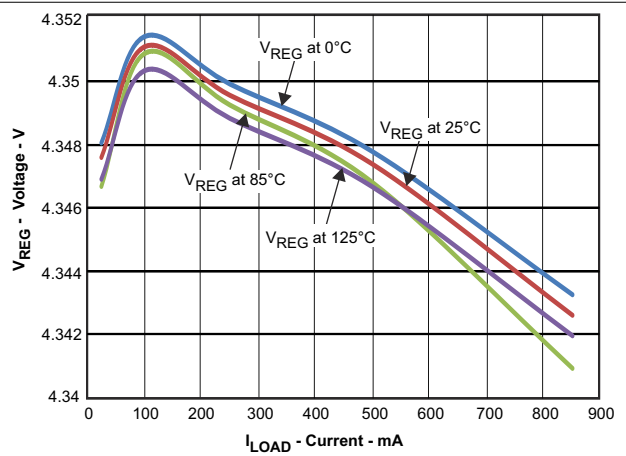


Figure 7-4. Load Regulation

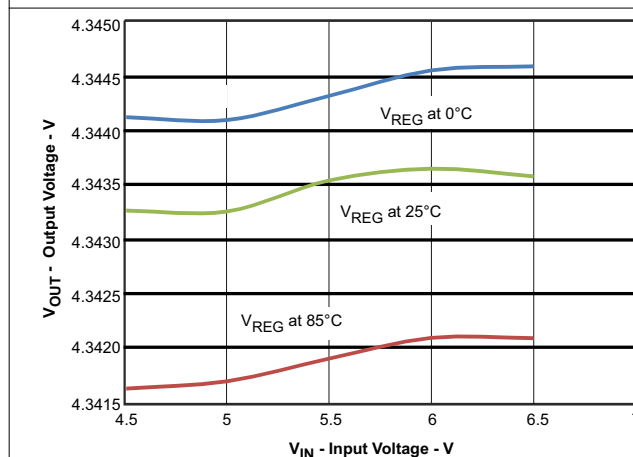


Figure 7-5. Line Regulation

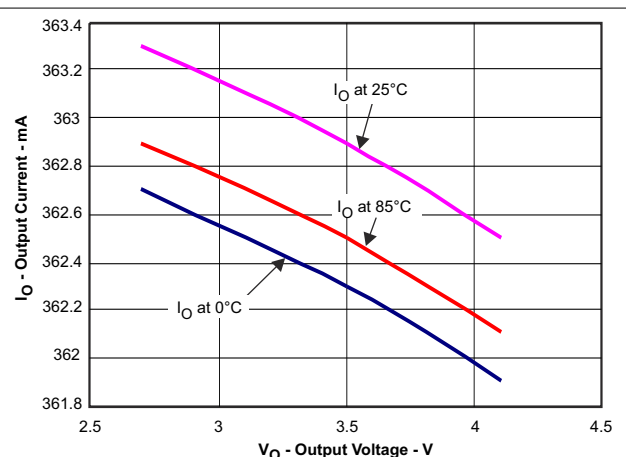


Figure 7-6. Current Regulation Over Temperature

## 8 Detailed Description

### 8.1 Overview

The BQ2404x is a highly integrated family of 2×2 single cell Li-Ion and Li-Pol chargers. The charger can be used to charge a battery, power a system or both. The charger has three phases of charging: Pre-charge to recover a fully discharged battery, fast-charge constant current to supply the buck charge safely and voltage regulation to safely reach full capacity. The charger is very flexible, allowing programming of the fast-charge current and Pre-charge/Termination Current (BQ24040/5 only). This charger is designed to work with a USB connection or Adaptor (DC out). The charger also checks to see if a battery is present.

The charger also comes with a full set of safety features: JEITA Temperature Standard (BQ24040/5 only), Over-Voltage Protection, DPM-IN, Safety Timers, and ISET short protection. All of these features and more are described in detail below.

The charger is designed for a single power path from the input to the output to charge a single cell Li-Ion or Li-Pol battery pack. Upon application of a 5VDC power source the ISET and OUT short checks are performed to assure a proper charge cycle.

If the battery voltage is below the LOWV threshold, the battery is considered discharged and a preconditioning cycle begins. The amount of precharge current can be programmed using the PRE-TERM terminal which programs a percent of fast charge current (10 to 100%) as the precharge current. This feature is useful when the system load is connected across the battery "stealing" the battery current. The precharge current can be set higher to account for the system loading while allowing the battery to be properly conditioned. The PRE-TERM terminal is a dual function terminal which sets the precharge current level and the termination threshold level. The termination "current threshold" is always half of the precharge programmed current level.

Once the battery voltage has charged to the VLOWV threshold, fast charge is initiated and the fast charge current is applied. The fast charge constant current is programmed using the ISET terminal. The constant current provides the bulk of the charge. Power dissipation in the IC is greatest in fast charge with a lower battery voltage. If the IC reaches 125°C the IC enters thermal regulation, slows the timer clock by half and reduce the charge current as needed to keep the temperature from rising any further. [Figure 8-1](#) shows the charging profile with thermal regulation. Typically under normal operating conditions, the IC's junction temperature is less than 125°C and thermal regulation is not entered.

Once the cell has charged to the regulation voltage the voltage loop takes control and holds the battery at the regulation voltage until the current tapers to the termination threshold. The termination can be disabled if desired. The  $\overline{\text{CHG}}$  terminal is low (LED on) during the first charge cycle only and turns off once the termination threshold is reached, regardless if termination, for charge current, is enabled or disabled.

Further details are mentioned in the Operating Modes section.



## 8.3 Feature Description

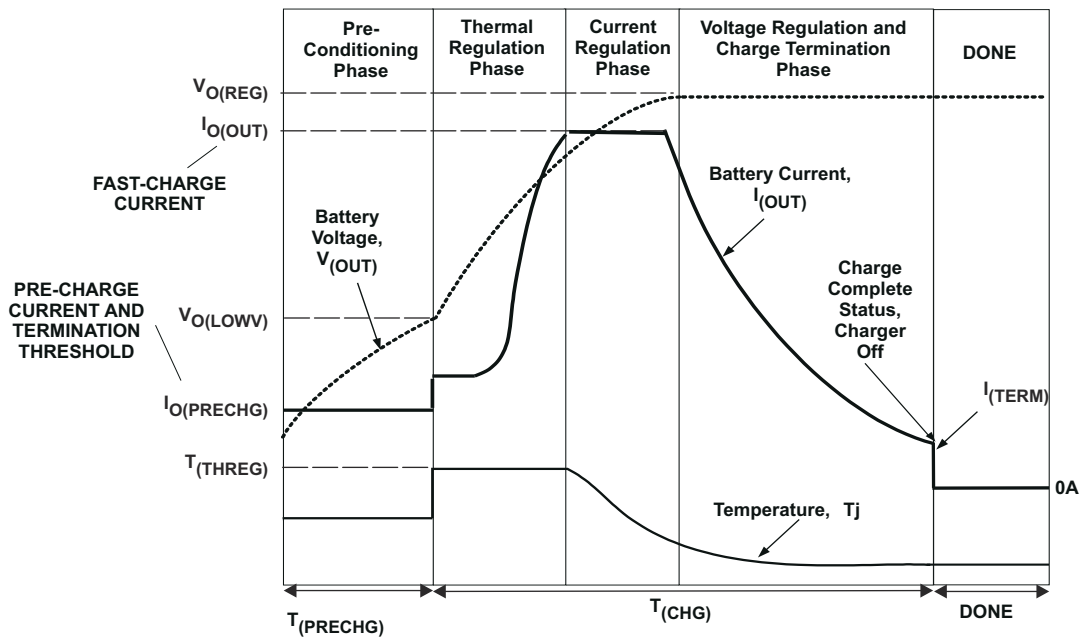


Figure 8-1. Charging Profile With Thermal Regulation

### 8.3.1 Power-Down or Undervoltage Lockout (UVLO)

The BQ2404x family is in power down mode if the IN terminal voltage is less than UVLO. The part is considered “dead” and all the terminals are high impedance. Once the IN voltage rises above the UVLO threshold the IC will enter Sleep Mode or Active mode depending on the OUT terminal (battery) voltage.

### 8.3.2 Power-up

The IC is alive after the IN voltage ramps above UVLO (see sleep mode), resets all logic and timers, and starts to perform many of the continuous monitoring routines. Typically the input voltage quickly rises through the UVLO and sleep states where the IC declares power good, starts the qualification charge at 100mA, sets the input current limit threshold base on the ISET2 terminal, starts the safety timer and enables the  $\overline{CHG}$  terminal. See [Figure 8-2](#).

### 8.3.3 Sleep Mode

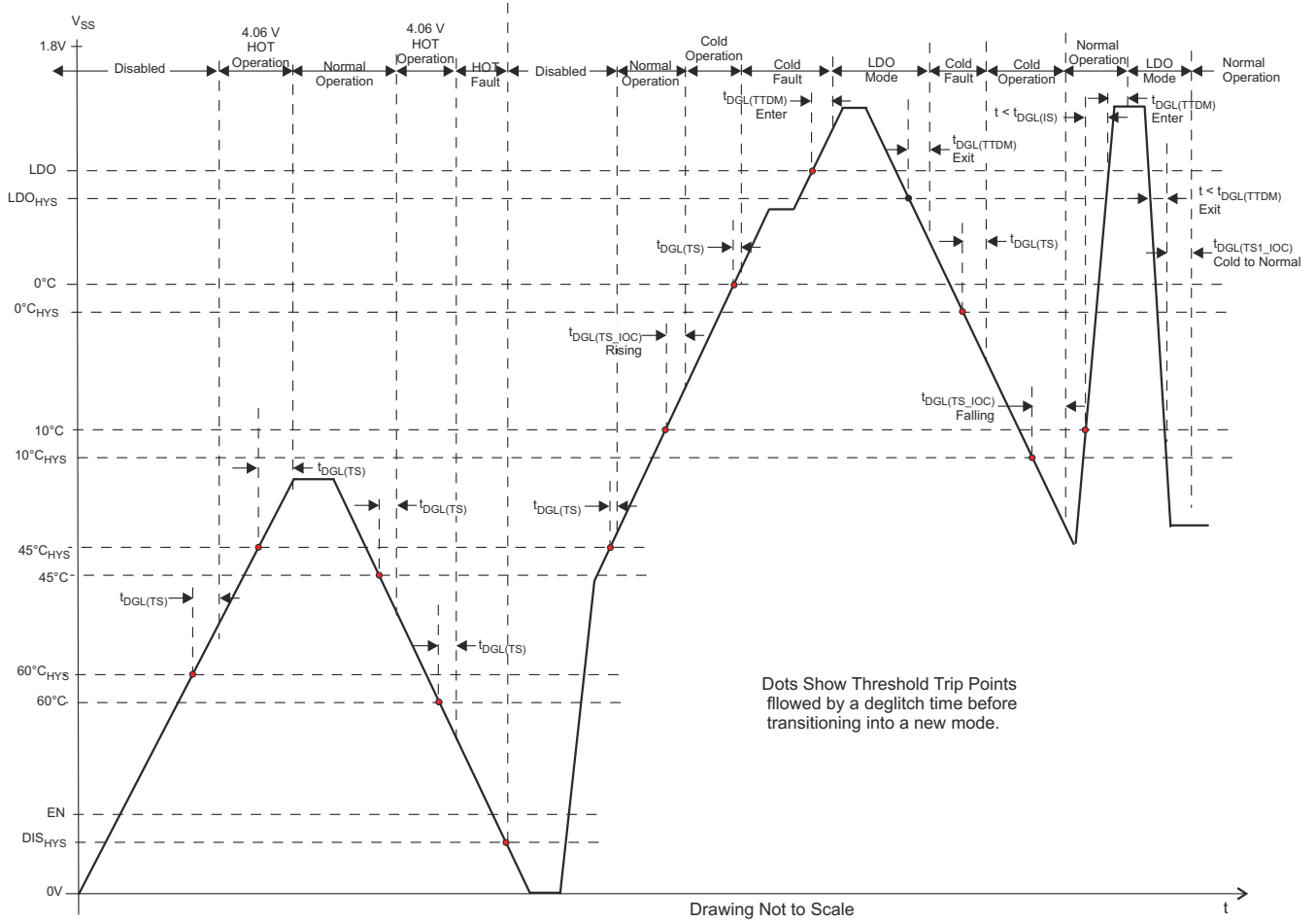
If the IN terminal voltage is between than  $V_{OUT} + V_{DT}$  and UVLO, the charge current is disabled, the safety timer counting stops (not reset) and the  $\overline{PG}$  and  $\overline{CHG}$  terminals are high impedance. As the input voltage rises and the charger exits sleep mode, the  $\overline{PG}$  terminal goes low, the safety timer continues to count, charge is enabled and the  $\overline{CHG}$  terminal returns to its previous state. See [Figure 8-3](#).

### 8.3.4 New Charge Cycle

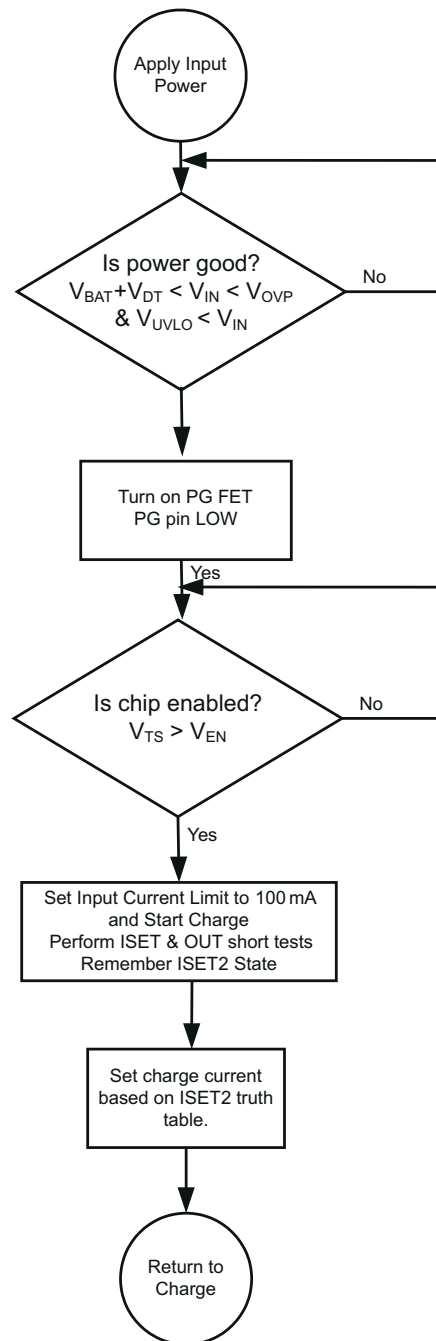
A new charge cycle is started when any of these events occur:

- A valid power source is applied;
- The chip is enabled/disabled using TS pin or BAT\_EN;
- Exit of termination/Timer Disable Mode (TTDM);
- Detection of batter insertion;
- OUT voltage drops below the VRCH threshold.

The  $\overline{CHG}$  signal is active only during the first charge cycle. Exiting TTDM or the OUT voltage falling below VRCH will not activate the  $\overline{CHG}$  signal if it is already in the open-drain (off) state.



**Figure 8-2. TS Battery Temperature Bias Threshold and Deglitch Timers**



**Figure 8-3. BQ2404x Power-Up Flow Diagram**

### 8.3.5 Overvoltage-Protection (OVP) – Continuously Monitored

If the input source applies an overvoltage, the pass FET, if previously on, turns off after a deglitch,  $t_{BLK(OVP)}$ . The timer ends and the  $\overline{CHG}$  and  $\overline{PG}$  terminal goes to a high impedance state. Once the overvoltage returns to a normal voltage, the  $\overline{PG}$  terminal goes low, timer continues, charge continues and the  $\overline{CHG}$  terminal goes low after a 25ms deglitch. PG terminal is optional on some packages

### 8.3.6 Power Good Indication ( $\overline{PG}$ )

After application of a 5V source, the input voltage rises above the UVLO and sleep thresholds ( $V_{IN} > V_{BAT} + V_{DT}$ ), but is less than OVP ( $V_{IN} < V_{OVP}$ ), then the PG FET turns on and provides a low impedance path to ground. See [Figure 9-6](#), [Figure 9-7](#), and [Figure 9-19](#).

### 8.3.7 $\overline{\text{CHG}}$ Terminal Indication

The charge terminal has an internal open drain FET which is on (pulls down to  $V_{SS}$ ) during the first charge only (independent of TTDM) and is turned off once the battery reaches voltage regulation and the charge current tapers to the termination threshold set by the PRE-TERM resistor. The BQ24041 does not terminate charge, however, the  $\overline{\text{CHG}}$  terminal will turn off once the battery current reaches 10% of the programmed charge current.

The charge terminal is high impedance in sleep mode and OVP (if  $\overline{\text{PG}}$  is high impedance) and return to its previous state once the condition is removed.

Cycling input power, pulling the TS terminal low and releasing or entering pre-charge mode causes the  $\overline{\text{CHG}}$  terminal to go reset (go low if power is good and a discharged battery is attached) and is considered the start of a first charge.

## 8.4 Device Functional Modes

### 8.4.1 $\overline{\text{CHG}}$ and $\overline{\text{PG}}$ LED Pull-up Source

For host monitoring, a pullup resistor is used between the STATUS terminal and the  $V_{CC}$  of the host and for a visual indication a resistor in series with an LED is connected between the STATUS terminal and a power source. If the  $\overline{\text{CHG}}$  or  $\overline{\text{PG}}$  source is capable of exceeding 7V, a 6.2V Zener should be used to clamp the voltage. If the source is the OUT terminal, note that as the battery changes voltage, and the brightness of the LEDs vary.

**Table 8-1.**

CHARGING STATE	CHG FET/LED
First charge after VIN applied	ON
Refresh charge	OFF
OVP	
SLEEP	
TEMP FAULT	ON for 1st Charge

**Table 8-2.**

V <sub>IN</sub> POWER GOOD STATE	PG FET/LED
UVLO	OFF
SLEEP mode	
OVP mode	
Normal input ( $V_{OUT} + V_{DT} < V_{IN} < V_{OUP}$ )	ON
PG is independent of chip disable	

### 8.4.2 Auto Start-up (BQ24041)

The auto start-up feature is an OR gate with two inputs; an internal power good signal (logic 1 when  $V_{IN} > V_{BAT} + V_{IN-DT}$ ) and an external input from ASI terminal (internal 100kΩ pull-down). The ASO terminal outputs a signal that can be used as a system boot signal. The OR gate is powered by the OUT terminal and the OUT terminal must be powered by an external source (battery or P/S) or via the IN terminal for the ASO terminal to deliver a logic High. The ASI and/or the internal power good signal have to be logic high for the ASO to be logic high. The ASI/ASO, OUT and PG signals are used in production testing to test the system without a battery.

### 8.4.3 IN-DPM (V<sub>IN</sub>-DPM or IN-DPM)

The IN-DPM feature is used to detect an input source voltage that is folding back (voltage dropping), reaching its current limit due to excessive load. When the input voltage drops to the  $V_{IN-DPM}$  threshold the internal pass FET starts to reduce the current until there is no further drop in voltage at the input. This would prevent a source with voltage less than  $V_{IN-DPM}$  to power the out terminal. This works well with current limited adaptors and USB ports as long as the nominal voltage is above 4.3V and 4.4V respectively. This is an added safety feature that helps protect the source from excessive loads.

### 8.4.4 OUT

The Charger's OUT terminal provides current to the battery and to the system, if present. This IC can be used to charge the battery plus power the system, charge just the battery or just power the system (TTDM) assuming the loads do not exceed the available current. The OUT terminal is a current limited source and is inherently protected against shorts. If the system load ever exceeds the output programmed current threshold, the output will be discharged unless there is sufficient capacitance or a charged battery present to supplement the excessive load.

### 8.4.5 ISET

An external resistor is used to Program the Output Current (50 to 1000mA) and can be used as a current monitor.

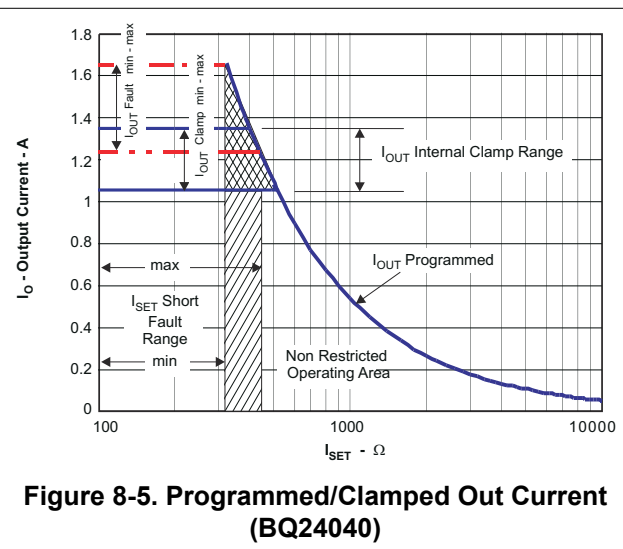
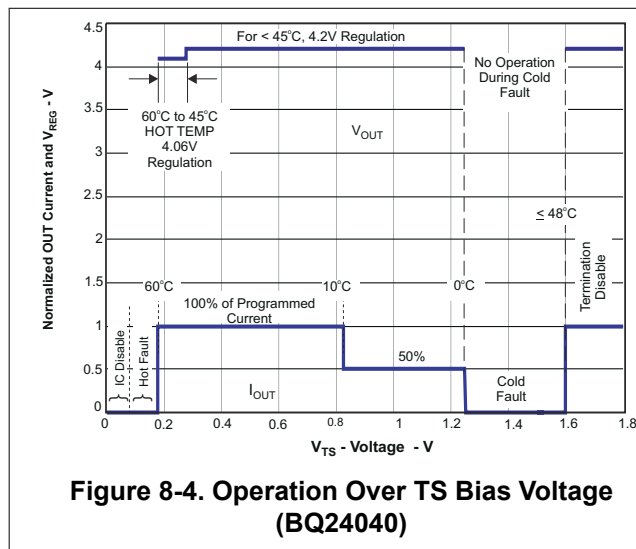
$$R_{ISET} = K_{ISET} / I_{OUT} \quad (1)$$

where

- $I_{OUT}$  is the desired fast charge current;
- $K_{ISET}$  is a gain factor found in the electrical specification

For greater accuracy at lower currents, part of the sense FET is disabled to give better resolution. Figure 7-1 shows the transition from low current to higher current. Going from higher currents to low currents, there is hysteresis and the transition occurs around 0.15A.

The ISET resistor is short protected and will detect a resistance lower than  $\approx 340\Omega$ . The detection requires at least 80mA of output current. If a "short" is detected, then the IC will latch off and can only be reset by cycling the power. The OUT current is internally clamped to a maximum current between 1.05A and 1.4A and is independent of the ISET short detection circuitry, as shown in Figure 8-5. Also, see Figure 9-14 and Figure 9-15.



### 8.4.6 PRE\_TERM – Pre-Charge and Termination Programmable Threshold, BQ24040/5

Pre-Term is used to program both the pre-charge current and the termination current threshold. The pre-charge current level is a factor of two higher than the termination current level. The termination can be set between 5 and 50% of the programmed output current level set by ISET. If left floating the termination and pre-charge are set internally at 10/20% respectively. The pre-charge-to-fast-charge,  $V_{lowv}$  threshold is set to 2.5V.

$$R_{PRE-TERM} = \%Term \times K_{TERM} = \%Pre-CHG \times K_{PRE-CHG} \quad (2)$$

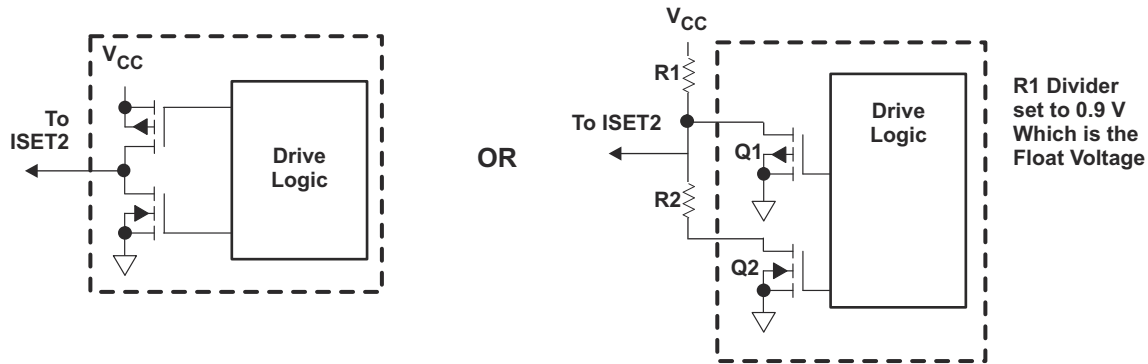
where

- %Term is the percent of fast charge current where termination occurs;
- %Pre-CHG is the percent of fast charge current that is desired during precharge;
- $K_{TERM}$  and  $K_{PRE-CHG}$  are gain factors found in the electrical specifications.

### 8.4.7 ISET2

ISET2 is a 3-state input and programs the Input Current Limit/Regulation Threshold. A low will program a regulated fast charge current via the ISET resistor and is the maximum allowed input/output current for any ISET2 setting, Float will program a 100mA Current limit and High will program a 500mA Current limit.

Below are two configurations for driving the 3-state ISET2 terminal:



**Figure 8-6. 3-State ISET2 Terminal Circuits**

### 8.4.8 TS (BQ24040/5)

The TS function for the BQ24040/5 is designed to follow the new JEITA temperature standard for Li-Ion and Li-Pol batteries. There are now four thresholds, 60°C, 45°C, 10°C, and 0°C. Normal operation occurs between 10°C and 45°C. If between 0°C and 10°C the charge current level is cut in half and if between 45°C and 60°C the regulation voltage is reduced to 4.1V<sub>max</sub>, see [Figure 8-4](#).

The TS feature is implemented using an internal 50µA current source to bias the thermistor (designed for use with a 10k NTC  $\beta = 3370$  (SEMITEC 103AT-2 or Mitsubishi TH05-3H103F) connected from the TS terminal to V<sub>SS</sub>. If this feature is not needed, a fixed 10kΩ can be placed between TS and V<sub>SS</sub> to allow normal operation. This may be done if the host is monitoring the thermistor and then the host would determine when to pull the TS terminal low to disable charge.

The TS terminal has two additional features, when the TS terminal is pulled low or floated/driven high. A low disables charge (similar to a high on the  $\overline{BAT\_EN}$  feature) and a high puts the charger in TTDM.

Above 60°C or below 0°C the charge is disabled. Once the thermistor reaches  $\neq -10^\circ\text{C}$  the TS current folds back to keep a cold thermistor (between  $-10^\circ\text{C}$  and  $-50^\circ\text{C}$ ) from placing the IC in the TTDM mode. If the TS terminal is pulled low into disable mode, the current is reduce to  $\neq 30\mu\text{A}$ , see [Figure 8-2](#). Since the I<sub>TS</sub> current is fixed along with the temperature thresholds, it is not possible to use thermistor values other than the 10k NTC (at 25°C).

#### 8.4.9 Termination and Timer Disable Mode (TTDM) - TS Terminal High

The battery charger is in TTDM when the TS terminal goes high from removing the thermistor (removing battery pack/floating the TS terminal) or by pulling the TS terminal up to the TTDM threshold.

When entering TTDM, the 10 hour safety timer is held in reset and termination is disabled. A battery detect routine is run to see if the battery was removed or not. If the battery was removed then the  $\overline{\text{CHG}}$  terminal will go to its high impedance state if not already there. If a battery is detected the  $\overline{\text{CHG}}$  terminal does not change states until the current tapers to the termination threshold, where the  $\overline{\text{CHG}}$  terminal goes to its high impedance state if not already there (the regulated output will remain on).

The charging profile does not change (still has pre-charge, fast-charge constant current and constant voltage modes). This implies the battery is still charged safely and the current is allowed to taper to zero.

When coming out of TTDM, the battery detect routine is run and if a battery is detected, then a new charge cycle begins and the  $\overline{\text{CHG}}$  LED turns on.

If TTDM is not desired upon removing the battery with the thermistor, one can add a 237k resistor between TS and  $V_{SS}$  to disable TTDM. This keeps the current source from driving the TS terminal into TTDM. This creates  $\pm 0.1^{\circ}\text{C}$  error at hot and a  $\pm 3^{\circ}\text{C}$  error at cold.

#### 8.4.10 Timers, BQ24040 and BQ24045 only

The pre-charge timer is set to 30 minutes. The pre-charge current, can be programmed to off-set any system load, making sure that the 30 minutes is adequate. The BQ24041 does not have a safety timer.

The fast charge timer is fixed at 10 hours and can be increased real time by going into thermal regulation, IN-DPM or if in USB current limit. The timer clock slows by a factor of 2, resulting in a clock that counts half as fast when in these modes. If either the 30 minute or ten hour timer times out, the charging is terminated and the  $\overline{\text{CHG}}$  terminal goes high impedance if not already in that state. The timer is reset by disabling the IC, cycling power or going into and out of TTDM.

#### 8.4.11 Termination

Once the OUT terminal goes above  $V_{RCH}$ , (reaches voltage regulation) and the current tapers down to the termination threshold, the  $\overline{\text{CHG}}$  terminal goes high impedance and a battery detect routine is run to determine if the battery was removed or the battery is full. If the battery is present, the charge current will terminate. If the battery was removed along with the thermistor, then the TS terminal is driven high and the charge enters TTDM. If the battery was removed and the TS terminal is held in the active region, then the battery detect routine will continue until a battery is inserted.

#### 8.4.12 Battery Detect Routine

The battery detect routine should check for a missing battery while keeping the OUT terminal at a useable voltage. Whenever the battery is missing the  $\overline{\text{CHG}}$  terminal should be high impedance.

The battery detect routine is run when entering and exiting TTDM to verify if battery is present, or run all the time if battery is missing and not in TTDM. On power-up, if battery voltage is greater than  $V_{RCH}$  threshold, a battery detect routine is run to determine if a battery is present.

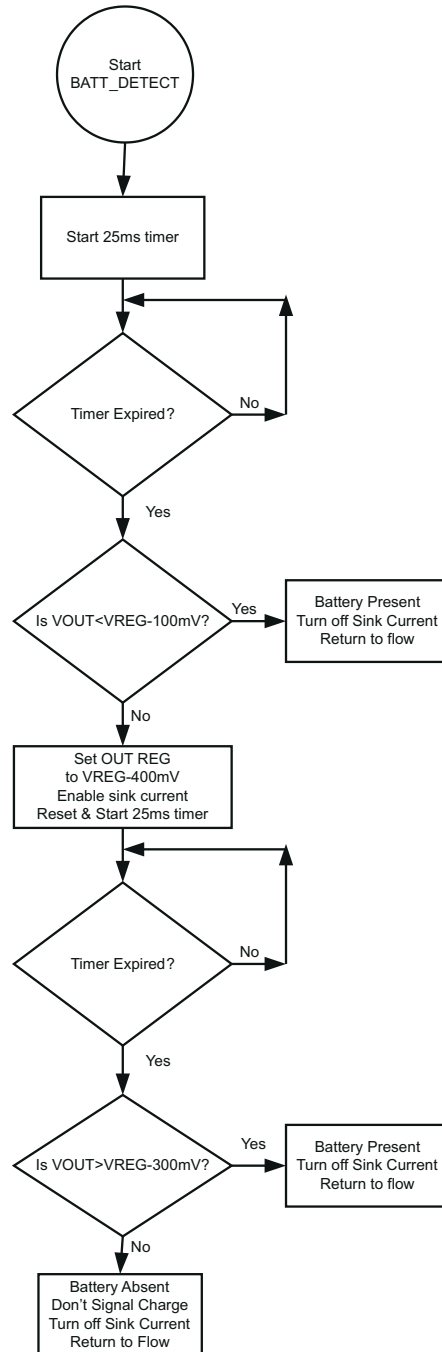
The battery detect routine is disabled while the IC is in TTDM, or has a TS fault. See [Figure 8-7](#) for the Battery Detect Flow Diagram.

#### 8.4.13 Refresh Threshold

After termination, if the OUT terminal voltage drops to  $V_{RCH}$  (100mV below regulation) then a new charge is initiated, but the  $\overline{\text{CHG}}$  terminal remains at a high impedance (off).

#### 8.4.14 Starting a Charge on a Full Battery

The termination threshold is raised by  $\pm 14\%$ , for the first minute of a charge cycle so if a full battery is removed and reinserted or a new charge cycle is initiated, that the new charge terminates (less than 1 minute). Batteries that have relaxed many hours may take several minutes to taper to the termination threshold and terminate charge.



**Figure 8-7. Battery Detect Routine (BQ24040)**

## 9 Application and Implementation

### Note

Information in the following applications sections is not part of the TI component specification, and TI does not warrant its accuracy or completeness. TI's customers are responsible for determining suitability of components for their purposes. Customers should validate and test their design implementation to confirm system functionality.

### 9.1 Application Information

The BQ2404x series of devices are highly integrated Li-Ion and Li-Pol linear chargers devices targeted at space-limited portable applications. The devices operate from either a USB port or AC adaptor. The high input voltage range with input overvoltage protection supports low-cost unregulated adapters. These devices have a single power output that charges the battery. A system load can be placed in parallel with the battery as long as the average system load does not keep the battery from charging fully during the 10 hour safety timer.

### 9.2 Typical Applications

#### 9.2.1 Typical Application: BQ24040 and BQ24045

$I_{OUT\_FAST\_CHG} = 540\text{mA}$ ;  $I_{OUT\_PRE\_CHG} = 108\text{mA}$ ;  $I_{OUT\_TERM} = 54\text{mA}$

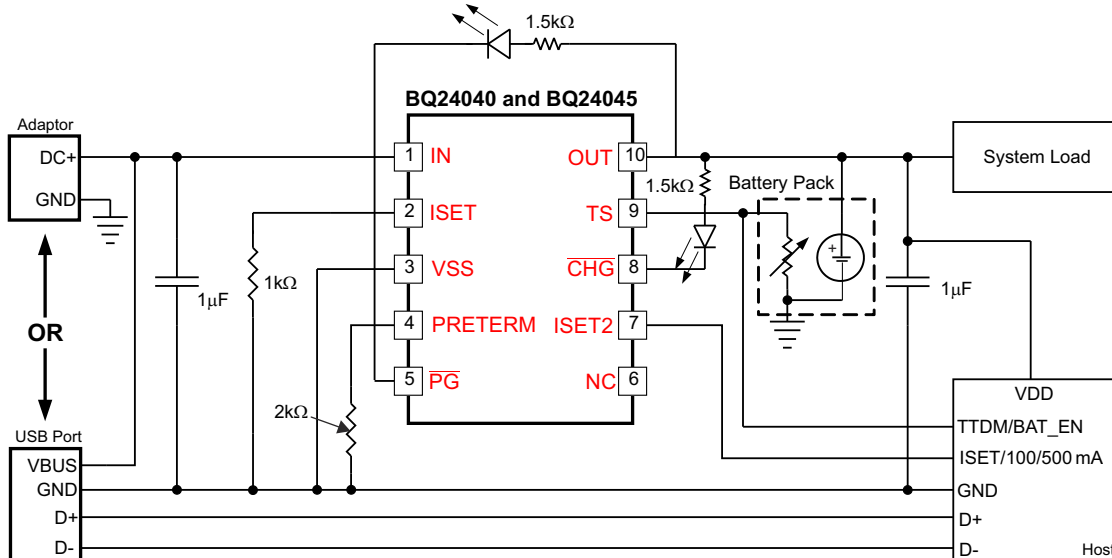


Figure 9-1. Typical Application Circuit: BQ24040 and BQ24045

#### 9.2.1.1 Design Requirements

- Supply voltage = 5 V
- Fast charge current:  $I_{OUT\_FC} = 540\text{ mA}$ ; ISET-terminal 2
- Termination Current Threshold:  $\%I_{OUT\_FC} = 10\%$  of Fast Charge or about 54mA
- Pre-Charge Current by default is twice the termination Current or about 108mA
- TS – Battery Temperature Sense = 10k NTC (103AT)

### 9.2.1.2 Detailed Design Procedure

#### 9.2.1.2.1 Calculations

For additional information on calculations, refer to [BQ24040 Application Report](#).

##### 9.2.1.2.1.1 Program the Fast Charge Current, ISET:

$$R_{ISET} = [K_{(ISET)} / I_{(OUT)}] \quad (3)$$

From [Section 7.5](#):

- $K_{(SET)} = 540A\Omega$
- $R_{ISET} = [540A\Omega/0.54A] = 1.0\text{ k}\Omega$

Selecting the closest standard value, use a 1.0 k $\Omega$  resistor between ISET (terminal 16) and VSS.

##### 9.2.1.2.1.2 Program the Termination Current Threshold, ITERM:

$$R_{PRE-TERM} = K_{(TERM)} \times \%_{IOUT-FC} \quad (4)$$

$$R_{PRE-TERM} = 200\Omega/\% \times 10\% = 2\text{ k}\Omega \quad (5)$$

Selecting the closest standard value, use a 2 k $\Omega$  resistor between ITERM (terminal 15) and VSS.

One can arrive at the same value by using 20% for a pre-charge value (factor of 2 difference).

$$R_{PRE-TERM} = K_{(PRE-CHG)} \times \%_{IOUT-FC} \quad (6)$$

$$R_{PRE-TERM} = 100\Omega/\% \times 20\% = 2\text{ k}\Omega \quad (7)$$

##### 9.2.1.2.1.3 TS Function (BQ24040)

Use a 10k NTC thermistor in the battery pack (103AT).

To Disable the temp sense function, use a fixed 10k resistor between the TS (terminal 1) and VSS.

##### 9.2.1.2.1.4 $\overline{CHG}$ and PG

**LED Status:** connect a 1.5k resistor in series with a LED between the OUT terminal and the  $\overline{CHG}$  terminal. Connect a 1.5k resistor in series with a LED between the OUT terminal and the and PG terminal.

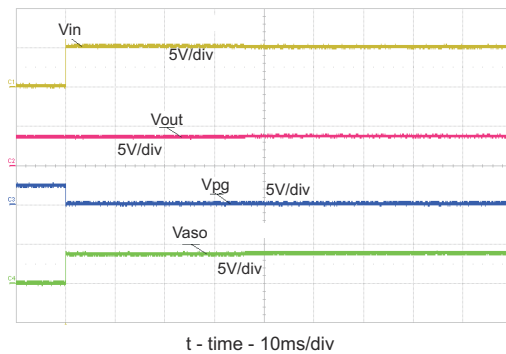
**Processor Monitoring:** Connect a pull-up resistor between the processor's power rail and the  $\overline{CHG}$  terminal. Connect a pull-up resistor between the processor's power rail and the PG terminal.

##### 9.2.1.2.2 Selecting In and Out Terminal Capacitors

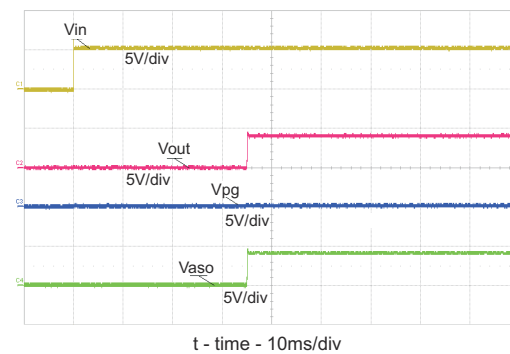
In most applications, all that is needed is a high-frequency decoupling capacitor (ceramic) on the power terminal, input and output terminals. Using the values shown on the application diagram, is recommended. After evaluation of these voltage signals with real system operational conditions, one can determine if capacitance values can be adjusted toward the minimum recommended values (DC load application) or higher values for fast high amplitude pulsed load applications. Note if designed for high input voltage sources (bad adaptors or wrong adaptors), the capacitor needs to be rated appropriately. Ceramic capacitors are tested to 2x their rated values so a 16V capacitor may be adequate for a 30V transient (verify tested rating with capacitor manufacturer).

### 9.2.1.3 Application Curves

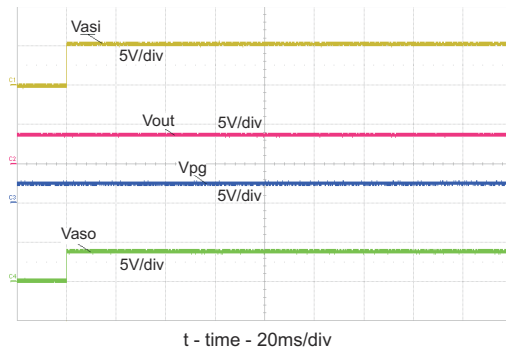
SETUP: BQ24040 typical applications schematic;  $V_{IN} = 5V$ ,  $V_{BAT} = 3.6V$  (unless otherwise indicated)



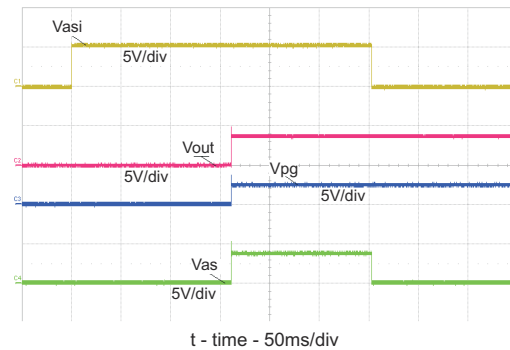
**Figure 9-2. Power-up Timing**



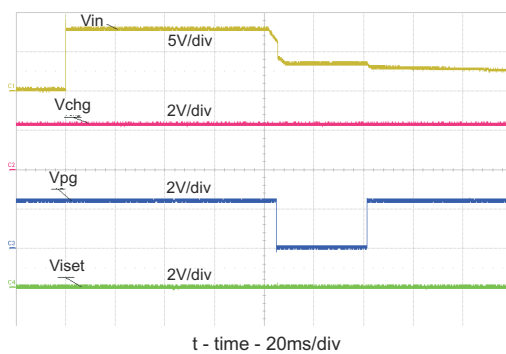
**Figure 9-3. Power-up Timing – No Battery or Load**



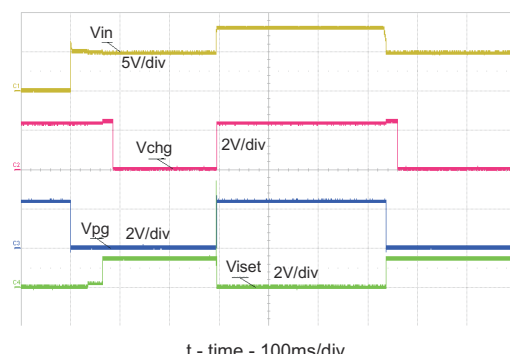
**Figure 9-4. – ASI and OUT Power-up Timing – No Input**



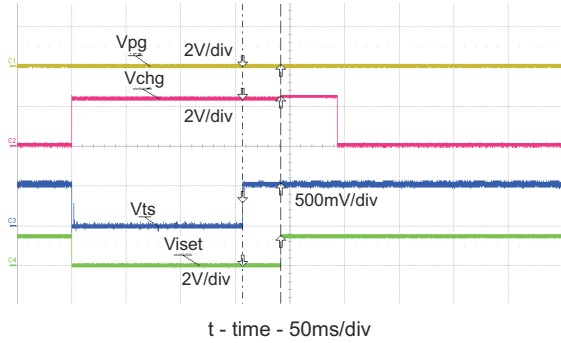
**Figure 9-5. ASI and delayed OUT Power-up Timing – No Input**



**Figure 9-6. OVP 8V Adaptor - Hot Plug**

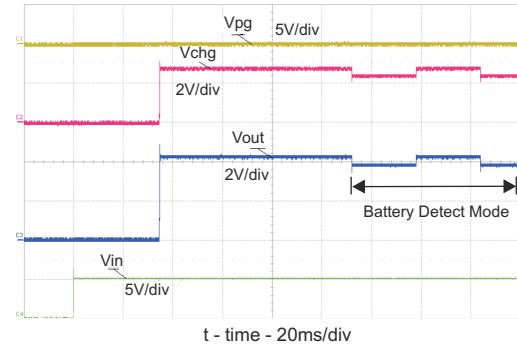


**Figure 9-7. OVP from Normal Power-up Operation –  $V_{IN} 0V \rightarrow 5V \rightarrow 8V \rightarrow 5V$**

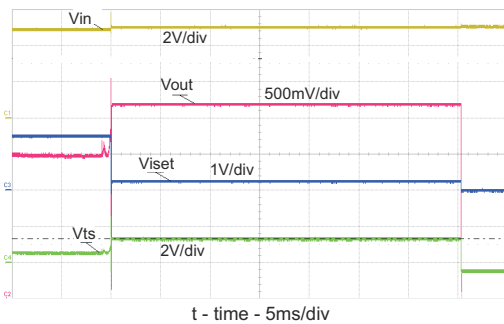


t - time - 50ms/div  
10kΩ resistor from TS to GND. 10kΩ is shorted to disable the IC

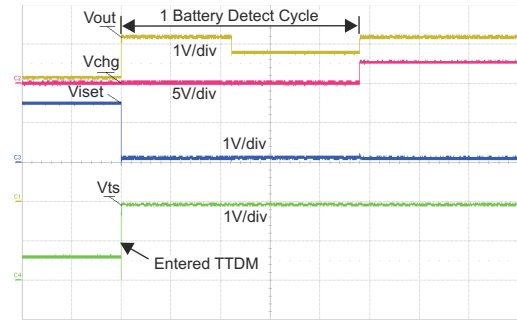
**Figure 9-8. TS Enable and Disable**



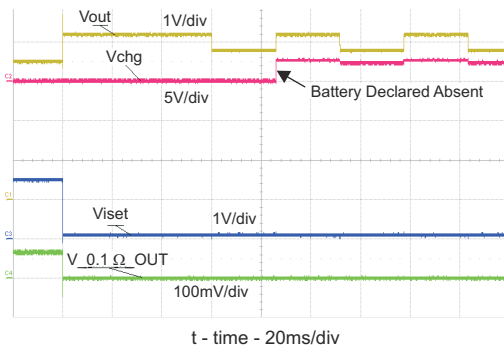
t - time - 20ms/div  
**Figure 9-9. Hot Plug Source w/No Battery – Battery Detection**



t - time - 5ms/div  
**Figure 9-10. Battery Removal – GND Removed 1st, 42 Ω Load**

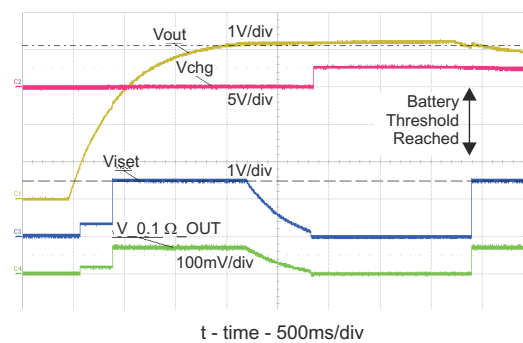


t - time - 10ms/div  
**Figure 9-11. Battery Removal with OUT and TS Disconnect 1st, With 100 Ω Load**



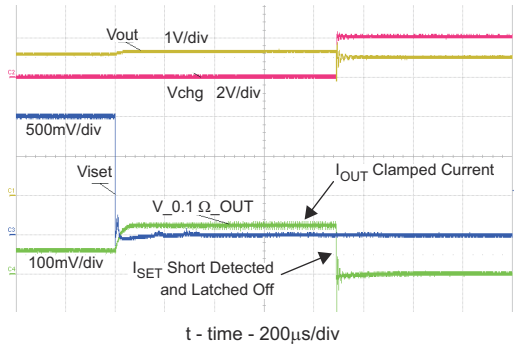
t - time - 20ms/div  
Continuous battery detection when not in TTDM

**Figure 9-12. Battery Removal with fixed TS = 0.5V**



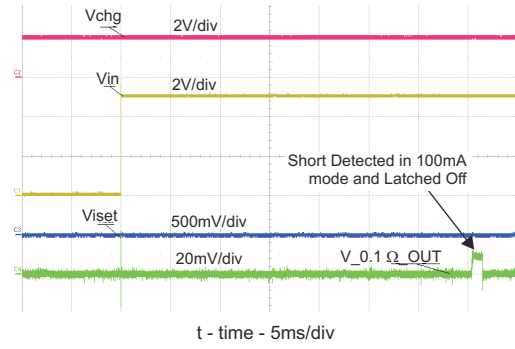
t - time - 500ms/div  
CH4: I<sub>OUT</sub> (1A/Div)  
Battery voltage swept from 0V to 4.25V to 3.9V.

**Figure 9-13. Battery Charge Profile**



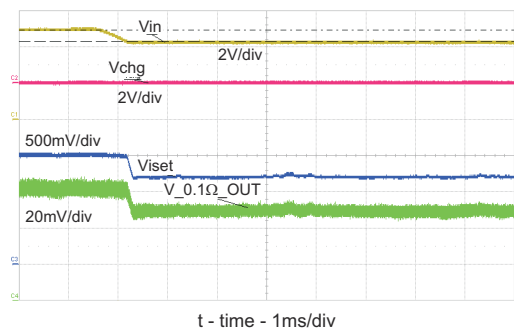
CH4: I<sub>OUT</sub> (1A/Div)

**Figure 9-14. ISET Shorted During Normal Operation**



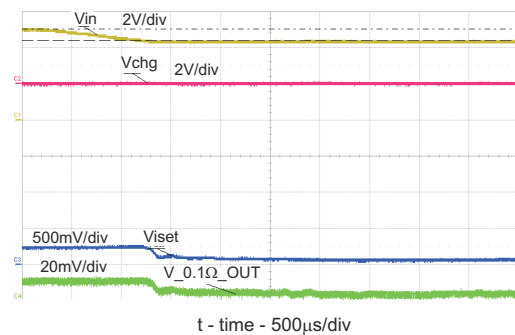
CH4: I<sub>OUT</sub> (0.2A/Div)

**Figure 9-15. ISET Shorted Prior to USB Power-up**

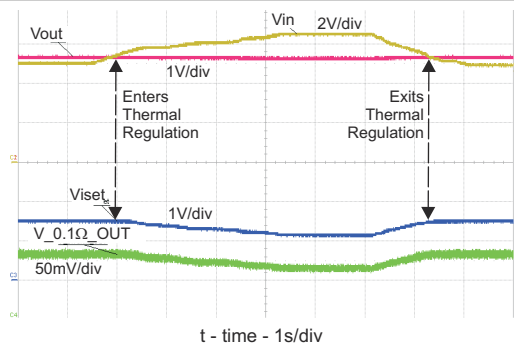


CH4: I<sub>OUT</sub> (0.2A/Div)

**Figure 9-16. DPM – Adaptor Current Limits – Vin Regulated**

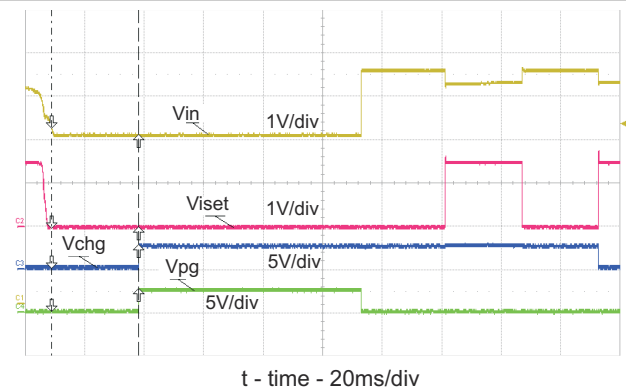


**Figure 9-17. DPM – USB Current Limits – Vin Regulated to 4.4V**



The IC temperature rises to 125°C and enters thermal regulation. Charge current is reduced to regulate the IC at 125°C. VIN is reduced, the IC temperature drops, the charge current returns to the programmed value

**Figure 9-18. Thermal Reg. – Vin increases PWR/ Iout Reduced**



V<sub>IN</sub> swept from 5V to 3.9V to 5V

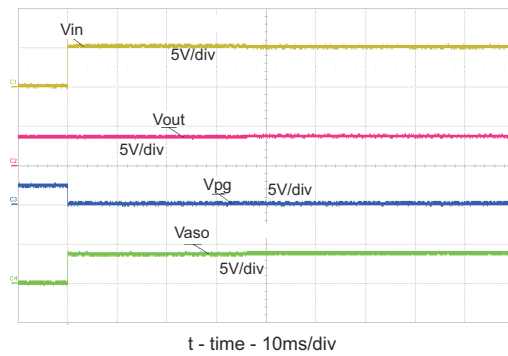
V<sub>BAT</sub> = 4V

**Figure 9-19. Entering and Exiting Sleep mode**

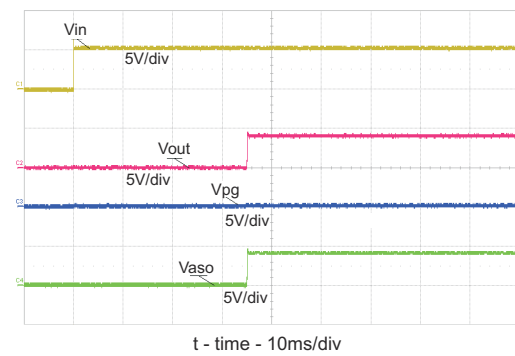


### 9.2.2.3 Application Curves

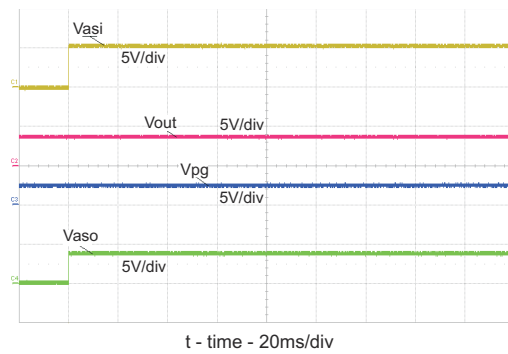
SETUP: BQ24041 typical applications schematic;  $V_{IN} = 5V$ ,  $V_{BAT} = 3.6V$  (unless otherwise indicated)



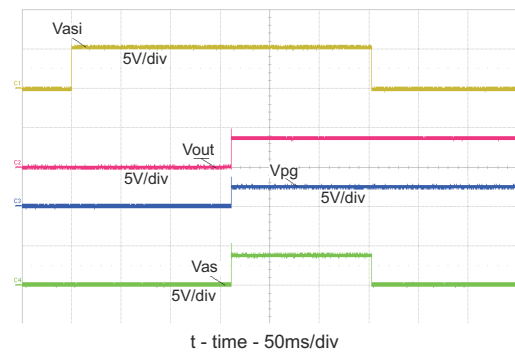
**Figure 9-21. Power-up Timing, BQ24041**



**Figure 9-22. Power-up Timing – No Battery or Load, BQ24041**



**Figure 9-23. – ASI and OUT Power-up Timing – No Input, BQ24041**



**Figure 9-24. ASI and Delayed OUT Power-up Timing – No Input, BQ24041**

## 10 Power Supply Recommendations

The devices are designed to operate from an input voltage supply range between 3.5 V and 28 V and current capability of at least the maximum designed charge current. This input supply should be well regulated. If located more than a few inches from the BQ24040x IN and GND terminals, a larger capacitor is recommended.

## 11 Layout

### 11.1 Layout Guidelines

To obtain optimal performance, the decoupling capacitor from IN to GND (thermal pad) and the output filter capacitors from OUT to GND (thermal pad) should be placed as close as possible to the BQ2405x, with short trace runs to both IN, OUT, and GND (thermal pad).

- All low-current GND connections should be kept separate from the high-current charge or discharge paths from the battery. Use a single-point ground technique incorporating both the small signal ground path and the power ground path.
- The high current charge paths into IN terminal and from the OUT terminal must be sized appropriately for the maximum charge current in order to avoid voltage drops in these traces
- The BQ2404x family is packaged in a thermally enhanced MLP package. The package includes a thermal pad to provide an effective thermal contact between the IC and the printed circuit board (PCB); this thermal pad is also the main ground connection for the device. Connect the thermal pad to the PCB ground connection. It is best to use multiple 10mil vias in the power pad of the IC and close enough to conduct the heat to the bottom ground plane. The bottom ground plane should avoid traces that “cut off” the thermal path. The thinner the PCB the less temperature rise. The EVM PCB has a thickness of 0.031 inches and uses 2 oz. (2.8mil thick) copper on top and bottom, and is a good example of optimal thermal performance.

### 11.2 Layout Example

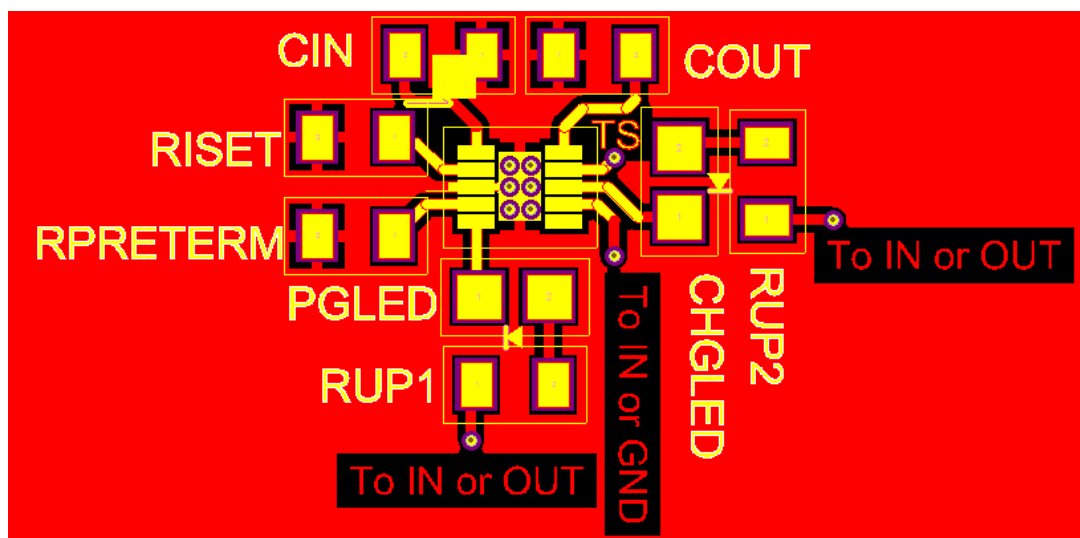


Figure 11-1. Board Layout

## 11.3 Thermal Considerations

The BQ2404x family is packaged in a thermally enhanced MLP package. The package includes a thermal pad to provide an effective thermal contact between the IC and the printed circuit board (PCB). The power pad should be directly connected to the VSS terminal. Full PCB design guidelines for this package are provided in the application note entitled: [QFN/SON PCB Attachment Application Report](#). The most common measure of package thermal performance is thermal impedance ( $R_{\theta JA}$ ) measured (or modeled) from the chip junction to the air surrounding the package surface (ambient). The mathematical expression for  $R_{\theta JA}$  is:

$$R_{\theta JA} = (T_J - T) / P \quad (8)$$

where

- $T_J$  = Chip junction temperature
- $T$  = Ambient temperature
- $P$  = Device power dissipation

Factors that can influence the measurement and calculation of  $R_{\theta JA}$  include:

1. Whether or not the device is board mounted
2. Trace size, composition, thickness, and geometry
3. Orientation of the device (horizontal or vertical)
4. Volume of the ambient air surrounding the device under test and airflow
5. Whether other surfaces are in close proximity to the device being tested

Due to the charge profile of Li-Ion and Li-Pol batteries the maximum power dissipation is typically seen at the beginning of the charge cycle when the battery voltage is at its lowest. Typically after fast charge begins the pack voltage increases to  $\approx 3.4V$  within the first 2 minutes. The thermal time constant of the assembly typically takes a few minutes to heat up so when doing maximum power dissipation calculations, 3.4V is a good minimum voltage to use. This is verified, with the system and a fully discharged battery, by plotting temperature on the bottom of the PCB under the IC (pad should have multiple vias), the charge current and the battery voltage as a function of time. The fast charge current will start to taper off if the part goes into thermal regulation.

The device power dissipation,  $P$ , is a function of the charge rate and the voltage drop across the internal PowerFET. It can be calculated from the following equation when a battery pack is being charged:

$$P = [V_{(IN)} - V_{(OUT)}] \times I_{(OUT)} + [V_{(OUT)} - V_{(BAT)}] \times I_{(BAT)} \quad (9)$$

The thermal loop feature reduces the charge current to limit excessive IC junction temperature. It is recommended that the design not run in thermal regulation for typical operating conditions (nominal input voltage and nominal ambient temperatures) and use the feature for non typical situations such as hot environments or higher than normal input source voltage. With that said, the IC will still perform as described, if the thermal loop is always active.

### 11.3.1 Leakage Current Effects on Battery Capacity

To determine how fast a leakage current on the battery will discharge the battery is an easy calculation. The time from full to discharge can be calculated by dividing the Amp-Hour Capacity of the battery by the leakage current. For a 0.75Ahr battery and a 10 $\mu$ A leakage current (750 mAhr / 0.010 mA = 75000 hours), it would take 75k hours or 8.8 years to discharge. In reality the self discharge of the cell would be much faster so the 10 $\mu$ A leakage would be considered negligible.

## 12 Device and Documentation Support

### 12.1 Device Support

#### 12.1.1 Third-Party Products Disclaimer

TI'S PUBLICATION OF INFORMATION REGARDING THIRD-PARTY PRODUCTS OR SERVICES DOES NOT CONSTITUTE AN ENDORSEMENT REGARDING THE SUITABILITY OF SUCH PRODUCTS OR SERVICES OR A WARRANTY, REPRESENTATION OR ENDORSEMENT OF SUCH PRODUCTS OR SERVICES, EITHER ALONE OR IN COMBINATION WITH ANY TI PRODUCT OR SERVICE.

### 12.2 Documentation Support

#### 12.2.1 Related Documentation

For related documentation see the following:

- [BQ24040 Pin FMA Application Report](#)
- [BQ2404x FIT Rate Application Report](#)
- [BQ24040 Application Report](#)
- [QFN/SON PCB Attachment Application Report](#)

### 12.3 Receiving Notification of Documentation Updates

To receive notification of documentation updates, navigate to the device product folder on [ti.com](#). Click on *Subscribe to updates* to register and receive a weekly digest of any product information that has changed. For change details, review the revision history included in any revised document.

### 12.4 Support Resources

[TI E2E™ support forums](#) are an engineer's go-to source for fast, verified answers and design help — straight from the experts. Search existing answers or ask your own question to get the quick design help you need.

Linked content is provided "AS IS" by the respective contributors. They do not constitute TI specifications and do not necessarily reflect TI's views; see TI's [Terms of Use](#).

### 12.5 Trademarks

TI E2E™ is a trademark of Texas Instruments.

All trademarks are the property of their respective owners.

### 12.6 Electrostatic Discharge Caution



This integrated circuit can be damaged by ESD. Texas Instruments recommends that all integrated circuits be handled with appropriate precautions. Failure to observe proper handling and installation procedures can cause damage.

ESD damage can range from subtle performance degradation to complete device failure. Precision integrated circuits may be more susceptible to damage because very small parametric changes could cause the device not to meet its published specifications.

### 12.7 Glossary

[TI Glossary](#) This glossary lists and explains terms, acronyms, and definitions.

## 13 Mechanical, Packaging, and Orderable Information

The following pages include mechanical packaging and orderable information. This information is the most current data available for the designated devices. This data is subject to change without notice and revision of this document. For browser-based versions of this data sheet, refer to the left-hand navigation.

**PACKAGING INFORMATION**

Orderable Device	Status (1)	Package Type	Package Drawing	Pins	Package Qty	Eco Plan (2)	Lead finish/ Ball material (6)	MSL Peak Temp (3)	Op Temp (°C)	Device Marking (4/5)	Samples
BQ24040DSQR	ACTIVE	WSON	DSQ	10	3000	RoHS & Green	NIPDAU   NIPDAUAG	Level-2-260C-1 YEAR	0 to 125	NXE	<a href="#">Samples</a>
BQ24040DSQT	ACTIVE	WSON	DSQ	10	250	RoHS & Green	NIPDAU   NIPDAUAG	Level-2-260C-1 YEAR	0 to 125	NXE	<a href="#">Samples</a>
BQ24041DSQR	ACTIVE	WSON	DSQ	10	3000	RoHS & Green	NIPDAUAG	Level-2-260C-1 YEAR	0 to 125	NXF	<a href="#">Samples</a>
BQ24041DSQT	ACTIVE	WSON	DSQ	10	250	RoHS & Green	NIPDAUAG	Level-2-260C-1 YEAR	0 to 125	NXF	<a href="#">Samples</a>
BQ24045DSQR	ACTIVE	WSON	DSQ	10	3000	RoHS & Green	NIPDAU   NIPDAUAG	Level-2-260C-1 YEAR	0 to 125	SII	<a href="#">Samples</a>
BQ24045DSQT	ACTIVE	WSON	DSQ	10	250	RoHS & Green	NIPDAU   NIPDAUAG	Level-2-260C-1 YEAR	0 to 125	SII	<a href="#">Samples</a>

(1) The marketing status values are defined as follows:

**ACTIVE:** Product device recommended for new designs.

**LIFEBUY:** TI has announced that the device will be discontinued, and a lifetime-buy period is in effect.

**NRND:** Not recommended for new designs. Device is in production to support existing customers, but TI does not recommend using this part in a new design.

**PREVIEW:** Device has been announced but is not in production. Samples may or may not be available.

**OBSOLETE:** TI has discontinued the production of the device.

(2) **RoHS:** TI defines "RoHS" to mean semiconductor products that are compliant with the current EU RoHS requirements for all 10 RoHS substances, including the requirement that RoHS substance do not exceed 0.1% by weight in homogeneous materials. Where designed to be soldered at high temperatures, "RoHS" products are suitable for use in specified lead-free processes. TI may reference these types of products as "Pb-Free".

**RoHS Exempt:** TI defines "RoHS Exempt" to mean products that contain lead but are compliant with EU RoHS pursuant to a specific EU RoHS exemption.

**Green:** TI defines "Green" to mean the content of Chlorine (Cl) and Bromine (Br) based flame retardants meet JS709B low halogen requirements of <=1000ppm threshold. Antimony trioxide based flame retardants must also meet the <=1000ppm threshold requirement.

(3) MSL, Peak Temp. - The Moisture Sensitivity Level rating according to the JEDEC industry standard classifications, and peak solder temperature.

(4) There may be additional marking, which relates to the logo, the lot trace code information, or the environmental category on the device.

(5) Multiple Device Markings will be inside parentheses. Only one Device Marking contained in parentheses and separated by a "-" will appear on a device. If a line is indented then it is a continuation of the previous line and the two combined represent the entire Device Marking for that device.

(6) Lead finish/Ball material - Orderable Devices may have multiple material finish options. Finish options are separated by a vertical ruled line. Lead finish/Ball material values may wrap to two lines if the finish value exceeds the maximum column width.

**Important Information and Disclaimer:** The information provided on this page represents TI's knowledge and belief as of the date that it is provided. TI bases its knowledge and belief on information provided by third parties, and makes no representation or warranty as to the accuracy of such information. Efforts are underway to better integrate information from third parties. TI has taken and continues to take reasonable steps to provide representative and accurate information but may not have conducted destructive testing or chemical analysis on incoming materials and chemicals. TI and TI suppliers consider certain information to be proprietary, and thus CAS numbers and other limited information may not be available for release.

In no event shall TI's liability arising out of such information exceed the total purchase price of the TI part(s) at issue in this document sold by TI to Customer on an annual basis.

**TAPE AND REEL INFORMATION**

**QUADRANT ASSIGNMENTS FOR PIN 1 ORIENTATION IN TAPE**


\*All dimensions are nominal

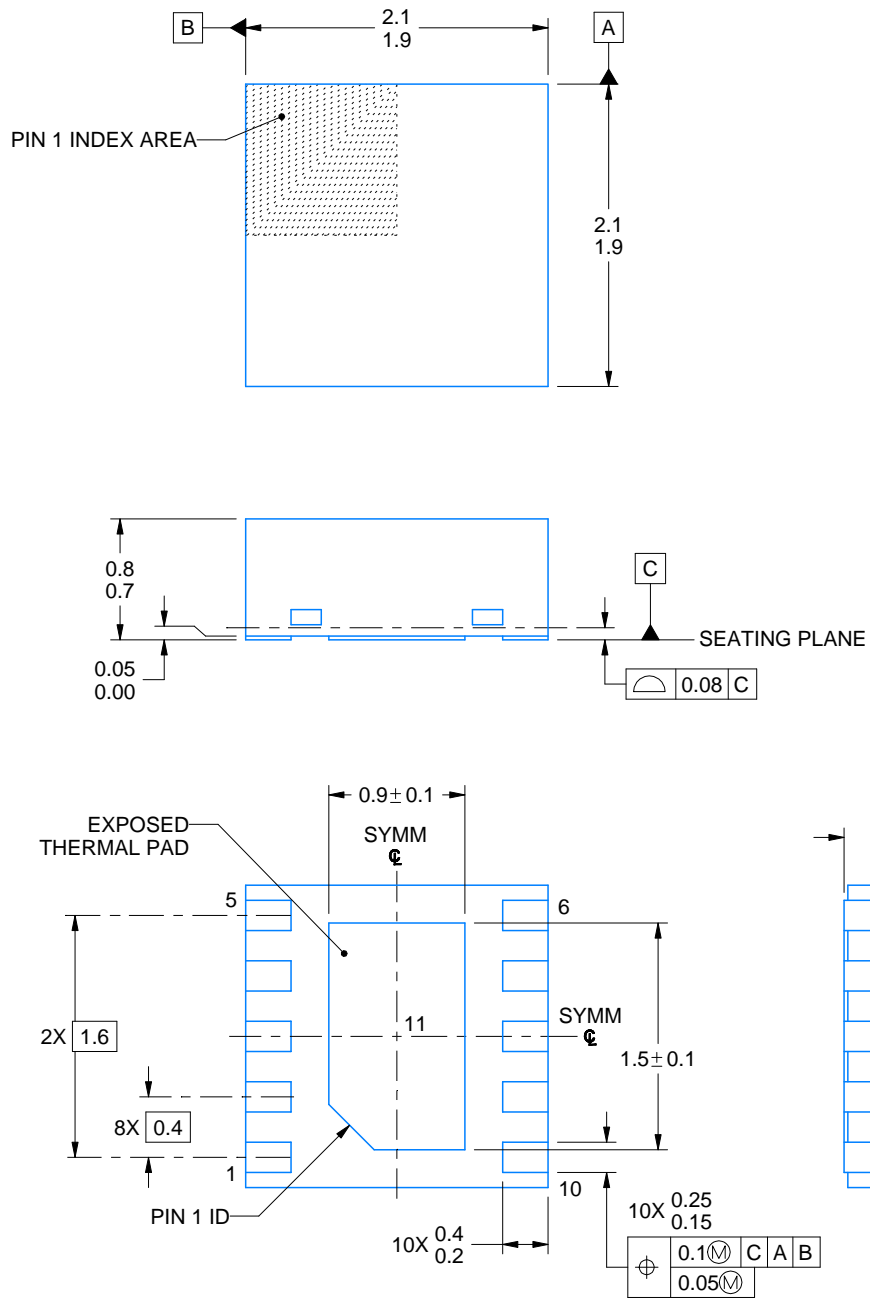
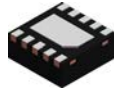
Device	Package Type	Package Drawing	Pins	SPQ	Reel Diameter (mm)	Reel Width W1 (mm)	A0 (mm)	B0 (mm)	K0 (mm)	P1 (mm)	W (mm)	Pin1 Quadrant
BQ24040DSQR	WSON	DSQ	10	3000	180.0	8.4	2.3	2.3	1.15	4.0	8.0	Q2
BQ24040DSQT	WSON	DSQ	10	250	180.0	8.4	2.3	2.3	1.15	4.0	8.0	Q2
BQ24041DSQR	WSON	DSQ	10	3000	179.0	8.4	2.2	2.2	1.2	4.0	8.0	Q2
BQ24041DSQT	WSON	DSQ	10	250	179.0	8.4	2.2	2.2	1.2	4.0	8.0	Q2
BQ24045DSQR	WSON	DSQ	10	3000	180.0	8.4	2.3	2.3	1.15	4.0	8.0	Q2
BQ24045DSQT	WSON	DSQ	10	250	180.0	8.4	2.3	2.3	1.15	4.0	8.0	Q2

## TAPE AND REEL BOX DIMENSIONS



\*All dimensions are nominal

Device	Package Type	Package Drawing	Pins	SPQ	Length (mm)	Width (mm)	Height (mm)
BQ24040DSQR	WSON	DSQ	10	3000	210.0	185.0	35.0
BQ24040DSQT	WSON	DSQ	10	250	210.0	185.0	35.0
BQ24041DSQR	WSON	DSQ	10	3000	213.0	191.0	35.0
BQ24041DSQT	WSON	DSQ	10	250	213.0	191.0	35.0
BQ24045DSQR	WSON	DSQ	10	3000	210.0	185.0	35.0
BQ24045DSQT	WSON	DSQ	10	250	210.0	185.0	35.0



4218906/A 04/2019

NOTES:

1. All linear dimensions are in millimeters. Any dimensions in parenthesis are for reference only. Dimensioning and tolerancing per ASME Y14.5M.
2. This drawing is subject to change without notice.
3. The package thermal pad must be soldered to the printed circuit board for thermal and mechanical performance.

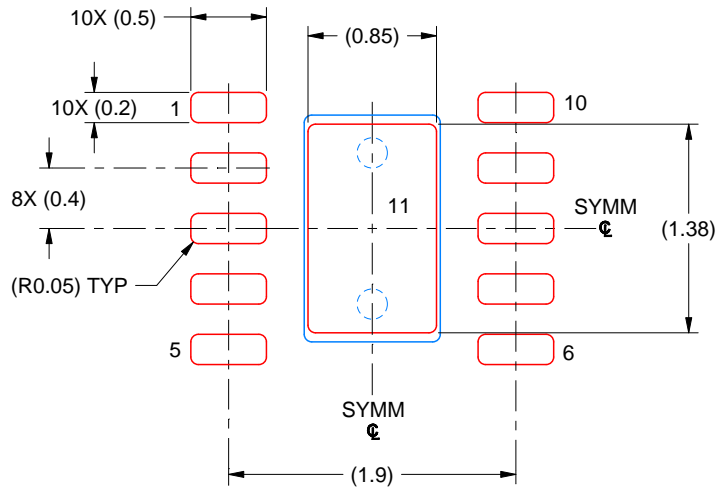


# EXAMPLE STENCIL DESIGN

DSQ0010A

WSON - 0.8 mm max height

PLASTIC SMALL OUTLINE - NO LEAD



SOLDER PASTE EXAMPLE  
BASED ON 0.125 MM THICK STENCIL  
SCALE: 20X

EXPOSED PAD 11  
87% PRINTED SOLDER COVERAGE BY AREA UNDER PACKAGE

4218906/A 04/2019

NOTES: (continued)

6. Laser cutting apertures with trapezoidal walls and rounded corners may offer better paste release. IPC-7525 may have alternate design recommendations.

## IMPORTANT NOTICE AND DISCLAIMER

TI PROVIDES TECHNICAL AND RELIABILITY DATA (INCLUDING DATA SHEETS), DESIGN RESOURCES (INCLUDING REFERENCE DESIGNS), APPLICATION OR OTHER DESIGN ADVICE, WEB TOOLS, SAFETY INFORMATION, AND OTHER RESOURCES "AS IS" AND WITH ALL FAULTS, AND DISCLAIMS ALL WARRANTIES, EXPRESS AND IMPLIED, INCLUDING WITHOUT LIMITATION ANY IMPLIED WARRANTIES OF MERCHANTABILITY, FITNESS FOR A PARTICULAR PURPOSE OR NON-INFRINGEMENT OF THIRD PARTY INTELLECTUAL PROPERTY RIGHTS.

These resources are intended for skilled developers designing with TI products. You are solely responsible for (1) selecting the appropriate TI products for your application, (2) designing, validating and testing your application, and (3) ensuring your application meets applicable standards, and any other safety, security, regulatory or other requirements.

These resources are subject to change without notice. TI grants you permission to use these resources only for development of an application that uses the TI products described in the resource. Other reproduction and display of these resources is prohibited. No license is granted to any other TI intellectual property right or to any third party intellectual property right. TI disclaims responsibility for, and you will fully indemnify TI and its representatives against, any claims, damages, costs, losses, and liabilities arising out of your use of these resources.

TI's products are provided subject to [TI's Terms of Sale](#) or other applicable terms available either on [ti.com](http://ti.com) or provided in conjunction with such TI products. TI's provision of these resources does not expand or otherwise alter TI's applicable warranties or warranty disclaimers for TI products.

TI objects to and rejects any additional or different terms you may have proposed.

Mailing Address: Texas Instruments, Post Office Box 655303, Dallas, Texas 75265  
Copyright © 2022, Texas Instruments Incorporated

## Looking for pricing, stock, or lifecycle information?

Click below to explore more details on WIN SOURCE:

 [View BQ24040DSQT](#) on WIN SOURCE

 [Texas Instruments](#) Information

## Optimize Your Supply Chain with WIN SOURCE Solutions

-  Global Sourcing Solution
-  Obsolete Management
-  Cost Control Management
-  Shortage Management
-  Alternative Solution
-  Excess Inventory Management