

SBS 1.1-COMPLIANT GAS GAUGE ENABLED WITH IMPEDANCE TRACK™ TECHNOLOGY FOR USE WITH THE bq29330

FEATURES

- Patented Impedance Track™ Technology Accurately Measures Available Charge in Li-Ion and Li-Polymer Batteries
- Better than 1% Error Over Lifetime of the Battery
- Instant Accuracy – No Learning Cycle Required
- Automatically adjusts for battery aging, battery self discharge and temperature inefficiencies
- Supports the Smart Battery Specification SBS V1.1
- Works With the TI bq29330 Analog Front-End (AFE) Protection IC to Provide Complete Pack Electronics Solution
- Full Array of Programmable Voltage, Current, and Temperature Protection Features
- Integrated Time Base Removes Need for External Crystal with Optional Crystal Input
- Electronics for 7.2-V, 10.8-V or 14.4-V Battery Packs With 50% Fewer External Components
- Based on a Powerful Low-Power RISC CPU Core With High-Performance Peripherals
- Integrated Field Programmable FLASH Memory Eliminates the Need for External Configuration Memory
- Measures Charge Flow Using a High-Resolution, 16-Bit Integrating Delta-Sigma Converter
 - Better Than 0.65 nVh of Resolution
 - Self-Calibrating
- Uses 16-Bit Delta-Sigma Converter for Accurate Voltage and Temperature Measurements
- Extensive Data Reporting Options For Improved System Interaction
- Optional Pulse Charging Feature for Improved Charge Times
- Drives 3-, 4- or 5-Segment LED Display for Remaining Capacity Indication
- Supports SHA-1 Authentication



Please be aware that an important notice concerning availability, standard warranty, and use in critical applications of Texas Instruments semiconductor products and disclaimers thereto appears at the end of this data sheet.

IMPEDANCE TRACK is a trademark of Texas Instruments.

- Lifetime Data Logging
- 30-Pin TSSOP (DBT)

APPLICATIONS

- Notebook PCs
- Medical and Test Equipment
- Portable Instrumentation

DESCRIPTION

The bq20z90 SBS-compliant gas gauge IC, incorporating patented Impedance Track™ technology, is designed for battery-pack or in-system installation. The bq20z90 measures and maintains an accurate record of available charge in Li-ion or Li-polymer batteries using its integrated high-performance analog peripherals. The bq20z90 monitors capacity change, battery impedance, open-circuit voltage, and other critical parameters of the battery pack, and reports the information to the system host controller over a serial-communication bus. It is designed to work with the bq29330 analog front-end (AFE) protection IC to maximize functionality and safety, and minimize component count and cost in smart battery circuits.

The Impedance Track technology continuously analyzes the battery impedance, resulting in superior gas-gauging accuracy. This enables remaining capacity to be calculated with discharge rate, temperature, and cell aging all accounted for during each stage of every cycle.

AVAILABLE OPTIONS

T _A	PACKAGE	
	30-PIN TSSOP (DBT) Tube	30-PIN TSSOP (DBT) Tape & Reel
–40°C to 85°C	bq20z90DBT ⁽¹⁾	bq20z90DBTR ⁽²⁾

(1) A single tube quantity is 50 units.

(2) A single reel quantity is 2000 units

SYSTEM PARTITIONING DIAGRAM

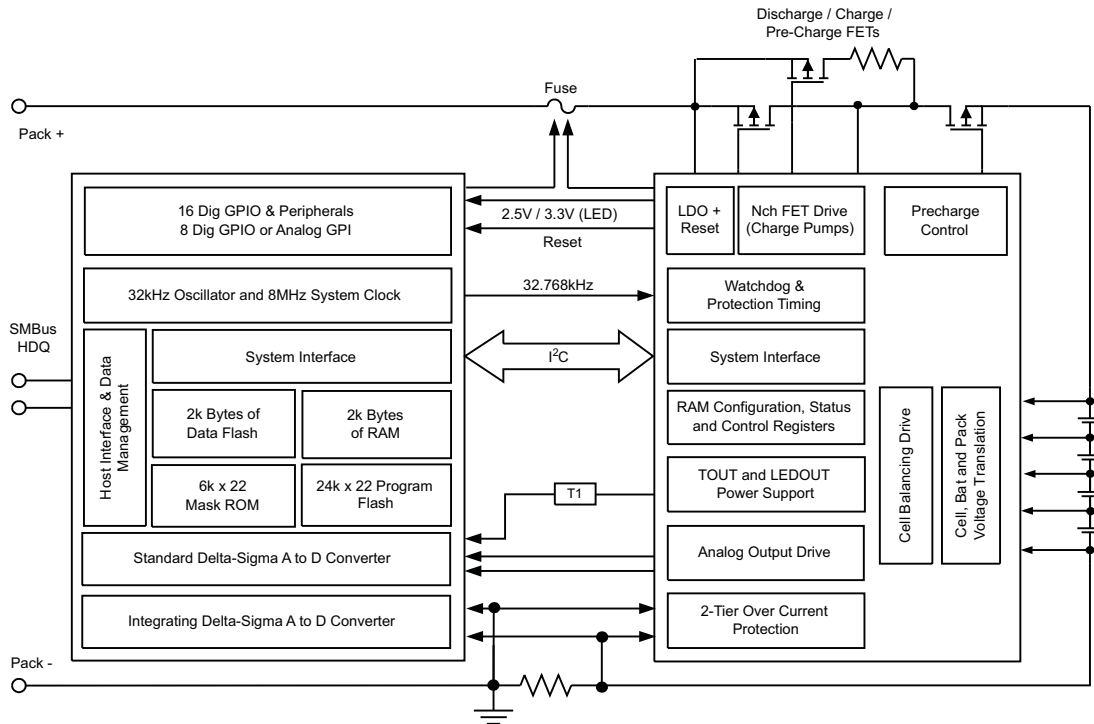

**TSSOP (DBT)
(TOP VIEW)**

NC	1	30	VCELL-
XALERT	2	29	VCELL+
SDATA	3	28	NC
SCLK	4	27	RBI
CLKOUT	5	26	VCC
TS1	6	25	VSS
TS2	7	24	MRST
PRES	8	23	SRN
PFIN	9	22	SRP
SAFE	10	21	*VSS
SMBD	11	20	LED5
NC	12	19	LED4
SMBC	13	18	LED3
DISP	14	17	LED2
NC	15	16	LED1

NC - No internal connection

TERMINAL FUNCTIONS

TERMINAL		I/O ⁽¹⁾	DESCRIPTION
NO.	NAME		
1	NC	–	Not used— leave floating
2	XALERT	I	Input from bq29330 XALERT output.
3	SDATA	I/O	Data transfer to and from bq29330
4	SCLK	I/O	Communication clock to the bq29330
5	CLKOUT	O	32.768-kHz output for the bq29330. This pin should be directly connected to the AFE.
6	TS1	I	1 st Thermistor voltage input connection to monitor temperature
7	TS2	I	2 nd Thermistor voltage input connection to monitor temperature
8	PRES	I	Active low input to sense system insertion and typically requires additional ESD protection
9	PFIN	I	Active low input to detect secondary protector output status and allows the bq20z90 to report the status of the 2 nd level protection output
10	SAFE	O	Active high output to enforce additional level of safety protection; e.g., fuse blow.
11	SMBD	I/OD	SMBus data open-drain bidirectional pin used to transfer address and data to and from the bq20z90
12	NC	–	Not used— leave floating
13	SMBC	I/OD	SMBus clock open-drain bidirectional pin used to clock the data transfer to and from the bq20z90
14	DISP	I	Display control for the LEDs. This pin is typically connected to bq29330 REG via a 100-kΩ resistor and a push-button switch to VSS.
15	NC	–	Not used— leave floating
16	LED1	O	LED1 display segment that drives an external LED depending on the firmware configuration
17	LED2	O	LED2 display segment that drives an external LED depending on the firmware configuration
18	LED3	O	LED3 display segment that drives an external LED depending on the firmware configuration
19	LED4	O	LED4 display segment that drives an external LED depending on the firmware configuration
20	LED5	O	LED5 display segment that drives an external LED depending on the firmware configuration
21	VSS	–	Connected I/O pin to VSS
22	SRP	IA	Connections to the top of a small-value sense resistor to monitor the battery charge- and discharge-current flow
23	SRN	IA	Connections to the bottom of a small-value sense resistor to monitor the battery charge- and discharge-current flow
24	MRST	I	Master reset input that forces the device into reset when held low. Must be held high for normal operation
25	VSS	P	Negative Supply Voltage
26	VCC	P	Positive Supply Voltage
27	RBI	P	Backup power to the bq20z90 data registers during periods of low operating voltage. RBI accepts a storage capacitor or a battery input.
28	NC	–	Not used— leave floating
29	VCELL+	I	Input from bq29330 used to read a scaled value of individual cell voltages
30	VCELL-	I	Input from bq29330 used to read a scaled value of individual cell voltages

(1) I = Input, IA = Analog input, I/O = Input/output, I/OD = Input/Open-drain output, O = Output, OA = Analog output, P = Power

ABSOLUTE MAXIMUM RATINGS

over operating free-air temperature range (unless otherwise noted)⁽¹⁾

		RANGE
V_{CC} relative to V_{SS}	Supply voltage range	–0.3 V to 2.75 V
$V_{(IOD)}$ relative to V_{SS}	Open-drain I/O pins	–0.3 V to 6 V
V_I relative to V_{SS}	Input voltage range to all other pins	–0.3 V to $V_{CC} + 0.3$ V
T_A	Operating free-air temperature range	–40°C to 85°C
T_{stg}	Storage temperature range	–65°C to 150°C

(1) Stresses beyond those listed under absolute maximum ratings may cause permanent damage to the device. These are stress ratings only, and functional operation of the device at these or any other conditions beyond those indicated under recommended operating conditions is not implied. Exposure to absolute-maximum-rated conditions for extended periods may affect device reliability.

ELECTRICAL CHARACTERISTICS

$V_{CC} = 2.4$ V to 2.6 V, $T_A = -40^\circ\text{C}$ to 85°C (unless otherwise noted)

PARAMETER		TEST CONDITIONS	MIN	TYP	MAX	UNIT
V_{CC}	Supply voltage		2.4	2.5	2.6	V
I_{CC}	Operating mode current	No flash programming		400 ⁽¹⁾		μA
		bq20z90 + bq29330		475		
$I_{(SLP)}$	Low-power storage mode current	Sleep mode		8 ⁽¹⁾		μA
		bq20z90 + bq29330		51		
V_{OL}	Output voltage low SMBC, SMBD, SDATA, SCLK, SAFE	$I_{OL} = 0.5$ mA			0.4	V
	LED1 – LED5	$I_{OL} = 10$ mA			0.4	V
V_{OH}	Output high voltage, SMBC, SMBD, SDATA, SCLK, SAFE	$I_{OH} = -1$ mA	$V_{CC} - 0.5$			V
V_{IL}	Input voltage low SMBC, SMBD, SDATA, SCLK, XALERT, $\overline{\text{PRES}}$, $\overline{\text{PFIN}}$		–0.3		0.8	V
	DISP		–0.3		0.8	V
V_{IH}	Input voltage high SMBC, SMBD, SDATA, SCLK, XALERT, $\overline{\text{PRES}}$, $\overline{\text{PFIN}}$		2		6	V
	DISP		2	$V_{CC} + 0.3$		V
C_{IN}	Input capacitance			5		pF
$V_{(AI1)}$	Input voltage range VCELL+, VCELL-, TS1, TS2		–0.2		$0.8XV_{CC}$	V
$V_{(AI2)}$	Input voltage range SRN, SRP		–0.20		0.20	V
$Z_{(AI2)}$	Input impedance VCELL+, VCELL-, TS1, TS2	0 V–1 V		8		$\text{M}\Omega$
$Z_{(AI1)}$	Input impedance SRN, SRP	0 V–1 V		2.5		$\text{M}\Omega$

(1) This value does not include the bq29330

POWER-ON RESET

$V_{CC} = 2.4V$ to $2.6V$, $T_A = -40^\circ C$ to $85^\circ C$ (unless otherwise noted)

PARAMETER	TEST CONDITIONS	MIN	TYP	MAX	UNIT
V_{IT-} Negative-going voltage input		1.7	1.8	1.9	V
V_{HYS} Power-on reset hysteresis		50	125	200	mV

POWER ON RESET BEHAVIOR
VS
FREE-AIR TEMPERATURE

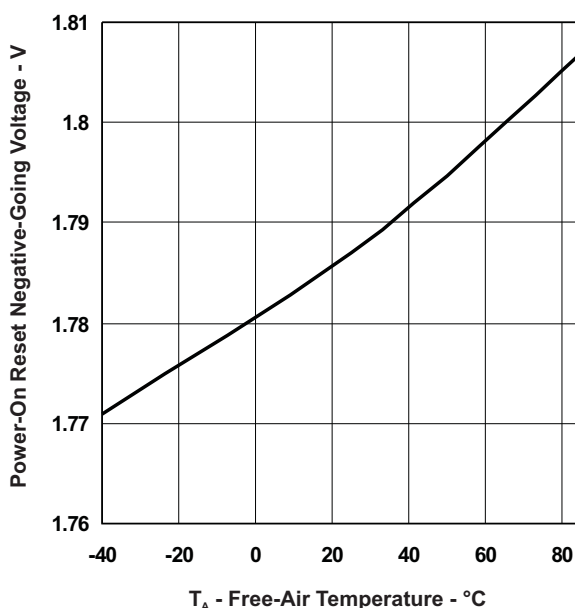

INTEGRATING ADC (Coulomb Counter) CHARACTERISTICS

$V_{CC} = 2.4V$ to $2.6V$, $T_A = -40^\circ C$ to $85^\circ C$ (unless otherwise noted)

PARAMETER	TEST CONDITIONS	MIN	TYP	MAX	UNIT
$V_{(SR)}$ Input voltage range, $V_{(SRN)}$ and $V_{(SRP)}$	$V_{(SR)} = V_{(SRN)} - V_{(SRP)}$	-0.2		0.2	V
$V_{(SROS)}$ Input offset			10		μV
INL Integral nonlinearity error			0.007%	0.034%	

OSCILLATOR

$V_{CC} = 2.4V$ to $2.6V$, $T_A = -40^\circ C$ to $85^\circ C$ (unless otherwise noted)

PARAMETER	TEST CONDITIONS	MIN	TYP	MAX	UNIT
HIGH FREQUENCY OSCILLATOR					
$f_{(OSC)}$ Operating Frequency				4.194	MHz
$f_{(EIO)}$ Frequency Error ⁽¹⁾⁽²⁾		-3%	0.25%	3%	
	$T_A = 20^\circ C$ to $70^\circ C$	-2%	0.25%	2%	
$t_{(SXO)}$ Start-up Time ⁽³⁾			2.5	5	ms
LOW FREQUENCY OSCILLATOR					
$f_{(LOSC)}$ Operating Frequency			32.768		KHz
$f_{(LEIO)}$ Frequency Error ⁽²⁾⁽⁴⁾		-2.5%	0.25%	2.5%	
	$T_A = 20^\circ C$ to $70^\circ C$	-1.5%	0.25%	1.5%	

(1) The frequency error is measured from 4.194 MHz.

(2) The frequency drift is included and measured from the trimmed frequency at $V_{CC} = 2.5V$, $T_A = 25^\circ C$.

(3) The start-up time is defined as the time it takes for the oscillator output frequency to be within 1% of the specified frequency.

(4) The frequency error is measured from 32.768 kHz.

OSCILLATOR (continued)

$V_{CC} = 2.4\text{ V to }2.6\text{ V}$, $T_A = -40^\circ\text{C to }85^\circ\text{C}$ (unless otherwise noted)

PARAMETER	TEST CONDITIONS	MIN	TYP	MAX	UNIT
$t_{(LSXO)}$ Start-up time ⁽⁵⁾				500	μs

(5) The start-up time is defined as the time it takes for the oscillator output frequency to be $\pm 3\%$.

DATA FLASH MEMORY CHARACTERISTICS

$V_{CC} = 2.4\text{ V to }2.6\text{ V}$, $T_A = -40^\circ\text{C to }85^\circ\text{C}$ (unless otherwise noted)

PARAMETER	TEST CONDITIONS	MIN	TYP	MAX	UNIT
t_{DR} Data retention	See ⁽¹⁾	10			Years
Flash programming write-cycles	See ⁽¹⁾	20,000			Cycles
$t_{(WORDPROG)}$ Word programming time	See ⁽¹⁾			2	ms
$I_{(DDdPROG)}$ Flash-write supply current	See ⁽¹⁾		5	10	mA

(1) Assured by design. Not production tested

REGISTER BACKUP

$V_{CC} = 2.4\text{ V to }2.6\text{ V}$, $T_A = -40^\circ\text{C to }85^\circ\text{C}$ (unless otherwise noted)

PARAMETER	TEST CONDITIONS	MIN	TYP	MAX	UNIT
$I_{(RB)}$ RB data-retention input current	$V_{(RB)} > V_{(RBMIN)}$, $V_{CC} < V_{IT-}$			1500	nA
	$V_{(RB)} > V_{(RBMIN)}$, $V_{CC} < V_{IT-}$, $T_A = 0^\circ\text{C to }50^\circ\text{C}$		40	160	
$V_{(RB)}$ RB data-retention voltage ⁽¹⁾		1.7			V

(1) Specified by design. Not production tested.

SMBus TIMING SPECIFICATIONS

$V_{CC} = 2.4\text{ V to }2.6\text{ V}$, $T_A = -40^\circ\text{C to }85^\circ\text{C}$ (unless otherwise noted)

PARAMETER	TEST CONDITIONS	MIN	TYP	MAX	UNIT
f_{SMB}	SMBus operating frequency	Slave mode, SMBC 50% duty cycle	10	100	kHz
f_{MAS}	SMBus master clock frequency	Master mode, no clock low slave extend	51.2		
t_{BUF}	Bus free time between start and stop		4.7		μs
$t_{HD:STA}$	Hold time after (repeated) start		4		
$t_{SU:STA}$	Repeated start setup time		4.7		
$t_{SU:STO}$	Stop setup time		4		
$t_{HD:DAT}$	Data hold time	Receive mode	0		ns
		Transmit mode	300		
$t_{SU:DAT}$	Data setup time		250		
$t_{TIMEOUT}$	Error signal/detect	See (1)	25	35	ms
t_{LOW}	Clock low period		4.7		μs
t_{HIGH}	Clock high period	See (2)	4	50	
$t_{LOW:SEXT}$	Cumulative clock low slave extend time	See (3)		25	ms
$t_{LOW:MEXT}$	Cumulative clock low master extend time	See (4)		10	
t_F	Clock/data fall time	$(V_{ILMAX} - 0.15\text{ V})$ to $(V_{IHMIN} + 0.15\text{ V})$		300	ns
t_R	Clock/data rise time	0.9 VCC to $(V_{ILMAX} - 0.15\text{ V})$		1000	

- (1) The bq20z90 times out when any clock low exceeds $t_{TIMEOUT}$.
- (2) $t_{HIGH:MAX}$ is minimum bus idle time. SMBC = 1 for $t > 50\ \mu\text{s}$ causes reset of any transaction involving the bq20z90 that is in progress.
- (3) $t_{LOW:SEXT}$ is the cumulative time a slave device is allowed to extend the clock cycles in one message from initial start to the stop.
- (4) $t_{LOW:MEXT}$ is the cumulative time a master device is allowed to extend the clock cycles in one message from initial start to the stop.

SMBus TIMING DIAGRAM

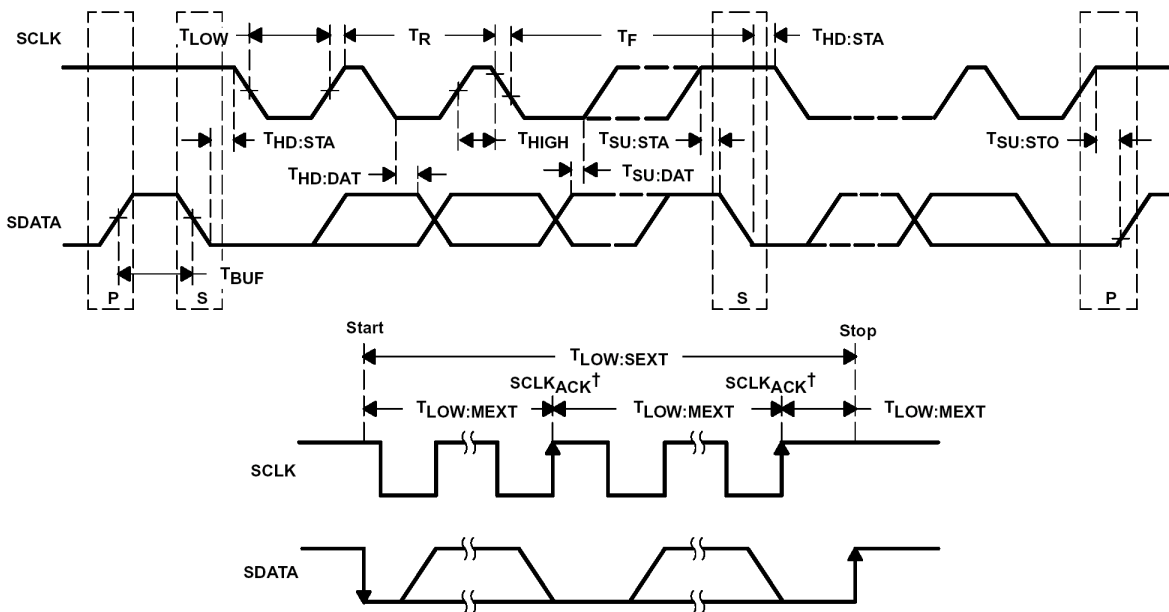

$SCLKACK^\dagger$ is the acknowledge-related clock pulse generated by the master.

FEATURE SET

Primary (1st Level) Safety Features

The bq20z90 supports a wide range of battery and system protection features that can easily be configured. The primary safety features include:

- Battery cell over/under voltage protection
- Battery pack over/under voltage protection
- 2 independent charge overcurrent protection
- 3 independent discharge overcurrent protection
- Short circuit protection
- Over temperature protection
- AFE Watchdog
- Host Watchdog

Secondary (2nd Level) Safety Features

The secondary safety features of the bq20z90 can be used to indicate more serious faults via the SAFE (pin 10) pin. This pin can be used to blow an in-line fuse to permanently disable the battery pack from charging or discharging. The secondary safety features include:

- Safety over voltage
- Battery cell imbalance
- 2nd level protection IC input
- Safety over current
- Safety over temperature
- Open thermistor
- Charge FET and Zero-Volt Charge FET fault
- Discharge FET fault
- Fuse blow failure detection
- AFE Communication error
- AFE Verification error
- Internal flash data error

Charge Control Features

The bq20z90 charge control features include:

- Report the appropriate charging current needed for constant current charging and the appropriate charging voltage needed for constant voltage charging to a smart charger using SMBus broadcasts.
- Determine the chemical state of charge of each battery cell using Impedance Track™. Using cell balancing algorithm, gradually decrease the differences in the cells' state of charge in a fully charged state. This prevents high cells from overcharging, causing excessive degradation and also increases the usable pack energy by preventing early charge termination.
- Support Pre-charging/Zero-volt charging
- Support Fast charging
- Support Pulse charging
- Support Charge Inhibit and Charge Suspend modes
- Report charging faults and also indicate charging status via charge and discharge alarms.

Gas Gauging

The bq20z90 uses the Impedance Track™ Technology to measure and calculate the available charge in battery cells. The achievable accuracy is better than 1% error over the lifetime of the battery and there is no full charge-discharge learning cycle required.

See *Theory and Implementation of Impedance Track Battery Fuel-Gauging Algorithm* application note (SLUA364) for further details.

LED Display

The bq20z90 can drive a 3-, 4-, or 5- segment LED display for remaining capacity indication. The LED drive current can be adjusted to 3mA, 4mA and 5mA digitally.

LifeTime Data Logging Features

The bq20z90 offers a lifetime data logging array, where all important measurements are stored for warranty and analysis purposes. The data monitored include:

- Lifetime maximum temperature
- Lifetime minimum temperature
- Lifetime maximum battery cell voltage
- Lifetime minimum battery cell voltage
- Lifetime maximum battery pack voltage
- Lifetime minimum battery pack voltage
- Lifetime maximum charge current
- Lifetime maximum discharge current
- Lifetime maximum charge power
- Lifetime maximum discharge power
- Lifetime maximum average discharge current
- Lifetime maximum average discharge power
- Lifetime average temperature

Authentication

The bq20z90 supports authentication by the host using SHA-1.

Power Modes

The bq20z90 supports 3 different power modes to reduce power consumption:

- In Normal Mode, the bq20z90 performs measurements, calculations, protection decisions, and data updates in 1 second intervals. Between these intervals, the bq20z90 is in a reduced power stage.
- In Sleep Mode, the bq20z90 performs measurements, calculations, protection decisions, and data updates in adjustable time intervals. Between these intervals, the bq20z90 is in a reduced power stage.
- In Shutdown Mode the bq20z90 is completely disabled.

CONFIGURATION

Oscillator Function

The bq20z90 fully integrates the system and processor oscillators and, therefore, requires no pins or components for this feature.

System Present Operation

The bq20z90 periodically verifies the $\overline{\text{PRES}}$ pin and detects that the battery is present in the system via a low state on a $\overline{\text{PRES}}$ input. When this occurs, bq20z90 enters normal operating mode. When the pack is removed from the system and the $\overline{\text{PRES}}$ input is high, the bq20z90 enters the battery-removed state, disabling the charge, discharge and ZVCHG FETs. The $\overline{\text{PRES}}$ input is ignored and can be left floating when non-removal mode is set in the data flash.

BATTERY PARAMETER MEASUREMENTS

The bq20z90 uses an integrating delta-sigma analog-to-digital converter (ADC) for current measurement, and a second delta-sigma ADC for individual cell and battery voltage, and temperature measurement.

Charge and Discharge Counting

The integrating delta-sigma ADC measures the charge/discharge flow of the battery by measuring the voltage drop across a small-value sense resistor between the SRP and SRN pins. The integrating ADC measures bipolar signals from -0.25 V to 0.25 V. The bq20z90 detects charge activity when $V_{SR} = V_{(SRP)} - V_{(SRN)}$ is positive and discharge activity when $V_{SR} = V_{(SRP)} - V_{(SRN)}$ is negative. The bq20z90 continuously integrates the signal over time, using an internal counter. The fundamental rate of the counter is 0.65 nVh.

Voltage

The bq20z90 updates the individual series cell voltages through the bq29330 at one second intervals. The bq20z90 configures the bq29330 to connect the selected cell, cell offset, or bq29330 VREF to the CELL pin of the bq29330, which is required to be connected to VIN of the bq20z90. The internal ADC of the bq20z90 measures the voltage, scales it, and calibrates itself appropriately. This data is also used to calculate the impedance of the cell for the Impedance Track™ gas-gauging.

Current

The bq20z90 uses the SRP and SRN inputs to measure and calculate the battery charge and discharge current using a 5 mΩ to 20 mΩ typ. sense resistor.

Wake Function

The bq20z90 can exit sleep mode, if enabled, by the presence of a programmable level of current signal across SRP and SRN.

Auto Calibration

The bq20z90 provides an auto-calibration feature to cancel the voltage offset error across SRP and SRN for maximum charge measurement accuracy. The bq20z90 performs auto-calibration when the SMBus lines stay low continuously for a minimum of a programmable amount of time.

Temperature

The bq20z90 TS1 and TS2 inputs, in conjunction with two identical NTC thermistors (default are Semitec 103AT), measure the battery environmental temperature. The bq20z90 can also be configured to use its internal temperature sensor.

COMMUNICATIONS

The bq20z90 uses SMBus v1.1 with Master Mode and package error checking (PEC) options per the SBS specification.

SMBus On and Off State

The bq20z90 detects an SMBus off state when SMBC and SMBD are logic-low for ≥ 2 seconds. Clearing this state requires either SMBC or SMBD to transition high. Within 1 ms, the communication bus is available.

SBS Commands

Table 1. SBS COMMANDS

SBS Cmd	Mode	Name	Format	Size in Bytes	Min Value	Max Value	Default Value	Unit
0x00	R/W	ManufacturerAccess	hex	2	0x0000	0xffff	—	
0x01	R/W	RemainingCapacityAlarm	unsigned int	2	0	65535	300	mAh or 10mWh
0x02	R/W	RemainingTimeAlarm	unsigned int	2	0	65535	10	min
0x03	R/W	BatteryMode	hex	2	0x0000	0xe383	—	
0x04	R/W	AtRate	signed int	2	-32768	32767	—	mA or 10mW
0x05	R	AtRateTimeToFull	unsigned int	2	0	65534	—	min
0x06	R	AtRateTimeToEmpty	unsigned int	2	0	65534	—	min

Table 1. SBS COMMANDS (continued)

SBS Cmd	Mode	Name	Format	Size in Bytes	Min Value	Max Value	Default Value	Unit
0x07	R	AtRateOK	unsigned int	2	0	65535	—	
0x08	R	Temperature	unsigned int	2	0	65535	—	0.1°K
0x09	R	Voltage	unsigned int	2	0	65535	—	mV
0x0a	R	Current	signed int	2	-32768	32767	—	mA
0x0b	R	AverageCurrent	signed int	2	-32768	32767	—	mA
0x0c	R	MaxError	unsigned int	1	0	100	—	%
0x0d	R	RelativeStateOfCharge	unsigned int	1	0	100	—	%
0x0e	R	AbsoluteStateOfCharge	unsigned int	1	0	100+	—	%
0x0f	R/W	RemainingCapacity	unsigned int	2	0	65535	—	mAh or 10mWh
0x10	R	FullChargeCapacity	unsigned int	2	0	65535	—	mAh or 10mWh
0x11	R	RunTimeToEmpty	unsigned int	2	0	65534	—	min
0x12	R	AverageTimeToEmpty	unsigned int	2	0	65534	—	min
0x13	R	AverageTimeToFull	unsigned int	2	0	65534	—	min
0x14	R	ChargingCurrent	unsigned int	2	0	65534	—	mA
0x15	R	ChargingVoltage	unsigned int	2	0	65534	—	mV
0x16	R	BatteryStatus	unsigned int	2	0x0000	0xdbff	—	
0x17	R/W	CycleCount	unsigned int	2	0	65535	—	
0x18	R/W	DesignCapacity	unsigned int	2	0	65535	4400	mAh or 10mWh
0x19	R/W	DesignVoltage	unsigned int	2	0	65535	14400	mV
0x1a	R/W	SpecificationInfo	hex	2	0x0000	0xffff	0x0031	
0x1b	R/W	ManufactureDate	unsigned int	2	—	—	01-Jan-1980	ASCII
0x1c	R/W	SerialNumber	hex	2	0x0000	0xffff	0x0001	
0x20	R/W	ManufacturerName	String	11+1	—	—	Texas Inst.	ASCII
0x21	R/W	DeviceName	String	7+1	—	—	bq20z90	ASCII
0x22	R/W	DeviceChemistry	String	4+1	—	—	LION	ASCII
0x23	R/W	ManufacturerData	String	14+1	—	—	—	ASCII
0x2f	R/W	Authenticate	String	20+1	—	—	—	ASCII
0x3c	R	CellVoltage4	unsigned int	2	0	65535	—	mV
0x3d	R	CellVoltage3	unsigned int	2	0	65535	—	mV
0x3e	R	CellVoltage2	unsigned int	2	0	65535	—	mV
0x3f	R	CellVoltage1	unsigned int	2	0	65535	—	mV

Table 2. EXTENDED SBS COMMANDS

SBS Cmd	Mode	Name	Format	Size in Bytes	Min Value	Max Value	Default Value	Unit
0x45	R	AFEDData	String	11+1	—	—	—	ASCII
0x46	R/W	FETControl	hex	1	0x00	0x1e	—	
0x4f	R	StateOfHealth	unsigned int	1	0	100	—	%
0x50	R	SafetyAlert	hex	2	0x0000	0xffff	—	
0x51	R	SafetyStatus	hex	2	0x0000	0xffff	—	
0x52	R	PFAlert	hex	2	0x0000	0x9fff	—	
0x53	R	PFStatus	hex	2	0x0000	0x9fff	—	
0x54	R	OperationStatus	hex	2	0x0000	0xf7f7	—	
0x55	R	ChargingStatus	hex	2	0x0000	0xffff	—	

Table 2. EXTENDED SBS COMMANDS (continued)

SBS Cmd	Mode	Name	Format	Size in Bytes	Min Value	Max Value	Default Value	Unit
0x57	R	ResetData	hex	2	0x0000	0xffff	—	
0x58	R	WDRResetData	unsigned int	2	0	65535	—	
0x5a	R	PackVoltage	unsigned int	2	0	65535	---	mV
0x5d	R	AverageVoltage	unsigned int	2	0	65535	—	mV
0x60	R/W	UnSealKey	hex	4	0x00000000	0xffffffff	—	
0x61	R/W	FullAccessKey	hex	4	0x00000000	0xffffffff	—	
0x62	R/W	PFKey	hex	4	0x00000000	0xffffffff	—	
0x63	R/W	AuthenKey3	hex	4	0x00000000	0xffffffff	—	
0x64	R/W	AuthenKey2	hex	4	0x00000000	0xffffffff	—	
0x65	R/W	AuthenKey1	hex	4	0x00000000	0xffffffff	—	
0x66	R/W	AuthenKey0	hex	4	0x00000000	0xffffffff	—	
0x70	R/W	ManufacturerInfo	String	8+1	—	—	—	ASCII
0x71	R/W	SenseResistor	unsigned int	2	0	65535	—	$\mu\Omega$
0x77	R/W	DataFlashSubClassID	hex	2	0x0000	0xffff	—	
0x78	R/W	DataFlashSubClassPage1	hex	32	—	—	—	
0x79	R/W	DataFlashSubClassPage2	hex	32	—	—	—	
0x7a	R/W	DataFlashSubClassPage3	hex	32	—	—	—	
0x7b	R/W	DataFlashSubClassPage4	hex	32	—	—	—	
0x7c	R/W	DataFlashSubClassPage5	hex	32	—	—	—	
0x7d	R/W	DataFlashSubClassPage6	hex	32	—	—	—	
0x7e	R/W	DataFlashSubClassPage7	hex	32	—	—	—	
0x7f	R/W	DataFlashSubClassPage8	hex	32	—	—	—	

PACKAGING INFORMATION

Orderable Device	Status (1)	Package Type	Package Drawing	Pins	Package Qty	Eco Plan (2)	Lead/Ball Finish (6)	MSL Peak Temp (3)	Op Temp (°C)	Device Marking (4/5)	Samples
BQ20Z90DBT-V150	NRND	TSSOP	DBT	30	60	Green (RoHS & no Sb/Br)	CU NIPDAU	Level-2-260C-1 YEAR	-40 to 85	BQ20Z90	
BQ20Z90DBTR-V150	NRND	TSSOP	DBT	30	2000	Green (RoHS & no Sb/Br)	CU NIPDAU	Level-2-260C-1 YEAR	-40 to 85	BQ20Z90	
HPA00742DBTR	NRND	TSSOP	DBT	30	2000	Green (RoHS & no Sb/Br)	CU NIPDAU	Level-2-260C-1 YEAR	-40 to 85	BQ20Z90	

(1) The marketing status values are defined as follows:

ACTIVE: Product device recommended for new designs.

LIFEBUY: TI has announced that the device will be discontinued, and a lifetime-buy period is in effect.

NRND: Not recommended for new designs. Device is in production to support existing customers, but TI does not recommend using this part in a new design.

PREVIEW: Device has been announced but is not in production. Samples may or may not be available.

OBSOLETE: TI has discontinued the production of the device.

(2) **RoHS:** TI defines "RoHS" to mean semiconductor products that are compliant with the current EU RoHS requirements for all 10 RoHS substances, including the requirement that RoHS substance do not exceed 0.1% by weight in homogeneous materials. Where designed to be soldered at high temperatures, "RoHS" products are suitable for use in specified lead-free processes. TI may reference these types of products as "Pb-Free".

RoHS Exempt: TI defines "RoHS Exempt" to mean products that contain lead but are compliant with EU RoHS pursuant to a specific EU RoHS exemption.

Green: TI defines "Green" to mean the content of Chlorine (Cl) and Bromine (Br) based flame retardants meet JS709B low halogen requirements of <=1000ppm threshold. Antimony trioxide based flame retardants must also meet the <=1000ppm threshold requirement.

(3) MSL, Peak Temp. - The Moisture Sensitivity Level rating according to the JEDEC industry standard classifications, and peak solder temperature.

(4) There may be additional marking, which relates to the logo, the lot trace code information, or the environmental category on the device.

(5) Multiple Device Markings will be inside parentheses. Only one Device Marking contained in parentheses and separated by a "~" will appear on a device. If a line is indented then it is a continuation of the previous line and the two combined represent the entire Device Marking for that device.

(6) Lead/Ball Finish - Orderable Devices may have multiple material finish options. Finish options are separated by a vertical ruled line. Lead/Ball Finish values may wrap to two lines if the finish value exceeds the maximum column width.

Important Information and Disclaimer: The information provided on this page represents TI's knowledge and belief as of the date that it is provided. TI bases its knowledge and belief on information provided by third parties, and makes no representation or warranty as to the accuracy of such information. Efforts are underway to better integrate information from third parties. TI has taken and continues to take reasonable steps to provide representative and accurate information but may not have conducted destructive testing or chemical analysis on incoming materials and chemicals. TI and TI suppliers consider certain information to be proprietary, and thus CAS numbers and other limited information may not be available for release.

In no event shall TI's liability arising out of such information exceed the total purchase price of the TI part(s) at issue in this document sold by TI to Customer on an annual basis.

DBT (R-PDSO-G30)

PLASTIC SMALL OUTLINE

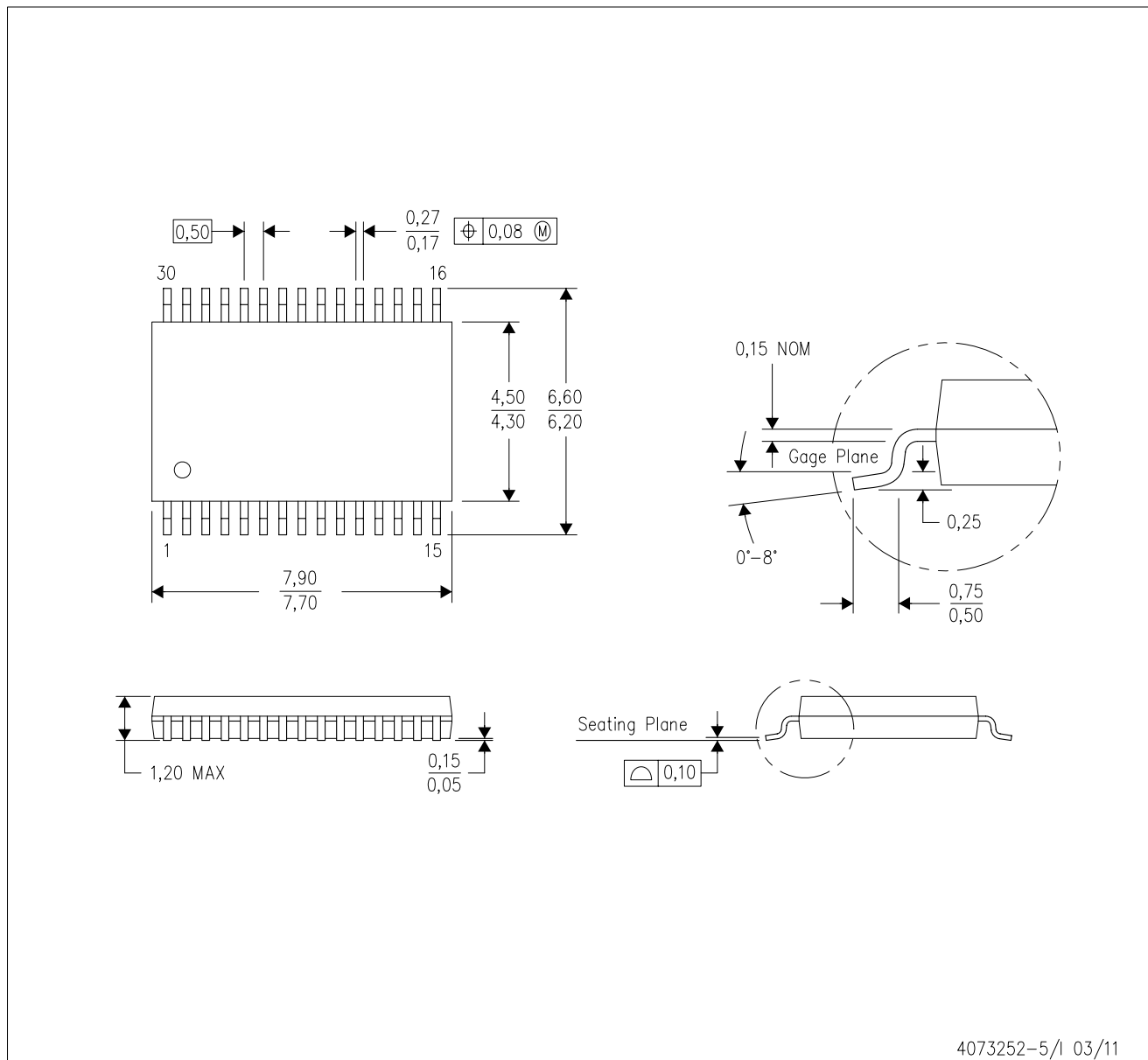

- NOTES:
- A. All linear dimensions are in millimeters. Dimensioning and tolerancing per ASME Y14.5M-1994.
 - B. This drawing is subject to change without notice.
 - C. Body dimensions do not include mold flash or protrusion.
 - D. Falls within JEDEC MO-153.

IMPORTANT NOTICE

Texas Instruments Incorporated (TI) reserves the right to make corrections, enhancements, improvements and other changes to its semiconductor products and services per JESD46, latest issue, and to discontinue any product or service per JESD48, latest issue. Buyers should obtain the latest relevant information before placing orders and should verify that such information is current and complete.

TI's published terms of sale for semiconductor products (<http://www.ti.com/sc/docs/stdterms.htm>) apply to the sale of packaged integrated circuit products that TI has qualified and released to market. Additional terms may apply to the use or sale of other types of TI products and services.

Reproduction of significant portions of TI information in TI data sheets is permissible only if reproduction is without alteration and is accompanied by all associated warranties, conditions, limitations, and notices. TI is not responsible or liable for such reproduced documentation. Information of third parties may be subject to additional restrictions. Resale of TI products or services with statements different from or beyond the parameters stated by TI for that product or service voids all express and any implied warranties for the associated TI product or service and is an unfair and deceptive business practice. TI is not responsible or liable for any such statements.

Buyers and others who are developing systems that incorporate TI products (collectively, "Designers") understand and agree that Designers remain responsible for using their independent analysis, evaluation and judgment in designing their applications and that Designers have full and exclusive responsibility to assure the safety of Designers' applications and compliance of their applications (and of all TI products used in or for Designers' applications) with all applicable regulations, laws and other applicable requirements. Designer represents that, with respect to their applications, Designer has all the necessary expertise to create and implement safeguards that (1) anticipate dangerous consequences of failures, (2) monitor failures and their consequences, and (3) lessen the likelihood of failures that might cause harm and take appropriate actions. Designer agrees that prior to using or distributing any applications that include TI products, Designer will thoroughly test such applications and the functionality of such TI products as used in such applications.

TI's provision of technical, application or other design advice, quality characterization, reliability data or other services or information, including, but not limited to, reference designs and materials relating to evaluation modules, (collectively, "TI Resources") are intended to assist designers who are developing applications that incorporate TI products; by downloading, accessing or using TI Resources in any way, Designer (individually or, if Designer is acting on behalf of a company, Designer's company) agrees to use any particular TI Resource solely for this purpose and subject to the terms of this Notice.

TI's provision of TI Resources does not expand or otherwise alter TI's applicable published warranties or warranty disclaimers for TI products, and no additional obligations or liabilities arise from TI providing such TI Resources. TI reserves the right to make corrections, enhancements, improvements and other changes to its TI Resources. TI has not conducted any testing other than that specifically described in the published documentation for a particular TI Resource.

Designer is authorized to use, copy and modify any individual TI Resource only in connection with the development of applications that include the TI product(s) identified in such TI Resource. NO OTHER LICENSE, EXPRESS OR IMPLIED, BY ESTOPPEL OR OTHERWISE TO ANY OTHER TI INTELLECTUAL PROPERTY RIGHT, AND NO LICENSE TO ANY TECHNOLOGY OR INTELLECTUAL PROPERTY RIGHT OF TI OR ANY THIRD PARTY IS GRANTED HEREIN, including but not limited to any patent right, copyright, mask work right, or other intellectual property right relating to any combination, machine, or process in which TI products or services are used. Information regarding or referencing third-party products or services does not constitute a license to use such products or services, or a warranty or endorsement thereof. Use of TI Resources may require a license from a third party under the patents or other intellectual property of the third party, or a license from TI under the patents or other intellectual property of TI.

TI RESOURCES ARE PROVIDED "AS IS" AND WITH ALL FAULTS. TI DISCLAIMS ALL OTHER WARRANTIES OR REPRESENTATIONS, EXPRESS OR IMPLIED, REGARDING RESOURCES OR USE THEREOF, INCLUDING BUT NOT LIMITED TO ACCURACY OR COMPLETENESS, TITLE, ANY EPIDEMIC FAILURE WARRANTY AND ANY IMPLIED WARRANTIES OF MERCHANTABILITY, FITNESS FOR A PARTICULAR PURPOSE, AND NON-INFRINGEMENT OF ANY THIRD PARTY INTELLECTUAL PROPERTY RIGHTS. TI SHALL NOT BE LIABLE FOR AND SHALL NOT DEFEND OR INDEMNIFY DESIGNER AGAINST ANY CLAIM, INCLUDING BUT NOT LIMITED TO ANY INFRINGEMENT CLAIM THAT RELATES TO OR IS BASED ON ANY COMBINATION OF PRODUCTS EVEN IF DESCRIBED IN TI RESOURCES OR OTHERWISE. IN NO EVENT SHALL TI BE LIABLE FOR ANY ACTUAL, DIRECT, SPECIAL, COLLATERAL, INDIRECT, PUNITIVE, INCIDENTAL, CONSEQUENTIAL OR EXEMPLARY DAMAGES IN CONNECTION WITH OR ARISING OUT OF TI RESOURCES OR USE THEREOF, AND REGARDLESS OF WHETHER TI HAS BEEN ADVISED OF THE POSSIBILITY OF SUCH DAMAGES.

Unless TI has explicitly designated an individual product as meeting the requirements of a particular industry standard (e.g., ISO/TS 16949 and ISO 26262), TI is not responsible for any failure to meet such industry standard requirements.

Where TI specifically promotes products as facilitating functional safety or as compliant with industry functional safety standards, such products are intended to help enable customers to design and create their own applications that meet applicable functional safety standards and requirements. Using products in an application does not by itself establish any safety features in the application. Designers must ensure compliance with safety-related requirements and standards applicable to their applications. Designer may not use any TI products in life-critical medical equipment unless authorized officers of the parties have executed a special contract specifically governing such use. Life-critical medical equipment is medical equipment where failure of such equipment would cause serious bodily injury or death (e.g., life support, pacemakers, defibrillators, heart pumps, neurostimulators, and implantables). Such equipment includes, without limitation, all medical devices identified by the U.S. Food and Drug Administration as Class III devices and equivalent classifications outside the U.S.

TI may expressly designate certain products as completing a particular qualification (e.g., Q100, Military Grade, or Enhanced Product). Designers agree that it has the necessary expertise to select the product with the appropriate qualification designation for their applications and that proper product selection is at Designers' own risk. Designers are solely responsible for compliance with all legal and regulatory requirements in connection with such selection.

Designer will fully indemnify TI and its representatives against any damages, costs, losses, and/or liabilities arising out of Designer's non-compliance with the terms and provisions of this Notice.

Looking for pricing, stock, or lifecycle information?

Click below to explore more details on WIN SOURCE:

 [View BQ20Z90DBTR-V150 on WIN SOURCE](#)

 [Texas Instruments](#) Information

Optimize Your Supply Chain with WIN SOURCE Solutions

-  Global Sourcing Solution
-  Obsolete Management
-  Cost Control Management
-  Shortage Management
-  Alternative Solution
-  Excess Inventory Management