



**THE DATASHEET OF  
BQ20Z90DBTR-V110**



---

## SBS 1.1-COMPLIANT GAS GAUGE ENABLED WITH IMPEDANCE TRACK™ TECHNOLOGY FOR USE WITH THE bq29330

---

### FEATURES

- Patented Impedance Track™ Technology Accurately Measures Available Charge in Li-Ion and Li-Polymer Batteries
- Better than 1% Error Over Lifetime of the Battery
- Instant Accuracy – No Learning Cycle Required
- Automatically adjusts for battery aging, battery self discharge and temperature inefficiencies
- Supports the Smart Battery Specification SBS V1.1
- Works With the TI bq29330 Analog Front-End (AFE) Protection IC to Provide Complete Pack Electronics Solution
- Full Array of Programmable Voltage, Current, and Temperature Protection Features
- Integrated Time Base Removes Need for External Crystal with Optional Crystal Input
- Electronics for 7.2-V, 10.8-V or 14.4-V Battery Packs With 50% Fewer External Components
- Based on a Powerful Low-Power RISC CPU Core With High-Performance Peripherals
- Integrated Field Programmable FLASH Memory Eliminates the Need for External Configuration Memory
- Measures Charge Flow Using a High-Resolution, 16-Bit Integrating Delta-Sigma Converter
  - Better Than 0.65 nVh of Resolution
  - Self-Calibrating
- Uses 16-Bit Delta-Sigma Converter for Accurate Voltage and Temperature Measurements
- Extensive Data Reporting Options For

### Improved System Interaction

- Optional Pulse Charging Feature for Improved Charge Times
- Drives 3-, 4- or 5-Segment LED Display for Remaining Capacity Indication
- Supports SHA-1 Authentication
- Lifetime Data Logging
- 30-Pin TSSOP (DBT)

### APPLICATIONS

- Notebook PCs
- Medical and Test Equipment
- Portable Instrumentation

### DESCRIPTION

The bq20z90-V110 SBS-compliant gas gauge IC, incorporating patented Impedance Track™ technology, is designed for battery-pack or in-system installation. The bq20z90-V110 measures and maintains an accurate record of available charge in Li-ion or Li-polymer batteries using its integrated high-performance analog peripherals. The bq20z90-V110 monitors capacity change, battery impedance, open-circuit voltage, and other critical parameters of the battery pack, and reports the information to the system host controller over a serial-communication bus. It is designed to work with the bq29330 analog front-end (AFE) protection IC to maximize functionality and safety, and minimize component count and cost in smart battery circuits.

The Impedance Track technology continuously analyzes the battery impedance, resulting in superior gas-gauging accuracy. This enables remaining capacity to be calculated with discharge rate, temperature, and cell aging all accounted for during each stage of every cycle.



Please be aware that an important notice concerning availability, standard warranty, and use in critical applications of Texas Instruments semiconductor products and disclaimers thereto appears at the end of this data sheet.

IMPEDANCE TRACK is a trademark of Texas Instruments.

**AVAILABLE OPTIONS**

T <sub>A</sub>	PACKAGE	
	30-PIN TSSOP (DBT) Tube	30-PIN TSSOP (DBT) Tape & Reel
-40°C to 85°C	bq20z90DBT <sup>(1)</sup>	bq20z90DBTR <sup>(2)</sup>

- (1) A single tube quantity is 50 units.
- (2) A single reel quantity is 2000 units

**SYSTEM PARTITIONING DIAGRAM**

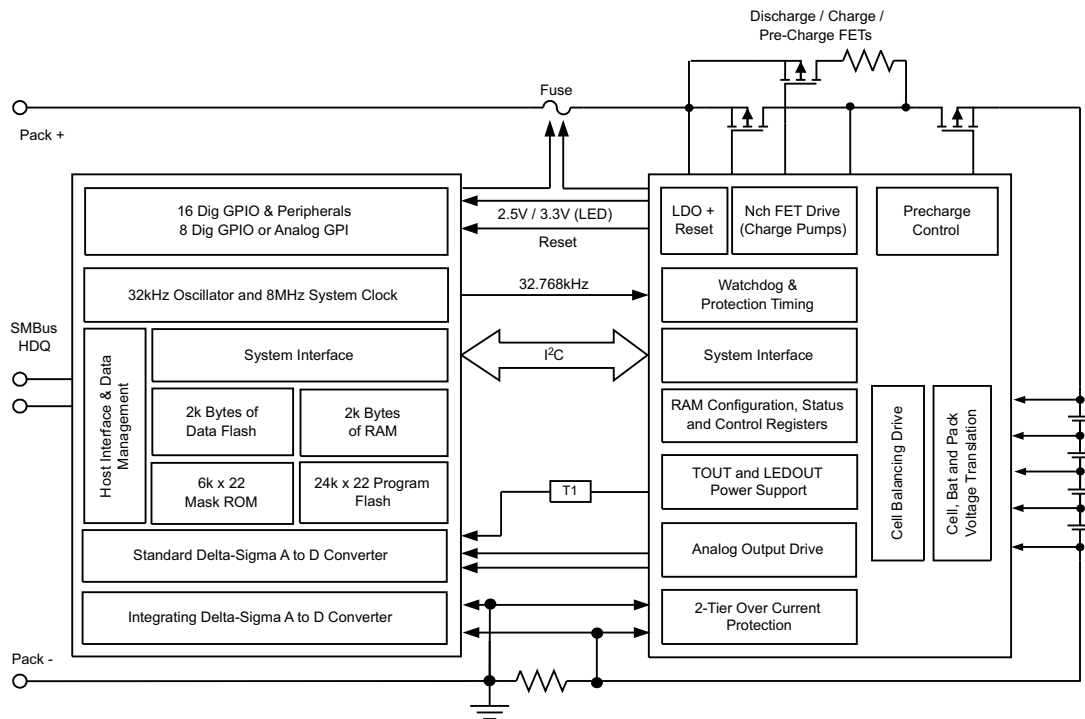

**TSSOP (DBT)  
(TOP VIEW)**

NC	1	30	VCELL-
XALERT	2	29	VCELL+
SDATA	3	28	NC
SCLK	4	27	RBI
CLKOUT	5	26	VCC
TS1	6	25	VSS
TS2	7	24	MRST
PRES	8	23	SRN
PFIN	9	22	SRP
SAFE	10	21	*VSS
SMBD	11	20	LED5
NC	12	19	LED4
SMBC	13	18	LED3
DISP	14	17	LED2
NC	15	16	LED1

NC - No internal connection

**TERMINAL FUNCTIONS**

TERMINAL		I/O <sup>(1)</sup>	DESCRIPTION
NO.	NAME		
1	NC	–	Not used— leave floating
2	XALERT	I	Input from bq29330 XALERT output.
3	SDATA	I/O	Data transfer to and from bq29330
4	SCLK	I/O	Communication clock to the bq29330
5	CLKOUT	O	32.768-kHz output for the bq29330. This pin should be directly connected to the AFE.
6	TS1	I	1 <sup>st</sup> Thermistor voltage input connection to monitor temperature
7	TS2	I	2 <sup>nd</sup> Thermistor voltage input connection to monitor temperature
8	PRES	I	Active low input to sense system insertion and typically requires additional ESD protection
9	PFIN	I	Active low input to detect secondary protector output status and allows the bq20z90-V110 to report the status of the 2 <sup>nd</sup> level protection output
10	SAFE	O	Active high output to enforce additional level of safety protection; e.g., fuse blow.
11	SMBD	I/OD	SMBus data open-drain bidirectional pin used to transfer address and data to and from the bq20z90
12	NC	–	Not used— leave floating
13	SMBC	I/OD	SMBus clock open-drain bidirectional pin used to clock the data transfer to and from the bq20z90
14	$\overline{\text{DISP}}$	I	Display control for the LEDs. This pin is typically connected to bq29330 REG via a 100-k $\Omega$ resistor and a push-button switch to VSS.
15	NC	–	Not used— leave floating
16	LED1	O	LED1 display segment that drives an external LED depending on the firmware configuration
17	LED2	O	LED2 display segment that drives an external LED depending on the firmware configuration
18	LED3	O	LED3 display segment that drives an external LED depending on the firmware configuration
19	LED4	O	LED4 display segment that drives an external LED depending on the firmware configuration
20	LED5	O	LED5 display segment that drives an external LED depending on the firmware configuration
21	VSS	–	Connected I/O pin to VSS
22	SRP	IA	Connections to the top of a small-value sense resistor to monitor the battery charge- and discharge-current flow
23	SRN	IA	Connections to the bottom of a small-value sense resistor to monitor the battery charge- and discharge-current flow
24	$\overline{\text{MRST}}$	I	Master reset input that forces the device into reset when held low. Must be held high for normal operation
25	VSS	P	Negative Supply Voltage
26	VCC	P	Positive Supply Voltage
27	RBI	P	Backup power to the bq20z90-V110 data registers during periods of low operating voltage. RBI accepts a storage capacitor or a battery input.
28	NC	–	Not used— leave floating
29	VCELL+	I	Input from bq29330 used to read a scaled value of individual cell voltages
30	VCELL-	I	Input from bq29330 used to read a scaled value of individual cell voltages

(1) I = Input, IA = Analog input, I/O = Input/output, I/OD = Input/Open-drain output, O = Output, OA = Analog output, P = Power

## ABSOLUTE MAXIMUM RATINGS

over operating free-air temperature range (unless otherwise noted)<sup>(1)</sup>

		RANGE
$V_{CC}$ relative to $V_{SS}$	Supply voltage range	-0.3 V to 2.75 V
$V_{(IOD)}$ relative to $V_{SS}$	Open-drain I/O pins	-0.3 V to 6 V
$V_I$ relative to $V_{SS}$	Input voltage range to all other pins	-0.3 V to $V_{CC} + 0.3$ V
$T_A$	Operating free-air temperature range	-40°C to 85°C
$T_{stg}$	Storage temperature range	-65°C to 150°C

(1) Stresses beyond those listed under absolute maximum ratings may cause permanent damage to the device. These are stress ratings only, and functional operation of the device at these or any other conditions beyond those indicated under recommended operating conditions is not implied. Exposure to absolute-maximum-rated conditions for extended periods may affect device reliability.

## ELECTRICAL CHARACTERISTICS

$V_{CC} = 2.4$  V to 2.6 V,  $T_A = -40^\circ\text{C}$  to  $85^\circ\text{C}$  (unless otherwise noted)

PARAMETER		TEST CONDITIONS	MIN	TYP	MAX	UNIT
$V_{CC}$	Supply voltage		2.4	2.5	2.6	V
$I_{CC}$	Operating mode current	No flash programming		400 <sup>(1)</sup>		$\mu\text{A}$
		bq20z90-V110 + bq29330		475		
$I_{(SLP)}$	Low-power storage mode current	Sleep mode		8 <sup>(1)</sup>		$\mu\text{A}$
		bq20z90-V110 + bq29330		51		
$V_{OL}$	Output voltage low SMBC, SMBD, SDATA, SCLK, SAFE	$I_{OL} = 0.5$ mA			0.4	V
	LED1 – LED5	$I_{OL} = 10$ mA			0.4	V
$V_{OH}$	Output high voltage, SMBC, SMBD, SDATA, SCLK, SAFE	$I_{OH} = -1$ mA	$V_{CC} - 0.5$			V
$V_{IL}$	Input voltage low SMBC, SMBD, SDATA, SCLK, XALERT, PRES, PFIN		-0.3		0.8	V
		DISP		-0.3		0.8
$V_{IH}$	Input voltage high SMBC, SMBD, SDATA, SCLK, XALERT, PRES, PFIN		2		6	V
		DISP	2		$V_{CC} + 0.3$	V
$C_{IN}$	Input capacitance			5		pF
$V_{(AI1)}$	Input voltage range VCELL+, VCELL-, TS1, TS2		-0.2		$0.8V_{CC}$	V
$V_{(AI2)}$	Input voltage range SR1, SR2		-0.20		0.20	
$Z_{(AI2)}$	Input impedance VCELL+, VCELL-, TS1, TS2	0 V–1 V		8		$\text{M}\Omega$
$Z_{(AI1)}$	Input impedance SR1, SR2	0 V–1 V		2.5		$\text{M}\Omega$

(1) This value does not include the bq29330

## POWER-ON RESET

$V_{CC} = 2.4V$  to  $2.6V$ ,  $T_A = -40^\circ C$  to  $85^\circ C$  (unless otherwise noted)

PARAMETER	TEST CONDITIONS	MIN	TYP	MAX	UNIT
$V_{IT-}$ Negative-going voltage input		1.7	1.8	1.9	V
$V_{HYS}$ Power-on reset hysteresis		50	125	200	mV

POWER ON RESET BEHAVIOR  
VS  
FREE-AIR TEMPERATURE

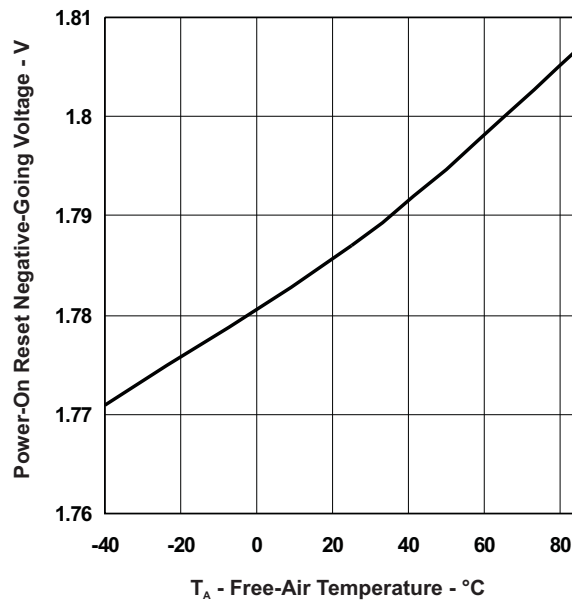

## INTEGRATING ADC (Coulomb Counter) CHARACTERISTICS

$V_{CC} = 2.4V$  to  $2.6V$ ,  $T_A = -40^\circ C$  to  $85^\circ C$  (unless otherwise noted)

PARAMETER	TEST CONDITIONS	MIN	TYP	MAX	UNIT
$V_{(SR)}$ Input voltage range, $V_{(SRN)}$ and $V_{(SRP)}$	$V_{(SR)} = V_{(SRN)} - V_{(SRP)}$	-0.2		0.2	V
$V_{(SROS)}$ Input offset			10		$\mu V$
INL Integral nonlinearity error			0.007%	0.034%	

## OSCILLATOR

$V_{CC} = 2.4V$  to  $2.6V$ ,  $T_A = -40^\circ C$  to  $85^\circ C$  (unless otherwise noted)

PARAMETER	TEST CONDITIONS	MIN	TYP	MAX	UNIT
<b>HIGH FREQUENCY OSCILLATOR</b>					
$f_{(OSC)}$ Operating Frequency				4.194	MHz
$f_{(EIO)}$ Frequency Error <sup>(1)(2)</sup>		-3%	0.25%	3%	
	$T_A = 20^\circ C$ to $70^\circ C$	-2%	0.25%	2%	
$t_{(SXO)}$ Start-up Time <sup>(3)</sup>			2.5	5	ms
<b>LOW FREQUENCY OSCILLATOR</b>					
$f_{(LOSC)}$ Operating Frequency			32.768		KHz
$f_{(LEIO)}$ Frequency Error <sup>(2)(4)</sup>		-2.5%	0.25%	2.5%	
	$T_A = 20^\circ C$ to $70^\circ C$	-1.5%	0.25%	1.5%	

(1) The frequency error is measured from 4.194 MHz.

(2) The frequency drift is included and measured from the trimmed frequency at  $V_{CC} = 2.5V$ ,  $T_A = 25^\circ C$ .

(3) The start-up time is defined as the time it takes for the oscillator output frequency to be within 1% of the specified frequency.

(4) The frequency error is measured from 32.768 kHz.

**OSCILLATOR (continued)**
 $V_{CC} = 2.4\text{ V to }2.6\text{ V}$ ,  $T_A = -40^\circ\text{C to }85^\circ\text{C}$  (unless otherwise noted)

PARAMETER	TEST CONDITIONS	MIN	TYP	MAX	UNIT
$t_{(LSXO)}$ Start-up time <sup>(5)</sup>				500	$\mu\text{s}$

(5) The start-up time is defined as the time it takes for the oscillator output frequency to be  $\pm 3\%$ .

**DATA FLASH MEMORY CHARACTERISTICS**
 $V_{CC} = 2.4\text{ V to }2.6\text{ V}$ ,  $T_A = -40^\circ\text{C to }85^\circ\text{C}$  (unless otherwise noted)

PARAMETER	TEST CONDITIONS	MIN	TYP	MAX	UNIT
$t_{DR}$ Data retention	See <sup>(1)</sup>	10			Years
Flash programming write-cycles	See <sup>(1)</sup>	20,000			Cycles
$t_{(WORDPROG)}$ Word programming time	See <sup>(1)</sup>			2	ms
$I_{(DDdPROG)}$ Flash-write supply current	See <sup>(1)</sup>		5	10	mA

(1) Assured by design. Not production tested

**REGISTER BACKUP**
 $V_{CC} = 2.4\text{ V to }2.6\text{ V}$ ,  $T_A = -40^\circ\text{C to }85^\circ\text{C}$  (unless otherwise noted)

PARAMETER	TEST CONDITIONS	MIN	TYP	MAX	UNIT
$I_{(RB)}$ RB data-retention input current	$V_{(RB)} > V_{(RBMIN)}$ , $V_{CC} < V_{IT-}$			1500	nA
	$V_{(RB)} > V_{(RBMIN)}$ , $V_{CC} < V_{IT-}$ , $T_A = 0^\circ\text{C to }50^\circ\text{C}$		40	160	
$V_{(RB)}$ RB data-retention voltage <sup>(1)</sup>		1.7			V

(1) Specified by design. Not production tested.

## SMBus TIMING SPECIFICATIONS

$V_{CC} = 2.4\text{ V to }2.6\text{ V}$ ,  $T_A = -40^\circ\text{C to }85^\circ\text{C}$  (unless otherwise noted)

PARAMETER		TEST CONDITIONS	MIN	TYP	MAX	UNIT
$f_{SMB}$	SMBus operating frequency	Slave mode, SMBC 50% duty cycle	10		100	kHz
$f_{MAS}$	SMBus master clock frequency	Master mode, no clock low slave extend		51.2		
$t_{BUF}$	Bus free time between start and stop		4.7			$\mu\text{s}$
$t_{HD:STA}$	Hold time after (repeated) start		4			
$t_{SU:STA}$	Repeated start setup time		4.7			
$t_{SU:STO}$	Stop setup time		4			
$t_{HD:DAT}$	Data hold time	Receive mode	0			
		Transmit mode	300			
$t_{SU:DAT}$	Data setup time		250			
$t_{TIMEOUT}$	Error signal/detect	See (1)	25		35	ms
$t_{LOW}$	Clock low period		4.7			$\mu\text{s}$
$t_{HIGH}$	Clock high period	See (2)	4		50	
$t_{LOW:SEXT}$	Cumulative clock low slave extend time	See (3)			25	ms
$t_{LOW:MEXT}$	Cumulative clock low master extend time	See (4)			10	
$t_F$	Clock/data fall time	$(V_{ILMAX} - 0.15\text{ V})$ to $(V_{IHMIN} + 0.15\text{ V})$			300	ns
$t_R$	Clock/data rise time	$0.9\text{ VCC to } (V_{ILMAX} - 0.15\text{ V})$			1000	

- (1) The bq20z90-V110 times out when any clock low exceeds  $t_{TIMEOUT}$ .
- (2)  $t_{HIGH:MAX}$  is minimum bus idle time. SMBC = 1 for  $t > 50\ \mu\text{s}$  causes reset of any transaction involving the bq20z90-V110 that is in progress.
- (3)  $t_{LOW:SEXT}$  is the cumulative time a slave device is allowed to extend the clock cycles in one message from initial start to the stop.
- (4)  $t_{LOW:MEXT}$  is the cumulative time a master device is allowed to extend the clock cycles in one message from initial start to the stop.

### SMBus TIMING DIAGRAM

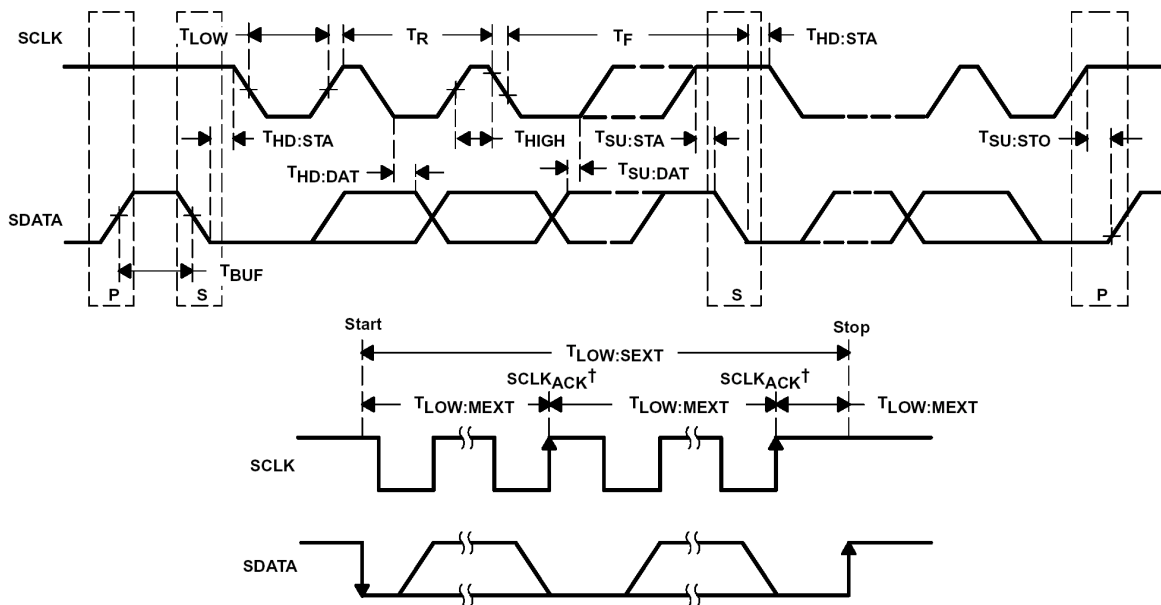

† SCLK<sub>ACK</sub> is the acknowledge-related clock pulse generated by the master.

## FEATURE SET

### Primary (1st Level) Safety Features

The bq20z90-V110 supports a wide range of battery and system protection features that can easily be configured. The primary safety features include:

- Battery cell over/under voltage protection
- Battery pack over/under voltage protection
- 2 independent charge overcurrent protection
- 3 independent discharge overcurrent protection
- Short circuit protection
- Over temperature protection
- AFE Watchdog
- Host Watchdog

### Secondary (2nd Level) Safety Features

The secondary safety features of the bq20z90-V110 can be used to indicate more serious faults via the SAFE (pin 10) pin. This pin can be used to blow an in-line fuse to permanently disable the battery pack from charging or discharging. The secondary safety features include:

- Safety over voltage
- Battery cell imbalance
- 2nd level protection IC input
- Safety over current
- Safety over temperature
- Open thermistor
- Charge FET and Zero-Volt Charge FET fault
- Discharge FET fault
- Fuse blow failure detection
- AFE Communication error
- AFE Verification error
- Internal flash data error

### Charge Control Features

The bq20z90-V110 charge control features include:

- Report the appropriate charging current needed for constant current charging and the appropriate charging voltage needed for constant voltage charging to a smart charger using SMBus broadcasts.
- Determine the chemical state of charge of each battery cell using Impedance Track™. Using cell balancing algorithm, gradually decrease the differences in the cells' state of charge in a fully charged state. This prevents high cells from overcharging, causing excessive degradation and also increases the usable pack energy by preventing early charge termination.
- Support Pre-charging/Zero-volt charging
- Support Fast charging
- Support Pulse charging
- Support Charge Inhibit and Charge Suspend modes
- Report charging faults and also indicate charging status via charge and discharge alarms.

### Gas Gauging

The bq20z90-V110 uses the Impedance Track™ Technology to measure and calculate the available charge in battery cells. The achievable accuracy is better than 1% error over the lifetime of the battery and there is no full charge-discharge learning cycle required.

---

## FEATURE SET (continued)

See *Theory and Implementation of Impedance Track Battery Fuel-Gauging Algorithm* application note (SLUA364) for further details.

### LED Display

The bq20z90-V110 can drive a 3-, 4-, or 5- segment LED display for remaining capacity indication. The LED drive current can be adjusted to 3mA, 4mA and 5mA digitally.

### LifeTime Data Logging Features

The bq20z90-V110 offers a lifetime data logging array, where all important measurements are stored for warranty and analysis purposes. The data monitored include:

- Lifetime maximum temperature
- Lifetime minimum temperature
- Lifetime maximum battery cell voltage
- Lifetime minimum battery cell voltage
- Lifetime maximum battery pack voltage
- Lifetime minimum battery pack voltage
- Lifetime maximum charge current
- Lifetime maximum discharge current
- Lifetime maximum charge power
- Lifetime maximum discharge power
- Lifetime maximum average discharge current
- Lifetime maximum average discharge power
- Lifetime average temperature

### Authentication

The bq20z90-V110 supports authentication by the host using SHA-1.

### Power Modes

The bq20z90-V110 supports 3 different power modes to reduce power consumption:

- In Normal Mode, the bq20z90-V110 performs measurements, calculations, protection decisions, and data updates in 1 second intervals. Between these intervals, the bq20z90-V110 is in a reduced power stage.
- In Sleep Mode, the bq20z90-V110 performs measurements, calculations, protection decisions, and data updates in adjustable time intervals. Between these intervals, the bq20z90-V110 is in a reduced power stage.
- In Shutdown Mode the bq20z90-V110 is completely disabled.

## CONFIGURATION

### Oscillator Function

The bq20z90-V110 fully integrates the system and processor oscillators and, therefore, requires no pins or components for this feature.

### System Present Operation

The bq20z90-V110 periodically verifies the  $\overline{\text{PRES}}$  pin and detects that the battery is present in the system via a low state on a  $\overline{\text{PRES}}$  input. When this occurs, bq20z90-V110 enters normal operating mode. When the pack is removed from the system and the  $\overline{\text{PRES}}$  input is high, the bq20z90-V110 enters the battery-removed state, disabling the charge, discharge and ZVCHG FETs. The  $\overline{\text{PRES}}$  input is ignored and can be left floating when non-removal mode is set in the data flash.

## FEATURE SET (continued)

### BATTERY PARAMETER MEASUREMENTS

The bq20z90-V110 uses an integrating delta-sigma analog-to-digital converter (ADC) for current measurement, and a second delta-sigma ADC for individual cell and battery voltage, and temperature measurement.

#### Charge and Discharge Counting

The integrating delta-sigma ADC measures the charge/discharge flow of the battery by measuring the voltage drop across a small-value sense resistor between the SRP and SRN pins. The integrating ADC measures bipolar signals from -0.25 V to 0.25 V. The bq20z90-V110 detects charge activity when  $V_{SR} = V_{(SRP)} - V_{(SRN)}$  is positive and discharge activity when  $V_{SR} = V_{(SRP)} - V_{(SRN)}$  is negative. The bq20z90-V110 continuously integrates the signal over time, using an internal counter. The fundamental rate of the counter is 0.65 nVh.

#### Voltage

The bq20z90-V110 updates the individual series cell voltages through the bq29330 at one second intervals. The bq20z90-V110 configures the bq29330 to connect the selected cell, cell offset, or bq29330 VREF to the CELL pin of the bq29330, which is required to be connected to VIN of the bq20z90. The internal ADC of the bq20z90-V110 measures the voltage, scales it, and calibrates itself appropriately. This data is also used to calculate the impedance of the cell for the Impedance Track™ gas-gauging.

#### Current

The bq20z90-V110 uses the SRP and SRN inputs to measure and calculate the battery charge and discharge current using a 5 mΩ to 20 mΩ typ. sense resistor.

#### Wake Function

The bq20z90-V110 can exit sleep mode, if enabled, by the presence of a programmable level of current signal across SRP and SRN.

#### Auto Calibration

The bq20z90-V110 provides an auto-calibration feature to cancel the voltage offset error across SRP and SRN for maximum charge measurement accuracy. The bq20z90-V110 performs auto-calibration when the SMBus lines stay low continuously for a minimum of a programmable amount of time.

#### Temperature

The bq20z90-V110 TS1 and TS2 inputs, in conjunction with two identical NTC thermistors (default are Semitec 103AT), measure the battery environmental temperature. The bq20z90-V110 can also be configured to use its internal temperature sensor.

### COMMUNICATIONS

The bq20z90-V110 uses SMBus v1.1 with Master Mode and package error checking (PEC) options per the SBS specification.

#### SMBus On and Off State

The bq20z90-V110 detects an SMBus off state when SMBC and SMBD are logic-low for  $\geq 2$  seconds. Clearing this state requires either SMBC or SMBD to transition high. Within 1 ms, the communication bus is available.

**Table 1. SBS COMMANDS**

SBS Cmd	Mode	Name	Format	Size in Bytes	Min Value	Max Value	Default Value	Unit
0x00	R/W	ManufacturerAccess	hex	2	0x0000	0xffff	—	
0x01	R/W	RemainingCapacityAlarm	unsigned int	2	0	65535	300	mAh or 10mWh
0x02	R/W	RemainingTimeAlarm	unsigned int	2	0	65535	10	min

**FEATURE SET (continued)**
**Table 1. SBS COMMANDS (continued)**

SBS Cmd	Mode	Name	Format	Size in Bytes	Min Value	Max Value	Default Value	Unit
0x03	R/W	BatteryMode	hex	2	0x0000	0xe383	—	
0x04	R/W	AtRate	signed int	2	-32768	32767	—	mA or 10mW
0x05	R	AtRateTimeToFull	unsigned int	2	0	65534	—	min
0x06	R	AtRateTimeToEmpty	unsigned int	2	0	65534	—	min
0x07	R	AtRateOK	unsigned int	2	0	65535	—	
0x08	R	Temperature	unsigned int	2	0	65535	—	0.1°K
0x09	R	Voltage	unsigned int	2	0	65535	—	mV
0x0a	R	Current	signed int	2	-32768	32767	—	mA
0x0b	R	AverageCurrent	signed int	2	-32768	32767	—	mA
0x0c	R	MaxError	unsigned int	1	0	100	—	%
0x0d	R	RelativeStateOfCharge	unsigned int	1	0	100	—	%
0x0e	R	AbsoluteStateOfCharge	unsigned int	1	0	100+	—	%
0x0f	R/W	RemainingCapacity	unsigned int	2	0	65535	—	mAh or 10mWh
0x10	R	FullChargeCapacity	unsigned int	2	0	65535	—	mAh or 10mWh
0x11	R	RunTimeToEmpty	unsigned int	2	0	65534	—	min
0x12	R	AverageTimeToEmpty	unsigned int	2	0	65534	—	min
0x13	R	AverageTimeToFull	unsigned int	2	0	65534	—	min
0x14	R	ChargingCurrent	unsigned int	2	0	65534	—	mA
0x15	R	ChargingVoltage	unsigned int	2	0	65534	—	mV
0x16	R	BatteryStatus	unsigned int	2	0x0000	0xdbff	—	
0x17	R/W	CycleCount	unsigned int	2	0	65535	—	
0x18	R/W	DesignCapacity	unsigned int	2	0	65535	4400	mAh or 10mWh
0x19	R/W	DesignVoltage	unsigned int	2	0	65535	14400	mV
0x1a	R/W	SpecificationInfo	hex	2	0x0000	0xffff	0x0031	
0x1b	R/W	ManufactureDate	unsigned int	2	—	—	01-Jan-1980	ASCII
0x1c	R/W	SerialNumber	hex	2	0x0000	0xffff	0x0001	
0x20	R/W	ManufacturerName	String	11+1	—	—	Texas Inst.	ASCII
0x21	R/W	DeviceName	String	7+1	—	—	bq20z90	ASCII
0x22	R/W	DeviceChemistry	String	4+1	—	—	LION	ASCII
0x23	R/W	ManufacturerData	String	14+1	—	—	—	ASCII
0x2f	R/W	Authenticate	String	20+1	—	—	—	ASCII
0x3c	R	CellVoltage4	unsigned int	2	0	65535	—	mV
0x3d	R	CellVoltage3	unsigned int	2	0	65535	—	mV
0x3e	R	CellVoltage2	unsigned int	2	0	65535	—	mV
0x3f	R	CellVoltage1	unsigned int	2	0	65535	—	mV

**Table 2. EXTENDED SBS COMMANDS**

SBS Cmd	Mode	Name	Format	Size in Bytes	Min Value	Max Value	Default Value	Unit
0x45	R	AFEDData	String	11+1	—	—	—	ASCII
0x46	R/W	FETControl	hex	1	0x00	0x1e	—	
0x4f	R	StateOfHealth	unsigned int	1	0	100	—	%
0x50	R	SafetyAlert	hex	2	0x0000	0xffff	—	

**Table 2. EXTENDED SBS COMMANDS (continued)**

SBS Cmd	Mode	Name	Format	Size in Bytes	Min Value	Max Value	Default Value	Unit
0x51	R	SafetyStatus	hex	2	0x0000	0xffff	—	
0x52	R	PFAAlert	hex	2	0x0000	0x9fff	—	
0x53	R	PFStatus	hex	2	0x0000	0x9fff	—	
0x54	R	OperationStatus	hex	2	0x0000	0xf7f7	—	
0x55	R	ChargingStatus	hex	2	0x0000	0xffff	—	
0x57	R	ResetData	hex	2	0x0000	0xffff	—	
0x58	R	WDRResetData	unsigned int	2	0	65535	—	
0x5a	R	PackVoltage	unsigned int	2	0	65535	---	mV
0x5d	R	AverageVoltage	unsigned int	2	0	65535	—	mV
0x60	R/W	UnSealKey	hex	4	0x00000000	0xffffffff	—	
0x61	R/W	FullAccessKey	hex	4	0x00000000	0xffffffff	—	
0x62	R/W	PFKey	hex	4	0x00000000	0xffffffff	—	
0x63	R/W	AuthenKey3	hex	4	0x00000000	0xffffffff	—	
0x64	R/W	AuthenKey2	hex	4	0x00000000	0xffffffff	—	
0x65	R/W	AuthenKey1	hex	4	0x00000000	0xffffffff	—	
0x66	R/W	AuthenKey0	hex	4	0x00000000	0xffffffff	—	
0x70	R/W	ManufacturerInfo	String	8+1	—	—	—	ASCII
0x71	R/W	SenseResistor	unsigned int	2	0	65535	—	$\mu\Omega$
0x77	R/W	DataFlashSubClassID	hex	2	0x0000	0xffff	—	
0x78	R/W	DataFlashSubClassPage1	hex	32	—	—	—	
0x79	R/W	DataFlashSubClassPage2	hex	32	—	—	—	
0x7a	R/W	DataFlashSubClassPage3	hex	32	—	—	—	
0x7b	R/W	DataFlashSubClassPage4	hex	32	—	—	—	
0x7c	R/W	DataFlashSubClassPage5	hex	32	—	—	—	
0x7d	R/W	DataFlashSubClassPage6	hex	32	—	—	—	
0x7e	R/W	DataFlashSubClassPage7	hex	32	—	—	—	
0x7f	R/W	DataFlashSubClassPage8	hex	32	—	—	—	

**NOTE:**

All reserved bits in data flash should be set to zero.

**Table 3. DATA FLASH VALUES**

Class	Subclass ID	Subclass	Offset	Name	Data Type	Min Value	Max Value	Default Value	Units
1st Level Safety	0	Voltage	0	COV Threshold	I2	3700	5000	4300	mV
1st Level Safety	0	Voltage	2	COV Time	U1	0	240	2	s
1st Level Safety	0	Voltage	3	COV Recovery	I2	0	4400	3900	mV
1st Level Safety	0	Voltage	5	COV Delta	U1	0	200	20	mV
1st Level Safety	0	Voltage	6	COV Temp. Hys	U1	0	250	100	0.1°C
1st Level Safety	0	Voltage	7	POV Threshold	I2	0	18000	17500	mV
1st Level Safety	0	Voltage	9	POV Time	U1	0	240	2	s
1st Level Safety	0	Voltage	10	POV Recovery	I2	0	17000	16000	mV
1st Level Safety	0	Voltage	12	CUV Threshold	I2	0	3500	2200	mV

**Table 3. DATA FLASH VALUES (continued)**

Class	Subclass ID	Subclass	Offset	Name	Data Type	Min Value	Max Value	Default Value	Units
1st Level Safety	0	Voltage	14	CUV Time	U1	0	240	2	s
1st Level Safety	0	Voltage	15	CUV Recovery	I2	0	3600	3000	mV
1st Level Safety	0	Voltage	17	PUV Threshold	I2	0	16000	11000	mV
1st Level Safety	0	Voltage	19	PUV Time	U1	0	240	2	s
1st Level Safety	0	Voltage	20	PUV Recovery	I2	0	16000	12000	mV
1st Level Safety	1	Current	0	OC (1st Tier) Chg	I2	0	20000	6000	mA
1st Level Safety	1	Current	2	OC (1st Tier) Chg Time	U1	0	240	2	s
1st Level Safety	1	Current	3	OC Chg Recovery	I2	-1000	1000	200	mA
1st Level Safety	1	Current	5	OC (1st Tier) Dsg	I2	0	20000	6000	mA
1st Level Safety	1	Current	7	OC (1st Tier) Dsg Time	U1	0	240	2	s
1st Level Safety	1	Current	8	OC Dsg Recovery	I2	0	1000	200	mA
1st Level Safety	1	Current	10	OC (2nd Tier) Chg	I2	0	20000	8000	mA
1st Level Safety	1	Current	12	OC (2nd Tier) Chg Time	U1	0	240	2	s
1st Level Safety	1	Current	13	OC (2nd Tier) Dsg	I2	0	22000	8000	mA
1st Level Safety	1	Current	15	OC (2nd Tier) Dsg Time	U1	0	240	2	s
1st Level Safety	1	Current	16	Current Recovery Time	U1	0	240	8	s
1st Level Safety	1	Current	17	AFE OC Dsg	H1	0x00	0x1f	0x12	
1st Level Safety	1	Current	18	AFE OC Dsg Time	H1	0x00	0x0f	0x0f	
1st Level Safety	1	Current	19	AFE OC Dsg Recovery	I2	10	1000	5	mA
1st Level Safety	1	Current	21	AFE SC Chg Cfg	H1	0x00	0xff	0x77	
1st Level Safety	1	Current	22	AFE SC Dsg Cfg	H1	0x00	0xff	0x77	
1st Level Safety	1	Current	23	AFE SC Recovery	I2	0	200	1	mA
1st Level Safety	2	Temperature	0	Over Temp Chg	I2	0	1200	550	0.1°C
1st Level Safety	2	Temperature	2	OT Chg Time	U1	0	240	2	s
1st Level Safety	2	Temperature	3	OT Chg Recovery	I2	0	1200	500	0.1°C
1st Level Safety	2	Temperature	5	Over Temp Dsg	I2	0	1200	600	0.1°C
1st Level Safety	2	Temperature	7	OT Dsg Time	U1	0	240	2	s
1st Level Safety	2	Temperature	8	OT Dsg Recovery	I2	0	1200	550	0.1°C
1st Level Safety	3	Host Comm	0	Host Watchdog Timeout	U1	0	255	0	s
2nd Level Safety	16	Voltage	0	SOV Threshold	I2	0	20000	18000	mV

**Table 3. DATA FLASH VALUES (continued)**

Class	Subclass ID	Subclass	Offset	Name	Data Type	Min Value	Max Value	Default Value	Units
2nd Level Safety	16	Voltage	2	SOV Time	U1	0	240	0	s
2nd Level Safety	16	Voltage	3	Cell Imbalance Current	I1	0	200	5	mA
2nd Level Safety	16	Voltage	4	Cell Imbalance Fail Voltage	I2	0	5000	1000	mV
2nd Level Safety	16	Voltage	6	Cell Imbalance Time	U1	0	240	0	s
2nd Level Safety	16	Voltage	7	Battery Rest Time	U2	0	65535	1800	s
2nd Level Safety	16	Voltage	9	PFIN Detect Time	U1	0	240	0	s
2nd Level Safety	17	Current	0	SOC Chg	I2	0	30000	10000	mA
2nd Level Safety	17	Current	2	SOC Chg Time	U1	0	240	0	s
2nd Level Safety	17	Current	3	SOC Dsg	I2	0	30000	10000	mA
2nd Level Safety	17	Current	5	SOC Dsg Time	U1	0	240	0	s
2nd Level Safety	18	Temperature	0	SOT Chg	I2	0	1200	650	0.1°C
2nd Level Safety	18	Temperature	2	SOT Chg Time	U1	0	240	0	s
2nd Level Safety	18	Temperature	3	SOT Dsg	I2	0	1200	750	0.1°C
2nd Level Safety	18	Temperature	5	SOT Dsg Time	U1	0	240	0	s
2nd Level Safety	18	Temperature	6	Open Thermistor	I2	-1000	1200	-333	0.1°C
2nd Level Safety	18	Temperature	8	Open Time	I1	0	240	0	s
2nd Level Safety	19	FET Verification	0	FET Fail Limit	I2	0	500	20	mA
2nd Level Safety	19	FET Verification	2	FET Fail Time	U1	0	240	0	s
2nd Level Safety	20	AFE Verification	0	AFE Check Time	U1	0	255	0	s
2nd Level Safety	20	AFE Verification	1	AFE Fail Limit	U1	0	255	10	
2nd Level Safety	20	AFE Verification	2	AFE Fail Recovery Time	U1	0	255	20	s
2nd Level Safety	20	AFE Verification	3	AFE Init Retry Limit	U1	0	255	6	
2nd Level Safety	20	AFE Verification	4	AFE Init Limit	U1	0	255	20	
2nd Level Safety	21	Fuse Verification	0	Fuse Fail Limit	I2	0	20	2	mA
2nd Level Safety	21	Fuse Verification	2	Fuse Fail Time	U1	0	240	0	s
Charge Control	32	Charge Inhibit Cfg	0	Chg Inhibit Temp Low	I2	-400	1200	0	0.1°C
Charge Control	32	Charge Inhibit Cfg	2	Chg Inhibit Temp High	I2	-400	1200	450	0.1°C
Charge Control	32	Charge Inhibit Cfg	4	Temp Hys	I2	0	100	10	0.1°C
Charge Control	33	Pre-Charge Cfg	0	Pre-chg Current	I2	0	2000	250	mA
Charge Control	33	Pre-Charge Cfg	2	Pre-chg Temp	I2	-400	1200	120	0.1°C
Charge Control	33	Pre-Charge Cfg	4	Pre-chg Voltage	I2	0	20000	3000	mV
Charge Control	33	Pre-Charge Cfg	6	Recovery Voltage	I2	0	20000	3100	mV
Charge Control	34	Fast Charge Cfg	0	Fast Charge Current	I2	0	10000	4000	mA
Charge Control	34	Fast Charge Cfg	2	Charging Voltage	I2	0	20000	16800	mV

**Table 3. DATA FLASH VALUES (continued)**

Class	Subclass ID	Subclass	Offset	Name	Data Type	Min Value	Max Value	Default Value	Units
Charge Control	34	Fast Charge Cfg	4	Delta Temp	I2	0	500	50	0.1°C
Charge Control	34	Fast Charge Cfg	6	Suspend Low Temp	I2	-400	1200	-50	0.1°C
Charge Control	34	Fast Charge Cfg	8	Suspend High Temp	I2	-400	1200	550	0.1°C
Charge Control	35	Pulse Charge Cfg	0	Turn ON Voltage	I2	0	5000	4150	mV
Charge Control	35	Pulse Charge Cfg	2	Turn OFF Voltage	I2	0	5000	4250	mV
Charge Control	35	Pulse Charge Cfg	4	Max ON Pulse Time	U1	0	240	240	Seconds/4
Charge Control	35	Pulse Charge Cfg	5	Min OFF Pulse Time	U1	0	240	0	Seconds/4
Charge Control	35	Pulse Charge Cfg	6	Max OFF Voltage	I2	0	5000	4270	mV
Charge Control	36	Termination Cfg.	0	Maintenance Current	I2	0	1000	0	mA
Charge Control	36	Termination Cfg.	2	Taper Current	I2	0	1000	250	mA
Charge Control	36	Termination Cfg.	6	Taper Voltage	I2	0	1000	300	mV
Charge Control	36	Termination Cfg.	8	Current Taper Window	U1	0	240	40	s
Charge Control	36	Termination Cfg.	9	TCA Set %	I1	-1	100	-1	%
Charge Control	36	Termination Cfg.	10	TCA Clear %	I1	-1	100	95	%
Charge Control	36	Termination Cfg.	11	FC Set %	I1	-1	100	-1	%
Charge Control	36	Termination Cfg.	12	FC Clear %	I1	-1	100	98	%
Charge Control	37	Cell Balancing Cfg	0	Min Cell Deviation	U2	0	65535	1750	s/mAh
Charge Control	38	Charging Faults	0	Over Charging Voltage	I2	0	3000	500	mV
Charge Control	38	Charging Faults	2	Over Charging Volt Time	U1	0	240	2	s
Charge Control	38	Charging Faults	3	Over Charging Current	I2	0	2000	500	mA
Charge Control	38	Charging Faults	5	Over Charging Curr Time	U1	0	240	2	s
Charge Control	38	Charging Faults	6	Over Charging Curr Recov	I2	0	2000	100	mA
Charge Control	38	Charging Faults	8	Depleted Voltage	I2	0	16000	8000	mV
Charge Control	38	Charging Faults	10	Depleted Voltage Time	U1	0	240	2	s
Charge Control	38	Charging Faults	11	Depleted Recovery	I2	0	16000	8500	mV
Charge Control	38	Charging Faults	13	Over Charge Capacity	I2	0	4000	300	mAh
Charge Control	38	Charging Faults	15	Over Charge Recovery	I2	0	100	2	mAh
Charge Control	38	Charging Faults	17	FC-MTO	U2	0	65535	10800	s
Charge Control	38	Charging Faults	19	PC-MTO	U2	0	65535	3600	s
Charge Control	38	Charging Faults	21	Charge Fault Cfg	H1	0x00	0x3f	0x00	
SBS Configuration	48	Data	0	Rem Cap Alarm	I2	0	700	300	mAh
SBS Configuration	48	Data	2	Rem Energy Alarm	I2	0	1000	432	10mW
SBS Configuration	48	Data	4	Rem Time Alarm	U2	0	30	10	min
SBS Configuration	48	Data	6	Init Battery Mode	H2	0x0000	0xffff	0x0081	
SBS Configuration	48	Data	8	Design Voltage	I2	7000	18000	14400	mV
SBS Configuration	48	Data	10	Spec Info	H2	0x0000	0xffff	0x0031	
SBS Configuration	48	Data	12	Manuf Date	U2	0	65535	0	Day + Mo*32 + (Yr - 1980)*256
SBS Configuration	48	Data	14	Ser. Num.	H2	0x0000	0xffff	0x0001	
SBS Configuration	48	Data	16	Cycle Count	U2	0	65535	0	Count
SBS Configuration	48	Data	18	CC Threshold	I2	100	32767	4400	mAh
SBS Configuration	48	Data	20	CC %	U1	0	100	90	%

**Table 3. DATA FLASH VALUES (continued)**

Class	Subclass ID	Subclass	Offset	Name	Data Type	Min Value	Max Value	Default Value	Units
SBS Configuration	48	Data	21	CF MaxError Limit	U1	0	100	100	%
SBS Configuration	48	Data	22	Design Capacity	I2	0	65535	4400	mAh
SBS Configuration	48	Data	24	Design Energy	I2	0	65535	6336	10mW
SBS Configuration	48	Data	26	Manuf Name	S12	-	-	Texas Inst.	ASCII
SBS Configuration	48	Data	38	Device Name	S8	-	-	bq20z90	ASCII
SBS Configuration	48	Data	46	Device Chemistry	S5	-	-	LION	ASCII
SBS Configuration	49	Configuration	0	TDA Set %	I1	-1	100	6	%
SBS Configuration	49	Configuration	1	TDA Clear %	I1	-1	100	8	%
SBS Configuration	49	Configuration	2	FD Set %	I1	-1	100	2	%
SBS Configuration	49	Configuration	3	FD Clear %	I1	-1	100	5	%
SBS Configuration	49	Configuration	4	TDA Set Volt Threshold	I2	0	16800	5000	mV
SBS Configuration	49	Configuration	6	TDA Set Volt Time	U1	0	240	5	s
SBS Configuration	49	Configuration	7	TDA Clear Volt	I2	0	16800	5500	mV
SBS Configuration	49	Configuration	9	FD Set Volt Threshold	I2	0	16800	5000	mV
SBS Configuration	49	Configuration	11	FD Volt Time	U1	0	240	5	s
SBS Configuration	49	Configuration	12	FD Clear Volt	I2	0	16800	5500	mV
System Data	56	Manufacturer Data	0	Pack Lot Code	H2	0x0000	0xffff	0x0000	
System Data	56	Manufacturer Data	2	PCB Lot Code	H2	0x0000	0xffff	0x0000	
System Data	56	Manufacturer Data	4	Firmware Version	H2	0x0000	0xffff	0x0000	
System Data	56	Manufacturer Data	6	Hardware Revision	H2	0x0000	0xffff	0x0000	
System Data	56	Manufacturer Data	8	Cell Revision	H2	0x0000	0xffff	0x0000	
System Data	58	Manufacturer Info	0	Manuf. Info	S9	-	-	0123456789 abcdef0123	
System Data	59	Lifetime Data	0	Lifetime Max Temp	I2	0	1400	300	0.1°C
System Data	59	Lifetime Data	2	Lifetime Min Temp	I2	-600	1400	200	0.1°C
System Data	59	Lifetime Data	4	Lifetime Max Cell Voltage	I2	0	32767	3500	mV
System Data	59	Lifetime Data	6	Lifetime Min Cell Voltage	I2	0	32767	3200	mV
System Data	59	Lifetime Data	8	Lifetime Max Pack Voltage	I2	0	32767	14000	mV
System Data	59	Lifetime Data	10	Lifetime Min Pack Voltage	I2	0	32767	12800	mV
System Data	59	Lifetime Data	12	Lifetime Max Chg Current	I2	-32768	32767	1500	mA
System Data	59	Lifetime Data	14	Lifetime Max Dsg Current	I2	-32768	32767	-3000	mA
System Data	59	Lifetime Data	16	Lifetime Max Chg Power	I2	-32768	32767	1500	cWatt
System Data	59	Lifetime Data	18	Lifetime Max Dsg Power	I2	-32768	32767	-1500	cWatt
System Data	59	Lifetime Data	22	Life Max AvgDsg Cur	I2	-32768	32767	-1000	mA
System Data	59	Lifetime Data	26	Life Max AvgDsg Pow	I2	-32768	32767	-1500	cW
System Data	59	Lifetime Data	28	Lifetime Avg Temp	I2	-40	1400	250	0.1°C
System Data	60	Lifetime Temp Samples	0	LT Temp Samples	I4	0	140000000	0	Count
Configuration	64	Registers	0	Operation Cfg A	H2	0x0000	0xffff	0x0f29	
Configuration	64	Registers	2	Operation Cfg B	H2	0x0000	0xffff	0x6440	

**Table 3. DATA FLASH VALUES (continued)**

Class	Subclass ID	Subclass	Offset	Name	Data Type	Min Value	Max Value	Default Value	Units
Configuration	64	Registers	4	Operation Cfg C	H2	0x0000	0xffff	0x0000	
Configuration	64	Registers	6	Permanent Fail Cfg	H2	0x0000	0xffff	0x0000	
Configuration	64	Registers	8	Non-Removable Cfg	H2	0x0000	0xffff	0x0000	
LED Support	67	LED Cfg	0	LED Flash Rate	U2	0	65535	512	500us
LED Support	67	LED Cfg	2	LED Blink Rate	U2	0	65535	1024	500us
LED Support	67	LED Cfg	4	LED Delay	U2	1	65535	100	500us
LED Support	67	LED Cfg	6	LED Hold Time	U1	0	255	4	sec
LED Support	67	LED Cfg	7	CHG Flash Alarm	I1	-1	101	10	%
LED Support	67	LED Cfg	8	CHG Thresh 1	I1	-1	101	0	%
LED Support	67	LED Cfg	9	CHG Thresh 2	I1	-1	101	20	%
LED Support	67	LED Cfg	10	CHG Thresh 3	I1	-1	101	40	%
LED Support	67	LED Cfg	11	CHG Thresh 4	I1	-1	101	60	%
LED Support	67	LED Cfg	12	CHG Thresh 5	I1	-1	101	80	%
LED Support	67	LED Cfg	13	DSG Flash Alarm	I1	-1	101	10	%
LED Support	67	LED Cfg	14	DSG Thresh 1	I1	-1	101	0	%
LED Support	67	LED Cfg	15	DSG Thresh 2	I1	-1	101	20	%
LED Support	67	LED Cfg	16	DSG Thresh 3	I1	-1	101	40	%
LED Support	67	LED Cfg	17	DSG Thresh 4	I1	-1	101	60	%
LED Support	67	LED Cfg	18	DSG Thresh 5	I1	-1	101	80	%
LED Support	67	LED Cfg	19	Sink Current	U1	0	3	3	
Power	68	Power	0	Flash Update OK Voltage	I2	6000	20000	7500	mV
Power	68	Power	2	Shutdown Voltage	I2	5000	20000	7000	mV
Power	68	Power	4	Shutdown Time	U1	0	2440	10	s
Power	68	Power	5	Charger Present	I2	0	23000	3000	mV
Power	68	Power	7	Sleep Current	I2	0	100	10	mA
Power	68	Power	9	Bus Low Time	U1	0	255	5	s
Power	68	Power	10	Cal Inhibit Temp Low	I2	-400	1200	50	0.1°C
Power	68	Power	12	Cal Inhibit Temp High	I2	-400	1200	450	0.1°C
Power	68	Power	14	Sleep Voltage Time	U1	0	240	5	s
Power	68	Power	15	Sleep Current Time	U1	0	255	20	s
Power	68	Power	16	Wake Current Reg	H1	0x00	0x07	0x00	
Gas Gauging	80	IT Cfg	0	Load Select	U1	0	255	3	
Gas Gauging	80	IT Cfg	1	Load Mode	U1	0	255	0	
Gas Gauging	80	IT Cfg	45	Term Voltage	I2	-32768	32767	12000	mV
Gas Gauging	80	IT Cfg	60	User Rate-mA	I2	2000	9000	0	mA
Gas Gauging	80	IT Cfg	62	User Rate-mW	I2	3000	14000	0	10mW
Gas Gauging	80	IT Cfg	64	Reserve Cap-mAh	I2	0	9000	0	mAh
Gas Gauging	80	IT Cfg	66	Reserve Cap-mWh	I2	0	14000	0	10mWh
Gas Gauging	81	Current Thresholds	0	Dsg Current Threshold	I2	0	2000	100	mA
Gas Gauging	81	Current Thresholds	2	Chg Current Threshold	I2	0	2000	50	mA
Gas Gauging	81	Current Thresholds	4	Quit Current	I2	0	1000	10	mA
Gas Gauging	81	Current Thresholds	6	Dsg Relax Time	U1	0	255	1	s
Gas Gauging	81	Current Thresholds	7	Chg Relax Time	U1	0	255	60	s
Gas Gauging	82	State	0	Qmax Cell 0	I2	0	32767	4400	mAh
Gas Gauging	82	State	2	Qmax Cell 1	I2	0	32767	4400	mAh
Gas Gauging	82	State	4	Qmax Cell 2	I2	0	32767	4400	mAh
Gas Gauging	82	State	6	Qmax Cell 3	I2	0	32767	4400	mAh

**Table 3. DATA FLASH VALUES (continued)**

Class	Subclass ID	Subclass	Offset	Name	Data Type	Min Value	Max Value	Default Value	Units
Gas Gauging	82	State	8	Qmax Pack	I2	0	32767	4400	mAh
Gas Gauging	82	State	12	Update Status	H1	0x00	0x03	0x00	
Gas Gauging	82	State	21	Avg I Last Run	I2	-32768	32767	-2000	mA
Gas Gauging	82	State	23	Avg P Last Run	I2	-32768	32767	-3022	cWatt
Gas Gauging	82	State	25	Delta Voltage	I2	-32768	32767	0	mV
Ra Table	88	R_a0	0	Cell0 R_a flag	H2	0x0000	0x0000	0xff55	
Ra Table	88	R_a0	2	Cell0 R_a 0	I2	183	183	160	2 <sup>~</sup> 10Ω
Ra Table	88	R_a0	4	Cell0 R_a 1	I2	181	181	166	2 <sup>~</sup> 10Ω
Ra Table	88	R_a0	6	Cell0 R_a 2	I2	198	198	153	2 <sup>~</sup> 10Ω
Ra Table	88	R_a0	8	Cell0 R_a 3	I2	244	244	151	2 <sup>~</sup> 10Ω
Ra Table	88	R_a0	10	Cell0 R_a 4	I2	254	254	145	2 <sup>~</sup> 10Ω
Ra Table	88	R_a0	12	Cell0 R_a 5	I2	261	261	152	2 <sup>~</sup> 10Ω
Ra Table	88	R_a0	14	Cell0 R_a 6	I2	333	333	176	2 <sup>~</sup> 10Ω
Ra Table	88	R_a0	16	Cell0 R_a 7	I2	338	338	204	2 <sup>~</sup> 10Ω
Ra Table	88	R_a0	18	Cell0 R_a 8	I2	345	345	222	2 <sup>~</sup> 10Ω
Ra Table	88	R_a0	20	Cell0 R_a 9	I2	350	350	254	2 <sup>~</sup> 10Ω
Ra Table	88	R_a0	22	Cell0 R_a 10	I2	382	382	315	2 <sup>~</sup> 10Ω
Ra Table	88	R_a0	24	Cell0 R_a 11	I2	429	429	437	2 <sup>~</sup> 10Ω
Ra Table	88	R_a0	26	Cell0 R_a 12	I2	502	502	651	2 <sup>~</sup> 10Ω
Ra Table	88	R_a0	28	Cell0 R_a 13	I2	545	545	1001	2 <sup>~</sup> 10Ω
Ra Table	88	R_a0	30	Cell0 R_a 14	I2	366	366	1458	2 <sup>~</sup> 10Ω
Ra Table	89	R_a1	0	Cell1 R_a flag	H2	0x0000	0x0000	0xff55	
Ra Table	89	R_a1	2	Cell1 R_a 0	I2	183	183	160	2 <sup>~</sup> 10Ω
Ra Table	89	R_a1	4	Cell1 R_a 1	I2	181	181	166	2 <sup>~</sup> 10Ω
Ra Table	89	R_a1	6	Cell1 R_a 2	I2	198	198	153	2 <sup>~</sup> 10Ω
Ra Table	89	R_a1	8	Cell1 R_a 3	I2	244	244	151	2 <sup>~</sup> 10Ω
Ra Table	89	R_a1	10	Cell1 R_a 4	I2	254	254	145	2 <sup>~</sup> 10Ω
Ra Table	89	R_a1	12	Cell1 R_a 5	I2	261	261	152	2 <sup>~</sup> 10Ω
Ra Table	89	R_a1	14	Cell1 R_a 6	I2	333	333	176	2 <sup>~</sup> 10Ω
Ra Table	89	R_a1	16	Cell1 R_a 7	I2	338	338	204	2 <sup>~</sup> 10Ω
Ra Table	89	R_a1	18	Cell1 R_a 8	I2	345	345	222	2 <sup>~</sup> 10Ω
Ra Table	89	R_a1	20	Cell1 R_a 9	I2	350	350	254	2 <sup>~</sup> 10Ω
Ra Table	89	R_a1	22	Cell1 R_a 10	I2	382	382	315	2 <sup>~</sup> 10Ω
Ra Table	89	R_a1	24	Cell1 R_a 11	I2	429	429	437	2 <sup>~</sup> 10Ω
Ra Table	89	R_a1	26	Cell1 R_a 12	I2	502	502	651	2 <sup>~</sup> 10Ω
Ra Table	89	R_a1	28	Cell1 R_a 13	I2	545	545	1001	2 <sup>~</sup> 10Ω
Ra Table	89	R_a1	30	Cell1 R_a 14	I2	366	366	1458	2 <sup>~</sup> 10Ω
Ra Table	90	R_a2	0	Cell2 R_a flag	H2	0x0000	0x0000	0xff55	
Ra Table	90	R_a2	2	Cell2 R_a 0	I2	183	183	160	2 <sup>~</sup> 10Ω
Ra Table	90	R_a2	4	Cell2 R_a 1	I2	181	181	166	2 <sup>~</sup> 10Ω
Ra Table	90	R_a2	6	Cell2 R_a 2	I2	198	198	153	2 <sup>~</sup> 10Ω
Ra Table	90	R_a2	8	Cell2 R_a 3	I2	244	244	151	2 <sup>~</sup> 10Ω
Ra Table	90	R_a2	10	Cell2 R_a 4	I2	254	254	145	2 <sup>~</sup> 10Ω
Ra Table	90	R_a2	12	Cell2 R_a 5	I2	261	261	152	2 <sup>~</sup> 10Ω
Ra Table	90	R_a2	14	Cell2 R_a 6	I2	333	333	176	2 <sup>~</sup> 10Ω
Ra Table	90	R_a2	16	Cell2 R_a 7	I2	338	338	204	2 <sup>~</sup> 10Ω
Ra Table	90	R_a2	18	Cell2 R_a 8	I2	345	345	222	2 <sup>~</sup> 10Ω
Ra Table	90	R_a2	20	Cell2 R_a 9	I2	350	350	254	2 <sup>~</sup> 10Ω
Ra Table	90	R_a2	22	Cell2 R_a 10	I2	382	382	315	2 <sup>~</sup> 10Ω
Ra Table	90	R_a2	24	Cell2 R_a 11	I2	429	429	437	2 <sup>~</sup> 10Ω

**Table 3. DATA FLASH VALUES (continued)**

Class	Subclass ID	Subclass	Offset	Name	Data Type	Min Value	Max Value	Default Value	Units
Ra Table	90	R_a2	26	Cell2 R_a 12	I2	502	502	651	2 <sup>~</sup> 10Ω
Ra Table	90	R_a2	28	Cell2 R_a 13	I2	545	545	1001	2 <sup>~</sup> 10Ω
Ra Table	90	R_a2	30	Cell2 R_a 14	I2	366	366	1458	2 <sup>~</sup> 10Ω
Ra Table	91	R_a3	0	Cell3 R_a flag	H2	0x0	0x0	0xff55	
Ra Table	91	R_a3	2	Cell3 R_a 0	I2	183	183	160	2 <sup>~</sup> 10Ω
Ra Table	91	R_a3	4	Cell3 R_a 1	I2	181	181	166	2 <sup>~</sup> 10Ω
Ra Table	91	R_a3	6	Cell3 R_a 2	I2	198	198	153	2 <sup>~</sup> 10Ω
Ra Table	91	R_a3	8	Cell3 R_a 3	I2	244	244	151	2 <sup>~</sup> 10Ω
Ra Table	91	R_a3	10	Cell3 R_a 4	I2	254	254	145	2 <sup>~</sup> 10Ω
Ra Table	91	R_a3	12	Cell3 R_a 5	I2	261	261	152	2 <sup>~</sup> 10Ω
Ra Table	91	R_a3	14	Cell3 R_a 6	I2	333	333	176	2 <sup>~</sup> 10Ω
Ra Table	91	R_a3	16	Cell3 R_a 7	I2	338	338	204	2 <sup>~</sup> 10Ω
Ra Table	91	R_a3	18	Cell3 R_a 8	I2	345	345	222	2 <sup>~</sup> 10Ω
Ra Table	91	R_a3	20	Cell3 R_a 9	I2	350	350	254	2 <sup>~</sup> 10Ω
Ra Table	91	R_a3	22	Cell3 R_a 10	I2	382	382	315	2 <sup>~</sup> 10Ω
Ra Table	91	R_a3	24	Cell3 R_a 11	I2	429	429	437	2 <sup>~</sup> 10Ω
Ra Table	91	R_a3	26	Cell3 R_a 12	I2	502	502	651	2 <sup>~</sup> 10Ω
Ra Table	91	R_a3	28	Cell3 R_a 13	I2	545	545	1001	2 <sup>~</sup> 10Ω
Ra Table	91	R_a3	30	Cell3 R_a 14	I2	366	366	1458	2 <sup>~</sup> 10Ω
Ra Table	92	R_a0x	0	xCell0 R_a flag	H2	0xffff	0xffff	0xffff	
Ra Table	92	R_a0x	2	xCell0 R_a 0	I2	183	183	160	2 <sup>~</sup> 10Ω
Ra Table	92	R_a0x	4	xCell0 R_a 1	I2	181	181	166	2 <sup>~</sup> 10Ω
Ra Table	92	R_a0x	6	xCell0 R_a 2	I2	198	198	153	2 <sup>~</sup> 10Ω
Ra Table	92	R_a0x	8	xCell0 R_a 3	I2	244	244	151	2 <sup>~</sup> 10Ω
Ra Table	92	R_a0x	10	xCell0 R_a 4	I2	254	254	145	2 <sup>~</sup> 10Ω
Ra Table	92	R_a0x	12	xCell0 R_a 5	I2	261	261	152	2 <sup>~</sup> 10Ω
Ra Table	92	R_a0x	14	xCell0 R_a 6	I2	333	333	176	2 <sup>~</sup> 10Ω
Ra Table	92	R_a0x	16	xCell0 R_a 7	I2	338	338	204	2 <sup>~</sup> 10Ω
Ra Table	92	R_a0x	18	xCell0 R_a 8	I2	345	345	222	2 <sup>~</sup> 10Ω
Ra Table	92	R_a0x	20	xCell0 R_a 9	I2	350	350	254	2 <sup>~</sup> 10Ω
Ra Table	92	R_a0x	22	xCell0 R_a 10	I2	382	382	315	2 <sup>~</sup> 10Ω
Ra Table	92	R_a0x	24	xCell0 R_a 11	I2	429	429	437	2 <sup>~</sup> 10Ω
Ra Table	92	R_a0x	26	xCell0 R_a 12	I2	502	502	651	2 <sup>~</sup> 10Ω
Ra Table	92	R_a0x	28	xCell0 R_a 13	I2	545	545	1001	2 <sup>~</sup> 10Ω
Ra Table	92	R_a0x	30	xCell0 R_a 14	I2	366	366	1458	2 <sup>~</sup> 10Ω
Ra Table	93	R_a1x	0	xCell1 R_a flag	H2	0xffff	0xffff	0xffff	
Ra Table	93	R_a1x	2	xCell1 R_a 0	I2	183	183	160	2 <sup>~</sup> 10Ω
Ra Table	93	R_a1x	4	xCell1 R_a 1	I2	181	181	166	2 <sup>~</sup> 10Ω
Ra Table	93	R_a1x	6	xCell1 R_a 2	I2	198	198	153	2 <sup>~</sup> 10Ω
Ra Table	93	R_a1x	8	xCell1 R_a 3	I2	244	244	151	2 <sup>~</sup> 10Ω
Ra Table	93	R_a1x	10	xCell1 R_a 4	I2	254	254	145	2 <sup>~</sup> 10Ω
Ra Table	93	R_a1x	12	xCell1 R_a 5	I2	261	261	152	2 <sup>~</sup> 10Ω
Ra Table	93	R_a1x	14	xCell1 R_a 6	I2	333	333	176	2 <sup>~</sup> 10Ω
Ra Table	93	R_a1x	16	xCell1 R_a 7	I2	338	338	204	2 <sup>~</sup> 10Ω
Ra Table	93	R_a1x	18	xCell1 R_a 8	I2	345	345	222	2 <sup>~</sup> 10Ω
Ra Table	93	R_a1x	20	xCell1 R_a 9	I2	350	350	254	2 <sup>~</sup> 10Ω
Ra Table	93	R_a1x	22	xCell1 R_a 10	I2	382	382	315	2 <sup>~</sup> 10Ω
Ra Table	93	R_a1x	24	xCell1 R_a 11	I2	429	429	437	2 <sup>~</sup> 10Ω
Ra Table	93	R_a1x	26	xCell1 R_a 12	I2	502	502	651	2 <sup>~</sup> 10Ω
Ra Table	93	R_a1x	28	xCell1 R_a 13	I2	545	545	1001	2 <sup>~</sup> 10Ω

**Table 3. DATA FLASH VALUES (continued)**

Class	Subclass ID	Subclass	Offset	Name	Data Type	Min Value	Max Value	Default Value	Units
Ra Table	93	R_a1x	30	xCell1 R_a 14	I2	366	366	1458	2 <sup>~</sup> 10Ω
Ra Table	94	R_a2x	0	xCell2 R_a flag	H2	0xffff	0xffff	0xffff	
Ra Table	94	R_a2x	2	xCell2 R_a 0	I2	183	183	160	2 <sup>~</sup> 10Ω
Ra Table	94	R_a2x	4	xCell2 R_a 1	I2	181	181	166	2 <sup>~</sup> 10Ω
Ra Table	94	R_a2x	6	xCell2 R_a 2	I2	198	198	153	2 <sup>~</sup> 10Ω
Ra Table	94	R_a2x	8	xCell2 R_a 3	I2	244	244	151	2 <sup>~</sup> 10Ω
Ra Table	94	R_a2x	10	xCell2 R_a 4	I2	254	254	145	2 <sup>~</sup> 10Ω
Ra Table	94	R_a2x	12	xCell2 R_a 5	I2	261	261	152	2 <sup>~</sup> 10Ω
Ra Table	94	R_a2x	14	xCell2 R_a 6	I2	333	333	176	2 <sup>~</sup> 10Ω
Ra Table	94	R_a2x	16	xCell2 R_a 7	I2	338	338	204	2 <sup>~</sup> 10Ω
Ra Table	94	R_a2x	18	xCell2 R_a 8	I2	345	345	222	2 <sup>~</sup> 10Ω
Ra Table	94	R_a2x	20	xCell2 R_a 9	I2	350	350	254	2 <sup>~</sup> 10Ω
Ra Table	94	R_a2x	22	xCell2 R_a 10	I2	382	382	315	2 <sup>~</sup> 10Ω
Ra Table	94	R_a2x	24	xCell2 R_a 11	I2	429	429	437	2 <sup>~</sup> 10Ω
Ra Table	94	R_a2x	26	xCell2 R_a 12	I2	502	502	651	2 <sup>~</sup> 10Ω
Ra Table	94	R_a2x	28	xCell2 R_a 13	I2	545	545	1001	2 <sup>~</sup> 10Ω
Ra Table	94	R_a2x	30	xCell2 R_a 14	I2	366	366	1458	2 <sup>~</sup> 10Ω
Ra Table	95	R_a3x	0	xCell3 R_a flag	H2	0xffff	0xffff	0xffff	
Ra Table	95	R_a3x	2	xCell3 R_a 0	I2	183	183	160	2 <sup>~</sup> 10Ω
Ra Table	95	R_a3x	4	xCell3 R_a 1	I2	181	181	166	2 <sup>~</sup> 10Ω
Ra Table	95	R_a3x	6	xCell3 R_a 2	I2	198	198	153	2 <sup>~</sup> 10Ω
Ra Table	95	R_a3x	8	xCell3 R_a 3	I2	244	244	151	2 <sup>~</sup> 10Ω
Ra Table	95	R_a3x	10	xCell3 R_a 4	I2	254	254	145	2 <sup>~</sup> 10Ω
Ra Table	95	R_a3x	12	xCell3 R_a 5	I2	261	261	152	2 <sup>~</sup> 10Ω
Ra Table	95	R_a3x	14	xCell3 R_a 6	I2	333	333	176	2 <sup>~</sup> 10Ω
Ra Table	95	R_a3x	16	xCell3 R_a 7	I2	338	338	204	2 <sup>~</sup> 10Ω
Ra Table	95	R_a3x	18	xCell3 R_a 8	I2	345	345	222	2 <sup>~</sup> 10Ω
Ra Table	95	R_a3x	20	xCell3 R_a 9	I2	350	350	254	2 <sup>~</sup> 10Ω
Ra Table	95	R_a3x	22	xCell3 R_a 10	I2	382	382	315	2 <sup>~</sup> 10Ω
Ra Table	95	R_a3x	24	xCell3 R_a 11	I2	429	429	437	2 <sup>~</sup> 10Ω
Ra Table	95	R_a3x	26	xCell3 R_a 12	I2	502	502	651	2 <sup>~</sup> 10Ω
Ra Table	95	R_a3x	28	xCell3 R_a 13	I2	545	545	1001	2 <sup>~</sup> 10Ω
Ra Table	95	R_a3x	30	xCell3 R_a 14	I2	366	366	1458	2 <sup>~</sup> 10Ω
PF Status	96	Device Status Data	0	PF Flags 1	H2	0x0000	0x6fff	0x0000	
PF Status	96	Device Status Data	2	Fuse Flag	H2	0x0000	0xffff	0x0000	
PF Status	96	Device Status Data	4	PF Voltage	I2	0	32767	0	mV
PF Status	96	Device Status Data	6	PF C4 Voltage	I2	0	9999	0	mV
PF Status	96	Device Status Data	8	PF C3 Voltage	I2	0	9999	0	mV
PF Status	96	Device Status Data	10	PF C2 Voltage	I2	0	9999	0	mV
PF Status	96	Device Status Data	12	PF C1 Voltage	I2	0	9999	0	mV
PF Status	96	Device Status Data	14	PF Current	I2	-32768	32767	0	mA
PF Status	96	Device Status Data	16	PF Temperature	I2	-9999	9999	0	0.1 K
PF Status	96	Device Status Data	18	PF Batt Stat	H2	0x0000	0xffff	0x0000	

**Table 3. DATA FLASH VALUES (continued)**

Class	Subclass ID	Subclass	Offset	Name	Data Type	Min Value	Max Value	Default Value	Units
PF Status	96	Device Status Data	20	PF RC-mAh	I2	0	32767	0	mAh
PF Status	96	Device Status Data	22	PF RC-10mWh	I2	0	32767	0	cWattHr
PF Status	96	Device Status Data	24	PF Chg Status	H2	0x0000	0xffff	0x0000	
PF Status	96	Device Status Data	26	PF Safety Status	H2	0x0000	0xffff	0x0000	
PF Status	96	Device Status Data	28	PF Flags 2	H2	0x0000	0x8000	0x0000	
PF Status	97	AFE Regs	0	AFE Status	H1	0x00	0xff	0x00	
PF Status	97	AFE Regs	1	AFE Output	H1	0x00	0xff	0x00	
PF Status	97	AFE Regs	2	AFE State	H1	0x00	0xff	0x00	
PF Status	97	AFE Regs	3	AFE Function	H1	0x00	0xff	0x00	
PF Status	97	AFE Regs	4	AFE Cell Select	H1	0x00	0xff	0x00	
PF Status	97	AFE Regs	5	AFE OLV	H1	0x00	0xff	0x00	
PF Status	97	AFE Regs	6	AFE OLT	H1	0x00	0xff	0x00	
PF Status	97	AFE Regs	7	AFE SCC	H1	0x00	0xff	0x00	
PF Status	97	AFE Regs	8	AFE SCD	H1	0x00	0xff	0x00	
Calibration	104	Data	0	CC Gain	F4	0.1	4	0.9419	
Calibration	104	Data	4	CC Delta	F4	29826	1193046	280932.6	
Calibration	104	Data	8	Ref Voltage	I2	0	32767	24500	50μV
Calibration	104	Data	12	AFE Pack Gain	I2	0	32767	22050	μV/cnt
Calibration	104	Data	14	CC Offset	I2	-32768	32767	-1667	
Calibration	104	Data	16	Board Offset	I2	-32767	32767	0	
Calibration	104	Data	18	Int Temp Offset	I1	-128	127	0	
Calibration	104	Data	19	Ext1 Temp Offset	I1	-128	127	0	
Calibration	104	Data	20	Ext2 Temp Offset	I1	-128	127	0	
Calibration	105	Config	0	CC Current	I2	0	32767	3000	mA
Calibration	105	Config	2	Voltage Signal	I2	0	32767	16800	mV
Calibration	105	Config	4	Temp Signal	I2	0	32767	2980	0.1°C
Calibration	105	Config	6	CC Offset Time	U2	0	65535	250	ms
Calibration	105	Config	8	ADC Offset Time	U2	0	65535	32	ms
Calibration	105	Config	10	CC Gain Time	U2	0	65535	250	ms
Calibration	105	Config	12	Voltage Time	U2	0	65535	1984	ms
Calibration	105	Config	14	Temperature Time	U2	0	65535	32	s
Calibration	105	Config	17	Cal Mode Timeout	U2	0	65535	38400	1/128 s
Calibration	106	Temp Model	0	Ext Coef 1	I2	-32768	32767	-28285	s
Calibration	106	Temp Model	2	Ext Coef 2	I2	-32768	32767	20848	s
Calibration	106	Temp Model	4	Ext Coef 3	I2	-32768	32767	-7537	s
Calibration	106	Temp Model	6	Ext Coef 4	I2	-32768	32767	4012	s
Calibration	106	Temp Model	8	Ext Min AD	I2	-32768	32767	0	s
Calibration	106	Temp Model	10	Ext Max Temp	I2	-32768	32767	4012	s
Calibration	106	Temp Model	12	Int Coef 1	I2	-32768	32767	0	s
Calibration	106	Temp Model	14	Int Coef 2	I2	-32768	32767	0	s
Calibration	106	Temp Model	16	Int Coef 3	I2	-32768	32767	-11136	s
Calibration	106	Temp Model	18	Int Coef 4	I2	-32768	32767	5754	s
Calibration	106	Temp Model	20	Int Min AD	I2	-32768	32767	0	s
Calibration	106	Temp Model	22	Int Max Temp	I2	-32768	32767	5754	s
Calibration	107	Current	0	Filter	U1	0	255	239	
Calibration	107	Current	1	Deadband	U1	0	255	3	mA
Calibration	107	Current	2	CC Deadband	U1	0	255	34	294 nV



**PACKAGING INFORMATION**

Orderable Device	Status (1)	Package Type	Package Drawing	Pins	Package Qty	Eco Plan (2)	Lead/Ball Finish (6)	MSL Peak Temp (3)	Op Temp (°C)	Device Marking (4/5)	Samples
BQ20Z90DBTR-V110	NRND	TSSOP	DBT	30	2000	Green (RoHS & no Sb/Br)	CU NIPDAU	Level-2-260C-1 YEAR	-40 to 125	BQ20Z90DBT	
BQ20Z90DBTR-V110G4	NRND	TSSOP	DBT	30	2000	Green (RoHS & no Sb/Br)	CU NIPDAU	Level-2-260C-1 YEAR	-40 to 125	BQ20Z90DBT	

(1) The marketing status values are defined as follows:

**ACTIVE:** Product device recommended for new designs.

**LIFEBUY:** TI has announced that the device will be discontinued, and a lifetime-buy period is in effect.

**NRND:** Not recommended for new designs. Device is in production to support existing customers, but TI does not recommend using this part in a new design.

**PREVIEW:** Device has been announced but is not in production. Samples may or may not be available.

**OBSOLETE:** TI has discontinued the production of the device.

(2) **RoHS:** TI defines "RoHS" to mean semiconductor products that are compliant with the current EU RoHS requirements for all 10 RoHS substances, including the requirement that RoHS substance do not exceed 0.1% by weight in homogeneous materials. Where designed to be soldered at high temperatures, "RoHS" products are suitable for use in specified lead-free processes. TI may reference these types of products as "Pb-Free".

**RoHS Exempt:** TI defines "RoHS Exempt" to mean products that contain lead but are compliant with EU RoHS pursuant to a specific EU RoHS exemption.

**Green:** TI defines "Green" to mean the content of Chlorine (Cl) and Bromine (Br) based flame retardants meet JS709B low halogen requirements of <=1000ppm threshold. Antimony trioxide based flame retardants must also meet the <=1000ppm threshold requirement.

(3) MSL, Peak Temp. - The Moisture Sensitivity Level rating according to the JEDEC industry standard classifications, and peak solder temperature.

(4) There may be additional marking, which relates to the logo, the lot trace code information, or the environmental category on the device.

(5) Multiple Device Markings will be inside parentheses. Only one Device Marking contained in parentheses and separated by a "~" will appear on a device. If a line is indented then it is a continuation of the previous line and the two combined represent the entire Device Marking for that device.

(6) Lead/Ball Finish - Orderable Devices may have multiple material finish options. Finish options are separated by a vertical ruled line. Lead/Ball Finish values may wrap to two lines if the finish value exceeds the maximum column width.

**Important Information and Disclaimer:**The information provided on this page represents TI's knowledge and belief as of the date that it is provided. TI bases its knowledge and belief on information provided by third parties, and makes no representation or warranty as to the accuracy of such information. Efforts are underway to better integrate information from third parties. TI has taken and continues to take reasonable steps to provide representative and accurate information but may not have conducted destructive testing or chemical analysis on incoming materials and chemicals. TI and TI suppliers consider certain information to be proprietary, and thus CAS numbers and other limited information may not be available for release.

In no event shall TI's liability arising out of such information exceed the total purchase price of the TI part(s) at issue in this document sold by TI to Customer on an annual basis.



**TAPE AND REEL INFORMATION**

**QUADRANT ASSIGNMENTS FOR PIN 1 ORIENTATION IN TAPE**

\*All dimensions are nominal

Device	Package Type	Package Drawing	Pins	SPQ	Reel Diameter (mm)	Reel Width W1 (mm)	A0 (mm)	B0 (mm)	K0 (mm)	P1 (mm)	W (mm)	Pin1 Quadrant
BQ20Z90DBTR-V110	TSSOP	DBT	30	2000	330.0	16.4	6.95	8.3	1.6	8.0	16.0	Q1

**TAPE AND REEL BOX DIMENSIONS**



\*All dimensions are nominal

Device	Package Type	Package Drawing	Pins	SPQ	Length (mm)	Width (mm)	Height (mm)
BQ20Z90DBTR-V110	TSSOP	DBT	30	2000	367.0	367.0	38.0

DBT (R-PDSO-G30)

PLASTIC SMALL OUTLINE

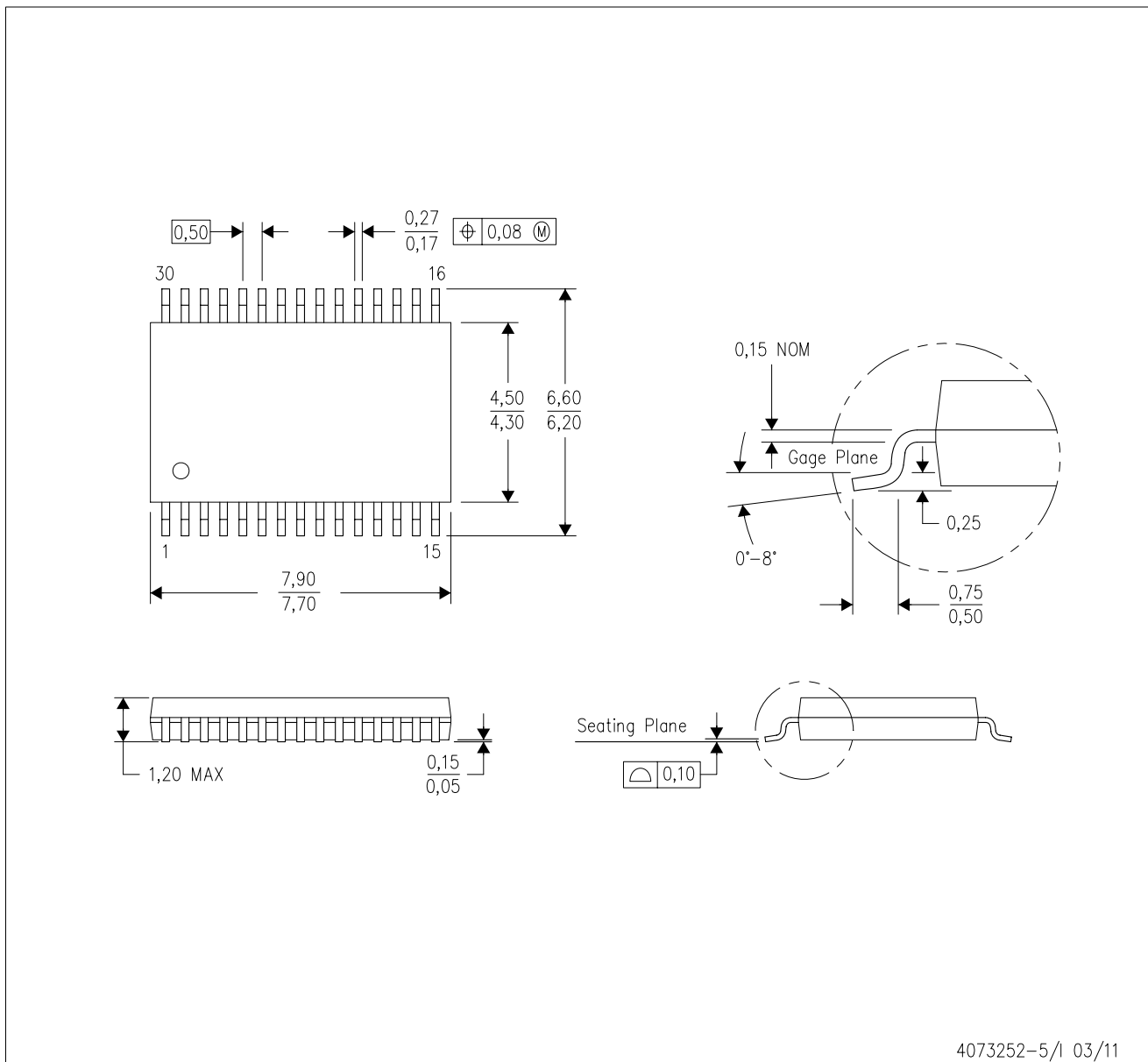

- NOTES:
- A. All linear dimensions are in millimeters. Dimensioning and tolerancing per ASME Y14.5M-1994.
  - B. This drawing is subject to change without notice.
  - C. Body dimensions do not include mold flash or protrusion.
  - D. Falls within JEDEC MO-153.

## IMPORTANT NOTICE AND DISCLAIMER

TI PROVIDES TECHNICAL AND RELIABILITY DATA (INCLUDING DATASHEETS), DESIGN RESOURCES (INCLUDING REFERENCE DESIGNS), APPLICATION OR OTHER DESIGN ADVICE, WEB TOOLS, SAFETY INFORMATION, AND OTHER RESOURCES "AS IS" AND WITH ALL FAULTS, AND DISCLAIMS ALL WARRANTIES, EXPRESS AND IMPLIED, INCLUDING WITHOUT LIMITATION ANY IMPLIED WARRANTIES OF MERCHANTABILITY, FITNESS FOR A PARTICULAR PURPOSE OR NON-INFRINGEMENT OF THIRD PARTY INTELLECTUAL PROPERTY RIGHTS.

These resources are intended for skilled developers designing with TI products. You are solely responsible for (1) selecting the appropriate TI products for your application, (2) designing, validating and testing your application, and (3) ensuring your application meets applicable standards, and any other safety, security, or other requirements. These resources are subject to change without notice. TI grants you permission to use these resources only for development of an application that uses the TI products described in the resource. Other reproduction and display of these resources is prohibited. No license is granted to any other TI intellectual property right or to any third party intellectual property right. TI disclaims responsibility for, and you will fully indemnify TI and its representatives against, any claims, damages, costs, losses, and liabilities arising out of your use of these resources.

TI's products are provided subject to TI's Terms of Sale ([www.ti.com/legal/termsofsale.html](http://www.ti.com/legal/termsofsale.html)) or other applicable terms available either on [ti.com](http://ti.com) or provided in conjunction with such TI products. TI's provision of these resources does not expand or otherwise alter TI's applicable warranties or warranty disclaimers for TI products.

Mailing Address: Texas Instruments, Post Office Box 655303, Dallas, Texas 75265  
Copyright © 2018, Texas Instruments Incorporated

## Looking for pricing, stock, or lifecycle information?

Click below to explore more details on WIN SOURCE:

 [View BQ20Z90DBTR-V110](#) on WIN SOURCE

 [Texas Instruments](#) Information

## Optimize Your Supply Chain with WIN SOURCE Solutions

-  Global Sourcing Solution
-  Obsolete Management
-  Cost Control Management
-  Shortage Management
-  Alternative Solution
-  Excess Inventory Management