



**THE DATASHEET OF
BQ20Z80ADBTV110**



SBS 1.1-COMPLIANT GAS GAUGE ENABLED WITH IMPEDANCE TRACK™ TECHNOLOGY FOR USE WITH THE bq29312A

FEATURES

- Patented Impedance Track™ Technology Accurately Measures Available Charge in Li-Ion and Li-Polymer Batteries
- Better than 1% Error Over Lifetime of the Battery
- Instant Accuracy – No Learning Cycle Required
- Supports the Smart Battery Specification SBS V1.1
- Works With the TI bq29312A Analog Front-End (AFE) Protection IC to Provide Complete Pack Electronics Solution
- Full Array of Programmable Voltage, Current, and Temperature Protection Features
- Integrated Time Base Removes Need for External Crystal with Optional Crystal Input
- Electronics for 7.2-V, 10.8-V or 14.4-V Battery Packs With Few External Components
- Based on a Powerful Low-Power RISC CPU Core With High-Performance Peripherals
- Integrated Field Programmable FLASH Memory Eliminates the Need for External Configuration Memory
- Measures Charge Flow Using a High-Resolution, 16-Bit Integrating Delta-Sigma Converter
 - Better Than 0.65 nVh of Resolution
 - Self-Calibrating
 - Offset Error Less Than 1 μ V
- Uses 16-Bit Delta-Sigma Converter for Accurate Voltage and Temperature Measurements
- Extensive Data Reporting Options For Improved System Interaction
- Optional Pulse Charging Feature for Improved Charge Times
- Drives 3-, 4- or 5-Segment LED Display for Remaining Capacity Indication
- Supports SHA-1 Authentication
- Lifetime Data Logging

- 38-Pin TSSOP (DBT)

APPLICATIONS

- Notebook PCs
- Medical and Test Equipment
- Portable Instrumentation

DESCRIPTION

The bq20z80 SBS-compliant gas gauge IC, incorporating patented Impedance Track™ technology, is designed for battery-pack or in-system installation. The bq20z80 measures and maintains an accurate record of available charge in Li-ion or Li-polymer batteries using its integrated high-performance analog peripherals. The bq20z80 monitors capacity change, battery impedance, open-circuit voltage, and other critical parameters of the battery pack, and reports the information to the system host controller over a serial-communication bus. It is designed to work with the bq29312A analog front-end (AFE) protection IC to maximize functionality and safety, and minimize component count and cost in smart battery circuits.

The Impedance Track technology continuously analyzes the battery impedance, resulting in superior gas-gauging accuracy. This enables remaining capacity to be calculated with discharge rate, temperature, and cell aging all accounted for during each stage of every cycle.

AVAILABLE OPTIONS

T _A	PACKAGE ⁽¹⁾	
	38-PIN TSSOP (DBT) Tube	38-PIN TSSOP (DBT) Tape and Reel
–40°C to 85°C	bq20z80ADBT ⁽²⁾	bq20z80ADBTR ⁽³⁾
–40°C to 85°C	bq20z80DBT ⁽²⁾	bq20z80DBTR ⁽³⁾

(1) For the most current package and ordering information, see the Package Option Addendum at the end of this document, or see the TI website at www.ti.com.

(2) A single tube quantity is 50 units.

(3) A single reel quantity is 2000 units



Please be aware that an important notice concerning availability, standard warranty, and use in critical applications of Texas Instruments semiconductor products and disclaimers thereto appears at the end of this data sheet.

Impedance Track is a trademark of Texas Instruments.



These devices have limited built-in ESD protection. The leads should be shorted together or the device placed in conductive foam during storage or handling to prevent electrostatic damage to the MOS gates.

SYSTEM DIAGRAM

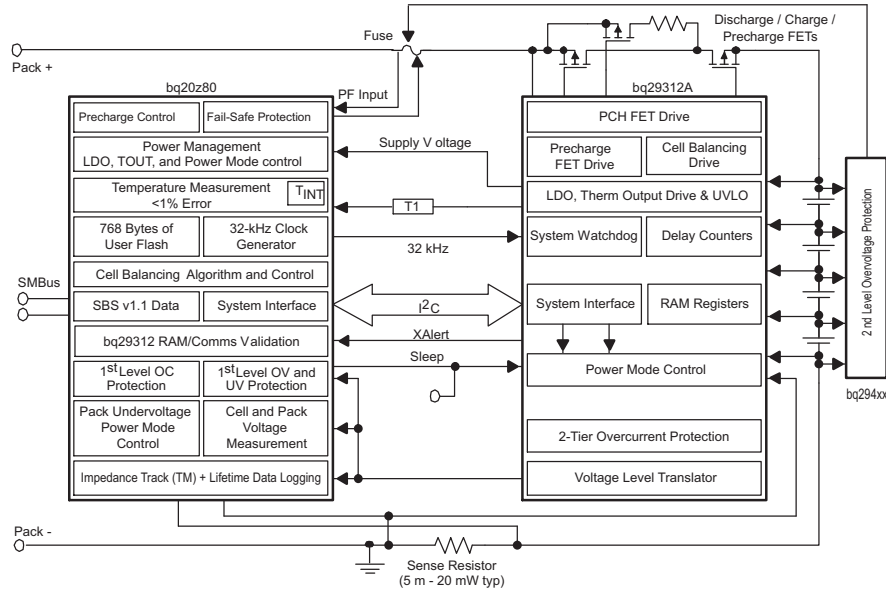

TSSOP (DBT) (TOP VIEW)

VIN	1	38	VSSD
TS1	2	37	NC
TS2	3	36	NC
PU	4	35	CLKOUT
PRES	5	34	XCK1 / VSSA
SCLK	6	33	XCK2 / ROSC
SAFE	7	32	FILT
VDDD	8	31	VDDA
RBI	9	30	VSSA
SDATA	10	29	VSSA
VSSD	11	28	SR1
SAFE	12	27	SR2
NC	13	26	MRST
NC	14	25	XALERT
SMBC	15	24	LED1
SMBD	16	23	LED2
DISP	17	22	LED3
PFIN	18	21	LED4
VSSD	19	20	LED5

NC - No internal connection

TERMINAL FUNCTIONS

TERMINAL		I/O ⁽¹⁾	DESCRIPTION
NO.	NAME		
1	VIN	I	Voltage measurement input from the AFE
2	TS1	I	1 st Thermistor voltage input connection to monitor temperature
3	TS2	I	2 nd Thermistor voltage input connection to monitor temperature
4	PU	O	Output to pull up the $\overline{\text{PRES}}$ pin for system detection
5	$\overline{\text{PRES}}$	I	Active low input to sense system insertion and typically requires additional ESD protection
6	SCLK	I/OD	Communication clock to the AFE
7	SAFE	O	Active high output to enforce additional level of safety protection; e.g., fuse blow. (Inverse of pin 12)
8	VDDD	P	Positive supply for digital circuitry and I/O pins
9	RBI	P	Backup power to the bq20z80 data registers during periods of low operating voltage. RBI accepts a storage capacitor or a battery input.
10	SDATA	I/O	Data transfer to and from the AFE
12	$\overline{\text{SAFE}}$	O	Active low output to enforce additional level of safety protection; e.g., fuse blow. (Inverse of pin 7)
13	NC	–	Not used— leave floating
14	NC	–	Not used— leave floating
15	SMBC	I/OD	SMBus clock open-drain bidirectional pin used to clock the data transfer to and from the bq20z80
16	SMBD	I/OD	SMBus data open-drain bidirectional pin used to transfer address and data to and from the bq20z80
17	$\overline{\text{DISP}}$	I	Display control for the LEDs. This pin is typically connected to bq29312A REG via a 100-k Ω resistor and a push-button switch to VSSD.
18	$\overline{\text{PFIN}}$	I	Active low input to detect secondary protector output status and allows the bq20z80 to report the status of the 2 nd level protection output
20	LED5	O	LED5 display segment that drives an external LED depending on the firmware configuration
21	LED4	O	LED4 display segment that drives an external LED depending on the firmware configuration
22	LED3	O	LED3 display segment that drives an external LED depending on the firmware configuration
23	LED2	O	LED2 display segment that drives an external LED depending on the firmware configuration
24	LED1	O	LED1 display segment that drives an external LED depending on the firmware configuration
25	XALERT	I	Input from bq29312A XALERT output.
26	MRST	I	Master reset input that forces the device into reset when held high
27	SR2	IA	Connections for a small-value sense resistor to monitor the battery charge- and discharge-current flow
28	SR1	IA	Connections for a small-value sense resistor to monitor the battery charge- and discharge-current flow
31	VDDA	P	Positive supply for analog circuitry
32	FILT	IA	Analog input connected to the external PLL filter components which are a 150-pF capacitor to V_{SSA} , in parallel with a 61.9-k Ω resistor and a 2200-pF capacitor in series. Place these components as close as possible to the bq20z80 to ensure optimal performance.
33	XCK2/ROSC	O	32.768-kHz crystal oscillator output pin or connected to a 100-k Ω , 50-ppm or better resistor if the internal oscillator is used.
34	XCK1/VSSA	I	32.768-kHz crystal oscillator input pin or connected to VSSA if the internal oscillator is used
35	CLKOUT	O	32.768-kHz output for the bq29312. This pin should be directly connected to the AFE.
36, 37	NC	-	Not used— leave floating
11, 19, 38	VSSD	P	Negative supply for digital circuitry
29, 30	VSSA	P	Negative supply for analog circuitry.

(1) I = Input, IA = Analog input, I/O = Input/output, I/OD = Input/Open-drain output, O = Output, OA = Analog output, P = Power

ABSOLUTE MAXIMUM RATINGS

over operating free-air temperature range (unless otherwise noted)⁽¹⁾

		RANGE
V_{DDA} and V_{DD} relative to V_{SS} ⁽²⁾	Supply voltage range	–0.3 V to 4.1 V
$V_{(IOD)}$ relative to V_{SS} ⁽²⁾	Open-drain I/O pins	–0.3 V to 6 V
V_I relative to V_{SS} ⁽²⁾	Input voltage range to all other pins	–0.3 V to $V_{DDA} + 0.3$ V
T_A	Operating free-air temperature range	–40°C to 85°C
T_{stg}	Storage temperature range	–65°C to 150°C

(1) Stresses beyond those listed under absolute maximum ratings may cause permanent damage to the device. These are stress ratings only, and functional operation of the device at these or any other conditions beyond those indicated under recommended operating conditions is not implied. Exposure to absolute-maximum-rated conditions for extended periods may affect device reliability.

(2) V_{SS} refers to the common node of $V_{(SSA)}$ and $V_{(SSD)}$.

ELECTRICAL CHARACTERISTICS

$V_{DD} = 3$ V to 3.6 V, $T_A = -40$ °C to 85°C (unless otherwise noted)

PARAMETER		TEST CONDITIONS	MIN	TYP	MAX	UNIT
V_{DD}	Supply voltage	VDDA and VDDD	3	3.3	3.6	V
I_{DD}	Operating mode current	No flash programming		350 ⁽¹⁾		μA
		bq20z80 + bq29312A		375		
$I_{(SLP)}$	Low-power storage mode current	Sleep mode		8 ⁽¹⁾		μA
		bq20z80 + bq29312A		28		
$I_{(SLP)}$	Shutdown Current	Shutdown Mode		0.1 ⁽¹⁾		μA
		bq20z80 + bq29312A		0.1		
V_{OL}	Output voltage low SMBC, SMBD, SDATA, SCLK, \overline{SAFE} , SAFE, PU	$I_{OL} = 0.5$ mA			0.4	V
	LED1 – LED5	$I_{OL} = 10$ mA			0.4	V
V_{OH}	Output high voltage, SMBC, SMBD, SDATA, SCLK, \overline{SAFE} , SAFE, PU	$I_{OH} = -1$ mA	$V_{DD} - 0.5$			V
V_{IL}	Input voltage low SMBC, SMBD, SDATA, SCLK, XALERT, PRES, PFIN		–0.3		0.8	V
	DISP		–0.3		0.8	V
V_{IH}	Input voltage high SMBC, SMBD, SDATA, SCLK, XALERT, PRES, PFIN		2		6	V
	DISP		2		$V_{DD} + 0.3$	V
C_{IN}	Input capacitance			5		pF
$V_{(AI1)}$	Input voltage range VIN, TS1, TS2		$V_{SS} - 0.3$		$0.8 \times V_{DD}$	V
$V_{(AI2)}$	Input voltage range SR1, SR2		$V_{SS} - 0.25$		0.25	
$Z_{(AI1)}$	Input impedance SR1, SR2	0 V–1 V	2.5			MΩ
$Z_{(AI2)}$	Input impedance VIN, TS1, TS2	0 V–1 V	8			MΩ

(1) This value does not include the bq29312A

POWER-ON RESET

$V_{DD} = 3\text{ V to }3.6\text{ V}$, $T_A = -40^\circ\text{C to }85^\circ\text{C}$ (unless otherwise noted)

PARAMETER	TEST CONDITIONS	MIN	TYP	MAX	UNIT
V_{IT-} Negative-going voltage input		2.1	2.3	2.5	V
V_{HYS} Power-on reset hysteresis		50	150	200	mV

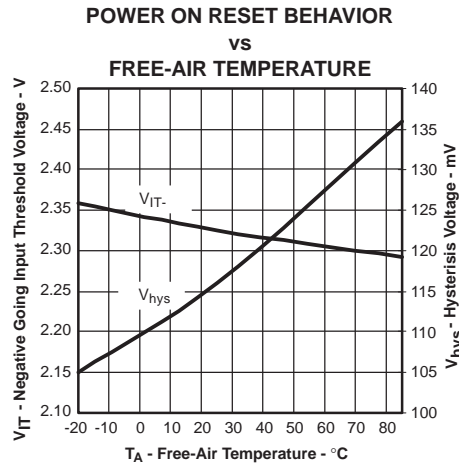

INTEGRATING ADC (Coulomb Counter) CHARACTERISTICS

$V_{DD} = 3\text{ V to }3.6\text{ V}$, $T_A = -40^\circ\text{C to }85^\circ\text{C}$ (unless otherwise noted)

PARAMETER	TEST CONDITIONS	MIN	TYP	MAX	UNIT
$V_{(SR)}$ Input voltage range, $V_{(SR2)}$ and $V_{(SR1)}$	$V_{(SR)} = V_{(SR2)} - V_{(SR1)}$	-0.25		0.25	V
$V_{(SROS)}$ Input offset			1		μV
INL Integral nonlinearity error			0.004%	0.019%	

PLL SWITCHING CHARACTERISTICS

$V_{DD} = 3\text{ V to }3.6\text{ V}$, $T_A = -40^\circ\text{C to }85^\circ\text{C}$ (unless otherwise noted)

PARAMETER	TEST CONDITIONS	MIN	TYP	MAX	UNIT
$t_{(SP)}$ Start-up time ⁽¹⁾	0.5% frequency error		2	5	ms

(1) The frequency error is measured from the trimmed frequency of the internal system clock which is 128 oscillator frequency, nominally 4.194 MHz.

OSCILLATOR

$V_{DD} = 3\text{ V to }3.6\text{ V}$, $T_A = -40^\circ\text{C to }85^\circ\text{C}$ (unless otherwise noted)

PARAMETER	TEST CONDITIONS	MIN	TYP	MAX	UNIT
$f_{(exo)}$ Frequency error from 32.768 kHz	ROSC = 100 k Ω	-2%	0.25%	2%	
	ROSC = 100 k Ω , $V_{DD} = 3.3\text{ V}$	-1%	0.25%	1%	
	XCK1 = 12-pF XTAL	-0.25%		0.25%	
$f_{(sxo)}$ Start-up time ⁽¹⁾	ROSC = 100 k Ω			250	μs
	XCK1 = 12-pF XTAL			200	ms

(1) The start-up time is defined as the time it takes for the oscillator output frequency to be within 1% of the specified frequency.

DATA FLASH MEMORY CHARACTERISTICS

$V_{DD} = 3\text{ V to }3.6\text{ V}$, $T_A = -40^\circ\text{C to }85^\circ\text{C}$ (unless otherwise noted)

PARAMETER		TEST CONDITIONS	MIN	TYP	MAX	UNIT
t_{DR}	Data retention	See ⁽¹⁾	10			Years
	Flash programming write-cycles	See ⁽¹⁾	20,000			Cycles
$t_{(WORDPROG)}$	Word programming time	See ⁽¹⁾			2	ms
$I_{(DDPROG)}$	Flash-write supply current	See ⁽¹⁾		8	15	mA

(1) Specified by design. Not production tested

REGISTER BACKUP

$V_{DD} = 3\text{ V to }3.6\text{ V}$, $T_A = -40^\circ\text{C to }85^\circ\text{C}$ (unless otherwise noted)

PARAMETER		TEST CONDITIONS	MIN	TYP	MAX	UNIT
$I_{(RBI)}$	RBI data-retention input current	$V_{(RBI)} > 3\text{ V}$, $V_{DD} < V_{IT}$		10	100	nA
$V_{(RBI)}$	RBI data-retention voltage ⁽¹⁾		1.3			V

(1) Specified by design. Not production tested.

SMBus TIMING SPECIFICATIONS

$V_{DD} = 3\text{ V to }3.6\text{ V}$, $T_A = -40^\circ\text{C to }85^\circ\text{C}$ (unless otherwise noted)

PARAMETER		TEST CONDITIONS	MIN	TYP	MAX	UNIT
f_{SMB}	SMBus operating frequency	Slave mode, SMBC 50% duty cycle	10		100	kHz
f_{MAS}	SMBus master clock frequency	Master mode, no clock low slave extend		51.2		
t_{BUF}	Bus free time between start and stop		4.7			μs
$t_{HD:STA}$	Hold time after (repeated) start		4			
$t_{SU:STA}$	Repeated start setup time		4.7			
$t_{SU:STO}$	Stop setup time		4			
$t_{HD:DAT}$	Data hold time	Receive mode	0			ns
		Transmit mode	300			
$t_{SU:DAT}$	Data setup time		250			
$t_{TIMEOUT}$	Error signal/detect	See (1)	25		35	ms
t_{LOW}	Clock low period		4.7			μs
t_{HIGH}	Clock high period	See (2)	4		50	
$t_{LOW:SEXT}$	Cumulative clock low slave extend time	See (3)			25	ms
$t_{LOW:MEXT}$	Cumulative clock low master extend time	See (4)			10	
t_F	Clock/data fall time	$(V_{ILMAX} - 0.15\text{ V})$ to $(V_{IHMIN} + 0.15\text{ V})$			300	ns
t_R	Clock/data rise time	0.9 VDD to $(V_{ILMAX} - 0.15\text{ V})$			1000	

- (1) The bq20z80 times out when any clock low exceeds $t_{TIMEOUT}$.
- (2) $t_{HIGH:MAX}$ is minimum bus idle time. SMBC = 1 for $t > 50\ \mu\text{s}$ causes reset of any transaction involving the bq20z80 that is in progress.
- (3) $t_{LOW:SEXT}$ is the cumulative time a slave device is allowed to extend the clock cycles in one message from initial start to the stop.
- (4) $t_{LOW:MEXT}$ is the cumulative time a master device is allowed to extend the clock cycles in one message from initial start to the stop.

SMBus TIMING DIAGRAM

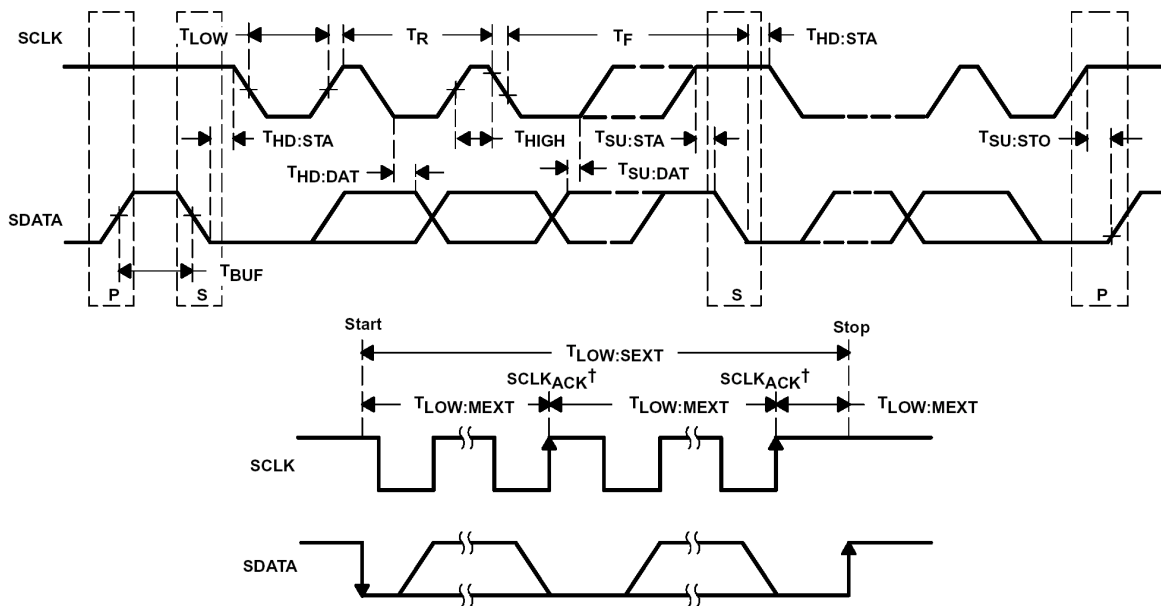

* $SCLK_{ACK}$ is the acknowledge-related clock pulse generated by the master.

FEATURE SET

NOTE

The bq20z80-V102 is designed to work with the bq29312A AFE. The bq20z80 features are only available with the bq29312A.

Primary (1st Level) Safety Features

The bq20z80 supports a wide range of battery and system protection features that are easily configured. The primary safety features include:

- Battery cell over/undervoltage protection
- Battery pack over/undervoltage protection
- 2 independent charge overcurrent protection
- 3 independent discharge overcurrent protection
- Short circuit protection
- Overtemperature protection
- Host watchdog

Secondary (2nd Level) Safety Features

The secondary safety features of the bq20z80 can be used to indicate more serious faults via the SAFE (pin 7) and $\overline{\text{SAFE}}$ (pin 12) pins. These pins can be used to blow an in-line fuse to permanently disable the battery pack from charging or discharging. The secondary safety features include:

- Safety over voltage
- Battery cell imbalance
- 2nd level protection IC input
- Safety overcurrent
- Safety overtemperature
- Open thermistor
- Charge FET and 0 Volt Charge FET fault
- Discharge FET fault
- Fuse blow failure detection
- AFE communication error
- Internal flash data error

Charge Control Features

The bq20z80 charge control features include:

- Report the appropriate charging current needed for constant current charging and the appropriate charging voltage needed for constant voltage charging to a smart charger using SMBus broadcasts.
- Determines the chemical state of charge of each battery cell using Impedance Track™ and can reduce the charge difference of the battery cells in fully charged state of the battery pack gradually using cell balancing algorithm during charging. This prevents fully charged cells from overcharging causing excessive degradation and also increases the usable pack energy by preventing early charge termination
- supports pre-charging/zero-volt charging
- support fast charging
- supports pulse charging
- detects charge termination
- report charging faults and also indicate charge status via charge and discharge alarms.

FEATURE SET (continued)

Gas Gauging

The bq20z80 uses the Impedance Track™ Technology to measure and calculate the available charge in battery cells. The achievable accuracy is better than the coulomb counting method over the lifetime of the battery and there is no full charge discharge learning cycle required.

See *Theory and Implementation of Impedance Track Battery Fuel-Gauging Algorithm* application note (SLUA364) for further details.

LED Display

The bq20z80 can drive 3-, 4-, or 5- segment LED display for remaining capacity indication.

LifeTime Data Logging Features

The bq20z80 offers a lifetime data logging array, where all important measurements are stored for warranty and analysis purposes. The data monitored includes:

- Lifetime maximum temperature
- Lifetime minimum temperature
- Lifetime maximum battery cell voltage
- Lifetime minimum battery cell voltage
- Lifetime maximum battery pack voltage
- Lifetime minimum battery pack voltage
- Lifetime maximum charge current
- Lifetime maximum discharge current
- Lifetime maximum charge power
- Lifetime maximum discharge power
- Lifetime maximum average discharge current
- Lifetime maximum average discharge power
- Lifetime average temperature

Authentication

The bq20z80 supports authentication by the host using SHA-1.

Power Modes

The bq20z80 supports 3 different power modes to reduce power consumption:

- In Normal Mode, the bq20z80 performs measurements, calculations, protection decision, data update in 1 second intervals. Between these intervals, the bq20z80 is in a reduced power stage.
- In Sleep Mode, the bq20z80 performs measurements, calculations, protection decision, data update in adjustable time intervals. Between these intervals, the bq20z80 is in a reduced power stage.
- In Shutdown Mode the bq20z80 is completely disabled.

CONFIGURATION

Oscillator Function

The oscillator of the bq20z80 can be set up for internal or external operation. On power up, the bq20z80 automatically attempts to start the internal oscillator. If a 100-k Ω resistor is not connected to ROSC (pin 33), then it attempts to start the oscillator using an external 32.768-kHz crystal.

NOTE

Install either the 100-k Ω ROSC resistor *or* the 12-pF, 32.768-kHz crystal. Do not install both.

FEATURE SET (continued)

The performance of the internal oscillator depends on the tolerance of the 100-k Ω resistor between RSOC (pin 33) and VSSA (pin 34). Choose a resistor with a tolerance of $\pm 0.1\%$, and 50-ppm or better temperature drift. Place this resistor as close as possible to the bq20z80. If a 12-pF crystal is used, place it as close as possible to the XCK1 (pin 34) and XCK2 (pin 33) pins. If not properly implemented, the PCB layout in this area can degrade oscillator performance.

System Present Operation

The bq20z80 pulls the PU pin high periodically (1 s). Connect this pin to the $\overline{\text{PRES}}$ pin of the bq20z80 via a resistor of approximately 5 k Ω . The bq20z80 measures the $\overline{\text{PRES}}$ input during the PU-active period to determine its state. If $\overline{\text{PRES}}$ input is pulled to ground by external system, the bq20z80 detects this as system present.

BATTERY PARAMETER MEASUREMENTS

The bq20z80 uses an integrating delta-sigma analog-to-digital converter (ADC) for current measurement, and a second delta-sigma ADC for individual cell and battery voltage, and temperature measurement.

Charge and Discharge Counting

The integrating delta-sigma ADC measures the charge/discharge flow of the battery by measuring the voltage drop across a small-value sense resistor between the SR1 and SR2 pins. The integrating ADC measures bipolar signals from -0.25 V to 0.25 V. The bq20z80 detects charge activity when $V_{\text{SR}} = V_{(\text{SR1})} - V_{(\text{SR2})}$ is positive and discharge activity when $V_{\text{SR}} = V_{(\text{SR1})} - V_{(\text{SR2})}$ is negative. The bq20z80 continuously integrates the signal over time, using an internal counter. The fundamental rate of the counter is 0.65 nVh.

Voltage

The bq20z80 updates the individual series cell voltages through the bq29312A at one second intervals. The bq20z80 configures the bq29312A to connect the selected cell, cell offset, or bq29312A VREF to the CELL pin of the bq29312A, which is required to be connected to VIN of the bq20z80. The internal ADC of the bq20z80 measures the voltage, scales and calibrates it appropriately. This data is also used to calculate the impedance of the cell for the Impedance Track™ gas-gauging.

Current

The bq20z80 uses the SR1 and SR2 inputs to measure and calculate the battery charge and discharge current using a 5 m Ω to 20 m Ω (typical) sense resistor.

Auto Calibration

The bq20z80 provides an auto-calibration feature to cancel the voltage offset error across SR1 and SR2 for maximum charge measurement accuracy. The bq20z80 performs auto-calibration when the SMBus lines stay low continuously for a minimum of 5 s.

Temperature

The bq20z80 TS1 and TS2 inputs, in conjunction with two identical NTC thermistors (default are Semitec 103AT), measure the battery environmental temperature. The bq20z80 can also be configured to use its internal temperature sensor.

COMMUNICATIONS

The bq20z80 uses SMBus v1.1 with Master Mode and package error checking (PEC) options per the SBS specification.

SMBus On and Off State

The bq20z80 detects an SMBus off state when SMBC and SMBD are logic-low greater than an adjustable period of time. Clearing this state requires either SMBC or SMBD to transition high. Within 1 ms, the communication bus is available.

FEATURE SET (continued)
SBS Commands
Table 1. SBS COMMANDS

SBS Cmd	Mode	Name	Format	Size in Bytes	Min Value	Max Value	Default Value	Unit
0x00	R/W	ManufacturerAccess	hex	2	0x0000	0xffff	—	
0x01	R/W	RemainingCapacityAlarm	unsigned int	2	0	65535	—	mAh or 10mWh
0x02	R/W	RemainingTimeAlarm	unsigned int	2	0	65535	—	min
0x03	R/W	BatteryMode	hex	2	0x0000	0xffff	—	
0x04	R/W	AtRate	signed int	2	–32768	32767	—	mA or 10mW
0x05	R	AtRateTimeToFull	unsigned int	2	0	65535	—	min
0x06	R	AtRateTimeToEmpty	unsigned int	2	0	65535	—	min
0x07	R	AtRateOK	unsigned int	2	0	65535	—	
0x08	R	Temperature	unsigned int	2	0	65535	—	0.1°K
0x09	R	Voltage	unsigned int	2	0	20000	—	mV
0x0a	R	Current	signed int	2	–32768	32767	—	mA
0x0b	R	AverageCurrent	signed int	2	–32768	32767	—	mA
0x0c	R	MaxError	unsigned int	1	0	100	—	%
0x0d	R	RelativeStateOfCharge	unsigned int	1	0	100	—	%
0x0e	R	AbsoluteStateOfCharge	unsigned int	1	0	100	—	%
0x0f	R	RemainingCapacity	unsigned int	2	0	65535	—	mAh or 10mWh
0x10	R	FullChargeCapacity	unsigned int	2	0	65535	—	mAh or 10mWh
0x11	R	RunTimeToEmpty	unsigned int	2	0	65535	—	min
0x12	R	AverageTimeToEmpty	unsigned int	2	0	65535	—	min
0x13	R	AverageTimeToFull	unsigned int	2	0	65535	—	min
0x14	R	ChargingCurrent	unsigned int	2	0	65535	—	mA
0x15	R	ChargingVoltage	unsigned int	2	0	65535	—	mV
0x16	R	BatteryStatus	unsigned int	2	0x0000	0xffff	—	
0x17	R/W	CycleCount	unsigned int	2	0	65535	—	
0x18	R/W	DesignCapacity	unsigned int	2	0	65535	—	mAh or 10mWh
0x19	R/W	DesignVoltage	unsigned int	2	7000	16000	14400	mV
0x1a	R/W	SpecificationInfo	unsigned int	2	0x0000	0xffff	0x0031	
0x1b	R/W	ManufactureDate	unsigned int	2	0	65535	0	
0x1c	R/W	SerialNumber	hex	2	0x0000	0xffff	0x0001	
0x20	R/W	ManufacturerName	String	11+1	—	—	Texas Instruments	ASCII
0x21	R/W	DeviceName	String	7+1	—	—	bq20z80	ASCII
0x22	R/W	DeviceChemistry	String	4+1	—	—	LION	ASCII
0x23	R	ManufacturerData	String	14+1	—	—	—	ASCII
0x2f	R/W	Authenticate	String	20+1	—	—	—	ASCII
0x3c	R	CellVoltage4	unsigned int	2	0	65535		mV
0x3d	R	CellVoltage3	unsigned int	2	0	65535		mV
0x3e	R	CellVoltage2	unsigned int	2	0	65535		mV
0x3f	R	CellVoltage1	unsigned int	2	0	65535		mV

Table 2. EXTENDED SBS COMMANDS

SBS Cmd	Mode	Name	Format	Size in Bytes	Min Value	Max Value	Default Value	Unit
0x45	R	AFEData	String	11+1	—	—	—	ASCII
0x46	R/W	FETControl	hex	1	0x00	0xff	—	
0x4f	R	StateOfHealth	unsigned int	1	0	100	—	%
0x50	R	SafetyAlert	hex	2	0x0000	0xffff	—	
0x51	R	SafetyStatus	hex	2	0x0000	0xffff	—	
0x52	R	PFAAlert	hex	2	0x0000	0xffff	—	
0x53	R	PFStatus	hex	2	0x0000	0xffff	—	
0x54	R	OperationStatus	hex	2	0x0000	0xffff	—	
0x55	R	ChargingStatus	hex	2	0x0000	0xffff	—	
0x57	R	ResetData	hex	2	0x0000	0xffff	—	
0x58	R	WDRResetData	unsigned int	2	0	65535	—	
0x5a	R	PackVoltage	unsigned int	2	0	65535	—	mV
0x5d	R	AverageVoltage	unsigned int	2	0	65535	—	mV
0x60	R/W	UnSealKey	hex	4	0x00000000	0xffffffff	—	
0x62	R/W	PFKey	hex	4	0x00000000	0xffffffff	—	
0x63	R/W	AuthenKey3	hex	4	0x00000000	0xffffffff	—	
0x64	R/W	AuthenKey2	hex	4	0x00000000	0xffffffff	—	
0x65	R/W	AuthenKey1	hex	4	0x00000000	0xffffffff	—	
0x66	R/W	AuthenKey0	hex	4	0x00000000	0xffffffff	—	
0x70	R/W	ManufacturerInfo	String	8+1	—	—	—	
0x71	R/W	SenseResistor	unsigned int	2	0	65535	—	μΩ
0x77	R/W	DataflashClass	hex	2	0x0000	0xffff	—	
0x78	R/W	DataFlashSubClass1	hex	32	—	—	—	
0x79	R/W	DataFlashSubClass2	hex	32	—	—	—	
0x7a	R/W	DataFlashSubClass3	hex	32	—	—	—	
0x7b	R/W	DataFlashSubClass4	hex	32	—	—	—	
0x7c	R/W	DataFlashSubClass5	hex	32	—	—	—	
0x7d	R/W	DataFlashSubClass6	hex	32	—	—	—	
0x7e	R/W	DataFlashSubClass7	hex	32	—	—	—	
0x7f	R/W	DataFlashSubClass8	hex	32	—	—	—	

Firmware Version Changes

bq20z80-V102 to bq20z80-V110 Changes

Table 3. CHANGE DETAILS

CHANGE	bq0z80-V110	bq20z80-V102	COMMENTS
Allows alarm based on remaining battery energy	<i>DF.Remaining Energy Alarm</i> added	Feature not available	make bq20z80 compatible to bq20z90
Permanent fail fuse blow can be disabled, if IT not enabled	<i>[PRE_ZT_PF_En]</i> in <i>DF.Operation Cfg C</i> added	Feature not available	prevents accidental fuse blow during production and testing
changed max time the LED stays on after display is activated	<i>DF.LED Hold Time</i> max time is 16s	<i>DF.LED Hold Time</i> max time is 255s	reliable LED display timings
Prevent false detection of AFE_C	Reset AFE comm and clear the <i>afe_fail</i> count in case AFE in unknown comm state at reset		Prevents a AFE_C during a WD Reset

Table 3. CHANGE DETAILS (continued)

CHANGE	bq0z80-V110	bq20z80-V102	COMMENTS
Proper FET operation in presence of partial resets	Clear sleep mode flag (and all Sbscc_control flags) with partial and full resets to correct condition where charge FET can remain off.	CHG_off flag set while in SLEEP but a partial reset would incorrectly clear this flag	
Prevent false detection of PF	Force full reset for attempted shutdown (prevent PF_SHUT from causing a PF condition if shutdown does not occur)	Shutdown does cause a PF	
Allow shutdown to work correctly when the part is in sleep	Fix shutdown when in sleep	A race condition was occurring between sleep and shutdown that was not allowing the device to shutdown when in sleep mode.	
Change default charger present voltage from 12000 to 3000 mv	Change default charger present voltage from 12000 to 3000 mv	bq29312 will not reliably shutdown until pack+ voltage is below 3000 mv. Prevents failed shutdown attempts	
Meet SBS specification	Change default DF:Rem Cap Alarm for mWh mode to 10% of DF:Design Capacity per SBS spec from 0		
Meet SBS specification	Correct SBS.AbsoluteStateOfCharge() to allow for values >100% per SBS the spec		
Correct cell balance time when number of cells < 4	cell balance duty cycle now 0.4	"Cell balancing time per cell has been changed to be based on the number of cells configured for use in Operation Cfg A, as below. Each number indicates the duty cycle, or the amount of time the cell balancing FET is on as opposed to being off. For example, if the duty cycle is 0.4, and the cycle time is 250 ms, the cell balancing FET will be on for 100 ms and off for 150 ms.CC1:CC0 = 3 -> 0.4CC1:CC0 = 2 -> 0.3CC1:CC0 = 1 -> 0.224"	
For persistent SC conditions	Change Default AFE OC Dsg Recovery from 100 mA to 5 ma		
	Set SBS.BatteryMode Alarm and charger bits default to on if master broadcasts disabled.		Convenient setup to have BatteryMode Alarm accurately indicate broadcast state.
	Make RemainingCapacity writeable		
	Add State of Health parameter		
unused data flash	Remove unused FastCharge OverVoltage	double dataflash value	
Faster wakeup response	Check sleep wakeup every 250 ms, change from 1000 ms	Check sleep wakeup every 1000 ms	

bq20z80-V101 to bq20z80-V102 Changes
Table 4. CHANGE DETAILS

CHANGE	bq0z80-V102	bq20z80-V101	COMMENTS
Corrected to allow display to turn off when charging and button pushed.	LED display operates correctly during charging.	LED display would stay on until charging terminated after the button was pushed. Only occurs when LED display not configured to be always on during charging.	Correct operation of the LED display under all conditions

Table 4. CHANGE DETAILS (continued)

CHANGE	bq0z80-V102	bq20z80-V101	COMMENTS
Allow negative LED thresholds to permit LED alarms to be disabled	Configuring negative LED alarm threshold disables LED alarm functionality.	Feature not available	Allow better customization
Allow zero values for ALARM and CHARGING LED blink rates to disable them	Configuring zero value for the LED blink rates disables them.	Feature not available	Allow better customization
Restore initialization of dodcharge in relaxed state so that the correct dodcharge value is used in capacity estimation	dodcharge initialized to the correct value	dodcharge value set to zero	Improved gauging accuracy with correct initialization of dodcharge value.
Only clear offset calibration flag when SMBus lines go high.	Prevents offset calibration occurring just because a safety condition occurs and then clears when the SMBus lines are low.	Offset calibration occurs multiple times if safety condition occurs when SMBus lines are low.	More appropriate period between offset calibrations when SMBus lines are low.
Change so that setting AFE Fail Limit to zero disables PF_AFE_C	Configurable option to allow disabling PF_AFE_C trigger	Feature not available.	Allow better customization
Enable LED display to turn off after charge termination and if SMBus lines are detected low and LEDs enabled during charging.	LED display turns off after charge termination.	LED display stays on when charging terminates after SMBus lines are detected low.	Correct operation of the LED display under all conditions
Set charge FET state immediately when entering sleep	Charge FET state set correctly, immediately after entering sleep	The CHG FET would not get set to the correct state for sleep until the first voltage measurement.	Quicker transition of FET to the correct state in sleep
Change <i>DF:Operation Cfg B [CCT = 0]</i> , so that <i>SBS.CycleCount()</i> threshold is in mAH, not in % of FCC	Data flash default bases <i>SBS.CycleCount()</i> calculation on mAH and not % of FCC	<i>DF:Operation Cfg B [CCT = 1]</i> , making the default <i>SBS.CycleCount()</i> calculation to be based on % of FCC	Data flash default changed to reflect common customer usage
When <i>DF:Operation Cfg B [CCT = 1]</i> , so that <i>SBS.CycleCount()</i> threshold is % of FCC, then <i>DF:CC Threshold</i> is used as a minimum for the <i>SBS.CycleCount()</i> threshold	Use <i>DF:CC Threshold</i> as the minimum to prevent rapid incrementing of the <i>SBS.Cyclecount()</i> , damaging the data flash	Small or negative <i>SBS.Full Charge Capacity()</i> values (should not occur under normal operation) from causing the <i>SBS.CycleCount()</i> incrementing rapidly, potentially damaging the data flash	Improved system reliability
When exiting the relaxed state to sleep, the initial charge capacity is correctly calculated	Corrected initial charge capacity calculation to be accurate when exiting relaxed state to sleep	If the relaxed state was exited to sleep after a valid DOD measurement (30-minute default value), then the initial charge capacity would not be recalculated and would result in an incorrect FCC value if the sleep state was exited before another valid DOD measurement (30-minute default value)	More reliable <i>SBS:FullChargeCapacity()</i> calculation under all system conditions
Correct update of Remcap in relaxed state to use passed charge	Charge or discharge current accumulated in a relaxed state used to update Remcap	If the relaxed state was exited after the accumulation of significant charge or discharge current (over at most 100 seconds with default values), the RemCap and FCC would be in error by this charge. This is only significant if the relaxed state can exist with significant current as determined by application settings.	More reliable <i>SBS:FullChargeCapacity()</i> <i>SBS:RemainingCapacity()</i> calculation under all system conditions

Table 4. CHANGE DETAILS (continued)

CHANGE	bq0z80-V102	bq20z80-V101	COMMENTS
Implement disable of resistance update based on accumulative scale. If the product of 15 consecutive (default value) resistance scale factors is less than 0.5 or more than 1.5, then resistance update is disabled until the next valid soc measurement. Sets bit 2 of Operation Status to indicate resistance update disabled.	Prevent invalid soc values from causing incorrect resistance updates	Incorrect resistance updates that could result from invalid soc values	More reliable resistance updates under all system conditions
Implement disable of resistance update based on estimated capacity error. Sets bit 2 of Operation Status to indicate resistance update disabled.	Prevent invalid soc values from causing incorrect resistance updates	Incorrect resistance updates that could result from invalid soc values	More reliable resistance updates under all system conditions
Disable Qmax increment if due to Grid 14 and exit of discharge	Prevent unnecessary Qmax increments	Qmax increments can occur due to Grid 14 and exit of discharge	Improved Qmax data reliability under all system conditions.
Drive all unused pins low	Provides better ESD immunity	Not all unused pins driven low	Improved ESD immunity
Initial charge capacity calculation when dod0 is measured in the overdischarged state is corrected	Overdischarged state does not affect the accuracy of FCC calculations	An incorrect initial charge capacity affects FCC that is calculated during discharge or a Qmax update. If FCC is not changed by a Qmax update, then reported RemainingCapacity could be negative after 5 hours of relaxation	More reliable <i>SBS:FullChargeCapacity()</i> <i>SBS:RemainingCapacity()</i> calculation under all system conditions
Correct calculation of FCC and RemCap when dod0 is taken when the battery is overdischarged or overcharged. This allows RemCap to go negative, or greater than FCC (though is only reported from 0 - FCC).	Overcharged/Overdischarged does not affect the accuracy of FCC and RemCap calculations	The RemainingCapacity will increment (or decrement) during charging (discharging) even when the battery is in an overdischarged (overcharged) state.	More reliable <i>SBS:FullChargeCapacity()</i> <i>SBS:RemainingCapacity()</i> calculation under all system conditions
Change cell imbalance <i>DF:Battery Rest Time</i> from 1 byte to 2 bytes and set the default value to 1800 seconds	New feature providing improved customization	Feature not available	Improved customization for Cell Imbalance detection
Use upper and lower limit for resistance accumulative scale. Set default values to 300% and 30%.			More reliable resistance updates under all system conditions
Add <i>DF:CF MaxError limit</i> for setting <i>SBS.BatteryMode()</i> [CONDITION FLAG]. Set default value to 100%.	New feature providing improved customization	Feature not available	Improved customization
Use <i>SBS.AtRate()</i> , <i>UserRate</i> and <i>C/5</i> rate for relaxed capacity calculation, respectively, if set by Load Select; otherwise, use previous rate.			More reliable <i>SBS:FullChargeCapacity()</i> <i>SBS:RemainingCapacity()</i> calculation under all system conditions
Correct Host Watchdog from being reset by broadcasts	Host Watchdog functionality not affected by alarm or charger broadcasts	Host Watchdog reset by alarm or charger broadcasts	Reliable Host Watchdog functionality under all system conditions

Table 4. CHANGE DETAILS (continued)

CHANGE	bq0z80-V102	bq20z80-V101	COMMENTS
The voltage table chemistry ID can be read by writing 0x0008 to ManufacturerAccess and then reading from ManufacturerAccess. The default chemistry ID is 0x0100	New feature providing more information	Feature not available	Improved information access
<i>SBS.BatteryMode()</i> is initialized on high transition of the SMBus lines to <i>DF:Init BatteryMode</i> , instead of always clearing <i>SBS.BatteryMode()</i> defined bits on high transition of the SMBus lines.	Customization allows for preserving <i>SBS.BatteryMode()</i> settings through SMBus line transitions	Feature not available	Improved customization
Broadcast timers are set correctly on high transition of SMBus lines. The timers are set to 10 seconds on high transition of SMBus lines.	Broadcast timer accurate regardless of CC offset calibration or entry to sleep	Broadcast timer accuracy required a CC offset calibration and entry to sleep.	Improved broadcast timing accuracy to meet Smart Battery Data spec

bq20z80 to bq20z80-V101 Changes

CHANGE	bq20z80	bq20z80-V101	COMMENTS
Added authentication (optional SBS command 0x2f)	Command 0x2f has no function and is not acknowledged.	Command 0x2f is the <i>SBS.Authenticate()</i> command to the bq20z80 to begin the SHA1 authentication.	Additional feature to enable host to authenticate the battery
Added Cell Balancing	Cell balancing not available	Added State of Charge cell balancing algorithm	Additional feature to enable longer lifetime of battery
Added charge fault FET Enable register	When charge faults occur, FET action is taken.	When charge faults occur, FET action is taken if enabled in <i>DF:FET Enable</i> register.	Adds flexibility to system interaction
Added pulse compensation for end of discharge	Applications with pulsed current loads and minimum voltage requirements can have less RemainingCapacity than reported.	The voltage pulses caused by pulsed current loads are measured and used to better estimate RemainingCapacity.	Added additional feature to improve capacity prediction
Added <i>SBS.BatteryStatus()</i> [TDA, FD] voltage thresholds	<i>SBS.BatteryStatus()</i> [TDA, FD] are only set on SBS.RSOC, detection of charge termination or faults	<i>SBS.BatteryStatus()</i> [TDA, FD] are now set and cleared based on <i>SBS.Voltage()</i>	Adds flexibility to system interaction
Added option for LEDs in series with current source	LED display is only in parallel.	LED display is available in series (with current source) or parallel.	Adds capability for higher brightness LEDs
Configured pin 7 as active high fuse blow	Pin 7 is not connected.	Pin 7 is now an active high reflection of SAFE (pin 12).	Adds flexibility to choose different circuits driven by the permanent failure signal
Added State of Health calculation (command 0x4f)	Command 0x4f has no function and is not acknowledged.	Command 0x4f is the <i>SBS.StateOfHealth()</i> command where SOH is the ratio of <i>SBS.DesignCapacity()</i> to <i>SBS.FullChargeCapacity()</i> .	Additional feature to allow host to easily determine health of the battery
Added Synchronization of <i>SBS.RemainingCapacity()</i> to <i>SBS.FullChargeCapacity()</i> at charge taper termination.	<i>SBS.RemainingCapacity()</i> is not affected and could be < 100% at charge termination.	If <i>DF:Operation Cfg [RMFCC]</i> is set then <i>SBS.RemainingCapacity()</i> is updated to the value of <i>SBS.FullChargeCapacity()</i> at charge termination.	Adds option to enable charge synchronization in order to display RelativeStateOfCharge as 100% at charge termination
Improved thermal model	A preliminary thermal mode was used.	An updated thermal model is used.	Improved thermal compensation of Impedance Track™ algorithm
Improved cell capacity measurement by limiting valid temperature ranges	Valid voltage measurements for cell capacity estimation can occur at any temperature.	Valid voltage measurements for cell capacity estimation must occur within a defined temperature range.	Improves capacity estimation
Improved cell capacity measurement	After a full reset, it may take several minutes for voltage reading to settle to the most accurate reading.	Settling time of voltage measurements after a full reset is reduced.	Improves initial voltage reading accuracy
Improved default resistance tables	A preliminary default resistance mode was used.	An updated default resistance mode is used.	Improved thermal accuracy of Impedance Track™ algorithm

CHANGE	bq20z80	bq20z80-V101	COMMENTS
Prevented lifetime updates until IT is enabled	Data flash lifetime data is updated under all conditions.	Data flash lifetime data is not updated until Impedance Track™ is enabled.	Improves suitability of lifetime data
Aligned SBS.RemainingCapacity() with DF:Terminate Voltage	SBS.RemainingCapacity() could be above zero when SBS.Voltage() reaches DF:Terminate Voltage.	Forces SBS.RemainingCapacity() to zero when SBS.Voltage() is below terminate voltage	Improves alignment between reporting and system status
Disabled LEDs for undervoltage conditions	When SBS.OperationStatus() [CUV or PUV] is set, then the LED display could be activated.	When SBS.OperationStatus() [CUV or PUV] is set, the LED display is disabled.	Reduces risk of deeply discharging the battery
Clear SBS.BatteryStatus() [RCA] when not SBS.BatteryStatus() [DSG]	SBS.BatteryStatus() [RCA] is not cleared when SBS.BatteryStatus() [DSG] is cleared.	SBS.BatteryStatus() [RCA] is now cleared when SBS.BatteryStatus() [DSG] is cleared.	Corrected to meet SBS specification
Allowed sleep mode for undervoltage conditions	When SBS.OperationStatus() [CUV or PUV] is set, then entry to sleep mode is disabled.	When SBS.OperationStatus() [CUV or PUV] is set, then entry to sleep mode is allowed.	Reduces risk of deeply discharging the battery
Improvements made to Lifetime data	Does not save maximum and minimum lifetime AverageCurrent or AveragePower. Only saves lifetime data when new values exceed old values by defined delta values	Saves maximum and minimum lifetime AverageCurrent and AveragePower. Lifetime data is saved after a defined period of time even if new values do not exceed old values by defined delta values	Improves lifetime data
Changes made to pulse charging	Voltages for pulse charging are sampled once a second.	Voltages for pulse charging are sampled 4 times a second.	Improves pulse charging
Changes made to charging timeouts	The precharge timeout timer runs when the charging current is below a defined threshold; so, it is possible that the precharge timer will run during charging taper current and cause an undesired precharge timeout during charging taper.	The fast charge and precharge timeout timers only run when precharging or charging, as indicated by FCHG and PCHG bits in ChargingStatus.	Improves operation of fast charge and precharge timeout timers
Changes made to discharge faults	Discharging fault is indicated whenever BatteryStatus [TDA] is set. Current discharging fault is not indicated for current faults detect by AFE. Separate discharging faults are indicated for voltage and temperature.	Discharging fault is indicated for any safety condition resulting in turning off the discharge FET. Current discharging fault is indicated for all detected overcurrent conditions, including overcurrent detected by AFE. Temperature and voltage discharge faults are not indicated separately.	Improves indication of discharging fault conditions
Improvements made to calibration functions	Voltage calibration functions may cause error in voltage calibration of several millivolts.	Voltage calibration functions are capable of accuracy within 1 millivolt.	Improved voltage calibration accuracy
Protect against simultaneous writes to data flash	A SMBus-initiated data flash write may occur at the same time as a data flash write initiated by the AGG, which may cause a data flash write error.	A SMBus-initiated data flash write cannot occur at the same time as any other data flash write.	Increased robustness of data flash writes
Corrected SBS.ManufacturerAccess() access of silicon revision	SBS.ManufacturerAccess() access of silicon revision is not functional.	SBS.ManufacturerAccess() access of silicon revision is functional.	Allows host to determine bq20z80 silicon revision
Corrected data flash checksum operation	The data flash checksum includes non-accessible portions of the data flash that change when writing the data flash checksum, invalidating the checksum.	The data flash checksum only includes data flash that does not change when writing an updated data flash checksum.	Data flash checksum operation works correctly.
Corrections made to LED display	Fixed LED thresholds cannot be selected.	Fixed LED thresholds can be selected.	Correct operation of LED threshold settings
Erroneous readings are corrected that occurred after offset calibration when sleep mode is not entered.	Erroneous SBS voltage, current, and temperature readings occur after current offset calibration if sleep mode is not entered, corrupting the lifetime data.	No erroneous SBS voltage, current, and temperature readings occur after current offset calibration if sleep mode is not entered.	Improve reliability of lifetime data
Corrected the length of SBS.ManufacturerData() command	SBS.ManufacturerData() returned additional data not specified in the data sheet.	Only returns the appropriate data	Correct data set made available to host
Changed DF:Charger Present default voltage to 12000 mV	DF:Charger Present default was 16800 mV.	Default changed to 12000 mV.	More realistic default for most applications
Corrected LED display lock-up fault when exiting sleep with LEDs on	LED display locks up if LEDs are ON as the bq20z80 exits sleep mode.	LED display operates normally regardless of power state transitions.	Correct operation of the LED display under all conditions

CHANGE	bq20z80	bq20z80-V101	COMMENTS
Added report of any inability to write DFF as flash write error in calibration mode	If writing the data flash is not allowed either due to a permanent failure or low voltage, then no indication is given when attempting to write data flash in calibration mode.	The inability to write data flash in calibration mode is reported as a flash write error.	Improved calibration system interaction
Corrected issue of improperly clearing AFE faults	AFE faults were detected and the pack protected but the fault would be cleared up to three times at an interval of 250 milliseconds before the defined recovery requirements would apply.	AFE faults are correctly handled, including the flags.	Improved system interaction when faults occur
Modified code to save open-circuit voltage (OCV) data on IT enable only, not a full reset	OCV data was saved after a full reset which could have disturbed the OCV measurements if the battery was not in a completely relaxed state.	OCV tables are only updated when IT enabled, or the IT enable command is resent.	Improved OCV data reliability under all system conditions
Corrected range check for calibration of analog-to-digital converter (ADC) offset	In calibration mode, if the measurement ADC offset was out of range, no error would be reported.	In calibration mode, if the measurement ADC offset is out of range, an error is reported.	Improved calibration system interaction
Implemented a validation time for DOD0	There is a possibility of erroneous DOD0 measurement if charge or discharge current occurs at the same time.	DOD0 measurement is not saved unless the battery remains in the relaxed state for a defined time after the DOD0 measurement is made.	More reliable SBS.FullChargeCapacity() and SBS.RemainingCapacity under all system conditions
Implemented a bounds limit to a QMAX change	QMAX changes are not limited to filter-bad readings.	QMAX changes are bounds limited to filter-bad readings.	More reliable SBS.FullChargeCapacity() and SBS.RemainingCapacity under all system conditions
Implemented a double hit for dv/dt detection for QMAX qualification	The dv/dt qualification for QMAX update requires only one sample to be valid.	The dv/dt qualification for QMAX update requires two samples to be valid.	More reliable SBS.FullChargeCapacity() and SBS.RemainingCapacity() under all system conditions
Corrected parameter update issue caused by exiting sleep mode during current measurement	If bq20z80 exits sleep during a current measurement, the SBS parameters do not update again until the pack enters and exits sleep mode again.	SBS parameter updates operate normally regardless of power state transitions.	Improved system interaction for sleep mode transitions
Implemented an option to leave charge FET on for a nonremovable pack in sleep mode, enabled by DF:Operation Cfg B [NRCHG].	When DF:Operation Cfg B [NR] is set, then the CHG is turned off at entry to sleep mode.	When DF:Operation Cfg B [NR, NRCHG] are set, then the CHG remains on at entry to sleep mode.	Improved system interaction options
Modified code such that if QMAX has not been updated, old valid OCV readings are discarded when a new valid OCV reading is detected and the conditions for QMAX update do not exist.	Valid OCV is only discarded when all conditions for QMAX update are satisfied, but the accumulated error in the measured capacity exceeds 1% (default value).	If QMAX has been updated, the same conditions for discarding an OCV reading are the same as for the bq20z80. Otherwise, old OCV readings are discarded and new OCV readings are used when the conditions for a valid OCV reading exist, but the conditions for QMAX update do not exist.	Enables QMAX measurement for full charge or discharge for the first QMAX update, even if initial OCV measurement is made when battery is only partially charged.
Modified code such that if QMAX has not been updated, then for QMAX update to occur, the measured capacity must be greater than or equal to 90% (default value) of design capacity.	The measured capacity must be greater than 20% (default value) or a value as determined from the QMAX update filter constant for a QMAX update to occur.	For the first QMAX, the measured capacity must be greater than 90% (default value) for a QMAX update to occur. If QMAX update has occurred the conditions for measured capacity are the same as for the bq20z80.	Improved QMAX data reliability for the first update of QMAX
Default minimum passed charge for QMAX update has been changed from 20% to 37%	Internal flash value of Min Passed Charge is 20%. The default setting for the QMAX update filter constant of 64 means actual Min Passed Charge for QMAX update is 25%.	Internal flash value of Min Passed Charge is 37%. This 37% is consistent with the QMAX update filter constant of 96.	Improved QMAX data reliability under all system conditions.
Default QMAX update filter constant has been changed from 64 to 94.	Internal flash value of QMAX update filter is 64.	Internal flash value of QMAX update filter is 94.	Improved QMAX data reliability under all system conditions.
QMAX values for nonexistent cells will be updated to Design Capacity.	DF:Qmax Cell 2..4 written with random values if not used when QMAX is updated	DF:Qmax Cell 2..4 are updated to = DF:Design Capacity if not used when QMAX is updated.	Ensure all QMAX values are reasonable, even if not used

PACKAGING INFORMATION

Orderable Device	Status (1)	Package Type	Package Drawing	Pins	Package Qty	Eco Plan (2)	Lead finish/ Ball material (6)	MSL Peak Temp (3)	Op Temp (°C)	Device Marking (4/5)	Samples
BQ20Z80ADBT-V110	ACTIVE	TSSOP	DBT	38	50	RoHS & Green	NIPDAU	Level-2-260C-1 YEAR	-40 to 85	20Z80A	Samples
BQ20Z80ADBTR-V110	ACTIVE	TSSOP	DBT	38	2000	RoHS & Green	NIPDAU	Level-2-260C-1 YEAR	-40 to 85	20Z80A	Samples
BQ20Z80DBT	ACTIVE	TSSOP	DBT	38	50	RoHS & Green	NIPDAU	Level-2-260C-1 YEAR	-40 to 85	20Z80DBT	Samples
BQ20Z80DBTR-V110	ACTIVE	TSSOP	DBT	38	2000	RoHS & Green	NIPDAU	Level-2-260C-1 YEAR	-40 to 85	20Z80DBT	Samples

(1) The marketing status values are defined as follows:

ACTIVE: Product device recommended for new designs.

LIFEBUY: TI has announced that the device will be discontinued, and a lifetime-buy period is in effect.

NRND: Not recommended for new designs. Device is in production to support existing customers, but TI does not recommend using this part in a new design.

PREVIEW: Device has been announced but is not in production. Samples may or may not be available.

OBSELETE: TI has discontinued the production of the device.

(2) **RoHS:** TI defines "RoHS" to mean semiconductor products that are compliant with the current EU RoHS requirements for all 10 RoHS substances, including the requirement that RoHS substance do not exceed 0.1% by weight in homogeneous materials. Where designed to be soldered at high temperatures, "RoHS" products are suitable for use in specified lead-free processes. TI may reference these types of products as "Pb-Free".

RoHS Exempt: TI defines "RoHS Exempt" to mean products that contain lead but are compliant with EU RoHS pursuant to a specific EU RoHS exemption.

Green: TI defines "Green" to mean the content of Chlorine (Cl) and Bromine (Br) based flame retardants meet JS709B low halogen requirements of <=1000ppm threshold. Antimony trioxide based flame retardants must also meet the <=1000ppm threshold requirement.

(3) MSL, Peak Temp. - The Moisture Sensitivity Level rating according to the JEDEC industry standard classifications, and peak solder temperature.

(4) There may be additional marking, which relates to the logo, the lot trace code information, or the environmental category on the device.

(5) Multiple Device Markings will be inside parentheses. Only one Device Marking contained in parentheses and separated by a "-" will appear on a device. If a line is indented then it is a continuation of the previous line and the two combined represent the entire Device Marking for that device.

(6) Lead finish/Ball material - Orderable Devices may have multiple material finish options. Finish options are separated by a vertical ruled line. Lead finish/Ball material values may wrap to two lines if the finish value exceeds the maximum column width.

Important Information and Disclaimer:The information provided on this page represents TI's knowledge and belief as of the date that it is provided. TI bases its knowledge and belief on information provided by third parties, and makes no representation or warranty as to the accuracy of such information. Efforts are underway to better integrate information from third parties. TI has taken and

continues to take reasonable steps to provide representative and accurate information but may not have conducted destructive testing or chemical analysis on incoming materials and chemicals. TI and TI suppliers consider certain information to be proprietary, and thus CAS numbers and other limited information may not be available for release.

In no event shall TI's liability arising out of such information exceed the total purchase price of the TI part(s) at issue in this document sold by TI to Customer on an annual basis.

TAPE AND REEL INFORMATION

QUADRANT ASSIGNMENTS FOR PIN 1 ORIENTATION IN TAPE

*All dimensions are nominal

Device	Package Type	Package Drawing	Pins	SPQ	Reel Diameter (mm)	Reel Width W1 (mm)	A0 (mm)	B0 (mm)	K0 (mm)	P1 (mm)	W (mm)	Pin1 Quadrant
BQ20Z80ADBTR-V110	TSSOP	DBT	38	2000	330.0	16.4	6.9	10.2	1.8	12.0	16.0	Q1

TAPE AND REEL BOX DIMENSIONS

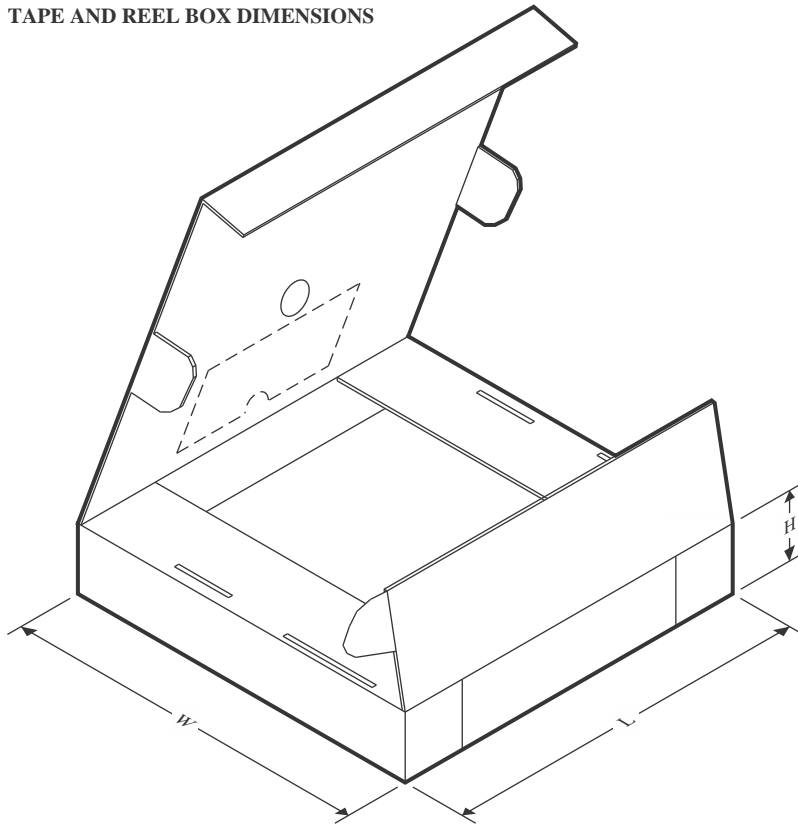

*All dimensions are nominal

Device	Package Type	Package Drawing	Pins	SPQ	Length (mm)	Width (mm)	Height (mm)
BQ20Z80ADBTR-V110	TSSOP	DBT	38	2000	367.0	367.0	38.0

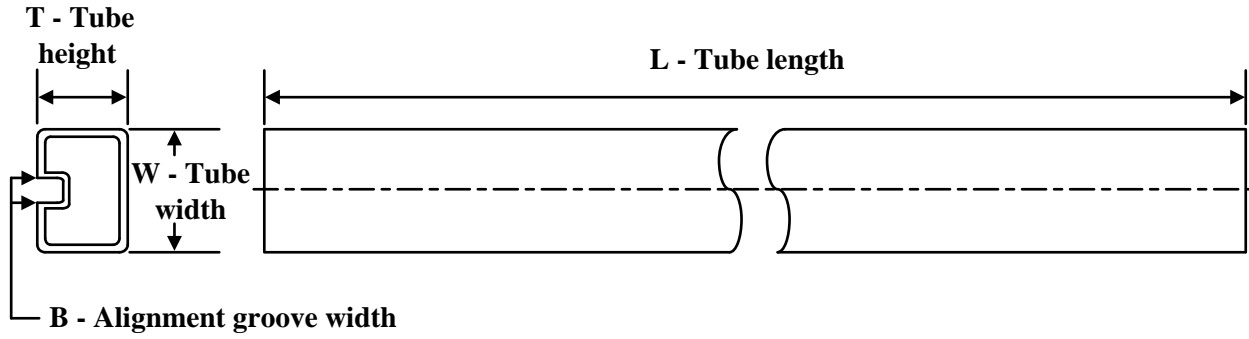
TUBE

*All dimensions are nominal

Device	Package Name	Package Type	Pins	SPQ	L (mm)	W (mm)	T (μm)	B (mm)
BQ20Z80ADBT-V110	DBT	TSSOP	38	50	530	10.2	3600	3.5
BQ20Z80DBT	DBT	TSSOP	38	50	530	10.2	3600	3.5

PACKAGE OUTLINE

DBT0038A

TSSOP - 1.2 mm max height

SMALL OUTLINE PACKAGE

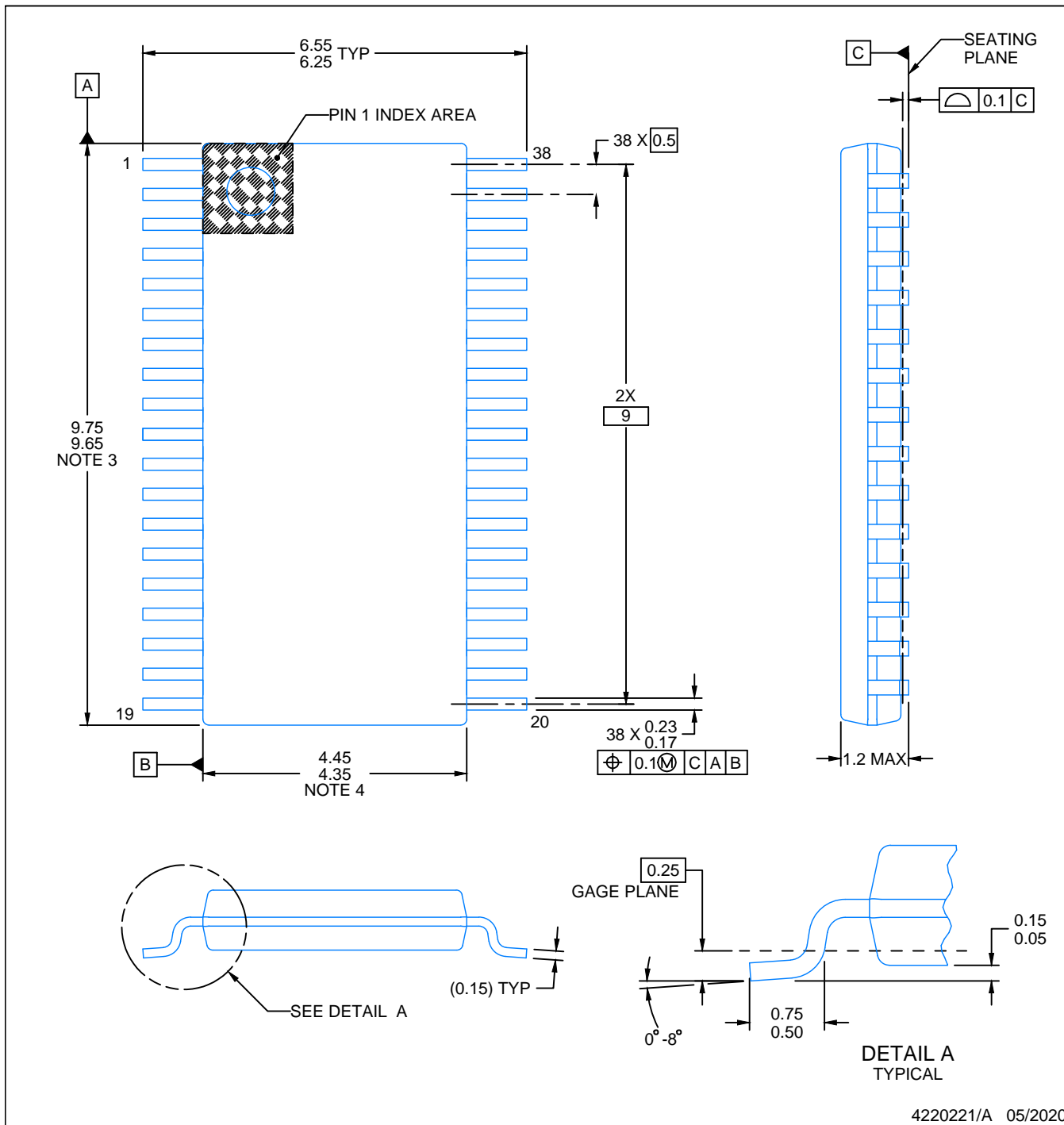

NOTES:

1. All linear dimensions are in millimeters. Any dimensions in parenthesis are for reference only. Dimensioning and tolerancing per ASME Y14.5M.
2. This drawing is subject to change without notice.
3. This dimension does not include mold flash, protrusions, or gate burrs. Mold flash, protrusions, or gate burrs shall not exceed 0.15 mm per side.
4. This dimension does not include interlead flash. Interlead flash shall not exceed 0.25 mm per side.
5. Reference JEDEC registration MO-153.

EXAMPLE BOARD LAYOUT

DBT0038A

TSSOP - 1.2 mm max height

SMALL OUTLINE PACKAGE

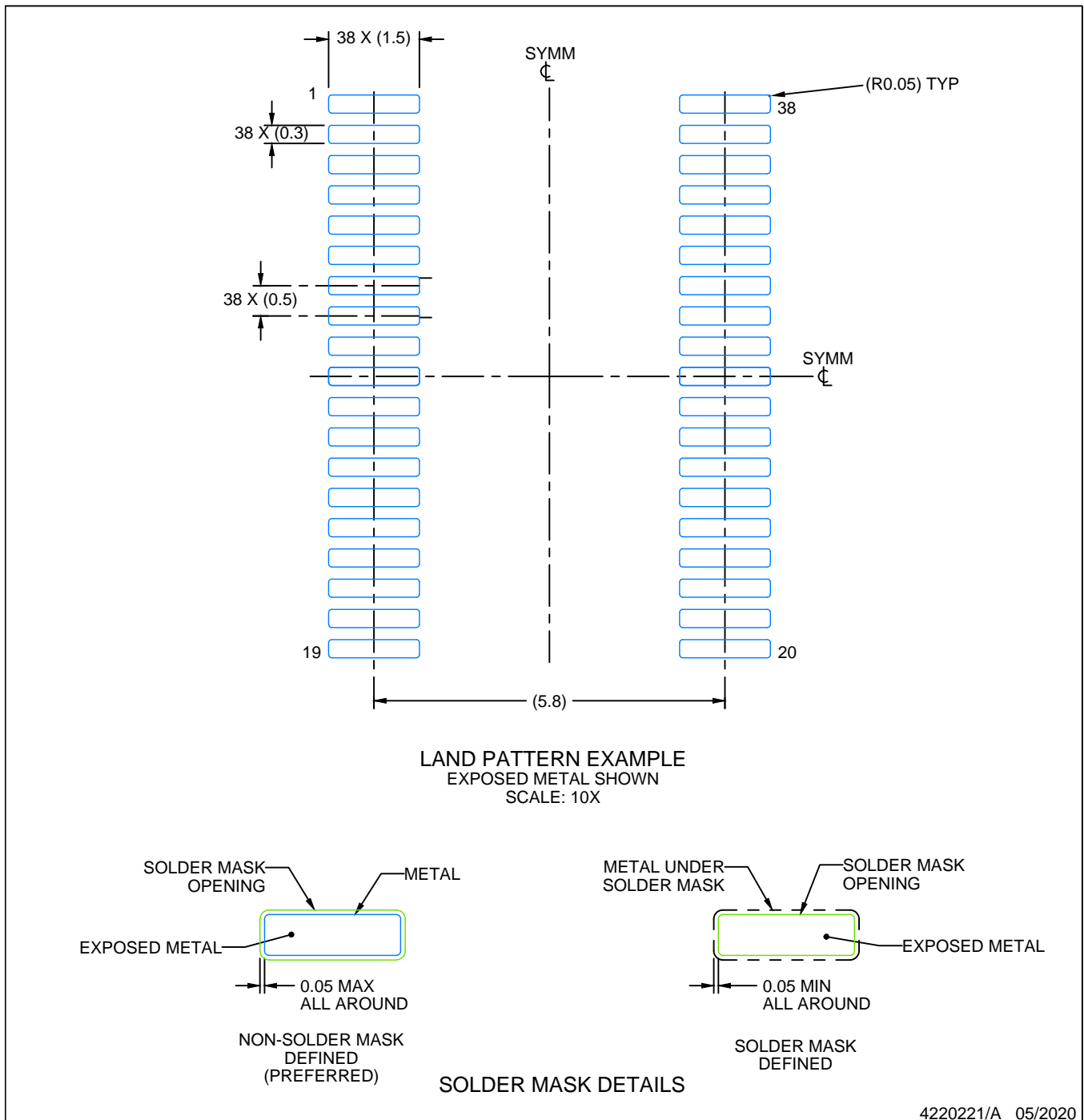

NOTES: (continued)

6. Publication IPC-7351 may have alternate designs.

7. Solder mask tolerances between and around signal pads can vary based on board fabrication site.

EXAMPLE STENCIL DESIGN

DBT0038A

TSSOP - 1.2 mm max height

SMALL OUTLINE PACKAGE

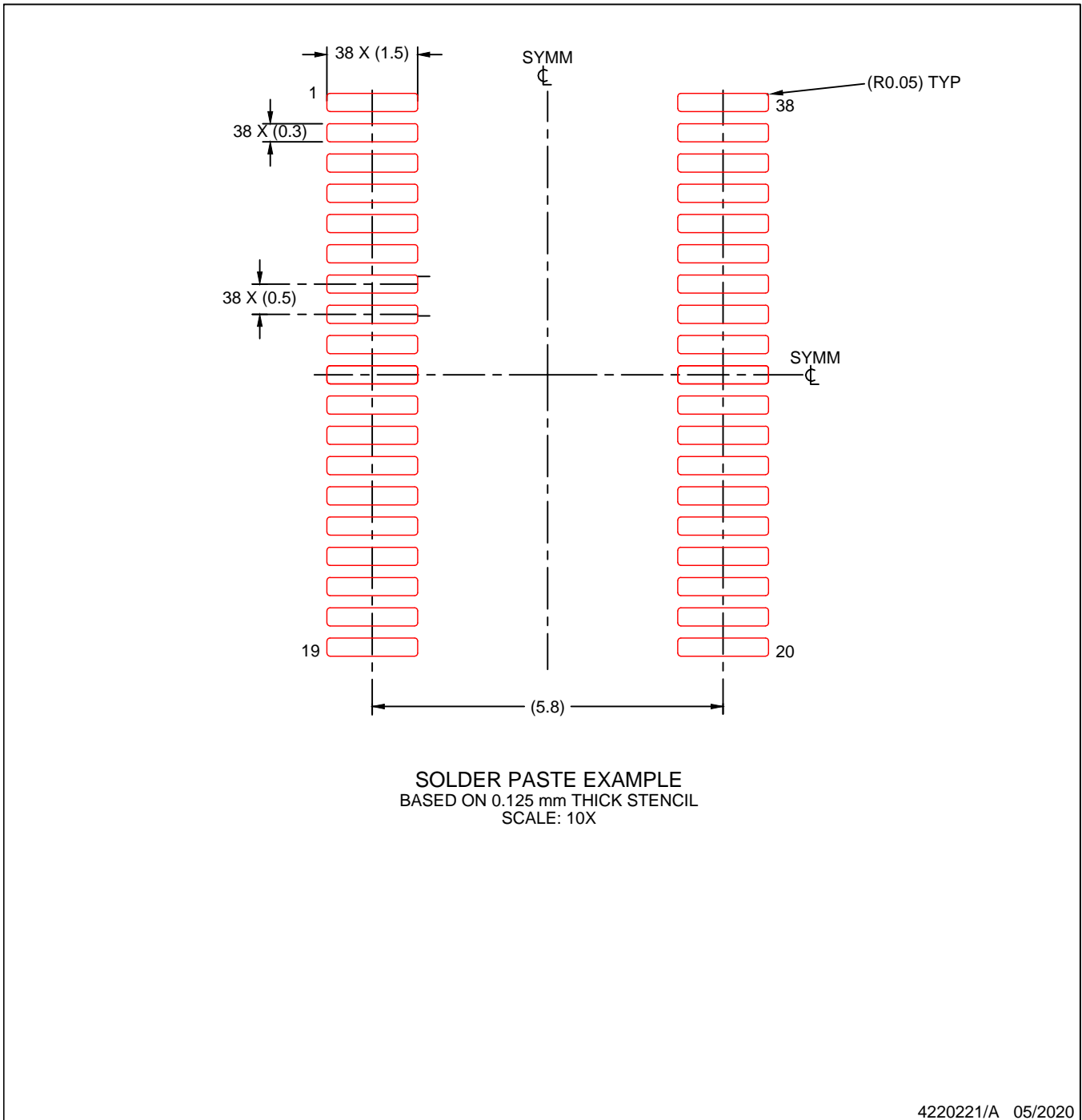

NOTES: (continued)

8. Laser cutting apertures with trapezoidal walls and rounded corners may offer better paste release. IPC-7525 may have alternate design recommendations.
9. Board assembly site may have different recommendations for stencil design.

IMPORTANT NOTICE AND DISCLAIMER

TI PROVIDES TECHNICAL AND RELIABILITY DATA (INCLUDING DATA SHEETS), DESIGN RESOURCES (INCLUDING REFERENCE DESIGNS), APPLICATION OR OTHER DESIGN ADVICE, WEB TOOLS, SAFETY INFORMATION, AND OTHER RESOURCES "AS IS" AND WITH ALL FAULTS, AND DISCLAIMS ALL WARRANTIES, EXPRESS AND IMPLIED, INCLUDING WITHOUT LIMITATION ANY IMPLIED WARRANTIES OF MERCHANTABILITY, FITNESS FOR A PARTICULAR PURPOSE OR NON-INFRINGEMENT OF THIRD PARTY INTELLECTUAL PROPERTY RIGHTS.

These resources are intended for skilled developers designing with TI products. You are solely responsible for (1) selecting the appropriate TI products for your application, (2) designing, validating and testing your application, and (3) ensuring your application meets applicable standards, and any other safety, security, regulatory or other requirements.

These resources are subject to change without notice. TI grants you permission to use these resources only for development of an application that uses the TI products described in the resource. Other reproduction and display of these resources is prohibited. No license is granted to any other TI intellectual property right or to any third party intellectual property right. TI disclaims responsibility for, and you will fully indemnify TI and its representatives against, any claims, damages, costs, losses, and liabilities arising out of your use of these resources.

TI's products are provided subject to [TI's Terms of Sale](#) or other applicable terms available either on [ti.com](https://www.ti.com) or provided in conjunction with such TI products. TI's provision of these resources does not expand or otherwise alter TI's applicable warranties or warranty disclaimers for TI products.

TI objects to and rejects any additional or different terms you may have proposed.

Mailing Address: Texas Instruments, Post Office Box 655303, Dallas, Texas 75265
Copyright © 2023, Texas Instruments Incorporated

Looking for pricing, stock, or lifecycle information?

Click below to explore more details on WIN SOURCE:

 [View BQ20Z80ADBT-V110](#) on WIN SOURCE

 [Texas Instruments](#) Information

Optimize Your Supply Chain with WIN SOURCE Solutions

-  Global Sourcing Solution
-  Obsolete Management
-  Cost Control Management
-  Shortage Management
-  Alternative Solution
-  Excess Inventory Management