



**THE DATASHEET OF
2500BL14M050T**



High Frequency Ceramic Solutions

2.45 GHz Balun, EIA 0603

P/N 2500BL14M050

Detail Specification: 7/15/2021

Page 1 of 4

General Specifications	
Part Number	2500BL14M050
Frequency (MHz)	2300 - 2700
Unbalanced Impedance (Ω)	50
Balanced Impedance (Ω)	50
Insertion Loss (dB)	1.2 max.
Return Loss (dB)	9.5 min.
Phase Difference (degree)	180 \pm 15
Amplitude Difference (dB)	1.5 max.
Power Capacity (W)	2 max. (CW)
Reel Quantity (pcs./reel)	4,000
Operating Temperature	-40 to +85°C
Recommended Storage Conditions and Period for unused Product on T&R	+5 to +35°C Humidity 45 - 75% RH 18 months max.

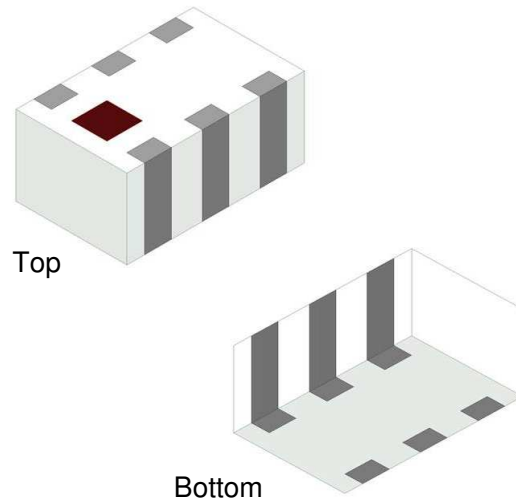

You can download measured s-parameters of this component at: <https://www.johansontechnology.com/baluns>

Part Number Explanation				
P/N Suffix	Packing Style	Bulk (loose pcs.)	Suffix = S	E.g. 2500BL14M050S
		T & R	Suffix = T	E.g. 2500BL14M050T
	Termination Style	100% Tin	Suffix = None	E.g. 2500BL14M050 (T or S)
	Evaluation Board	2500BL14M050-EB2SMA (3 female SMA connectors)		

Mechanical Dimensions		
	In	mm
L	0.063 \pm 0.004	1.60 \pm 0.10
W	0.031 \pm 0.004	0.80 \pm 0.10
T	0.024 \pm 0.004	0.60 \pm 0.10
a	0.008 \pm 0.004	0.20 \pm 0.10
b	0.008 +0.004/-0.008	0.20 +0.1/-0.15
c	0.006 \pm 0.004	0.15 \pm 0.10
g	0.012 \pm 0.004	0.30 \pm 0.10
p	0.020 \pm 0.004	0.50 \pm 0.10

Terminal Configuration	
1	Unbalanced Port
2	GND or DC feed + RF GND
3	Balanced Port
4	Balanced Port
5	GND
6	NC

Johanson Technology, Inc. reserves the right to make design changes without notice.
All sales are subject to Johanson Technology, Inc. terms and conditions.



<https://www.johansontechnology.com>

4001 Calle Tecate • Camarillo, CA 93012, USA • TEL +1.805.389.1166

Ver 3.0

2021 Johanson Technology, Inc. All Rights Reserved

High Frequency Ceramic Solutions

2.45 GHz Balun, EIA 0603

P/N 2500BL14M050

Detail Specification: 7/15/2021

Page 2 of 4

Layout and Mounting Considerations

Mount these devices with colored mark facing up.

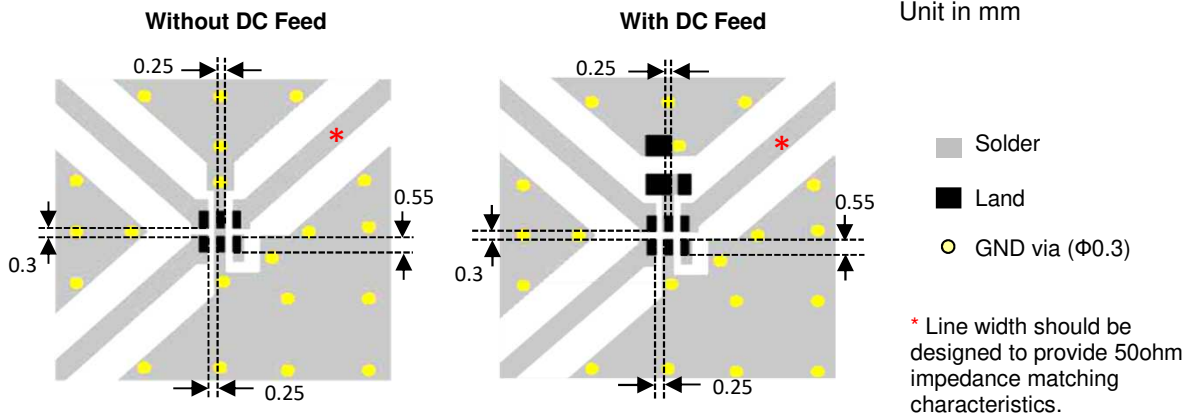

Need our help laying this out for you? Need the layout file?
Send us a message at: <https://www.johansontechnology.com/ask-a-question>

Measuring Diagram

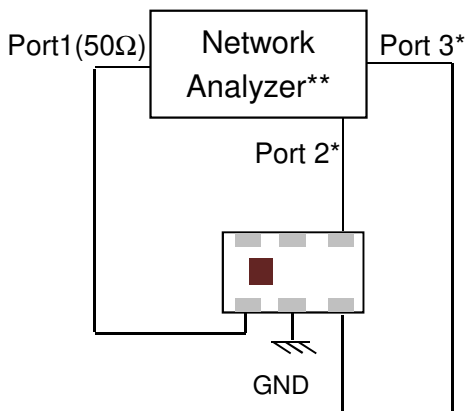

Port 1: Unbalanced Port
Ports 2 and 3: Balanced Port
 $IL = S_{ds21}$
 $RL = S_{ss11}$
 $Amp_balance = dB(S(2,1)/S(3,1))$
 $Phase_balance = Phase(S(2,1)/S(3,1))$

*Impedance for ports 2 and 3 = Balanced Impedance/2

**E5071B from Agilent

Johanson Technology, Inc. reserves the right to make design changes without notice.

All sales are subject to Johanson Technology, Inc. terms and conditions.



<https://www.johansontechnology.com>

4001 Calle Tecate • Camarillo, CA 93012, USA • TEL +1.805.389.1166

Ver 3.0

2021 Johanson Technology, Inc. All Rights Reserved

High Frequency Ceramic Solutions

2.45 GHz Balun, EIA 0603

P/N 2500BL14M050

Detail Specification: 7/15/2021

Page 3 of 4

Typical Electrical Characteristics (T=25°C)

Insertion and Return Loss

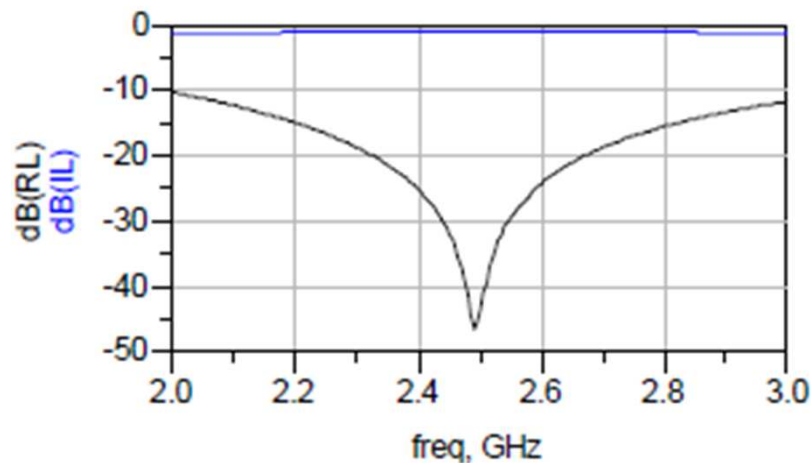

Amplitude and Phase Balance

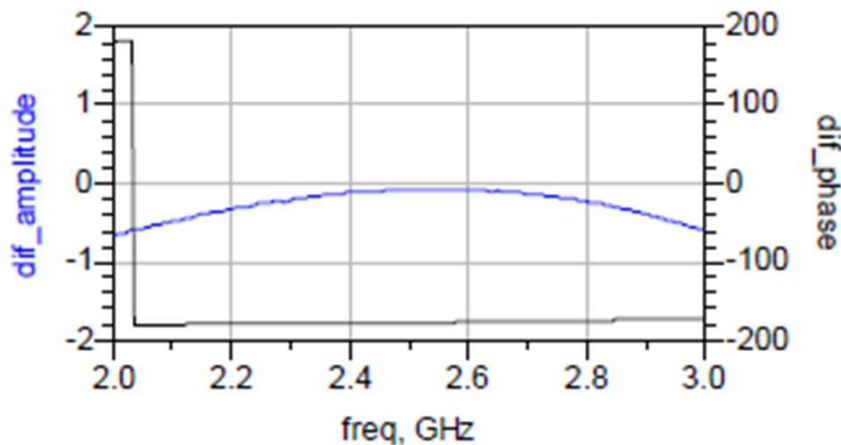

Would you like the s-parameter files? Please contact us at: <https://www.johansontechnology.com/ask-a-question>

Johanson Technology, Inc. reserves the right to make design changes without notice.

All sales are subject to Johanson Technology, Inc. terms and conditions.



<https://www.johansontechnology.com>

4001 Calle Tecate • Camarillo, CA 93012, USA • TEL +1.805.389.1166

Ver 3.0

2021 Johanson Technology, Inc. All Rights Reserved

High Frequency Ceramic Solutions

2.45 GHz Balun, EIA 0603

P/N 2500BL14M050

Detail Specification: 7/15/2021

Page 4 of 4

More Filter-Balun info at:

<https://www.johansontechnology.com/baluns>

Packaging information

<https://www.johansontechnology.com/tape-reel-packaging>

Soldering Information

<https://www.johansontechnology.com/ipcsoldering-profile>

MSL Info

<https://www.johansontechnology.com/msl-rating>

Recommended Storage Condition and Max Shelf Life

<https://www.johansontechnology.com/recommended-storage-conditions>

RoHS Compliance

<https://www.johansontechnology.com/rohs-compliance>

Layout review services

<https://www.johansontechnology.com/ask-a-question>

Antenna layout review, tuning, and characterization services

<https://www.johansontechnology.com/pc-antenna-services>

Johanson Technology, Inc. reserves the right to make design changes without notice.

All sales are subject to Johanson Technology, Inc. terms and conditions.



<https://www.johansontechnology.com>

4001 Calle Tecate • Camarillo, CA 93012, USA • TEL +1.805.389.1166

Ver 3.0

2021 Johanson Technology, Inc. All Rights Reserved

Looking for pricing, stock, or lifecycle information?

Click below to explore more details on WIN SOURCE:

 [View 2500BL14M050T on WIN SOURCE](#)

 [Johanson Technology Inc. Information](#)

Optimize Your Supply Chain with WIN SOURCE Solutions

-  Global Sourcing Solution
-  Obsolete Management
-  Cost Control Management
-  Shortage Management
-  Alternative Solution
-  Excess Inventory Management