

Low-Cost NiCd/NiMH Gas Gauge IC

Features

- Accurate measurement of available capacity in NiCd or NiMH batteries
- Low-cost battery management solution for pack integration
 - As little as ½ square inch of PCB for complete circuit
 - Low operating current (120µA typical)
 - Less than 100nA of data retention current
- High-speed (5kb/s) single-wire communication interface (HDQ bus) for critical battery parameters
- Communication with an external charge controller such as the bq2004
- Direct drive of remaining capacity LEDs
- Automatic rate and temperature compensation of measurements
- 16-pin narrow SOIC

General Description

The bq2014H NiCd/NiMH Gas Gauge IC is intended for battery-pack or in-system installation to maintain an accurate record of available battery capacity. The IC monitors a voltage drop across a sense resistor connected in series between the negative battery terminal and ground to determine charge and discharge activity of the battery. Compensations for battery temperature, self-discharge, and rate of discharge are applied to the charge counter to provide available capacity information across a wide range of operating conditions. Battery capacity is automatically recalibrated, or “learned,” in the course of a discharge cycle from full to empty.

Nominal available capacity may be directly indicated using a five-segment LED display. The bq2014H also supports a simple single-line

bidirectional serial link to an external processor (common ground). The 5kb/s HDQ bus interface reduces communications overhead in the external microcontroller.

Internal registers include available capacity and energy, temperature, voltage and current, and battery status. The external processor may also overwrite some of the bq2014H gas gauge data registers.

The bq2014H can operate from the batteries in the pack. The REF output and an external transistor allow a simple, inexpensive voltage regulator to supply power to the circuit from the cells.

Pin Connections

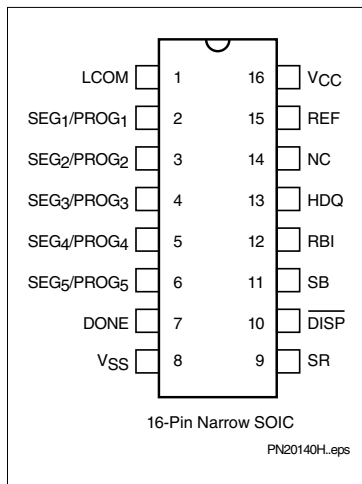

Pin Names

LCOM	LED common output	V _{SS}	System ground
SEG ₁ /PROG ₁	LED segment 1/ program 1 input	SR	Sense resistor input
SEG ₂ /PROG ₂	LED segment 2/ program 2 input	$\overline{\text{DISP}}$	Display control input
SEG ₃ /PROG ₃	LED segment 3/ program 3 input	SB	Battery sense input
SEG ₄ /PROG ₄	LED segment 4/ program 4 input	RBI	Register backup input
SEG ₅ /PROG ₅	LED segment 5/ program 5 input	HDQ	Serial communications input/output
DONE	Charge complete input	NC	No connect
		REF	Voltage reference output
		V _{CC}	Supply voltage

bq2014H

Pin Descriptions

LCOM **LED common output**

Open-drain output that switches V_{CC} to source current for the LEDs. The switch is off during initialization to allow reading of the soft pull-up or pull-down program resistors. LCOM is also high impedance when the display is off.

SEG₁–SEG₅ **LED display segment outputs (dual function with PROG₁–PROG₅)**

Outputs that each may activate an LED to sink the current sourced from LCOM.

PROG₁–PROG₂ **Programmed full count selection inputs (dual function with SEG₁–SEG₂)**

Three-level input pins that define the programmed full count (PFC) thresholds described in Table 2.

PROG₃–PROG₄ **Power gauge scale selection inputs (dual function with SEG₃–SEG₄)**

Three-level input pins that define the scale factor described in Table 2.

PROG₅ **Self-discharge rate selection (dual function with SEG₅)**

Three-level input pin that defines the self-discharge and battery-compensation factors as shown in Table 1.

DONE **Charge complete input**

Communicates the status of an external charge-controller such as the bq2004 Fast-Charge IC to the bq2014H. Note: This pin must be pulled down to V_{SS} using a 200k Ω resistor.

VSS **Ground**

SR **Sense resistor input**

The voltage drop (V_{SR}) across the sense resistor R_S is monitored and integrated over time to interpret charge and discharge activity. $V_{SR} < V_{SS}$ indicates discharge, and $V_{SR} > V_{SS}$ indicates charge. The effective voltage drop, V_{SRO} , as seen by the bq2014H is $V_{SR} + V_{OS}$.

\overline{DISP}

Display control input

\overline{DISP} high disables the LED display. \overline{DISP} tied to V_{CC} allows PROG_x to connect directly to V_{CC} or V_{SS} instead of through a pull-up or pull-down resistor. \overline{DISP} floating allows the LED display to be active during charge. \overline{DISP} low activates the display. See Table 1.

SB

Secondary battery input

Monitors the battery cell-voltage potential through a high-impedance resistive divider network for end-of-discharge voltage (EDV) thresholds and for battery-removed detection.

RBI

Register backup input

Provides backup potential to the bq2014H registers while $V_{CC} \leq 3V$. A storage capacitor or a battery can be connected to RBI.

HDQ

Serial communication input/output

This is the open-drain bidirectional communications port.

NC

No connect

REF

Voltage reference output

REF provides a voltage reference output for an optional microregulator.

VCC

Supply voltage input

Functional Description

General Operation

The bq2014H determines battery capacity by monitoring the amount of current input to or removed from a rechargeable battery. The bq2014H measures discharge and charge currents, measures battery voltage, estimates self-discharge, monitors the battery for low battery-voltage thresholds, and compensates for temperature and charge/discharge rate. Current measurement is made by monitoring the voltage across a small-value series sense resistor between the negative battery terminal and ground. The bq2014H compensates the nominal available capacity register for discharge rate and temperature and reports the compensated available capacity. The bq2014H uses the compensated available

capacity to drive the LED display. In addition, the bq2014H estimates the available energy using the average battery voltage during the discharge cycle and remaining compensated available capacity.

Figure 1 shows a typical battery pack application of the bq2014H using the LED display capability as a charge-state indicator. The bq2014H is configured to display capacity in relative display mode. The relative display mode uses the last measured discharge capacity of the battery as the battery “full” reference. A push-button feature is available for momentarily enabling the LED display.

The bq2014H monitors the charge and discharge currents as a voltage across a sense resistor. (See R_S in Figure 1.) A filter between the negative battery terminal and the SR pin is required.

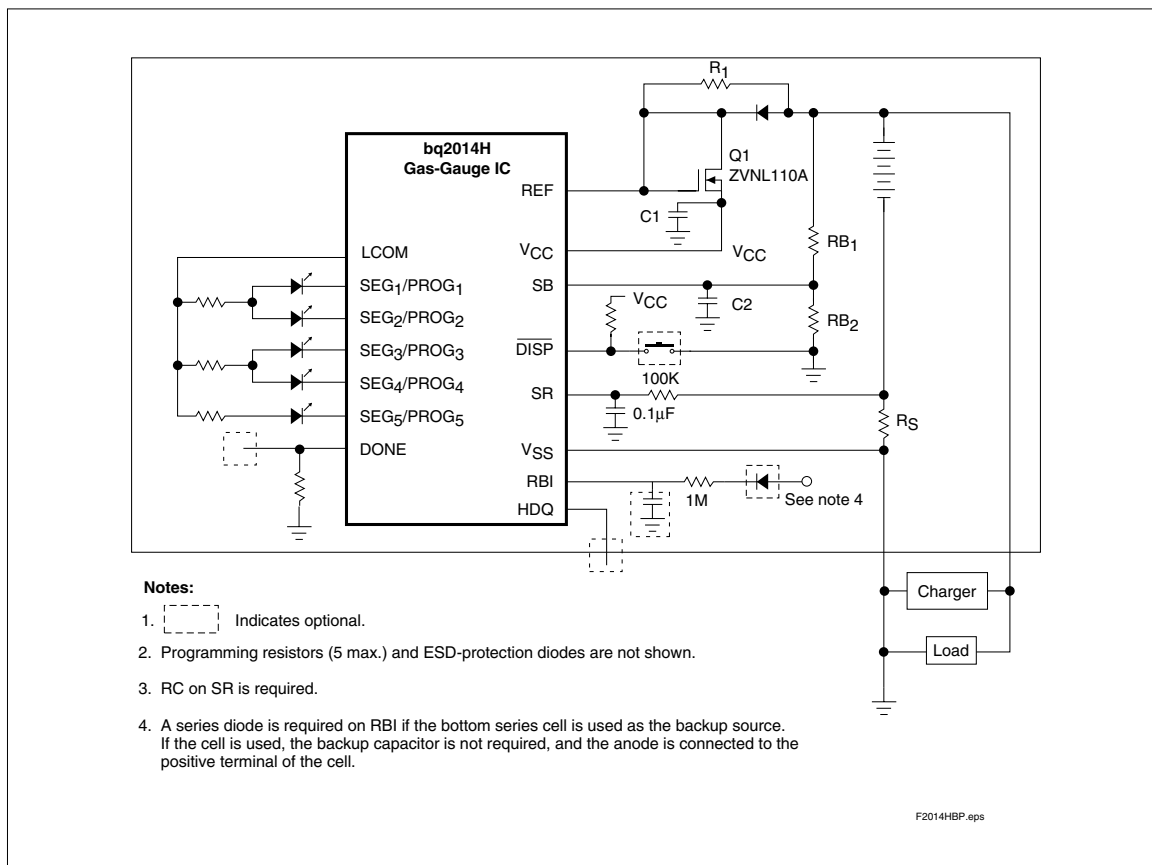

Figure 1. Battery Pack Application Diagram—LED Display

bq2014H

Voltage Thresholds

In conjunction with monitoring V_{SR} for charge/discharge currents, the bq2014H monitors the battery potential through the SB pin for the end-of-discharge voltage (EDV) thresholds.

The EDV threshold levels are used to determine when the battery has reached an “empty” state.

The EDV thresholds for the bq2014H are programmable with the default values fixed as follows:

$$\text{EDV1 (first)} = 0.76\text{V}$$

$$\text{EDVF (final)} = \text{EDV1} - 0.025\text{V} = 0.735\text{V}$$

The battery voltage divider (RB1 and RB2 in Figure 1) is used to scale these values to the desired threshold.

If V_{SB} is below either of the two EDV thresholds, the associated flag is latched and remains latched, independent of V_{SB} , until the next valid charge.

EDV monitoring is disabled if the discharge rate is greater than 2C (OVL D Flag = 1) and resumes $\frac{1}{2}$ second after the rate falls below 2C. The V_{SB} value is available over the serial port.

RBI Input

The RBI input pin is used with a storage capacitor or external supply to provide backup potential to the internal bq2014H registers when V_{CC} drops below 3.0V. V_{CC} is output on RBI when V_{CC} is above 3.0V. If using an external supply (such as the bottom series cell) as the backup source, an external diode is required for isolation.

Reset

The bq2014H can be reset by removing V_{CC} and grounding the RBI pin for 15 seconds or by commands over the serial port. The serial port reset command sequence requires writing 00h to register PFFC (address = 1Eh) and then writing 00h to register LMD (address = 05h).

Temperature

The bq2014H internally determines the temperature in 10°C steps centered from approximately -35°C to +85°C. The temperature steps are used to adapt charge and discharge rate compensations, self-discharge counting, and available charge display translation.

The temperature range is available over the serial port in 10°C increments, as shown in the following table

TMP (hex)	Temperature Range
0x	< -30°C
1x	-30°C to -20°C
2x	-20°C to -10°C
3x	-10°C to 0°C
4x	0°C to 10°C
5x	10°C to 20°C
6x	20°C to 30°C
7x	30°C to 40°C
8x	40°C to 50°C
9x	50°C to 60°C
Ax	60°C to 70°C
Bx	70°C to 80°C
Cx	> 80°C

Layout Considerations

The bq2014H measures the voltage differential between the SR and V_{SS} pins. V_{OS} (the offset voltage at the SR pin) is greatly affected by PC board layout. For optimal results, the PC board layout should follow the strict rule of a single-point ground return. Sharing high-current ground with small-signal ground causes undesirable noise on the small-signal nodes. Additionally:

- The capacitors (C1 and C2) should be placed as close as possible to the V_{CC} and SB pins, respectively, and their paths to V_{SS} should be as short as possible. A high-quality ceramic capacitor of 0.1 μ F is recommended for V_{CC} .
- The sense-resistor capacitor should be placed as close as possible to the SR pin.
- The sense resistor (R_S) should be as close as possible to the bq2014H.

Gas Gauge Operation

The operational overview diagram in Figure 2 illustrates the operation of the bq2014H. The bq2014H accumulates a measure of charge and discharge currents, as well as an estimation of self-discharge. The accumulated charge and discharge currents are adjusted for temperature and rate to provide the indication of compensated available capacity to the host system or user.

The main counter, Nominal Available Capacity (NAC), represents the available battery capacity at any given time. Battery charging increments the NAC register, while battery discharging and self-discharge decrement the NAC register and increment the DCR (Discharge Count Register).

The Discharge Count Register is used to update the Last Measured Discharge (LMD) register only if a complete battery discharge from full to empty occurs without any partial battery charges. Therefore, the bq2014H adapts its capacity determination based on the actual conditions of discharge.

The battery's initial capacity equals the Programmed Full Count (PFC) shown in Table 2. Until LMD is updated, NAC counts up to but not beyond this threshold during subsequent charges. This approach allows the gas gauge to be charger-independent and compatible with any type of charge regime.

1. Last Measured Discharge (LMD) or learned battery capacity:

LMD is the last measured discharge capacity of the battery. On initialization (application of V_{CC} or battery replacement), $LMD = PFC$. During subsequent discharges, the LMD is updated with the latest measured capacity in the Discharge Count Register representing a discharge from full to below EDV1. A qualified discharge is necessary for a capacity transfer from the DCR to the LMD register. The LMD also serves as the 100% reference threshold used by the relative display mode.

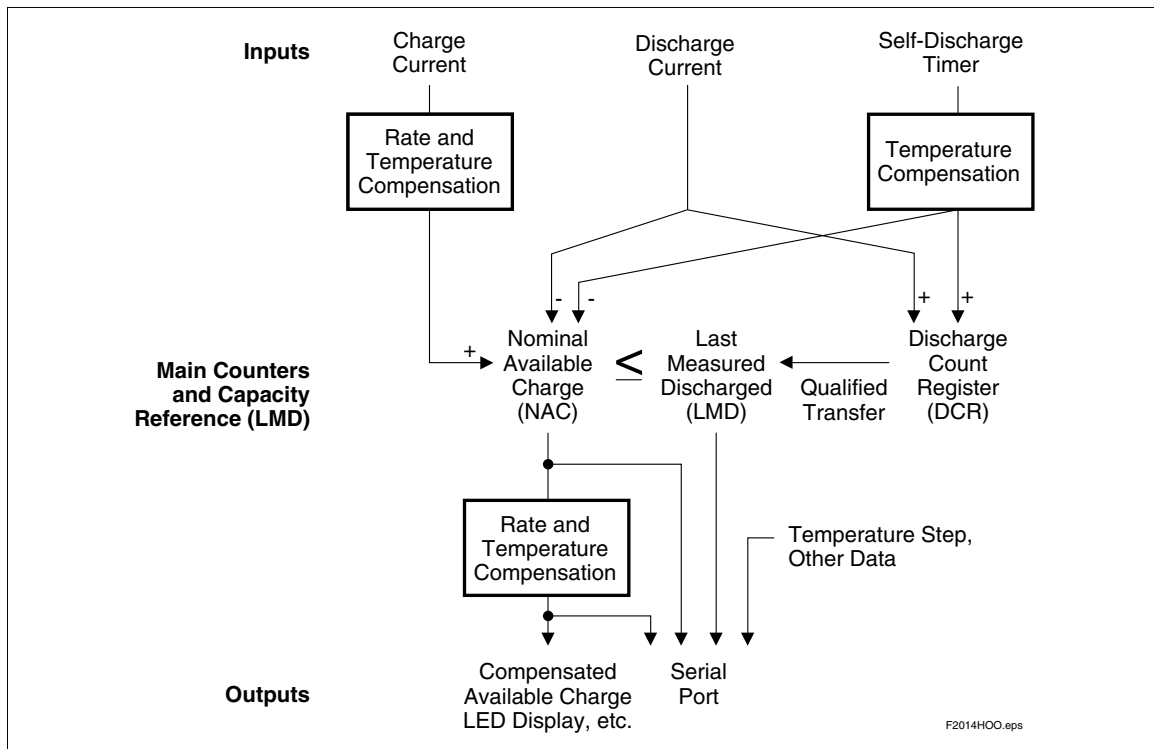

Figure 2. Operational Overview

bq2014H

2. Programmed Full Count (PFC) or initial battery capacity:

The initial LMD and gas gauge rate values are programmed by using PROG₁–PROG₄. The bq2014H is configured for a given application by selecting a PFC value from Table 2. The correct PFC may be determined by multiplying the rated battery capacity in mAh by the sense resistor value:

$$\text{Battery capacity (mAh)} * \text{sense resistor } (\Omega) = \text{PFC (mVh)}$$

Selecting a PFC slightly less than the rated capacity provides a conservative capacity reference until the bq2014H “learns” a new capacity reference.

Example: Selecting a PFC Value

Given:

- Sense resistor = 0.05Ω
- Number of cells = 10
- Capacity = 3500mAh, NiMH
- Current range = 50mA to 1A
- Relative display mode
- Self-discharge = $\frac{NAC}{47}$ per day @ 25°C
- Voltage drop over sense resistor = 2.5mV to 50mV
- Nominal discharge voltage = 1.2V

Therefore:

$$3500\text{mAh} * 0.05\Omega = 175\text{mVh}$$

Table 1. Self-Discharge and Capacity Compensation

Pin Connection	PROG ₅ Self-Discharge Rate	DISP Display State
H	Disabled	LEDs disabled
Z	$\frac{NAC}{64}$	LEDs on when charging
L	$\frac{NAC}{47}$	LEDs on for 4s

Table 2. bq2014H Programmed Full Count mVh, V_{SR} Gain Selections

PROG _x		Pro-grammed Full Count (PFC)	PROG ₄ = L			PROG ₄ = Z or H			Units
1	2		PROG ₃ = H	PROG ₃ = Z	PROG ₃ = L	PROG ₃ = H	PROG ₃ = Z	PROG ₃ = L	
-	-	-	SCALE = 1/80	SCALE = 1/160	SCALE = 1/320	SCALE = 1/640	SCALE = 1/1280	SCALE = 1/2560	mVh/count
H	H	49152	614	307	154	76.8	38.4	19.2	mVh
H	Z	45056	563	282	141	70.4	35.2	17.6	mVh
H	L	40960	512	256	128	64.0	32.0	16.0	mVh
Z	H	36864	461	230	115	57.6	28.8	14.4	mVh
Z	Z	33792	422	211	106	53.0	26.4	13.2	mVh
Z	L	30720	384	192	96.0	48.0	24.0	12.0	mVh
L	H	27648	346	173	86.4	43.2	21.6	10.8	mVh
L	Z	25600	320	160	80.0	40.0	20.0	10.0	mVh
L	L	22528	282	141	70.4	35.2	17.6	8.8	mVh
V _{SR} equivalent to 2 counts/s (nom.)			90	45	22.5	11.25	5.6	2.8	mV

Select:

PFC = 27648 counts or 173mVh
 PROG₁ = low
 PROG₂ = high
 PROG₃ = float
 PROG₄ = low
 PROG₅ = low

The initial full battery capacity is 173mVh (3460mAh) until the bq2014H “learns” a new capacity with a qualified discharge from full to EDV1.

3. Nominal Available Capacity (NAC):

NAC counts up during charge to a maximum value of LMD and down during discharge and self-discharge to 0. NAC is reset to 0 on initialization and on the first valid charge following discharge to EDV1. To prevent overstatement of charge during periods of overcharge, NAC stops incrementing when NAC = LMD or $0.94 * LMD$ if $T < 0^{\circ}C$.

4. Discharge Count Register (DCR):

The DCR counts up during discharge independent of NAC and could continue increasing after NAC has decremented to 0. Prior to NAC = 0 (empty battery), both discharge and self-discharge increment the DCR. After NAC = 0, only discharge increments the DCR. The DCR resets to 0 when $NAC \geq 0.94 * LMD$ and a discharge is detected. The DCR does not roll over but stops counting when it reaches FFh.

The DCR value becomes the new LMD value on the first charge after a valid discharge to VEDV1 if all the following conditions are met:

- No valid charge initiations (charges greater than 2 NAC updates where $V_{SRO} > V_{SRQ}$) occurred during the period between $NAC \geq 0.94 * LMD$ and EDV1.
- The self-discharge is less than 6.25% of NAC.
- The temperature is $\geq 0^{\circ}C$ when the EDV1 level is reached during discharge.
- The discharge begins when $NAC \geq 0.94 * LMD$.
- VDQ is set.

The valid discharge flag (VDQ) indicates whether the present discharge is valid for LMD update. If the DCR update value is less than $0.94 * LMD$, LMD will only be modified by $0.94 * LMD$. This prevents invalid DCR values from corrupting LMD.

5. Scaled Available Energy (SAE):

SAE is useful in determining the available energy within the battery, and may provide a more useful

capacity reference in battery chemistries with sloped voltage profiles during discharge. SAE may be converted to an mWh value using the following formula:

$$E(\text{mWh}) = (\text{SAEH} * 256 + \text{SAEL}) * \frac{1.2 * \text{SCALE} * (\text{RB1} + \text{RB2})}{\text{RS} * \text{RB2}}$$

where RB1 , RB2 , and RS are resistor values in ohms, as shown in Figure 1. SCALE is the selected scale from Table 2.

6. Compensated Available Capacity (CACT)

CACT counts similarly to NAC, but contains the available capacity compensated for discharge rate and temperature.

Charge Counting

Charge activity is detected based on a positive voltage on the SR input. If charge activity is detected, the bq2014H increments NAC at a rate proportional to V_{SR} and, if enabled, activates the LED display.

The bq2014H counts charge activity when the voltage at the SR input (V_{SRO}) exceeds the minimum charge threshold (V_{SRQ}). A valid charge is detected when NAC has been updated twice without discharging or reaching the digital magnitude filter time-out. Once a valid charge is detected, charge counting continues until V_{SR} , including offset, falls below V_{SRQ} .

Discharge Counting

Discharge activity is indicated by a negative voltage on the SR input. All discharge counts where V_{SRO} is less than the minimum discharge threshold (V_{SRD}) cause the NAC register to decrement and the DCR to increment.

Self-Discharge Counting

The bq2014H continuously decrements NAC and increments DCR for self-discharge on the basis of time and temperature.

Charge/Discharge Current

The bq2014H current-scale registers, V_{SRH} and V_{SRL} , can be used to determine the battery charge or discharge current. See the Current Scale Register description for details.

bq2014H

Count Compensations

Charge Compensation

Two charge efficiency compensation factors are used for trickle and fast charge. Trickle charge is defined as a rate of charge $< C/3$. The compensation defaults to the fast-charge factor until the actual charge rate is determined.

Temperature adapts the charge rate compensation factors over two ranges between nominal and hot temperatures. The compensation factors are shown below.

Charge Temperature	Trickle-Charge Compensation	Fast-Charge Compensation
$< 40^{\circ}\text{C}$	0.81	0.94
$> 40^{\circ}\text{C}$	0.75	0.88

Compensated Available Capacity

NAC is adjusted for rate of discharge and temperature to derive the CACD and CACT values.

Corrections for the rate of discharge are made by adjusting an internal discharge compensation factor. The discharge factor is based on the discharge rate. This compensation is applied to NAC to derive the value in the CACD register.

The compensation factors during discharge are:

Approximate Discharge Rate	Rate Efficiency Factor
$< 2\text{C}$	100%
$> 2\text{C}$	95%

Temperature compensation during discharge also takes place. At lower temperatures, the compensation factor increases by 0.05 for each 10°C temperature range below 10°C . This compensation is applied to CACD to derive the value in the CACT register. The temperature compensation factor follows the equation

$$\text{Temperature Efficiency Factor} = 1.00 - (0.05 * N)$$

where N = number of 10°C steps below 10°C .

For example,

$T > 10^{\circ}\text{C}$: Nominal compensation, $N = 0$

$0^{\circ}\text{C} < T < 10^{\circ}\text{C}$: $N = 1$ (temperature efficiency = 95%)

$-10^{\circ}\text{C} < T < 0^{\circ}\text{C}$: $N = 2$ (temperature efficiency = 90%)

$-20^{\circ}\text{C} < T < -10^{\circ}\text{C}$: $N = 3$ (temperature efficiency = 85%)

$-20^{\circ}\text{C} < T < -30^{\circ}\text{C}$: $N = 4$ (temperature efficiency = 80%)

Self-Discharge Compensation

The self-discharge compensation is programmed for a nominal rate of $\frac{1}{64} * \text{NAC}$ per day, $\frac{1}{47} * \text{NAC}$ per day, or disabled. This is the rate for a battery within the 20°C – 30°C temperature range (TMPGG = 6x). This rate varies across 8 ranges from $<10^{\circ}\text{C}$ to $>70^{\circ}\text{C}$, doubling

Table 3. Self-Discharge Compensation

Temperature Step	Typical Rate	
	PROG5 = Z	PROG5 = L
$< 10^{\circ}\text{C}$	$\text{NAC}/_{256}$	$\text{NAC}/_{188}$
$10\text{--}20^{\circ}\text{C}$	$\text{NAC}/_{128}$	$\text{NAC}/_{94}$
$20\text{--}30^{\circ}\text{C}$	$\text{NAC}/_{64}$	$\text{NAC}/_{47}$
$30\text{--}40^{\circ}\text{C}$	$\text{NAC}/_{32}$	$\text{NAC}/_{23.5}$
$40\text{--}50^{\circ}\text{C}$	$\text{NAC}/_{16}$	$\text{NAC}/_{11.8}$
$50\text{--}60^{\circ}\text{C}$	$\text{NAC}/_{8}$	$\text{NAC}/_{5.88}$
$60\text{--}70^{\circ}\text{C}$	$\text{NAC}/_{4}$	$\text{NAC}/_{2.94}$
$> 70^{\circ}\text{C}$	$\text{NAC}/_{2}$	$\text{NAC}/_{1.47}$

with each higher temperature step (10°C). See Table 3.

Digital Magnitude Filter

The bq2014H has a digital filter to eliminate charge and discharge counting below a set threshold. The threshold for both VSRD and VSRQ is $250\mu\text{V}$.

Table 6. bq2014H Current-Sensing Errors

Symbol	Parameter	Typical	Maximum	Units	Notes
INL	Integrated non-linearity error	± 2	± 4	%	Add 0.1% per °C above or below 25°C and 1% per volt above or below 4.25V.
INR	Integrated non-repeatability error	± 1	± 2	%	Measurement repeatability given similar operating conditions.

Error Summary

Capacity Inaccurate

The LMD is susceptible to error on initialization or if no updates occur. On initialization, the LMD value includes the error between the programmed full capacity and the actual capacity. This error is present until a valid discharge occurs and LMD is updated. (See the DCR description.) The other cause of LMD error is battery wear-out. As the battery ages, the measured capacity must be adjusted to account for changes in actual battery capacity.

A Capacity Inaccurate counter (CPI) is maintained and incremented each time a valid charge occurs (qualified by NAC; see the CPI register description). It is reset whenever LMD is updated from the DCR. The counter does not wrap around but stops counting at 255. The capacity inaccurate flag (CI) is set if LMD has not been updated following 64 valid charges.

Current-Sensing Error

Table 6 shows the non-linearity and non-repeatability errors associated with the bq2014H current sensing.

Table 7 illustrates the current-sensing error as a function of V_{OS} . A digital filter prevents charge and discharge counts to the NAC register when V_{SRO} is between V_{SRQ} and V_{SRD} .

Table 7. V_{OS} -Related Current Sense Error (Current = 1A)

V_{OS} (μ V)	Sense Resistor			
	20	50	100	m Ω
50	0.25	0.10	0.05	%
100	0.50	0.20	0.10	%
150	0.75	0.30	0.15	%
180	0.90	0.36	0.18	%

Done Input

A charge-control IC or a microcontroller uses the DONE input to communicate charge status to the bq2014H. When the DONE input is asserted high on charge completion, the bq2014H sets $NAC = LMD$ and $VDQ = 1$. The DONE input should be maintained high as long as the charge controller or microcontroller keeps the batteries full; otherwise, the pin should be held low.

Communicating with the bq2014H

The bq2014H includes a simple single-pin (HDQ plus return) serial data interface. A host processor uses the interface to access various bq2014H registers. Battery characteristics may be easily monitored by adding a single contact to the battery pack. The open-drain HDQ pin on the bq2014H should be pulled up by the host system, or may be left floating if the serial interface is not used.

The interface uses a command-based protocol, in which the host processor sends a command byte to the bq2014H. The command directs the bq2014H to either store the next eight bits of data received to a register specified by the command byte or output the eight bits of data specified by the command byte. (See Figure 4.)

The communication protocol is asynchronous return-to-one. Command and data bytes consist of a stream of eight bits that have a maximum transmission rate of 5K bits/sec. The least-significant bit of a command or data byte is transmitted first. The protocol is simple enough that it can be implemented by most host processors using either polled or interrupt processing. Data input from the bq2014H may be sampled using the pulse-width capture timers available on some microcontrollers.

If a communication error occurs (e.g., $t_{CYCB} > 250\mu$ s), the bq2014H should be sent a BREAK to reinitiate the serial interface. A BREAK is detected when the HDQ pin is driven to a logic-low state for a time, t_B or greater. The HDQ pin should then be returned to its normal ready-high logic state for a time, t_{BR} . The bq2014H is now ready to receive a command from the host processor.

bq2014H

The return-to-one data bit frame consists of three distinct sections:

1. The first section is used to start the transmission by either the host or the bq2014H taking the HDQ pin to a logic-low state for a period, $t_{STRH,B}$.
2. The next section is the actual data transmission, where the data should be valid by a period, $t_{DSU,B}$, after the negative edge used to start communication. The data should be held for a period, $t_{DH,DV}$, to allow the host or bq2014H to sample the data bit.
3. The final section is used to stop the transmission by returning the HDQ pin to a logic-high state by at least a period, $t_{SSU,B}$, after the negative edge used to start communication. The final logic-high state should be until a period $t_{CYCH,B}$, to allow time to ensure that the bit transmission was stopped properly. The timings for data and break communication are given in the serial communication timing specification and illustration sections.

Communication with the bq2014H is always performed with the bit transmitted first. Figure 5 shows an example of a communication sequence to read the bq2014H NACH register.

bq2014H Command Code and Registers

The bq2014H status registers are listed in Table 8 and described below. All registers are Read/Write in the bq2014H. **Caution: When writing to bq2014H registers ensure that proper data are written. A write-verify read is recommended.**

Command Code

The bq2014H latches the command code when eight valid command bits have been received by the bq2014H. The command code contains two fields:

- W/\bar{R} bit
- Command address

The W/\bar{R} bit of the command code is used to select whether the received command is for a read or a write function:

The W/\bar{R} values are

Command Code Bits							
7	6	5	4	3	2	1	0
W/\bar{R}	-	-	-	-	-	-	-

where W/\bar{R} is

- 0 The bq2014H outputs the requested register contents specified by the address portion of command code.
- 1 The following eight bits should be written to the register specified by the address portion of command code.

The lower 7-bit field of the command code contains the address portion of the register to be accessed:

Command Code Bits							
7	6	5	4	3	2	1	0
-	AD6	AD5	AD4	AD3	AD2	AD1	AD0 (LSB)

Primary Status Flags Register (FLGS1)

The FLGS1 register (address = 01h) contains the primary bq2014H flags.

The **charge status** flag (CHGS) is asserted when a valid charge rate is detected. Charge rate is deemed valid when $VSRO > VSRQ$. A $VSRO$ of less than $VSRQ$ or discharge activity clears CHGS.

The CHGS values are

FLGS1 Bits							
7	6	5	4	3	2	1	0
CHGS	-	-	-	-	-	-	-

where CHGS is

- 0 Either discharge activity detected or $VSRO \leq VSRQ$
- 1 $VSRO > VSRQ$

The **battery replaced** flag (BRP) is asserted whenever the bq2014H is reset either by application of VCC or by a serial port command. BRP is reset when either a valid charge action increments NAC to be equal to LMD, or a valid charge action is detected after the EDV1 flag is asserted. BRP = 1 signifies that the device has been reset.

The BRP values are

FLGS1 Bits							
7	6	5	4	3	2	1	0
-	BRP	-	-	-	-	-	-

where BRP is

- 0 Battery is charged until $NAC = LMD$ or discharged until the EDV1 flag is asserted
- 1 bq2014H is reset

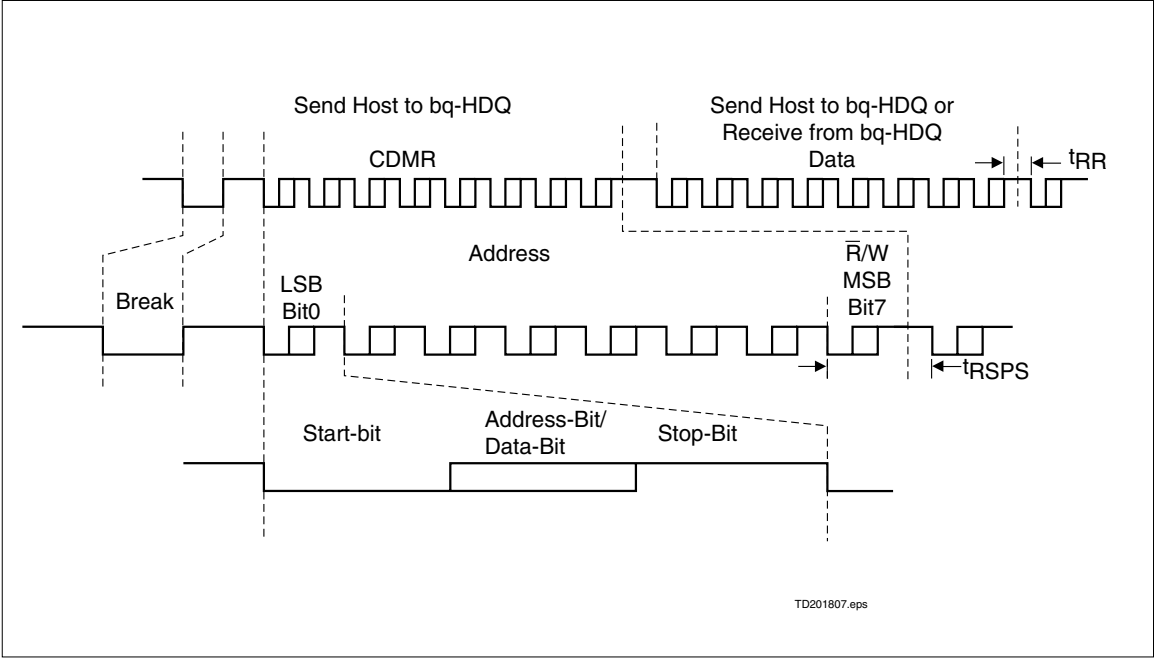

Figure 4. bq2014H Communication Example

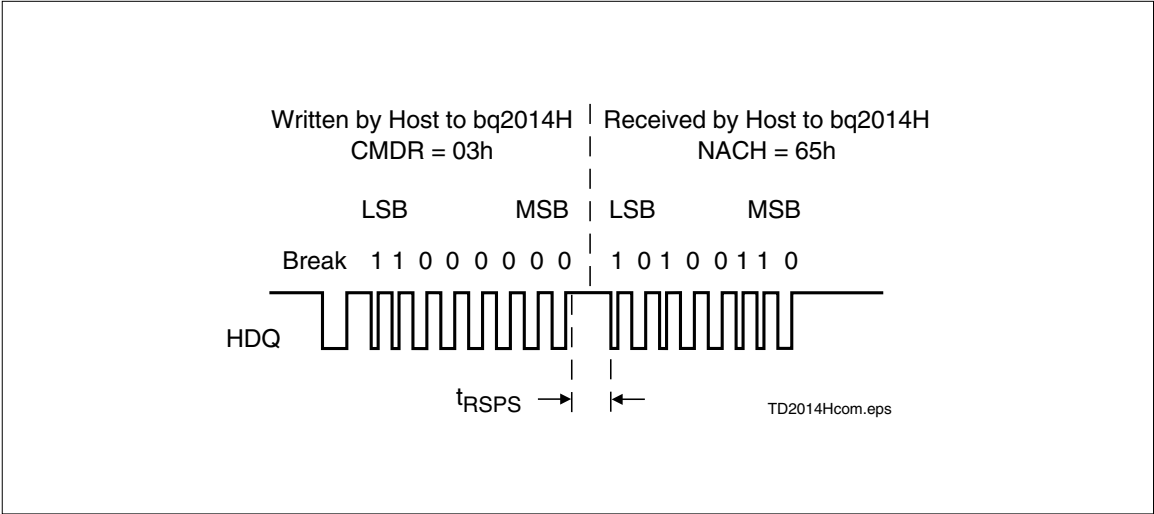

Figure 5. Typical Communication with the bq2014H

bq2014H

Table 8. bq2014H Command and Status Registers

Symbol	Register Name	Loc. (hex)	Read/Write	Control Field							
				7(MSB)	6	5	4	3	2	1	0(LSB)
FLGS1	Primary status flags register	01h	R	CHGS	BRP	0	CI	VDQ	1	EDV1	EDVF
TMP	Temperature register	02h	R	TMP3	TMP2	TMP1	TMP0	GG3	GG2	GG1	GG0
NACH	Nominal available capacity high byte register	03h	R/W	NACH7	NACH6	NACH5	NACH4	NACH3	NACH2	NACH1	NACH0
NACL	Nominal available capacity low byte register	17h	R/W	NACL7	NACL6	NACL5	NACL4	NACL3	NACL2	NACL1	NACL0
BATID	Battery identification register	04h	R/W	BATID7	BATID6	BATID5	BATID4	BATID3	BATID2	BATID1	BATID0
LMD	Last measured discharge register	05h	R/W	LMD7	LMD6	LMD5	LMD4	LMD3	LMD2	LMD1	LMD0
FLGS2	Secondary status flags register	06h	R	RSVD	DR2	DR1	DR0	ENINT	VQ	RSVD	OVLD
PPD	Program pin pull-down register	07h	R	RSVD	RSVD	RSVD	PPD5	PPD4	PPD3	PPD2	PPD1
PPU	Program pin pull-up register	08h	R	RSVD	RSVD	RSVD	PPU5	PPU4	PPU3	PPU2	PPU1
CPI	Capacity inaccurate count register	09h	R/W	CPI7	CPI6	CPI5	CPI4	CPI3	CPI2	CPI1	CPI0
VSB	Battery voltage register	0bh	R	VSB7	VSB6	VSB5	VSB4	VSB3	VSB2	VSB1	VSB0
VTS	End-of-discharge threshold select register	0ch	R/W	VTS7	VTS6	VTS5	VTS4	VTS3	VTS2	VTS1	VTS0
CACT	Temperature and discharge rate compensated available capacity	0dh	R/W	CACT7	CACT6	CACT5	CACT4	CACT3	CACT2	CACT1	CACT0
CACD	Discharge rate compensated available capacity	0eh	R/W	CACD7	CACD6	CACD5	CACD4	CACD3	CACD2	CACD1	CACD0
SAEH	Scaled available energy high byte register	0fh	R	SAEH7	SAEH6	SAEH5	SAEH4	SAEH3	SAEH2	SAEH1	SAEH0
SAEL	Scaled available energy low byte register	10h	R	SAEL7	SAEL6	SAEL5	SAEL4	SAEL3	SAEL2	SAEL1	SAEL0
RCAC	Relative CAC	11h	R	-	RCAC6	RCAC5	RCAC4	RCAC3	RCAC2	RCAC1	RCAC0
VSRH	Current scale high	12h	R	VSRH7	VSRH6	VSRH5	VSRH4	VSRH3	VSRH2	VSRH1	VSRH0
VSRL	Current scale low	13h	R	VSRL7	VSRL6	VSRL5	VSRL4	VSRL3	VSRL2	VSRL1	VSRL0
DCR	Discharge register	18h	R/W	DCR7	DCR6	DCR5	DCR4	DCR3	DCR2	DCR1	DCR0
PPFC	Program pin data	1eh	R/W	RSVD	RSVD	RSVD	RSVD	RSVD	RSVD	RSVD	RSVD
INTSS	VOS Interrupt	38h	R/W	RSVD	RSVD	RSVD	RSVD	DCHGI	RSVD	RSVD	CHGI

Notes: RSVD = reserved.
All other registers not documented are reserved.

The **capacity inaccurate** flag (CI) is used to warn the user that the battery has been charged a substantial number of times since LMD has been updated. The CI flag is asserted on the 64th charge after the last LMD update or when the bq2014H is reset. The flag is cleared after an LMD update.

The CI values are

FLGS1 Bits							
7	6	5	4	3	2	1	0
-	-	-	CI	-	-	-	-

where CI is

- 0 When LMD is updated with a valid full discharge
- 1 After the 64th valid charge action with no LMD updates or the bq2014H is reset

The **valid discharge** flag (VDQ) is asserted when the bq2014H is discharged from $NAC = 0.94 * LMD$. The flag remains set until either LMD is updated or one of three actions that can clear VDQ occurs:

- When NAC has been reduced by more than 6.25% because of self-discharge since VDQ was set.
- A valid charge action is sustained at $V_{SRO} > V_{SRQ}$ for at least 2 NAC updates.
- The EDV1 flag was set at a temperature below 0°C

The VDQ values are

FLGS1 Bits							
7	6	5	4	3	2	1	0
-	-	-	-	VDQ	-	-	-

where VDQ is

- 0 Self-discharge of more than 6.25% of NAC, valid charge action detected, EDV1 asserted with the temperature less than 0°C, or reset
- 1 On first discharge after $NAC \geq 0.94 * LMD$

The **first end-of-discharge warning** flag (EDV1) warns the user that the battery is almost empty. The first segment pin, SEG₁, is modulated at a 4Hz rate if the display is enabled once EDV1 is asserted, which should warn the user that loss of battery power is imminent. The EDV1 flag is latched until a valid charge has been detected. The EDV1 threshold is externally controlled via the VTS register (see Voltage Threshold Register).

The EDV1 values are

FLGS1 Bits							
7	6	5	4	3	2	1	0
-	-	-	-	-	-	EDV1	-

where EDV1 is

- 0 Valid charge action detected, $V_{SB} \geq V_{TS}$
- 1 $V_{SB} < V_{TS}$ providing that the discharge rate is $< 2C$ (OVLN not set)

The **final end-of-discharge warning** flag (EDVF) flag is used to warn that battery power is at a failure condition. All segment drivers are turned off. The EDVF flag is latched until a valid charge has been detected. The EDVF threshold is set 25mV below the EDV1 threshold.

The EDVF values are

FLGS1 Bits							
7	6	5	4	3	2	1	0
-	-	-	-	-	-	-	EDVF

where EDVF is

- 0 Valid charge action detected, $V_{SB} \geq (V_{TS} - 25mV)$
- 1 $V_{SB} < (V_{TS} - 25mV)$ providing the discharge rate is $< 2C$

Temperature Register (TMP)

The TMP register (address=02h) contains the battery temperature.

The bq2014H contains an internal temperature sensor. The temperature is used to set charge and discharge efficiency factors as well as to adjust the self-discharge coefficient. The temperature register contents may be translated as shown in Table 9.

TMP Temperature Bits							
7	6	5	4	3	2	1	0
TMP3	TMP2	TMP1	TMP0	-	-	-	-

The bq2014H calculates the gas gauge bits, GG3-GG0 as a function of CACT and LMD. The results of the calculation give available capacity in $\frac{1}{16}$ increments from 0 to $\frac{15}{16}$.

TMP Gas Gauge Bits							
7	6	5	4	3	2	1	0
-	-	-	-	GG3	GG2	GG1	GG0

bq2014H

Table 9. Temperature Register

TMP3	TMP2	TMP1	TMP0	Temperature
0	0	0	0	T < -30°C
0	0	0	1	-30°C < T < -20°C
0	0	1	0	-20°C < T < -10°C
0	0	1	1	-10°C < T < 0°C
0	1	0	0	0°C < T < 10°C
0	1	0	1	10°C < T < 20°C
0	1	1	0	20°C < T < 30°C
0	1	1	1	30°C < T < 40°C
1	0	0	0	40°C < T < 50°C
1	0	0	1	50°C < T < 60°C
1	0	1	0	60°C < T < 70°C
1	0	1	1	70°C < T < 80°C
1	1	0	0	T > 80°C

Nominal Available Capacity Registers (NACH/NACL)

The NACH high-byte register (address=03h) and the NACL low-byte register (address=17h) are the main gas gauging registers for the bq2014H. The NAC registers are incremented during charge actions and decremented during discharge and self-discharge actions. NACH and NACL are set to 0 during a bq2014H reset.

Writing to the NAC registers affects the available charge counts and, therefore, affects the bq2014H gas gauge operation. Do not write the NAC registers to a value greater than LMD.

Battery Identification Register (BATID)

The BATID register (address=04h) is available for use by the system to determine the type of battery pack. The BATID contents are retained as long as VRBI is greater than 2V. The contents of BATID have no effect on the operation of the bq2014H. There is no default setting for this register.

Last Measured Discharge Register (LMD)

LMD is the register (address=05h) that the bq2014H uses as a measured full reference. The bq2014H adjusts LMD based on the measured discharge capacity of the battery from full to empty. In this way the bq2014H updates the capacity of the battery. LMD is set to PFC during a bq2014H reset.

LMD is set to DCR upon the first valid charge after EDV is set if VDQ is set.

If DCR < 0.94 LMD, then LMD is set to 0.94 * LMD.

Secondary Status Flags Register (FLGS2)

The FLGS2 register (address=06h) contains the secondary bq2014H flags.

Bit 7 and bit 1 of FLGS2 are reserved. Do not write to these bits.

The **discharge rate** flags, DR2–0, are bits 6–4.

FLGS2 Bits							
7	6	5	4	3	2	1	0
-	DR2	DR1	DR0	-	-	-	-

They are used to determine the current discharge regime as follows:

DR2	DR1	DR0	Discharge Rate
0	0	0	DRATE < 0.5C
0	0	1	0.5C ≤ DRATE < 2C
0	1	0	2C < DRATE

The **enable interrupt** flag (ENINT) is a test bit used to determine VSR activity sensed by the bq2014H. The state of this bit will vary and should be ignored by the system.

FLGS2 Bits							
7	6	5	4	3	2	1	0
-	-	-	-	ENINT	-	-	-

The **valid charge** flag (VQ), bit 2 of FLGS2, is used to indicate whether the bq2014H recognizes a valid charge condition. This bit is reset on the first discharge after NAC = LMD.

The VQ values are

FLGS2 Bits							
7	6	5	4	3	2	1	0
-	-	-	-	-	VQ	-	-

where VQ is

- 0 Valid charge action not detected between a discharge from NAC = LMD and EDV1
- 1 Valid charge action detected

The **overload** flag (OVL D) is asserted when a discharge rate in excess of 2C is detected. OVL D remains asserted as long as the condition persists and is cleared 0.5 seconds after the rate drops below 2C. The overload condition is used to stop sampling of the battery terminal characteristics for end-of-discharge determination.

FLGS2 Bits							
7	6	5	4	3	2	1	0
-	-	-	-	-	-	-	OVLD

Program Pin Pull-Down Register (PPD)

The PPD register (address=07h) contains some of the programming pin information for the bq2014H. The segment drivers, SEG₁₋₅, have a corresponding PPD register location, PPD₁₋₅. A given location is set if a pull-down resistor has been detected on its corresponding segment driver. For example, if SEG₁ and SEG₄ have pull-down resistors, the contents of PPD are xxx01001.

Program Pin Pull-Up Register (PPU)

The PPU register (address=08h) contains the rest of the programming pin information for the bq2014H. The segment drivers, SEG₁₋₅, have a corresponding PPU register location, PPU₁₋₅. A given location is set if a pull-up resistor has been detected on its corresponding segment driver. For example, if SEG₃ and SEG₅ have pull-up resistors, the contents of PPU are xxx10100.

PPD/PPU Bits							
7	6	5	4	3	2	1	0
RSVD	RSVD	RSVD	PPU ₅	PPU ₄	PPU ₃	PPU ₂	PPU ₁
RSVD	RSVD	RSVD	PPD ₅	PPD ₄	PPD ₃	PPD ₂	PPD ₁

Capacity Inaccurate Count Register (CPI)

The CPI register (address=09h) is used to indicate the number of times a battery has been charged without an LMD update. Because the capacity of a rechargeable battery varies with age and operating conditions, the bq2014H adapts to the changing capacity over time. A complete discharge from full (NAC ≥ 0.94 * LMD) to empty (EDV₁=1) is required to perform an LMD update assuming there have been no intervening valid charges, the temperature is greater than or equal to 0°C, and there has been no more than a 6% self-discharge reduction.

The CPI register is incremented every time a valid charge is detected. When NAC ≥ 0.94 * LMD, however, the CPI register increments on the first valid charge; CPI does not increment again for a valid charge until NAC < 0.94 * LMD. This prevents continuous trickle charging from incrementing CPI if self-discharge decrements NAC. The CPI register increments to 255 without rolling over. When the contents of CPI are incremented to 64, the capacity inaccurate flag, CI, is asserted in the FLGS1 register. The CPI register is reset whenever an update of the LMD register is performed, and the CI flag is also cleared.

Battery Voltage Register (VSB)

The battery voltage register is used to read the single-cell battery voltage on the SB pin. The VSB register (address = 0Bh) is updated approximately once per second with the present value of the battery voltage.

$$V_{SB} = 1.2V * (VSB/256).$$

VSB Register Bits							
7	6	5	4	3	2	1	0
VSB7	VSB6	VSB5	VSB4	VSB3	VSB2	VSB1	VSB0

Voltage Threshold Register (VTS)

The end-of-discharge threshold voltages (EDV1 and EDVF) can be set using the VTS register (address = 0Ch). The VTS register sets the EDV1 trip point. EDVF is set 25mV below EDV1. The default value in the VTS register is A2h, representing EDV1 = 0.76V and EDVF = 0.735V. EDV1 = 1.2V * (VTS/256).

VTS Register Bits							
7	6	5	4	3	2	1	0
VTS7	VTS6	VTS5	VTS4	VTS3	VTS2	VTS1	VTS0

Compensated Available Charge Registers (CACT/CACD)

The CACD register (address = 0Eh) contains the NAC value compensated for discharge rate. This is a monotonically decreasing value during discharge. If the discharge rate is > 2C then this value is lower than NAC. CACD is updated only when the discharge rate compensated NAC value is a lower value than CACD during discharge. During charge, CACD is continuously updated with the NAC value.

The CACT register (address = 0Dh) contains the CACD value compensated for temperature. CACT will contain a value lower than CACD when the battery temperature is below 10°C. The CACT value is also used in calculating the LED display pattern.

Scaled Available Energy Registers (SAEH/SAEL)

The SAEH high-byte register (address = 0Fh) and the SAEL low-byte register (address = 10h) are used to scale battery voltage and CACT to a value that can be translated to watt-hours remaining under the present conditions.

Relative CAC Register (RCAC)

The RCAC register (address = 11h) provides the relative battery state-of-charge by dividing CACT by LMD.

bq2014H

RCAC varies from 0 to 64h representing relative state-of-charge from 0 to 100%.

Current Scale Register (VSRH/VSRL)

The VSRH register (address = 12h) and the VSRL register (address = 13h) report the average signal across the SR and VSS pins. The bq2050H updates this register pair every 22.5s. VSRH (high-byte) and VSRL (low-byte) form a 16-bit signed integer value representing the average current during this time. The battery pack current can be calculated from:

$$|I(\text{mA})| = (\text{VSRH} * 256 + \text{VSRL}) / (8 * R_S)$$

where:

R_S = sense resistor value in Ω .
VSRH = high-byte value of battery current
VSRL = low-byte value of battery current

The bq2014H indicates an average discharge current with a "1" in the MSB position of the VSRH register. To calculate discharge current, use the 2's complement if the concatenated register contents in the above equation.

Discharge Count Register (DCR)

The DCR register (address = 18h) stores the high-byte of the discharge count. DCR is reset to zero at the start of a valid discharge cycle and can count to a maximum of FFh. DCR will not increment if EDV1 = 1 and will not roll over from FFh.

Program Pin Full Count (PPFC)

The PPFC register contains information concerning the program pin configuration. This information is used to determine the data integrity of the bq2014H. **The only approved user application for this register is to write a zero to this register as part of a reset request.**

The recommended reset method for the bq2014H is

- Write PPFC to zero
- Write LMD to zero

After these operations, a software reset will occur.

Resetting the bq2014H sets the following:

- LMD = PFC
- CPI, VDQ, RCAC, NACH/L, CACH/L, SAEH/L, NMCV = 0
- CI and BRP = 1

Voltage Offset (V_{OS}) Interrupt (INTSS)

The INTSS register (address = 38h) is useful during initial characterization of bq2014H designs. When the bq2014H counts a charge pulse, CHGI (bit 0) will be set to 1. When the bq2014H counts a discharge pulse, DCHGI (bit 3) will be set to 1. All other locations in the INTSS register are reserved.

Display

The bq2014H can directly display capacity information using low-power LEDs. If LEDs are used, the program pins should be resistively tied to VCC or VSS for a program high or program low, respectively.

The bq2014H displays the battery charge state in relative mode. In relative mode, the battery charge is represented as a percentage of the LMD. Each LED segment represents 20% of the LMD.

The capacity display is also adjusted for the present battery temperature and discharge rate. The temperature adjustment reflects the available capacity at a given temperature but does not affect the NAC register. The temperature adjustments are detailed in the CACT and CACD register descriptions.

When $\overline{\text{DISP}}$ is tied to VCC, the SEG₁₋₅ outputs are inactive. When DISP is left floating, the display becomes active whenever the bq2014H detects a charge in progress $\text{VSRO} > \text{VSRQ}$. When pulled low, the segment outputs become active for a period of four seconds, ± 0.5 seconds.

The segment outputs are modulated as two banks, with segments 1, 3, and 5 alternating with segments 2 and 4. The segment outputs are modulated at approximately 100Hz with each segment bank active for 30% of the period.

SEG₁ blinks at a 4Hz rate whenever V_{SB} has been detected to be below V_{EDV1} (EDV1 = 1), indicating a low-battery condition. V_{SB} below V_{EDVF} (EDVF = 1) disables the display output.

Microregulator

A micropower source for the bq2014H can be inexpensively built using a FET and an external resistor. (See Figure 1.)

Absolute Maximum Ratings

Symbol	Parameter	Minimum	Maximum	Unit	Notes
V _{CC}	Relative to V _{SS}	-0.3	+7.0	V	
All other pins	Relative to V _{SS}	-0.3	+7.0	V	
REF	Relative to V _{SS}	-0.3	+8.5	V	Current limited by R1 (see Figure 1)
V _{SR}	Relative to V _{SS}	-0.3	V _{CC} +0.7	V	100kΩ series resistor should be used to protect SR in case of a shorted battery.
T _{OPR}	Operating temperature	0	+70	°C	Commercial

Note: Permanent device damage may occur if **Absolute Maximum Ratings** are exceeded. Functional operation should be limited to the Recommended DC Operating Conditions detailed in this data sheet. Exposure to conditions beyond the operational limits for extended periods of time may affect device reliability.

DC Voltage Thresholds (T_A = T_{OPR}; V = 3.0 to 6.5V)

Symbol	Parameter	Minimum	Typical	Maximum	Unit	Notes
VEDV1	First empty warning	0.73	0.76	0.79	V	SB, default
VEDVF	Final empty warning	VEDV1 - 0.035	VEDV1 - 0.025	VEDV1 - 0.015	V	SB, default
VSRO	SR sense range	-300	-	+500	mV	SR, V _{SR} + V _{OS}
VSRQ	Valid charge	250	-	-	μV	V _{SR} + V _{OS} (see note)
VSRD	Valid discharge	-	-	-250	μV	V _{SR} + V _{OS} (see note)

Note: V_{OS} is affected by PC board layout. Proper layout guidelines should be followed for optimal performance. See "LayoutConsiderations."

bq2014H

DC Electrical Characteristics (T_A = T_{OPR})

Symbol	Parameter	Minimum	Typical	Maximum	Unit	Notes
V _{CC}	Supply voltage	3.0	4.25	6.5	V	V _{CC} excursion from < 2.0V to ≥ 3.0V initializes the unit.
V _{OS}	Offset referred to V _{SR}	-	±50	±150	μV	$\overline{DISP} = V_{CC}$
V _{REF}	Reference at 25°C	5.7	6.0	6.3	V	I _{REF} = 5μA
	Reference at -40°C to +85°C	4.5	-	7.5	V	I _{REF} = 5μA
R _{REF}	Reference input impedance	2.0	5.0	-	MΩ	V _{REF} = 3V
I _{CC}	Normal operation	-	90	135	μA	V _{CC} = 3.0V, HDQ = 0
		-	120	180	μA	V _{CC} = 4.25V, HDQ = 0
		-	170	250	μA	V _{CC} = 6.5V, HDQ = 0
V _{SB}	Battery input	0	-	V _{CC}	V	
R _{SBmax}	SB input impedance	10	-	-	MΩ	0 < V _{SB} < V _{CC}
I _{DISP}	\overline{DISP} input leakage	-	-	5	μA	V _{DISP} = V _{SS}
I _{LCOM}	LCOM input leakage	-0.2	-	0.2	μA	$\overline{DISP} = V_{CC}$
I _{RBI}	RBI data retention current	-	-	100	nA	V _{RBI} > V _{CC} < 3V
R _{HDQ}	Internal pulldown	500	-	-	KΩ	
R _{SR}	SR input impedance	10	-	-	MΩ	-200mV < V _{SR} < V _{CC}
V _{IHPFC}	Logic input high	V _{CC} - 0.2	-	-	V	PROG ₁₋₅
V _{LIPFC}	Logic input low	-	-	V _{SS} + 0.2	V	PROG ₁₋₅
V _{IZPFC}	Logic input Z	float	-	float	V	PROG ₁₋₅
V _{OLSL}	SEG output low, low V _{CC}	-	0.1	-	V	V _{CC} = 3V, I _{OOLS} ≤ 1.75mA SEG ₁₋₅
V _{OLSH}	SEG output low, high V _{CC}	-	0.4	-	V	V _{CC} = 6.5V, I _{OOLS} ≤ 11.0mA SEG ₁₋₅
V _{OHML}	LCOM output high, low V _{CC}	V _{CC} - 0.3	-	-	V	V _{CC} = 3V, I _{OHLCOM} = -5.25mA
V _{OHMH}	LCOM output high, high V _{CC}	V _{CC} - 0.6	-	-	V	V _{CC} > 3.5V, I _{OHLCOM} = -33.0mA
I _{OOLS}	SEG sink current	11.0	-	-	mA	At V _{OLSH} = 0.4V, V _{CC} = 6.5V
I _{OOL}	Open-drain sink current	5.0	-	-	mA	At V _{OL} = V _{SS} + 0.3V, HDQ
V _{OL}	Open-drain output low	-	-	0.3	V	I _{OOL} ≤ 5mA, HDQ
V _{IHDQ}	HDQ input high	2.5	-	-	V	HDQ
V _{ILDQ}	HDQ input low	-	-	0.8	V	HDQ
R _{PROG}	Soft pull-up or pull-down resistor value (for programming)	-	-	200	KΩ	PROG ₁₋₅
R _{FLOAT}	Float state external impedance	-	5	-	MΩ	PROG ₁₋₅

Note: All voltages relative to V_{SS}.

High-Speed Serial Communication Timing Specification (TA = TOPR)

Symbol	Parameter	Minimum	Typical	Maximum	Unit	Notes
tCYCH	Cycle time, host to bq2014H (write)	190	-	-	μs	See note
tCYCB	Cycle time, bq2014H to host (read)	190	205	250	μs	
tSTRH	Start hold, host to bq2014H (write)	5	-	-	ns	
tSTRB	Start hold, bq2014H to host (read)	32	-	-	μs	
tDSU	Data setup	-	-	50	μs	
tDSUB	Data setup	-	-	50	μs	
tDH	Data hold	90	-	-	μs	
tDV	Data valid	-	-	80	μs	
tSSU	Stop setup	-	-	145	μs	
tSSUB	Stop setup	-	-	145	μs	
tRSPS	Response time, bq2014H to host	190	-	320	μs	
tB	Break	190	-	-	μs	
tBR	Break recovery	40	-	-	μs	

Note: The open-drain HDQ pin should be pulled to at least VCC by the host system for proper HDQ operation. HDQ may be left floating if the serial interface is not used.

bq2014H

Break Timing

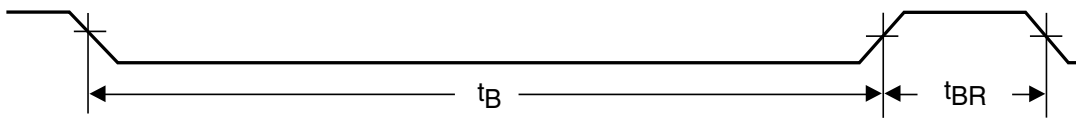

TD201803.eps

Host to bq2014H

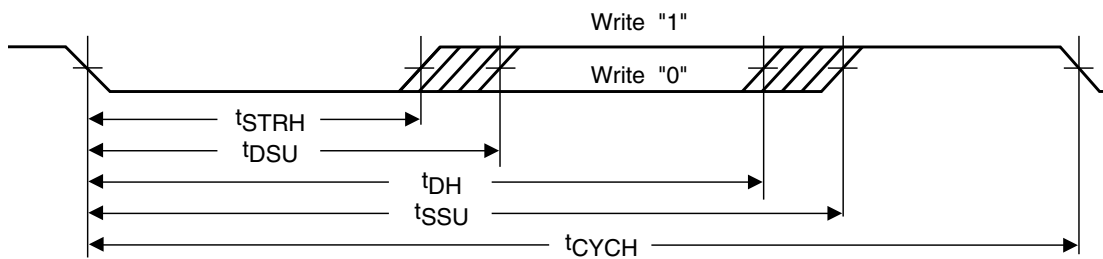

bq2014H to Host

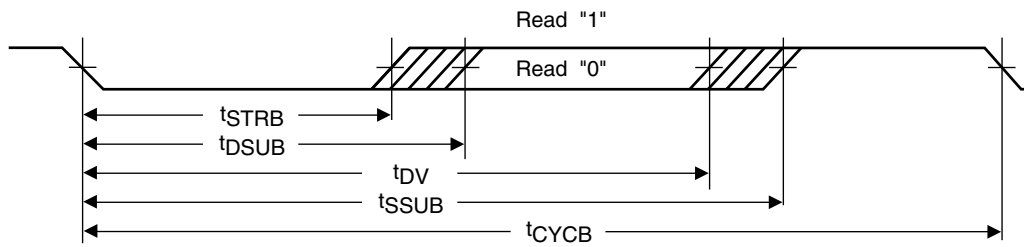

16-Pin SOIC Narrow (SN)

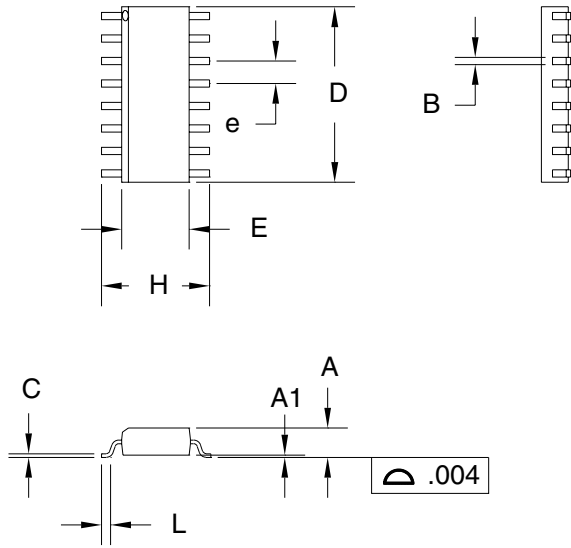

16-Pin SN (0.150" SOIC)

Dimension	Inches		Millimeters	
	Min.	Max.	Min.	Max.
A	0.060	0.070	1.52	1.78
A1	0.004	0.010	0.10	0.25
B	0.013	0.020	0.33	0.51
C	0.007	0.010	0.18	0.25
D	0.385	0.400	9.78	10.16
E	0.150	0.160	3.81	4.06
e	0.045	0.055	1.14	1.40
H	0.225	0.245	5.72	6.22
L	0.015	0.035	0.38	0.89

Ordering Information

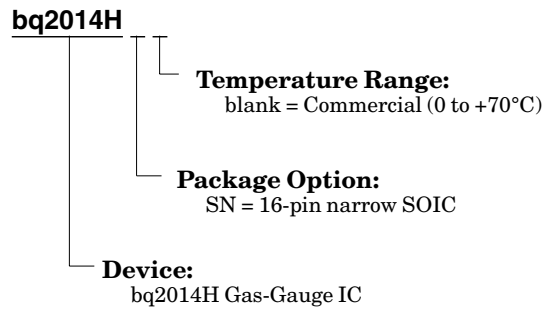

PACKAGING INFORMATION

Orderable Device	Status (1)	Package Type	Package Drawing	Pins	Package Qty	Eco Plan (2)	Lead/Ball Finish (6)	MSL Peak Temp (3)	Op Temp (°C)	Device Marking (4/5)	Samples
BQ2014HSN	NRND	SOIC	D	16	40	Green (RoHS & no Sb/Br)	CU NIPDAU	Level-2-260C-1 YEAR	0 to 70	2014H A509	
BQ2014HSNTR	NRND	SOIC	D	16	2500	Green (RoHS & no Sb/Br)	CU NIPDAU	Level-2-260C-1 YEAR	0 to 70	2014H A509	

(1) The marketing status values are defined as follows:

ACTIVE: Product device recommended for new designs.

LIFEBUY: TI has announced that the device will be discontinued, and a lifetime-buy period is in effect.

NRND: Not recommended for new designs. Device is in production to support existing customers, but TI does not recommend using this part in a new design.

PREVIEW: Device has been announced but is not in production. Samples may or may not be available.

OBSOLETE: TI has discontinued the production of the device.

(2) **RoHS:** TI defines "RoHS" to mean semiconductor products that are compliant with the current EU RoHS requirements for all 10 RoHS substances, including the requirement that RoHS substance do not exceed 0.1% by weight in homogeneous materials. Where designed to be soldered at high temperatures, "RoHS" products are suitable for use in specified lead-free processes. TI may reference these types of products as "Pb-Free".

RoHS Exempt: TI defines "RoHS Exempt" to mean products that contain lead but are compliant with EU RoHS pursuant to a specific EU RoHS exemption.

Green: TI defines "Green" to mean the content of Chlorine (Cl) and Bromine (Br) based flame retardants meet JS709B low halogen requirements of <=1000ppm threshold. Antimony trioxide based flame retardants must also meet the <=1000ppm threshold requirement.

(3) MSL, Peak Temp. - The Moisture Sensitivity Level rating according to the JEDEC industry standard classifications, and peak solder temperature.

(4) There may be additional marking, which relates to the logo, the lot trace code information, or the environmental category on the device.

(5) Multiple Device Markings will be inside parentheses. Only one Device Marking contained in parentheses and separated by a "~" will appear on a device. If a line is indented then it is a continuation of the previous line and the two combined represent the entire Device Marking for that device.

(6) Lead/Ball Finish - Orderable Devices may have multiple material finish options. Finish options are separated by a vertical ruled line. Lead/Ball Finish values may wrap to two lines if the finish value exceeds the maximum column width.

Important Information and Disclaimer:The information provided on this page represents TI's knowledge and belief as of the date that it is provided. TI bases its knowledge and belief on information provided by third parties, and makes no representation or warranty as to the accuracy of such information. Efforts are underway to better integrate information from third parties. TI has taken and continues to take reasonable steps to provide representative and accurate information but may not have conducted destructive testing or chemical analysis on incoming materials and chemicals. TI and TI suppliers consider certain information to be proprietary, and thus CAS numbers and other limited information may not be available for release.

In no event shall TI's liability arising out of such information exceed the total purchase price of the TI part(s) at issue in this document sold by TI to Customer on an annual basis.

TAPE AND REEL INFORMATION

QUADRANT ASSIGNMENTS FOR PIN 1 ORIENTATION IN TAPE

*All dimensions are nominal

Device	Package Type	Package Drawing	Pins	SPQ	Reel Diameter (mm)	Reel Width W1 (mm)	A0 (mm)	B0 (mm)	K0 (mm)	P1 (mm)	W (mm)	Pin1 Quadrant
BQ2014HSNTR	SOIC	D	16	2500	330.0	16.4	6.5	10.3	2.1	8.0	16.0	Q1

TAPE AND REEL BOX DIMENSIONS



*All dimensions are nominal

Device	Package Type	Package Drawing	Pins	SPQ	Length (mm)	Width (mm)	Height (mm)
BQ2014HSNTR	SOIC	D	16	2500	367.0	367.0	38.0

D (R-PDSO-G16)

PLASTIC SMALL OUTLINE



- NOTES:
- A. All linear dimensions are in inches (millimeters).
 - B. This drawing is subject to change without notice.
 - C. Body length does not include mold flash, protrusions, or gate burrs. Mold flash, protrusions, or gate burrs shall not exceed 0.006 (0,15) each side.
 - D. Body width does not include interlead flash. Interlead flash shall not exceed 0.017 (0,43) each side.
 - E. Reference JEDEC MS-012 variation AC.

D (R-PDSO-G16)

PLASTIC SMALL OUTLINE



- NOTES:
- All linear dimensions are in millimeters.
 - This drawing is subject to change without notice.
 - Publication IPC-7351 is recommended for alternate designs.
 - Laser cutting apertures with trapezoidal walls and also rounding corners will offer better paste release. Customers should contact their board assembly site for stencil design recommendations. Refer to IPC-7525 for other stencil recommendations.
 - Customers should contact their board fabrication site for solder mask tolerances between and around signal pads.

IMPORTANT NOTICE

Texas Instruments Incorporated (TI) reserves the right to make corrections, enhancements, improvements and other changes to its semiconductor products and services per JESD46, latest issue, and to discontinue any product or service per JESD48, latest issue. Buyers should obtain the latest relevant information before placing orders and should verify that such information is current and complete.

TI's published terms of sale for semiconductor products (<http://www.ti.com/sc/docs/stdterms.htm>) apply to the sale of packaged integrated circuit products that TI has qualified and released to market. Additional terms may apply to the use or sale of other types of TI products and services.

Reproduction of significant portions of TI information in TI data sheets is permissible only if reproduction is without alteration and is accompanied by all associated warranties, conditions, limitations, and notices. TI is not responsible or liable for such reproduced documentation. Information of third parties may be subject to additional restrictions. Resale of TI products or services with statements different from or beyond the parameters stated by TI for that product or service voids all express and any implied warranties for the associated TI product or service and is an unfair and deceptive business practice. TI is not responsible or liable for any such statements.

Buyers and others who are developing systems that incorporate TI products (collectively, "Designers") understand and agree that Designers remain responsible for using their independent analysis, evaluation and judgment in designing their applications and that Designers have full and exclusive responsibility to assure the safety of Designers' applications and compliance of their applications (and of all TI products used in or for Designers' applications) with all applicable regulations, laws and other applicable requirements. Designer represents that, with respect to their applications, Designer has all the necessary expertise to create and implement safeguards that (1) anticipate dangerous consequences of failures, (2) monitor failures and their consequences, and (3) lessen the likelihood of failures that might cause harm and take appropriate actions. Designer agrees that prior to using or distributing any applications that include TI products, Designer will thoroughly test such applications and the functionality of such TI products as used in such applications.

TI's provision of technical, application or other design advice, quality characterization, reliability data or other services or information, including, but not limited to, reference designs and materials relating to evaluation modules, (collectively, "TI Resources") are intended to assist designers who are developing applications that incorporate TI products; by downloading, accessing or using TI Resources in any way, Designer (individually or, if Designer is acting on behalf of a company, Designer's company) agrees to use any particular TI Resource solely for this purpose and subject to the terms of this Notice.

TI's provision of TI Resources does not expand or otherwise alter TI's applicable published warranties or warranty disclaimers for TI products, and no additional obligations or liabilities arise from TI providing such TI Resources. TI reserves the right to make corrections, enhancements, improvements and other changes to its TI Resources. TI has not conducted any testing other than that specifically described in the published documentation for a particular TI Resource.

Designer is authorized to use, copy and modify any individual TI Resource only in connection with the development of applications that include the TI product(s) identified in such TI Resource. NO OTHER LICENSE, EXPRESS OR IMPLIED, BY ESTOPPEL OR OTHERWISE TO ANY OTHER TI INTELLECTUAL PROPERTY RIGHT, AND NO LICENSE TO ANY TECHNOLOGY OR INTELLECTUAL PROPERTY RIGHT OF TI OR ANY THIRD PARTY IS GRANTED HEREIN, including but not limited to any patent right, copyright, mask work right, or other intellectual property right relating to any combination, machine, or process in which TI products or services are used. Information regarding or referencing third-party products or services does not constitute a license to use such products or services, or a warranty or endorsement thereof. Use of TI Resources may require a license from a third party under the patents or other intellectual property of the third party, or a license from TI under the patents or other intellectual property of TI.

TI RESOURCES ARE PROVIDED "AS IS" AND WITH ALL FAULTS. TI DISCLAIMS ALL OTHER WARRANTIES OR REPRESENTATIONS, EXPRESS OR IMPLIED, REGARDING RESOURCES OR USE THEREOF, INCLUDING BUT NOT LIMITED TO ACCURACY OR COMPLETENESS, TITLE, ANY EPIDEMIC FAILURE WARRANTY AND ANY IMPLIED WARRANTIES OF MERCHANTABILITY, FITNESS FOR A PARTICULAR PURPOSE, AND NON-INFRINGEMENT OF ANY THIRD PARTY INTELLECTUAL PROPERTY RIGHTS. TI SHALL NOT BE LIABLE FOR AND SHALL NOT DEFEND OR INDEMNIFY DESIGNER AGAINST ANY CLAIM, INCLUDING BUT NOT LIMITED TO ANY INFRINGEMENT CLAIM THAT RELATES TO OR IS BASED ON ANY COMBINATION OF PRODUCTS EVEN IF DESCRIBED IN TI RESOURCES OR OTHERWISE. IN NO EVENT SHALL TI BE LIABLE FOR ANY ACTUAL, DIRECT, SPECIAL, COLLATERAL, INDIRECT, PUNITIVE, INCIDENTAL, CONSEQUENTIAL OR EXEMPLARY DAMAGES IN CONNECTION WITH OR ARISING OUT OF TI RESOURCES OR USE THEREOF, AND REGARDLESS OF WHETHER TI HAS BEEN ADVISED OF THE POSSIBILITY OF SUCH DAMAGES.

Unless TI has explicitly designated an individual product as meeting the requirements of a particular industry standard (e.g., ISO/TS 16949 and ISO 26262), TI is not responsible for any failure to meet such industry standard requirements.

Where TI specifically promotes products as facilitating functional safety or as compliant with industry functional safety standards, such products are intended to help enable customers to design and create their own applications that meet applicable functional safety standards and requirements. Using products in an application does not by itself establish any safety features in the application. Designers must ensure compliance with safety-related requirements and standards applicable to their applications. Designer may not use any TI products in life-critical medical equipment unless authorized officers of the parties have executed a special contract specifically governing such use. Life-critical medical equipment is medical equipment where failure of such equipment would cause serious bodily injury or death (e.g., life support, pacemakers, defibrillators, heart pumps, neurostimulators, and implantables). Such equipment includes, without limitation, all medical devices identified by the U.S. Food and Drug Administration as Class III devices and equivalent classifications outside the U.S.

TI may expressly designate certain products as completing a particular qualification (e.g., Q100, Military Grade, or Enhanced Product). Designers agree that it has the necessary expertise to select the product with the appropriate qualification designation for their applications and that proper product selection is at Designers' own risk. Designers are solely responsible for compliance with all legal and regulatory requirements in connection with such selection.

Designer will fully indemnify TI and its representatives against any damages, costs, losses, and/or liabilities arising out of Designer's non-compliance with the terms and provisions of this Notice.

Looking for pricing, stock, or lifecycle information?

Click below to explore more details on WIN SOURCE:

 [View BQ2014HSNTR](#) on WIN SOURCE

 [Texas Instruments](#) Information

Optimize Your Supply Chain with WIN SOURCE Solutions

-  Global Sourcing Solution
-  Obsolete Management
-  Cost Control Management
-  Shortage Management
-  Alternative Solution
-  Excess Inventory Management