



# THE DATASHEET OF BQ2002EPN





**UNITRODE**

# bq2002E/G

## NiCd/NiMH Fast-Charge Management ICs

### Features

- Fast charge of nickel cadmium or nickel-metal hydride batteries
- Direct LED output displays charge status
- Fast-charge termination by  $-\Delta V$ , maximum voltage, maximum temperature, and maximum time
- Internal band-gap voltage reference
- Optional top-off charge
- Selectable pulse trickle charge rates
- Low-power mode
- 8-pin 300-mil DIP or 150-mil SOIC

### General Description

The bq2002E and bq2002G Fast-Charge ICs are low-cost CMOS battery-charge controllers providing reliable charge termination for both NiCd and NiMH battery applications. Controlling a current-limited or constant-current supply allows the bq2002E/G to be the basis for a cost-effective stand-alone or system-integrated charger. The bq2002E/G integrates fast charge with optional top-off and pulsed-trickle control in a single IC for charging one or more NiCd or NiMH battery cells.

Fast charge is initiated on application of the charging supply or battery replacement. For safety, fast charge is inhibited if the battery temperature and voltage are outside configured limits.

Fast charge is terminated by any of the following:

- Peak voltage detection (PVD)
- Negative delta voltage ( $-\Delta V$ )
- Maximum voltage
- Maximum temperature
- Maximum time

After fast charge, the bq2002E/G optionally tops-off and pulse-trickles the battery per the pre-configured limits. Fast charge may be inhibited using the INH pin. The bq2002E/G may also be placed in low-standby-power mode to reduce system power consumption.

The bq2002E differs from the bq2002G only in that a slightly different set of fast-charge and top-off time limits is available. All differences between the two ICs are illustrated in Table 1.

### Pin Connections

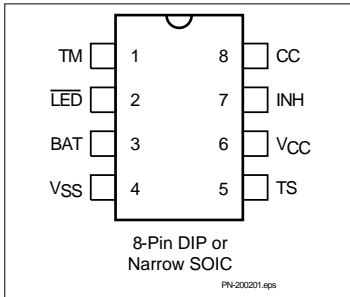

### Pin Names

TM	Timer mode select input	TS	Temperature sense input
$\overline{\text{LED}}$	Charging status output	V <sub>CC</sub>	Supply voltage input
BAT	Battery voltage input	INH	Charge inhibit input
V <sub>SS</sub>	System ground	CC	Charge control output

### bq2002E/G Selection Guide

Part No.	LBAT	TCO	HTF	LTF	$-\Delta V$	PVD	Fast Charge	t <sub>MTO</sub>	Top-Off	Maintenance
bq2002E	0.175 * V <sub>CC</sub>	0.5 * V <sub>CC</sub>	0.6 * V <sub>CC</sub>	None		✓	C/2	200	None	C/32
						✓	1C	80	C/16	C/32
					✓		2C	40	None	C/32
bq2002G	0.175 * V <sub>CC</sub>	0.5 * V <sub>CC</sub>	0.6 * V <sub>CC</sub>	None		✓	C/2	160	None	C/32
						✓	1C	80	C/16	C/32
					✓		2C	40	None	C/32

# bq2002E/G

## Pin Descriptions

<b>TM</b>	<b>Timer mode input</b>	A three-level input that controls the settings for the fast charge safety timer, voltage termination mode, top-off, pulse-trickle, and voltage hold-off time.
<b><math>\overline{\text{LED}}</math></b>	<b>Charging output status</b>	Open-drain output that indicates the charging status.
<b>BAT</b>	<b>Battery input voltage</b>	The battery voltage sense input. The input to this pin is created by a high-impedance resistor divider network connected between the positive and negative terminals of the battery.
<b>V<sub>SS</sub></b>	<b>System ground</b>	
<b>TS</b>	<b>Temperature sense input</b>	Input for an external battery temperature monitoring thermistor.
<b>V<sub>CC</sub></b>	<b>Supply voltage input</b>	5.0V ±20% power input.
<b>INH</b>	<b>Charge inhibit input</b>	When high, INH suspends the fast charge in progress. When returned low, the IC resumes operation at the point where initially suspended.

When high, INH suspends the fast charge in progress. When returned low, the IC resumes operation at the point where initially suspended.

### CC Charge control output

An open-drain output used to control the charging current to the battery. CC switching to high impedance (Z) enables charging current to flow, and low to inhibit charging current. CC is modulated to provide top-off, if enabled, and pulse trickle.

## Functional Description

Figure 2 shows a state diagram and Figure 3 shows a block diagram of the bq2002E/G.

### Battery Voltage and Temperature Measurements

Battery voltage and temperature are monitored for maximum allowable values. The voltage presented on the battery sense input, BAT, should represent a single-cell potential for the battery under charge. A resistor-divider ratio of

$$\frac{RB1}{RB2} = N - 1$$

is recommended to maintain the battery voltage within the valid range, where N is the number of cells, RB1 is the resistor connected to the positive battery terminal, and RB2 is the resistor connected to the negative battery terminal. See Figure 1.

**Note:** This resistor-divider network input impedance to end-to-end should be at least 200kΩ and less than 1 MΩ.

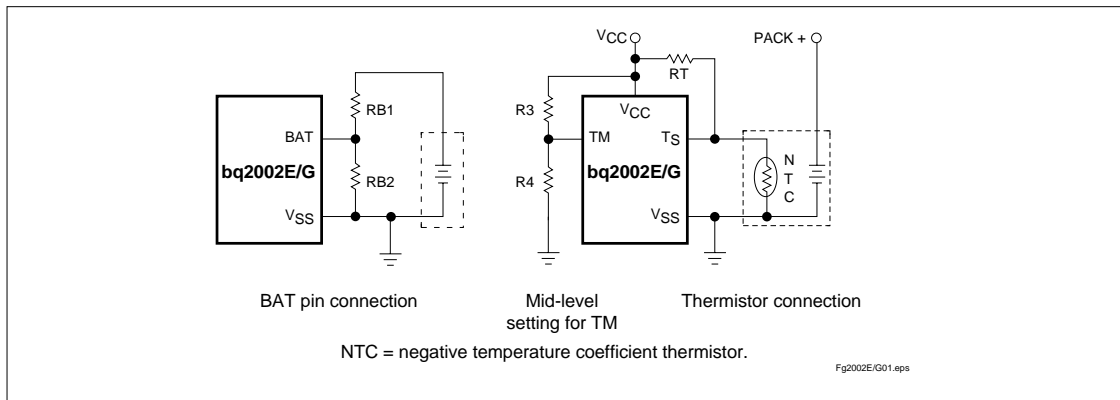

Figure 1. Voltage and Temperature Monitoring and TM Pin Configuration

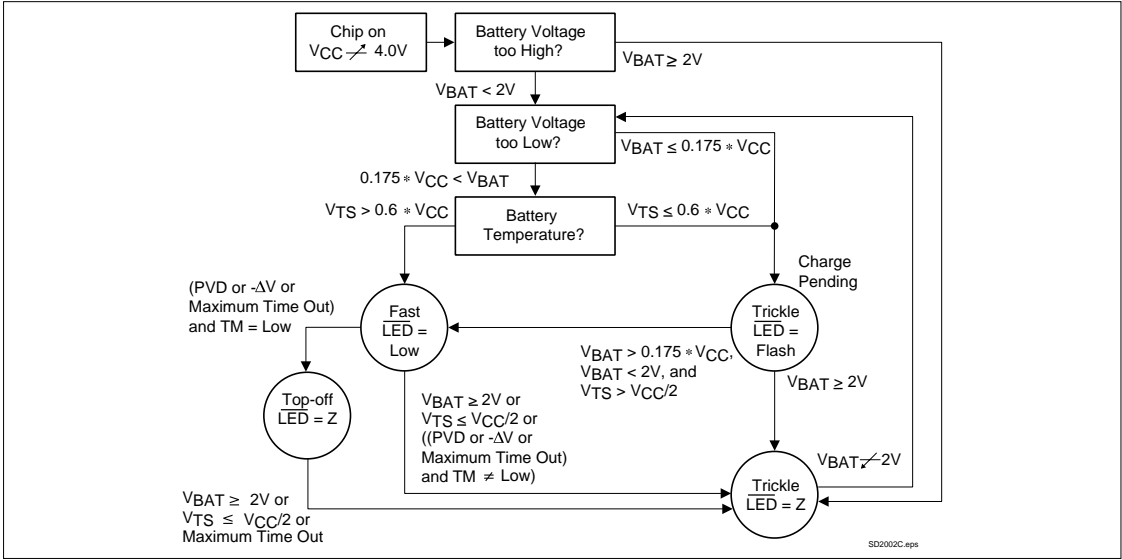

Figure 2. State Diagram

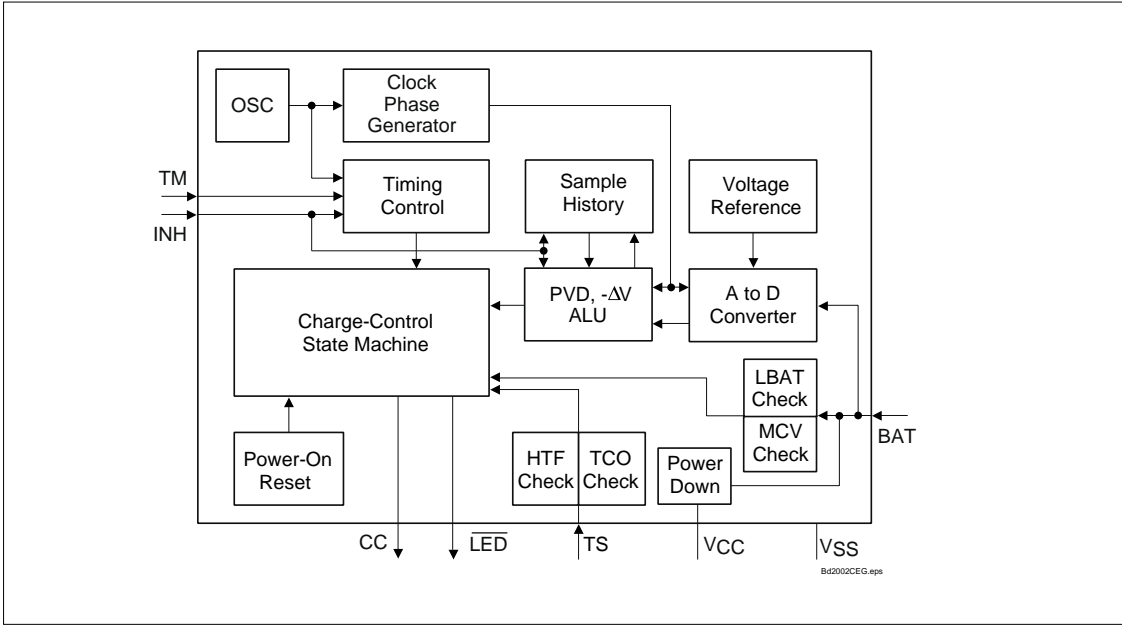
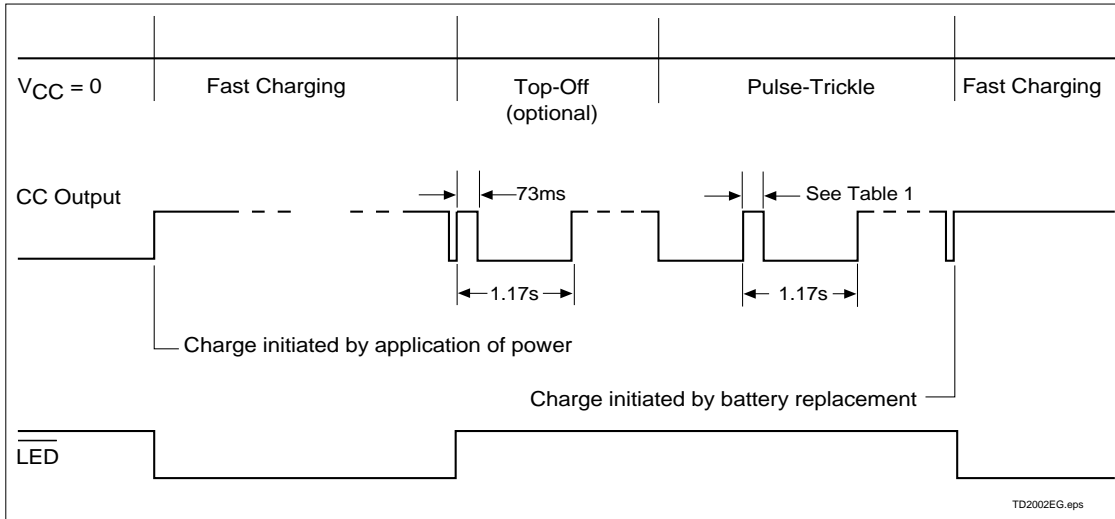

Figure 3. Block Diagram

# bq2002E/G



**Figure 4. Charge Cycle Phases**

A ground-referenced negative temperature coefficient thermistor placed near the battery may be used as a low-cost temperature-to-voltage transducer. The temperature sense voltage input at TS is developed using a resistor-thermistor network between  $V_{CC}$  and  $V_{SS}$ . See Figure 1.

### Starting A Charge Cycle

Either of two events starts a charge cycle (see Figure 4):

1. Application of power to  $V_{CC}$  or
2. Voltage at the BAT pin falling through the maximum cell voltage  $V_{MCV}$  where

$$V_{MCV} = 2V \pm 5\%.$$

If the battery is within the configured temperature and voltage limits, the IC begins fast charge. The valid battery voltage range is  $V_{LBAT} < V_{BAT} < V_{MCV}$ , where

**Table 1. Fast-Charge Safety Time/Hold-Off/Top-Off Table**

Corresponding Fast-Charge Rate	TM	Termination	Typical Fast-Charge and Top-Off Time Limits (minutes)		Typical PVD and $-\Delta V$ Hold-Off Time (seconds)	Top-Off Rate	Pulse-Trickle Rate	Pulse-Trickle Width (ms)	Maximum Synchronized Sampling Period (seconds)
			bq2002E	bq2002G					
C/2	Mid	PVD	200	160	300	Disabled	C/32	73	18.7
1C	Low	PVD	80	80	150	C/16	C/32	37	18.7
2C	High	$-\Delta V$	40	40	75	Disabled	C/32	18	9.4

**Notes:** Typical conditions = 25°C,  $V_{CC} = 5.0V$   
 Mid =  $0.5 * V_{CC} \pm 0.5V$   
 Tolerance on all timing is  $\pm 12\%$ .

$$V_{LBAT} = 0.175 * V_{CC} \pm 20\%$$

The valid temperature range is  $V_{TS} > V_{HTF}$  where

$$V_{HTF} = 0.6 * V_{CC} \pm 5\%.$$

If the battery voltage or temperature is outside of these limits, the IC pulse-trickle charges until the next new charge cycle begins.

If  $V_{MCV} < V_{BAT} < V_{PD}$  (see “Low-Power Mode”) when a new battery is inserted, a delay of 0.35 to 0.9s is imposed before the new charge cycle begins.

Fast charge continues until termination by one or more of the five possible termination conditions:

- Peak voltage detection (PVD)
- Negative delta voltage ( $-\Delta V$ )
- Maximum voltage
- Maximum temperature
- Maximum time

### PVD and $-\Delta V$ Termination

There are two modes for voltage termination, depending on the state of TM. For  $-\Delta V$  (TM = high), if  $V_{BAT}$  is lower than any previously measured value by  $12mV \pm 3mV$ , fast charge is terminated. For PVD (TM = low or mid), a decrease of  $2.5mV \pm 2.5mV$  terminates fast charge. The PVD and  $-\Delta V$  tests are valid in the range  $1V < V_{BAT} < 2V$ .

### Synchronized Voltage Sampling

Voltage sampling at the BAT pin for PVD and  $-\Delta V$  termination may be synchronized to an external stimulus using the INH input. Low-high-low input pulses between 100ns and 3.5ms in width must be applied at the INH pin with a frequency greater than the “maximum synchronized sampling period” set by the state of the TM pin as shown in Table 1. Voltage is sampled on the falling edge of such pulses.

If the time between pulses is greater than the synchronizing period, voltage sampling “free-runs” at once every 17 seconds. A sample is taken by averaging together voltage measurements taken  $57\mu s$  apart. The IC takes 32 measurements in PVD mode and 16 measurements in  $-\Delta V$  mode. The resulting sample periods (9.17 and 18.18ms, respectively) filter out harmonics centered around 55 and 109Hz. This technique minimizes the effect of any AC line ripple that may feed through the power supply from either 50 or 60Hz AC sources.

If the INH input remains high for more than 12ms, the voltage sample history kept by the IC and used for PVD and  $-\Delta V$  termination decisions is erased and a new history is started. Such a reset is required when transitioning from free-running to synchronized voltage sampling.

The response of the IC to pulses less than 100ns in width or between 3.5ms and 12ms is indeterminate. Tolerance on all timing is  $\pm 12\%$ .

### Voltage Termination Hold-off

A hold-off period occurs at the start of fast charging. During the hold-off time, the PVD and  $-\Delta V$  terminations are disabled. This avoids premature termination on the voltage spikes sometimes produced by older batteries when fast-charge current is first applied. Maximum voltage and temperature terminations are not affected by the hold-off period.

### Maximum Voltage, Temperature, and Time

Any time the voltage on the BAT pin exceeds the maximum cell voltage,  $V_{MCV}$ , fast charge or optional top-off charge is terminated.

Maximum temperature termination occurs anytime the voltage on the TS pin falls below the temperature cut-off threshold  $V_{TCO}$  where

$$V_{TCO} = 0.5 * V_{CC} \pm 5\%.$$

Maximum charge time is configured using the TM pin. Time settings are available for corresponding charge rates of C/2, 1C, and 2C. Maximum time-out termination is enforced on the fast-charge phase, then reset, and enforced again on the top-off phase, if selected. There is no time limit on the trickle-charge phase.

### Top-off Charge

An optional top-off charge phase may be selected to follow fast charge termination for 1C and C/2 rates. This phase may be necessary on NiMH or other battery chemistries that have a tendency to terminate charge before reaching full capacity. With top-off enabled, charging continues at a reduced rate after fast-charge termination for a period of time selected by the TM pin. (See Table 1.) During top-off, the CC pin is modulated at a duty cycle of 73ms active for every 1097ms inactive. This modulation results in an average rate 1/16th that of the fast charge rate. Maximum voltage, time, and temperature are the only termination methods enabled during top-off.

### Pulse-Trickle Charge

Pulse-trickle is used to compensate for self-discharge while the battery is idle in the charger. The battery is pulse-trickle charged by driving the CC pin active once every 1.17s for the period specified in Table 1. This results in a trickle rate of C/32.

### TM Pin

The TM pin is a three-level pin used to select the charge timer, top-off, voltage termination mode, trickle

## bq2002E/G

---

rate, and voltage hold-off period options. Table 1 describes the states selected by the TM pin. The mid-level selection input is developed by a resistor divider between  $V_{CC}$  and ground that fixes the voltage on TM at  $V_{CC}/2 \pm 0.5V$ . See Figure 4.

### Charge Status Indication

A fast charge in progress is uniquely indicated when the  $\overline{LED}$  pin goes low. The  $\overline{LED}$  pin is driven to the high-Z state for all conditions other than fast charge. Figure 2 outlines the state of the  $\overline{LED}$  pin during charge.

### Charge Inhibit

Fast charge and top-off may be inhibited by using the INH pin. When high, INH suspends all fast charge and top-off activity and the internal charge timer. INH freezes the current state of  $\overline{LED}$  until inhibit is removed. Temperature monitoring is not affected by the INH pin. During charge inhibit, the bq2002E/G continues to pulse-trickle charge the battery per the TM selection. When INH returns low, charge control and the charge timer resume from the point where INH became active.

### Low-Power Mode

The IC enters a low-power state when  $V_{BAT}$  is driven above the power-down threshold ( $V_{PD}$ ) where

$$V_{PD} = V_{CC} - (1V \pm 0.5V)$$

Both the CC pin and the  $\overline{LED}$  pin are driven to the high-Z state. The operating current is reduced to less than  $1\mu A$  in this mode. When  $V_{BAT}$  returns to a value below  $V_{PD}$ , the IC pulse-trickle charges until the next new charge cycle begins.

## Absolute Maximum Ratings

Symbol	Parameter	Minimum	Maximum	Unit	Notes
V <sub>CC</sub>	V <sub>CC</sub> relative to V <sub>SS</sub>	-0.3	+7.0	V	
V <sub>T</sub>	DC voltage applied on any pin excluding V <sub>CC</sub> relative to V <sub>SS</sub>	-0.3	+7.0	V	
T <sub>OPR</sub>	Operating ambient temperature	0	+70	°C	Commercial
T <sub>STG</sub>	Storage temperature	-40	+85	°C	
T <sub>SOLDER</sub>	Soldering temperature	-	+260	°C	10 sec max.
T <sub>BIAS</sub>	Temperature under bias	-40	+85	°C	

**Note:** Permanent device damage may occur if **Absolute Maximum Ratings** are exceeded. Functional operation should be limited to the Recommended DC Operating Conditions detailed in this data sheet. Exposure to conditions beyond the operational limits for extended periods of time may affect device reliability.

## DC Thresholds (T<sub>A</sub> = 0 to 70°C; V<sub>CC</sub> ±20%)

Symbol	Parameter	Rating	Tolerance	Unit	Notes
V <sub>TCO</sub>	Temperature cutoff	0.5 * V <sub>CC</sub>	±5%	V	V <sub>TS</sub> ≤ V <sub>TCO</sub> inhibits/terminates fast charge and top-off
V <sub>HTE</sub>	High temperature fault	0.6 * V <sub>CC</sub>	±5%	V	V <sub>TS</sub> < V <sub>HTE</sub> inhibits fast charge start
V <sub>MCV</sub>	Maximum cell voltage	2	±5%	V	V <sub>BAT</sub> ≥ V <sub>MCV</sub> inhibits/terminates fast charge and top-off
V <sub>LBAT</sub>	Minimum cell voltage	0.175 * V <sub>CC</sub>	±20%	V	V <sub>BAT</sub> < V <sub>LBAT</sub> inhibits fast charge start
-ΔV	BAT input change for -ΔV detection	-12	±3	mV	
PVD	BAT input change for PVD detection	-2.5	±2.5	mV	

## bq2002E/G

### Recommended DC Operating Conditions (T<sub>A</sub> = 0 to 70°C)

Symbol	Condition	Minimum	Typical	Maximum	Unit	Notes
V <sub>CC</sub>	Supply voltage	4.0	5.0	6.0	V	
V <sub>DET</sub>	-ΔV, PVD detect voltage	1	-	2	V	
V <sub>BAT</sub>	Battery input	0	-	V <sub>CC</sub>	V	
V <sub>TS</sub>	Thermistor input	0.5	-	V <sub>CC</sub>	V	V <sub>TS</sub> < 0.5V prohibited
V <sub>IH</sub>	Logic input high	0.5	-	-	V	INH
	Logic input high	V <sub>CC</sub> - 0.5	-	-	V	TM
V <sub>IM</sub>	Logic input mid	$\frac{V_{CC}}{2} - 0.5$	-	$\frac{V_{CC}}{2} + 0.5$	V	TM
V <sub>IL</sub>	Logic input low	-	-	0.1	V	INH
	Logic input low	-	-	0.5	V	TM
V <sub>OL</sub>	Logic output low	-	-	0.8	V	$\overline{\text{LED}}$ , CC, I <sub>OL</sub> = 10mA
V <sub>PD</sub>	Power down	V <sub>CC</sub> - 1.5	-	V <sub>CC</sub> - 0.5	V	V <sub>BAT</sub> ≥ V <sub>PD</sub> max. powers down bq2002E/G; V <sub>BAT</sub> < V <sub>PD</sub> min. = normal operation.
I <sub>CC</sub>	Supply current	-	-	500	μA	Outputs unloaded, V <sub>CC</sub> = 5.1V
I <sub>SB</sub>	Standby current	-	-	1	μA	V <sub>CC</sub> = 5.1V, V <sub>BAT</sub> = V <sub>PD</sub>
I <sub>OL</sub>	$\overline{\text{LED}}$ , CC sink	10	-	-	mA	@V <sub>OL</sub> = V <sub>SS</sub> + 0.8V
I <sub>L</sub>	Input leakage	-	-	±1	μA	INH, CC, V = V <sub>SS</sub> to V <sub>CC</sub>
I <sub>OZ</sub>	Output leakage in high-Z state	-5	-	-	μA	$\overline{\text{LED}}$ , CC

**Note:** All voltages relative to V<sub>SS</sub>.

**Impedance**

Symbol	Parameter	Minimum	Typical	Maximum	Unit
R <sub>BAT</sub>	Battery input impedance	50	-	-	MΩ
R <sub>TS</sub>	TS input impedance	50	-	-	MΩ

**Timing** (T<sub>A</sub> = 0 to +70°C; V<sub>CC</sub> ±10%)

Symbol	Parameter	Minimum	Typical	Maximum	Unit	Notes
d <sub>FCV</sub>	Time base variation	-12	-	12	%	
t <sub>DLY</sub>	Start-up delay	0.35	-	0.9	s	Starting from V <sub>MCV</sub> < V <sub>BAT</sub> < V <sub>PD</sub>

**Note:** Typical is at T<sub>A</sub> = 25°C, V<sub>CC</sub> = 5.0V.

# bq2002E/G

## 8-Pin DIP (PN)

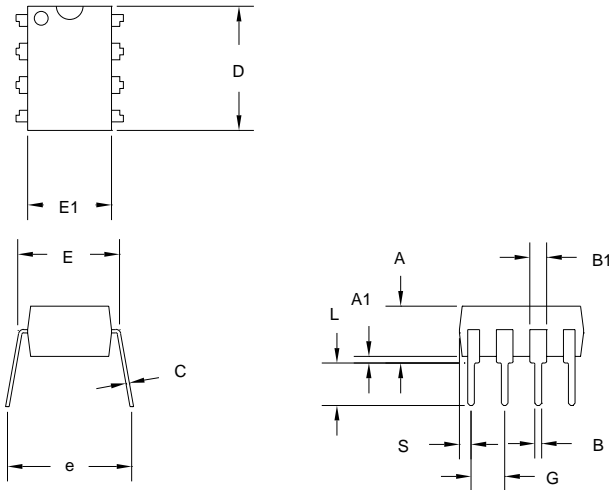

### 8-Pin PN (0.300" DIP)

Dimension	Inches		Millimeters	
	Min.	Max.	Min.	Max.
A	0.160	0.180	4.06	4.57
A1	0.015	0.040	0.38	1.02
B	0.015	0.022	0.38	0.56
B1	0.055	0.065	1.40	1.65
C	0.008	0.013	0.20	0.33
D	0.350	0.380	8.89	9.65
E	0.300	0.325	7.62	8.26
E1	0.230	0.280	5.84	7.11
e	0.300	0.370	7.62	9.40
G	0.090	0.110	2.29	2.79
L	0.115	0.150	2.92	3.81
S	0.020	0.040	0.51	1.02

## 8-Pin SOIC Narrow (SN)

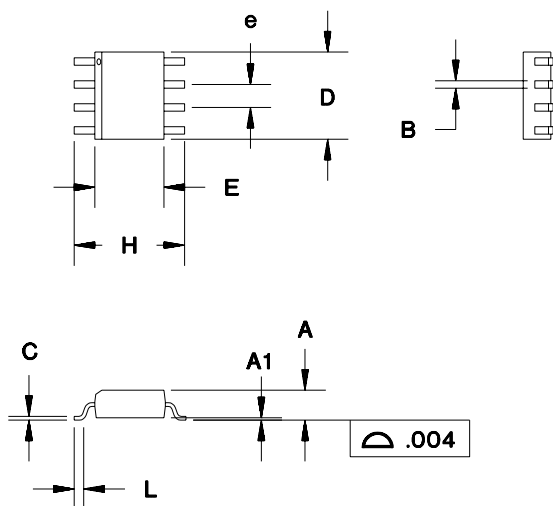

### 8-Pin SN (0.150" SOIC)

Dimension	Inches		Millimeters	
	Min.	Max.	Min.	Max.
A	0.060	0.070	1.52	1.78
A1	0.004	0.010	0.10	0.25
B	0.013	0.020	0.33	0.51
C	0.007	0.010	0.18	0.25
D	0.185	0.200	4.70	5.08
E	0.150	0.160	3.81	4.06
e	0.045	0.055	1.14	1.40
H	0.225	0.245	5.72	6.22
L	0.015	0.035	0.38	0.89

**PACKAGING INFORMATION**

Orderable Device	Status (1)	Package Type	Package Drawing	Pins	Package Qty	Eco Plan (2)	Lead/Ball Finish (6)	MSL Peak Temp (3)	Op Temp (°C)	Device Marking (4/5)	Samples
BQ2002EPN	ACTIVE	PDIP	P	8	50	Green (RoHS & no Sb/Br)	CU NIPDAU	N / A for Pkg Type	0 to 70	2002EPN	<a href="#">Samples</a>
BQ2002ESN	ACTIVE	SOIC	D	8	75	Green (RoHS & no Sb/Br)	CU NIPDAU	Level-1-260C-UNLIM	0 to 70	2002E	<a href="#">Samples</a>
BQ2002ESNTR	ACTIVE	SOIC	D	8	2500	Green (RoHS & no Sb/Br)	CU NIPDAU	Level-1-260C-UNLIM	0 to 70	2002E	<a href="#">Samples</a>
BQ2002GPN	ACTIVE	PDIP	P	8	50	Green (RoHS & no Sb/Br)	CU NIPDAU	N / A for Pkg Type	0 to 70	2002GPN	<a href="#">Samples</a>
BQ2002GSN	ACTIVE	SOIC	D	8	75	Green (RoHS & no Sb/Br)	CU NIPDAU	Level-1-260C-UNLIM	0 to 70	2002G	<a href="#">Samples</a>

(1) The marketing status values are defined as follows:

**ACTIVE:** Product device recommended for new designs.

**LIFEBUY:** TI has announced that the device will be discontinued, and a lifetime-buy period is in effect.

**NRND:** Not recommended for new designs. Device is in production to support existing customers, but TI does not recommend using this part in a new design.

**PREVIEW:** Device has been announced but is not in production. Samples may or may not be available.

**OBSELETE:** TI has discontinued the production of the device.

(2) **RoHS:** TI defines "RoHS" to mean semiconductor products that are compliant with the current EU RoHS requirements for all 10 RoHS substances, including the requirement that RoHS substance do not exceed 0.1% by weight in homogeneous materials. Where designed to be soldered at high temperatures, "RoHS" products are suitable for use in specified lead-free processes. TI may reference these types of products as "Pb-Free".

**RoHS Exempt:** TI defines "RoHS Exempt" to mean products that contain lead but are compliant with EU RoHS pursuant to a specific EU RoHS exemption.

**Green:** TI defines "Green" to mean the content of Chlorine (Cl) and Bromine (Br) based flame retardants meet JS709B low halogen requirements of <=1000ppm threshold. Antimony trioxide based flame retardants must also meet the <=1000ppm threshold requirement.

(3) MSL, Peak Temp. - The Moisture Sensitivity Level rating according to the JEDEC industry standard classifications, and peak solder temperature.

(4) There may be additional marking, which relates to the logo, the lot trace code information, or the environmental category on the device.

(5) Multiple Device Markings will be inside parentheses. Only one Device Marking contained in parentheses and separated by a "-" will appear on a device. If a line is indented then it is a continuation of the previous line and the two combined represent the entire Device Marking for that device.

(6) Lead/Ball Finish - Orderable Devices may have multiple material finish options. Finish options are separated by a vertical ruled line. Lead/Ball Finish values may wrap to two lines if the finish value exceeds the maximum column width.

**Important Information and Disclaimer:**The information provided on this page represents TI's knowledge and belief as of the date that it is provided. TI bases its knowledge and belief on information provided by third parties, and makes no representation or warranty as to the accuracy of such information. Efforts are underway to better integrate information from third parties. TI has taken and continues to take reasonable steps to provide representative and accurate information but may not have conducted destructive testing or chemical analysis on incoming materials and chemicals. TI and TI suppliers consider certain information to be proprietary, and thus CAS numbers and other limited information may not be available for release.

In no event shall TI's liability arising out of such information exceed the total purchase price of the TI part(s) at issue in this document sold by TI to Customer on an annual basis.

## TAPE AND REEL INFORMATION



### QUADRANT ASSIGNMENTS FOR PIN 1 ORIENTATION IN TAPE



\*All dimensions are nominal

Device	Package Type	Package Drawing	Pins	SPQ	Reel Diameter (mm)	Reel Width W1 (mm)	A0 (mm)	B0 (mm)	K0 (mm)	P1 (mm)	W (mm)	Pin1 Quadrant
BQ2002ESNTR	SOIC	D	8	2500	330.0	12.4	6.4	5.2	2.1	8.0	12.0	Q1

TAPE AND REEL BOX DIMENSIONS



\*All dimensions are nominal

Device	Package Type	Package Drawing	Pins	SPQ	Length (mm)	Width (mm)	Height (mm)
BQ2002ESNTR	SOIC	D	8	2500	340.5	338.1	20.6



D0008A

# PACKAGE OUTLINE

SOIC - 1.75 mm max height

SMALL OUTLINE INTEGRATED CIRCUIT



4214825/C 02/2019

NOTES:

1. Linear dimensions are in inches [millimeters]. Dimensions in parenthesis are for reference only. Controlling dimensions are in inches. Dimensioning and tolerancing per ASME Y14.5M.
2. This drawing is subject to change without notice.
3. This dimension does not include mold flash, protrusions, or gate burrs. Mold flash, protrusions, or gate burrs shall not exceed  $.006$  [0.15] per side.
4. This dimension does not include interlead flash.
5. Reference JEDEC registration MS-012, variation AA.

# EXAMPLE BOARD LAYOUT

D0008A

SOIC - 1.75 mm max height

SMALL OUTLINE INTEGRATED CIRCUIT



LAND PATTERN EXAMPLE  
 EXPOSED METAL SHOWN  
 SCALE:8X



SOLDER MASK DETAILS

4214825/C 02/2019

NOTES: (continued)

- 6. Publication IPC-7351 may have alternate designs.
- 7. Solder mask tolerances between and around signal pads can vary based on board fabrication site.

# EXAMPLE STENCIL DESIGN

D0008A

SOIC - 1.75 mm max height

SMALL OUTLINE INTEGRATED CIRCUIT



SOLDER PASTE EXAMPLE  
BASED ON .005 INCH [0.125 MM] THICK STENCIL  
SCALE:8X

4214825/C 02/2019

NOTES: (continued)

8. Laser cutting apertures with trapezoidal walls and rounded corners may offer better paste release. IPC-7525 may have alternate design recommendations.
9. Board assembly site may have different recommendations for stencil design.



## IMPORTANT NOTICE AND DISCLAIMER

TI PROVIDES TECHNICAL AND RELIABILITY DATA (INCLUDING DATASHEETS), DESIGN RESOURCES (INCLUDING REFERENCE DESIGNS), APPLICATION OR OTHER DESIGN ADVICE, WEB TOOLS, SAFETY INFORMATION, AND OTHER RESOURCES "AS IS" AND WITH ALL FAULTS, AND DISCLAIMS ALL WARRANTIES, EXPRESS AND IMPLIED, INCLUDING WITHOUT LIMITATION ANY IMPLIED WARRANTIES OF MERCHANTABILITY, FITNESS FOR A PARTICULAR PURPOSE OR NON-INFRINGEMENT OF THIRD PARTY INTELLECTUAL PROPERTY RIGHTS.

These resources are intended for skilled developers designing with TI products. You are solely responsible for (1) selecting the appropriate TI products for your application, (2) designing, validating and testing your application, and (3) ensuring your application meets applicable standards, and any other safety, security, or other requirements. These resources are subject to change without notice. TI grants you permission to use these resources only for development of an application that uses the TI products described in the resource. Other reproduction and display of these resources is prohibited. No license is granted to any other TI intellectual property right or to any third party intellectual property right. TI disclaims responsibility for, and you will fully indemnify TI and its representatives against, any claims, damages, costs, losses, and liabilities arising out of your use of these resources.

TI's products are provided subject to TI's Terms of Sale ([www.ti.com/legal/termsofsale.html](http://www.ti.com/legal/termsofsale.html)) or other applicable terms available either on [ti.com](http://ti.com) or provided in conjunction with such TI products. TI's provision of these resources does not expand or otherwise alter TI's applicable warranties or warranty disclaimers for TI products.

Mailing Address: Texas Instruments, Post Office Box 655303, Dallas, Texas 75265  
Copyright © 2019, Texas Instruments Incorporated

## Looking for pricing, stock, or lifecycle information?

Click below to explore more details on WIN SOURCE:

 [View BQ2002EPN](#) on WIN SOURCE

 [Texas Instruments](#) Information

## Optimize Your Supply Chain with WIN SOURCE Solutions

-  Global Sourcing Solution
-  Obsolete Management
-  Cost Control Management
-  Shortage Management
-  Alternative Solution
-  Excess Inventory Management