



THE DATASHEET OF
1744426-6



OPAx837 Low-Power, Precision, 105-MHz, Voltage-Feedback Op Amp

1 Features

- Bandwidth: 105 MHz ($A_V = 1$ V/V)
- Very Low (Trimmed) Supply Current: 600 μ A
- Gain Bandwidth Product: 50 MHz
- Slew Rate: 105 V/ μ s
- Negative Rail Input, Rail-to-Rail Output
- Single-Supply Operating Range: 2.7 V to 5.4 V
- 25°C Input Offset: ± 130 μ V (Max)
- Input Offset Voltage Drift (DCK Package): $< \pm 1.6$ μ V/ $^{\circ}$ C (Maximum)
- Input Voltage Noise: 4.7 nV/ $\sqrt{\text{Hz}}$ (> 100 Hz)
- HD2: -120 dBc at 2 V_{PP} , 100 kHz
- HD3: -145 dBc at 2 V_{PP} , 100 kHz
- Settling Time: 35 ns, 0.5-V Step to 0.1%
- 5- μ A Shutdown Current With Fast Recovery From Shutdown for Power Scaling Applications

2 Applications

- 12-Bit to 16-Bit, Low-Power SAR Drivers
- Precision ADC Reference Buffers
- Very-Low-Power Active Filters
- Low-Power Transimpedance Amplifiers
- Sensor Signal Conditioning
- Wearable Devices
- Low-Side Current Sensing

Low-Power, Low-Noise, Precision, Single-Ended SAR ADC Driver With True Ground Input and Output Range

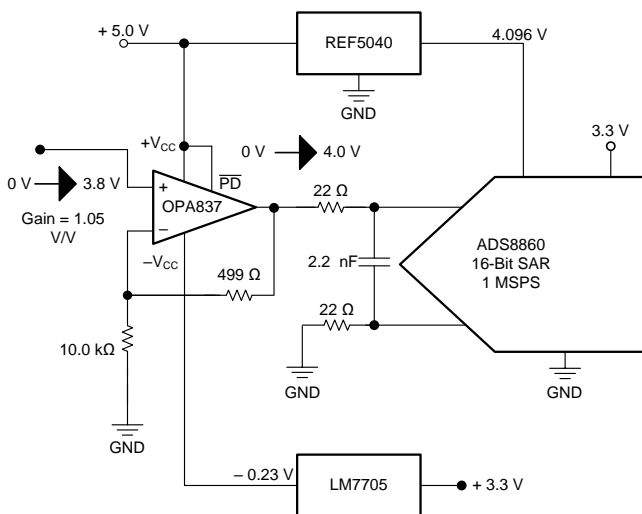

3 Description

The OPA837 and OPA2837 are single- and dual-channel unity-gain stable, voltage-feedback amplifiers that provide among the highest MHz per mW of bandwidth versus power among precision op amps. Using only 600 μ A per channel on a single 5-V supply, these 3.0-mW devices deliver 105-MHz bandwidth at a gain of 1 V/V. The very low trimmed offset voltage of ± 130 μ V (maximum) comes with a typical ($\pm 1\sigma$) drift of ± 0.4 μ V/ $^{\circ}$ C.

Ideally suited to single-ended, successive-approximation register (SAR) analog-to-digital-converter (ADC) driving applications, the OPAx837 provides one of the lowest input spot noise levels at 4.7 nV/ $\sqrt{\text{Hz}}$ for the 3-mW quiescent power. The very high 50-MHz gain bandwidth product provides the low output impedance to high frequencies required to supply the fast charging currents in SAR ADC driver applications. This low dynamic output impedance is also suitable for reference buffer applications with precision ADCs. The single-channel OPA837 is available in a 6-pin SOT-23 package (that includes a power shutdown feature) and a 5-pin SC70 package whereas the dual-channel OPA2837 is available in an 8-pin VSSOP package and a 10-pin WQFN package.

The OPAx837 is characterized for operation over the a wide temperature range of -40°C to $+125^{\circ}\text{C}$.

Device Information⁽¹⁾

PART NUMBER	PACKAGE	BODY SIZE (NOM)
OPA837	SOT-23 (6)	2.90 mm x 1.60 mm
	SC70 (5)	2.00 mm x 1.25 mm
OPA2837	VSSOP (8)	3.00 mm x 3.00 mm
	WQFN (10)	2.00 mm x 2.00 mm

(1) For all available packages, see the package option addendum at the end of the data sheet.



Table of Contents

1 Features	1	7.3 Feature Description	23
2 Applications	1	7.4 Device Functional Modes	26
3 Description	1	8 Application and Implementation	30
4 Revision History	2	8.1 Application Information	30
5 Pin Configuration and Functions	4	8.2 Typical Applications	39
6 Specifications	5	9 Power Supply Recommendations	43
6.1 Absolute Maximum Ratings	5	10 Layout	43
6.2 ESD Ratings	5	10.1 Layout Guidelines	43
6.3 Recommended Operating Conditions	5	10.2 Layout Example	44
6.4 Thermal Information: OPA837	6	11 Device and Documentation Support	45
6.5 Thermal Information: OPA2837	6	11.1 Documentation Support	45
6.6 Electrical Characteristics: $V_S = 5\text{ V}$	7	11.2 Related Links	45
6.7 Electrical Characteristics: $V_S = 3\text{ V}$	9	11.3 Receiving Notification of Documentation Updates	45
6.8 Typical Characteristics: $V_S = 5.0\text{ V}$	11	11.4 Community Resources	45
6.9 Typical Characteristics: $V_S = 3.0\text{ V}$	14	11.5 Trademarks	45
6.10 Typical Characteristics: $\pm 2.5\text{-V}$ to $\pm 1.5\text{-V}$ Split Supply	17	11.6 Electrostatic Discharge Caution	45
7 Detailed Description	22	11.7 Glossary	46
7.1 Overview	22	12 Mechanical, Packaging, and Orderable Information	46
7.2 Functional Block Diagrams	22		

4 Revision History

NOTE: Page numbers for previous revisions may differ from page numbers in the current version.

Changes from Revision C (August 2018) to Revision D	Page
• Added reference to WQFN (RUN) package in <i>Description</i> section	1
• Added OPA2837 RUN package thermal information to document.	6
• Changed values of maximum and minimum input-referred offset voltage at 25°C and across temperature in 5 V and 3 V Electrical Characteristics tables.	7
• Changed value of maximum input offset current drift for OPA2837 in 5 V and 3 V Electrical Characteristics tables.	8
• Changed minimum value of CMRR in 5 V Electrical Characteristics table	8
• Added reference to TIDA-01565 reference design in <i>Power-Down Operation</i> section	24
• Added reference to TIDA-01565 reference design in <i>1-Bit PGA Operation</i> section	42

Changes from Revision B (July 2018) to Revision C	Page
• Added OPA2837 RUN package to document	1

Changes from Revision A (April 2018) to Revision B	Page
• Changed input common-mode impedance in 5V and 3V electrical characteristics tables	8

Changes from Original (September 2017) to Revision A	Page
• Added OPA2837 to document	1
• Added <i>Single-Supply Operating Range</i> Features bullet	1
• Changed 1 SPS to 1 MSPS in front page figure	1
• Added footnote to <i>Pin Functions</i> table	4
• Changed footnote describing method of computation of slew rate in Electrical Characteristics: $V_S = 5\text{ V}$ table	7

- Changed default test condition in Electrical Characteristics: $V_S = 3\text{ V}$ table 9
- Changed footnote describing method of computation of slew rate in Electrical Characteristics: $V_S = 3\text{ V}$ table 9
- Changed values for common-mode input range, high in Electrical Characteristics: $V_S = 3\text{ V}$ table 10
- Changed values for V_{OH} in Electrical Characteristics: $V_S = 3\text{ V}$ table 10
- Changed $V_O = 20\text{ mV}_{PP}$ to $V_{OUT} = 200\text{ mV}_{PP}$ in conditions of *Noninverting Response Flatness vs Gain* and *Inverting Response Flatness vs Gain* figures..... 11
- Changed *gain* -1 V/V to *gain* -2 V/V , swapped legend colors in *Inverting Overdrive Recovery* figure..... 12
- Changed $V_{OUT} = 2\text{ V}_{PP}$ to $V_{OUT} = 1\text{ V}_{PP}$ in conditions of *Typical Characteristics: $V_S = 3.0\text{ V}$* section 14
- Changed $V_O = 20\text{ mV}_{PP}$ to $V_{OUT} = 200\text{ mV}_{PP}$ in *Noninverting Response Flatness vs Gain* and *Inverting Response Flatness vs Gain* figure conditions..... 14
- Changed V_{IN} to $V_{IN} \times -1$ *gain*, swapped legend colors in *Inverting Overdrive Recovery* figure 15
- Changed $V_O = 2\text{ V}_{PP}$ to $V_{OUT} = 1\text{ V}_{PP}$ in *Harmonic Distortion vs R_{LOAD}* figure conditions..... 16
- Changed $V_{OUT} = 2\text{ V}_{PP}$ to $V_{OUT} = 1\text{ V}_{PP}$ in *Harmonic Distortion vs Gain Magnitude* figure conditions 16
- Changed y-axis caption in *Turn-On Time to Sinusoidal Input* and *Turn-Off Time to Sinusoidal Input* figures..... 19
- Added OPA838 row to *Device Family Comparison* table..... 23
- Changed EVM link in *Split-Supply Operation* section from *OPA837DBV* to *OPA835DBV*..... 26
- Changed V2 value from 2.5 V to -2.5 V in *Characterization Test Circuit for Network, Spectrum Analyzer* figure 30
- Changed V_{EE} value from 2.5 V to -2.5 V in *Inverting Characterization Circuit for Network Analyzer* figure 32
- Changed *1 SPS* to *1 MSPS* in *OPA837 and ADS8860 Example Circuit* figure 38

5 Pin Configuration and Functions

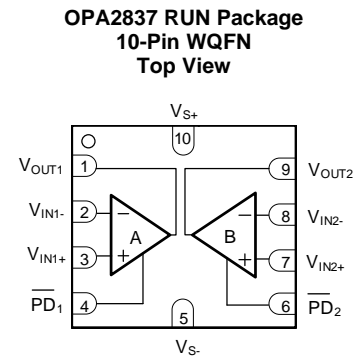
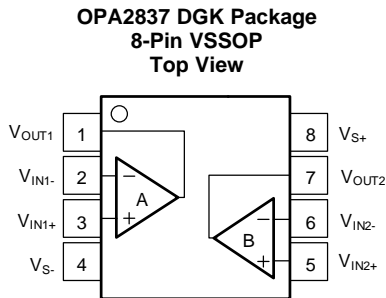
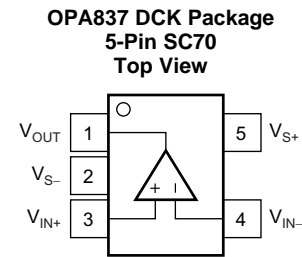
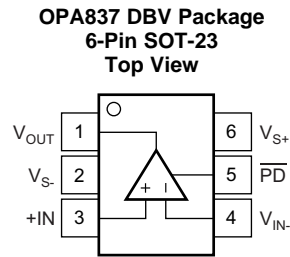

Pin Functions

NAME	PIN				FUNCTION ⁽¹⁾	DESCRIPTION
	OPA837		OPA2837			
	SOT-23	SC-70	VSSOP	WQFN		
$\overline{\text{PD}}$	5	—	—	—	I	Amplifier power down. Low = disabled, high = normal operation (pin must be driven).
$\overline{\text{PD}}_1$	—	—	—	4	I	Amplifier 1 power down. Low = disabled, high = normal operation (pin must be driven).
$\overline{\text{PD}}_2$	—	—	—	6	I	Amplifier 2 power down. Low = disabled, high = normal operation (pin must be driven).
$V_{\text{IN}-}$	4	4	—	—	I	Inverting input pin
$V_{\text{IN}+}$	3	3	—	—	I	Noninverting input pin
$V_{\text{IN}1-}$	—	—	2	2	I	Amplifier 1 inverting input pin
$V_{\text{IN}1+}$	—	—	3	3	I	Amplifier 1 noninverting input pin
$V_{\text{IN}2-}$	—	—	6	8	I	Amplifier 2 inverting input pin
$V_{\text{IN}2+}$	—	—	5	7	I	Amplifier 2 noninverting input pin
V_{OUT}	1	1	—	—	O	Output pin
$V_{\text{OUT}1}$	—	—	1	1	O	Amplifier 1 output pin
$V_{\text{OUT}2}$	—	—	7	9	O	Amplifier 2 output pin
$V_{\text{S}-}$	2	2	4	5	P	Negative power-supply pin
$V_{\text{S}+}$	6	5	8	10	P	Positive power-supply input

(1) I = input, O = output, and P = power.

6 Specifications

6.1 Absolute Maximum Ratings

over operating free-air temperature range (unless otherwise noted)⁽¹⁾

		MIN	MAX	UNIT
V _{S-} to V _{S+}	Supply voltage		5.5	V
	Supply turn-on/off maximum dV/dT ⁽²⁾		1	V/μs
V _I	Input voltage	V _{S-} – 0.5	V _{S+} + 0.5	V
V _{ID}	Differential input voltage		±1	V
I _I	Continuous input current		±10	mA
I _O	Continuous output current ⁽³⁾		±20	mA
	Continuous power dissipation	See Thermal Information: OPA837		
T _J	Maximum junction temperature		150	°C
T _A	Operating free-air temperature	–40	125	°C
T _{stg}	Storage temperature	–65	150	°C

- (1) Stresses beyond those listed under *Absolute Maximum Ratings* may cause permanent damage to the device. These are stress ratings only, which do not imply functional operation of the device at these or any other conditions beyond those indicated under *Recommended Operating Conditions*. Exposure to absolute-maximum-rated conditions for extended periods may affect device reliability.
- (2) Staying below this ± supply turn-on edge rate prevents the edge-triggered ESD absorption device across the supply pins from turning on.
- (3) Long-term continuous output current for electromigration limits.

6.2 ESD Ratings

			VALUE	UNIT
V _(ESD)	Electrostatic discharge	Human body model (HBM), per ANSI/ESDA/JEDEC JS-001 ⁽¹⁾	±1500	V
		Charged-device model (CDM), per JEDEC specification JESD22-C101 ⁽²⁾	±1000	

- (1) JEDEC document JEP155 states that 500-V HBM allows safe manufacturing with a standard ESD control process.
- (2) JEDEC document JEP157 states that 250-V CDM allows safe manufacturing with a standard ESD control process.

6.3 Recommended Operating Conditions

over operating free-air temperature range (unless otherwise noted)

		MIN	NOM	MAX	UNIT
V _{S+}	Single-supply voltage	2.7	5	5.4	V
T _A	Ambient temperature	–40	25	125	°C

6.4 Thermal Information: OPA837

THERMAL METRIC ⁽¹⁾		OPA837		UNIT
		DBV (SOT23-6)	DCK (SC70)	
		6 PINS	5 PINS	
$R_{\theta JA}$	Junction-to-ambient thermal resistance	194	203	°C/W
$R_{\theta JCtop}$	Junction-to-case (top) thermal resistance	129	152	°C/W
$R_{\theta JB}$	Junction-to-board thermal resistance	39	76	°C/W
Ψ_{JT}	Junction-to-top characterization parameter	26	58	°C/W
Ψ_{JB}	Junction-to-board characterization parameter	39	76	°C/W

(1) For more information about traditional and new thermal metrics, see the [Semiconductor and IC Package Thermal Metrics](#) application report.

6.5 Thermal Information: OPA2837

THERMAL METRIC ⁽¹⁾		OPA2837		UNIT
		RUN (WQFN-10)	DGK (VSSOP-8)	
		10 PINS	8 PINS	
$R_{\theta JA}$	Junction-to-ambient thermal resistance	124.9	182	°C/W
$R_{\theta JCtop}$	Junction-to-case (top) thermal resistance	72.0	63.5	°C/W
$R_{\theta JB}$	Junction-to-board thermal resistance	63.2	103.6	°C/W
Ψ_{JT}	Junction-to-top characterization parameter	4.3	7.9	°C/W
Ψ_{JB}	Junction-to-board characterization parameter	63.0	101.8	°C/W

(1) For more information about traditional and new thermal metrics, see the [Semiconductor and IC Package Thermal Metrics](#) application report.

6.6 Electrical Characteristics: $V_S = 5\text{ V}$

at $V_{S+} = 5\text{ V}$, $V_{S-} = 0\text{ V}$, $R_F = 0\ \Omega$, $R_L = 2\text{ k}\Omega$, $G = 1\text{ V/V}$, input and output referenced to mid-supply, and $T_A \approx 25^\circ\text{C}$ (unless otherwise noted)

PARAMETER		TEST CONDITIONS	MIN	TYP	MAX	UNIT	TEST LEVEL ⁽¹⁾
AC PERFORMANCE							
SSBW	Small-signal bandwidth	$V_{OUT} = 20\text{ mV}_{PP}$, $G = 1$	90	105		MHz	C
		$V_{OUT} = 20\text{ mV}_{PP}$, $G = 2$		45			C
		$V_{OUT} = 20\text{ mV}_{PP}$, $G = 10$		5			C
GBP	Gain-bandwidth product	$V_{OUT} = 20\text{ mV}_{PP}$, $G = 10$	45	50		MHz	C
LSBW	Large-signal bandwidth	$V_{OUT} = 2\text{ V}_{PP}$, $G = 2$		26		MHz	C
		Bandwidth for 0.1-dB flatness	$V_{OUT} = 200\text{ mV}_{PP}$, $G = 2$		6		MHz
SR	Slew rate	From LSBW ⁽²⁾		105		V/ μs	C
t_R , t_F	Rise, fall time	$V_{OUT} = 0.5\text{-V}$ step, $G = 2$, input $t_R = 10\text{ ns}$		10	11	ns	C
	Overshoot	$V_{OUT} = 2\text{-V}$ step, $G = 2$, input $t_R = 40\text{ ns}$		7.0%			C
	Settling time to 0.1%	$V_{OUT} = 2.0\text{-V}$ step, $G = 1$, input $t_R = 4\text{ ns}$		25		ns	C
	Settling time to 0.01%	$V_{OUT} = 2.0\text{-V}$ step, $G = 1$, input $t_R = 4\text{ ns}$		40		ns	C
HD2	Second-order harmonic distortion	$f = 100\text{ kHz}$, $V_O = 2\text{ V}_{PP}$, $G = 1$ (see Figure 73)		-120		dBc	C
HD3	Third-order harmonic distortion	$f = 100\text{ kHz}$, $V_O = 2\text{ V}_{PP}$, $G = 1$ (see Figure 73)		-145		dBc	C
	Input voltage noise	$f = 500\text{ Hz}$		4.7		nV/ $\sqrt{\text{Hz}}$	C
	Voltage noise 1/f corner frequency	See Figure 39		35		Hz	C
	Input current noise	$f = 20\text{ kHz}$		0.4		pA/ $\sqrt{\text{Hz}}$	C
	Current noise 1/f corner frequency	See Figure 39		5		kHz	C
	Overdrive recovery time	$G = 2$, 2x output overdrive (see Figure 30)		75		ns	C
	Closed-loop output impedance	$f = 1\text{ MHz}$, $G = 1$ (see Figure 38)		0.14		Ω	C
	Channel-to-channel crosstalk (OPA2837)	$f = 10\text{ kHz}$		-126		dBc	C
DC PERFORMANCE							
A_{OL}	Open-loop voltage gain	$V_O = \pm 2\text{ V}$, $R_L = 2\text{ k}\Omega$	120	135		dB	A
	Input-referred offset voltage	$T_A \approx 25^\circ\text{C}$	-165	± 30	165	μV	A
		$T_A = 0^\circ\text{C}$ to $+70^\circ\text{C}$ (DCK package)	-205	± 30	235		B
		$T_A = -40^\circ\text{C}$ to $+85^\circ\text{C}$ (DCK package)	-269	± 30	261		B
		$T_A = -40^\circ\text{C}$ to $+125^\circ\text{C}$ (DCK package)	-269	± 30	325		B
	Input offset voltage drift ⁽³⁾	DCK package, $T_A = -40^\circ\text{C}$ to $+125^\circ\text{C}$	-1.6	± 0.4	1.6	$\mu\text{V}/^\circ\text{C}$	B
		DBV, RUN package, $T_A = -40^\circ\text{C}$ to $+125^\circ\text{C}$	-2.0	± 0.4	2.0		B
		DGK package, $T_A = -40^\circ\text{C}$ to $+125^\circ\text{C}$		± 0.67			B
	Input bias current ⁽⁴⁾	$T_A \approx 25^\circ\text{C}$	150	340	520	nA	A
		$T_A = 0^\circ\text{C}$ to $+70^\circ\text{C}$	50	340	664		B
		$T_A = -40^\circ\text{C}$ to $+85^\circ\text{C}$	50	340	718		B
		$T_A = -40^\circ\text{C}$ to $+125^\circ\text{C}$	50	340	850		B
	Input bias current drift ⁽³⁾	$T_A = -40^\circ\text{C}$ to $+125^\circ\text{C}$	0.8	1.5	3.3	nA/ $^\circ\text{C}$	B
	Input offset current	$T_A \approx 25^\circ\text{C}$ (OPA837)	-40	± 6	40	nA	A
		$T_A = 0^\circ\text{C}$ to $+70^\circ\text{C}$	-46	± 6	52		B
		$T_A = -40^\circ\text{C}$ to $+85^\circ\text{C}$	-56	± 6	55		B
		$T_A = -40^\circ\text{C}$ to $+125^\circ\text{C}$	-56	± 6	65		B
		$T_A \approx 25^\circ\text{C}$ (OPA2837)	-60	± 8	60		A

(1) Test levels (all values set by characterization and simulation): (A) 100% tested at 25°C , overtemperature limits by characterization and simulation; (B) Not tested in production, limits set by characterization and simulation; (C) Typical value only for information.

(2) This slew rate is the average of the rising and falling time estimated from the large-signal bandwidth as: $(0.8 \times V_{PEAK} / \sqrt{2}) \times 2\pi \times f_{-3dB}$ where this f_{-3dB} is the typical measured 2-V_{PP} bandwidth at gains of 1 V/V.

(3) Input offset voltage drift, input bias current drift, and input offset current drift are average values calculated by taking data at the end points, computing the difference, and dividing by the temperature range. Typical drift specifications are $\pm 1\sigma$. Maximum drift specifications are set by min/max sample packaged test data using a wafer-level screened drift. Min/Max drift is not specified by final automated test equipment (ATE) nor by QA sample testing.

(4) Current is considered positive out of the pin.

Electrical Characteristics: $V_S = 5\text{ V}$ (continued)

 at $V_{S+} = 5\text{ V}$, $V_{S-} = 0\text{ V}$, $R_F = 0\ \Omega$, $R_L = 2\text{ k}\Omega$, $G = 1\text{ V/V}$, input and output referenced to mid-supply, and $T_A \approx 25^\circ\text{C}$ (unless otherwise noted)

PARAMETER		TEST CONDITIONS	MIN	TYP	MAX	UNIT	TEST LEVEL ⁽¹⁾
	Input offset current drift ⁽³⁾	$T_A = -40^\circ\text{C}$ to $+125^\circ\text{C}$	-250	± 40	250	$\mu\text{A}/^\circ\text{C}$	B
		$T_A = -40^\circ\text{C}$ to $+125^\circ\text{C}$ (OPA2837)	-270	± 80	330		B
	Input-referred offset voltage mismatch	$T_A \approx 25^\circ\text{C}$ (OPA2837)	-220	50	220	μV	A
INPUT							
	Common-mode input range, low	$T_A \approx 25^\circ\text{C}$, < 3-dB degradation in CMRR limit		-0.2	0	V	A
		$T_A = -40^\circ\text{C}$ to $+125^\circ\text{C}$, < 3-dB degradation in CMRR limit		-0.2	0		B
	Common-mode input range, high	$T_A \approx 25^\circ\text{C}$, < 3-dB degradation in CMRR limit	3.7	3.8		V	A
		$T_A = -40^\circ\text{C}$ to $+125^\circ\text{C}$, < 3-dB degradation in CMRR limit	3.7	3.8			B
CMRR	Common-mode rejection ratio		91	110		dB	A
	Input impedance common-mode			$175 \parallel 1.5$		$\text{M}\Omega \parallel \text{pF}$	C
	Input impedance differential mode			$180 \parallel 0.5$		$\text{k}\Omega \parallel \text{pF}$	C
OUTPUT							
V_{OL}	Output voltage, low	$T_A \approx 25^\circ\text{C}$, $G = 2$		0.05	0.1	V	A
		$T_A = -40^\circ\text{C}$ to $+125^\circ\text{C}$, $G = 5$		0.05	0.1		B
V_{OH}	Output voltage, high	$T_A \approx 25^\circ\text{C}$, $G = 2$	4.9	4.95		V	A
		$T_A = -40^\circ\text{C}$ to $+125^\circ\text{C}$, $G = 5$	4.8	4.9			B
	Maximum current into a resistive load	$T_A \approx 25^\circ\text{C}$, $\pm 1.6\text{ V}$ into $27\ \Omega$, $V_{IO} < 2\text{ mV}$	± 58	± 70		mA	A
	Linear current into a resistive load	$T_A \approx 25^\circ\text{C}$, $\pm 1.7\text{ V}$ into $37.4\ \Omega$, $A_{OL} > 80\text{ dB}$	± 45	± 50		mA	A
	Linear current into a resistive load overtemperature	$T_A = -40^\circ\text{C}$ to $+125^\circ\text{C}$, $\pm 1.31\text{ V}$ into $37.4\ \Omega$, $A_{OL} > 80\text{ dB}$	± 35	± 45		mA	C
	Closed-loop output impedance	Gain of 1 V/V , $\pm 30\text{-mA DC}$		0.6		$\text{m}\Omega$	C
POWER SUPPLY							
	Specified operating voltage		2.7		5.4	V	B
	Quiescent operating current per amplifier (5-V supply)	$T_A \approx 25^\circ\text{C}$ ⁽⁵⁾	564	592	625	μA	A
		$T_A = -40^\circ\text{C}$ to $+125^\circ\text{C}$	408	592	865		B
	Supply current temperature coefficient per amplifier	$T_A = -40^\circ\text{C}$ to $+125^\circ\text{C}$ (see Figure 57)	1.1	1.9	2.4	$\mu\text{A}/^\circ\text{C}$	B
+PSRR	Positive power-supply rejection ratio		95	110		dB	A
-PSRR	Negative power-supply rejection ratio		92	108		dB	A
POWER DOWN (Pin Must be Driven)							
	Enable voltage threshold	Specified on above $V_{S-} + 1.5\text{ V}$			1.5	V	A
	Disable voltage threshold	Specified off below $V_{S-} + 0.55\text{ V}$	0.55			V	A
	Power-down pin bias current	$\overline{\text{PD}} = 0\text{ V}$ to V_{S+}	-50		50	nA	A
	Power-down quiescent current	$\overline{\text{PD}} \leq 0.55\text{ V}$	4	5	10	μA	A
	Power-down quiescent current over temperature	$\overline{\text{PD}} \leq 0.55\text{ V}$, $T_A = -40^\circ\text{C}$ to $+125^\circ\text{C}$			10	μA	B
	Turnon time delay	Time from $\overline{\text{PD}} = \text{high}$ to $V_{OUT} = 90\%$ of final value		300		ns	C
	Turnoff time delay	Time from $\overline{\text{PD}} = \text{low}$ to $V_{OUT} = 10\%$ of original value		100		ns	C

 (5) The typical specification is at 25°C T_J . The min, max limits are expanded for the automated test equipment (ATE) to account for an ambient range from 22°C to 32°C with a $2\text{-}\mu\text{A}/^\circ\text{C}$ temperature coefficient on the supply current.

6.7 Electrical Characteristics: $V_S = 3\text{ V}$

at $V_{S+} = 3\text{ V}$, $V_{S-} = 0\text{ V}$, $R_F = 0\ \Omega$, $R_L = 2\text{ k}\Omega$, $G = 1\text{ V/V}$, input and output referenced to mid-supply, and $T_A \approx 25^\circ\text{C}$ (unless otherwise noted)

PARAMETER		TEST CONDITIONS	MIN	TYP	MAX	UNIT	TEST LEVEL ⁽¹⁾
AC PERFORMANCE							
SSBW	Small-signal bandwidth	$V_{OUT} = 20\text{ mV}_{PP}$, $G = 1$	85	105		MHz	C
		$V_{OUT} = 20\text{ mV}_{PP}$, $G = 2$		45			C
		$V_{OUT} = 20\text{ mV}_{PP}$, $G = 10$		5			C
GBP	Gain-bandwidth product	$V_{OUT} = 20\text{ mV}_{PP}$, $G = 10$	40	50		MHz	C
LSBW	Large-signal bandwidth	$V_{OUT} = 1\text{ V}_{PP}$, $G = 2$		30		MHz	C
		Bandwidth for 0.1-dB flatness	$V_{OUT} = 200\text{ mV}_{PP}$, $G = 2$		6		MHz
SR	Slew rate	From LSBW ⁽²⁾		65		V/ μs	C
t_R , t_F	Rise, fall time	$V_{OUT} = 0.5\text{-V}$ step, $G = 2$, input $t_R = 10\text{ ns}$		10	11	ns	C
	Overshoot	$V_{OUT} = 2\text{-V}$ step, $G = 2$, input $t_R = 40\text{ ns}$		7%			C
	Settling time to 0.1%	$V_{OUT} = 0.5\text{-V}$ step, $G = 1$, input $t_R = 4\text{ ns}$		35		ns	C
	Settling time to 0.01%	$V_{OUT} = 0.5\text{-V}$ step, $G = 1$, input $t_R = 4\text{ ns}$		50		ns	C
HD2	Second-order harmonic distortion	$f = 100\text{ kHz}$, $V_O = 1\text{ V}_{PP}$, $G = 1$ (see Figure 73)		-125		dBc	C
HD3	Third-order harmonic distortion	$f = 100\text{ kHz}$, $V_O = 1\text{ V}_{PP}$, $G = 1$ (see Figure 73)		-138		dBc	C
	Input voltage noise	$f = 500\text{ Hz}$		4.9		nV/ $\sqrt{\text{Hz}}$	C
	Voltage noise 1/f corner frequency	See Figure 39		35		Hz	C
	Input current noise	$f = 10\text{ kHz}$		0.4		pA/ $\sqrt{\text{Hz}}$	C
	Current noise 1/f corner frequency	See Figure 39		5		kHz	C
	Overdrive recovery time	$G = 2$, 2x output overdrive (see Figure 29)		65		ns	C
	Closed-loop output impedance	$f = 1\text{ MHz}$, $G = 1$ (see Figure 38)		0.14		Ω	C
	Channel-to-channel crosstalk (OPA2837)	$f = 10\text{ kHz}$		-126		dBc	C
DC PERFORMANCE							
A_{OL}	Open-loop voltage gain	$V_O = \pm 1\text{ V}$, $R_L = 2\text{ k}\Omega$	120	133		dB	A
		$V_O = \pm 1\text{ V}$, $R_L = 2\text{ k}\Omega$ (OPA2837)	110	133			A
	Input-referred offset voltage	$T_A \approx 25^\circ\text{C}$	-165	± 30	165	μV	A
		$T_A = 0^\circ\text{C}$ to $+70^\circ\text{C}$	-205	± 30	235		B
		$T_A = -40^\circ\text{C}$ to $+85^\circ\text{C}$	-269	± 30	261		B
		$T_A = -40^\circ\text{C}$ to $+125^\circ\text{C}$	-269	± 30	325		B
	Input offset voltage drift ⁽³⁾	DCK package, $T_A = -40^\circ\text{C}$ to $+125^\circ\text{C}$	-1.6	± 0.4	1.6	$\mu\text{V}/^\circ\text{C}$	B
		DBV, RUN package, $T_A = -40^\circ\text{C}$ to $+125^\circ\text{C}$	-2.0	± 0.4	2.0		B
		DGK package, $T_A = -40^\circ\text{C}$ to $+125^\circ\text{C}$		± 0.67			B
	Input bias current ⁽⁴⁾	$T_A \approx 25^\circ\text{C}$	145	320	510	nA	A
		$T_A = 0^\circ\text{C}$ to $+70^\circ\text{C}$	50	320	659		B
		$T_A = -40^\circ\text{C}$ to $+85^\circ\text{C}$	50	320	708		B
		$T_A = -40^\circ\text{C}$ to $+125^\circ\text{C}$	50	320	840		B
	Input bias current drift ⁽³⁾	$T_A = -40^\circ\text{C}$ to $+125^\circ\text{C}$	0.8	1.5	3.3	nA/ $^\circ\text{C}$	B
	Input offset current	$T_A \approx 25^\circ\text{C}$ (OPA837)	-40	± 6	40	nA	A
		$T_A = 0^\circ\text{C}$ to $+70^\circ\text{C}$	-46	± 6	52		B
		$T_A = -40^\circ\text{C}$ to $+85^\circ\text{C}$	-56	± 6	55		B
		$T_A = -40^\circ\text{C}$ to $+125^\circ\text{C}$	-56	± 6	65		B
		$T_A \approx 25^\circ\text{C}$ (OPA2837)	-60	± 8	60		A

- (1) Test levels (all values set by characterization and simulation): (A) 100% tested at 25°C , overtemperature limits by characterization and simulation; (B) Not tested in production, limits set by characterization and simulation; (C) Typical value only for information.
- (2) This slew rate is the average of the rising and falling time estimated from the large-signal bandwidth as: $(0.8 \times V_{PEAK} / \sqrt{2}) \times 2\pi \times f_{-3dB}$ where this f_{-3dB} is the typical measured 2-Vpp bandwidth at gains of 1V/V.
- (3) Input offset voltage drift, input bias current drift, and input offset current drift are average values calculated by taking data at the end points, computing the difference, and dividing by the temperature range. Typical drift specifications are $\pm 1\sigma$. Maximum drift specifications are set by min/max sample packaged test data using a wafer-level screened drift. Min/Max drift is not specified by final automated test equipment (ATE) nor by QA sample testing.
- (4) Current is considered positive out of the pin.

Electrical Characteristics: $V_S = 3\text{ V}$ (continued)

at $V_{S+} = 3\text{ V}$, $V_{S-} = 0\text{ V}$, $R_F = 0\ \Omega$, $R_L = 2\text{ k}\Omega$, $G = 1\text{ V/V}$, input and output referenced to mid-supply, and $T_A \approx 25^\circ\text{C}$ (unless otherwise noted)

PARAMETER		TEST CONDITIONS	MIN	TYP	MAX	UNIT	TEST LEVEL ⁽¹⁾
	Input offset current drift ⁽³⁾	$T_A = -40^\circ\text{C}$ to $+125^\circ\text{C}$	-250	± 40	250	$\mu\text{A}/^\circ\text{C}$	B
		$T_A = -40^\circ\text{C}$ to $+125^\circ\text{C}$ (OPA2837)	-250	± 80	330		B
	Input-referred offset voltage mismatch	$T_A \approx 25^\circ\text{C}$ (OPA2837)	-220	50	220	μV	A
INPUT							
	Common-mode input range, low	$T_A \approx 25^\circ\text{C}$, < 3-dB degradation in CMRR limit		-0.2	0	V	A
		$T_A = -40^\circ\text{C}$ to $+125^\circ\text{C}$, < 3-dB degradation in CMRR limit		-0.2	0		B
	Common-mode input range, high	$T_A \approx 25^\circ\text{C}$, < 3-dB degradation in CMRR limit	1.7	1.8		V	A
		$T_A = -40^\circ\text{C}$ to $+125^\circ\text{C}$, < 3-dB degradation in CMRR limit	1.7	1.8			B
CMRR	Common-mode rejection ratio		90	105		dB	A
	Input impedance common-mode			$300 \parallel 1.5$		$\text{M}\Omega \parallel \text{pF}$	C
	Input impedance differential mode			$180 \parallel 0.5$		$\text{k}\Omega \parallel \text{pF}$	C
OUTPUT							
V_{OL}	Output voltage, low	$T_A \approx 25^\circ\text{C}$, $G = 2$		0.05	0.1	V	A
		$T_A = -40^\circ\text{C}$ to $+125^\circ\text{C}$, $G = 2$		0.10	0.2		B
V_{OH}	Output voltage, high	$T_A \approx 25^\circ\text{C}$, $G = 2$	2.9	2.95		V	A
		$T_A = -40^\circ\text{C}$ to $+125^\circ\text{C}$, $G = 2$	2.8	2.9			B
	Maximum current into a resistive load	$T_A \approx 25^\circ\text{C}$, $\pm 0.8\text{ V}$ into $17.5\ \Omega$, $V_{IO} < 2\text{ mV}$	± 45	± 55		mA	A
	Linear current into a resistive load	$T_A \approx 25^\circ\text{C}$, $\pm 0.9\text{ V}$ into $21.5\ \Omega$, $A_{OL} > 80\text{ dB}$	± 40	± 45		mA	A
	Linear current into a resistive load overtemperature	$T_A = -40^\circ\text{C}$ to 125°C , $\pm 0.7\text{ V}$ into $21.5\ \Omega$, $A_{OL} > 80\text{ dB}$	± 32	± 40		mA	C
POWER SUPPLY							
	Specified operating voltage		2.7		5.4	V	B
	Quiescent operating current per amplifier (OPA837, 3-V supply)	$T_A \approx 25^\circ\text{C}$ ⁽⁵⁾	547	570	607	μA	A
		$T_A = -40^\circ\text{C}$ to $+125^\circ\text{C}$	404	570	817		B
	Quiescent operating current per amplifier (OPA2837, 3-V supply)	$T_A \approx 25^\circ\text{C}$ ⁽⁵⁾	540	570	607	μA	A
	Supply current temperature coefficient per amplifier	$T_A = -40^\circ\text{C}$ to $+125^\circ\text{C}$ (see Figure 57)	0.8	1.7	2.2	$\mu\text{A}/^\circ\text{C}$	B
+PSRR	Positive power-supply rejection ratio		90	110		dB	A
-PSRR	Negative power-supply rejection ratio		88	105		dB	A
POWER DOWN (Pin Must be Driven)							
	Enable voltage threshold	Specified on above $V_{S-} + 1.5\text{ V}$			1.5	V	A
	Disable voltage threshold	Specified off below $V_{S-} + 0.55\text{ V}$	0.55			V	A
	Power-down pin bias current	$\overline{\text{PD}} = 0\text{ V}$ to V_{S+}	-50		50	nA	A
	Power-down quiescent current	$\overline{\text{PD}} \leq 0.55\text{ V}$	1	3	8	μA	A
	Power-down quiescent current over temperature	$\overline{\text{PD}} \leq 0.55\text{ V}$, $T_A = -40^\circ\text{C}$ to $+125^\circ\text{C}$			8	μA	B
	Turnon time delay	Time from $\overline{\text{PD}} = \text{high}$ to $V_{OUT} = 90\%$ of final value		300		ns	C
	Turnoff time delay	Time from $\overline{\text{PD}} = \text{low}$ to $V_{OUT} = 10\%$ of original value		100		ns	C

(5) The typical spec is at 25°C T_j . The min, max limits are expanded for ATE to account for ambient range from 22°C to 32°C with a $+4\text{-}\mu\text{A}/^\circ\text{C}$ temperature coefficient on the supply current.

6.8 Typical Characteristics: $V_S = 5.0\text{ V}$

at $V_{S+} = 5.0\text{ V}$, $V_{S-} = 0\text{ V}$, $V_{OUT} = 2\text{ V}_{PP}$, $R_F = 0\ \Omega$, $R_L = 2\text{ k}\Omega$, $G = 1\text{ V/V}$, input and output referenced to mid-supply, and $T_A \approx 25^\circ\text{C}$ (unless otherwise noted)

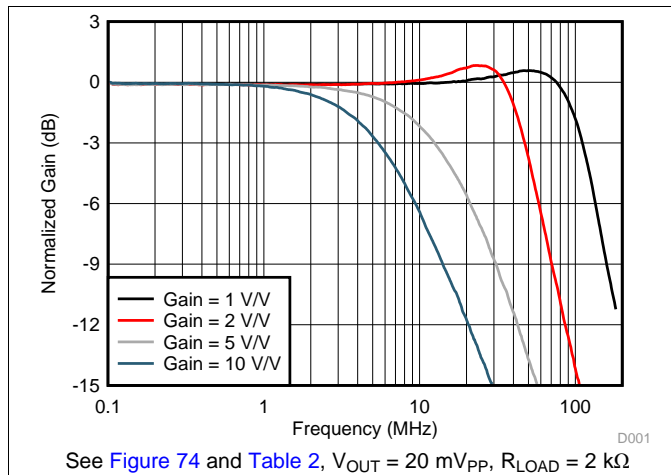

Figure 1. Noninverting Small-Signal Frequency Response vs Gain

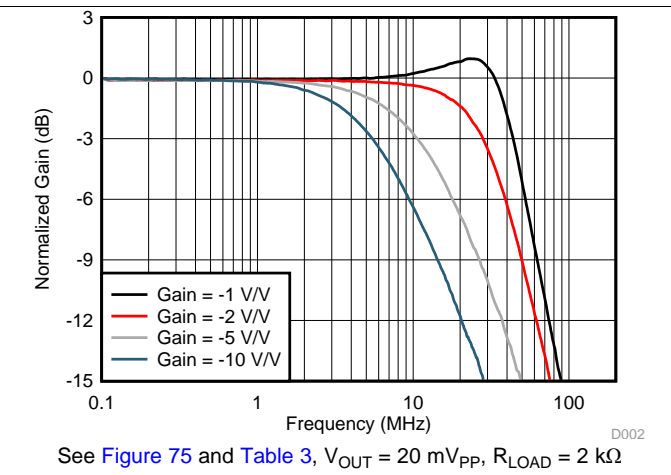

Figure 2. Inverting Small-Signal Frequency Response vs Gain

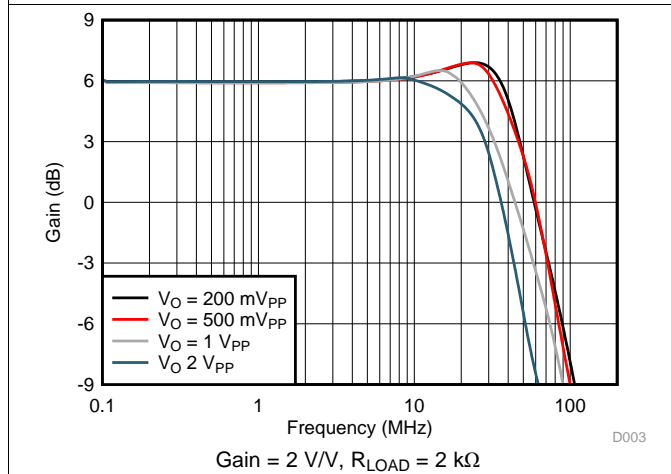

Figure 3. Noninverting Large-Signal Bandwidth vs V_{OPP}

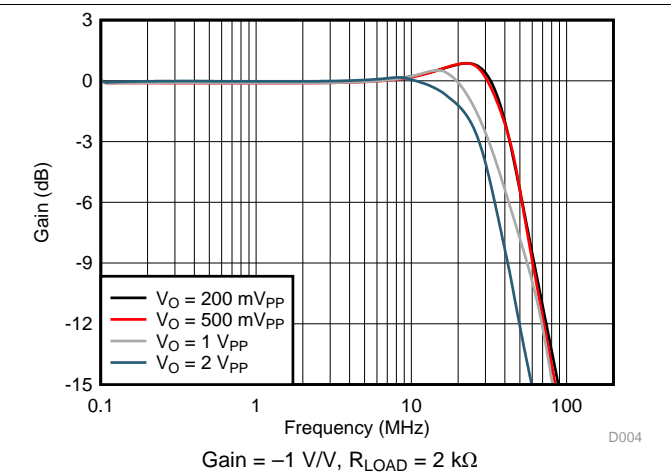

Figure 4. Inverting Large-Signal Bandwidth vs V_{OPP}

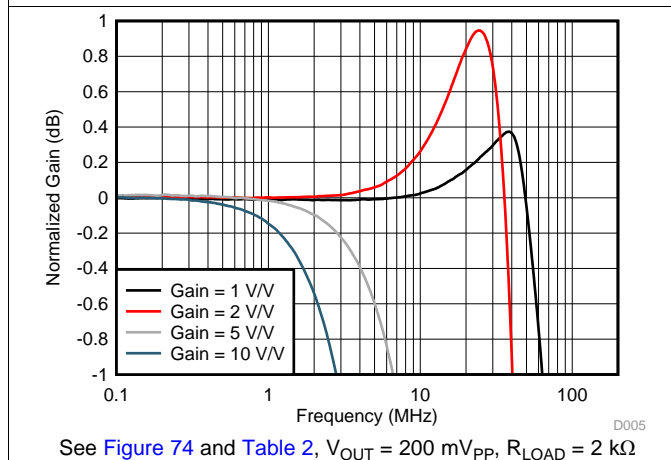

Figure 5. Noninverting Response Flatness vs Gain

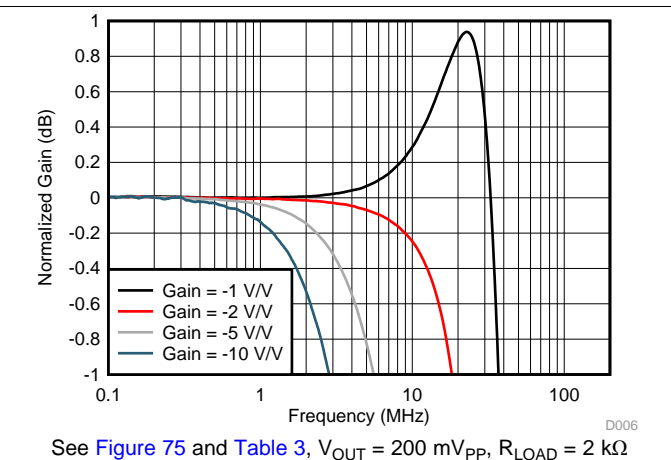
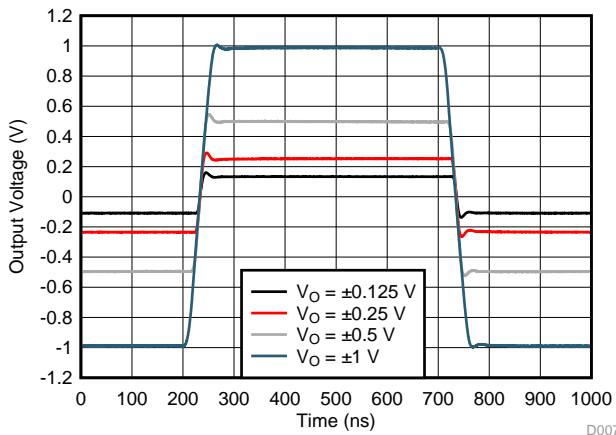

Figure 6. Inverting Response Flatness vs Gain

Typical Characteristics: $V_S = 5.0\text{ V}$ (continued)

at $V_{S+} = 5.0\text{ V}$, $V_{S-} = 0\text{ V}$, $V_{OUT} = 2\text{ V}_{PP}$, $R_F = 0\ \Omega$, $R_L = 2\text{ k}\Omega$, $G = 1\text{ V/V}$, input and output referenced to mid-supply, and $T_A \approx 25^\circ\text{C}$ (unless otherwise noted)



See Figure 74, gain = 2 V/V, input edge rate set to stay below slew limiting

Figure 7. Noninverting Step Response vs Time and V_{OPP}

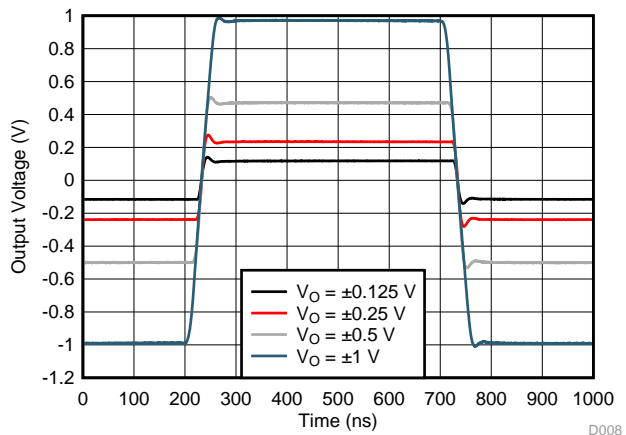

See Figure 75, gain = -1 V/V, input edge rate set to stay below slew limiting

Figure 8. Inverting Step Response vs Time and V_{OPP}

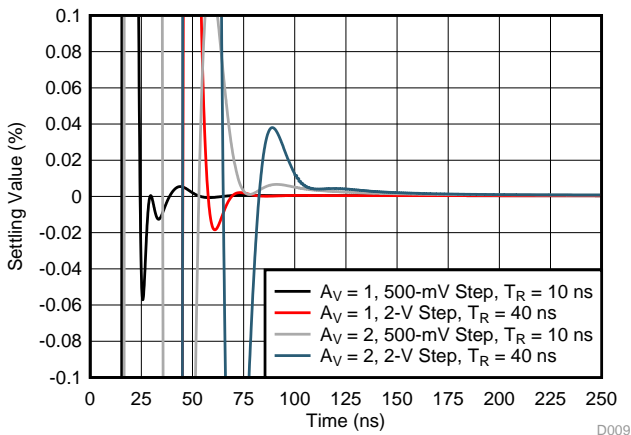

See Figure 74 and Table 2

Figure 9. Simulated Noninverting Settling Time

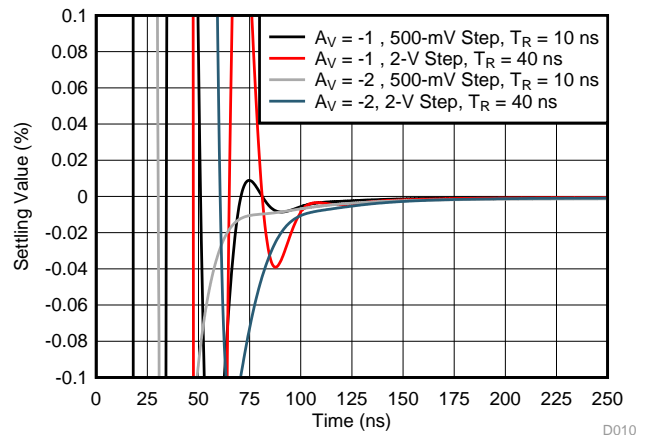

See Figure 75 and Table 3

Figure 10. Simulated Inverting Settling Time

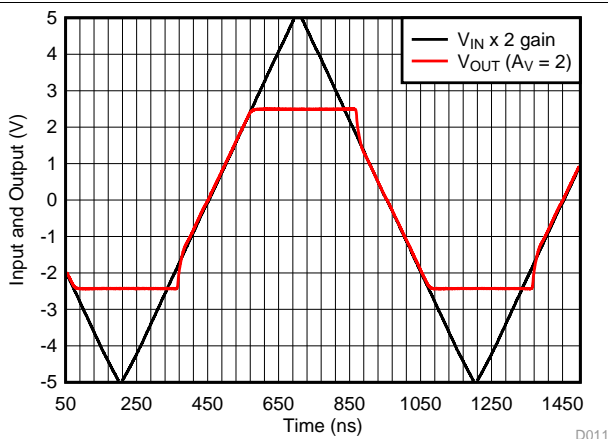

See Figure 74 and Table 2, gain = 2 V/V

Figure 11. Noninverting Overdrive Recovery

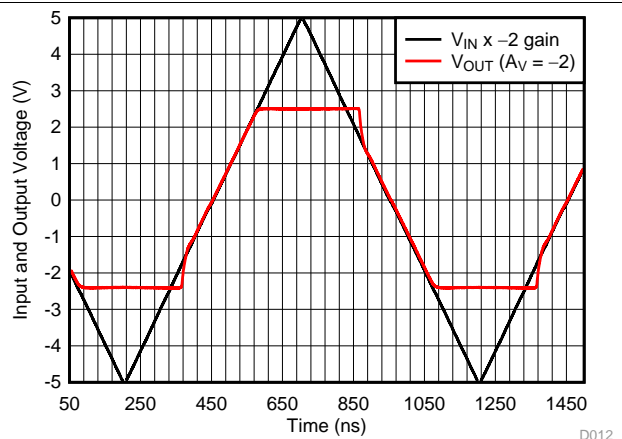

See Figure 75 and Table 3, gain -2 V/V

Figure 12. Inverting Overdrive Recovery

Typical Characteristics: $V_S = 5.0\text{ V}$ (continued)

at $V_{S+} = 5.0\text{ V}$, $V_{S-} = 0\text{ V}$, $V_{OUT} = 2\text{ V}_{PP}$, $R_F = 0\ \Omega$, $R_L = 2\text{ k}\Omega$, $G = 1\text{ V/V}$, input and output referenced to mid-supply, and $T_A \approx 25^\circ\text{C}$ (unless otherwise noted)

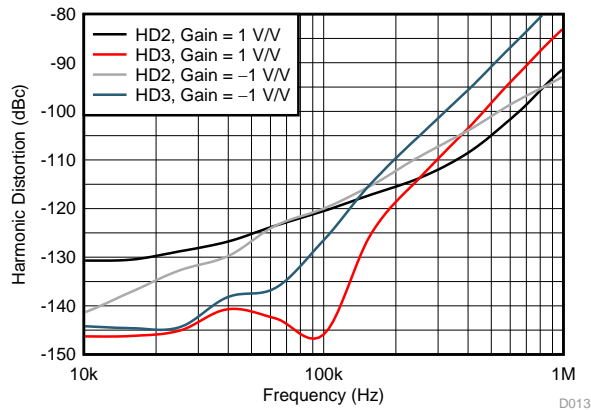

See Figure 74, Figure 75, Table 2, and Table 3, $V_{OUT} = 2\text{ V}_{PP}$

Figure 13. Harmonic Distortion vs Frequency

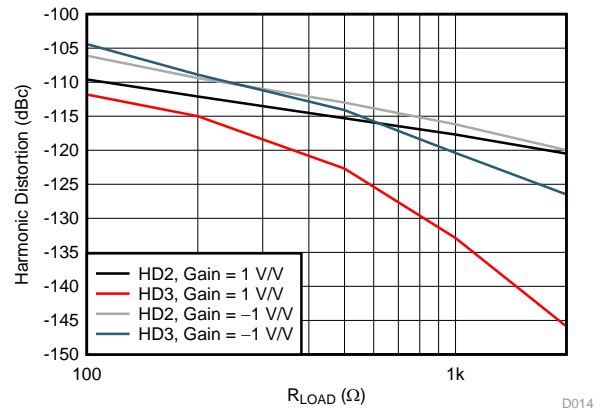

See Figure 74, Figure 75, Table 2, and Table 3, $V_{OUT} = 2\text{ V}_{PP}$, $f = 100\text{ kHz}$

Figure 14. Harmonic Distortion vs R_{LOAD}

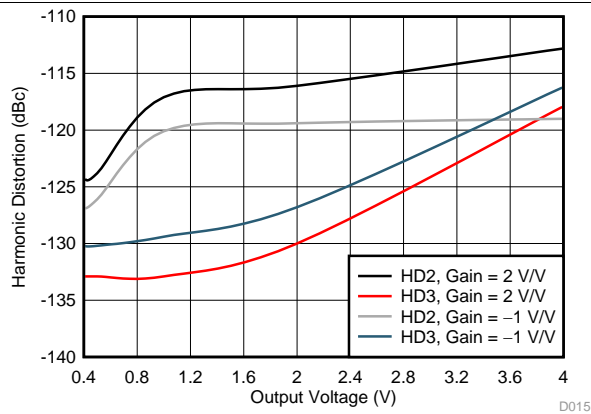

See Figure 74, Figure 75, Table 2, and Table 3, $V_{OUT} = 2\text{ V}_{PP}$, $f = 100\text{ kHz}$

Figure 15. Harmonic Distortion vs Output Voltage

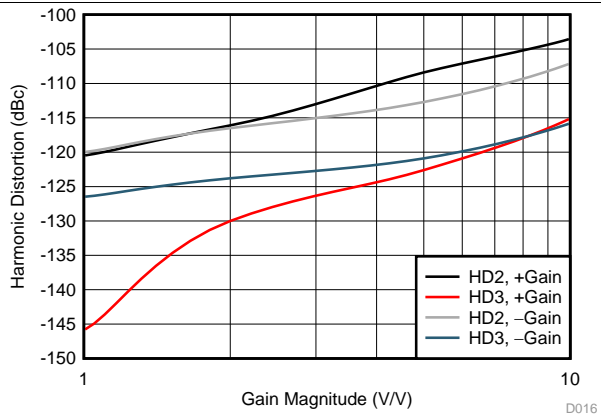

See Figure 74, Figure 75, Table 2, and Table 3, $V_{OUT} = 2\text{ V}_{PP}$, $f = 100\text{ kHz}$

Figure 16. Harmonic Distortion vs Gain Magnitude

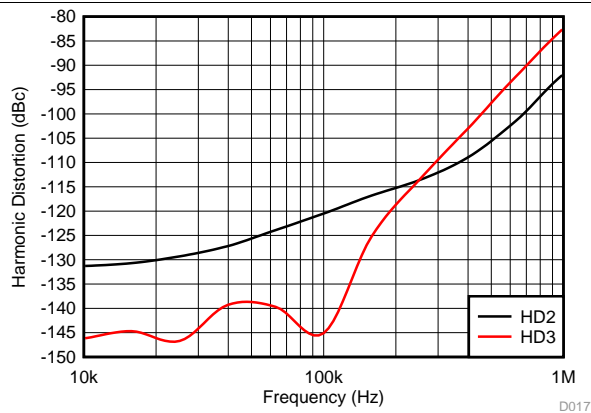

See Figure 87, $V_{OUT} = 2\text{ V}_{PP}$, $f = 100\text{ kHz}$

Figure 17. Harmonic Distortion as Active Mux

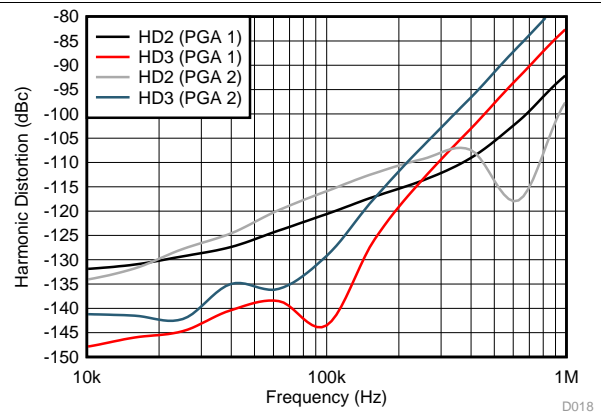

See Figure 87, gain of 1 V/V or 2 V/V, $V_{OUT} = 2\text{ V}_{PP}$, $f = 100\text{ kHz}$

Figure 18. Harmonic Distortion as 1-Bit PGA

6.9 Typical Characteristics: $V_S = 3.0\text{ V}$

at $V_{S+} = 3.0\text{ V}$, $V_{S-} = 0\text{ V}$, $V_{OUT} = 1\text{ V}_{PP}$, $R_F = 0\ \Omega$, $R_L = 2\text{ k}\Omega$, $G = 1\text{ V/V}$, input and output referenced to mid-supply, and $T_A \approx 25^\circ\text{C}$ (unless otherwise noted)

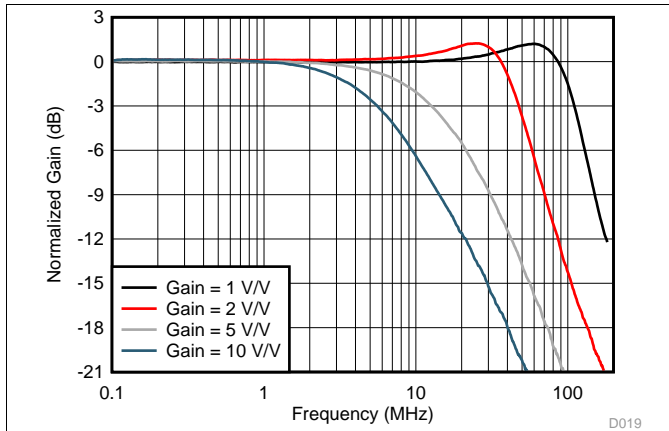

See Figure 74 and Table 2, $V_{OUT} = 20\text{ mV}_{PP}$, $R_{LOAD} = 2\text{ k}\Omega$

Figure 19. Noninverting Small-Signal Response vs Gain

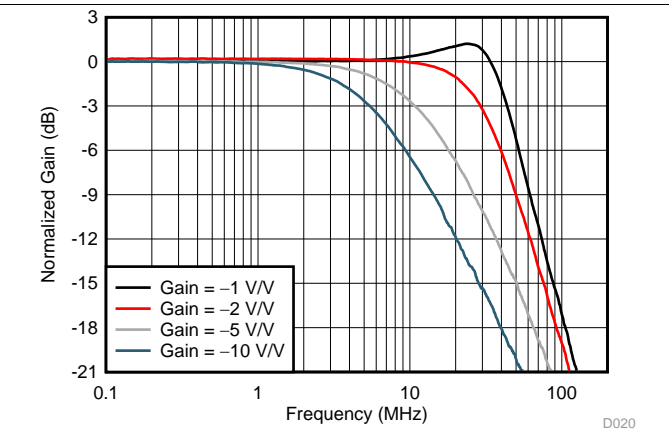

See Figure 75 and Table 3, $V_{OUT} = 20\text{ mV}_{PP}$, $R_{LOAD} = 2\text{ k}\Omega$

Figure 20. Inverting Small-Signal Response vs Gain

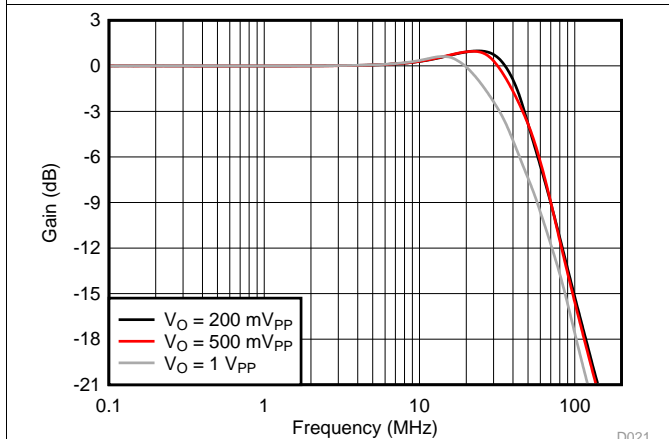

See Figure 74, gain = 2 V/V

Figure 21. Noninverting Large-Signal Bandwidth vs V_{OPP}

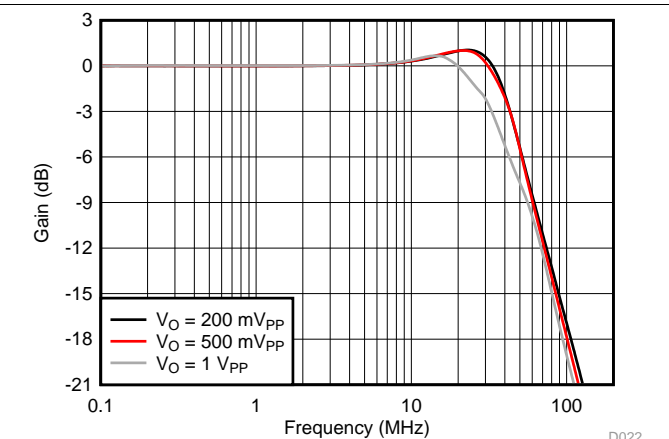

See Figure 75, gain = -1 V/V

Figure 22. Inverting Large-Signal Bandwidth vs V_{OPP}

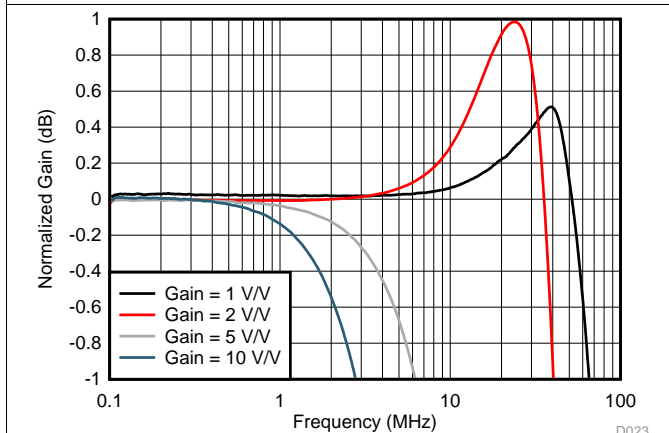

See Figure 74 and Table 2, $V_{OUT} = 200\text{ mV}_{PP}$, $R_{LOAD} = 2\text{ k}\Omega$

Figure 23. Noninverting Response Flatness vs Gain

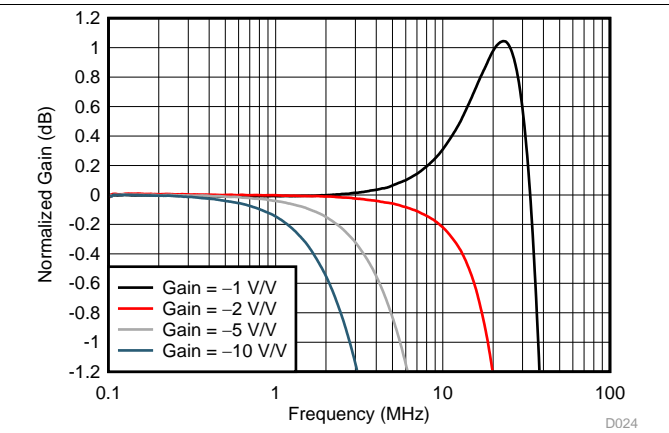

See Figure 75 and Table 3, $V_{OUT} = 200\text{ mV}_{PP}$, $R_{LOAD} = 2\text{ k}\Omega$

Figure 24. Inverting Response Flatness vs Gain

Typical Characteristics: $V_S = 3.0\text{ V}$ (continued)

at $V_{S+} = 3.0\text{ V}$, $V_{S-} = 0\text{ V}$, $V_{OUT} = 1\text{ V}_{PP}$, $R_F = 0\ \Omega$, $R_L = 2\text{ k}\Omega$, $G = 1\text{ V/V}$, input and output referenced to mid-supply, and $T_A \approx 25^\circ\text{C}$ (unless otherwise noted)

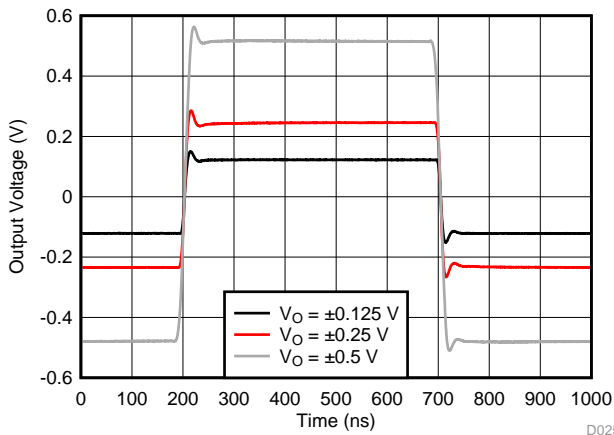

See Figure 74 and Table 2, gain = 2 V/V, input edge rate set to stay below slew limiting

Figure 25. Noninverting Step Response vs V_{OPP}

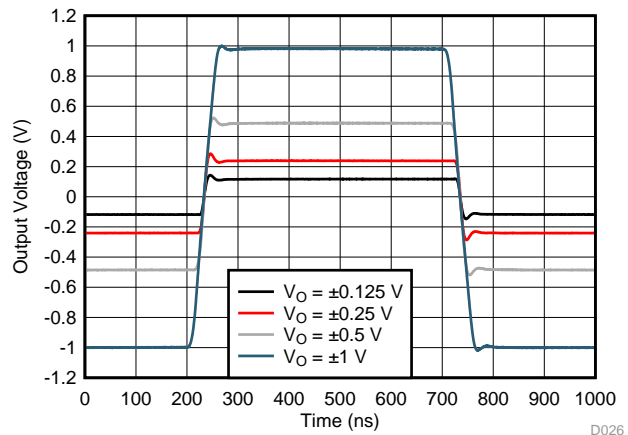

See Figure 75 and Table 3, gain = -1 V/V, input edge rate set to stay below slew limiting

Figure 26. Inverting Step Response vs V_{OPP}

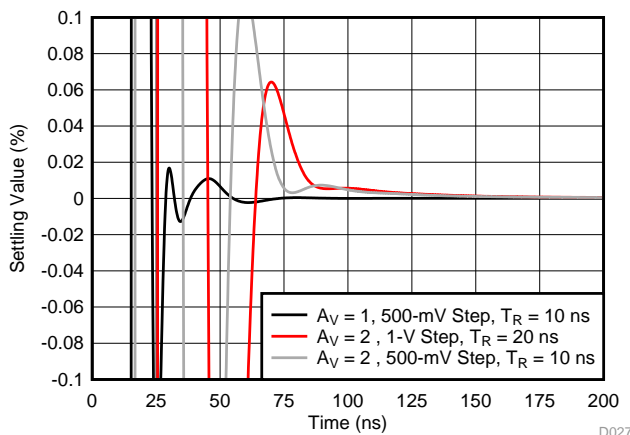

See Figure 74 and Table 2

Figure 27. Simulated Noninverting Settling Time

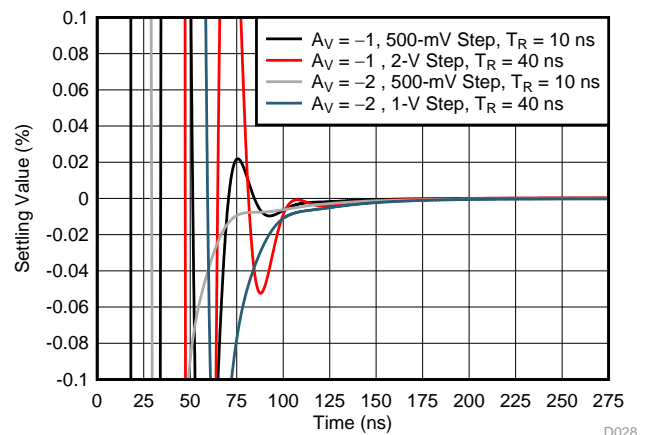

See Figure 75 and Table 3

Figure 28. Simulated Inverting Settling Time

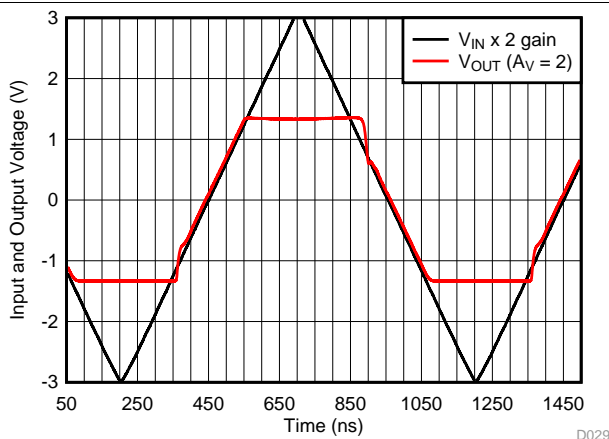

See Figure 74 and Table 2, gain = 2 V/V

Figure 29. Noninverting Overdrive Recovery

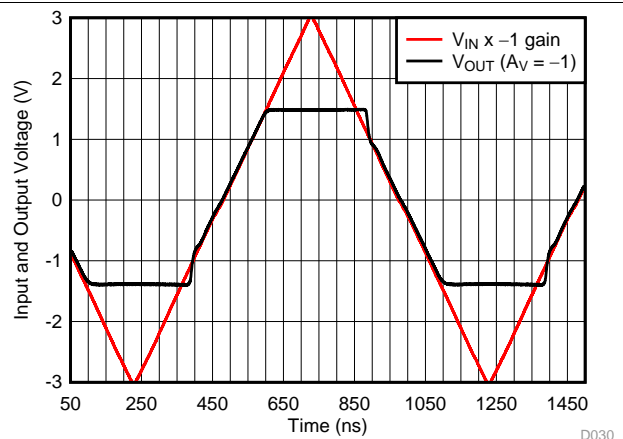

See Figure 75 and Table 3, gain = -1 V/V

Figure 30. Inverting Overdrive Recovery

Typical Characteristics: $V_S = 3.0\text{ V}$ (continued)

at $V_{S+} = 3.0\text{ V}$, $V_{S-} = 0\text{ V}$, $V_{OUT} = 1\text{ V}_{PP}$, $R_F = 0\ \Omega$, $R_L = 2\text{ k}\Omega$, $G = 1\text{ V/V}$, input and output referenced to mid-supply, and $T_A \approx 25^\circ\text{C}$ (unless otherwise noted)

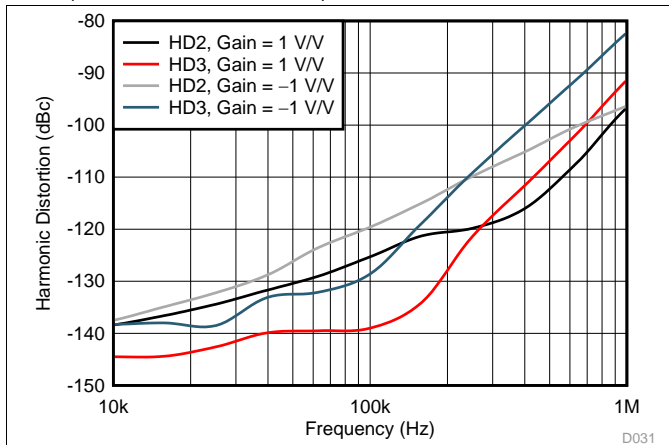

See Figure 74, Figure 75, Table 2, and Table 3, $V_{OUT} = 1\text{ V}_{PP}$, $R_{LOAD} = 2\text{ k}\Omega$

Figure 31. Harmonic Distortion vs Frequency

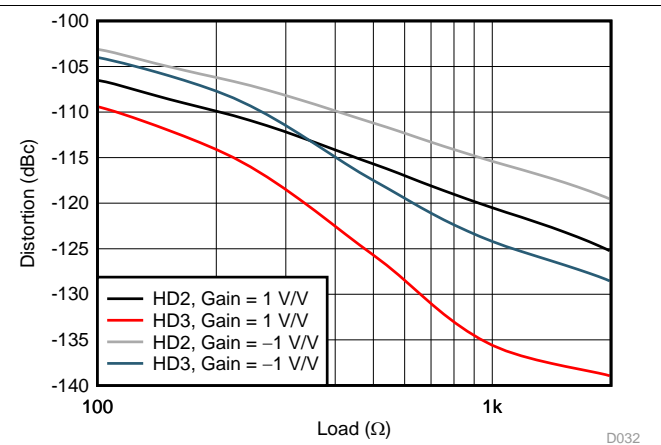

See Figure 74, Figure 75, Table 2, and Table 3, $V_{OUT} = 1\text{ V}_{PP}$, $f = 100\text{ kHz}$, $R_{LOAD} = 2\text{ k}\Omega$

Figure 32. Harmonic Distortion vs R_{LOAD}

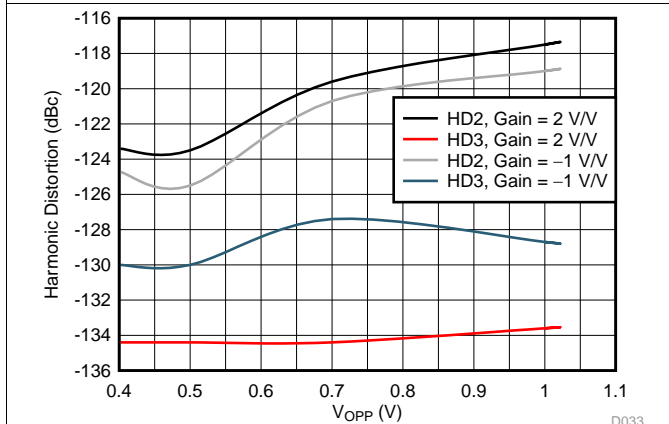

See Figure 74, Figure 75, Table 2, and Table 3, $R_{LOAD} = 2\text{ k}\Omega$, $f = 100\text{ kHz}$

Figure 33. Harmonic Distortion vs Output Swing

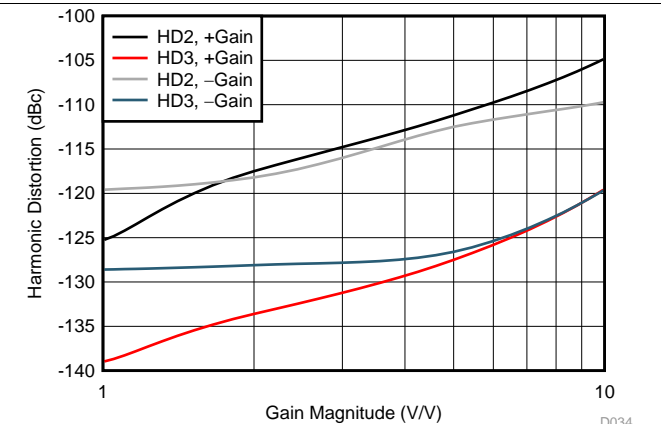

See Figure 74, Figure 75, Table 2, and Table 3, $R_{LOAD} = 2\text{ k}\Omega$, $f = 100\text{ kHz}$, $V_{OUT} = 1\text{ V}_{PP}$

Figure 34. Harmonic Distortion vs Gain Magnitude

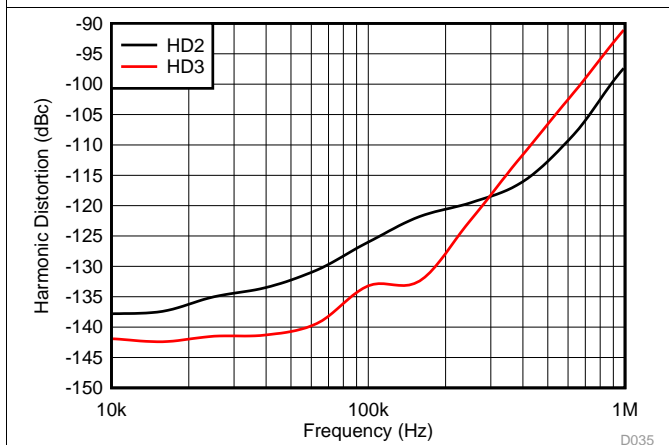

See Figure 87, gain = 1 V/V, $V_{OUT} = 1\text{ V}_{PP}$, $R_{LOAD} = 2\text{ k}\Omega$

Figure 35. Harmonic Distortion as Active Mux

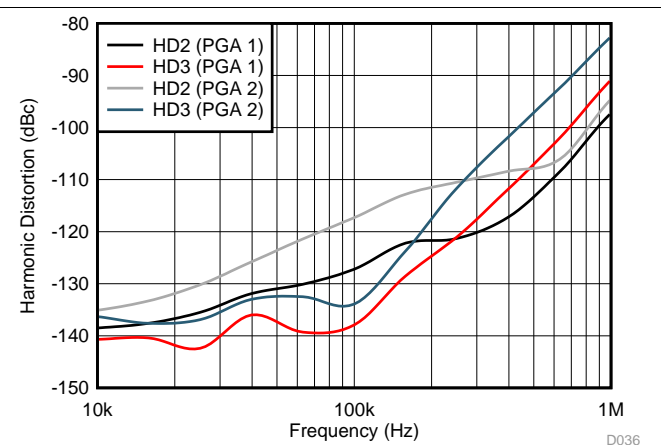

See Figure 88, gain of 1 V/V and 2 V/V, $V_{OUT} = 1\text{ V}_{PP}$, $R_{LOAD} = 2\text{ k}\Omega$

Figure 36. Harmonic Distortion as 1-Bit PGA

6.10 Typical Characteristics: ±2.5-V to ±1.5-V Split Supply

with $P_D = V_{CC}$ and $T_A \approx 25^\circ\text{C}$ (unless otherwise noted)

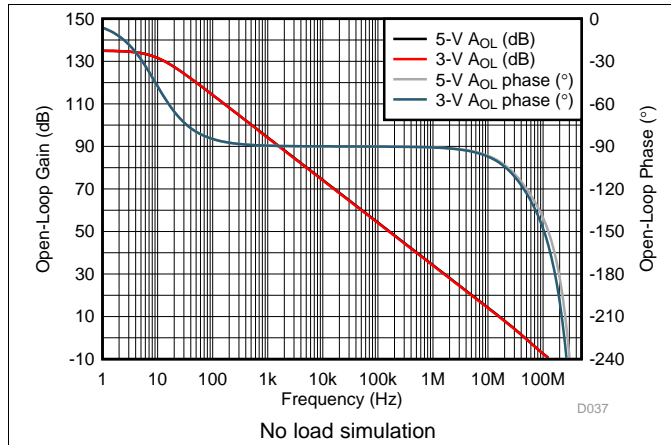

Figure 37. Open-Loop Gain and Phase vs Frequency

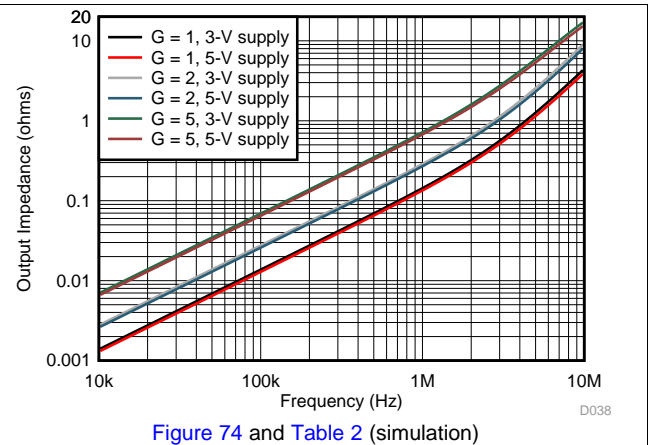

Figure 74 and Table 2 (simulation)

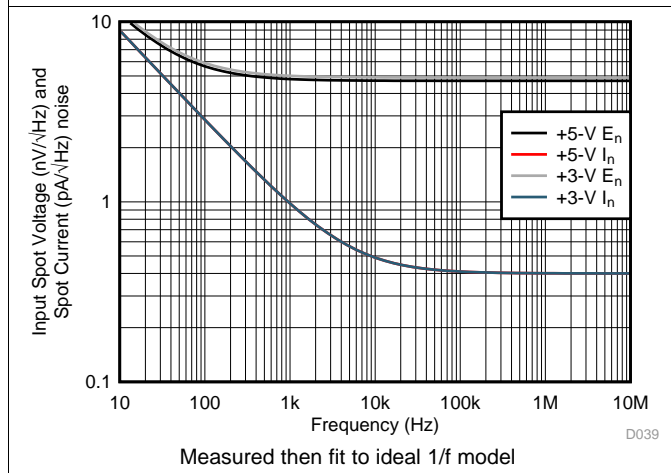

Figure 39. Input Spot Noise Density vs Frequency

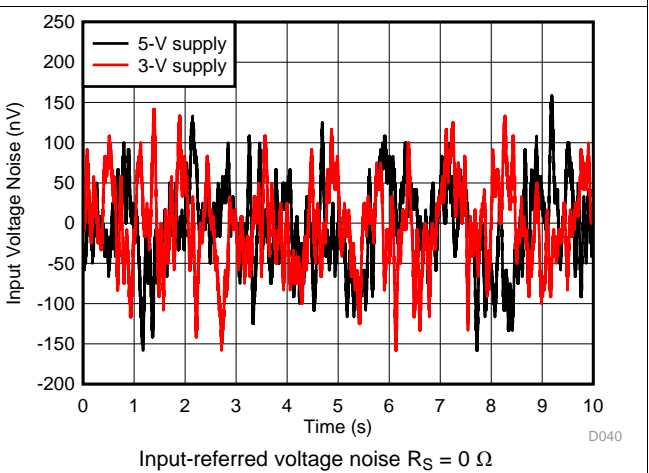

Figure 40. Low-Frequency Voltage Noise vs Time

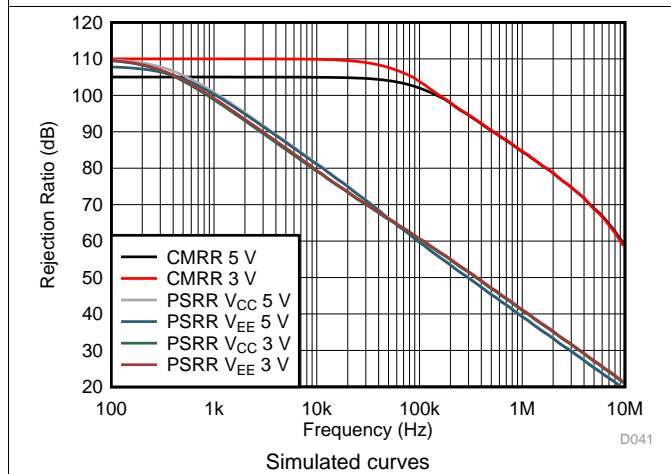

Figure 41. CMRR and PSRR vs Frequency

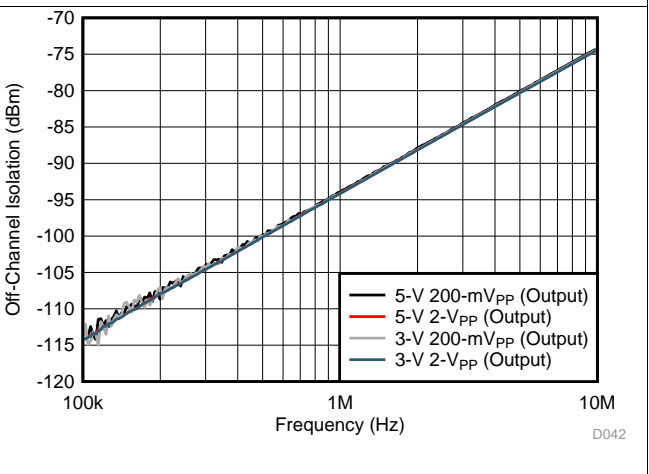
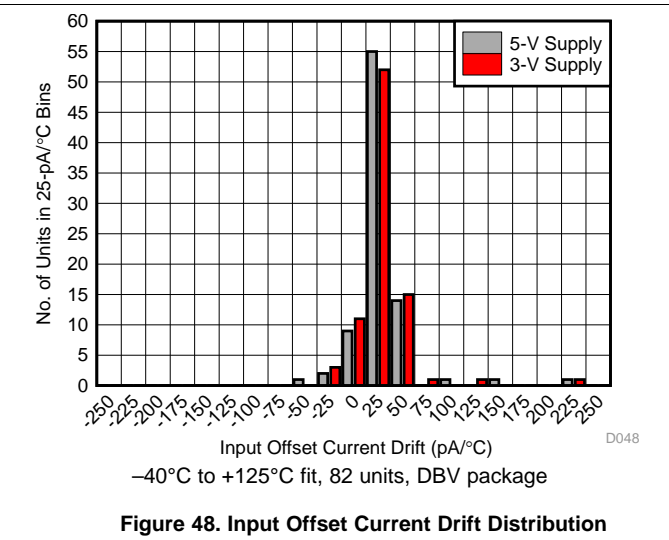
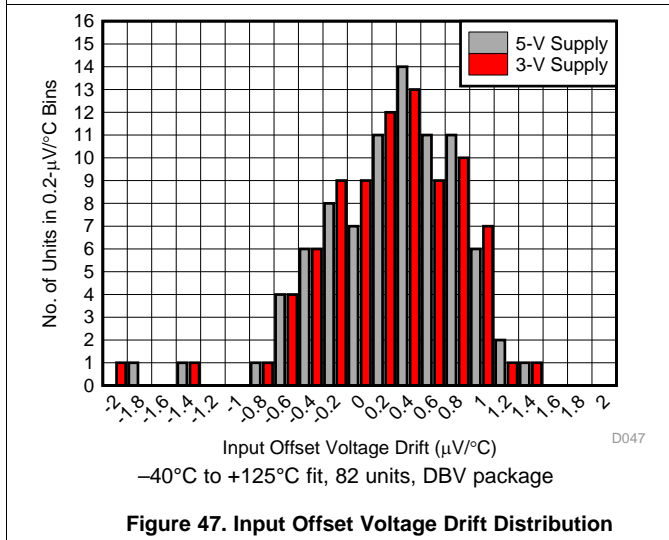
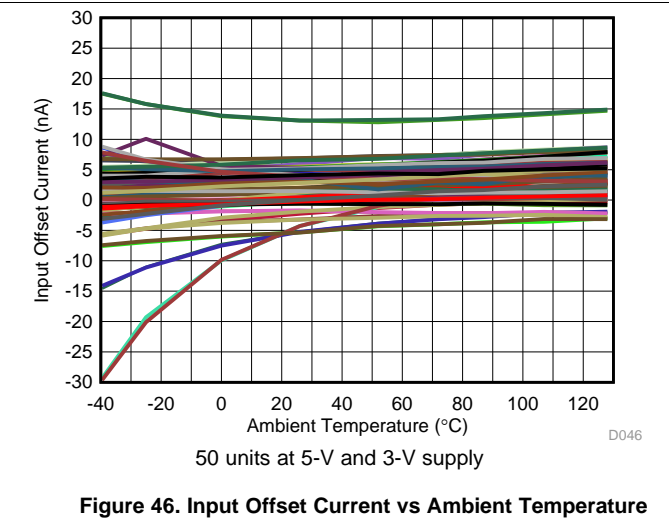
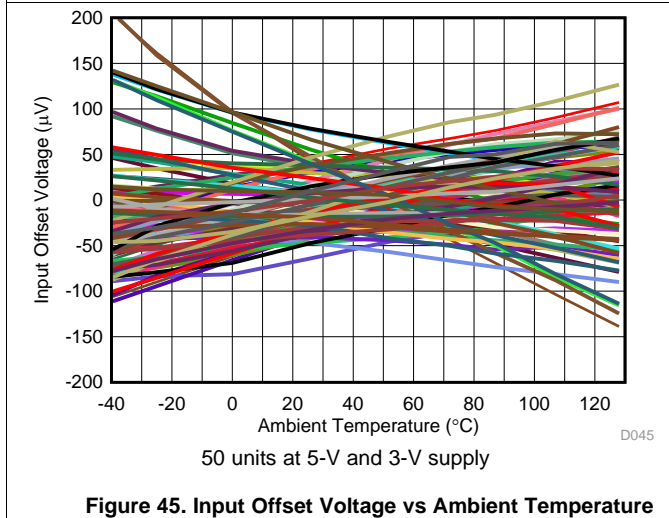
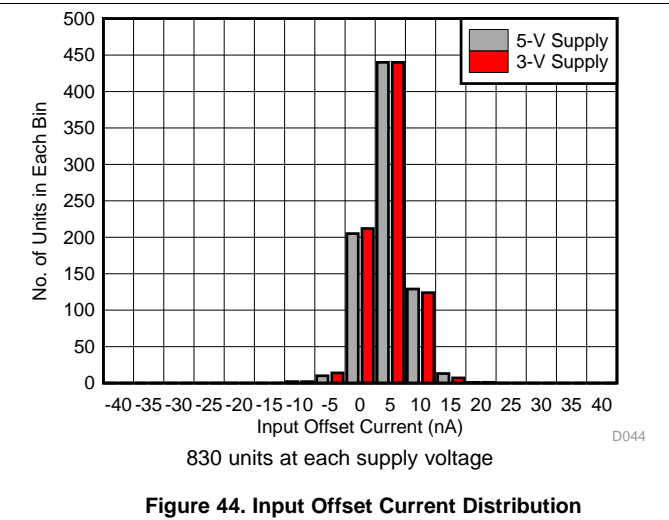
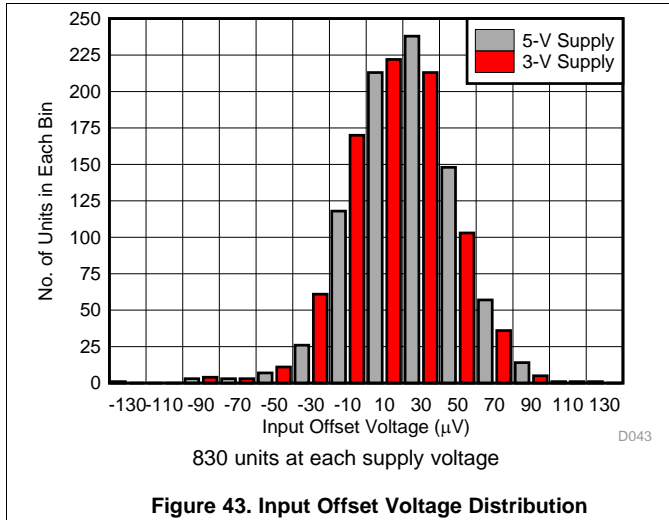

Figure 42. Disabled Isolation Noninverting Input to Output vs Frequency

Typical Characteristics: ±2.5-V to ±1.5-V Split Supply (continued)

with $P_D = V_{CC}$ and $T_A \approx 25^\circ\text{C}$ (unless otherwise noted)



Typical Characteristics: ±2.5-V to ±1.5-V Split Supply (continued)

with $P_D = V_{CC}$ and $T_A \approx 25^\circ\text{C}$ (unless otherwise noted)

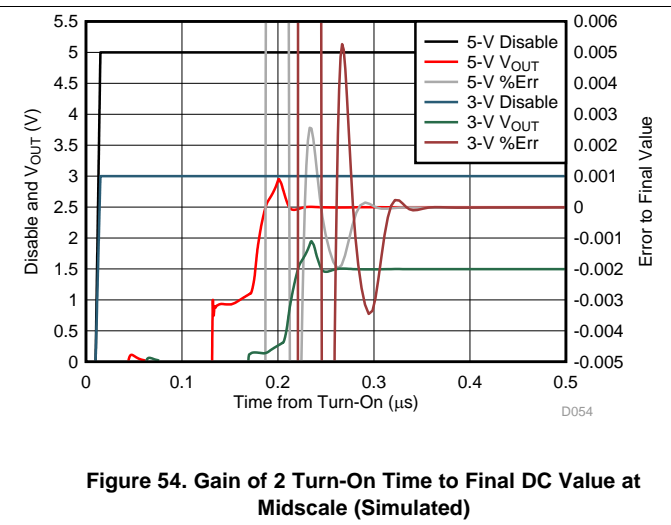
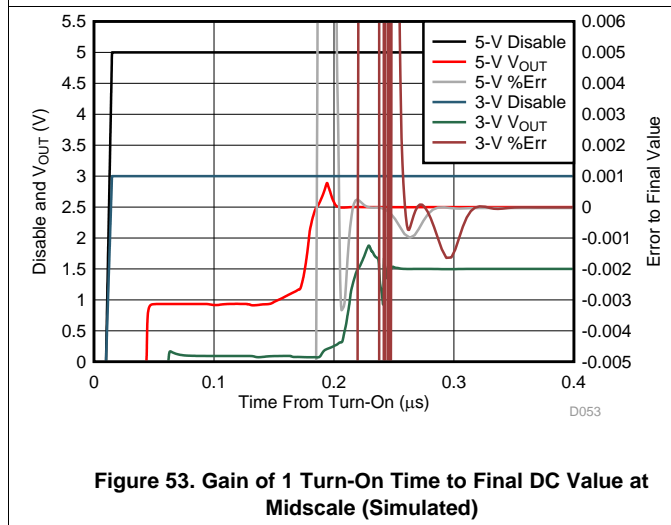
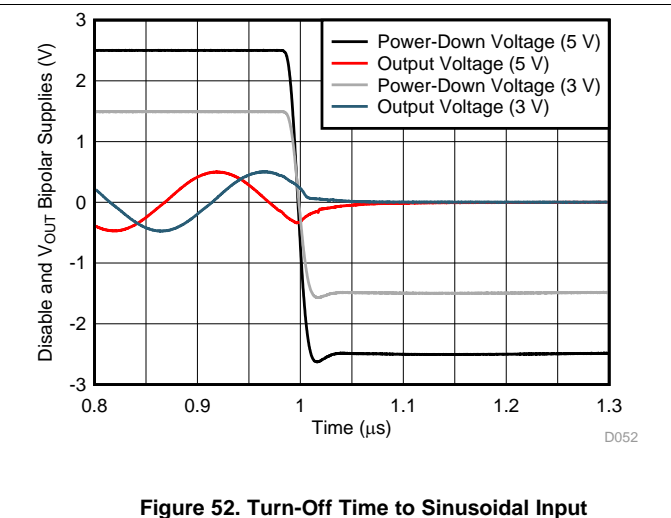
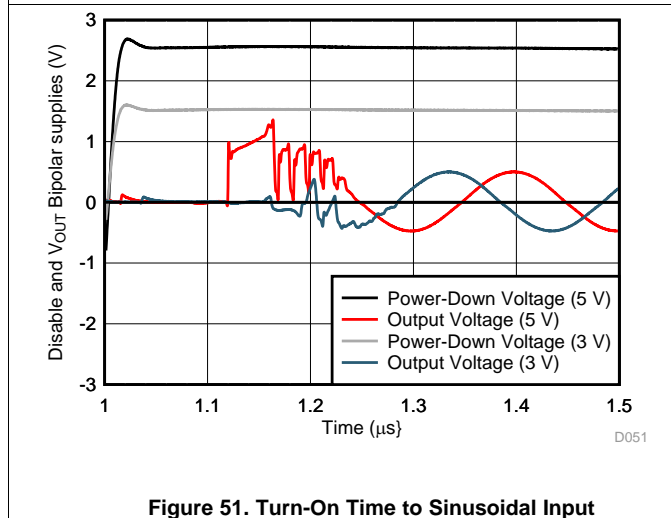
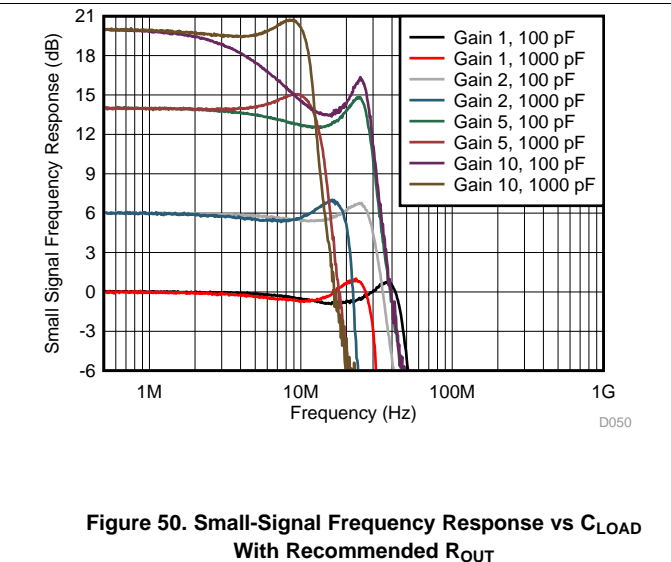
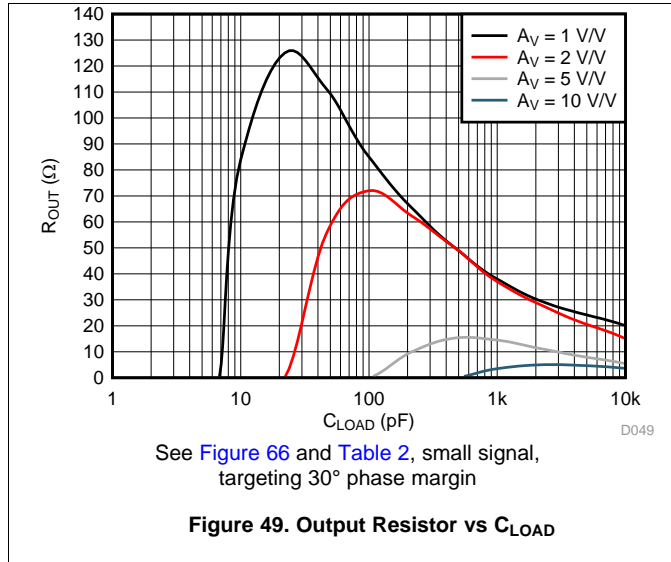

Typical Characteristics: ±2.5-V to ±1.5-V Split Supply (continued)

with $P_D = V_{CC}$ and $T_A \approx 25^\circ\text{C}$ (unless otherwise noted)

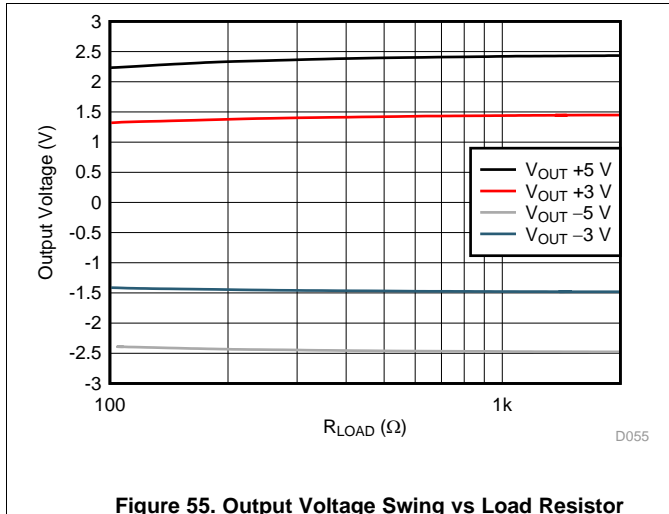

Figure 55. Output Voltage Swing vs Load Resistor

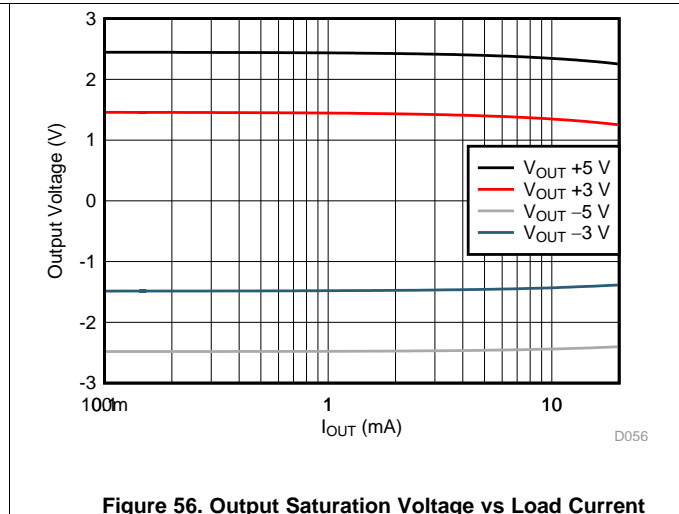

Figure 56. Output Saturation Voltage vs Load Current

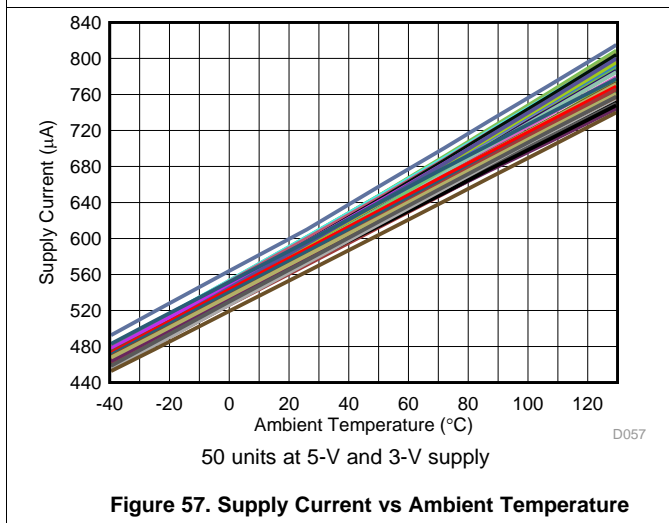

Figure 57. Supply Current vs Ambient Temperature

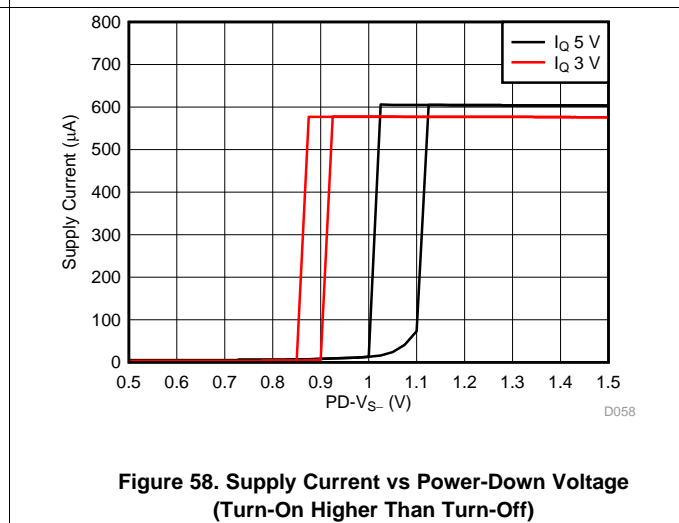

Figure 58. Supply Current vs Power-Down Voltage (Turn-On Higher Than Turn-Off)

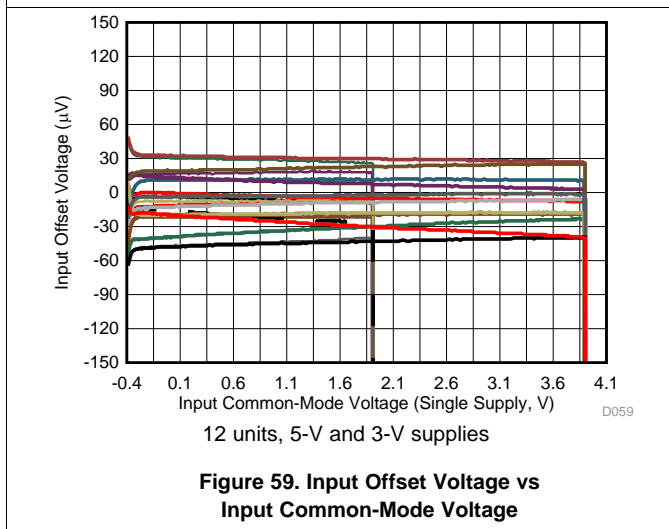

Figure 59. Input Offset Voltage vs Input Common-Mode Voltage

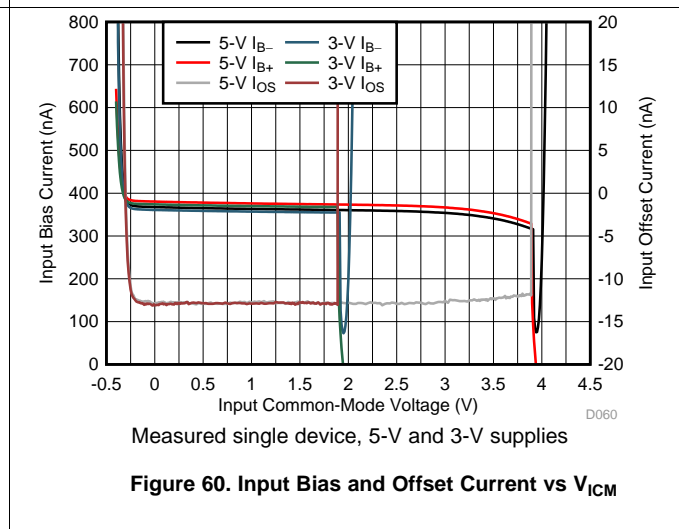
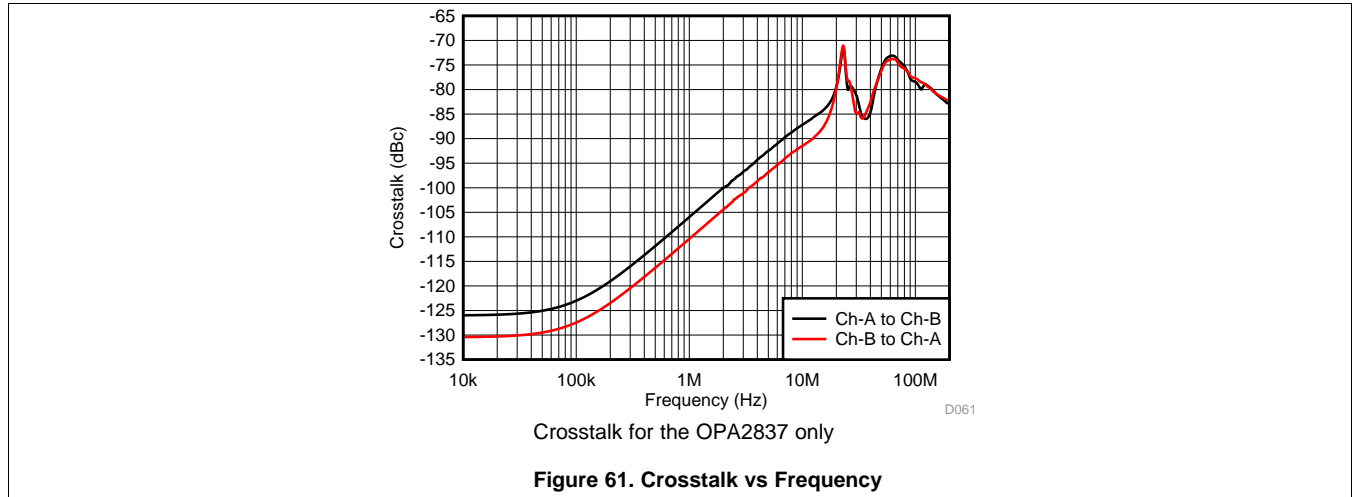

Figure 60. Input Bias and Offset Current vs V_{ICM}

Typical Characteristics: ±2.5-V to ±1.5-V Split Supply (continued)

with $P_D = V_{CC}$ and $T_A \approx 25^\circ\text{C}$ (unless otherwise noted)



7 Detailed Description

7.1 Overview

The OPA837 and OPA2837 are single- and dual-channel, power efficient, unity-gain stable, voltage-feedback amplifiers (VFAs). Combining a negative rail input stage and a rail-to-rail output (RRO) stage, the OPAx837 provides a flexible solution where exceptional precision and wide bandwidth at low power are required. This 50-MHz gain bandwidth product (GBP) amplifier requires less than 0.65 mA of supply current per channel over a 2.7-V to 5.4-V total supply operating range. A shutdown feature on the OPA837 6-pin package version provides power savings where the system requires less than 10 μ A when shut down. Offering a unity-gain bandwidth greater than 100 MHz, the OPAx837 provides less than -118 -dBc THD at 100 kHz and a 2 -V_{PP} output.

7.2 Functional Block Diagrams

The OPAx837 is a standard voltage-feedback op amp with two high-impedance inputs and a low-impedance output. [Figure 62](#) and [Figure 63](#) show the supported standard applications circuits. These application circuits are shown with a DC V_{REF} on the inputs that set the DC operating points for single-supply designs. The V_{REF} is often ground, especially for split-supply applications.

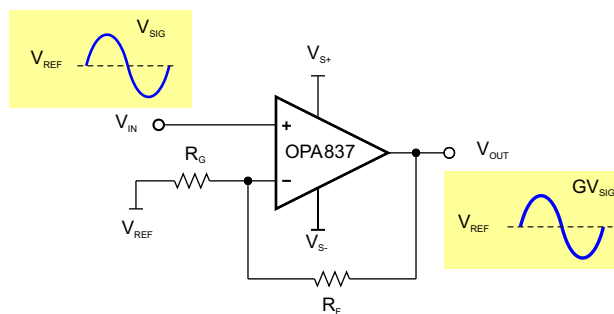

Figure 62. Noninverting Amplifier

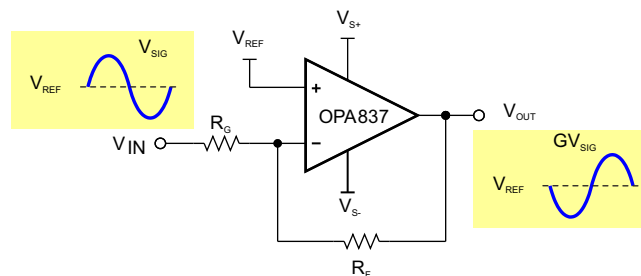

Figure 63. Inverting Amplifier

7.3 Feature Description

7.3.1 OPA837 Comparison

Table 1 lists several members of the device family that includes the OPA837.

Table 1. Device Family Comparison⁽¹⁾

PART NUMBER	A _v = +1 BANDWIDTH (MHz)	5-V I _Q (mA, Max 25°C)	INPUT NOISE VOLTAGE (nV/√Hz)	2-V _{PP} THD (dBc, 100 kHz)	RAIL-TO-RAIL INPUT/OUTPUT	DUALS
OPA837	105	0.63	4.7	–118	V _{S–} , output	OPA2837
OPA838	—	0.99	1.9	–110	V _{S–} , output	—
LMV118	45	0.9	40	—	V _{S–} , output	—
LMH6647	55	1.6	17	–75	Input, output	LMH6646
OPA835	56	0.35	9.4	–104	V _{S–} , output	OPA2835
OPA625	120	2.2	2.5	–120	V _{S–} , output	OPA2625
OPA836	205	1.0	4.6	–118	V _{S–} , output	OPA2836

(1) For a complete selection of TI high speed amplifiers, visit www.ti.com.

7.3.2 Input Common-Mode Voltage Range

When the primary design goal is a linear amplifier with high CMRR, the design must remain within the input common-mode voltage range (V_{ICR}) of an op amp. These ranges are referenced off of each supply as an input headroom requirement. Ensured operation at 25°C is maintained to the negative supply voltage and to within 1.3 V of the positive supply voltage. The common-mode input range specifications in the *Electrical Characteristics* table use CMRR to set the limit. The limits are selected to ensure CMRR does not degrade more than 3 dB below the minimum CMRR value if the input voltage is within the specified range.

Assuming the op amp is in linear operation, the voltage difference between the input pins is small (ideally 0 V); and the input common-mode voltage is analyzed at either input pin with the other input pin assumed to be at the same potential. The voltage at V_{IN+} is simple to evaluate. In the noninverting configuration of Figure 62, the input signal, V_{IN}, must not violate the V_{ICR}. In the inverting configuration of Figure 63, the reference voltage, V_{REF}, must be within the V_{ICR}.

The input voltage limits have fixed headroom to the power rails and track the power-supply voltages. For one 5-V supply, the typical linear input voltage ranges from –0.2 V to 3.8 V and –0.2 V to 1.5 V for a 2.7-V supply. The delta headroom from each power-supply rail is the same in either case: –0.2 V and 1.2 V, respectively.

7.3.3 Output Voltage Range

The OPAx837 is a rail-to-rail output op amp. Rail-to-rail output typically means that the output voltage swings to within 100 mV of the supply rails. There are two different ways to specify this feature: one is with the output still in linear operation and another is with the output saturated. Saturated output voltages are closer to the power-supply rails than the linear outputs, but the signal is not a linear representation of the input. Saturation and linear operation limits are affected by the output current, where higher currents lead to more voltage loss in the output transistors; see Figure 55.

The *Electrical Characteristics* tables list saturated output voltage specifications with a 2-kΩ load. Figure 55 illustrates the saturated voltage-swing limits versus output load resistance, and Figure 56 illustrates the output saturation voltage versus load current. Given a light load, the output voltage limits have nearly constant headroom to the power rails and track the power-supply voltages. For example, with a 2-kΩ load and a single 5-V supply, the linear output voltage ranges from 0.10 V to 4.9 V and ranges from 0.1 V to 2.6 V for a 2.7-V supply. The delta from each power-supply rail is the same in either case: 0.1 V.

With devices like the OPA837 and OPA2837 where the input range is lower than the output range, typically the input limits the available signal swing only in a noninverting gain of 1 V/V. Signal swing in noninverting configurations in gains greater than +1 V/V and inverting configurations in any gain are typically limited by the output voltage limits of the op amp.

7.3.4 Power-Down Operation

The OPA837 includes a power-down mode in the 6-pin SOT23-6 package. Under logic control, the amplifier can switch from normal operation to a standby current of less than 10 μA . When the $\overline{\text{PD}}$ pin is connected high, the amplifier is active. Connecting the $\overline{\text{PD}}$ pin low disables the amplifier and places the output in a high-impedance state. When the amplifier is configured as a unity-gain buffer, the output stage is in a high DC-impedance state. A new feature in the OPA837 is a switch from the external inverting input pin to the internal active transistors. This switch operates with the disable pin function to open up the connection to the internal devices when powered down. Operating in unity gain provides a high-impedance voltage into both the output and inverting input pins. This feature allows direct active multiplexer operation to be implemented; see [Figure 87](#). The [TIDA-01565 Wired OR MUX and PGA Reference Design](#) demonstrates the use of the OPAX837 in wired-OR multiplexer and programmable gain amplifier applications. When disabled, the internal input devices on the inverting input approximately follow the noninverting input on the other side of the open switch through the back-to-back protection diodes across the inputs. When powered up, these diodes (two in each direction) act to limit overdrive currents into the active transistors.

The $\overline{\text{PD}}$ pin must be actively driven high or low and must not be left floating. If the power-down mode is not used, $\overline{\text{PD}}$ must be tied to the positive supply rail.

$\overline{\text{PD}}$ logic states are referenced relatively low to the negative supply rail, $V_{\text{S-}}$. When the op amp is powered from a single-supply and ground, and the disable line is driven from logic devices with similar V_{DD} voltages to the op amp, the disable operation does not require any special consideration. The OPA837 is specified to be off with $\overline{\text{PD}}$ driven to within 0.55 V of the negative supply and specified to be on when driven more than 1.5 V above the negative supply. Slight hysteresis is provided around a nominal 1-V switch point; see [Figure 58](#). When the op amp is powered from a split supply with $V_{\text{S-}}$ below ground, a level shift logic swing below ground is required to operate the disable function.

7.3.5 Low-Power Applications and the Effects of Resistor Values on Bandwidth

The OPAX837 can use a direct short in the feedback for a gain of 1 V/V. [Table 2](#) gives a list of recommended values over gain for an increasing noninverting gain target. This table was produced by increasing the R values until they added 50% of the total output noise power. Higher values can be used to reduce power at the cost of higher noise. Lower values can be used to reduce the total output noise at the cost of more load power in the feedback network. Stability is also impaired going to very high values because of the pole introduced into the feedback path with the inverting input capacitance (1.5-pF common-mode). In low-power applications, reducing the current in the feedback path is preferable by increasing the resistor values. Using larger value resistors has two primary side effects (other than lower power) because of the interactions with the inverting input parasitic capacitance. Using large value resistors lowers the bandwidth and lowers the phase margin. When the phase margin is lowered, peaking in the frequency response and overshoot and ringing in the pulse response results.

[Figure 64](#) shows the gain = 2 V/V (6 dB) small-signal frequency response with R_{F} and R_{G} equal to 1 k Ω , 2 k Ω , 5 k Ω , 10 k Ω , and 20 k Ω . This test was done with $R_{\text{L}} = 2$ k Ω . Lower R_{L} values can reduce the peaking because of R_{L} loading effects, but higher values do not have a significant effect.

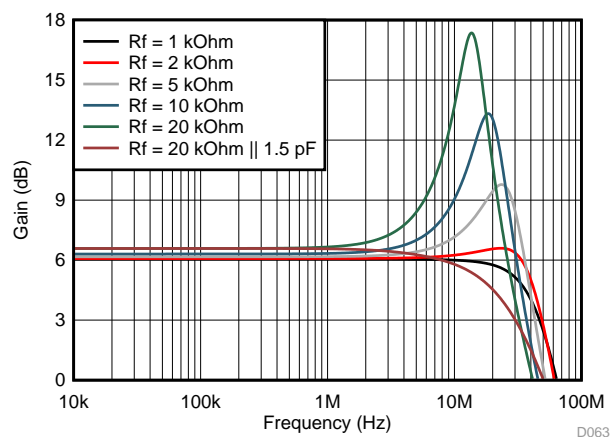

Figure 64. Frequency Response With Various $R_{\text{F}} = R_{\text{G}}$ Resistor Values

As expected, larger value resistors cause lower bandwidth and peaking in the response (peaking in frequency response is synonymous with overshoot and ringing in pulse response). Adding a 1.5-pF capacitor in parallel with R_F (equal to the input common-mode capacitance) helps compensate the phase margin loss and restores flat frequency response. Figure 65 shows the test circuit.

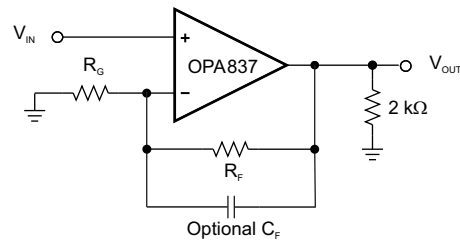

Figure 65. $G = 2$ Test Circuit for Various Gain-Setting Resistor Values

7.3.6 Driving Capacitive Loads

The OPAx837 can drive a parasitic load capacitance up through 4 pF on the output with no special considerations. When driving capacitive loads greater than 4 pF, TI recommends using a small resistor (R_O) in series with the output as close to the device as possible. Without R_O output capacitance interacts with the output impedance of the amplifier causing phase shift in the loop gain of the amplifier that reduces the phase margin. This reduction causes peaking in the frequency response and overshoot and ringing in the pulse response. Inserting R_O isolates the phase shift from the loop-gain path and restores the phase margin; however R_O can also limit bandwidth to the capacitive load.

Figure 66 shows the test and Figure 49 illustrates the recommended values of R_O versus capacitive loads, C_L using a 30° phase margin target for the op amp. See Figure 50 for the frequency responses with various values of C_L and R_{OUT} parametric on gain.

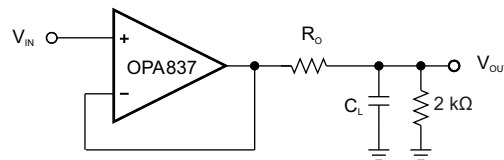

Figure 66. R_{OUT} versus C_L Test Circuit

7.4 Device Functional Modes

7.4.1 Split-Supply Operation ($\pm 1.35\text{ V}$ to $\pm 2.7\text{ V}$)

To facilitate testing with common lab equipment, the OPA837EVM (see the [OPA835DBV and OPA836DBV EVM User's Guide](#)) allows split-supply operation. This configuration eases lab testing because the mid-point between the power rails is ground, and most signal generators, network analyzers, oscilloscopes, spectrum analyzers, and other lab equipment have inputs and outputs that prefer a ground reference for DC-coupled testing.

Figure 67 shows a simple noninverting configuration analogous to Figure 62 with a $\pm 2.5\text{-V}$ supply and V_{REF} equal to ground. The input and output swing symmetrically around ground. For ease of use, split supplies are preferred in systems where signals swing around ground. In this example, an optional bias current cancellation resistor is used in series with the noninverting input. For DC-coupled applications, set this resistor to be equal to the parallel combination of R_F and R_G . This resistor increases the noise contribution at the input because of that resistor noise (see the [Output Noise Calculations](#) section).

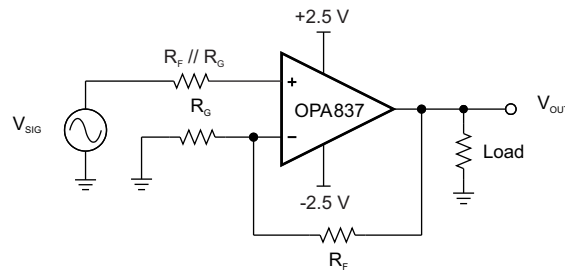

Figure 67. Split-Supply Operation

Figure 68 shows the step response for this gain of 2-V/V circuit with a $\pm 1\text{-V}$ input to a $\pm 2\text{-V}$ output. For a 4-V output step, the input edge rate is set to 40 ns to avoid slew limiting.

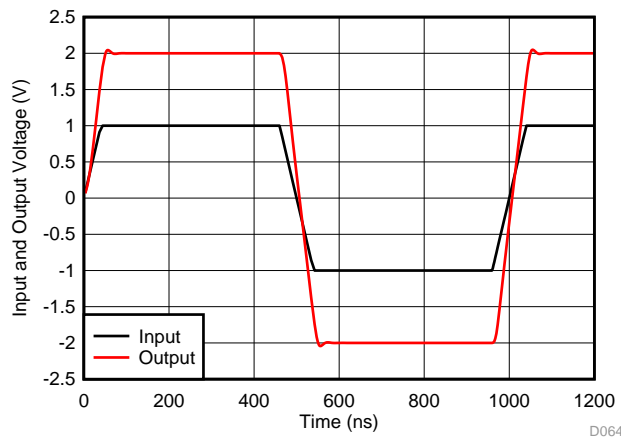

Figure 68. V_{IN} and V_{OUT} vs Time

Device Functional Modes (continued)

7.4.2 Single-Supply Operation (2.7 V to 5.4 V)

Most newer systems use a single power supply to improve efficiency and to simplify power-supply design. The OPAx837 can be used with single-supply power (ground for the negative supply) with no change in performance from split supply, as long as the input and output pins are biased within the linear operating region of the device. The outputs nominally swing rail-to-rail with approximately a 100-mV headroom required for linear operation. The inputs can typically swing 0.2 V below the negative rail (typically ground) and to within 1.2 V of the positive supply. For DC-coupled single-supply operation, the input swing is below the available output swing range for noninverting gains greater than 1.30 V/V. Typically, the 1.2-V input headroom required to the positive supply only limits output swing range for a unity-gain buffer.

To change the circuit from split supply to single-supply, level shift all voltages by half the difference between the power-supply rails. For example, Figure 69 depicts changing from a ± 2.5 -V split supply to a 5-V single-supply. The load is shown as mid-supply referenced but can be grounded as well.

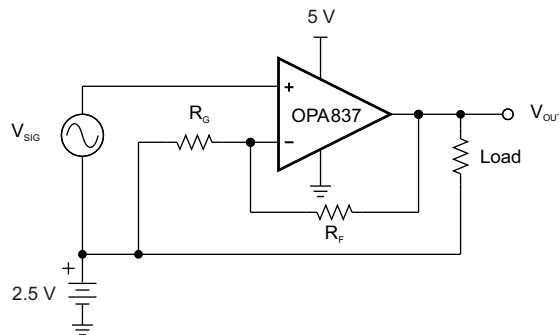

Figure 69. Single-Supply Concept

A practical circuit has an amplifier or other circuit providing the bias voltage for the input, and the output of this amplifier stage provides the bias for the next stage.

Figure 70 shows a typical noninverting amplifier circuit. With 5-V single-supply, a mid-supply reference generator is needed to bias the negative side through R_G . To cancel the voltage offset that is otherwise caused by the input bias currents, R_1 is selected to be equal to R_F in parallel with R_G . For example, if a gain of 2 V/V is required and $R_F = 2$ k Ω , select $R_G = 2$ k Ω to set the gain, and $R_1 = 1$ k Ω for bias current cancellation which reduces the output DC error to $I_{OS} \times R_F$. The value for C is dependent on the reference, and TI recommends a value of at least 0.1 μ F to limit noise. The frequency response flatness is impacted by the AC impedance, including the reference and capacitor added to the R_G element.

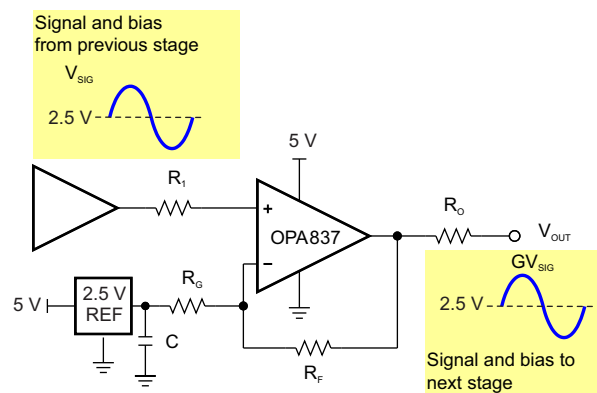

Figure 70. Noninverting Single-Supply Operation With Reference

Device Functional Modes (continued)

Figure 71 shows a similar noninverting single-supply scenario with the reference generator replaced by the Thevenin equivalent using resistors and the positive supply. R_G' and R_G'' form a resistor divider from the 5-V supply and are used to bias the negative side with the parallel sum equal to the equivalent R_G to set the gain. To cancel the voltage offset that is otherwise caused by the input bias currents, R_1 is selected to be equal to R_F in parallel with R_G ($R_1 = R_F \parallel R_G' \parallel R_G''$). For example, if a gain of 2 V/V is required and $R_F = 2\text{ k}\Omega$, selecting $R_G' = R_G'' = 4\text{ k}\Omega$ gives an equivalent parallel sum of $2\text{ k}\Omega$, sets the gain to 2, and references the input to mid-supply (2.5 V). R_1 is set to $1\text{ k}\Omega$ for bias current cancellation. The resistor divider costs less than the 2.5-V reference in Figure 70 but increases the current from the 5-V supply. Any noise or variation on the 5-V supply now also comes into the circuit as an input through the biasing path.

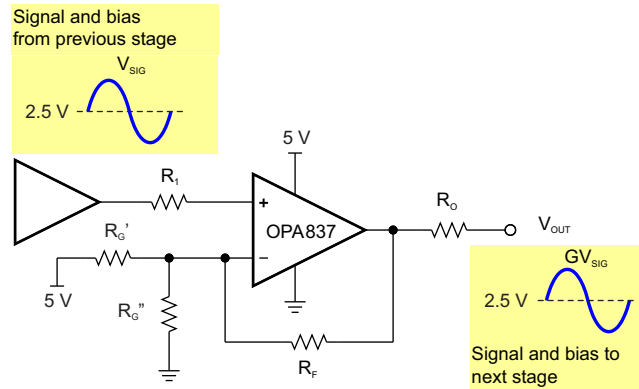

Figure 71. Noninverting Single-Supply Operation With Resistor Mid-Supply Biasing

Figure 72 shows a typical inverting amplifier circuit. With a 5-V single supply, a mid-supply reference generator is needed to bias the positive side through R_1 . To cancel the voltage offset that is otherwise caused by the input bias currents, R_1 is selected to be equal to R_F in parallel with R_G . For example, if a gain of -2 V/V is required and $R_F = 2\text{ k}\Omega$, select $R_G = 1\text{ k}\Omega$ to set the gain and $R_1 = 667\text{ }\Omega$ for bias current cancellation. The value for C is dependent on the reference, but TI recommends a value of at least $0.1\text{ }\mu\text{F}$ to limit noise into the op amp.

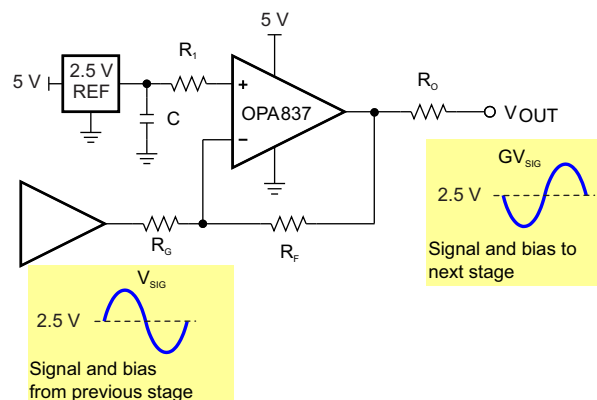

Figure 72. Inverting Single-Supply Operation With Reference

Device Functional Modes (continued)

Figure 73 shows a similar inverting single-supply scenario with the reference generator replaced by the Thevenin equivalent using resistors and the positive supply. R_1 and R_2 form a resistor divider from the 5-V supply and are used to bias the positive side. To cancel the voltage offset that is otherwise caused by the input bias currents, set the parallel value of R_1 and R_2 equal to the parallel value of R_F and R_G . C must be added to limit coupling of noise into the positive input. For example, if gain of -2 V/V is required and $R_F = 2$ k Ω , select $R_G = 1$ k Ω to set the gain. $R_1 = R_2 = 2 \times 667 \Omega = 1.33$ k Ω for the mid-supply voltage bias and for op-amp input-bias current cancellation. A good value for C is 0.1 μ F. The resistor divider costs less than the 2.5-V reference in Figure 72 but increases the current from the 5-V supply. Any noise or variation in the 5-V supply also comes into the circuit through this bias setup but be band-limited by the pole formed with $R_1 \parallel R_2$ and C .

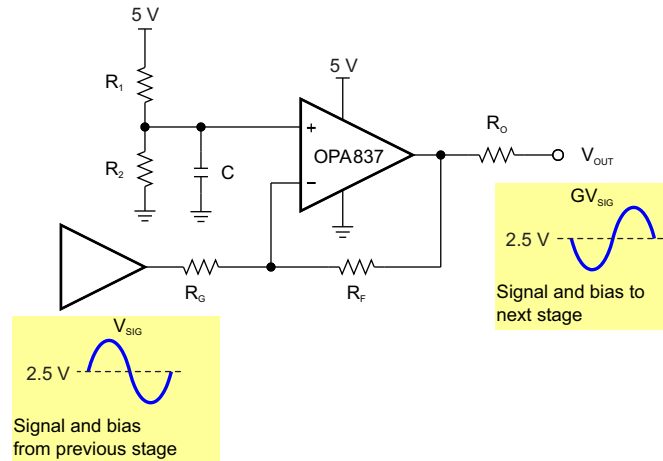

Figure 73. Inverting Single-Supply Operation With Resistor Midsupply Biasing

These examples are only a few of the ways to implement a single-supply design. Many other designs exist that can often be simpler if AC-coupled inputs are allowed. A good compilation of options can be found in the [Single-Supply Op Amp Design Techniques](#) application report.

8 Application and Implementation

NOTE

Information in the following applications sections is not part of the TI component specification, and TI does not warrant its accuracy or completeness. TI's customers are responsible for determining suitability of components for their purposes. Customers should validate and test their design implementation to confirm system functionality.

8.1 Application Information

8.1.1 Noninverting Amplifier

The OPAx837 can be used as a noninverting amplifier with a signal input to the noninverting input, V_{IN+} . A basic block diagram of the circuit is illustrated in Figure 62. V_{REF} is often ground when split supplies are used.

Calculate the amplifier output according to Equation 1 if $V_{IN} = V_{REF} + V_{SIG}$.

$$V_{OUT} = V_{SIG} \left(1 + \frac{R_F}{R_G} \right) + V_{REF} \quad (1)$$

The signal gain of the circuit is set by Equation 2, and V_{REF} provides a reference around which the input and output signals swing. Output signals are in-phase with the input signals within the flat portion of the frequency response. For a high-speed, low-noise device such as the OPAx837, the values selected for R_F (and R_G for the desired gain) can strongly influence the operation of the circuit. For the characteristic curves, the noninverting circuit of Figure 74 shows the test configuration set for a gain of 2 V/V. Table 2 lists the recommended resistor values over gain.

$$G = 1 + \frac{R_F}{R_G} \quad (2)$$

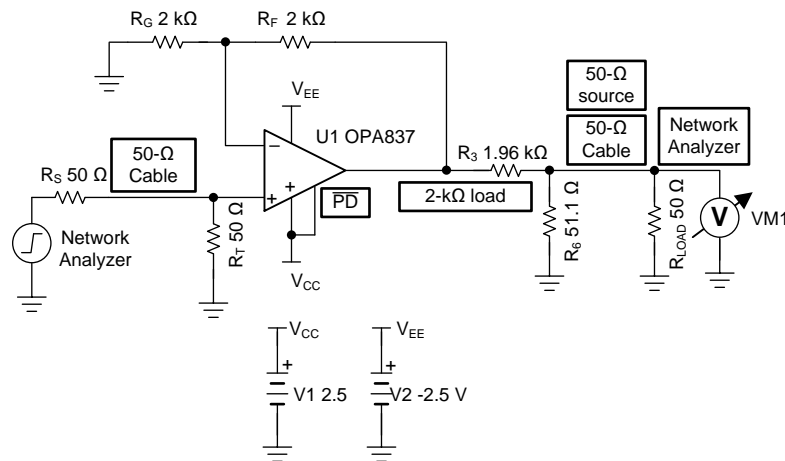

Figure 74. Characterization Test Circuit for Network, Spectrum Analyzer

Application Information (continued)

Table 2 lists the recommended resistor values from target gains of 1 V/V to 10 V/V where standard E96 values are shown. This table controls the R_F and R_G values to set the resistor noise contribution at approximately 50% of the total output noise power. These values increase the spot noise at the output over what the op amp voltage noise produces by 41%. Lower values reduce the output noise of any design at the cost of more power in the feedback circuit. Using the [TINA model and simulation tool](#) shows the impact of different resistor value choices on response shape and noise.

Table 2. Noninverting Recommended Resistor Values

TARGET GAIN (V/V)	R_F (Ω)	R_G (Ω)	ACTUAL GAIN (V/V)	GAIN (dB)
1	0	Open	1.00	0.00
1.5	1190	2370	1.50	3.53
2	2000	2000	2.00	6.02
3	2260	1130	3.00	9.54
4	2370	787	4.01	12.07
5	2490	619	5.02	14.02
6	2550	511	5.99	15.55
7	2610	432	7.04	16.95
8	2670	383	7.97	18.03
9	2670	332	9.04	19.13
10	2670	294	10.08	20.07

8.1.2 Inverting Amplifier

The OPAx837 can be used as an inverting amplifier with a signal input to the inverting input, V_{IN-} , through the gain-setting resistor R_G . A basic block diagram of the circuit is illustrated in [Figure 63](#).

The output of the amplifier can be calculated according to [Equation 3](#) if $V_{IN} = V_{REF} + V_{SIG}$ and the noninverting input is biased to V_{REF} .

$$V_{OUT} = V_{SIG} \left(\frac{-R_F}{R_G} \right) + V_{REF} \quad (3)$$

The signal gain of the circuit is set by Equation 4 and V_{REF} provides a reference point around which the input and output signals swing. For bipolar-supply operation, V_{REF} is often ground. The output signal is 180° out-of-phase with the input signal in the pass band of the application. Figure 75 shows the 50-Ω input matched configuration used for the inverting characterization plots set up for a gain of -1 V/V. In this case, an added termination resistor, R_T , is placed in parallel with the input R_G resistor to provide an impedance match to 50-Ω test equipment. The output network appears as a 2-kΩ load but with a 50-Ω source to the network analyzer. This output interface network does add a 37.9-dB insertion loss that is normalized out in the characterization curves. Table 3 lists the suggested values for R_F , R_G , and R_T for inverting gains from -0.5 V/V to -10 V/V. If a 50-Ω input match is not required, eliminate the R_T element.

$$G = \frac{-R_F}{R_G} \tag{4}$$

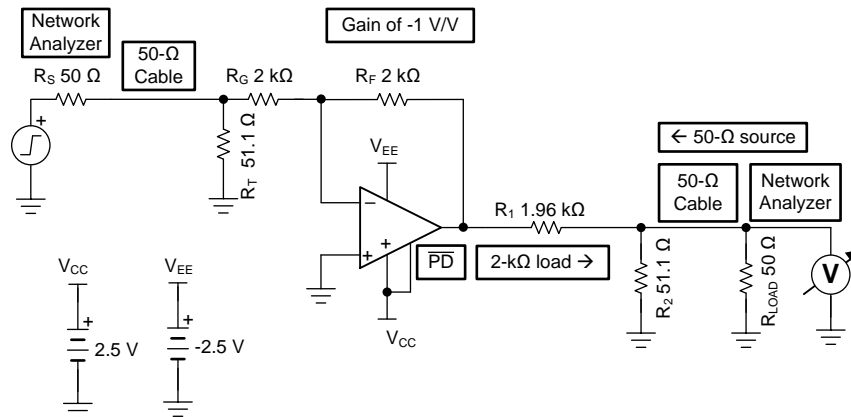

Figure 75. Inverting Characterization Circuit for Network Analyzer

Table 3. Inverting Recommended Resistor Values

INVERTING GAIN (V/V)	R_F (Ω)	R_G (Ω)	STANDARD R_T (Ω)	INPUT Z_i (Ω)	ACTUAL (V/V)	GAIN (dB)
-0.5	1190	2370	51.1	50.02	-0.50	-5.98
-1	2000	2000	51.1	49.83	-1.00	0.00
-2	2260	1130	52.3	49.99	-2.00	6.02
-3	2370	787	53.6	50.18	-3.01	9.58
-4	2490	619	54.9	50.43	-4.02	12.09
-5	2550	511	54.9	49.57	-4.99	13.96
-6	2610	432	56.2	49.73	-6.04	15.62
-7	2670	383	57.6	50.07	-6.97	16.87
-8	2670	332	59	50.10	-8.04	18.11
-9	2670	294	60.4	50.11	-9.08	19.16
-10	2670	267	61.9	50.25	-10.00	20.00

8.1.3 Output DC Error Calculations

The OPAx837 can provide excellent DC signal accuracy because of its high open-loop gain, high common-mode rejection, high power-supply rejection, and low input offset voltage and bias current offset errors. To take full advantage of this low input offset voltage, pay careful attention to input bias current cancellation. The low-noise input stage for the OPAx837 has a relatively high input bias current (0.34 μA typical out the pins) but with a close match between the two input currents. The OPAx837 is a negative rail input device using PNP input devices where the base current flows out of the device pins. A large resistor to ground on the V+ input shifts the pin voltage positively because of the input bias current. The mismatch between the two input bias currents is very low, typically only ± 10 nA of input offset current. Match the DC source impedances out of the two inputs to reduce the total output offset voltage. Figure 67 illustrates an example of resistor matching for bias current cancellation. Analyzing the simple circuit of Figure 67 (using a gain of 2-V/V target with $R_F = R_G = 2$ k Ω) illustrates that the noise gain for the input offset voltage drift is $1 + 2$ k Ω / 2 k Ω = 2 V/V. This value results in an output drift term of ± 1.6 $\mu\text{V}/^\circ\text{C} \times 2 = \pm 3.2$ $\mu\text{V}/^\circ\text{C}$ (DCK package). Because the two impedances out of the inputs are matched, the residual error from the maximum ± 250 pA/ $^\circ\text{C}$ offset current drift is this maximum I_{OS} drift times the 2-k Ω feedback resistor value, or ± 50 $\mu\text{V}/^\circ\text{C}$. The total output DC error drift band is ± 53.2 $\mu\text{V}/^\circ\text{C}$. If the output DC drift is more important than reduced feedback currents, lower the resistor values to reduce the dominant drift term resulting from the I_{OS} term.

8.1.4 Output Noise Calculations

The unity-gain stable, voltage-feedback OPAx837 op amp offers among the lowest input voltage and current noise terms for any device with a supply current less than 0.7 mA. Figure 76 shows the op amp noise analysis model that includes all noise terms. In this model, all noise terms are shown as noise voltage or current density terms in nV/ $\sqrt{\text{Hz}}$ or pA/ $\sqrt{\text{Hz}}$.

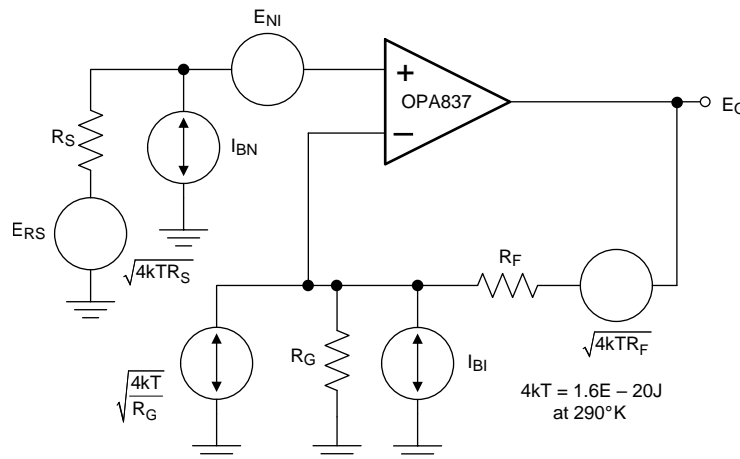

Figure 76. Op Amp Noise Analysis Model

The total output spot noise voltage is computed as the square root of the squared contributing terms to the output noise voltage. This computation is adding all the contributing noise powers at the output by superposition, then taking the square root to return to a spot noise voltage. The last term includes the noise for both the R_G and R_F resistors. Equation 5 shows the general form for this output noise voltage using the terms presented in Figure 76.

$$E_O = \sqrt{\left[E_{NI}^2 + (I_{BN}R_S)^2 + 4kTR_S \right] NG^2 + (I_{BI}R_F)^2 + 4kTR_F NG} \quad (5)$$

Dividing this expression by the noise gain ($NG = 1 + R_F / R_G$), as shown in Equation 6, gives the equivalent input referred spot noise voltage at the noninverting input.

$$E_N = \sqrt{E_{NI}^2 + (I_{BN}R_S)^2 + 4kTR_S + \left(\frac{I_{BI}R_F}{NG} \right)^2 + \frac{4kTR_F}{NG}} \quad (6)$$

Using the resistor values listed in [Table 2](#) with $R_S = 0 \Omega$ results in a constant input-referred voltage noise of $< 7 \text{ nV}/\sqrt{\text{Hz}}$. Reducing the resistor values can reduce this noise value towards the $4.7 \text{ nV}/\sqrt{\text{Hz}}$ intrinsic to the OPA837. As shown in [Equation 5](#), adding the R_S for bias current cancellation in noninverting mode adds the noise from the R_S to the total output noise. In inverting mode, bypass the R_S bias current cancellation resistor with a capacitor for the best noise performance. For more details on op amp noise analysis, see the [Noise Analysis for High-Speed Op Amps](#) application report.

8.1.5 Instrumentation Amplifier

[Figure 77](#) is an instrumentation amplifier that combines the high input impedance of the differential-to-differential amplifier circuit and the common-mode rejection of the differential-to-single-ended amplifier circuit. This circuit is often used in applications where high input impedance is required (such as taps from a differential line) or in cases where the signal source is a high impedance.

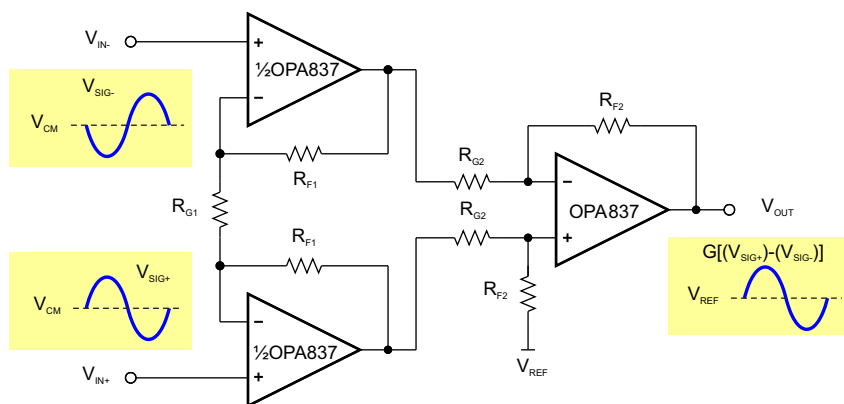

Figure 77. Instrumentation Amplifier (INA)

The output of the amplifier can be calculated according to [Equation 7](#) if $V_{IN+} = V_{CM} + V_{SIG+}$ and $V_{IN-} = V_{CM} + V_{SIG-}$.

$$V_{OUT} = (V_{IN+} - V_{IN-}) \times \left(1 + \frac{2R_{F1}}{R_{G1}} \right) \left(\frac{R_{F2}}{R_{G2}} \right) + V_{REF} \quad (7)$$

[Equation 8](#) shows the signal gain of the circuit. The input V_{CM} is rejected, and V_{REF} provides a reference voltage or level shift around which the output signal swings. The single-ended output signal is in-phase to the lower input signal polarity.

$$G = \left(1 + \frac{2R_{F1}}{R_{G1}} \right) \left(\frac{R_{F2}}{R_{G2}} \right) \quad (8)$$

Integrated INA solutions are available, but the OPAX837 device provides a high-frequency solution at relatively low power ($< 1.8 \text{ mA}$ for the three op-amp solution). For best CMRR performance, resistors must be matched. A good rule of thumb is $\text{CMRR} \approx$ the resistor tolerance; so a 0.1% tolerance provides approximately 60-dB CMRR. For higher gain INA implementations with higher bandwidths, apply the [OPA838](#) to the circuit of [Figure 77](#).

8.1.6 Attenuators

The noninverting circuit of [Figure 62](#) has a minimum gain of 1. To implement attenuation, a resistor divider can be placed in series with the positive input, and the amplifier set for a gain of 1 V/V by shorting V_{OUT} to V_{IN-} and removing R_G . Because the op amp input is high impedance, the resistor divider sets the attenuation.

The inverting circuit of [Figure 63](#) is used as an attenuator by making R_G larger than R_F . The attenuation is the resistor ratio. For example, a 10:1 attenuator can be implemented with $R_F = 2 \text{ k}\Omega$ and $R_G = 20 \text{ k}\Omega$.

8.1.7 Differential to Single-Ended Amplifier

Figure 78 shows a differential amplifier that converts differential signals to single-ended in a single stage and provides gain (or attenuation) and level shifting. This circuit can be used in applications such as a line receiver for converting a differential signal from a Cat5 cable to a single-ended output signal.

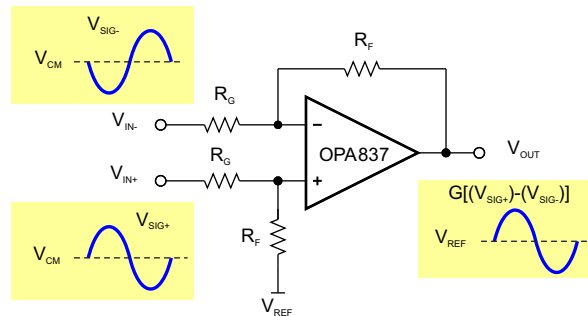

Figure 78. Differential to Single-Ended Amplifier

The output of the amplifier can be calculated according to Equation 9 if $V_{IN+} = V_{CM} + V_{SIG+}$ and $V_{IN-} = V_{CM} + V_{SIG-}$.

$$V_{OUT} = (V_{IN+} - V_{IN-}) \times \left(\frac{R_F}{R_G} \right) + V_{REF} \quad (9)$$

The signal gain of the circuit is shown in Equation 10, V_{CM} is rejected, and V_{REF} provides a level shift or reference voltage around which the output signal swings. The single-ended output signal is in-phase with the noninverting input signal. V_{REF} is often ground when split supplies are used on the op amp.

$$G = \frac{R_F}{R_G} \quad (10)$$

Line termination can be accomplished by adding a shunt resistor across the V_{IN+} and V_{IN-} inputs. The differential impedance is the shunt resistance in parallel with the input impedance of the amplifier circuit, which is usually much higher. For low gain and low line impedance, the resistor value to add is approximately the impedance of the line. For example, if a 100- Ω Cat5 cable is used with a gain of 1 V/V amplifier and $R_F = R_G = 2 \text{ k}\Omega$, adding a 100- Ω shunt across the input gives a differential impedance of 99 Ω , which is an adequate match for most applications.

For best CMRR performance, resistors must be matched. Assuming $CMRR \approx$ the resistor tolerance, a 0.1% tolerance provides approximately 60-dB CMRR.

8.1.8 Differential-to-Differential Amplifier

Figure 79 shows a differential amplifier that is used to amplify differential signals to a differential output. This circuit has high input impedance and is used in differential line driver applications where the signal source is a high-impedance driver (for example, a differential DAC) that must drive a line.

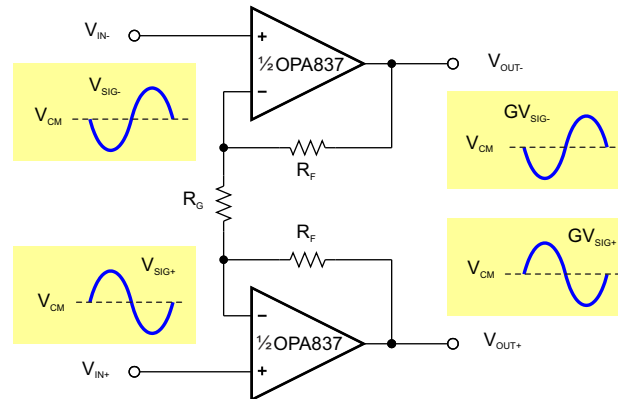

Figure 79. Differential-to-Differential Amplifier

The output of the amplifier can be calculated according to Equation 11 if $V_{IN\pm}$ is set to $V_{CM} + V_{SIG\pm}$.

$$V_{OUT\pm} = V_{IN\pm} \times \left(1 + \frac{2R_F}{R_G} \right) + V_{CM} \quad (11)$$

The signal gain of the circuit is shown in Equation 12, and V_{CM} passes with unity gain. The amplifier combines two noninverting amplifiers into one differential amplifier that shares the R_G resistor, which makes R_G effectively half its value when calculating the gain. The output signals are in-phase with the input signals.

$$G = 1 + \frac{2R_F}{R_G} \quad (12)$$

8.1.9 Pulse Application With Single-Supply Circuit

For pulsed applications where the signal is at ground and pulses to a positive or negative voltage, the circuit bias-voltage considerations differ from those in an application with a signal that swings symmetrically around a reference point. Figure 80 shows a circuit where the signal is at ground (0 V) and pulses to a positive value. The waveforms are shown slightly above ground because the output stage requires approximately 100 mV headroom to the supplies. To operate with the I/O swing truly to ground on a single-supply setup, consider using the fixed -0.23-V output LM7705.

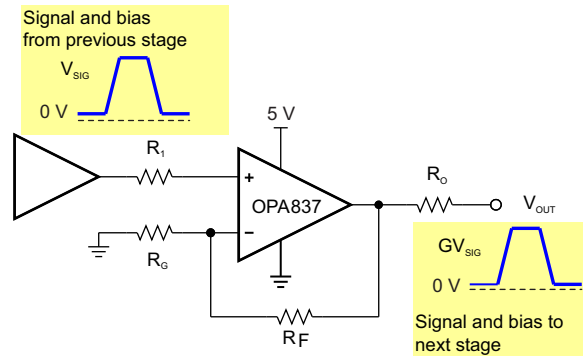

Figure 80. Noninverting Single-Supply Circuit With Pulse

As shown in Figure 81, an inverting amplifier is more appropriate if the input signal pulses negative from ground. A key consideration in noninverting and inverting cases is that the input and output voltages are kept within the limits of the amplifier. Because the V_{ICR} of the OPA837 includes the negative supply rail, the OPA837 op amp is well-suited for this application.

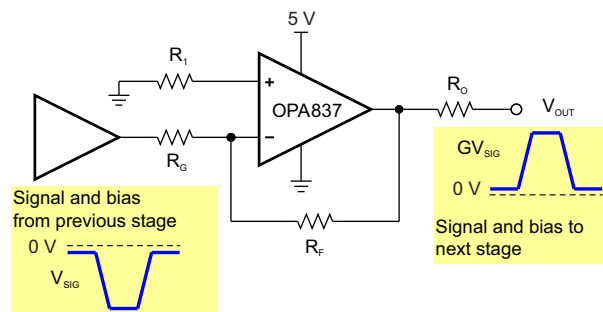

Figure 81. Inverting Single-Supply Circuit With Pulse

8.1.10 ADC Driver Performance

The OPAx837 provides excellent performance when driving high-performance delta-sigma ($\Delta\Sigma$) or successive-approximation-register (SAR) ADCs in low-power audio and industrial applications.

Figure 82 repeats the front page diagram. Many designs prefer to work with a true 0-V input range to 0-V output at the ADC. The 100-mV output headroom requirement for the OPAx837 then requires a small negative supply to hold the output linearity to ground. This supply is provided in this example using the low-cost LM7705 fixed negative, -0.23-V output regulator. On a 5-V supply, the input headroom requires at least a 1.2-V headroom to that supply. As shown in Figure 82, this requirement limits the maximum input to 3.8 V. The SAR operates with a precision 4.096-V reference provided by the REF5040, where the gain of 1.05 V/V takes the 3.8-V maximum input to a 4.0-V maximum output. The RC values have been set to limit the overshoot at the OPAx837 output pin to reduce clipping on fast (50 ns) transitions.

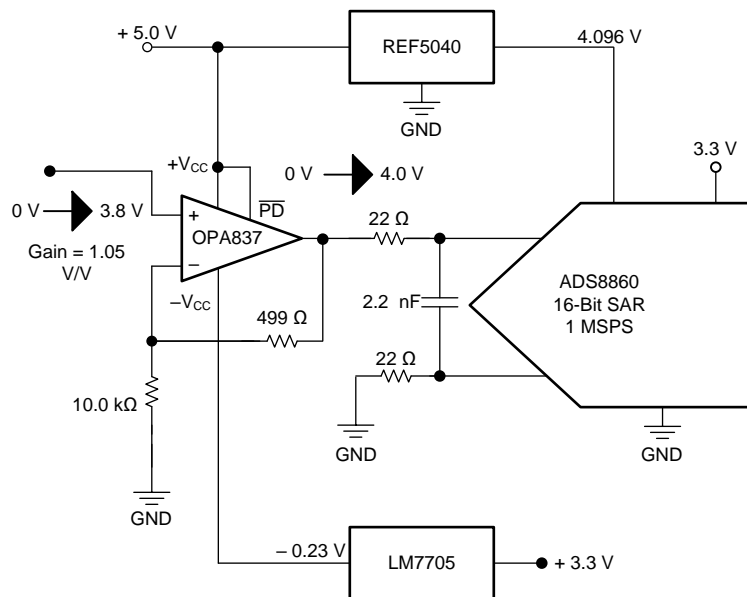

Figure 82. OPA837 and ADS8860 Example Circuit

8.2 Typical Applications

8.2.1 Active Filters

The OPAx837 is a good choice for active filters. [Figure 83](#) and [Figure 84](#) show MFB and Sallen-Key circuits designed implementing second-order, low-pass Butterworth filter circuits. [Figure 85](#) illustrates the frequency response.

The main difference is that the MFB active filter provides an inverting amplifier in the pass band and the Sallen-Key active filter is noninverting. The primary advantage for each active filter is that the Sallen-Key filter in unity gain has no resistor gain error term or feedback resistor noise contribution. The MFB active filter has better attenuation properties beyond the bandwidth of the op amp. The example circuits are assuming a split-supply operation but single-supply operation is possible with midscale biasing.

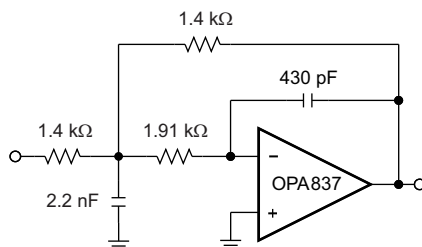

Figure 83. MFB Active Filter, 100-kHz, Second-Order, Low-Pass Butterworth Filter Circuit

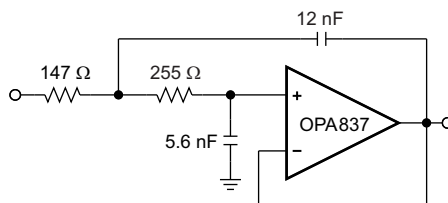

Figure 84. Sallen-Key Active Filter, 100-kHz, Second-Order, Low-Pass Butterworth Filter Circuit

8.2.1.1 Design Requirements

For both designs, target the following filter shape characteristic:

- Gain of 1 V/V
- 100-kHz Butterworth response
- $Q = 0.707$ gives a flat Butterworth design

Scale the resistors down to reduce their noise contribution. In the MFB design, the input resistor is the in-band load to the prior stage. Use values slightly below the gain of -1 V/V in [Table 3](#). The Sallen-Key filter shows a high impedance input in-band, so scale those resistors down further to improve noise.

The output DC error and drift can be improved by adding bias current cancellation resistors. For the MFB filter that is a resistor (and a noise filter capacitor) on the noninverting input to ground equal to the resistor inside the loop times the noise gain. For the Sallen-Key design, add a feedback resistor equal to the sum of the two input resistors.

8.2.1.2 Detailed Design Procedure

The filter designs shown in this section used an improved design flow that reduces the resistor noise and noise gain peaking. For the MFB filter, the design was based on the information in the [Design Methodology for MFB Filters in ADC Interface Applications](#) application note.

For the Sallen-Key design, the solution is based on the information in the [Component Pre-Distortion for Sallen Key Filters](#) application note.

Typical Applications (continued)

8.2.1.3 Application Curves

Figure 85 shows the comparative response curves for each of the filter design examples. Both filters hit the desired response shape exactly. However, notice the loss of stop-band rejection in the Sallen-Key design. This loss results from the op amp output impedance increasing at higher frequencies and allowing the signal to feed through the feedback capacitor to the output.

Figure 86 shows a comparison of the output spot noise for the two designs. The Sallen-Key is much lower because of the lower resistor values used. Also, the MFB shows a noise gain of 2 V/V versus the Sallen-Key gain of 1 V/V. This difference immediately increases the MFB output noise by at least twice the input voltage noise from the op amp. The higher resistor values also increase the total output noise for the MFB.

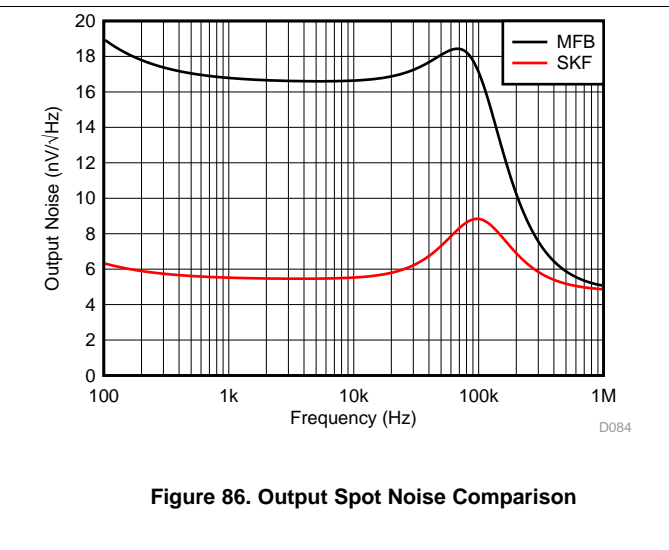
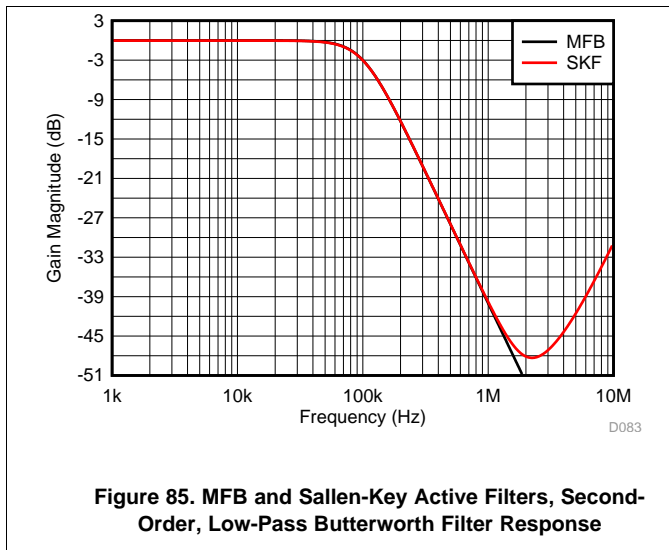

8.2.2 Implementing a 2:1 Active Multiplexer

The OPA837 includes a unique feature that enables a much improved wired-or mux operation. When disabled, an internal switch opens from the inverting input to the active transistors isolating those nonlinear loads from the signal being driven back into the inverting input through the active channel. Figure 87 illustrates a simple example of this multiplexer. In this figure, one of two signals are selected to be passed on to a shared output. The logic control turns both amplifiers off (logic low) prior to turning one of them on. This control eliminates both outputs being active at the same time. If both amplifiers must be on, as in the simple switch illustrated in Figure 87, adding 100-Ω isolating resistors inside the loop at the outputs limits the current flow when both amplifiers are turned on. This solution offers a very high input impedance to both inputs, very low buffered output drive, and nearly perfect channel-to-channel isolation. The example of Figure 87 also includes a -0.23-V supply generator to allow true swing to ground on the output pins. This negative supply generator is optional if the outputs are more than 0.1 V above ground or intended to be AC-coupled. Testing with a single channel active and an off channel attached to the output showed no degradation in harmonic distortion; see Figure 17 and Figure 35. This approach can be expanded to more than two channels or to operate with gain in the channels. Adding more than two select channels in parallel should add 100-Ω feedback resistors to isolate the inverting input capacitance from the active output channel.

Typical Applications (continued)

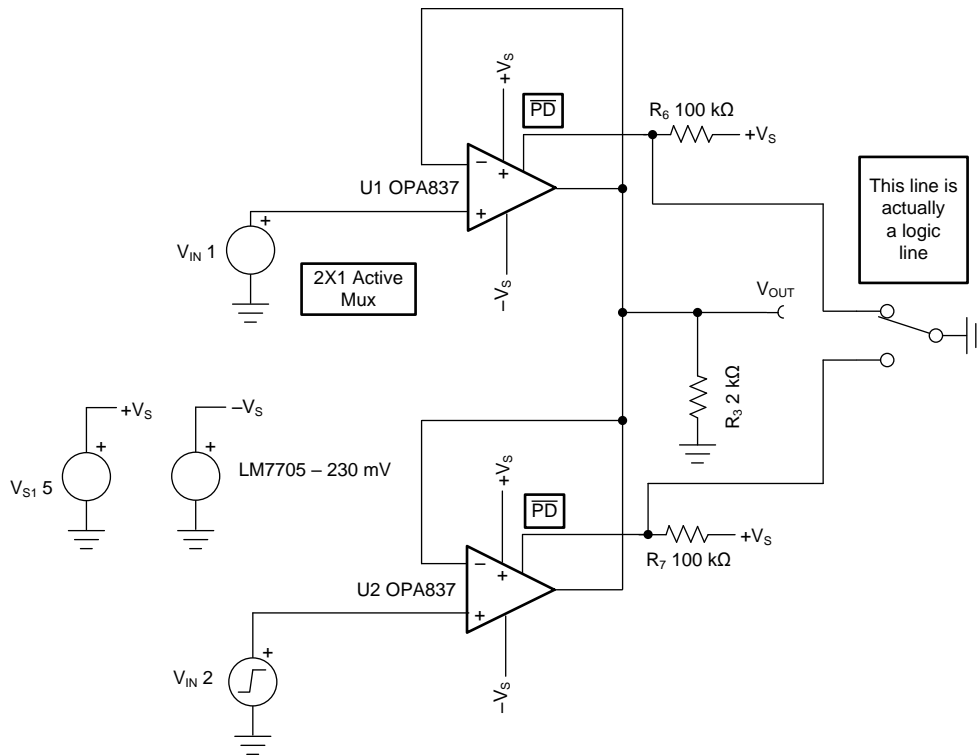

Figure 87. 2:1 Active Multiplexer

8.2.2.1 Design Requirements

To implement a 2:1 active mux, connect the outputs of two OPA837 devices together with separate input signals. If termination is required for the input signals, add this termination as a resistor to ground on the noninverting inputs. The inputs accept an input range from 0 V to 3.8 V by using a negative 0.23-V supply generator, such as the LM7705.

8.2.2.2 Detailed Design Procedure

Aside from simply connecting the two outputs together as shown in Figure 87, there are several other considerations as well:

- If the source impedance is not 0 Ω , consider adding a resistor in the feedback networks equal to that source impedance to reduce the output DC error resulting from bias currents
- If the logic control can place both channels on at the same time, place 100- Ω resistors inside the feedback loop to limit supply currents when both outputs are active
- If a matched gain is desired for the two inputs, configure the op amps for that gain instead of gain of 1 V/V
- If the load is capacitive, add the required R_{OUT} before the summing point on each op amp output

Typical Applications (continued)

8.2.3 1-Bit PGA Operation

Using the internal inverting input switch that operates along with the power disable function can also allow a simple gain selection on a single input signal. Figure 88 shows an example gain select of either 1 V/V or 2 V/V from a single input to a single output. The logic disables both channels before turning one of them on to avoid high currents in both outputs to be active at the same time. If this approach is not possible, as in the simple switch shown in Figure 88, insert 100- Ω resistors inside the loop of each op amp output. A bipolar supply is shown in Figure 88, but any of the single-supply options are also possible. Any combination of gains can be implemented, but wide gain ranges show a larger change in signal bandwidth. This approach can be expanded to more than two gain settings. Testing with the circuit of Figure 88 showed no change in harmonic distortion; see Figure 18 and Figure 36.

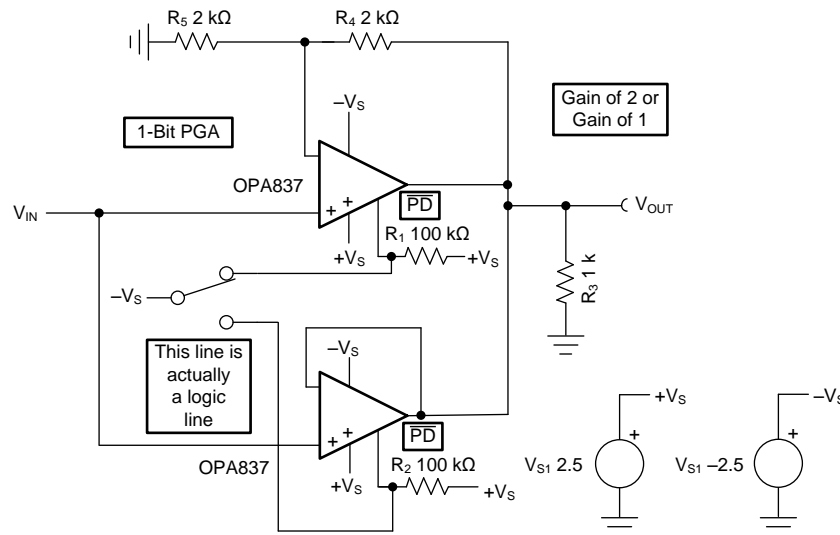

Figure 88. 1-Bit PGA

8.2.3.1 Design Requirements

Configure two OPA837 device outputs in different gains when driving the noninverting input with the same input signal. Select one of the two channels using the disable control. Set one channel to a gain of 1 V/V and the second channel to a gain of 2 V/V using the recommended 2-k Ω values from Table 2.

8.2.3.2 Detailed Design Procedure

The simple design of Figure 88 has several options and details to consider, which include:

- For split-supply operation, the disable control line must operate to within 0.55 V of the negative supply to disable a channel. A logic level shift is required.
- Any combination of gains can be implemented. However, the signal bandwidths may vary widely through the gain bandwidth product effect between the two channels if the gains are widely separated. If a more constant bandwidth between gains is desired, consider adding a fixed RC filter after the combined outputs at a lower cutoff frequency than the slowest gain setting.

The [TIDA-01565 Wired OR MUX and PGA Reference Design](#) demonstrates the use of the OPAx837 in wired-OR multiplexer and programmable gain amplifier applications.

9 Power Supply Recommendations

The OPAx837 is intended to work in a nominal supply range of 3.0 V to 5 V. Supply-voltage tolerances are supported with the specified operating range of 2.7 V (–10% on a 3-V supply) and 5.4 V (+8% on a 5-V supply). Good power-supply bypassing is required. Minimize the distance (< 0.1 inch) from the power-supply pins to high-frequency, 0.1- μ F decoupling capacitors. A larger capacitor (2.2 μ F is typical) is used along with a high-frequency, 0.1- μ F supply-decoupling capacitor at the device supply pins. For single-supply operation, only the positive supply has these capacitors. When a split supply is used, use these capacitors for each supply to ground. If necessary, place the larger capacitors further from the device and share these capacitors among several devices in the same area of the printed circuit board (PCB). Avoid narrow power and ground traces to minimize inductance between the pins and the decoupling capacitors. An optional supply decoupling capacitor across the two power supplies (for bipolar operation) reduces second harmonic distortion.

The OPA837 has a positive supply current temperature coefficient; see [Figure 57](#). This coefficient helps improve the input offset voltage drift. Supply current requirements in the system design must account for this effect using the maximum intended ambient and [Figure 57](#) to size the supply required. The very low power dissipation for the OPA837 typically does not require any special thermal design considerations. For the extreme case of 125°C operating ambient, use the approximate maximum 200°C/W for the two packages, and a maximum internal power of 5.4-V supply \times 0.8-mA 125°C supply current from [Figure 57](#) gives a maximum internal power of 4.3 mW. This power only gives a 0.86°C rise from ambient to junction temperature, which is well below the maximum 150°C junction temperature. Load power adds to this value, but also increases the junction temperature only slightly over ambient temperature.

10 Layout

10.1 Layout Guidelines

The [OPA837EVM](#) can be used as a reference when designing the circuit board. TI recommends following the EVM layout of the external components near to the amplifier, ground plane construction, and power routing as closely as possible. General guidelines are listed below:

1. Signal routing must be direct and as short as possible into and out of the op amp.
2. The feedback path must be short and direct avoiding vias if possible, especially with $G = 1$ V/V.
3. Ground or power planes must be removed from directly under the negative input and output pins of the amplifier.
4. TI recommends placing a series output resistor as close to the output pin as possible. See [Figure 49](#) for recommended values for the expected capacitive load. These values are derived targeting a 30° phase margin to the output of the op amp.
5. A 2.2- μ F power-supply decoupling capacitor must be placed within two inches of the device and can be shared with other op amps. For split supply, a capacitor is required for both supplies.
6. A 0.1- μ F power-supply decoupling capacitor must be placed as close to the supply pins as possible, preferably within 0.1 inch. For split supply, a capacitor is required for both supplies.
7. The \overline{PD} pin uses low logic swing levels. If the pin is not used, \overline{PD} must be tied to the positive supply to enable the amplifier. If the pin is used, \overline{PD} must be actively driven. A bypass capacitor is not necessary, but can be used for robustness in noisy environments.

10.2 Layout Example

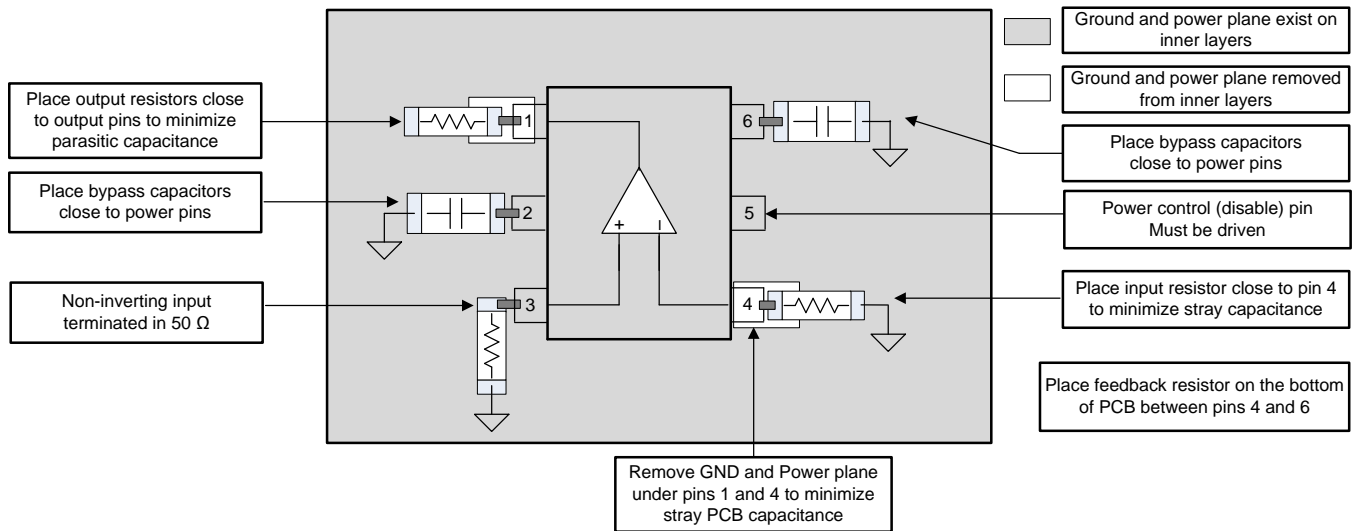

Figure 89. EVM Layout Example

11 Device and Documentation Support

11.1 Documentation Support

11.1.1 Related Documentation

For related documentation see the following:

- Texas Instruments, [ADS8860 16-Bit, 1-MSPS, Serial Interface, microPower, Miniature, Single-Ended Input, SAR Analog-to-Digital Converter data sheet](#)
- Texas Instruments, [LM7705 Low-Noise Negative Bias Generator data sheet](#)
- Texas Instruments, [OPA838 1-mA, 300-MHz Gain Bandwidth, Voltage-Feedback Op Amp data sheet](#)
- Texas Instruments, [REF50xx Low-Noise, Very Low Drift, Precision Voltage Reference data sheet](#)
- Texas Instruments, [OPA837DBV, OPA836DBV EVM user's guide](#)
- Texas Instruments, [Single-Supply Op Amp Design Techniques application report](#)
- Texas Instruments, [Noise Analysis for High-Speed Op Amps application report](#)
- Texas Instruments, [Design Methodology for MFB Filters in ADC Interface Applications application note](#)
- Texas Instruments, [Component Pre-Distortion for Sallen Key Filters application note](#)
- Texas Instruments, [TIDA-01565 Wired OR MUX and PGA Reference Design design guide](#)
- Texas Instruments, [TINA model and simulation tool](#)

11.2 Related Links

The table below lists quick access links. Categories include technical documents, support and community resources, tools and software, and quick access to order now.

Table 4. Related Links

PARTS	PRODUCT FOLDER	ORDER NOW	TECHNICAL DOCUMENTS	TOOLS & SOFTWARE	SUPPORT & COMMUNITY
OPA837	Click here	Click here	Click here	Click here	Click here
OPA2837	Click here	Click here	Click here	Click here	Click here

11.3 Receiving Notification of Documentation Updates

To receive notification of documentation updates, navigate to the device product folder on ti.com. In the upper right corner, click on *Alert me* to register and receive a weekly digest of any product information that has changed. For change details, review the revision history included in any revised document.

11.4 Community Resources

The following links connect to TI community resources. Linked contents are provided "AS IS" by the respective contributors. They do not constitute TI specifications and do not necessarily reflect TI's views; see TI's [Terms of Use](#).

TI E2E™ Online Community *TI's Engineer-to-Engineer (E2E) Community*. Created to foster collaboration among engineers. At e2e.ti.com, you can ask questions, share knowledge, explore ideas and help solve problems with fellow engineers.

Design Support *TI's Design Support* Quickly find helpful E2E forums along with design support tools and contact information for technical support.

11.5 Trademarks

E2E is a trademark of Texas Instruments.
All other trademarks are the property of their respective owners.

11.6 Electrostatic Discharge Caution



These devices have limited built-in ESD protection. The leads should be shorted together or the device placed in conductive foam during storage or handling to prevent electrostatic damage to the MOS gates.

11.7 Glossary

[SLYZ022](#) — *TI Glossary*.

This glossary lists and explains terms, acronyms, and definitions.

12 Mechanical, Packaging, and Orderable Information

The following pages include mechanical, packaging, and orderable information. This information is the most current data available for the designated devices. This data is subject to change without notice and revision of this document. For browser-based versions of this data sheet, refer to the left-hand navigation.

PACKAGING INFORMATION

Orderable Device	Status (1)	Package Type	Package Drawing	Pins	Package Qty	Eco Plan (2)	Lead finish/ Ball material (6)	MSL Peak Temp (3)	Op Temp (°C)	Device Marking (4/5)	Samples
OPA2837IDGKR	ACTIVE	VSSOP	DGK	8	2500	RoHS & Green	NIPDAUAG SN	Level-2-260C-1 YEAR	-40 to 125	2837	Samples
OPA2837IDGKT	ACTIVE	VSSOP	DGK	8	250	RoHS & Green	NIPDAUAG SN	Level-2-260C-1 YEAR	-40 to 125	2837	Samples
OPA2837IRUNR	ACTIVE	QFN	RUN	10	3000	RoHS & Green	NIPDAU	Level-2-260C-1 YEAR	-40 to 125	2837	Samples
OPA2837IRUNT	ACTIVE	QFN	RUN	10	250	RoHS & Green	NIPDAU	Level-2-260C-1 YEAR	-40 to 125	2837	Samples
OPA837IDBVR	ACTIVE	SOT-23	DBV	6	3000	RoHS & Green	NIPDAU	Level-2-260C-1 YEAR	-40 to 125	19FF	Samples
OPA837IDBVR2	ACTIVE	SOT-23	DBV	6	3000	RoHS & Green	NIPDAU	Level-2-260C-1 YEAR	-40 to 125	19FF	Samples
OPA837IDBVT	ACTIVE	SOT-23	DBV	6	250	RoHS & Green	NIPDAU	Level-2-260C-1 YEAR	-40 to 125	19FF	Samples
OPA837IDCKR	ACTIVE	SC70	DCK	5	3000	RoHS & Green	NIPDAU	Level-2-260C-1 YEAR	-40 to 125	16K	Samples
OPA837IDCKT	ACTIVE	SC70	DCK	5	250	RoHS & Green	NIPDAU	Level-2-260C-1 YEAR	-40 to 125	16K	Samples

(1) The marketing status values are defined as follows:

ACTIVE: Product device recommended for new designs.

LIFEBUY: TI has announced that the device will be discontinued, and a lifetime-buy period is in effect.

NRND: Not recommended for new designs. Device is in production to support existing customers, but TI does not recommend using this part in a new design.

PREVIEW: Device has been announced but is not in production. Samples may or may not be available.

OBSOLETE: TI has discontinued the production of the device.

(2) **RoHS:** TI defines "RoHS" to mean semiconductor products that are compliant with the current EU RoHS requirements for all 10 RoHS substances, including the requirement that RoHS substance do not exceed 0.1% by weight in homogeneous materials. Where designed to be soldered at high temperatures, "RoHS" products are suitable for use in specified lead-free processes. TI may reference these types of products as "Pb-Free".

RoHS Exempt: TI defines "RoHS Exempt" to mean products that contain lead but are compliant with EU RoHS pursuant to a specific EU RoHS exemption.

Green: TI defines "Green" to mean the content of Chlorine (Cl) and Bromine (Br) based flame retardants meet JS709B low halogen requirements of <=1000ppm threshold. Antimony trioxide based flame retardants must also meet the <=1000ppm threshold requirement.

(3) MSL, Peak Temp. - The Moisture Sensitivity Level rating according to the JEDEC industry standard classifications, and peak solder temperature.

(4) There may be additional marking, which relates to the logo, the lot trace code information, or the environmental category on the device.

⁽⁵⁾ Multiple Device Markings will be inside parentheses. Only one Device Marking contained in parentheses and separated by a "~" will appear on a device. If a line is indented then it is a continuation of the previous line and the two combined represent the entire Device Marking for that device.

⁽⁶⁾ Lead finish/Ball material - Orderable Devices may have multiple material finish options. Finish options are separated by a vertical ruled line. Lead finish/Ball material values may wrap to two lines if the finish value exceeds the maximum column width.

Important Information and Disclaimer:The information provided on this page represents TI's knowledge and belief as of the date that it is provided. TI bases its knowledge and belief on information provided by third parties, and makes no representation or warranty as to the accuracy of such information. Efforts are underway to better integrate information from third parties. TI has taken and continues to take reasonable steps to provide representative and accurate information but may not have conducted destructive testing or chemical analysis on incoming materials and chemicals. TI and TI suppliers consider certain information to be proprietary, and thus CAS numbers and other limited information may not be available for release.

In no event shall TI's liability arising out of such information exceed the total purchase price of the TI part(s) at issue in this document sold by TI to Customer on an annual basis.

TAPE AND REEL INFORMATION

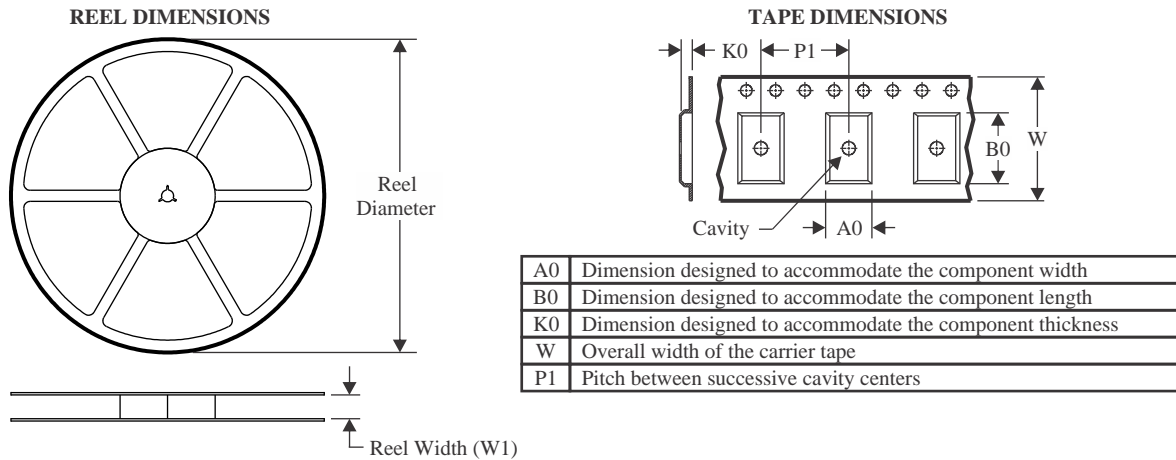

QUADRANT ASSIGNMENTS FOR PIN 1 ORIENTATION IN TAPE

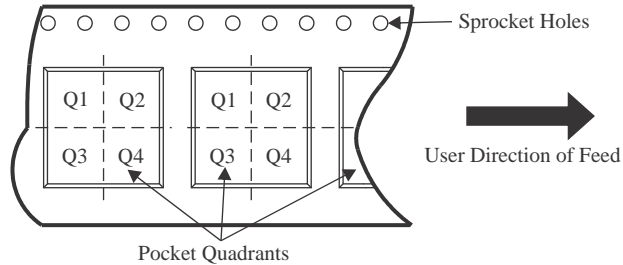

*All dimensions are nominal

Device	Package Type	Package Drawing	Pins	SPQ	Reel Diameter (mm)	Reel Width W1 (mm)	A0 (mm)	B0 (mm)	K0 (mm)	P1 (mm)	W (mm)	Pin1 Quadrant
OPA2837IDGKR	VSSOP	DGK	8	2500	330.0	12.4	5.3	3.4	1.4	8.0	12.0	Q1
OPA2837IDGKT	VSSOP	DGK	8	250	330.0	12.4	5.3	3.4	1.4	8.0	12.0	Q1
OPA2837IRUNR	QFN	RUN	10	3000	180.0	8.4	2.3	2.3	1.15	4.0	8.0	Q2
OPA2837IRUNT	QFN	RUN	10	250	180.0	8.4	2.3	2.3	1.15	4.0	8.0	Q2
OPA837IDBVR	SOT-23	DBV	6	3000	178.0	9.0	3.23	3.17	1.37	4.0	8.0	Q3
OPA837IDBVR2	SOT-23	DBV	6	3000	178.0	9.0	3.23	3.17	1.37	4.0	8.0	Q2
OPA837IDBVT	SOT-23	DBV	6	250	178.0	9.0	3.23	3.17	1.37	4.0	8.0	Q3
OPA837IDCKR	SC70	DCK	5	3000	178.0	9.0	2.4	2.5	1.2	4.0	8.0	Q3
OPA837IDCKT	SC70	DCK	5	250	178.0	9.0	2.4	2.5	1.2	4.0	8.0	Q3

TAPE AND REEL BOX DIMENSIONS

*All dimensions are nominal

Device	Package Type	Package Drawing	Pins	SPQ	Length (mm)	Width (mm)	Height (mm)
OPA2837IDGKR	VSSOP	DGK	8	2500	366.0	364.0	50.0
OPA2837IDGKT	VSSOP	DGK	8	250	366.0	364.0	50.0
OPA2837IRUNR	QFN	RUN	10	3000	210.0	185.0	35.0
OPA2837IRUNT	QFN	RUN	10	250	210.0	185.0	35.0
OPA837IDBVR	SOT-23	DBV	6	3000	180.0	180.0	18.0
OPA837IDBVR2	SOT-23	DBV	6	3000	180.0	180.0	18.0
OPA837IDBVT	SOT-23	DBV	6	250	180.0	180.0	18.0
OPA837IDCKR	SC70	DCK	5	3000	180.0	180.0	18.0
OPA837IDCKT	SC70	DCK	5	250	180.0	180.0	18.0

DCK0005A



PACKAGE OUTLINE

SOT - 1.1 max height

SMALL OUTLINE TRANSISTOR

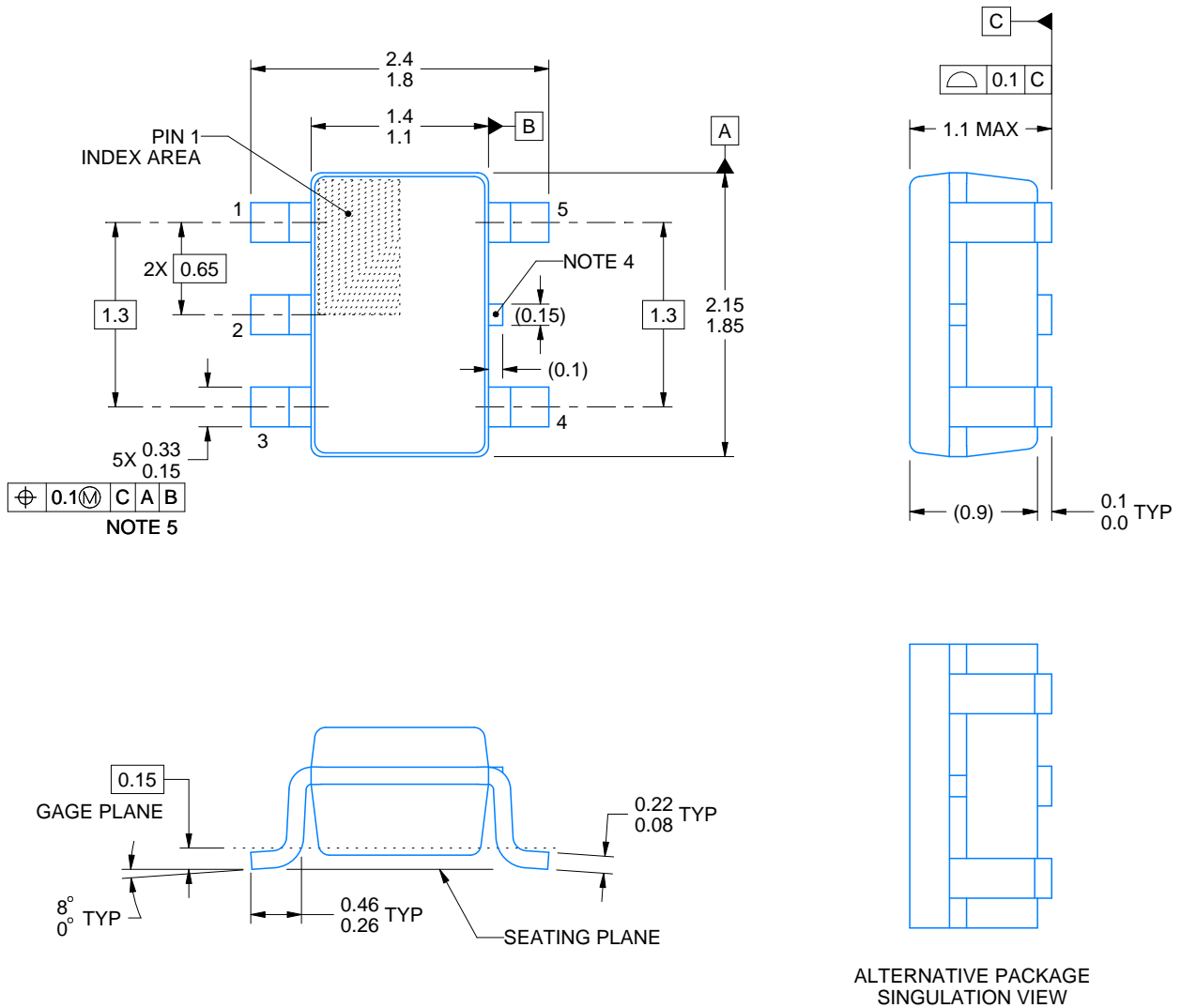

4214834/E 06/2024

NOTES:

1. All linear dimensions are in millimeters. Any dimensions in parenthesis are for reference only. Dimensioning and tolerancing per ASME Y14.5M.
2. This drawing is subject to change without notice.
3. Reference JEDEC MO-203.
4. Support pin may differ or may not be present.
5. Lead width does not comply with JEDEC.
6. Body dimensions do not include mold flash, protrusions, or gate burrs. Mold flash, protrusions, or gate burrs shall not exceed 0.25mm per side

EXAMPLE BOARD LAYOUT

DCK0005A

SOT - 1.1 max height

SMALL OUTLINE TRANSISTOR

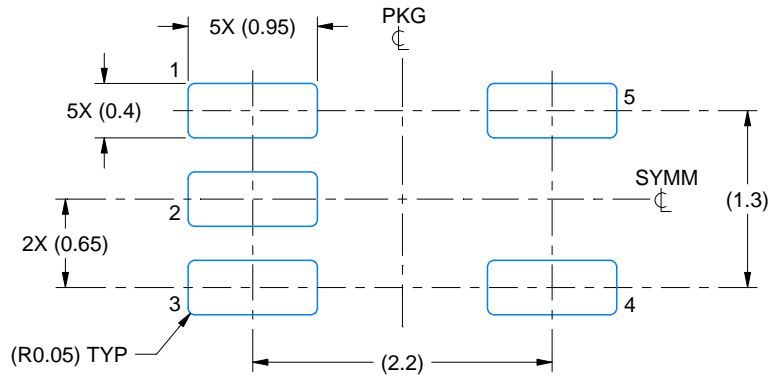

LAND PATTERN EXAMPLE
EXPOSED METAL SHOWN
SCALE:18X

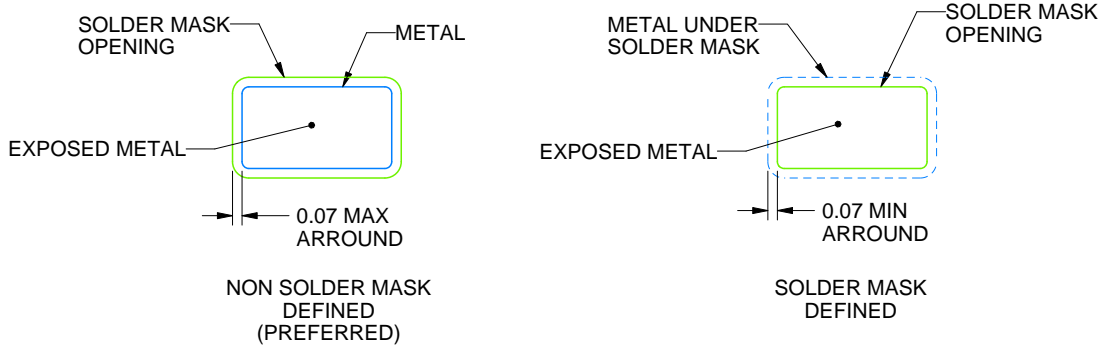

SOLDER MASK DETAILS

4214834/E 06/2024

NOTES: (continued)

- 7. Publication IPC-7351 may have alternate designs.
- 8. Solder mask tolerances between and around signal pads can vary based on board fabrication site.

EXAMPLE STENCIL DESIGN

DCK0005A

SOT - 1.1 max height

SMALL OUTLINE TRANSISTOR

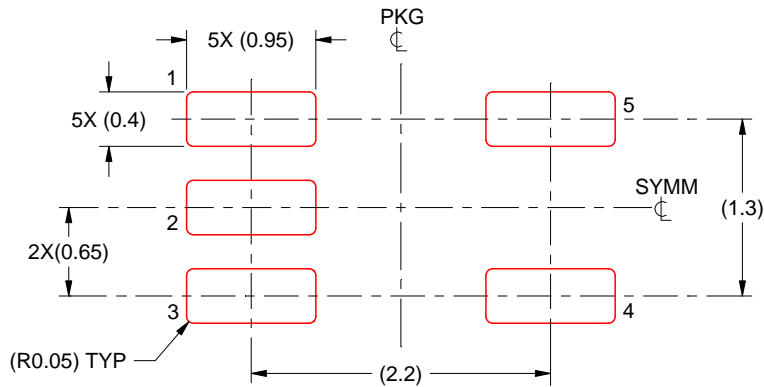

SOLDER PASTE EXAMPLE
BASED ON 0.125 THICK STENCIL
SCALE: 18X

4214834/E 06/2024

NOTES: (continued)

9. Laser cutting apertures with trapezoidal walls and rounded corners may offer better paste release. IPC-7525 may have alternate design recommendations.
10. Board assembly site may have different recommendations for stencil design.

DGK0008A



PACKAGE OUTLINE

VSSOP - 1.1 mm max height

SMALL OUTLINE PACKAGE



4214862/A 04/2023

NOTES:

PowerPAD is a trademark of Texas Instruments.

1. All linear dimensions are in millimeters. Any dimensions in parenthesis are for reference only. Dimensioning and tolerancing per ASME Y14.5M.
2. This drawing is subject to change without notice.
3. This dimension does not include mold flash, protrusions, or gate burrs. Mold flash, protrusions, or gate burrs shall not exceed 0.15 mm per side.
4. This dimension does not include interlead flash. Interlead flash shall not exceed 0.25 mm per side.
5. Reference JEDEC registration MO-187.

EXAMPLE BOARD LAYOUT

DGK0008A

™ VSSOP - 1.1 mm max height

SMALL OUTLINE PACKAGE

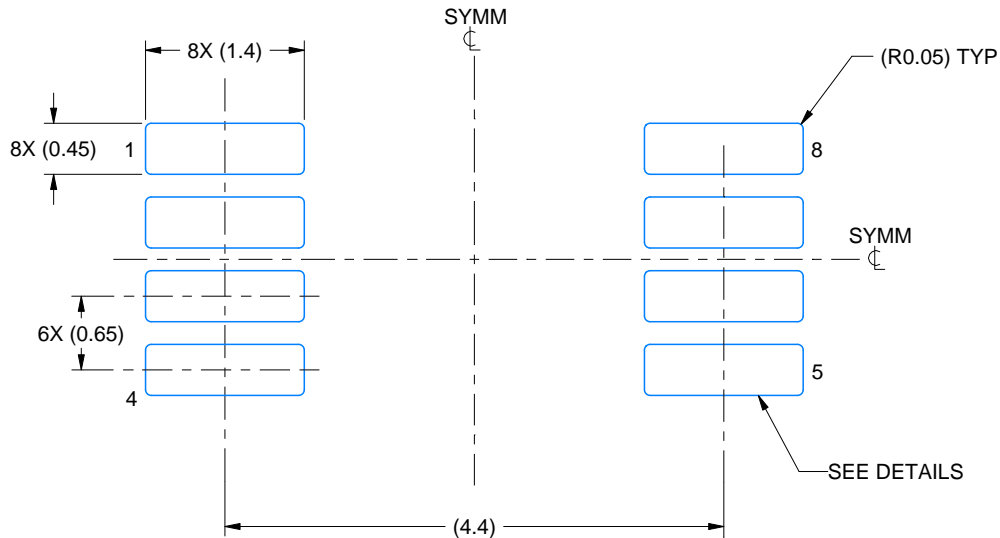

LAND PATTERN EXAMPLE
EXPOSED METAL SHOWN
SCALE: 15X

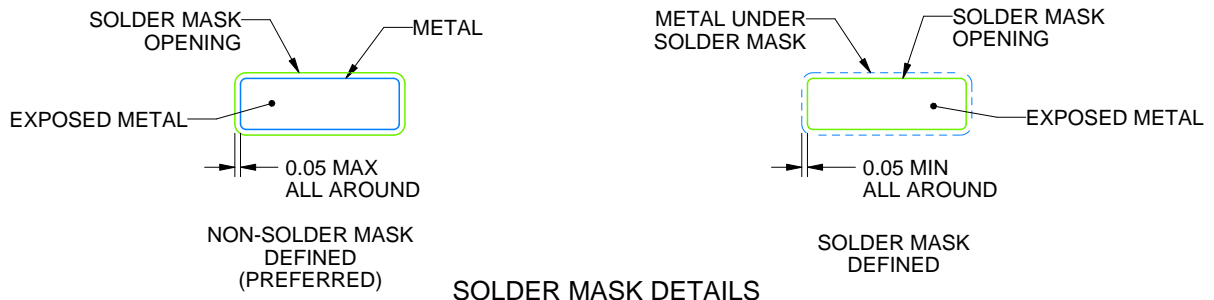

SOLDER MASK DETAILS

4214862/A 04/2023

NOTES: (continued)

6. Publication IPC-7351 may have alternate designs.
7. Solder mask tolerances between and around signal pads can vary based on board fabrication site.
8. Vias are optional depending on application, refer to device data sheet. If any vias are implemented, refer to their locations shown on this view. It is recommended that vias under paste be filled, plugged or tented.
9. Size of metal pad may vary due to creepage requirement.

EXAMPLE STENCIL DESIGN

DGK0008A

TM VSSOP - 1.1 mm max height

SMALL OUTLINE PACKAGE

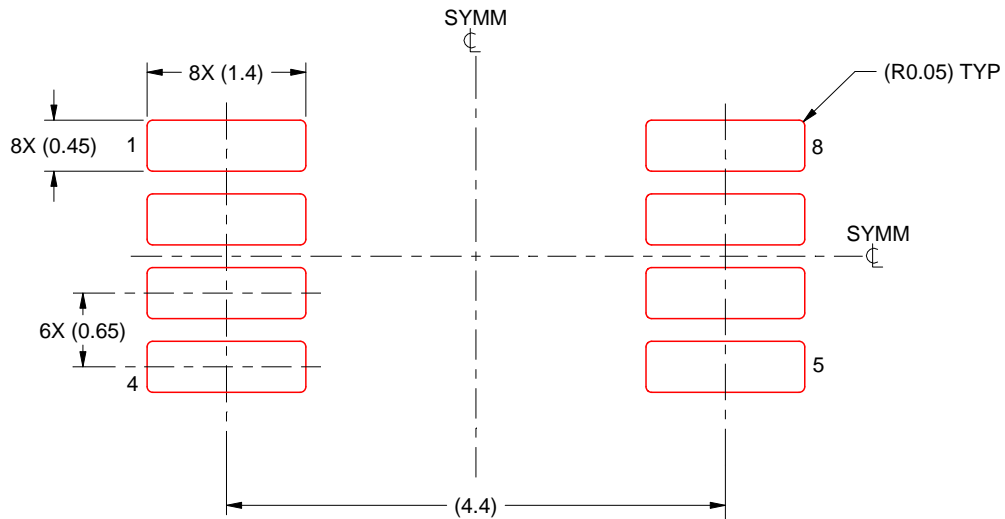

SOLDER PASTE EXAMPLE
SCALE: 15X

4214862/A 04/2023

NOTES: (continued)

11. Laser cutting apertures with trapezoidal walls and rounded corners may offer better paste release. IPC-7525 may have alternate design recommendations.
12. Board assembly site may have different recommendations for stencil design.

GENERIC PACKAGE VIEW

RUN 10

WQFN - 0.8 mm max height

2 X 2, 0.5 mm pitch

PLASTIC QUAD FLATPACK - NO LEAD

This image is a representation of the package family, actual package may vary.
Refer to the product data sheet for package details.

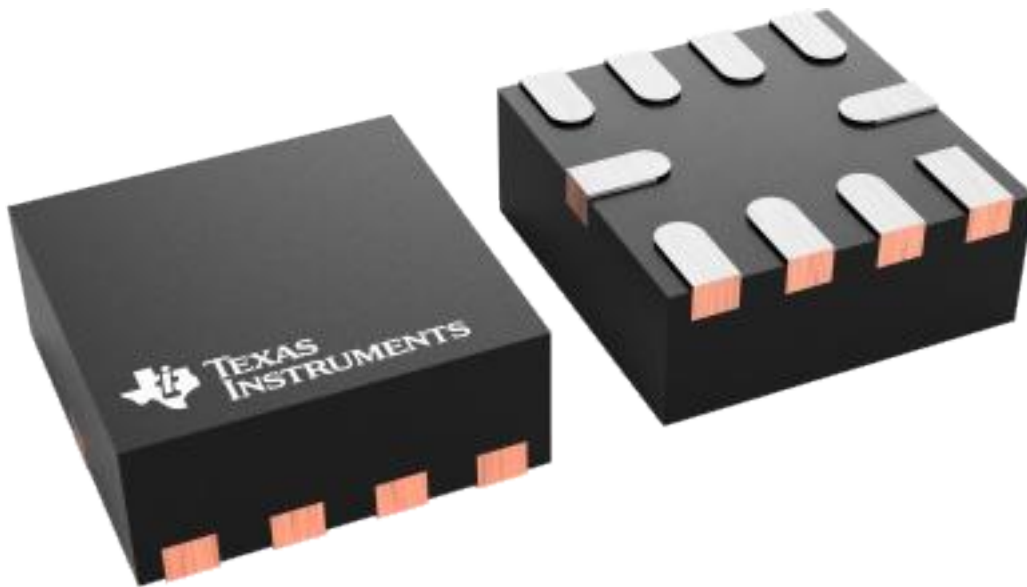

4228249/A

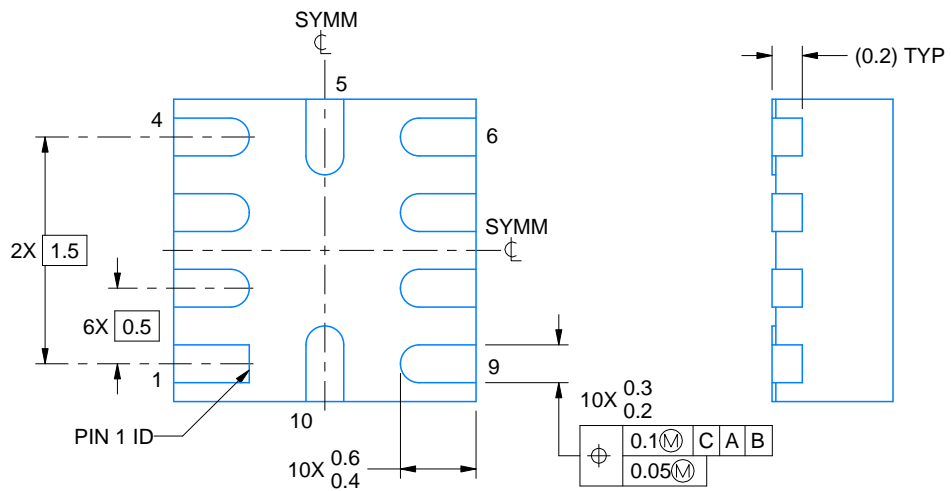
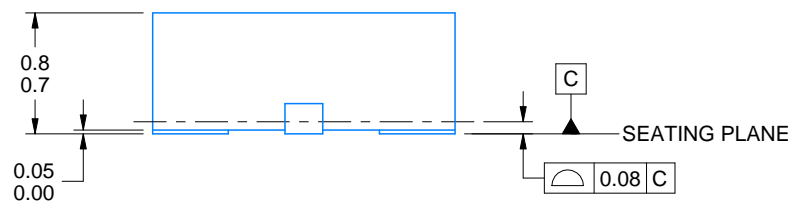
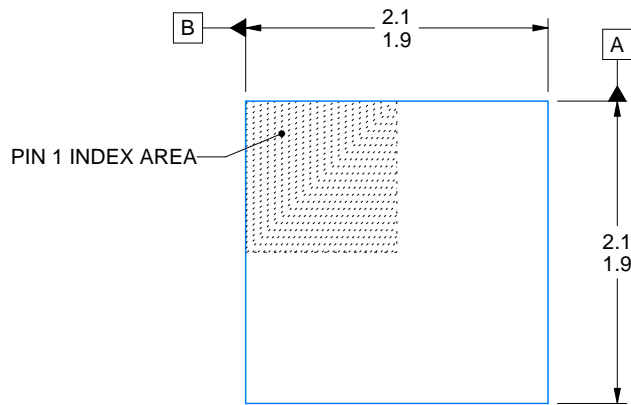
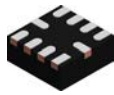

4220470/A 05/2020

NOTES:

1. All linear dimensions are in millimeters. Any dimensions in parenthesis are for reference only. Dimensioning and tolerancing per ASME Y14.5M.
2. This drawing is subject to change without notice.

EXAMPLE BOARD LAYOUT

RUN0010A

WQFN - 0.8 mm max height

PLASTIC QUAD FLATPACK - NO LEAD

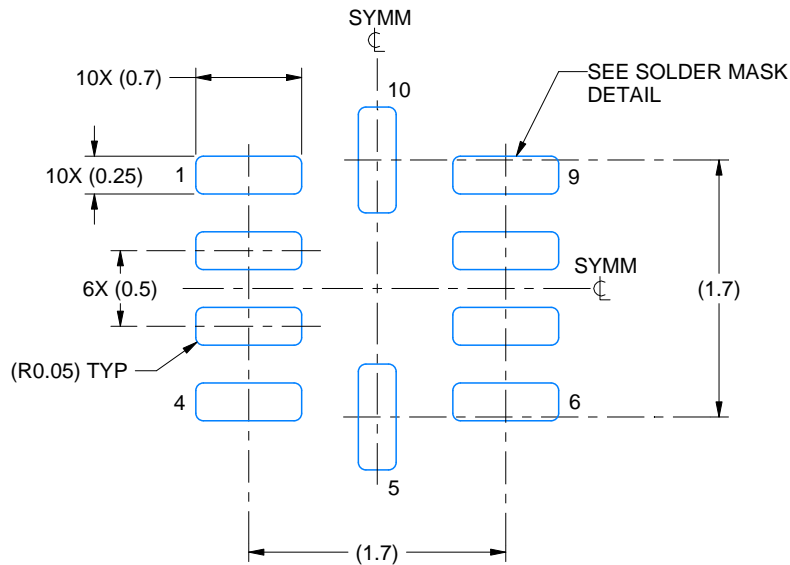

LAND PATTERN EXAMPLE
EXPOSED METAL SHOWN
SCALE: 20X

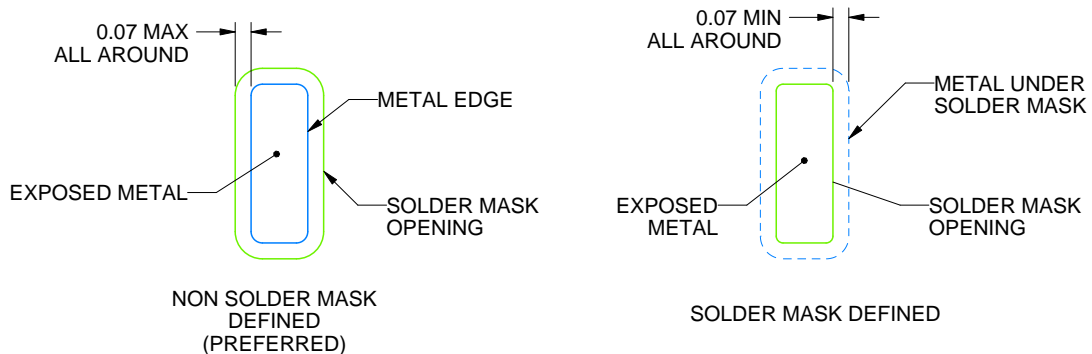

SOLDER MASK DETAILS

4220470/A 05/2020

NOTES: (continued)

- This package is designed to be soldered to a thermal pad on the board. For more information, see Texas Instruments literature number SLUA271 (www.ti.com/lit/slua271).

EXAMPLE STENCIL DESIGN

RUN0010A

WQFN - 0.8 mm max height

PLASTIC QUAD FLATPACK - NO LEAD

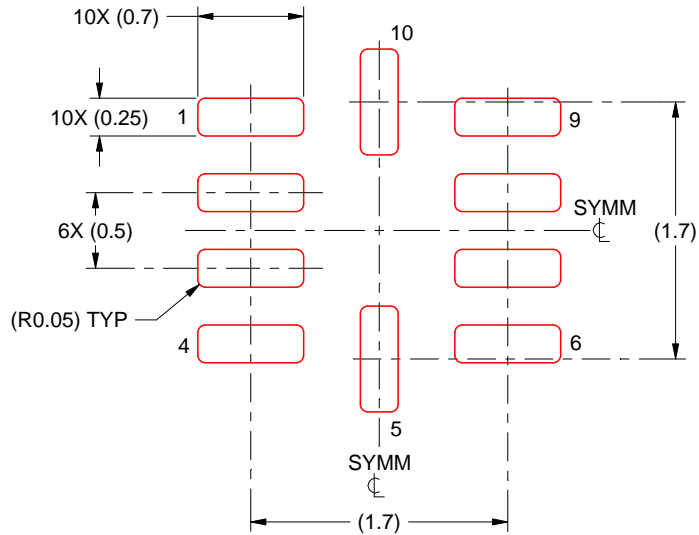

SOLDER PASTE EXAMPLE
BASED ON 0.125 MM THICK STENCIL
SCALE: 20X

4220470/A 05/2020

NOTES: (continued)

4. Laser cutting apertures with trapezoidal walls and rounded corners may offer better paste release. IPC-7525 may have alternate design recommendations.

EXAMPLE BOARD LAYOUT

DBV0006A

SOT-23 - 1.45 mm max height

SMALL OUTLINE TRANSISTOR

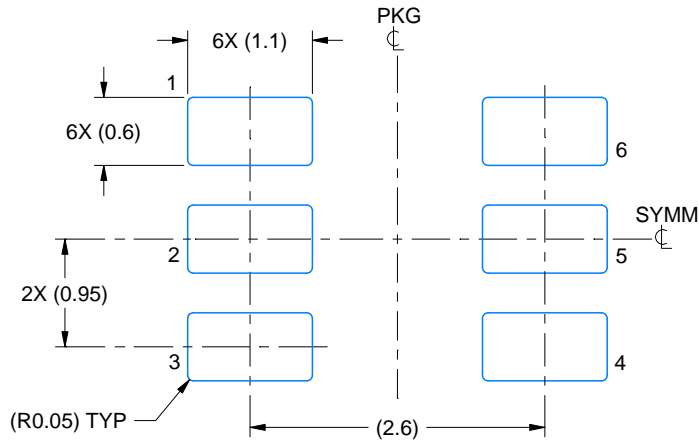

LAND PATTERN EXAMPLE
EXPOSED METAL SHOWN
SCALE:15X

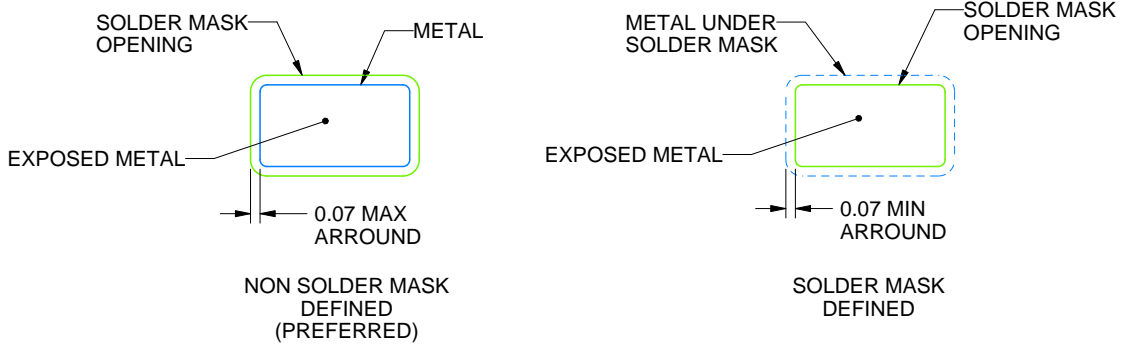

SOLDER MASK DETAILS

4214840/F 05/2024

NOTES: (continued)

6. Publication IPC-7351 may have alternate designs.
7. Solder mask tolerances between and around signal pads can vary based on board fabrication site.

EXAMPLE STENCIL DESIGN

DBV0006A

SOT-23 - 1.45 mm max height

SMALL OUTLINE TRANSISTOR

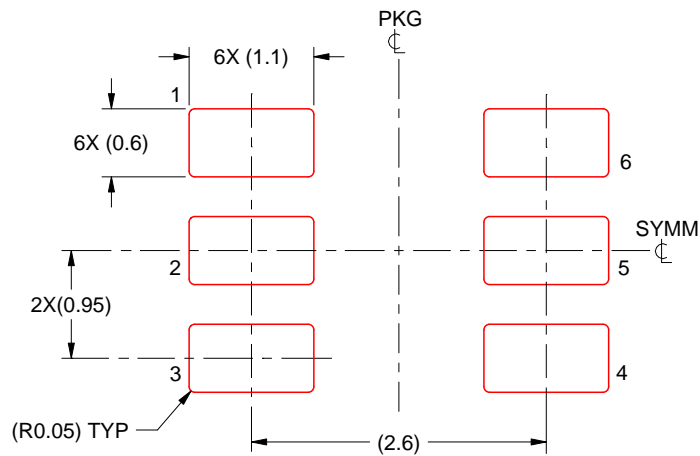

SOLDER PASTE EXAMPLE
BASED ON 0.125 mm THICK STENCIL
SCALE:15X

4214840/F 05/2024

NOTES: (continued)

8. Laser cutting apertures with trapezoidal walls and rounded corners may offer better paste release. IPC-7525 may have alternate design recommendations.
9. Board assembly site may have different recommendations for stencil design.

IMPORTANT NOTICE AND DISCLAIMER

TI PROVIDES TECHNICAL AND RELIABILITY DATA (INCLUDING DATA SHEETS), DESIGN RESOURCES (INCLUDING REFERENCE DESIGNS), APPLICATION OR OTHER DESIGN ADVICE, WEB TOOLS, SAFETY INFORMATION, AND OTHER RESOURCES "AS IS" AND WITH ALL FAULTS, AND DISCLAIMS ALL WARRANTIES, EXPRESS AND IMPLIED, INCLUDING WITHOUT LIMITATION ANY IMPLIED WARRANTIES OF MERCHANTABILITY, FITNESS FOR A PARTICULAR PURPOSE OR NON-INFRINGEMENT OF THIRD PARTY INTELLECTUAL PROPERTY RIGHTS.

These resources are intended for skilled developers designing with TI products. You are solely responsible for (1) selecting the appropriate TI products for your application, (2) designing, validating and testing your application, and (3) ensuring your application meets applicable standards, and any other safety, security, regulatory or other requirements.

These resources are subject to change without notice. TI grants you permission to use these resources only for development of an application that uses the TI products described in the resource. Other reproduction and display of these resources is prohibited. No license is granted to any other TI intellectual property right or to any third party intellectual property right. TI disclaims responsibility for, and you will fully indemnify TI and its representatives against, any claims, damages, costs, losses, and liabilities arising out of your use of these resources.

TI's products are provided subject to [TI's Terms of Sale](#) or other applicable terms available either on [ti.com](https://www.ti.com) or provided in conjunction with such TI products. TI's provision of these resources does not expand or otherwise alter TI's applicable warranties or warranty disclaimers for TI products.

TI objects to and rejects any additional or different terms you may have proposed.

Mailing Address: Texas Instruments, Post Office Box 655303, Dallas, Texas 75265
Copyright © 2024, Texas Instruments Incorporated

Looking for pricing, stock, or lifecycle information?

Click below to explore more details on WIN SOURCE:

 [View 1744426-6 on WIN SOURCE](#)

 [TE Connectivity](#) Information

Optimize Your Supply Chain with WIN SOURCE Solutions

-  Global Sourcing Solution
-  Obsolete Management
-  Cost Control Management
-  Shortage Management
-  Alternative Solution
-  Excess Inventory Management