



THE DATASHEET OF BMC156



Data sheet

BMC156

6-axis eCompass

Bosch Sensortec



BOSCH
Invented for life



BMC156: Data sheet

Document revision 1.0

Document release date 16 July 2014

Document number BST-BMC156-DS000-01

Technical reference code(s) 0 273 141 193

Notes Data in this document are subject to change without notice. Product photos and pictures are for illustration purposes only and may differ from the real product's appearance.
Not intended for publishing.

BMC156

ECOMPASS WITH 3-AXIS GEOMAGNETIC SENSOR AND 12 BIT 3-AXIS ACCELEROMETER

Key features

Three-axis magnetic field sensor and 12bit three-axis accelerometer in one package

- Accelerometer can still be used independently from magnetometer operation
- Ultra-Small package 12-Pin LGA package, footprint $2.2 \times 2.2\text{mm}^2$, height 0.95 mm
- Digital interface SPI (4-wire, 3-wire), I²C, 2 interrupt pins (1 acceleration sensor, 1 magnetic sensor interrupt pin)
- Low voltage operation V_{DD} supply voltage range: 1.62V to 3.6V
 V_{DDIO} interface voltage range: 1.2V to 3.6V
- Flexible functionality Acceleration ranges $\pm 2g/\pm 4g/\pm 8g/\pm 16g$
Acceleration Low-pass filter bandwidths 1 kHz - <8Hz
- Magnetic field range $\pm 1300\mu\text{T}$ (x, y-axis), $\pm 2500\mu\text{T}$ (z-axis)
Magnetic field resolution of $\sim 0.3\mu\text{T}$
- On-chip FIFO Integrated FIFO with a depth of 32 frames
- On-chip interrupt controller Motion-triggered interrupt-signal generation for
 - new data (separate for accelerometer and magnetometer)
 - any-motion (slope) detection
 - tap sensing (single tap / double tap)
 - orientation recognition
 - flat detection
 - low-g/high-g detection
- Ultra-low power Low current consumption (190 μA @ 10 Hz including accelerometer and magnetic sensor in low power preset), short wake-up time, advanced features for system power management
- Temperature range -40 °C ... +85 °C
- Temperature sensor
- RoHS compliant, halogen-free

Typical applications

- Tilt-compensated electronic compass for map rotation, navigation and augmented reality
- 6-axis orientation for gaming
- Display profile switching
- Menu scrolling, tap / double tap sensing
- Pedometer / step counting
- Free-fall detection
- Drop detection for warranty logging
- Advanced system power management for mobile applications
- Gaming

General Description

The BMC156 is an integrated electronic compass solution for consumer market applications. It comprises a 12bit leading edge triaxial, low-g acceleration sensor and an ultra-low power, high precision triaxial magnetic field sensor. It allows measurements of acceleration and magnetic field in three perpendicular axes. Performance and features of both sensing technologies are carefully tuned and perfectly match the demanding requirements of all 6-axis mobile applications such as electronic compass, navigation or augmented reality.

An evaluation circuitry (ASIC) converts the output of the micromechanical sensing structures (MEMS) to digital results which can be read out over the industry standard digital interfaces.

Package and interfaces of the BMC156 have been designed to match a multitude of hardware requirements. As the sensor features an ultra-small footprint and a flat package, it is ingeniously suited for mobile applications.

The BMC156 offers ultra-low voltage operation (V_{DD} voltage range from 1.62V to 3.6V, V_{DDIO} voltage range 1.2V to 3.6V) and can be programmed to optimize functionality, performance and power consumption in customer specific applications. The programmable interrupt engine sets new standards in terms of flexibility.

The BMC156 senses orientation, tilt, motion, shock, vibration and heading in cell phones, handhelds, computer peripherals, man-machine interfaces, virtual reality features and game controllers.

Index of Contents

1. SPECIFICATION	7
1.1 COMPASS ELECTRICAL SPECIFICATION	7
1.2 ACCELEROMETER SPECIFICATION	8
1.3 MAGNETOMETER SPECIFICATION	11
2. ABSOLUTE MAXIMUM RATINGS	15
3. BLOCK DIAGRAM	16
4. FUNCTIONAL DESCRIPTION.....	17
4.1 SUPPLY VOLTAGE AND POWER MANAGEMENT	17
4.2 POWER MODES.....	17
4.2.1 ACCELEROMETER POWER MODES	18
4.2.2 MAGNETOMETER POWER MODES	22
4.2.3 BMC156 OVERALL POWER CONSUMPTION	25
4.3 SENSOR DATA	26
4.3.1 ACCELERATION DATA	26
4.3.2 TEMPERATURE SENSOR.....	27
4.3.3 MAGNETIC FIELD DATA.....	27
4.3.4 MAGNETIC FIELD DATA TEMPERATURE COMPENSATION.....	29
4.4 SELF-TEST	30
4.4.1 ACCELEROMETER SELF-TEST.....	30
4.4.2 MAGNETOMETER SELF-TEST	31
4.5 ACCELEROMETER OFFSET COMPENSATION.....	33
4.5.1 SLOW COMPENSATION.....	35
4.5.2 FAST COMPENSATION.....	35
4.5.3 MANUAL COMPENSATION	36
4.5.4 INLINE CALIBRATION	36
4.6 NON-VOLATILE MEMORY	37
4.6.1 ACCELEROMETER NON-VOLATILE MEMORY	37
4.6.2 MAGNETOMETER NON-VOLATILE MEMORY	37
4.7 ACCELEROMETER INTERRUPT CONTROLLER	38
4.7.1 GENERAL FEATURES	38
4.7.2 MAPPING TO PHYSICAL INTERRUPT PINS (INTTYPE TO INT PIN#)	39
4.7.3 ELECTRICAL BEHAVIOR (INT PIN# TO OPEN-DRIVE OR PUSH-PULL).....	40
4.7.4 NEW DATA INTERRUPT.....	40
4.7.5 SLOPE / ANY-MOTION DETECTION.....	41
4.7.6 TAP SENSING	43
4.7.7 ORIENTATION RECOGNITION	46
4.7.8 FLAT DETECTION.....	51
4.7.9 LOW-G INTERRUPT	52
4.7.10 HIGH-G INTERRUPT	53
4.7.11 NO-MOTION / SLOW MOTION DETECTION	54

4.8 ACCELEROMETER SOFTRESET 56

4.9 MAGNETOMETER INTERRUPT CONTROLLER 57

 4.9.1 GENERAL FEATURES 57

 4.9.2 ELECTRICAL BEHAVIOR OF MAGNETIC INTERRUPT PIN 57

 4.9.3 DATA READY / DRDY INTERRUPT 57

5. FIFO OPERATION.....59

 5.1 FIFO OPERATING MODES 59

 5.2 FIFO DATA READOUT 60

 5.3 FIFO FRAME COUNTER AND OVERRUN FLAG 60

 5.4 FIFO INTERRUPTS 61

6. ACCELEROMETER REGISTER DESCRIPTION.....62

 6.1 GENERAL REMARKS 62

 6.2 REGISTER MAP 63

 6.3 CHIP ID..... 64

 6.4 ACCELERATION DATA 65

 6.5 TEMPERATURE DATA..... 71

 6.6 STATUS REGISTERS 72

 6.7 G-RANGE SELECTION..... 77

 6.8 BANDWIDTHS..... 78

 6.9 POWER MODES..... 79

 6.10 SPECIAL CONTROL SETTINGS..... 81

 6.11 INTERRUPT SETTINGS..... 83

 6.12 SELF-TEST 97

 6.13 NON-VOLATILE MEMORY CONTROL (EEPROM)..... 98

 6.14 INTERFACE CONFIGURATION 99

 6.15 OFFSET COMPENSATION..... 100

 6.16 NON-VOLATILE MEMORY BACK-UP 104

 6.17 FIFO CONFIGURATION AND FIFO DATA 105

7. MAGNETOMETER REGISTER DESCRIPTION107

 7.1 GENERAL REMARKS 107

 7.2 REGISTER MAP 107

 7.3 CHIP ID..... 108

 7.4 MAGNETIC FIELD DATA 108

 7.5 INTERRUPT STATUS REGISTER 111

 7.6 POWER AND OPERATION MODES, SELF-TEST AND DATA OUTPUT RATE CONTROL REGISTERS 112

7.7 NUMBER OF REPETITIONS CONTROL REGISTERS 115

8. DIGITAL INTERFACES.....117

8.1 SERIAL PERIPHERAL INTERFACE (SPI) 118

8.2 INTER-INTEGRATED CIRCUIT (I²C) 122

8.2.1 SPI AND I²C ACCESS RESTRICTIONS 125

9. PIN-OUT AND CONNECTION DIAGRAM.....126

9.1 PIN-OUT 126

9.2 CONNECTION DIAGRAM 4-WIRE SPI 127

9.3 CONNECTION DIAGRAM 3-WIRE SPI 128

9.4 CONNECTION DIAGRAM I²C..... 129

10. PACKAGE130

10.1 OUTLINE DIMENSIONS..... 130

10.2 SENSING AXES ORIENTATION 131

10.3 ANDROID AXES ORIENTATION..... 132

10.4 LANDING PATTERN RECOMMENDATION 134

10.5 MARKING..... 135

10.5.1 MASS PRODUCTION DEVICES 135

10.5.2 ENGINEERING SAMPLES..... 135

10.6 SOLDERING GUIDELINES 136

10.7 HANDLING INSTRUCTIONS..... 137

10.8 TAPE AND REEL SPECIFICATION..... 138

10.8.1 TAPE AND REEL DIMENSIONS..... 138

10.8.2 ORIENTATION WITHIN THE REEL..... 138

10.9 ENVIRONMENTAL SAFETY 139

10.9.1 HALOGEN CONTENT 139

10.9.2 INTERNAL PACKAGE STRUCTURE 139

11. LEGAL DISCLAIMER.....140

11.1 ENGINEERING SAMPLES..... 140

11.2 PRODUCT USE 140

11.3 APPLICATION EXAMPLES AND HINTS 140

12. DOCUMENT HISTORY AND MODIFICATION141

1. Specification

If not stated otherwise, the given values are over lifetime and full performance temperature and voltage ranges, minimum/maximum values are $\pm 3\sigma$. The specifications are split into accelerometer part and magnetometer part of BMC156.

1.1 Compass electrical specification

Table 1: Compass electrical parameter specification

Compass Operating Conditions						
Parameter	Symbol	Condition	Min	Typ	Max	Unit
Supply Voltage Internal Domains	V_{DD}		1.62	2.4	3.6	V
Supply Voltage I/O Domain	V_{DDIO}		1.2	1.8	3.6	V
Voltage Input Low Level	$V_{IL,a}$	SPI & I ² C			$0.3V_{DDIO}$	-
Voltage Input High Level	$V_{IH,a}$	SPI & I ² C	$0.7V_{DDIO}$			-
Voltage Output Low Level	V_{OL}	$V_{DDIO} = 1.2V$ $I_{OL} = 3mA$, SPI & I ² C			$0.2V_{DDIO}$	-
Voltage Output High Level	V_{OH}	$V_{DDIO} = 1.62V$ $I_{OH} = 2mA$, SPI & I ² C	$0.8V_{DDIO}$			-

1.2 Accelerometer specification

Table 2: Accelerometer parameter specification

ACCELEROMETER Operating Conditions						
Parameter	Symbol	Condition	Min	Typ	Max	Unit
Acceleration Range	g_{FS2g}	Selectable via serial digital interface		± 2		g
	g_{FS4g}			± 4		g
	g_{FS8g}			± 8		g
	g_{FS16g}			± 16		g
Total Supply Current in Normal Mode	I_{DD}	$T_A=25^\circ\text{C}$, $bw = 1\text{kHz}$ $V_{DD} = V_{DDIO} = 2.4\text{V}$		130		μA
Total Supply Current in Low-Power Mode 1	I_{DDlp1}	$T_A=25^\circ\text{C}$, $bw = 1\text{kHz}$ $V_{DD} = V_{DDIO} = 2.4\text{V}$ sleep duration = 25ms		6.5		μA
Total Supply Current in Low-Power Mode 2	I_{DDlp2}	$T_A=25^\circ\text{C}$, $bw = 1\text{kHz}$ $V_{DD} = V_{DDIO} = 2.4\text{V}$ sleep duration = 25ms		66		μA
Total Supply Current in Deep Suspend Mode	$I_{DDsm,a}$	$T_A=25^\circ\text{C}$ $V_{DD} = V_{DDIO} = 2.4\text{V}$		1		μA
Total Supply Current in Suspend Mode	I_{DDsum}	$T_A=25^\circ\text{C}$ $V_{DD} = V_{DDIO} = 2.4\text{V}$		2.1		μA
Total Supply Current in Standby Mode	I_{DDsbm}	$T_A=25^\circ\text{C}$ $V_{DD} = V_{DDIO} = 2.4\text{V}$		62		μA
Wake-Up Time 1	$t_{w_up,a1}$	from Low-power Mode 1 or Suspend Mode or Deep Suspend Mode $bw = 1\text{kHz}$		1.3	1.8	ms
Wake-Up Time 2	$t_{w_up,a2}$	from Low-power Mode 2 or Stand-by Mode $bw = 1\text{kHz}$		1.0	1.2	μs
Start-Up Time	$t_{s_up,a}$	POR, $bw = 1\text{kHz}$			3	ms
Non-volatile memory (NVM) write-cycles	n_{NVM}				15	cycles

Operating Temperature	T_A	Same for accelerometer and magnetometer	-40		+85	°C
ACCELEROMETER OUTPUT SIGNAL						
Parameter	Symbol	Condition	Min	Typ	Max	Unit
Device Resolution	$D_{res,a}$	g_{FS2g}		0.98		mg
Sensitivity	S_{2g}	$g_{FS2g}, T_A=25^\circ C$		1024		LSB/g
	S_{4g}	$g_{FS4g}, T_A=25^\circ C$		512		LSB/g
	S_{8g}	$g_{FS8g}, T_A=25^\circ C$		256		LSB/g
	S_{16g}	$g_{FS16g}, T_A=25^\circ C$		128		LSB/g
Sensitivity Temperature Drift	TCS_a	g_{FS2g} , Nominal V_{DD} supplies		± 0.02		%/K
Zero-g Offset	Off	$g_{FS2g}, T_A=25^\circ C$, nominal V_{DD} supplies, over life-time		± 80		mg
Zero-g Offset Temperature Drift	TCO	g_{FS2g} , Nominal V_{DD} supplies		± 1		mg/K
Bandwidth	bw_8	2 nd order filter, bandwidth programmable		8		Hz
	bw_{16}			16		Hz
	bw_{31}			31		Hz
	bw_{63}			63		Hz
	bw_{125}			125		Hz
	bw_{250}			250		Hz
	bw_{500}			500		Hz
	bw_{1000}			1000		Hz
Nonlinearity	NL_a	best fit straight line, g_{FS2g}		± 0.5		%FS
Output Noise Density	$n_{rms,a}$	$g_{FS2g}, T_A=25^\circ C$ Nominal V_{DD} supplies Normal mode		150		$\mu g/\sqrt{Hz}$

Temperature Sensor Measurement Range	T_s		-40		85	°C
Temperature Sensor Slope	dT_s			0.5		K/LSB
Temperature Sensor Offset	OT_s			± 2		K

ACCELEROMETER MECHANICAL CHARACTERISTICS

Parameter	Symbol	Condition	Min	Typ	Max	Unit
Cross Axis Sensitivity	S_a	relative contribution between any two of the three axes		1		%
Alignment Error	$E_{A,a}$	relative to package outline		± 0.5		°

1.3 Magnetometer specification

Table 3: Magnetometer Parameter Specification

MAGNETOMETER Operating Conditions						
Parameter	Symbol	Condition	Min	Typ	Max	Unit
Magnetic field range	$B_{rg,xy}$	$T_A=25^{\circ}\text{C}^2$		± 1300		μT
	$B_{rg,z}$			± 2500		μT
Magnetometer heading accuracy ³	$A_{C\text{heading}}$	30 μT horizontal geomagnetic field component, $T_A=25^{\circ}\text{C}$			± 2.5	degree
System heading accuracy ⁴	$A_{S\text{heading}}$	30 μT horizontal geomagnetic field component, $T_A=25^{\circ}\text{C}$			± 3.0	degree
Supply Current in Active Mode (average) ⁵	$I_{DD,lp,m}$	Low power preset Nominal V_{DD} supplies $T_A=25^{\circ}\text{C}$, ODR=10Hz		170		μA
	$I_{DD,rg,m}$	Regular preset Nominal V_{DD} supplies $T_A=25^{\circ}\text{C}$, ODR=10Hz		0.5		mA
	$I_{DD,eh,m}$	Enhanced regular preset Nominal V_{DD} supplies $T_A=25^{\circ}\text{C}$, ODR=10Hz		0.8		mA
	$I_{DD,ha,m}$	High accuracy preset Nominal V_{DD} supplies $T_A=25^{\circ}\text{C}$, ODR=20Hz		4.9		mA
Supply Current in Suspend Mode	$I_{DDsm,m}$	Nominal V_{DD}/V_{DDIO} supplies, $T_A=25^{\circ}\text{C}$		1		μA
Peak supply current in Active Mode	$I_{DDpk,m}$	In measurement phase Nominal V_{DD} supplies $T_A=25^{\circ}\text{C}$		18		mA
Peak logic supply current in active mode	$I_{DDIOpk,m}$	Only during measurement phase Nominal V_{DDIO} supplies $T_A=25^{\circ}\text{C}$		210		μA

² Full linear measurement range considering sensor offsets.

³ The heading accuracy depends both on hardware and software. For detailed information of the software performance please contact Bosch Sensortec.

⁴ Heading accuracy of the tilt-compensated 6-axis eCompass system, assuming calibration with Bosch Sensortec eCompass software (only available for Android and Windows operating systems and requires the conclusion of a software licence agreement). Average value over various device orientations (typical device usage).

⁵ For details on magnetometer current consumption calculation refer to chapter 4.2.2 and 4.2.3.

POR time	$t_{w_up,m}$	from OFF to Suspend; time starts when VDD>1.5V and VDDIO>1.1V			1.0	ms
Start-Up Time	$t_{s_up,m}$	from Suspend to sleep			3.0	ms

MAGNETOMETER OUTPUT SIGNAL

Parameter	Symbol	Condition	Min	Typ	Max	Unit
Device Resolution	$D_{res,m}$	$T_A=25^\circ\text{C}$		0.3		μT
Gain error ⁶	$G_{err,m}$	After API temperature compensation $T_A=25^\circ\text{C}$ Nominal V_{DD} supplies		± 2		%
Sensitivity Temperature Drift	TCS_m	After API temperature compensation $-40^\circ\text{C} \leq T_A \leq +85^\circ\text{C}$ Nominal V_{DD} supplies		± 0.01		%/K
Zero-B offset	OFF_m	$T_A=25^\circ\text{C}$		± 40		μT
Zero-B offset	$OFF_{m,cal}$	After software calibration with Bosch Sensortec eCompass software ⁷ $-40^\circ\text{C} \leq T_A \leq +85^\circ\text{C}$		± 2		μT
Zero-B offset Temperature Drift	TCO_m	$-40^\circ\text{C} \leq T_A \leq +85^\circ\text{C}$ Nominal V_{DD} supplies		± 0.07		$\mu\text{T}/\text{K}$
ODR (data output rate), normal mode	odr_{lp}	Low power preset		10		Hz
	odr_{rg}	Regular preset		10		Hz
	odr_{eh}	Enhanced regular preset		10		Hz
	odr_{ha}	High accuracy preset		20		Hz
ODR (data output rate), forced mode	odr_{lp}	Low power preset	0		>300	Hz
	odr_{rg}	Regular preset	0		100	Hz
	odr_{eh}	Enhanced regular preset	0		60	Hz
	odr_{ha}	High accuracy preset	0		20	Hz
Full-scale Nonlinearity	$NL_{m,FS}$	best fit straight line			1	%FS
Output Noise	$n_{rms,lp,m,xy}$	Low power preset x, y-axis, $T_A=25^\circ\text{C}$ Nominal V_{DD} supplies		1.0		μT

⁶ Definition: $gain\ error = (measured\ field\ after\ API\ compensation) / (applied\ field) - 1$

⁷Magnetic zero-B offset assuming calibration with Bosch Sensortec eCompass software (only available for Android and Windows operating systems and requires the conclusion of a software licence agreement). Typical value after applying calibration movements containing various device orientations (typical device usage).

	$n_{rms,lp,m,z}$	Low power preset z-axis, $T_A=25^\circ\text{C}$ Nominal V_{DD} supplies		1.4		μT
	$n_{rms,rg,m}$	Regular preset $T_A=25^\circ\text{C}$ Nominal V_{DD} supplies		0.6		μT
	$n_{rms,eh,m}$	Enhanced regular preset $T_A=25^\circ\text{C}$ Nominal V_{DD} supplies		0.5		μT
	$n_{rms,ha,m}$	High accuracy preset $T_A=25^\circ\text{C}$ Nominal V_{DD} supplies		0.3		μT
Power Supply Rejection Rate	$PSRR_m$	$T_A=25^\circ\text{C}$ Nominal V_{DD} supplies		± 0.5		$\mu\text{T/V}$

2. Absolute maximum ratings

The absolute maximum ratings provided in Table 4 apply to both the accelerometer and magnetometer part of BMC156. At or above these maximum ratings operability is not given. The specification limits in Chapter 1 only apply under normal operating conditions.

Table 4: Absolute maximum ratings

Parameter	Condition	Min	Max	Unit
Voltage at Supply Pin	V _{DD} Pin	-0.3	4.0	V
	V _{DDIO} Pin	-0.3	4.0	V
Voltage at any Logic Pad	Non-Supply Pin	-0.3	V _{DDIO} + 0.3	V
Operating Temperature, T _A	Active operation	-40	+85	°C
Passive Storage Temp. Range	≤ 65% rel. H.	-50	+150	°C
None-volatile memory (NVM) Data Retention	T = 85°C, after 15 cycles	10		year
Mechanical Shock	Duration ≤ 200µs		10,000	g
	Duration ≤ 1.0ms		2,000	g
	Free fall onto hard surfaces		1.8	m
ESD	HBM, at any Pin		2	kV
	CDM		500	V
	MM		200	V
Magnetic field	Any direction		> 7	T

Note:

Stress above these limits may cause damage to the device. Exceeding the specified limits may affect the device reliability or cause malfunction.

3. Block diagram

Figure 1 shows the basic building blocks of the BMC156:

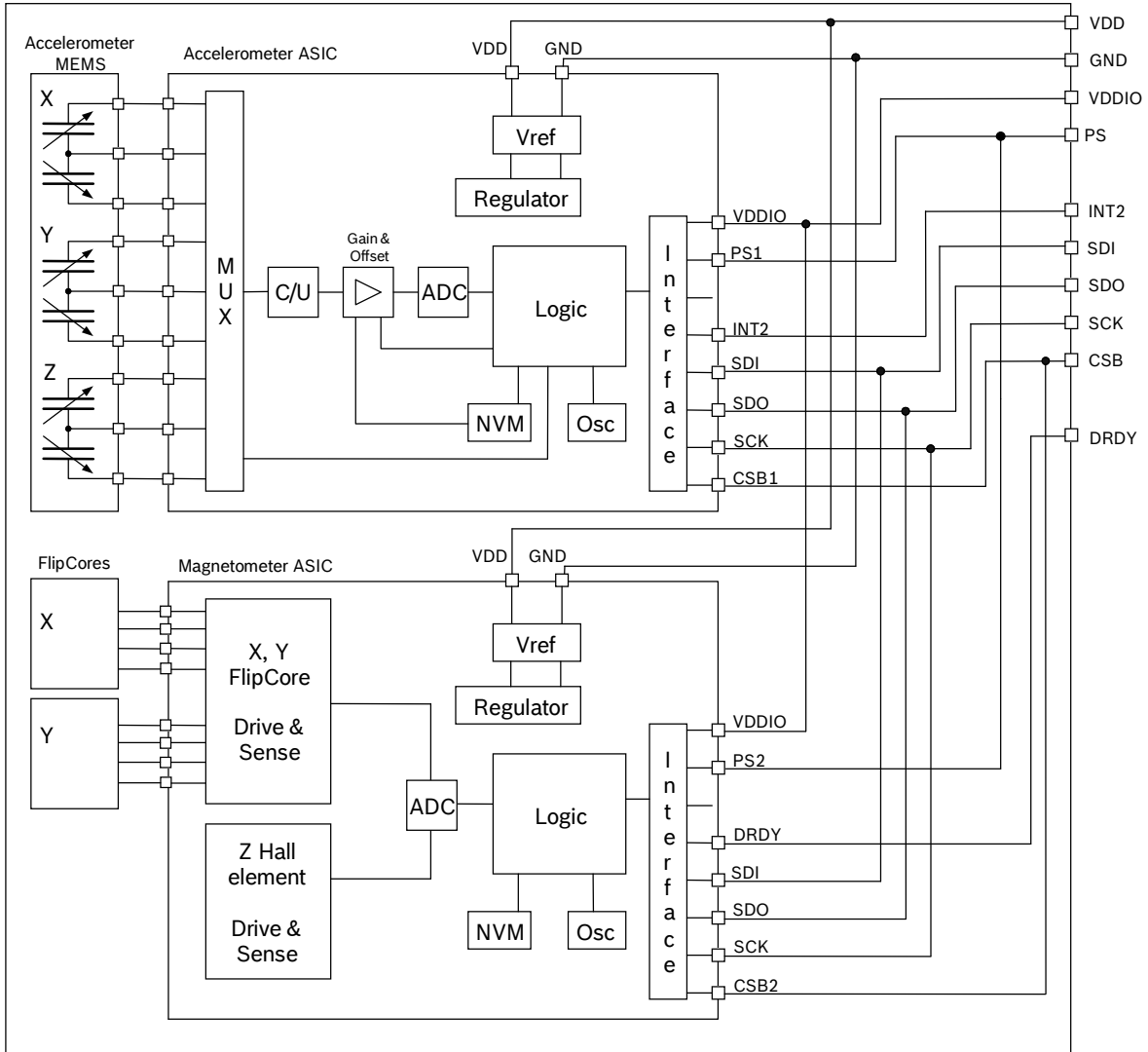

Figure 1: Block diagram of BMC156

4. Functional description

BMC156 is a SiP (system in package) integration of a triaxial accelerometer (Sensing element and ASIC) and a triaxial geomagnetic sensor (Sensing element and ASIC) in one package. The two ASICs act as two separate slave devices on the digital bus (with different I²C address in I²C mode), which allows an independent operation of accelerometer and magnetometer parts in order to fit into a wide range of usage scenarios.

4.1 Supply voltage and power management

The BMC156 has two distinct power supply pins which supply both the acceleration sensor part and the magnetometer sensor part:

- V_{DD} is the main power supply for all internal analog and digital functional blocks;
- V_{DDIO} is a separate power supply pin, used for the supply of the digital interface as well as the magnetic sensor's logic.

There are no limitations on the voltage levels of both pins relative to each other, as long as each of them lies within its operating range. Furthermore, the device can be completely switched off ($V_{DD} = 0V$) while keeping the V_{DDIO} supply within operating range or vice versa.

It is absolutely prohibited to keep any interface at a logical high level when V_{DDIO} is switched off. Such a configuration will permanently damage the device (i.e. if $V_{DDIO} = 0 \rightarrow [SDI \& SDO \& SCK \& CSB] \neq \text{high}$).

The device contains a power on reset (POR) generator for each of the sensor parts, accelerometer part and magnetometer part. It resets the logic part and the register values of the concerned ASIC after powering-on V_{DD} and V_{DDIO} . Please note, that all application specific settings which are not equal to the default settings (refer to register maps chapter 6.2 and 7.2), must be re-set to its designated values after POR.

There are no constraints on the sequence of switching on both supply voltages. In case the I²C interface is used, a direct electrical connection between V_{DDIO} supply and the PS pin is needed in order to ensure reliable protocol selection. For SPI interface mode the PS pin must be directly connected to GND.

4.2 Power modes

The BMC156 features separately configurable power modes for the accelerometer and the magnetometer part. The advantage is that different characteristics regarding optimum system power saving of the two sensor types are exploited, and that the accelerometer part may also be used alone in certain usage scenarios where no magnetic field data is required. In such an example, the magnetometer part is able to suspend and save power during the time in which it is not required.

In the following chapters, power modes for both accelerometer and magnetometer part are described.

4.2.1 Accelerometer power modes

The BMC156 accelerometer part has six different power modes (see Figure 2). Besides normal mode, which represents the fully operational state of the device, there are five energy saving modes: deep-suspend mode, suspend mode, standby mode, low-power mode 1 and low-power mode 2.

The possible transitions between the power modes are illustrated in Figure 2 :

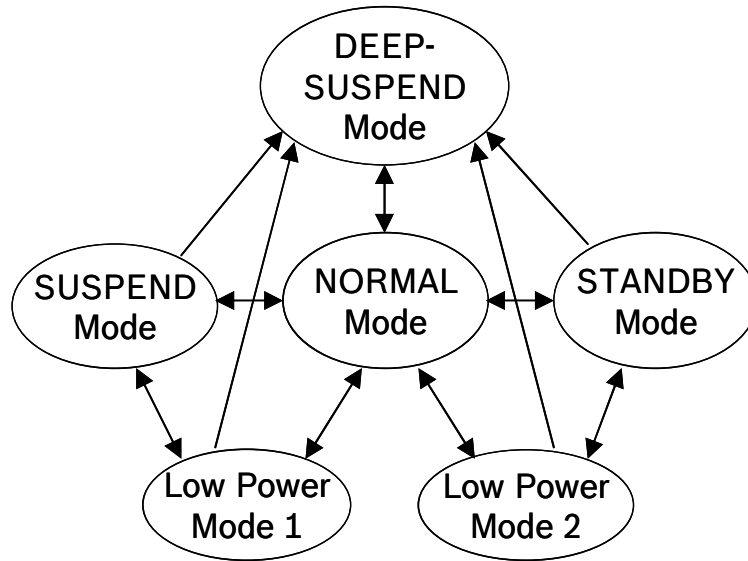

Figure 2: Power mode transition diagram

After power-up the accelerometer part of BMC156 is in normal mode so that this part is held powered-up and data acquisition is performed continuously.

In deep-suspend mode the device reaches the lowest possible power consumption. Only the interface section is kept alive. No data acquisition is performed and the content of the configuration registers is lost. Deep suspend mode is entered (left) by writing '1' ('0') to the (0x11) *deep_suspend* bit while (0x11) *suspend* bit is set to '0'. The I²C watchdog timer remains functional. The (0x11) *deep_suspend* bit, the (0x34) *spi3* bit, (0x34) *i2c_wdt_en* bit and the (0x34) *i2c_wdt_sel* bit are functional in deep-suspend mode. Equally the interrupt level and driver configuration registers (0x20) *int2_lvl*, and (0x20) *int2_od* are accessible. Still it is possible to enter normal mode by performing a softreset as described in chapter 4.8. Please note, that all application specific settings which are not equal to the default settings (refer to 6.2), must be re-set to its designated values after leaving deep-suspend mode.

In **suspend mode** the whole analog part is powered down. No data acquisition is performed. While in suspend mode the latest acceleration data and the content of all configuration registers are kept. Writing to and reading from registers is supported except from the (0x3E)

fifo_config_1, (0x30) fifo_config_0 and (0x3F) fifo_data register. It is possible to enter normal mode by performing a softreset as described in chapter.7.6.

Suspend mode is entered (left) by writing '1' ('0') to the (0x11) *suspend* bit after bit (0x12) *lowpower_mode* has been set to '0'. Although write access to registers is supported at the full interface clock speed (SCL or SCK), a waiting period must be inserted between two consecutive write cycles (please refer also to section 8.2.1).

In **standby mode** the analog part is powered down, while the digital part remains largely operational. No data acquisition is performed. Reading and writing registers is supported without any restrictions. The latest acceleration data and the content of all configuration registers are kept. Standby mode is entered (left) by writing '1' ('0') to the (0x11) *suspend* bit after bit (0x12) *lowpower_mode* has been set to '1'. It is also possible to enter normal mode by performing a softreset as described in chapter 7.6.

In **low-power mode 1**, the device is periodically switching between a sleep phase and a wake-up phase. The wake-up phase essentially corresponds to operation in normal mode with complete power-up of the circuitry. The sleep phase essentially corresponds to operation in suspend mode. Low-power mode is entered (left) by writing '1' ('0') to the (0x11) *lowpower_en* bit after bit (0x12) *lowpower_mode* has been set to '0'. Read access to registers is possible except from the (0x3F) *fifo_data* register. However, unless the register access is synchronised with the wake-up phase, the restrictions of the suspend mode apply.

Low-power mode 2 is very similar to low-power mode 1, but register access is possible at any time without restrictions. It consumes more power than low-power mode 1. In low-power mode 2 the device is periodically switching between a sleep phase and a wake-up phase. The wake-up phase essentially corresponds to operation in normal mode with complete power-up of the circuitry. The sleep phase essentially corresponds to operation in standby mode. Low-power mode is entered (left) by writing '1' ('0') to the (0x11) *lowpower_en* bit with bit (0x12) *lowpower_mode* set to '1'.

The timing behaviour of the low-power modes 1 and 2 depends on the setting of the (0x12) *sleeptimer_mode* bit. When (0x12) *sleeptimer_mode* is set to '0', the event-driven time-base mode (EDT) is selected. In EDT the duration of the wake-up phase depends on the number of samples required by the enabled interrupt engines. If an interrupt is detected, the device stays in the wake-up phase as long as the interrupt condition endures (non-latched interrupt), or until the latch time expires (temporary interrupt), or until the interrupt is reset (latched interrupt). If no interrupt is detected, the device enters the sleep phase immediately after the required number of acceleration samples have been taken and an active interface access cycle has ended. The EDT mode is recommended for power-critical applications which do not use the FIFO. Also, EDT mode is compatible with legacy BST sensors.

Figure 3 shows the timing diagram for low-power modes 1 and 2 when EDT is selected.

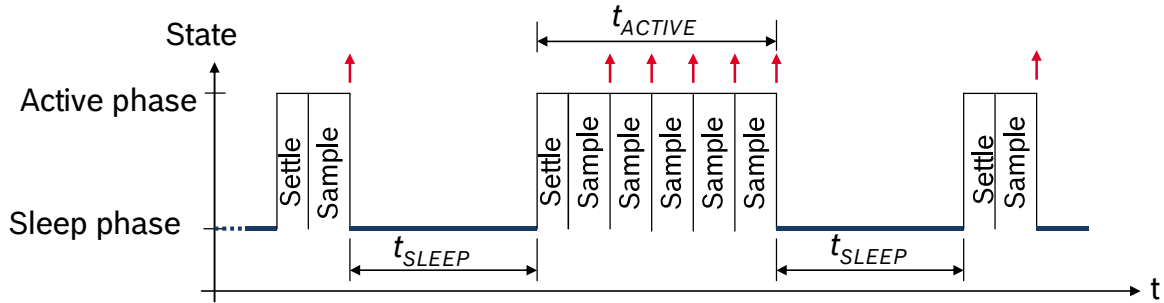

Figure 3: Timing Diagram for low-power mode 1/2, EDT

When $(0x12)$ *sleeptimer_mode* is set to '1', the equidistant-sampling mode (EST) is selected. The use of the EST mode is recommended when the FIFO is used since it ensures that equidistant samples are sampled into the FIFO regardless of whether the active phase is extended by active interrupt engines or interface activity. In EST mode the sleep time $t_{SLEEP,a}$ is defined as shown in Figure 4. The FIFO sampling time $t_{SAMPLE,a}$ is the sum of the sleep time $t_{SLEEP,a}$ and the sensor data sampling time $t_{SSMP,a}$. Since interrupt engines can extend the active phase to exceed the sleep time $t_{SLEEP,a}$, equidistant sampling is only guaranteed if the bandwidth has been chosen such that $1/(2 * bw) = n * t_{SLEEP,a}$ where n is an integer. If this condition is infringed, equidistant sampling is not possible. Once the sleep time has elapsed the device will store the next available sample in the FIFO. This set-up condition is not recommended as it may result in timing jitter.

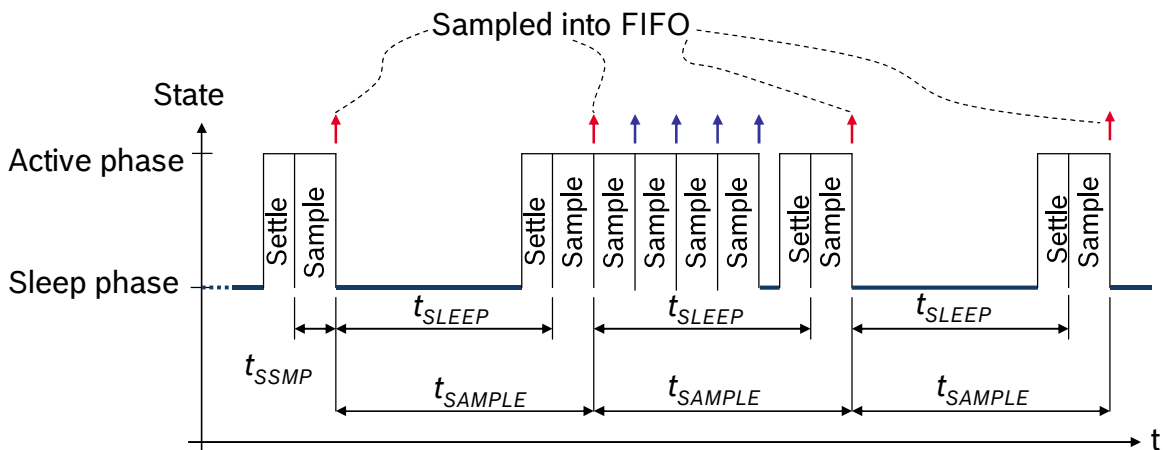

Figure 4: Timing Diagram for low-power mode 1/2, EST

The sleep time for lower-power mode 1 and 2 is set by the (0x11) *sleep_dur* bits as shown in the following table:

Table 5: Sleep phase duration settings

(0x11) <i>sleep_dur</i>	Sleep Phase Duration $t_{\text{SLEEP},a}$
0000b	0.5ms
0001b	0.5ms
0010b	0.5ms
0011b	0.5ms
0100b	0.5ms
0101b	0.5ms
0110b	1ms
0111b	2ms
1000b	4ms
1001b	6ms
1010b	10ms
1011b	25ms
1100b	50ms
1101b	100ms
1110b	500ms
1111b	1s

The current consumption of the BMC156 accelerometer part in low-power mode 1 (I_{DDlp1}) and low-power mode 2 (I_{DDlp2}) can be estimated with the following formulae:

$$I_{DDlp1,a} \approx \frac{t_{\text{sleep},a} \cdot I_{DDsum,a} + t_{\text{active},a} \cdot I_{DD,a}}{t_{\text{sleep},a} + t_{\text{active},a}}$$

$$I_{DDlp2,a} \approx \frac{t_{\text{sleep},a} \cdot I_{DDsbm,a} + t_{\text{active},a} \cdot I_{DD,a}}{t_{\text{sleep},a} + t_{\text{active},a}}$$

When estimating the length of the wake-up phase t_{active} , the corresponding typical wake-up time, $t_{w,up1}$ or $t_{w,up2}$ and t_{ut} (given in table 5) have to be considered:

If bandwidth is ≥ 31.25 Hz:

$$t_{\text{active}} = t_{ut} + t_{w,up1} - 0.9 \text{ ms (or } t_{\text{active}} = t_{ut} + t_{w,up2} - 0.9 \text{ ms)}$$

else:

$$t_{\text{active}} = 4 t_{ut} + t_{w,up1} - 0.9 \text{ ms (or } t_{\text{active}} = 4 t_{ut} + t_{w,up2} - 0.9 \text{ ms)}$$

During the wake-up phase all analog modules are held powered-up, while during the sleep phase most analog modules are powered down. Consequently, a wake-up time of at least $t_{w,up1}$ ($t_{w,up2}$) is needed to settle the analog modules so that reliable acceleration data are generated.

4.2.2 Magnetometer power modes

The BMC156 magnetometer part features configurable power modes. The four power modes of the BMC156 magnetometer are described in the following chapters.

Power off mode

In Power off mode, V_{DD} and/or V_{DDIO} are unpowered. The magnetometer part does not operate in this mode. When only one of V_{DD} or V_{DDIO} is supplied, the magnetic sensor will still be in Power off mode. Power on reset is performed after both V_{DD} and V_{DDIO} have raised above their detection thresholds.

Suspend mode

Suspend mode is the default power mode of BMC156 magnetometer part after the chip is powered. When V_{DD} and V_{DDIO} are turned on the POR (power on reset) circuits operate and the device's registers are initialized. After POR becomes inactive, a start up sequence is executed. In this sequence NVM content is downloaded to shadow registers located in the device core. After the start up sequence the device is put in the Suspend mode. In this mode only registers which store power control bit information and SPI 3 wire enable can be accessed by the user. In this mode only registers supplied directly by V_{DDIO} which store I²C slave device address, power control bit information and some others can be accessed by the user. No other registers can be accessed in Suspend mode. All registers lose their content, except the control register (0x4B). In particular, in this mode a Chip ID read (register 0x40) returns "0x00" (I²C) or high-Z (SPI).

Sleep mode

The user puts device from suspend into Sleep mode by setting the Power bit to “1”, or from active modes (normal or forced) by setting OpMode bits to “11”. In this state the user has full access to the device registers. In particular, the Chip ID can be read. Setting the power control bit to “0” (register *0x4B bit0*) will bring the device back into Suspend mode. From the Sleep mode the user can put the device back into Suspend mode or into Active mode.

Active mode

The device can switch into Active mode from Sleep mode by setting OpMode bits (register *0x4C*). In active mode the magnetic field measurements are performed. In active mode, all registers are accessible.

In active mode, two operation modes can be distinguished:

- Normal mode: selected channels are periodically measured according to settings set in user registers. After measurements are completed, output data is put into data registers and the device waits for the next measurement period, which is set by programmed output data rate (ODR). From normal mode, the user can return to sleep mode by setting OpMode to “11” or by performing a soft reset (see chapter 7.6). Suspend mode can be entered by setting power control bit to “0”.
- Forced mode (single measurement): When set by the host, the selected channels are measured according to settings programmed in user registers. After measurements are completed, output data is put into data registers, OpMode register value returns to “11” and the device returns to sleep mode. The forced mode is useful to achieve synchronized operation between host microcontroller and BMC156. Also, different data output rates from the ones selectable in normal mode can be achieved using forced mode.

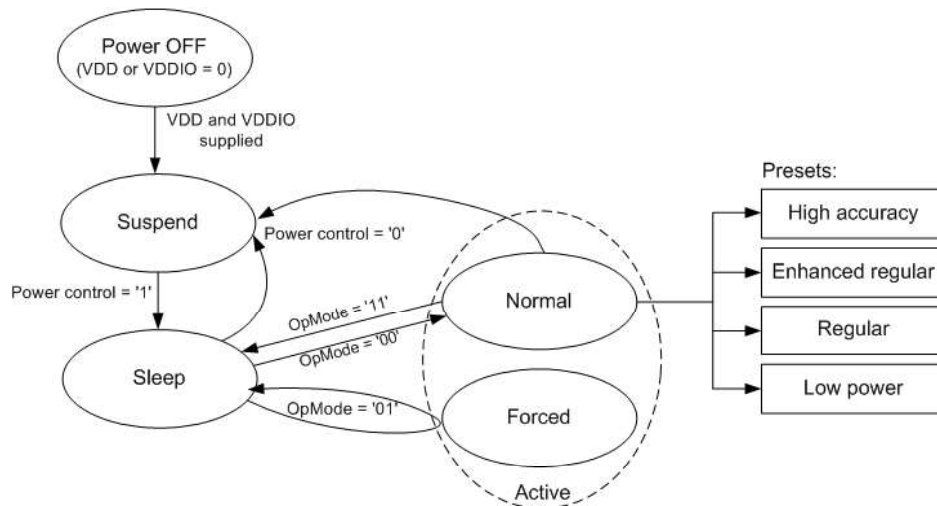

Figure 5: Magnetometer power mode transition diagram

In Active Mode and normal operation, in principle any desired balance between output noise and active time (hence power consumption) can be adjusted by the repetition settings for x/y-axis and z-axis and the output data rate ODR. The average power consumption depends on the ratio of high current phase time (during data acquisition) and low current phase time (between

data acquisitions). Hence, the more repetitions are acquired to generate one magnetic field data point, the longer the active time ratio in one sample phase, and the higher the average current. Thanks to longer internal averaging, the noise level of the output data reduces with increasing number of repetitions.

By using forced mode, it is possible to trigger new measurements at any rate. The user can therefore trigger measurements in a shorter interval than it takes for a measurement cycle to complete. If a measurement cycle is not allowed to complete, the resulting data will not be written into the data registers. To prevent this, the manually triggered measurement intervals must not be shorter than the active measurement time which is a function of the selected number of repetitions. The maximum selectable read-out frequency in forced mode can be calculated as follows:

$$f_{\max,ODR} \approx \frac{1}{145\mu s \times nXY + 500\mu s \times nZ + 980\mu s}$$

Hereby nXY is the number of repetitions on X/Y-axis (not the register value) and nZ the number of repetitions on Z-axis (not the register value) (see description of XY_REP and Z_REP registers in chapter 7).

Although the repetition numbers for X/Y and Z axis and the ODR can be adjusted independently and in a wide range, there are four recommended presets (High accuracy preset, Enhanced regular preset, Regular preset, Low power preset) which reflect the most common usage scenarios, i.e. required output accuracy at a given current consumption, of the BMC156 magnetometer part.

The four presets consist of the below register configurations, which are automatically set by the BMC156 API or driver provided by Bosch Sensortec when a preset is selected. Table 6 shows the recommended presets and the resulting magnetic field output noise and magnetometer part current consumption:

Table 6: Magnetometer presets in Active operation and normal mode:

Preset	X/Y rep	Z rep	ODR	ODR _{max} (forced mode)	RMS Noise x/y/z	Average current consumption
Low power preset	3	3	10 Hz	>300 Hz	1.0/1.0/1.4 μT	170 μA
Regular preset	9	15	10 Hz	100 Hz	0.6/0.6/0.6 μT	0.5 mA
Enhanced regular preset	15	27	10 Hz	60 Hz	0.5/0.5/0.5 μT	0.8 mA
High accuracy preset	47	83	20 Hz	20 Hz	0.3/0.3/0.3 μT	4.9 mA

4.2.3 BMC156 overall power consumption

Below, Table 7 shows the overall current consumption of BMC156 (sum of accelerometer and magnetometer part) in typical scenarios such as a tilt-compensated electronic compass application.

Table 7: BMC156 overall current consumption in typical usage scenarios:

Compass preset	Acc. Active / sleep interval	Acc. BW / ODR	Mag. Avg. current	Acc. avg. current	Total average current
Low power preset	8 / 50 ms	62.5 / 17 Hz	170 μ A	20 μ A	190 μ A
Regular preset	16 / 50 ms	31 / 15 Hz	0.5 mA	35 μ A	0.54 mA
Enhanced regular preset	16 / 50 ms	31 / 15 Hz	0.8 mA	35 μ A	0.84 mA
High accuracy preset	16 / 25 ms	31 / 24 Hz	4.9 mA	55 μ A	5.0 mA

4.3 Sensor data

4.3.1 Acceleration data

The width of acceleration data is 12 bits given in two's complement representation. The 12 bits for each axis are split into an MSB upper part (one byte containing bits 11 to 4) and an LSB lower part (one byte containing bits 3 to 0 of acceleration and a (0x02, 0x04, 0x06) *new_data* flag). Reading the acceleration data registers shall always start with the LSB part. In order to ensure the integrity of the acceleration data, the content of an MSB register is locked by reading the corresponding LSB register (shadowing procedure). When shadowing is enabled, the MSB must always be read in order to remove the data lock. The shadowing procedure can be disabled (enabled) by writing '1' ('0') to the bit *shadow_dis*. With shadowing disabled, the content of both MSB and LSB registers is updated by a new value immediately. Unused bits of the LSB registers may have any value and should be ignored. The (0x02, 0x04, 0x06) *new_data* flag of each LSB register is set if the data registers have been updated. The flag is reset if either the corresponding MSB or LSB part is read.

Two different streams of acceleration data are available, unfiltered and filtered. The unfiltered data is sampled with 2kHz. The sampling rate of the filtered data depends on the selected filter bandwidth and is always twice the selected bandwidth ($BW = ODR/2$). Which kind of data is stored in the acceleration data registers depends on bit (0x13) *data_high_bw*. If (0x13) *data_high_bw* is '0' ('1'), then filtered (unfiltered) data is stored in the registers. Both data streams are offset-compensated.

The bandwidth of filtered acceleration data is determined by setting the (0x10) *bw* bit as followed:

Table 8: Bandwidth configuration

bw	Bandwidth	Update Time t_{ut}
00xxx	*)	-
01000	7.81Hz	64ms
01001	15.63Hz	32ms
01010	31.25Hz	16ms
01011	62.5Hz	8ms
01100	125Hz	4ms
01101	250Hz	2ms
01110	500Hz	1ms
01111	1000Hz	0.5ms
1xxxx	*)	-

***) Note:**

Settings 00xxx result in a bandwidth of 7.81 Hz; settings 1xxxx result in a bandwidth of 1000 Hz. It is recommended to actively use the range from '01000b' to '01111b' only in order to be compatible with future products.

The BMC156's accelerometer part supports four different acceleration measurement ranges. A measurement range is selected by setting the (0x0F) range bits as follows:

Table 9: Range selection

Range	Acceleration measurement range	Resolution
0011	±2g	0.98mg/LSB
0101	±4g	1.95mg/LSB
1000	±8g	3.91mg/LSB
1100	±16g	7.81mg/LSB
others	reserved	-

4.3.2 Temperature sensor

The width of temperature data is 8 bits given in two's complement representation. Temperature values are available in the (0x08) temp register.

The slope of the temperature sensor is 0.5K/LSB, its center temperature is 23°C [(0x08) temp = 0x00].

4.3.3 Magnetic field data

The representation of magnetic field data is different between X/Y-axis and Z-axis. The width of X- and Y-axis magnetic field data is 13 bits each and stored in two's complement.

DATA_X_LSB (0x42) contains 5-bit LSB part [4:0] of the 13 bit output data of the X-channel.

DATA_X_MSB (0x43) contains 8-bit MSB part [12:5] of the 13 bit output data of the X-channel.

DATA_Y_LSB (0x44) contains 5-bit LSB part [4:0] of the 13 bit output data of the Y-channel.

DATA_Y_MSB (0x45) contains 8-bit MSB part [12:5] of the 13 bit output data of the Y-channel.

The width of the Z-axis magnetic field data is 15 bit word stored in two's complement.

DATA_Z_LSB (0x46) contains 7-bit LSB part [6:0] of the 15 bit output data of the Z-channel.

DATA_Z_MSB (0x47) contains 8-bit MSB part [14:7] of the 15 bit output data of the Z-channel.

For all axes, temperature compensation on the host is used to get ideally matching sensitivity over the full temperature range. The temperature compensation is based on a resistance measurement of the hall sensor plate. The resistance value is represented by a 14 bit unsigned output word.

RHALL_LSB (0x48) contains 6-bit LSB part [5:0] of the 14 bit output data of the RHALL-channel.

RHALL_MSB (0x49) contains 8-bit MSB part [13:6] of the 14 bit output data of the RHALL-channel.

All signed register values are in two's complement representation. Bits which are marked "reserved" can have different values or can in some cases not be read at all (read will return 0x00 in I²C mode and high-Z in SPI mode).

Data register readout and shadowing is implemented as follows:

After all enabled axes have been measured, complete data packages consisting of DATA_X, DATA_Y, DATA_Z and RHALL are updated at once in the data registers. This way, it is prevented that a following axis is updated while the first axis is still being read (axis mix-up) or that MSB part of an axis is updated while LSB part is being read.

While reading from any data register, data register update is blocked. Instead, incoming new data is written into shadow registers which will be written to data registers after the previous read sequence is completed (i.e. upon stop condition in I²C mode, or CSB going high in SPI mode, respectively). Hence, it is recommended to read out all data at once (0x42 to 0x49 or 0x4A if status bits are also required) with a burst read.

Single bytes or axes can be read out, while in this case it is not assured that adjacent registers are not updated during readout sequence.

The “Data ready status” bit (register 0x48 bit0) is set “1” when the data registers have been updated but the data was not yet read out over digital interface. Data ready is cleared (set “0”) directly after completed read out of any of the data registers and subsequent stop condition (I²C) or lifting of CSB (SPI).

In addition, when enabled the “Data overrun” bit (register 0x4A bit7) turns “1” whenever data registers are updated internally, but the old data was not yet read out over digital interface (i.e. data ready bit was still high). The “Data overrun” bit is cleared when the interrupt status register 0x4A is read out. This function needs to be enabled separately by setting the “Data overrun En” bit (register 0x4D bit7).

Note:

Please also see chapter 7 for detailed register descriptions.

4.3.4 Magnetic field data temperature compensation

The raw register values DATA_X, DATA_Y, DATA_Z and RHALL are read out from the host processor using the BMC156 API/driver which is provided by Bosch Sensortec. The API/driver performs an off-chip temperature compensation and outputs x/y/z magnetic field data in 16 LSB/ μ T to the upper application layer:

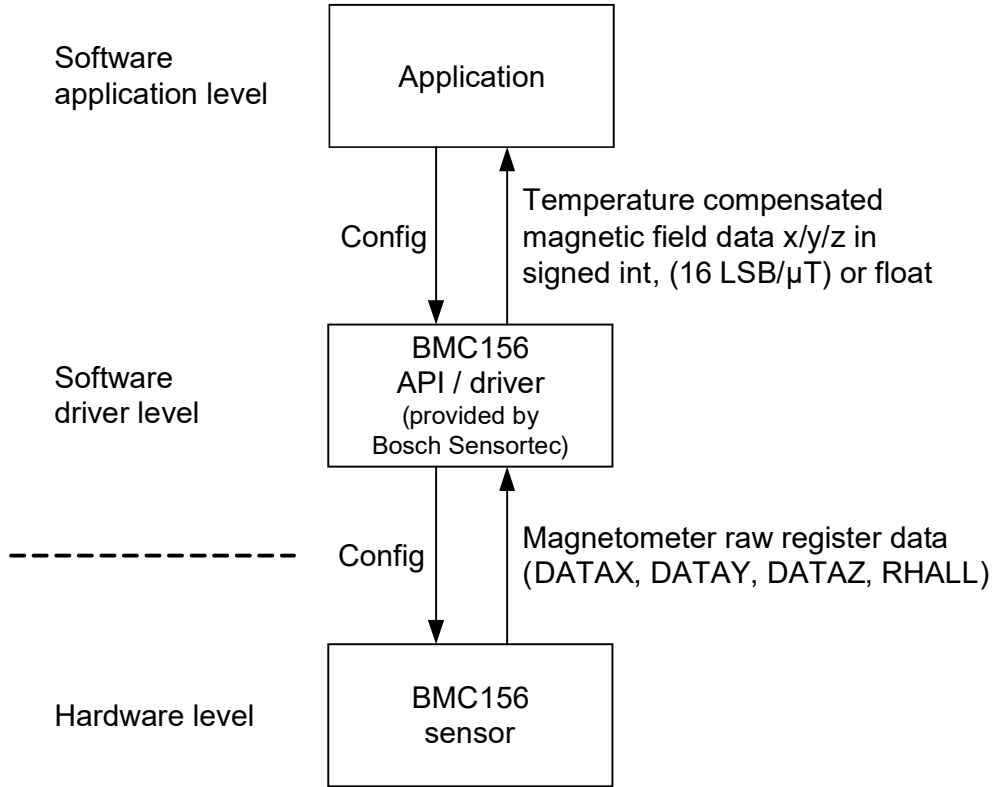

Figure 6: Calculation flow of magnetic field data from raw BMC156 register data

The API/driver performs all calculations using highly optimized fixed-point C-code arithmetic. For platforms that do not support C code, a floating-point formula is available as well.

4.4 Self-test

4.4.1 Accelerometer self-test

This feature permits to check the BMC156's accelerometer part functionality by applying electrostatic forces to the sensor core instead of external accelerations. By actually deflecting the seismic mass, the entire signal path of the sensor can be tested. Activating the self-test results in a static offset of the acceleration data; any external acceleration or gravitational force applied to the sensor during active self-test will be observed in the output as a superposition of both acceleration and self-test signal.

Before the self-test is enabled the g-range should be set to 8 g. The self-test is activated individually for each axis by writing the proper value to the (0x32) *self_test_axis* bits ('01b' for x-axis, '10b' for y-axis, '11b' for z-axis, '00b' to deactivate self-test). It is possible to control the direction of the deflection through bit (0x32) *self_test_sign*. The excitation occurs in negative (positive) direction if (0x32) *self_test_sign* = '0b' ('1b'). The amplitude of the deflection has to be set high by writing (0x32) *self_test_amp*='1b'. After the self-test is enabled, the user should wait 50ms before interpreting the acceleration data.

In order to ensure a proper interpretation of the self-test signal it is recommended to perform the self-test for both (positive and negative) directions and then to calculate the difference of the resulting acceleration values. Table 10 shows the minimum differences for each axis. The actually measured signal differences can be significantly larger.

Table 10: Self-test difference values

	x-axis signal	y-axis signal	z-axis signal
resulting minimum difference signal	800 mg	800 mg	400 mg

It is recommended to perform a reset of the device after a self-test has been performed. If the reset cannot be performed, the following sequence must be kept to prevent unwanted interrupt generation: disable interrupts, change parameters of interrupts, wait for at least 50ms, enable desired interrupts.

4.4.2 Magnetometer self-test

BMC156 supports two self-tests modes for the magnetometer part: Normal self-test and advanced self-test.

Normal self test

During normal self-test, the following verifications are performed:

- FlipCore signal path is verified by generating signals on-chip. These are processed through the signal path and the measurement result is compared to known thresholds.
- FlipCore (X and Y) bondwires to ASIC are checked for connectivity
- FlipCore (X and Y) bondwires and MEMS are checked for shorts
- Hall sensor connectivity is checked for open and shorted connections
- Hall sensor signal path and hall sensor element offset are checked for overflow.

To perform a self test, the sensor must first be put into sleep mode (OpMode = "11"). Self-test mode is then entered by setting the bit "Self test" (register *0x4C bit0*) to "1". After performing self test, this bit is set back to "0". When self-test is successful, the corresponding self-test result bits are set to "1" ("X-Self-Test" register *0x42 bit0*, "Y-Self-Test" register *0x44 bit0*, "Z-Self-Test" register *0x46 bit0*). If self-test fails for an axis, the corresponding result bit returns "0".

Advanced self test

Advanced self test performs a verification of the Z channel signal path functionality and sensitivity. An on-chip coil wound around the hall sensor can be driven in both directions with a calibrated current to generate a positive or negative field of around 100 μT .

Advanced self test is an option that is active in parallel to the other operation modes. The only difference is that during the active measurement phase, the coil current is enabled. The recommended usage of advanced self test is the following:

1. Set sleep mode
2. Disable X, Y axis
3. Set Z repetitions to desired level
4. Enable positive advanced self test current
5. Set forced mode, readout Z and R channel after measurement is finished
6. Enable negative advanced self test current
7. Set forced mode, readout Z and R channel after measurement is finished
8. Disable advanced self test current (this must be done manually)
9. Calculate difference between the two compensated field values. This difference should be around 200 μT with some margins.
10. Perform a soft reset of manually restore desired settings

Please refer to the corresponding application note for the exact thresholds to evaluate advanced self-test.

Below table describes how the advanced self-test is controlled:

Table 11: Magnetometer advanced self-test control

(0x4C) Adv.ST <1:0>	Configuration
00b	Normal operation (no self-test), default
01b	Reserved, do not use
10b	Negative on-chip magnetic field generation
11b	Positive on-chip magnetic field generation

The BMC156 API/driver provided by Bosch Sensortec provides a comfortable way to perform both self-tests and to directly obtain the result without further calculations. It is recommended to use this as a reference.

4.5 Accelerometer offset compensation

Offsets in measured acceleration signals can have several causes but they are always unwanted and disturbing in many cases. Therefore, the accelerometer part of BMC156 offers an advanced set of four digital offset compensation methods which are closely matched to each other. These are slow, fast, and manual compensation, and inline calibration.

The compensation is performed with unfiltered data, and is then applied to both, unfiltered and filtered data. If necessary the result of this computation is saturated to prevent any overflow errors (the smallest or biggest possible value is set, depending on the sign). However, the registers used to read and write compensation values have only a width of 8 bits.

An overview of the offset compensation principle is given in Figure 7:

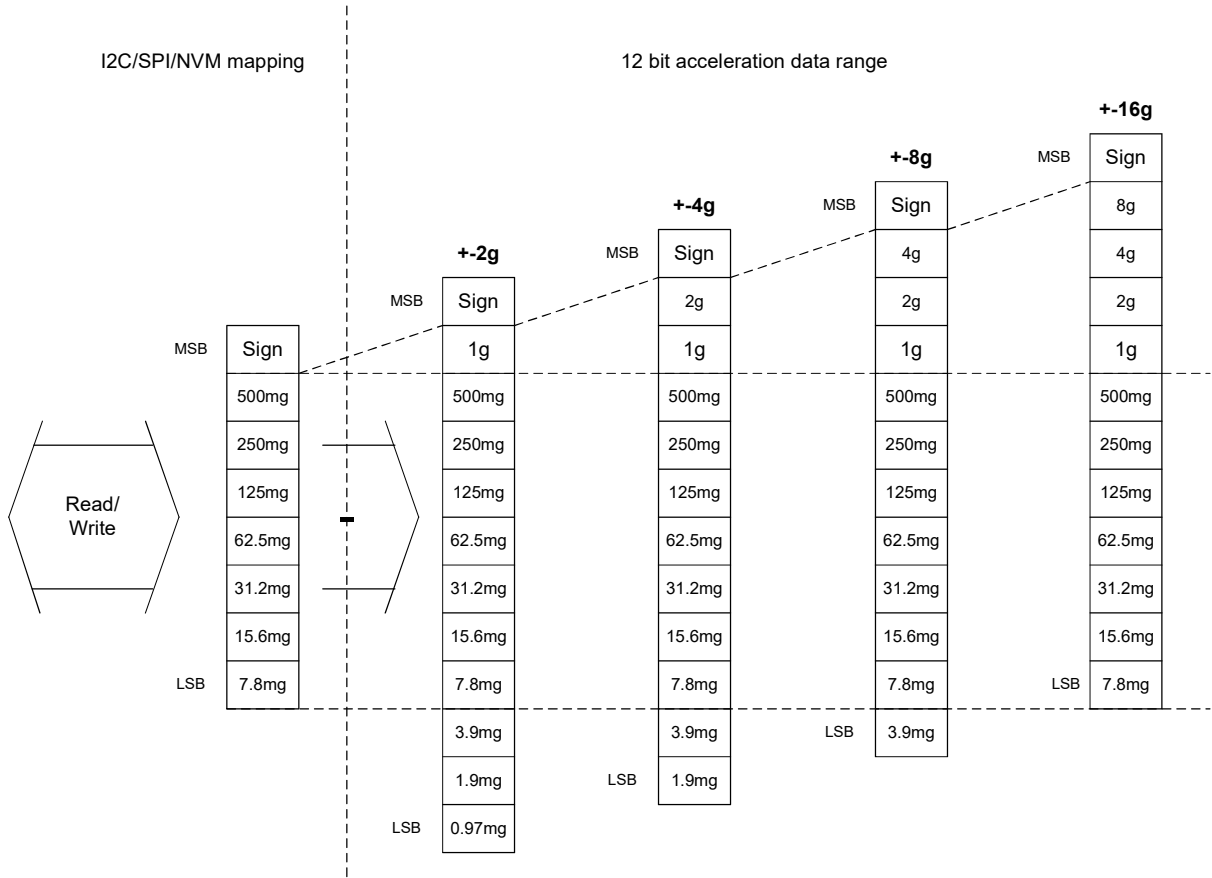

Figure 7: Principle of offset compensation

The public offset compensation registers (*0x38*) *offset_x*, (*0x39*) *offset_y*, (*0x3A*) *offset_z* are images of the corresponding registers in the NVM. With each image update (see section 4.6 for details) the contents of the NVM registers are written to the public registers. The public register can be over-written by the user at any time. After changing the contents of the public registers by either an image update or manually, all 8bit values are extended to 12bit values for internal computation. In the opposite direction, if an internally computed value changes it is converted to an 8bit value and stored in the public register.

Depending on the selected g-range the conversion from 12bit to 8bit values can result in a loss of accuracy of one to several LSB. This is shown in Figure 7.

In case an internally computed compensation value is too small or too large to fit into the corresponding register, it is saturated in order to prevent an overflow error.

By writing '1' to the (*0x36*) *offset_reset* bit, all offset compensation registers are reset to zero.

4.5.1 Slow compensation

Slow compensation is based on a 1st order high-pass filter, which continuously drives the average value of the output data stream of each axis to zero. The bandwidth of the high-pass filter is configured with bit (0x37) *cut_off* according to .

Table 12: Compensation period settings

(0x37) <i>cut_off</i>	high-pass filter bandwidth	Example <i>bw = 500 Hz</i>
0b	$\frac{1Hz \times bw *}{1000 Hz}$	$\frac{1Hz \times 500 Hz}{1000 Hz} = 0.5 Hz$
1b	$\frac{10Hz \times bw *}{1000 Hz}$	$\frac{10Hz \times 500 Hz}{1000 Hz} = 5 Hz$

**bw*: please insert selected decimal data bandwidth value [Hz] from table 8

The slow compensation can be enabled (disabled) for each axis independently by setting the bits (0x36) *hp_x_en*, *hp_y_en*, *hp_z_en* to '1' ('0'), respectively.

Slow compensation should not be used in combination with low-power mode. In low-power mode the conditions (availability of necessary data) for proper function of slow compensation are not fulfilled.

4.5.2 Fast compensation

Fast compensation is a one-shot process by which the compensation value is set in such a way that when added to the raw acceleration, the resulting acceleration value of each axis approaches the target value. This is best suited for “end-of-line trimming” with the customer’s device positioned in a well-defined orientation. For fast compensation the g-range has to be switched to 2g.

The algorithm in detail: An average of 16 consecutive acceleration values is computed and the difference between target value and computed value is written to (0x38, 0x39, 0x3A) *offset_filt_x/y/z*. The public registers (0x38, 0x39, 0x3A) *offset_filt_x/y/z* are updated with the contents of the internal registers (using saturation if necessary) and can be read by the user.

Fast compensation is triggered for each axis individually by setting the (0x36) *cal_trigger* bits as shown in Table 13:

Table 13: Fast compensation axis selection

(0x36) <i>cal_trigger</i>	Selected Axis
00b	none
01b	x
10b	y
11b	z

Register (0x36) *cal_trigger* is a write-only register. Once triggered, the status of the fast correction process is reflected in the status bit (0x36) *cal_rdy*. Bit (0x36) *cal_rdy* is '0' while the correction is in progress. Otherwise it is '1'. Bit (0x36) *cal_rdy* is '0' when (0x36) *cal_trigger* is not '00'.

For the fast offset compensation, the compensation target can be chosen by setting the bits (0x37) *offset_target_x*, (0x37) *offset_target_y*, and (0x37) *offset_target_z* according to Table 14:

Table 14: Offset target settings

(0x37) offset_target_x/y/z	Target value
00b	0g
01b	+1g
10b	-1g
11b	0g

Fast compensation should not be used in combination with any of the low-power modes. In low-power mode the conditions (availability of necessary data) for proper function of fast compensation are not fulfilled.

4.5.3 Manual compensation

The contents of the public compensation registers (0x38, 0x39, 0x3A) *offset_filt_x/y/z* can be set manually via the digital interface. It is recommended to write into these registers directly after a new data interrupt has occurred in order not to disturb running offset computations.

Writing to the offset compensation registers is not allowed while the fast compensation procedure is running.

4.5.4 Inline calibration

For certain applications, it is often desirable to calibrate the offset once and to store the compensation values permanently. This can be achieved by using one of the aforementioned offset compensation methods to determine the proper compensation values and then storing these values permanently in the NVM. See chapter 4.6.1 for details of the storing procedure.

Each time the device is reset, the compensation values are loaded from the non-volatile memory into the image registers and used for offset compensation until they are possibly overwritten using one of the other compensation methods.

4.6 Non-volatile memory

4.6.1 Accelerometer non-volatile memory

The memory of the accelerometer part of BMC156 consists of three different kinds of registers: hard-wired, volatile, and non-volatile. Part of it can be both read and written by the user. Access to non-volatile memory is only possible through (volatile) image registers.

Altogether, there are eight registers (octets) with NVM backup which are accessible by the user. The addresses of the image registers range from $0x38$ to $0x3C$. While the addresses up to $0x3A$ are used for offset compensation (see section 4.5), addresses $0x3B$ and $0x3C$ are general purpose registers not linked to any sensor-specific functionality.

The content of the NVM is loaded to the image registers after a reset (either POR or soft reset) or after a user request which is performed by writing '1' to the write-only bit ($0x33$) *nvm_load*. As long as the image update is in progress, bit ($0x33$) *nvm_rdy* is '0', otherwise it is '1'.

The image registers can be read and written like any other register.

Writing to the NVM is a three-step procedure:

1. Write the new contents to the image registers.
2. Write '1' to bit ($0x33$) *nvm_prog_mode* in order to unlock the NVM.
3. Write '1' to bit ($0x33$) *nvm_prog_trig* and keep '1' in bit ($0x33$) *nvm_prog_mode* in order to trigger the write process.

Writing to the NVM always renews the entire NVM contents. It is possible to check the write status by reading bit ($0x33$) *nvm_rdy*. While ($0x33$) *nvm_rdy* = '0', the write process is still in progress; if ($0x33$) *nvm_rdy* = '1', then writing is completed. As long as the write process is ongoing, no change of power mode and image registers is allowed. Also, the NVM write cycle must not be initiated while image registers are updated, in low-power mode, and in suspend mode.

Please note that the number of permitted NVM write-cycles is limited as specified in Table 2. The number of remaining write-cycles can be obtained by reading bits ($0x33$) *nvm_remain*.

4.6.2 Magnetometer non-volatile memory

Some of the memory of the BMC156 magnetometer is non-volatile memory (NVM). This NVM is pre-programmed in Bosch Sensortec fabrication line and cannot be modified afterwards. It contains trimming data which are required for sensor operation and sensor data compensation, thus it is read out by the BMC156 API/driver during initialization.

4.7 Accelerometer interrupt controller

The accelerometer part of BMC156 is equipped with eight programmable interrupt engines. Each interrupt can be independently enabled and configured. If the trigger condition of an enabled interrupt is fulfilled, the corresponding status bit is set to '1' and the selected interrupt pin is activated. There is one interrupt pin for the accelerometer part, INT2; interrupts can be freely mapped to this pin. The state of a specific interrupt pin is derived from a logic 'or' combination of all interrupts mapped to it.

The interrupt status registers are updated when a new data word is written into the acceleration data registers. If an interrupt is disabled, all active status bits associated with it are immediately reset.

4.7.1 General features

An interrupt is cleared depending on the selected interrupt mode, which is common to all interrupts. There are three different interrupt modes: non-latched, latched, and temporary. The mode is selected by the (0x21) *latch_int* bits according to Table 15.

Table 15 : Accelerometer interrupt mode selection

(0x21) <i>atch_int</i>	Interrupt mode
0000b	non-latched
0001b	temporary, 250ms
0010b	temporary, 500ms
0011b	temporary, 1s
0100b	temporary, 2s
0101b	temporary, 4s
0110b	temporary, 8s
0111b	latched
1000b	non-latched
1001b	temporary, 250µs
1010b	temporary, 500µs
1011b	temporary, 1ms
1100b	temporary, 12.5ms
1101b	temporary, 25ms
1110b	temporary, 50ms
1111b	latched

An interrupt is generated if its activation condition is met. It cannot be cleared as long as the activation condition is fulfilled. In the non-latched mode the interrupt status bit and the interrupt pin (INT2) are cleared as soon as the activation condition is no more valid. Exceptions to this behavior are the new data, orientation, and flat interrupts, which are automatically reset after a fixed time.

In latched mode an asserted interrupt status and the selected pin are cleared by writing '1' to bit (0x21) *reset_int*. If the activation condition still holds when it is cleared, the interrupt status is asserted again with the next change of the acceleration registers.

In the temporary mode an asserted interrupt and selected pin are cleared after a defined period of time. The behavior of the different interrupt modes is shown graphically in Figure 8. The timings in this mode are subject to the same tolerances as the bandwidths (see Table 2).

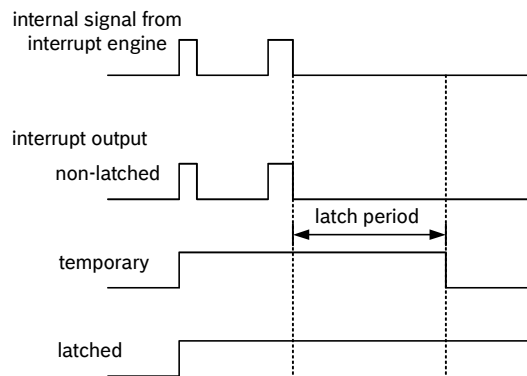

Figure 8: Interrupt modes

Several interrupt engines can use either unfiltered or filtered acceleration data as their input. For these interrupts, the source can be selected with the bits in register (0x1E). These are (0x1E) *int_src_data*, (0x1E) *int_src_tap*, (0x1E) *int_src_slo_no_mot*, (0x1E) *int_src_slope*, (0x1E) *int_src_high*, and (0x1E) *int_src_low*. Setting the respective bits to '0' ('1') selects filtered (unfiltered) data as input. The orientation recognition and flat detection interrupt always use filtered input data.

It is strongly recommended to set interrupt parameters prior to enabling the interrupt. Changing parameters of an already enabled interrupt may cause unwanted interrupt generation and generation of a false interrupt history. A safe way to change parameters of an enabled interrupt is to keep the following sequence: disable the desired interrupt, change parameters, wait for at least 10ms, and then re-enable the desired interrupt.

4.7.2 Mapping to physical interrupt pins (inttype to INT Pin#)

Registers (0x1A) to (0x1B) are dedicated to mapping of interrupts to the interrupt pin "INT2". Setting (0x1B) *int2_"inttype"* to '1' ('0') maps (unmaps) "inttype" to pin "INT2".

Note:

"inttype" to be replaced with the precise notation, given in the memory map in chapter 5.

Example: For flat interrupt (*int2_flat*): Setting (0x1B) *int2_flat* to '1' maps *int2_flat* to pin "INT2".

4.7.3 Electrical behavior (INT pin# to open-drive or push-pull)

The interrupt pin can be configured to show the desired electrical behavior. The 'active' level of the interrupt pin is determined by the (0x20) *int2_lvl* bits.

If (0x20) *int2_lvl* = '1' ('0'), then pin "INT2" is active '1' ('0'). The characteristic of the output driver of the interrupt pin may be configured with bit (0x20) *int2_od*. By setting bit (0x20) *int2_od* to '1', the output driver shows open-drive characteristic, by setting the configuration bit to '0', the output driver shows push-pull characteristic. When open-drive characteristic is selected in the design, external pull-up or pull-down resistor should be applied according the *int_lvl* configuration.

4.7.4 New data interrupt

This interrupt serves for synchronous reading of acceleration data. It is generated after storing a new value of z-axis acceleration data in the data register. The interrupt is cleared automatically when the next data acquisition cycle starts. The interrupt status is '0' for at least 50µs.

The interrupt mode of the new data interrupt is fixed to non-latched.

It is enabled (disabled) by writing '1' ('0') to bit (0x17) *data_en*. The interrupt status is stored in bit (0x0A) *data_int*.

Due to the settling time of the filter, the first interrupt after wake-up from suspend or standby mode will take longer than the update time

4.7.5 Slope / any-motion detection

Slope / any-motion detection uses the slope between successive acceleration signals to detect changes in motion. An interrupt is generated when the slope (absolute value of acceleration difference) exceeds a preset threshold. It is cleared as soon as the slope falls below the threshold. The principle is made clear in Figure 9.

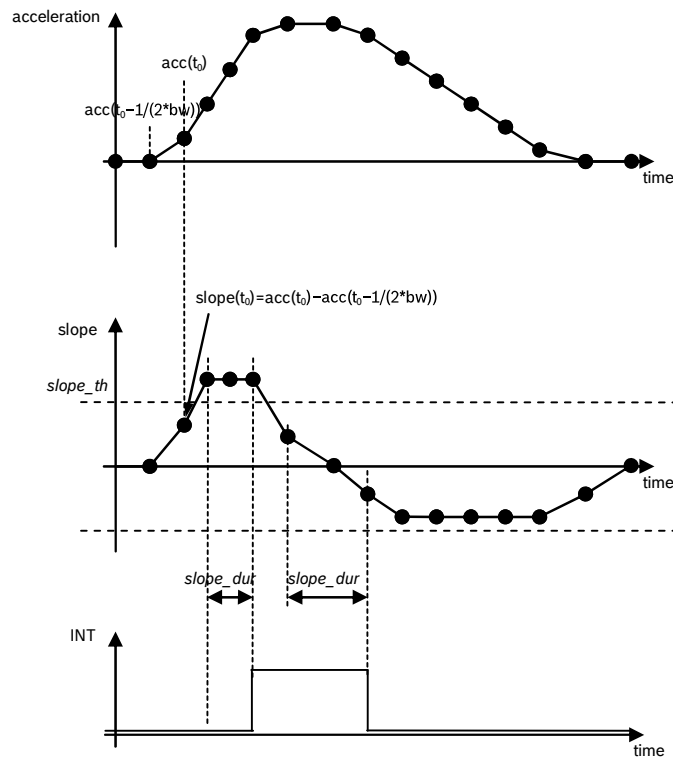

Figure 9: Principle of any-motion detection

The threshold is defined through register (0x28) *slope_th*. In terms of scaling 1 LSB of (0x28) *slope_th* corresponds to 3.91 mg in 2g-range (7.81 mg in 4g-range, 15.6 mg in 8g-range and 31.3 mg in 16g-range). Therefore the maximum value is 996 mg in 2g-range (1.99g in 4g-range, 3.98g in 8g-range and 7.97g in 16g-range).

The time difference between the successive acceleration signals depends on the selected bandwidth and equates to $1/(2 \cdot \text{bandwidth})$ ($t = 1/(2 \cdot \text{bw})$). In order to suppress false triggers, the interrupt is only generated (cleared) if a certain number N of consecutive slope data points is larger (smaller) than the slope threshold given by (0x28) *slope_th*. This number is set by the (0x27) *slope_dur* bits. It is $N = (0x27) \text{ slope_dur} + 1$ for (0x27).

Example: (0x27) *slope_dur* = 00b, ..., 11b = 1decimal, ..., 4decimal.

4.7.5.1 Enabling (disabling) for each axis

Any-motion detection can be enabled (disabled) for each axis separately by writing '1' ('0') to bits (0x16) *slope_en_x*, (0x16) *slope_en_y*, (0x16) *slope_en_z*. The criteria for any-motion detection are fulfilled and the slope interrupt is generated if the slope of any of the enabled axes exceeds the threshold (0x28) *slope_th* for [(0x27) *slope_dur* +1] consecutive times. As soon as the slopes of all enabled axes fall or stay below this threshold for [(0x27) *slope_dur* +1] consecutive times the interrupt is cleared unless interrupt signal is latched.

4.7.5.2 Axis and sign information of slope / any motion interrupt

The interrupt status is stored in bit (0x09) *slope_int*. The any-motion interrupt supplies additional information about the detected slope. The axis which triggered the interrupt is given by that one of bits (0x0B) *slope_first_x*, (0x0B) *slope_first_y*, (0x0B) *slope_first_z* that contains a value of '1'. The sign of the triggering slope is held in bit (0x0B) *slope_sign* until the interrupt is retriggered. If (0x0B) *slope_sign* = '0' ('1'), the sign is positive (negative).

4.7.6 Tap sensing

Tap sensing has a functional similarity with a common laptop touch-pad or clicking keys of a computer mouse. A tap event is detected if a pre-defined slope of the acceleration of at least one axis is exceeded. Two different tap events are distinguished: A 'single tap' is a single event within a certain time, followed by a certain quiet time. A 'double tap' consists of a first such event followed by a second event within a defined time frame.

Single tap interrupt is enabled (disabled) by writing "1" ("0") to bit (0x16) *s_tap_en*. Double tap interrupt is enabled (disabled) by writing "1" ("0") to bit (0x16) *d_tap_en*. While temporary latching is used do not simultaneously enable single tap interrupt and double tap interrupt.

The status of the single tap interrupt is stored in bit (0x09) *s_tap_int*, the status of the double tap interrupt is stored in bit (0x09) *d_tap_int*.

The slope threshold for detecting a tap event is set by bits (0x2B) *tap_th*. The meaning of (0x2B) *tap_th* depends on the range setting. 1 LSB of (0x2B) *tap_th* corresponds to a slope of 62.5mg in 2g-range, 125mg in 4g-range, 250mg in 8g-range, and 500mg in 16g-range.

In Figure 10 the meaning of the different timing parameters is visualized:

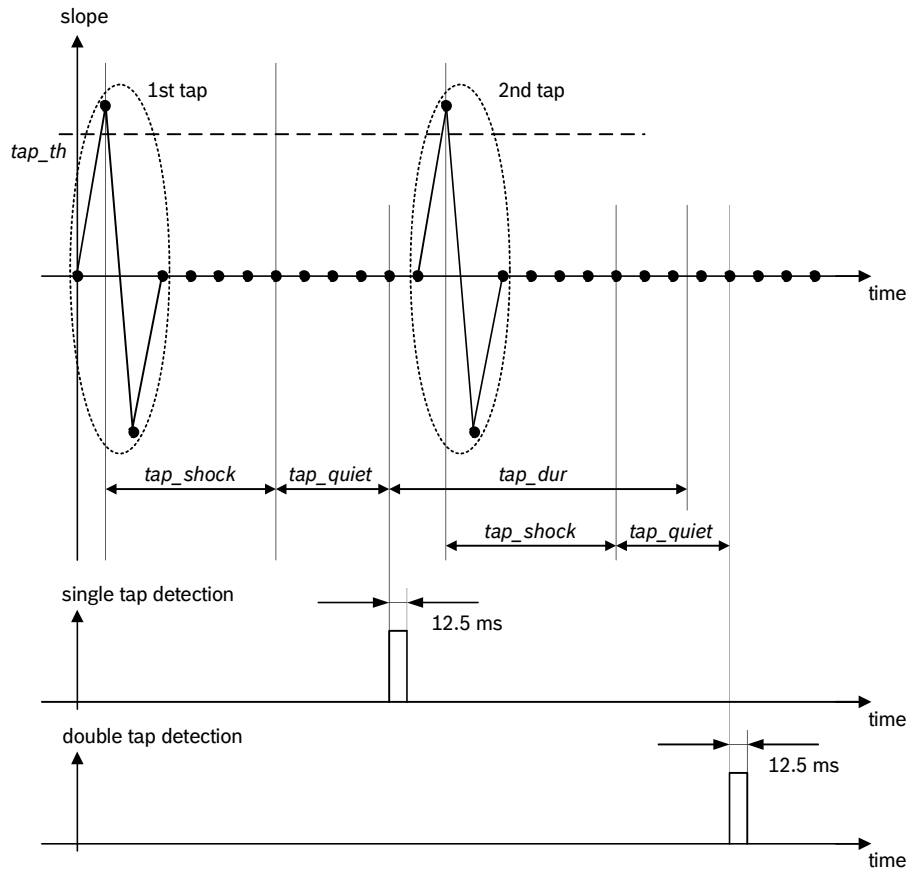

Figure 10: Timing of tap detection

The parameters $(0x2A)$ *tap_shock* and $(0x2A)$ *tap_quiet* apply to both single tap and double tap detection, while $(0x2A)$ *tap_dur* applies to double tap detection only. Within the duration of $(0x2A)$ *tap_shock* any slope exceeding $(0x2B)$ *tap_th* after the first event is ignored. Contrary to this, within the duration of $(0x2A)$ *tap_quiet* no slope exceeding $(0x2B)$ *tap_th* must occur, otherwise the first event will be cancelled.

4.7.6.1 Single tap detection

A single tap is detected and the single tap interrupt is generated after the combined durations of $(0x2A)$ *tap_shock* and $(0x2A)$ *tap_quiet*, if the corresponding slope conditions are fulfilled. The interrupt is cleared after a delay of 12.5 ms. Do not map single-tap to INT pin if you do not want to use it.

4.7.6.2 Double tap detection

A double tap interrupt is generated if an event fulfilling the conditions for a single tap occurs within the set duration in $(0x2A)$ *tap_dur* after the completion of the first tap event. The interrupt is automatically cleared after a delay of 12.5 ms.

4.7.6.3 Selecting the timing of tap detection

For each of parameters $(0x2A)$ *tap_shock* and $(0x2A)$ *tap_quiet* two values are selectable. By writing '0' ('1') to bit $(0x2A)$ *tap_shock* the duration of $(0x2A)$ *tap_shock* is set to 50 ms (75 ms). By writing '0' ('1') to bit $(0x2A)$ *tap_quiet* the duration of $(0x2A)$ *tap_quiet* is set to 30 ms (20 ms).

The length of $(0x2A)$ *tap_dur* can be selected by setting the $(0x2A)$ *tap_dur* bits according to Table 16:

Table 16: Selection of *tap_dur*

$(0x2A)$ <i>tap_dur</i>	length of <i>tap_dur</i>
000b	50 ms
001b	100 ms
010b	150 ms
011b	200 ms
100b	250 ms
101b	375 ms
110b	500 ms
111b	700 ms

4.7.6.4 Axis and sign information of tap sensing

The sign of the slope of the first tap which triggered the interrupt is stored in bit $(0x0B)$ *tap_sign* ('0' means positive sign, '1' means negative sign). The value of this bit persists after clearing the interrupt.

The axis which triggered the interrupt is indicated by bits $(0x0B)$ *tap_first_x*, $(0x0B)$ *tap_first_y*, and $(0x0B)$ *tap_first_z*.

The bit corresponding to the triggering axis contains a '1' while the other bits hold a '0'. These bits are cleared together with clearing the interrupt status.

4.7.6.5 Tap sensing in low power mode

In low-power mode, a limited number of samples is processed after wake-up to decide whether an interrupt condition is fulfilled. The number of samples is selected by bits $(0x2B)$ *tap_samp* according to Table 17.

Table 17: Meaning of $(0x2B)$ *tap_samp*

$(0x2B)$ <i>tap_samp</i>	Number of Samples
00b	2
01b	4
10b	8
11b	16

4.7.7 Orientation recognition

The orientation recognition feature informs on an orientation change of the sensor with respect to the gravitational field vector 'g'. The measured acceleration vector components with respect to the gravitational field are defined as shown in Figure 11.

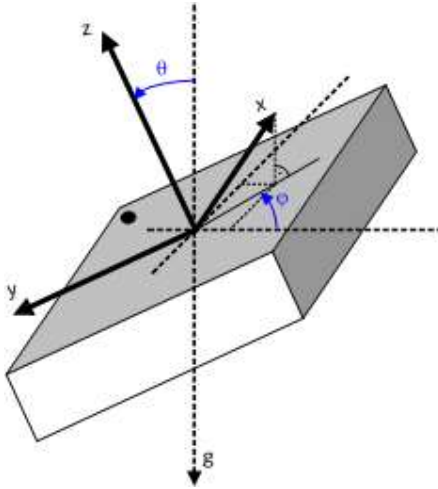

Figure 11: Definition of vector components

Therefore, the magnitudes of the acceleration vectors are calculated as follows:

$$\begin{aligned} \text{acc_x} &= 1g \times \sin\theta \times \cos\varphi \\ \text{acc_y} &= -1g \times \sin\theta \times \sin\varphi \\ \text{acc_z} &= 1g \times \cos\theta \\ \text{acc_y/acc_x} &= -\tan\varphi \end{aligned}$$

Depending on the magnitudes of the acceleration vectors the orientation of the device in the space is determined and stored in the three (0x0C) *orient* bits. These bits may not be reset in the sleep phase of low-power mode. There are three orientation calculation modes with different thresholds for switching between different orientations: symmetrical, high-asymmetrical, and low-asymmetrical. The mode is selected by setting the (0x2C) *orient_mode* bits as given in Table 18.

Table 18: Orientation mode settings

(0x2C) <i>orient_mode</i>	Orientation Mode
00b	symmetrical
01b	high-asymmetrical
10b	low-asymmetrical
11b	symmetrical

For each orientation mode the (0x0C) *orient* bits have a different meaning as shown in Table 19 to Table 21:

Table 19: Meaning of the (0x0C) *orient* bits in symmetrical mode

(0x0C) orient	Name	Angle	Condition
x00	portrait upright	$315^\circ < \varphi < 45^\circ$	$ acc_y < acc_x - 'hyst'$ and $acc_x - 'hyst' \geq 0$
x01	portrait upside down	$135^\circ < \varphi < 225^\circ$	$ acc_y < acc_x - 'hyst'$ and $acc_x + 'hyst' < 0$
x10	landscape left	$45^\circ < \varphi < 135^\circ$	$ acc_y \geq acc_x + 'hyst'$ and $acc_y < 0$
x11	landscape right	$225^\circ < \varphi < 315^\circ$	$ acc_y \geq acc_x + 'hyst'$ and $acc_y \geq 0$

Table 20: Meaning of the (0x0C) *orient* bits in high-asymmetrical mode

(0x0C) orient	Name	Angle	Condition
x00	portrait upright	$297^\circ < \varphi < 63^\circ$	$ acc_y < 2 \cdot acc_x - 'hyst'$ and $acc_x - 'hyst' \geq 0$
x01	portrait upside down	$117^\circ < \varphi < 243^\circ$	$ acc_y < 2 \cdot acc_x - 'hyst'$ and $acc_x + 'hyst' < 0$
x10	landscape left	$63^\circ < \varphi < 117^\circ$	$ acc_y \geq 2 \cdot acc_x + 'hyst'$ and $acc_y < 0$
x11	landscape right	$243^\circ < \varphi < 297^\circ$	$ acc_y \geq 2 \cdot acc_x + 'hyst'$ and $acc_y \geq 0$

Table 21: Meaning of the (0x0C) *orient* bits in low-asymmetrical mode

(0x0C) orient	Name	Angle	Condition
x00	portrait upright	$333^\circ < \varphi < 27^\circ$	$ acc_y < 0.5 \cdot acc_x - 'hyst'$ and $acc_x - 'hyst' \geq 0$
x01	portrait upside down	$153^\circ < \varphi < 207^\circ$	$ acc_y < 0.5 \cdot acc_x - 'hyst'$ and $acc_x + 'hyst' < 0$
x10	landscape left	$27^\circ < \varphi < 153^\circ$	$ acc_y \geq 0.5 \cdot acc_x + 'hyst'$ and $acc_y < 0$
x11	landscape right	$207^\circ < \varphi < 333^\circ$	$ acc_y \geq 0.5 \cdot acc_x + 'hyst'$ and $acc_y \geq 0$

In the preceding tables, the parameter 'hyst' stands for a hysteresis, which can be selected by setting the $(0x2C)$ *orient_hyst* bits. 1 LSB of $(0x2C)$ *orient_hyst* always corresponds to 62.5 mg, in any g-range (i.e. increment is independent from g-range setting). It is important to note that by using a hysteresis $\neq 0$ the actual switching angles become different from the angles given in the tables since there is an overlap between the different orientations.

The most significant bit of the $(0x0C)$ *orient* bits (which is displayed as an 'x' in the above given tables) contains information about the direction of the z-axis. It is set to '0' ('1') if $acc_z \geq 0$ ($acc_z < 0$).

Figure 12 shows the typical switching conditions between the four different orientations for the symmetrical mode i.e. without hysteresis:

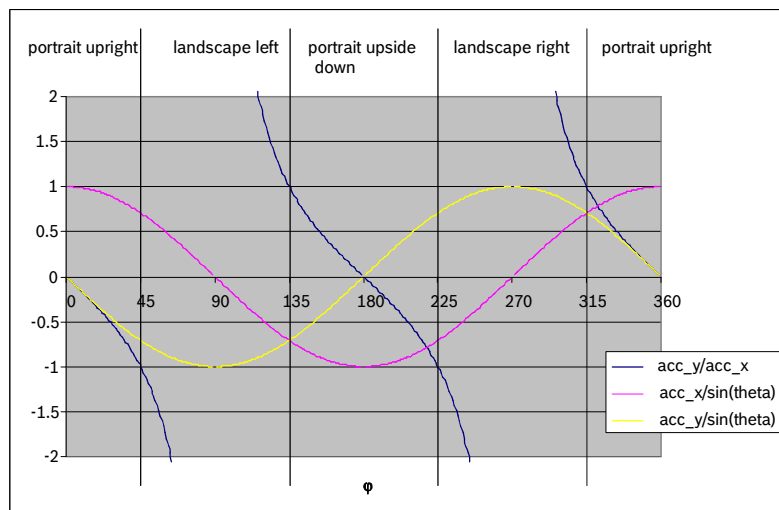

Figure 12: Typical orientation switching conditions w/o hysteresis

The orientation interrupt is enabled (disabled) by writing '1' ('0') to bit $(0x16)$ *orient_en*. The interrupt is generated if the value of $(0x0C)$ *orient* has changed. It is automatically cleared after one stable period of the $(0x0C)$ *orient* value. The interrupt status is stored in the $(0x09)$ *orient_int* bit. The register $(0x0C)$ *orient* always reflects the current orientation of the device, irrespective of which interrupt mode has been selected. Bit $(0x0C)$ *orient*<2> reflects the device orientation with respect to the z-axis. The bits $(0x0C)$ *orient*<1:0> reflect the device orientation in the x-y-plane. The conventions associated with register $(0x0C)$ *orient* are detailed in chapter 5.

4.7.7.1 Orientation blocking

The change of the (0x0C) *orient* value and – as a consequence – the generation of the interrupt can be blocked according to conditions selected by setting the value of the (0x2C) *orient_blocking* bits as described by Table 22.

Table 22: Blocking conditions for orientation recognition

(0x2C) <i>orient_blocking</i>	Conditions
00b	no blocking
01b	theta blocking or acceleration in any axis > 1.5g
10b	theta blocking or acceleration slope in any axis > 0.2 g or acceleration in any axis > 1.5g
11b	theta blocking or acceleration slope in any axis > 0.4 g or acceleration in any axis > 1.5g and value of orient is not stable for at least 100 ms

The theta blocking is defined by the following inequality:

$$|\tan \theta| < \frac{\sqrt{\text{blocking_theta}}}{8}$$

The parameter *blocking_theta* of the above given equation stands for the contents of the (0x2D) *orient_theta* bits. It is possible to define a blocking angle between 0° and 44.8°. The internal blocking algorithm saturates the acceleration values before further processing. As a consequence, the blocking angles are strictly valid only for a device at rest; they can be different if the device is moved.

Example:

To get a maximum blocking angle of 19° the parameter *blocking_theta* is determined in the following way: $(8 * \tan(19^\circ))^2 = 7.588$, therefore, *blocking_value* = 8dec = 001000b has to be chosen.

In order to avoid unwanted generation of the orientation interrupt in a nearly flat position (z ~ 0, sign change due to small movements or noise), a hysteresis of 0.2 g is implemented for the z-axis, i. e. a after a sign change the interrupt is only generated after |z| > 0.2 g.

4.7.7.2 Up-Down Interrupt Suppression Flag

Per default an orientation interrupt is triggered when any of the bits in register (0x0C) *orient* changes state. The BMA255 can be configured to trigger orientation interrupts only when the device position changes in the x-y-plane while orientation changes with respect to the z-axis are ignored. A change of the orientation of the z-axis, and hence a state change of bit (0x0C) *orient*<2> is ignored (considered) when bit (0x2D) *orient_ud_en* is set to '0' ('1').

4.7.8 Flat detection

The flat detection feature gives information about the orientation of the devices' z-axis relative to the g-vector, i. e. it recognizes whether the device is in a flat position or not.

The flat angle Θ is adjustable by $(0x2E)$ *flat_theta* from 0° to 44.8°. The flat angle can be set according to following formula:

$$\Theta = \text{atan}\left(\frac{1}{8}\sqrt{\text{flat_theta}}\right)$$

A hysteresis of the flat detection can be enabled by $(0x2F)$ *flat_hy* bits. In this case the flat position is set if the angle drops below following threshold:

$$\Theta_{\text{hyst,tl}} = \text{atan}\left(\frac{1}{8}\sqrt{\text{flat_theta} \cdot \left(1 - \frac{\text{flat_hy}}{1024}\right) - \frac{\text{flat_hy}}{16}}\right)$$

The flat position is reset if the angle exceeds the following threshold:

$$\Theta_{\text{hyst,ul}} = \text{atan}\left(\frac{1}{8}\sqrt{\text{flat_theta} \cdot \left(1 + \frac{\text{flat_hy}}{1024}\right) + \frac{\text{flat_hy}}{16}}\right)$$

The flat interrupt is enabled (disabled) by writing '1' ('0') to bit $(0x16)$ *flat_en*. The flat value is stored in the $(0x0C)$ *flat* bit if the interrupt is enabled. This value is '1' if the device is in the flat position, it is '0' otherwise. The flat interrupt is generated if the flat value has changed and the new value is stable for at least the time given by the $(0x2F)$ *flat_hold_time* bits. A flat interrupt may be also generated if the flat interrupt is enabled. The actual status of the interrupt is stored in the $(0x09)$ *flat_int* bit. The flat orientation of the sensor can always be determined from reading the $(0x0C)$ *flat* bit after interrupt generation. If unlatched interrupt mode is used, the $(0x09)$ *flat_int* value and hence the interrupt is automatically cleared after one sample period. If temporary or latched interrupt mode is used, the $(0x09)$ *flat_int* value is kept fixed until the latch time expires or the interrupt is reset.

The meaning of the $(0x2F)$ *flat_hold_time* bits can be seen from Table 23.

Table 23: Meaning of flat_hold_time

(0x2F) flat_hold_time	Time
00b	0
01b	512 ms
10b	1024 ms
11b	2048 ms

4.7.9 Low-g interrupt

This interrupt is based on the comparison of acceleration data against a low-g threshold, which is most useful for free-fall detection.

The interrupt is enabled (disabled) by writing “1” (“0”) to the (0x17) *low_en* bit. There are two modes available, ‘single’ mode and ‘sum’ mode. In ‘single’ mode, the acceleration of each axis is compared with the threshold; in ‘sum’ mode, the sum of absolute values of all accelerations $|acc_x| + |acc_y| + |acc_z|$ is compared with the threshold. The mode is selected by the contents of the (0x24) *low_mode* bit: “0” means ‘single’ mode, “1” means ‘sum’ mode.

The low-g threshold is set through the (0x23) *low_th* register. 1 LSB of (0x23) *low_th* always corresponds to an acceleration of 7.81 mg (i.e. increment is independent from g-range setting).

A hysteresis can be selected by setting the (0x24) *low_hy* bits. 1 LSB of (0x24) *low_hy* always corresponds to an acceleration difference of 125 mg in any g-range (as well, increment is independent from g-range setting).

The low-g interrupt is generated if the absolute values of the acceleration of all axes (‘and’ relation, in case of single mode) or their sum (in case of sum mode) are lower than the threshold for at least the time defined by the (0x22) *low_dur* register. The interrupt is reset if the absolute value of the acceleration of at least one axis (‘or’ relation, in case of single mode) or the sum of absolute values (in case of sum mode) is higher than the threshold plus the hysteresis for at least one data acquisition. In bit (0x09) *low_int* the interrupt status is stored.

The relation between the content of (0x22) *low_dur* and the actual delay of the interrupt generation is: $\text{delay [ms]} = [(0x22) \text{ low_dur} + 1] \cdot 2 \text{ ms}$. Therefore, possible delay times range from 2 ms to 512 ms.

4.7.10 High-g interrupt

This interrupt is based on the comparison of acceleration data against a high-g threshold for the detection of shock or other high-acceleration events.

The high-g interrupt is enabled (disabled) per axis by writing “1” (“0”) to bits (0x17) *high_en_x*, (0x17) *high_en_y*, and (0x17) *high_en_z*, respectively. The high-g threshold is set through the (0x26) *high_th* register. The meaning of an LSB of (0x26) *high_th* depends on the selected g-range: it corresponds to 7.81 mg in 2g-range, 15.63 mg in 4g-range, 31.25 mg in 8g-range, and 62.5 mg in 16g-range (i.e. increment depends from g-range setting).

A hysteresis can be selected by setting the (0x24) *high_hy* bits. Analogously to (0x26) *high_th*, the meaning of an LSB of (0x24) *high_hy* is g-range dependent: it corresponds to an acceleration difference of 125 mg in 2g-range, 250 mg in 4g-range, 500 mg in 8g-range, and 1000mg in 16g-range (as well, increment depends from g-range setting).

The high-g interrupt is generated if the absolute value of the acceleration of at least one of the enabled axes (‘or’ relation) is higher than the threshold for at least the time defined by the (0x25) *high_dur* register. The interrupt is reset if the absolute value of the acceleration of all enabled axes (‘and’ relation) is lower than the threshold minus the hysteresis for at least the time defined by the (0x25) *high_dur* register. In bit (0x09) *high_int* the interrupt status is stored. The relation between the content of (0x25) *high_dur* and the actual delay of the interrupt generation is $\text{delay [ms]} = [(0x22) \text{ low_dur} + 1] \cdot 2 \text{ ms}$. Therefore, possible delay times range from 2 ms to 512 ms. The interrupt will be cleared immediately once acceleration is lower than threshold.

4.7.10.1 Axis and sign information of high-g interrupt

The axis which triggered the interrupt is indicated by bits (0x0C) *high_first_x*, (0x0C) *high_first_y*, and (0x0C) *high_first_z*. The bit corresponding to the triggering axis contains a “1” while the other bits hold a “0”. These bits are cleared together with clearing the interrupt status. The sign of the triggering acceleration is stored in bit (0x0C) *high_sign*. If (0x0C) *high_sign* = “0” (“1”), the sign is positive (negative).

4.7.11 No-motion / slow motion detection

The slow-motion/no-motion interrupt engine can be configured in two modes.

In slow-motion mode an interrupt is triggered when the measured slope of at least one enabled axis exceeds the programmable slope threshold for a programmable number of samples. Hence the engine behaves similar to the any-motion interrupt, but with a different set of parameters. In order to suppress false triggers, the interrupt is only generated (cleared) if a certain number N of consecutive slope data points is larger (smaller) than the slope threshold given by $(0x27) slo_no_mot_dur<1:0>$. The number is $N = (0x27) slo_no_mot_dur<1:0> + 1$.

In no-motion mode an interrupt is generated if the slope on all selected axes remains smaller than a programmable threshold for a programmable delay time. Figure 13 shows the timing diagram for the no-motion interrupt. The scaling of the threshold value is identical to that of the slow-motion interrupt. However, in no-motion mode register $(0x27) slo_no_mot_dur$ defines the delay time before the no-motion interrupt is triggered. Table 24 lists the delay times adjustable with register $(0x27) slo_no_mot_dur$. The timer tick period is 1 second. Hence using short delay times can result in considerable timing uncertainty.

If bit $(0x18) slo_no_mot_sel$ is set to '1' ('0') the no-motion/slow-motion interrupt engine is configured in the no-motion (slow-motion) mode. Common to both modes, the engine monitors the slopes of the axes that have been enabled with bits $(0x18) slo_no_mot_en_x$, $(0x18) slo_no_mot_en_y$, and $(0x18) slo_no_mot_en_z$ for the x-axis, y-axis and z-axis, respectively. The measured slope values are continuously compared against the threshold value defined in register $(0x29) slo_no_mot_th$. The scaling is such that 1 LSB of $(0x29) slo_no_mot_th$ corresponds to 3.91 mg in 2g-range (7.81 mg in 4g-range, 15.6 mg in 8g-range and 31.3 mg in 16g-range). Therefore the maximum value is 996 mg in 2g-range (1.99g in 4g-range, 3.98g in 8g-range and 7.97g in 16g-range). The time difference between the successive acceleration samples depends on the selected bandwidth and equates to $1/(2 * bw)$.

Table 24: No-motion time-out periods

$(0x27) slo_no_mot_dur$	Delay time	$(0x27) slo_no_mot_dur$	Delay time	$(0x27) slo_no_mot_dur$	Delay Time
0	1 s	16	40 s	32	88 s
1	2 s	17	48 s	33	96 s
2	3 s	18	56 s	34	104 s
...	...	19	64 s
14	15 s	20	72 s	62	328 s
15	16 s	21	80 s	63	336 s

Note: $slo_no_mot_dur$ values 22 to 31 are not specified

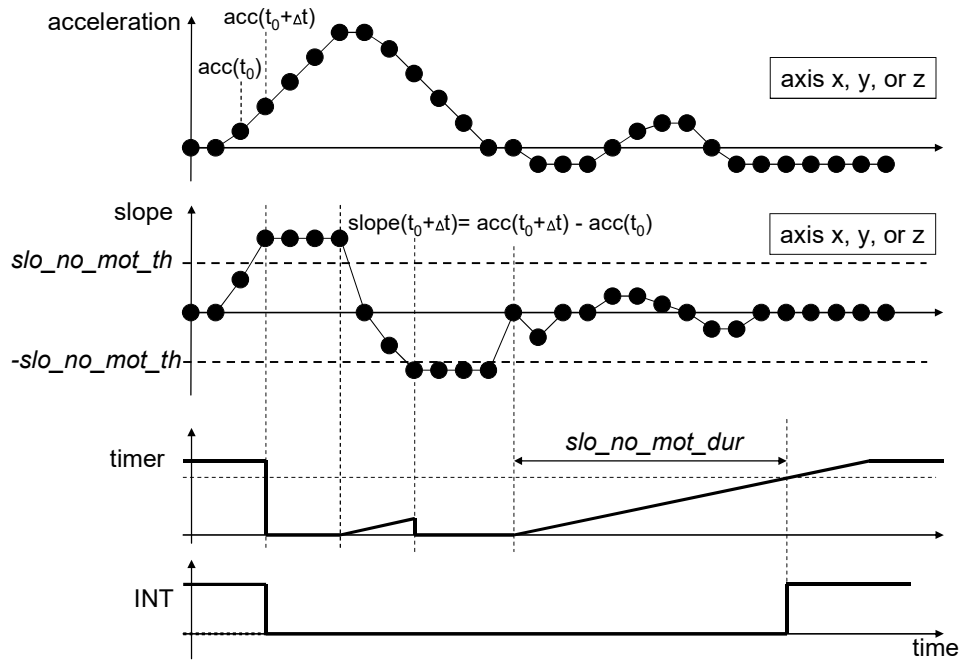

Figure 13: Timing of No-motion interrupt

4.8 Accelerometer softreset

A softreset causes all user configuration settings to be overwritten with their default value and the sensor to enter normal mode.

A softreset is initiated by means of writing value 0xB6 to register (0x14) *softreset*. Subsequently a waiting time of $t_{w,up1}$ (max.) is required prior to accessing any configuration registers.

4.9 Magnetometer interrupt controller

One magnetometer based interrupt engine is integrated in the magnetometer part of BMC156: Data Ready (DRDY).

The Data Ready (DRDY) interrupt is mapped to the DRDY pin of BMC156 when enabled.

When the “Data Ready Pin En” bit (register *0x4E bit7*) is set, the Data Ready (DRDY) interrupt event is flagged on the BMC156’s DRDY output pin (by default the “Data Ready Pin En” bit is not set and DRDY pin is in high-Z state).

The interrupt status register is updated together with writing new data into the magnetic field data registers. The status bits for the Data Ready (DRDY) status flag is located at register *0x48 bit0*.

If DRDY interrupt is disabled, all active status bits and pins are reset after the next measurement was performed.

4.9.1 General features

The Data Ready (DRDY) is always cleared after readout of data registers ends.

After reading the DRDY interrupt status, both the interrupt status bits and the interrupt pin are reset.

DRDY pin polarity can be changed by the “DR polarity” (register *0x4E bit2*), from the default high active (“1”) to low active (“0”).

4.9.2 Electrical behavior of magnetic interrupt pin

The interrupt pin DRDY is push/pull when the corresponding interrupt pin enable bit is set, and is floating (High-Z) when the corresponding interrupt pin enable bit is disabled (default).

4.9.3 Data ready / DRDY interrupt

This interrupt serves for synchronous reading of magnetometer data. It is generated after storing a new set of values (DATA_X, DATA_Y, DATA_Z, RHALL) in the data registers:

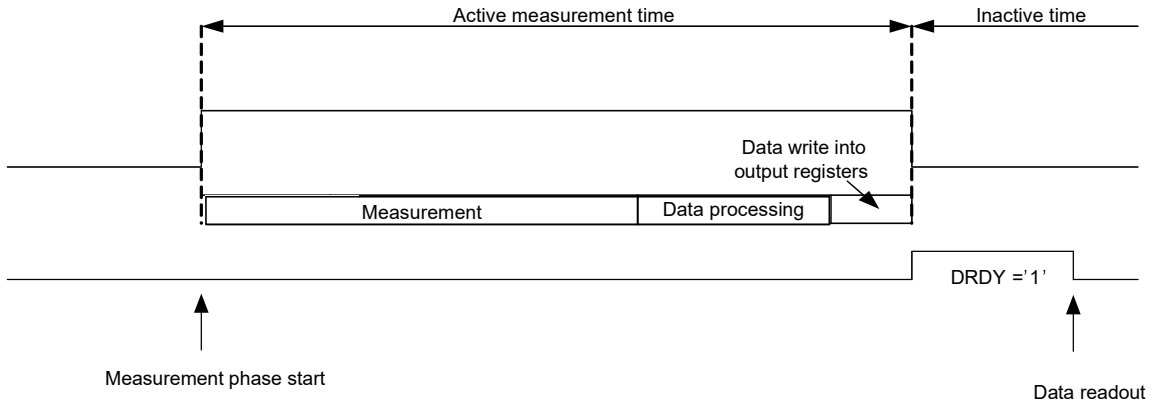

Figure 14: Data acquisition and DRDY operation (DRDY in “high active” polarity)

The interrupt mode of the Data Ready (DRDY) interrupt is fixed to non-latched.
It is enabled (disabled) by writing “1” (“0”) to “Data Ready pin En” in register *0x4E bit7*.

DRDY pin polarity can be changed by the “DR polarity” bit (register *0x4E bit2*), from the default high active (“1”) to low active (“0”).

5. FIFO Operation

5.1 FIFO Operating Modes

The IC of the accelerometer part of BMC156 features an integrated FIFO memory capable of storing up to 32 frames. Conceptually each frame consists of three 16-bit words corresponding to the x, y and z- axis, which are sampled at the same point in time. At the core of the FIFO is a buffer memory, which can be configured to operate in the following modes:

- **FIFO Mode:** In FIFO mode the acceleration data of the selected axes are stored in the buffer memory. If enabled, a watermark interrupt is triggered when the buffer has filled up to a configurable level. The buffer will be continuously filled until the fill level reaches 32 frames. When it is full the data collection is stopped, and all additional samples are ignored. Once the buffer is full, a FIFO-full interrupt is generated if it has been enabled.
- **STREAM Mode:** In STREAM mode the acceleration data of the selected axes are stored in the buffer until it is full. The buffer has a depth of 31 frames. When the buffer is full the data collection continues and oldest entry is discarded. If enabled, a watermark interrupt is triggered when the buffer is filled to a configurable level. Once the buffer is full, a FIFO-full interrupt is generated if it has been enabled.
- **BYPASS Mode:** In bypass mode, only the current sensor data can be read out from the FIFO address. Essentially, the FIFO behaves like the STREAM mode with a depth of 1. Compared to reading the data from the normal data registers, the advantage to the user is that the packages X, Y, Z are from the same timestamp, while the data registers are updated sequentially and hence mixing of data from different axes can occur.

The primary FIFO operating mode is selected with register (0x3E) *fifo_mode* according to '00b' for BYPASS mode, '01b' for FIFO mode, and '10b' for STREAM mode. Writing to register (0x3E) clears the buffer content and resets the FIFO-full and watermark interrupts. When reading register (0x3E) *fifo_mode* always contains the current operating mode.

5.2 FIFO Data Readout

The FIFO stores the data that are also available at the acceleration read-out registers (0x02) to (0x07). Thus, all configuration settings apply to the FIFO data as well as the acceleration data readout registers. The FIFO read out is possible through register (0x3F). The readout can be performed using burst mode since the read address counter is no longer incremented, when it has reached address (0x3F). This implies that the trapping also occurs when the burst read access starts below address (0x3F). A single burst can read out one or more frames at a time. Register (0x3E) *fifo_data_select* controls the acceleration data of which axes are stored in the FIFO. Possible settings for register (0x3E) *fifo_data_select* are '00b' for x, y- and z-axis, '01b' for x-axis only, '10b' for y-axis, '11b' for z-axis only. The depth of the FIFO is independent of whether all or a single axis have been selected. Writing to register (0x3E) clears the buffer content and resets the FIFO-full and watermark interrupts.

If all axes are enabled, the format of the data read-out from register (0x3F) is as follows:

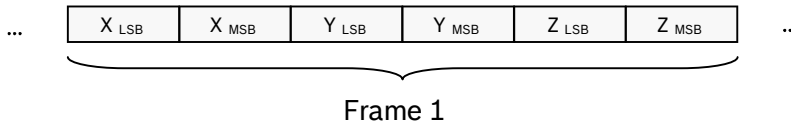

If only one axis is enabled, the format of the data read-out from register (0x3F) is as follows (example shown: y-axis only, other axes are equivalent).

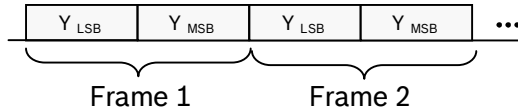

If a frame is not completely read due to an incomplete read operation, the remaining part of the frame is discarded. In this case the FIFO aligns to the next frame during the next read operation. In order for the discarding mechanism to operate correctly, there must be a delay of at least 1.5 us between the last data bit of the partially read frame and the first address bit of the next FIFO read access. Otherwise frames must not be read out partially.

If the FIFO is read beyond the FIFO fill level zeroes (0) will be read. If the FIFO is read beyond the FIFO fill level the read or burst read access time must not exceed the sampling time t_{SAMPLE} . Otherwise frames may be lost.

5.3 FIFO Frame Counter and Overrun Flag

Register (0x0E) *fifo_frame_counter* reflects the current fill level of the buffer. If additional frames are written to the buffer although the FIFO is full, the (0x0E) *fifo_overrun* bit is set to '1'. The FIFO buffer is cleared, the FIFO fill level indicated in register (0x0E) *fifo_frame_counter* and the (0x0E) *fifo_overrun* bit are both set to '0' each time one a write access to one of the FIFO configuration registers (0x3E) or (0x30) occurs. The (0x0E) *fifo_overrun* bit is not reset when the FIFO fill level (0x0E) *fifo_frame_counter* has decremented to '0' due to reading from register (0x3F).

5.4 FIFO Interrupts

The FIFO controller can generate two different interrupt events, a FIFO-full and a watermark event. The FIFO-full and watermark interrupts are functional in all FIFO operating modes. The watermark interrupt is asserted when the fill level in the buffer has reached the frame count defined by register (0x30) *fifo_water_mark_trigger_retain*. In order to enable (disable) the watermark interrupt, the (0x17) *int_fwm_en* bit must be set to '1' ('0'). To map the watermark interrupt signal to INT2 pin, (0x1A) *int2_fwm* bit must be set to '1'. The status of the watermark interrupt may be read back through the (0x0A) *fifo_wm_int* bit. Writing to register (0x30) *fifo_water_mark_trigger_retain* clears the FIFO buffer.

The FIFO-full interrupt is triggered when the buffer has been completely filled. In FIFO mode this occurs 32, in STREAM mode 31 samples, and in BYPASS mode 1 sample after the buffer has been cleared. In order to enable the FIFO-full interrupt, bit (0x17) *int_fful_en* as well as bit (0x1A) *int2_fful* must also be set to '1'. The status of the FIFO-full interrupt may be read back through bit (0x0A) *fifo_full_int*.

6. Accelerometer register description

6.1 General remarks

The entire communication with the device is performed by reading from and writing to registers. Registers have a width of 8 bits; they are mapped to a common space of 64 addresses from $(0x00)$ up to $(0x3F)$. Within the used range there are several registers which are either completely or partially marked as 'reserved'. Any reserved bit is ignored when it is written and no specific value is guaranteed when read. It is recommended not to use registers at all which are completely marked as 'reserved'. Furthermore it is recommended to mask out (logical *and* with zero) reserved bits of registers which are partially marked as reserved.

Registers with addresses from $(0x00)$ up to $(0x0E)$ are read-only. Any attempt to write to these registers is ignored. There are bits within some registers that trigger internal sequences. These bits are configured for write-only access, e. g. $(0x21)$ *reset_int* or the entire $(0x14)$ *softreset* register, and read as value '0'.

6.2 Register map

Register Address	bit7	bit6	bit5	bit4	bit3	bit2	bit1	bit0	Access	Default	
0x3F	fifo_data_output_register<7:0>								ro	0x00	
0x3E	fifo_mode<1:0>							fifo_data_select<1:0>		w/r	0x00
0x3D									w/r	0xFF	
0x3C	GP1<7:0>								w/r	0x00	
0x3B	GP0<7:0>								w/r	0x00	
0x3A	offset_z<7:0>								w/r	0x00	
0x39	offset_y<7:0>								w/r	0x00	
0x38	offset_x<7:0>								w/r	0x00	
0x37	offset_target_z<1:0>			offset_target_y<1:0>		offset_target_x<1:0>		cut_off		w/r	0x00
0x36	offset_reset	cal_trigger<1:0>		cal_rdy	hp_z_en		hp_y_en	hp_x_en	w/r	0x10	
0x35									w/r	0x00	
0x34									w/r	0x00	
0x33	nvm_remain<3:0>			nvm_load		i2c_wdt_en	i2c_wdt_sel	spi3	w/r	0x00	
0x32	self_test_amp		self_test_sign		self_test_axis<1:0>				w/r	0x00	
0x31									w/r	0xFF	
0x30	fifo_water_mark_level_trigger_retain<5:0>								w/r	0x00	
0x2F	flat_hold_time<1:0>				flat_hy<2:0>				w/r	0x11	
0x2E	flat_theta<5:0>								w/r	0x08	
0x2D	orient_ud_en		orient_theta<5:0>			orient_blocking<1:0>			orient_mode<1:0>	w/r	0x48
0x2C	orient_hyst<2:0>		orient_blocking<1:0>		orient_mode<1:0>				w/r	0x18	
0x2B	tap_samp<1:0>		tap_th<4:0>				tap_dur<2:0>		w/r	0x0A	
0x2A	tap_quiet	tap_shock							w/r	0x04	
0x29	slo_no_mot_th<7:0>								w/r	0x14	
0x28	slope_th<7:0>								w/r	0x14	
0x27	slo_no_mot_dur<5:0>				slope_dur<1:0>				w/r	0x00	
0x26	high_th<7:0>				high_dur<7:0>				w/r	0xC0	
0x25	high_hy<1:0>				low_mode				low_hy<1:0>	w/r	0x81
0x24	low_th<7:0>								w/r	0x30	
0x23	low_dur<7:0>								w/r	0x09	
0x22	latch_int<3:0>								w/r	0x00	
0x21	reset_int	int2_od		int2_iv						w/r	0x05
0x20									w/r	0xFF	
0x1F									w/r	0xFF	
0x1E	int_src_data		int_src_tap	int_src_slo_no_mot	int_src_slope	int_src_high	int_src_low		w/r	0x00	
0x1D									w/r	0xFF	
0x1C									w/r	0xFF	
0x1B	int2_flat	int2_orient	int2_s_tap	int2_d_tap	int2_slo_no_mot	int2_slope	int2_high	int2_low	w/r	0x00	
0x1A	int2_data	int2_fw_m	int2_full							w/r	0x00
0x19									w/r	0x00	
0x18	slo_no_mot_sel		slo_no_mot_en_z	slo_no_mot_en_y	slo_no_mot_en_x				w/r	0x00	
0x17	int_fw_m_en	int_full_en	data_en	low_en	high_en_z	high_en_y	high_en_x		w/r	0x00	
0x16	flat_en	orient_en	s_tap_en	d_tap_en	slope_en_z	slope_en_y	slope_en_x		w/r	0x00	
0x15									w/r	0xFF	
0x14	softreset								wo	0x00	
0x13	data_high_bw	shadow_dis							w/r	0x00	
0x12	lowpower_mode	sleep_timer_mode							w/r	0x00	
0x11	suspend	lowpower_en	deep_suspend	sleep_dur<3:0>						w/r	0x00
0x10	bw<4:0>								w/r	0x0F	
0x0F	range<3:0>								w/r	0x03	
0x0E	fifo_overrun	fifo_frame_counter<6:0>								ro	0x00
0x0D									w/r	0xFF	
0x0C	flat	orient<2:0>		high_sign	high_first_z	high_first_y	high_first_x		ro	0x00	
0x0B	tap_sign	tap_first_z	tap_first_y	tap_first_x	slope_sign	slope_first_z	slope_first_y	slope_first_x	ro	0x00	
0x0A	data_int	fifo_wm_int	fifo_full_int							ro	0x00
0x09	flat_int	orient_int	s_tap_int	d_tap_int	slo_no_mot_int	slope_int	high_int	low_int	ro	0x00	
0x08	temp<7:0>								ro	0x00	
0x07	acc_z_msb<11:4>								ro	0x00	
0x06	acc_z_lsb<3:0>							new_data_z		ro	0x00
0x05	acc_y_msb<11:4>								ro	0x00	
0x04	acc_y_lsb<3:0>							new_data_y		ro	0x00
0x03	acc_x_msb<11:4>								ro	0x00	
0x02	acc_x_lsb<3:0>							new_data_x		ro	0x00
0x01									ro	-	
0x00	chip_id<7:0>								ro	0xFA	

common w/r registers: Application specific settings which are not equal to the default settings, must be re-set to its designated values after POR, soft-reset and wake up from deep suspend.

user w/r registers: Initial default content = 0x00. Freely programmable by the user. Remains unchanged after POR, soft-reset and wake up from deep suspend.

Figure 15: Register map

6.3 Chip ID

Register 0x00 (BGW_CHIPID)

The register contains the chip identification code.

Name	0x00	BGW_CHIPID		
Bit	7	6	5	4
Read/Write	R	R	R	R
Reset Value	n/a	n/a	n/a	n/a
Content	chip_id<7:4>			
Bit	3	2	1	0
Read/Write	R	R	R	R
Reset Value	n/a	n/a	n/a	n/a
Content	chip_id<3:0>			

chip_id<7:0>: Fixed value b'1111'1010

6.4 Acceleration data

Register 0x02 (ACCD_X_LSB)

The register contains the least-significant bits of the X-channel acceleration readout value. When reading out X-channel acceleration values, data consistency is guaranteed if the ACCD_X_LSB is read out before the ACCD_X_MSB and shadow_dis='0'. In this case, after the ACCD_X_LSB has been read, the value in the ACCD_X_MSB register is locked until the ACCD_X_MSB has been read. This condition is inherently fulfilled if a burst-mode read access is performed. Acceleration data may be read from register ACCD_X_LSB at any time except during power-up and in DEEP_SUSPEND mode.

Name	0x02		ACCD_X_LSB	
Bit	7	6	5	4
Read/Write	R	R	R	R
Reset Value	n/a	n/a	n/a	n/a
Content	acc_x_lsb<3:0>			
Bit	3	2	1	0
Read/Write	R	R	R	R
Reset Value	n/a	n/a	n/a	n/a
Content	undefined	undefined	'0'	new_data_x

acc_x_lsb<3:0>: Least significant 4 bits of acceleration read-back value; (two's-complement format)

undefined: random data; to be ignored.

New_data_x: '0': acceleration value has not been updated since it has been read out last
 '1': acceleration value has been updated since it has been read out last

Register 0x03 (ACCD_X_MSB)

The register contains the most-significant bits of the X-channel acceleration readout value. When reading out X-channel acceleration values, data consistency is guaranteed if the ACCD_X_LSB is read out before the ACCD_X_MSB and shadow_dis='0'. In this case, after the ACCD_X_LSB has been read, the value in the ACCD_X_MSB register is locked until the ACCD_X_MSB has been read. This condition is inherently fulfilled if a burst-mode read access is performed. Acceleration data may be read from register ACCD_X_MSB at any time except during power-up and in DEEP_SUSPEND mode.

Name	0x03	ACCD_X_MSB		
Bit	7	6	5	4
Read/Write	R	R	R	R
Reset Value	n/a	n/a	n/a	n/a
Content	acc_x_msb<11:8>			
Bit	3	2	1	0
Read/Write	R	R	R	R
Reset Value	n/a	n/a	n/a	n/a
Content	acc_x_msb<7:4>			

acc_x_msb<11:4>: Most significant 8 bits of acceleration readback value (two's-complement format)

Register 0x04 (ACCD_Y_LSB)

The register contains the least-significant bits of the Y-channel acceleration readout value. When reading out Y-channel acceleration values, data consistency is guaranteed if the ACCD_Y_LSB is read out before the ACCD_Y_MSB and shadow_dis='0'. In this case, after the ACCD_Y_LSB has been read, the value in the ACCD_Y_MSB register is locked until the ACCD_Y_MSB has been read. This condition is inherently fulfilled if a burst-mode read access is performed. Acceleration data may be read from register ACCD_Y_LSB at any time except during power-up and in DEEP_SUSPEND mode.

Name	0x04	ACCD_Y_LSB		
Bit	7	6	5	4
Read/Write	R	R	R	R
Reset Value	n/a	n/a	n/a	n/a
Content	acc_y_lsb<3:0>			
Bit	3	2	1	0
Read/Write	R	R	R	R
Reset Value	n/a	n/a	n/a	n/a
Content	undefined	undefined	'0'	new_data_y

acc_y_lsb<3:0>: Least significant 4 bits of acceleration readback value; (two's-complement format)

undefined: random data; to be ignored

new_data_y: '0': acceleration value has not been updated since it has been read out last
 '1': acceleration value has been updated since it has been read out last

Register 0x05 (ACCD_Y_MSB)

The register contains the most-significant bits of the Y-channel acceleration readout value. When reading out Y-channel acceleration values, data consistency is guaranteed if the ACCD_Y_LSB is read out before the ACCD_Y_MSB and shadow_dis='0'. In this case, after the ACCD_Y_LSB has been read, the value in the ACCD_Y_MSB register is locked until the ACCD_Y_MSB has been read. This condition is inherently fulfilled if a burst-mode read access is performed. Acceleration data may be read from register ACCD_Y_MSB at any time except during power-up and in DEEP_SUSPEND mode.

Name	0x05	ACCD_Y_MSB			
Bit	7	6	5	4	
Read/Write	R	R	R	R	
Reset Value	n/a	n/a	n/a	n/a	
Content	acc_y_msb<11:8>				
Bit	3	2	1	0	
Read/Write	R	R	R	R	
Reset Value	n/a	n/a	n/a	n/a	
Content	acc_y_msb<7:4>				

acc_y_msb<11:4>: Most significant 8 bits of acceleration readback value (two's-complement format)

Register 0x06 (ACCD_Z_LSB)

The register contains the least-significant bits of the Z-channel acceleration readout value. When reading out Z-channel acceleration values, data consistency is guaranteed if the ACCD_Z_LSB is read out before the ACCD_Z_MSB and shadow_dis='0'. In this case, after the ACCD_Z_LSB has been read, the value in the ACCD_Z_MSB register is locked until the ACCD_Z_MSB has been read. This condition is inherently fulfilled if a burst-mode read access is performed. Acceleration data may be read from register ACCD_Z_LSB at any time except during power-up and in DEEP_SUSPEND mode.

Name	0x06	ACCD_Z_LSB		
Bit	7	6	5	4
Read/Write	R	R	R	R
Reset Value	n/a	n/a	n/a	n/a
Content	acc_z_lsb<3:0>			
Bit	3	2	1	0
Read/Write	R	R	R	R
Reset Value	n/a	n/a	n/a	n/a
Content	undefined	undefined	'0'	new_data_z

Acc_z_lsb<3:0>: Least significant 4 bits of acceleration readback value; (two's-complement format)

undefined: random data; to be ignored

new_data_z: '0': acceleration value has not been updated since it has been read out last
 '1': acceleration value has been updated since it has been read out last

Register 0x07 (ACCD_Z_MSB)

The register contains the most-significant bits of the Z-channel acceleration readout value. When reading out Z-channel acceleration values, data consistency is guaranteed if the ACCD_Z_LSB is read out before the ACCD_Z_MSB and shadow_dis='0'. In this case, after the ACCD_Z_LSB has been read, the value in the ACCD_Z_MSB register is locked until the ACCD_Z_MSB has been read. This condition is inherently fulfilled if a burst-mode read access is performed. Acceleration data may be read from register ACCD_Z_MSB at any time except during power-up and in DEEP_SUSPEND mode.

Name	0x07	ACCD_Z_MSB			
Bit	7	6	5	4	
Read/Write	R	R	R	R	
Reset Value	n/a	n/a	n/a	n/a	
Content	acc_z_msb<11:8>				
Bit	3	2	1	0	
Read/Write	R	R	R	R	
Reset Value	n/a	n/a	n/a	n/a	
Content	acc_z_msb<7:4>				

acc_z_msb<11:4>: Most significant 8 bits of acceleration readback value (two's-complement format)

6.5 Temperature data

Register 0x08 (ACCD_TEMP)

The register contains the current chip temperature represented in two's complement format. A readout value of temp<7:0>=0x00 corresponds to a temperature of 23°C.

Name	0x08	ACCD_TEMP		
Bit	7	6	5	4
Read/Write	R	R	R	R
Reset Value	n/a	n/a	n/a	n/a
Content	temp<7:4>			
Bit	3	2	1	0
Read/Write	R	R	R	R
Reset Value	n/a	n/a	n/a	n/a
Content	temp<3:0>			

temp<7:0>: Temperature value (two s-complement format)

6.6 Status registers

Register 0x09 (INT_STATUS_0)

The register contains interrupt status flags. Each flag is associated with a specific interrupt function. It is set when the associated interrupt triggers. The setting of latch_int<3:0> controls if the interrupt signal and hence the respective interrupt flag will be permanently latched, temporarily latched or not latched. The interrupt function associated with a specific status flag must be enabled.

Name	0x09	INT_STATUS_0			
Bit	7	6	5	4	
Read/Write	R	R	R	R	
Reset Value	n/a	n/a	n/a	n/a	
Content	flat_int	orient_int	s_tap_int	d_tap_int	
Bit	3	2	1	0	
Read/Write	R	R	R	R	
Reset Value	n/a	n/a	n/a	n/a	
Content	slo_no_mot_int	slope_int	high_int	low_int	

flat_int:	flat interrupt status: '0'→inactive, '1' →active
orient_int :	orientation interrupt status : '0'→inactive, '1' →active
s_tap_int:	single tap interrupt status: '0'→inactive, '1' →active
d_tap_int	double tap interrupt status: '0'→inactive, '1' →active
slo_not_mot_int:	slow/no-motion interrupt status: '0'→inactive, '1' →active
slope_int:	slope interrupt status: '0'→inactive, '1' →active
high_int:	high-g interrupt status: '0'→inactive, '1' →active
low_int:	low-g interrupt status: '0'→inactive, '1' →active

Register 0x0A (INT_STATUS_1)

The register contains interrupt status flags. Each flag is associated with a specific interrupt function. It is set when the associated interrupt engine triggers. The setting of latch_int<3:0> controls if the interrupt signal and hence the respective interrupt flag will be permanently latched, temporarily latched or not latched. The interrupt function associated with a specific status flag must be enabled.

Name	0x0A	INT_STATUS_1		
Bit	7	6	5	4
Read/Write	R	R	R	R
Reset Value	n/a	n/a	n/a	n/a
Content	data_int	fifo_wm_int	fifo_full_int	reserved
Bit	3	2	1	0
Read/Write	R	R	R	R
Reset Value	n/a	n/a	n/a	n/a
Content	reserved			

data_int: data ready interrupt status: '0' → inactive, '1' → active
 fifo_wm_int: FIFO watermark interrupt status: '0' → inactive, '1' → active
 fifo_full_int: FIFO full interrupt status: '0' → inactive, '1' → active
 reserved: reserved, write to '0'

Register 0x0B (INT_STATUS_2)

The register contains interrupt status flags. Each flag is associated with a specific interrupt engine. It is set when the associated interrupt engine triggers. The setting of latch_int<3:0> controls if the interrupt signal and hence the respective interrupt flag will be permanently latched, temporarily latched or not latched. The interrupt function associated with a specific status flag must be enabled.

Name	0x0B	INT_STATUS_2		
Bit	7	6	5	4
Read/Write	R	R	R	R
Reset Value	n/a	n/a	n/a	n/a
Content	tap_sign	tap_first_z	tap_first_y	tap_first_x
Bit	3	2	1	0
Read/Write	R	R	R	R
Reset Value	n/a	n/a	n/a	n/a
Content	slope_sign	slope_first_z	slope_first_y	slope_first_x

tap_sign: sign of single/double tap triggering signal was '0' → positive, or '1' → negative
 tap_first_z: single/double tap interrupt: '1' → triggered by, or '0' → not triggered by z-axis
 tap_first_y: single/double tap interrupt: '1' → triggered by, or '0' → not triggered by y-axis
 tap_first_x: single/double tap interrupt: '1' → triggered by, or '0' → not triggered by x-axis
 slope_sign: slope sign of slope tap triggering signal was '0' → positive, or '1' → negative
 slope_first_z: slope interrupt: '1' → triggered by, or '0' → not triggered by z-axis
 slope_first_y: slope interrupt: '1' → triggered by, or '0' → not triggered by y-axis
 slope_first_x: slope interrupt: '1' → triggered by, or '0' → not triggered by x-axis

Register 0x0C (INT_STATUS_3)

The register contains interrupt status flags. Each flag is associated with a specific interrupt engine. It is set when the associated interrupt engine triggers. With the exception of orient<3:0> the setting of latch_int<3:0> controls if the interrupt signal and hence the respective interrupt flag will be permanently latched, temporarily latched or not latched. The interrupt function associated with a specific status flag must be enabled.

Name	0x0C	INT_STATUS_3		
Bit	7	6	5	4
Read/Write	R	R	R	R
Reset Value	n/a	n/a	n/a	n/a
Content	flat	orient<2:0>		
Bit	3	2	1	0
Read/Write	R	R	R	R
Reset Value	n/a	n/a	n/a	n/a
Content	high_sign	high_first_z	high_first_y	high_first_x

flat: device is in '1' → flat, or '0' → non flat position;
only valid if (0x16) flat_en = '1'

orient<2>: Orientation value of z-axis: '0' → upward looking, or '1' → downward looking. The flag always reflect the current orientation status, independent of the setting of latch_int<3:0>. The flag is not updated as long as an orientation blocking condition is active.

Orient<1:0>: orientation value of x-y-plane:
'00' → portrait upright; '01' → portrait upside down;
'10' → landscape left; '11' → landscape right;
The flags always reflect the current orientation status, independent of the setting of latch_int<3:0>. The flag is not updated as long as an orientation blocking condition is active.

High_sign: sign of acceleration signal that triggered high-g interrupt was '0' → positive, '1' → negative

high_first_z: high-g interrupt: '1' → triggered by, or '0' → not triggered by z-axis

high_first_y: high-g interrupt: '1' → triggered by, or '0' → not triggered by y-axis

high_first_x: high-g interrupt: '1' → triggered by, or '0' → not triggered by x-axis

Register 0x0E (FIFO_STATUS)

The register contains FIFO status flags.

Name	0x0E	FIFO_STATUS		
Bit	7	6	5	4
Read/Write	R	R	R	R
Reset Value	n/a	n/a	n/a	n/a
Content	fifo_overnun	fifo_frame_counter<6:4>		

Bit	3	2	1	0
Read/Write	R	R	R	R
Reset Value	n/a	n/a	n/a	n/a
Content	fifo_frame_counter<3:0>			

fifo_overnun: FIFO overrun condition has '1' → occurred, or '0' → not occurred; flag can be cleared by writing to the FIFO configuration register FIFO_CONFIG_1 only

fifo_frame_counter<6:4>: Current fill level of FIFO buffer. An empty FIFO corresponds to 0x00. The frame counter can be cleared by reading out all frames from the FIFO buffer or writing to the FIFO configuration register FIFO_CONFIG_1.

6.7 g-range selection

Register 0x0F (PMU_RANGE)

The register allows the selection of the accelerometer g-range.

Name	0x0F	PMU_RANGE			
Bit	7	6	5	4	
Read/Write	R/W	R/W	R/W	R/W	
Reset Value	0	0	0	0	
Content	reserved				
Bit	3	2	1	0	
Read/Write	R/W	R/W	R/W	R/W	
Reset Value	0	0	1	1	
Content	range<3:0>				

range<3:0>: Selection of accelerometer g-range:
 '0011b' → ±2g range; '0101b' → ±4g range; '1000b' → ±8g range;
 '1100b' → ±16g range; all other settings → reserved (do not use)

reserved: write '0'

6.8 Bandwidths

Register 0x10 (PMU_BW)

The register allows the selection of the acceleration data filter bandwidth.

Name	0x10	PMU_BW			
Bit	7	6	5	4	
Read/Write	R/W	R/W	R/W	R/W	
Reset Value	0	0	0	0	
Content	reserved			bw<4>	
Bit	3	2	1	0	
Read/Write	R/W	R/W	R/W	R/W	
Reset Value	1	1	1	1	
Content	bw<3:0>				

bw<4:0>: Selection of data filter bandwidth:
 '00xxx⁰b' → 7.81 Hz, '01000b' → 7.81 Hz, '01001b' → 15.63 Hz,
 '01010b' → 31.25 Hz, '01011b' → 62.5 Hz, '01100b' → 125 Hz,
 '01101b' → 250 Hz, '01110b' → 500 Hz, '01111b' → 1000 Hz,
 '1xxxxb' → 1000 Hz

reserved: write '0'

6.9 Power modes

Register 0x11 (PMU_LPW)

Selection of the main power modes and the low power sleep period.

Name	0x11	PMU_LPW		
Bit	7	6	5	4
Read/Write	R/W	R/W	R/W	R/W
Reset Value	0	0	0	0
Content	suspend	lowpower_en	deep_suspend	sleep_dur<3>
Bit	3	2	1	0
Read/Write	R/W	R/W	R/W	R/W
Reset Value	0	0	0	0
Content	sleep_dur<2:0>			reserved

suspend, low_power_en, deep_suspend:

Main power mode configuration setting {suspend; lowpower_en; deep_suspend}:

- {0; 0; 0} → NORMAL mode;
- {0; 0; 1} → DEEP_SUSPEND mode;
- {0; 1; 0} → LOW_POWER mode;
- {1; 0; 0} → SUSPEND mode;
- {all other} → illegal

Please note that only certain power mode transitions are permitted.

Sleep_dur<3:0>: Configures the sleep phase duration in LOW_POWER mode:

- '0000b' to '0101b' → 0.5 ms, '0110b' → 1 ms,
- '0111b' → 2 ms, '1000b' → 4 ms,
- '1001b' → 6 ms, '1010b' → 10 ms,
- '1011b' → 25 ms, '1100b' → 50 ms,
- '1101b' → 100 ms, '1110b' → 500 ms,
- '1111b' → 1 s

Register 0x12 (PMU_LOW_POWER)

Configuration settings for low power mode.

Name	0x12	PMU_LOW_POWER		
Bit	7	6	5	4
Read/Write	R/W	R/W	R/W	R/W
Reset Value	0	0	0	0
Content	reserved	lowpower_mode	sleeptimer_mode	reserved

Bit	3	2	1	0
Read/Write	R/W	R/W	R/W	R/W
Reset Value	0	0	0	0
Content	reserved			

lowpower_mode: select '0' → LPM1, or '1' → LPM2 configuration for SUSPEND and LOW_POWER mode. In the LPM1 configuration the power consumption in LOW_POWER mode and SUSPEND mode is significantly reduced when compared to LPM2 configuration, but the FIFO is not accessible and writing to registers must be slowed down. In the LPM2 configuration the power consumption in LOW_POWER mode is reduced compared to NORMAL mode, but the FIFO is fully accessible and registers can be written to at full speed.

Sleeptimer_mode: when in LOW_POWER mode '0' → use event-driven time-base mode (compatible with BMA250), or '1' → use equidistant sampling time-base mode. Equidistant sampling of data into the FIFO is maintained in equidistant time-base mode only.

Reserved: write '0'

6.10 Special control settings

Register 0x13 (ACCD_HBW)

Acceleration data acquisition and data output format.

Name	0x13 ACCD_HBW			
Bit	7	6	5	4
Read/Write	R/W	R/W	R/W	R/W
Reset Value	0	0 (1 in 8-bit mode)	0	0
Content	data_high_bw	shadow_dis	reserved	
Bit	3	2	1	0
Read/Write	R/W	R/W	R/W	R/W
Reset Value	0	0	0	0
Content	reserved			

data_high_bw: select whether '1' → unfiltered, or '0' → filtered data may be read from the acceleration data registers.

Shadow_dis: '1' → disable, or '0' → the shadowing mechanism for the acceleration data output registers. When shadowing is enabled, the content of the acceleration data component in the MSB register is locked, when the component in the LSB is read, thereby ensuring the integrity of the acceleration data during read-out. The lock is removed when the MSB is read.

Reserved: write '1'

Register 0x14 (BGW_SOFTRESET)

Controls user triggered reset of the sensor.

Name	0x14	BGW_SOFTRESET		
Bit	7	6	5	4
Read/Write	W	W	W	W
Reset Value	0	0	0	0
Content	softreset			
Bit	3	2	1	0
Read/Write	W	W	W	W
Reset Value	0	0	0	0
Content	softreset			

softreset:

0xB6 → triggers a reset. Other values are ignored. Following a delay, all user configuration settings are overwritten with their default state or the setting stored in the NVM, wherever applicable. This register is functional in all operation modes. Please note that all application specific settings which are not equal to the default settings (refer to chapter 6.2), must be reconfigured to their designated values.

6.11 Interrupt settings

Register 0x16 (INT_EN_0)

Controls which interrupt engines in group 0 are enabled.

Name	0x16	INT_EN_0		
Bit	7	6	5	4
Read/Write	R/W	R/W	R/W	R/W
Reset Value	0	0	0	0
Content	flat_en	orient_en	s_tap_en	d_tap_en
Bit	3	2	1	0
Read/Write	R/W	R/W	R/W	R/W
Reset Value	0	0	0	0
Content	reserved	slope_en_z	slope_en_y	slope_en_x

flat_en:	flat interrupt: '0'→disabled, or '1' →enabled
orient_en:	orientation interrupt: '0'→disabled, or '1' →enabled
s_tap_en:	single tap interrupt: '0'→disabled, or '1' →enabled
d_tap_en:	double tap interrupt: '0'→disabled, or '1' →enabled
reserved:	write '0'
slope_en_z:	slope interrupt, z-axis component: '0'→disabled, or '1' →enabled
slope_en_y:	slope interrupt, y-axis component: '0'→disabled, or '1' →enabled
slope_en_x:	slope interrupt, x-axis component: '0'→disabled, or '1' →enabled

Register 0x17 (INT_EN_1)

Controls which interrupt engines in group 1 are enabled.

Name	0x17	INT_EN_1		
Bit	7	6	5	4
Read/Write	R/W	R/W	R/W	R/W
Reset Value	0	0	0	0
Content	reserved	int_fwm_en	int_full_en	data_en
Bit	3	2	1	0
Read/Write	R/W	R/W	R/W	R/W
Reset Value	0	0	0	0
Content	low_en	high_en_z	high_en_y	high_en_x

reserved: write '0'
 int_fwm_en: FIFO watermark interrupt: '0'→disabled, or '1' →enabled
 int_full_en: FIFO full interrupt: '0'→disabled, or '1' →enabled
 data_en: data ready interrupt: '0'→disabled, or '1' →enabled
 low_en: low-g interrupt: '0'→disabled, or '1' →enabled
 high_en_z: high-g interrupt, z-axis component: '0'→disabled, or '1' →enabled
 high_en_y: high-g interrupt, y-axis component: '0'→disabled, or '1' →enabled
 high_en_x: high-g interrupt, x-axis component: '0'→disabled, or '1' →enabled

Register 0x18 (INT_EN_2)

Controls which interrupt engines in group 2 are enabled.

Name	0x18	INT_EN_2		
Bit	7	6	5	4
Read/Write	R/W	R/W	R/W	R/W
Reset Value	0	0	0	0
Content	reserved			
Bit	3	2	1	0
Read/Write	R/W	R/W	R/W	R/W
Reset Value	0	0	0	0
Content	slo_no_mot_sel	slo_no_mot_en_z	slo_no_mot_en_y	slo_no_mot_en_x

reserved: write '0'
 slo_no_mot_sel: select '0'→slow-motion, '1' →no-motion interrupt function
 slo_no_mot_en_z: slow/n-motion interrupt, z-axis component: '0'→disabled, or '1' →enabled
 slo_no_mot_en_y: slow/n-motion interrupt, y-axis component: '0'→disabled, or '1' →enabled
 slo_no_mot_en_x: slow/n-motion interrupt, x-axis component: '0'→disabled, or '1' →enabled

Register 0x1A (INT_MAP_1)

Controls which interrupt signals are mapped to the - INT2 pin.

Name	0x1A	INT_MAP_1		
Bit	7	6	5	4
Read/Write	R/W	R/W	R/W	R/W
Reset Value	0	0	0	0
Content	int2_data	int2_fwm	int2_full	reserved
Bit	3	2	1	0
Read/Write	R/W	R/W	R/W	R/W
Reset Value	0	0	0	0
Content	reserved	reserved	reserved	reserved

int2_data: map data ready interrupt to INT2 pin: '0'→disabled, or '1' →enabled
 int2_fwm: map FIFO watermark interrupt to INT2 pin: '0'→disabled, or '1' →enabled
 int2_full: map FIFO full interrupt to INT2 pin: '0'→disabled, or '1' →enabled
 reserved: write '0'

Register 0x1B (INT_MAP_2)

Controls which interrupt signals are mapped to the INT2 pin.

Name	0x1B	INT_MAP_2		
Bit	7	6	5	4
Read/Write	R/W	R/W	R/W	R/W
Reset Value	0	0	0	0
Content	int2_flat	int2_orient	int2_s_tap	int2_d_tap
Bit	3	2	1	0
Read/Write	R/W	R/W	R/W	R/W
Reset Value	0	0	0	0
Content	int2_slo_no_mot	int2_slope	int2_high	int2_low

int2_flat: map flat interrupt to INT2 pin: '0'→disabled, or '1' →enabled
 int2_orient: map orientation interrupt to INT2 pin: '0'→disabled, or '1' →enabled
 int2_s_tap: map single tap interrupt to INT2 pin: '0'→disabled, or '1' →enabled
 int2_d_tap: map double tap interrupt to INT2 pin: '0'→disabled, or '1' →enabled
 int2_slo_no_mot: map slow/no-motion interrupt to INT2 pin: '0'→disabled, or '1' →enabled
 int2_slope: map slope interrupt to INT2 pin: '0'→disabled, or '1' →enabled
 int2_high: map high-g to INT2 pin: '0'→disabled, or '1' →enabled
 int2_low: map low-g to INT2 pin: '0'→disabled, or '1' →enabled

Register 0x1E (INT_SRC)

Contains the data source definition for interrupts with selectable data source.

Name	0x1E	INT_SRC		
Bit	7	6	5	4
Read/Write	R/W	R/W	R/W	R/W
Reset Value	0	0	0	0
Content	reserved		int_src_data	int_src_tap
Bit	3	2	1	0
Read/Write	R/W	R/W	R/W	R/W
Reset Value	0	0	0	0
Content	int_src_slo_no_mot	int_src_slope	int_src_high	int_src_low

reserved: write '0'
 int_src_data: select '0' → filtered, or '1' → unfiltered data for new data interrupt
 int_src_tap: select '0' → filtered, or '1' → unfiltered data for single-/double tap interrupt
 int_src_slo_no_mot: select '0' → filtered, or '1' → unfiltered data for slow/no-motion interrupt
 int_src_slope: select '0' → filtered, or '1' → unfiltered data for slope interrupt
 int_src_high: select '0' → filtered, or '1' → unfiltered data for high-g interrupt
 int_src_low: select '0' → filtered, or '1' → unfiltered data for low-g interrupt

Register 0x20 (INT_OUT_CTRL)

Contains the behavioural configuration (electrical behavior) of the interrupt pins.

Name	0x20	INT_OUT_CTRL		
Bit	7	6	5	4
Read/Write	R/W	R/W	R/W	R/W
Reset Value	0	0	0	0
Content	reserved			
Bit	3	2	1	0
Read/Write	R/W	R/W	R/W	R/W
Reset Value	0	1	0	1
Content	int2_od	int2_lvl	reserved	reserved

reserved: write '0'
 int2_od: select '0' → push-pull, or '1' → open drain behavior for INT2 pin
 int2_lvl: select '0' → active low, or '1' → active high level for INT2 pin

Register 0x21 (INT_RST_LATCH)

Contains the interrupt reset bit and the interrupt mode selection.

Name	0x21	INT_RST_LATCH		
Bit	7	6	5	4
Read/Write	W	R/W	R/W	R/W
Reset Value	0	0	0	0
Content	reset_int	reserved		
Bit	3	2	1	0
Read/Write	R/W	R/W	R/W	R/W
Reset Value	0	0	0	0
Content	latch_int<3:0>			

reset_int: write '1' → clear any latched interrupts, or '0' → keep latched interrupts active

reserved: write '0'

latch_int<3:0>: '0000b' → non-latched, '0001b' → temporary, 250 ms,
 '0010b' → temporary, 500 ms, '0011b' → temporary, 1 s,
 '0100b' → temporary, 2 s, '0101b' → temporary, 4 s,
 '0110b' → temporary, 8 s, '0111b' → latched,
 '1000b' → non-latched, '1001b' → temporary, 250 μs,
 '1010b' → temporary, 500 μs, '1011b' → temporary, 1 ms,
 '1100b' → temporary, 12.5 ms, '1101b' → temporary, 25 ms,
 '1110b' → temporary, 50 ms, '1111b' → latched

Register 0x22 (INT_0)

Contains the delay time definition for the low-g interrupt.

Name	0x22	INT_0		
Bit	7	6	5	4
Read/Write	W	R/W	R/W	R/W
Reset Value	0	0	0	0
Content	low_dur<7:4>			
Bit	3	2	1	0
Read/Write	R/W	R/W	R/W	R/W
Reset Value	1	0	0	1
Content	low_dur<3:0>			

low_dur<7:0>: low-g interrupt trigger delay according to $[low_dur<7:0> + 1] \cdot 2$ ms in a range from 2 ms to 512 ms; the default corresponds to a delay of 20 ms.

Register 0x23 (INT_1)

Contains the threshold definition for the low-g interrupt.

Name	0x23	INT_1		
Bit	7	6	5	4
Read/Write	W	R/W	R/W	R/W
Reset Value	0	0	1	1
Content	low_th<7:4>			
Bit	3	2	1	0
Read/Write	R/W	R/W	R/W	R/W
Reset Value	0	0	0	0
Content	low_th<3:0>			

low_th<7:0>: low-g interrupt trigger threshold according to *low_th<7:0>* • 7.81 mg in a range from 0 g to 1.992 g; the default value corresponds to an acceleration of 375 mg

Register 0x24 (INT_2)

Contains the low-g interrupt mode selection, the low-g interrupt hysteresis setting, and the high-g interrupt hysteresis setting.

Name	0x24	INT_2		
Bit	7	6	5	4
Read/Write	R/W	R/W	R/W	R/W
Reset Value	1	0	0	0
Content	high_hy<1:0>		reserved	
Bit	3	2	1	0
Read/Write	R/W	R/W	R/W	R/W
Reset Value	0	0	0	1
Content	reserved	low_mode	low_hy<1:0>	

high_hy<1:0>: hysteresis of high-g interrupt according to *high_hy<1:0>* • 125 mg (2-g range), *high_hy<1:0>* • 250 mg (4-g range), *high_hy<1:0>* • 500 mg (8-g range), or *high_hy<1:0>* • 1000 mg (16-g range)

low_mode: select low-g interrupt '0' single-axis mode, or '1' axis-summing mode

low_hy<1:0>: hysteresis of low-g interrupt according to *low_hy<1:0>* • 125 mg independent of the selected accelerometer g-range

Register 0x25 (INT_3)

Contains the delay time definition for the high-g interrupt.

Name	0x25	INT_3		
Bit	7	6	5	4
Read/Write	R/W	R/W	R/W	R/W
Reset Value	0	0	0	0
Content	high_dur<7:4>			
Bit	3	2	1	0
Read/Write	R/W	R/W	R/W	R/W
Reset Value	1	1	1	1
Content	high_dur<3:0>			

high_dur<7:0>: high-g interrupt trigger delay according to $[high_dur<7:0> + 1] \cdot 2$ ms in a range from 2 ms to 512 ms; the default corresponds to a delay of 32 ms.

Register 0x26 (INT_4)

Contains the threshold definition for the high-g interrupt.

Name	0x26	INT_4		
Bit	7	6	5	4
Read/Write	R/W	R/W	R/W	R/W
Reset Value	1	1	0	0
Content	high_th<7:4>			
Bit	3	2	1	0
Read/Write	R/W	R/W	R/W	R/W
Reset Value	0	0	0	0
Content	high_th<3:0>			

high_th<7:0>: threshold of high-g interrupt according to $high_th<7:0> \cdot 7.81$ mg (2-g range), $high_th<7:0> \cdot 15.63$ mg (4-g range), $high_th<7:0> \cdot 31.25$ mg (8-g range), or $high_th<7:0> \cdot 62.5$ mg (16-g range)

Register 0x27 (INT_5)

Contains the definition of the number of samples to be evaluated for the slope interrupt (any-motion detection) and the slow/no-motion interrupt trigger delay.

Name	0x27	INT_5		
Bit	7	6	5	4
Read/Write	R/W	R/W	R/W	R/W
Reset Value	0	0	0	0
Content	slo_no_mot_dur<5:2>			
Bit	3	2	1	0
Read/Write	R/W	R/W	R/W	R/W
Reset Value	0	0	0	0
Content	slo_no_mot_dur<1:0>		slope_dur<1:0>	

slo_no_mot_dur<5:0>: Function depends on whether the slow-motion or no-motion interrupt function has been selected. If the slow-motion interrupt function has been enabled (slo_no_mot_sel = '0') then [slo_no_mot_dur<1:0>+1] consecutive slope data points must be above the slow/no-motion threshold (slo_no_mot_th) for the slow-/no-motion interrupt to trigger. If the no-motion interrupt function has been enabled (slo_no_mot_sel = '1') then slo_no_motion_dur<5:0> defines the time for which no slope data points must exceed the slow/no-motion threshold (slo_no_mot_th) for the slow/no-motion interrupt to trigger. The delay time in seconds may be calculated according with the following equation:

$$\begin{aligned} \text{slo_no_mot_dur}\langle 5:4 \rangle = 'b00' &\rightarrow [\text{slo_no_mot_dur}\langle 3:0 \rangle + 1] \\ \text{slo_no_mot_dur}\langle 5:4 \rangle = 'b01' &\rightarrow [\text{slo_no_mot_dur}\langle 3:0 \rangle \cdot 4 + 20] \\ \text{slo_no_mot_dur}\langle 5 \rangle = '1' &\rightarrow [\text{slo_no_mot_dur}\langle 4:0 \rangle \cdot 8 + 88] \end{aligned}$$

slope_dur<1:0>: slope interrupt triggers if [slope_dur<1:0>+1] consecutive slope data points are above the slope interrupt threshold slope_th<7:0>

Register 0x28 (INT_6)

Contains the threshold definition for the any-motion interrupt.

Name	0x28	INT_6		
Bit	7	6	5	4
Read/Write	R/W	R/W	R/W	R/W
Reset Value	0	0	0	1
Content	slope_th<7:4>			
Bit	3	2	1	0
Read/Write	R/W	R/W	R/W	R/W
Reset Value	0	1	0	0
Content	slope_th<3:0>			

slope_th<7:0>: Threshold of the any-motion interrupt. It is range-dependent and defined as a sample-to-sample difference according to
 slope_th<7:0> · 3.91 mg (2-g range) /
 slope_th<7:0> · 7.81 mg (4-g range) /
 slope_th<7:0> · 15.63 mg (8-g range) /
 slope_th<7:0> · 31.25 mg (16-g range)

Register 0x29 (INT_7)

Contains the threshold definition for the slow/no-motion interrupt.

Name	0x29	INT_7		
Bit	7	6	5	4
Read/Write	R/W	R/W	R/W	R/W
Reset Value	0	0	0	1
Content	slo_no_mot_th<7:4>			
Bit	3	2	1	0
Read/Write	R/W	R/W	R/W	R/W
Reset Value	0	1	0	0
Content	slo_no_mot_th<3:0>			

slo_no_mot_th<7:0>: Threshold of slow/no-motion interrupt. It is range-dependent and defined as a sample-to-sample difference according to
 slo_no_mot_th<7:0> · 3.91 mg (2-g range),
 slo_no_mot_th<7:0> · 7.81 mg (4-g range),
 slo_no_mot_th<7:0> · 15.63 mg (8-g range),
 slo_no_mot_th<7:0> · 31.25 mg (16-g range)

Register 0x2A (INT_8)

Contains the timing definitions for the single tap and double tap interrupts.

Name	0x2A	INT_8		
Bit	7	6	5	4
Read/Write	R/W	R/W	R/W	R/W
Reset Value	0	0	0	0
Content	tap_quiet	tap_shock	reserved	reserved
Bit	3	2	1	0
Read/Write	R/W	R/W	R/W	R/W
Reset Value	0	1	0	0
Content	reserved	tap_dur<2:0>		

tap_quiet:	selects a tap quiet duration of '0' → 30 ms, '1' → 20 ms
tap_shock:	selects a tap shock duration of '0' → 50 ms, '1' → 75 ms
reserved:	write '0'
tap_dur<2:0>:	selects the length of the time window for the second shock event for double tap detection according to '000b' → 50 ms, '001b' → 100 ms, '010b' → 150 ms, '011b' → 200 ms, '100b' → 250 ms, '101b' → 375 ms, '110b' → 500 ms, '111b' → 700 ms.

Register 0x2B (INT_9)

Contains the definition of the number of samples processed by the single / double-tap interrupt engine after wake-up in low-power mode. It also defines the threshold definition for the single and double tap interrupts.

Name	0x2B	INT_9		
Bit	7	6	5	4
Read/Write	R/W	R/W	R/W	R/W
Reset Value	0	0	0	0
Content	tap_samp<1:0>		reserved	tap_th<4>
Bit	3	2	1	0
Read/Write	R/W	R/W	R/W	R/W
Reset Value	1	0	1	0
Content	tap_th<3:0>			

tap_samp<1:0>: selects the number of samples that are processed after wake-up in the low-power mode according to '00b' → 2 samples, '01b' → 4 samples, '10b' → 8 samples, and '11b' → 16 samples

reserved: write '0'

tap_th<4:0>: threshold of the single/double-tap interrupt corresponding to an acceleration difference of tap_th<4:0> · 62.5mg (2g-range), tap_th<4:0> · 125mg (4g-range), tap_th<4:0> · 250mg (8g-range), and tap_th<4:0> · 500mg (16g-range).

Register 0x2C (INT_A)

Contains the definition of hysteresis, blocking, and mode for the orientation interrupt

Name	0x2C	INT_A		
Bit	7	6	5	4
Read/Write	R/W	R/W	R/W	R/W
Reset Value	0	0	0	1
Content	reserved	orient_hyst<2:0>		
Bit	3	2	1	0
Read/Write	R/W	R/W	R/W	R/W
Reset Value	1	0	0	0
Content	orient_blocking<1:0>		orient_mode<1:0>	

reserved: write '0'

orient_hyst<2:0>: sets the hysteresis of the orientation interrupt; 1 LSB corresponds to 62.5 mg irrespective of the selected g-range

orient_blocking<1:0>: selects the blocking mode that is used for the generation of the orientation interrupt. The following blocking modes are available:

'00b' → no blocking,

'01b' → theta blocking or acceleration in any axis > 1.5g,

'10b' → theta blocking or acceleration slope in any axis > 0.2 g or acceleration in any axis > 1.5g

'11b' → theta blocking or acceleration slope in any axis > 0.4 g or acceleration in any axis > 1.5g and value of orient is not stable for at least 100ms

orient_mode<1:0>: sets the thresholds for switching between the different orientations. The settings: '00b' → symmetrical, '01b' → high-asymmetrical, '10b' → low-asymmetrical, '11b' → symmetrical.

Register 0x2D (INT_B)

Contains the definition of the axis orientation, up/down masking, and the theta blocking angle for the orientation interrupt.

Name	0x2D	INT_B		
Bit	7	6	5	4
Read/Write	R/W	R/W	R/W	R/W
Reset Value	n/a	1	0	0
Content	reserved	orient_ud_en	orient_theta<5:4>	
Bit	3	2	1	0
Read/Write	R/W	R/W	R/W	R/W
Reset Value	1	0	0	0
Content	orient_theta<3:0>			

orient_ud_en: change of up/down-bit '1' → generates an orientation interrupt, '0' → is ignored and will not generate an orientation interrupt

orient_theta<5:0>: defines a blocking angle between 0° and 44.8°

Register 0x2E (INT_C)

Contains the definition of the flat threshold angle for the flat interrupt.

Name	0x2E	INT_C		
Bit	7	6	5	4
Read/Write	R/W	R/W	R/W	R/W
Reset Value	n/a	n/a	0	0
Content	reserved	flat_theta<5:4>		
Bit	3	2	1	0
Read/Write	R/W	R/W	R/W	R/W
Reset Value	1	0	0	0
Content	flat_theta<3:0>			

reserved: write '0'

flat_theta<5:0>: defines threshold for detection of flat position in range from 0° to 44.8°.

Register 0x2F (INT_D)

Contains the definition of the flat interrupt hold time and flat interrupt hysteresis.

Name	0x2F	INT_D		
Bit	7	6	5	4
Read/Write	R/W	R/W	R/W	R/W
Reset Value	0	0	0	1
Content	reserved		flat_hold_time<1:0>	
Bit	3	2	1	0
Read/Write	R/W	R/W	R/W	R/W
Reset Value	0	0	0	1
Content	reserved	flat_hy<2:0>		

reserved: write '0'

flat_hold_time<1:0>: delay time for which the flat value must remain stable for the flat interrupt to be generated: '00b' → 0 ms, '01b' → 512 ms, '10b' → 1024 ms, '11b' → 2048 ms

flat_hy<2:0>: defines flat interrupt hysteresis; flat value must change by more than twice the value of flat interrupt hysteresis to detect a state change. For details see chapter 4.7.8.

'000b' → hysteresis of the flat detection disabled

6.12 Self-test

Register 0x32 (PMU_SELF_TEST)

Contains the settings for the sensor self-test configuration and trigger.

Name	0x32	PMU_SELF_TEST		
Bit	7	6	5	4
Read/Write	R/W	R/W	R/W	R/W
Reset Value	0	0	0	0
Content	reserved			self_test_amp
Bit	3	2	1	0
Read/Write	R/W	R/W	R/W	R/W
Reset Value	0	0	0	0
Content	reserved_0	self_test_sign	self_test-axis<1:0>	

reserved: write '0x0'

reserved_0: write '0x0'

self_test_amp; select amplitude of the selftest deflection '1' → high, default value is low ('0')

self_test_sign: select sign of self-test excitation as '1' → positive, or '0' → negative

self_test_axis: select axis to be self-tested: '00b' → self-test disabled, '01b' → x-axis, '10b' → y-axis, or '11b' → z-axis; when a self-test is performed, only the acceleration data readout value of the selected axis is valid; after the self-test has been enabled a delay of a least 50 ms is necessary for the read-out value to settle

6.13 Non-volatile memory control (EEPROM)

Register 0x33 (TRIM_NVM_CTRL)

Contains the control settings for the few-time programmable non-volatile memory (NVM).

Name	0x33	TRIM_NVM_CTRL		
Bit	7	6	5	4
Read/Write	R	R	R	R
Reset Value	n/a	n/a	n/a	n/a
Content	nvm_remain<3:0>			
Bit	3	2	1	0
Read/Write	R/W	R	W	R/W
Reset Value	0	n/a	0	0
Content	nvm_load	nvm_rdy	nvm_prog_trig	nvm_prog_mode

- nvm_remain<3:0>: number of remaining write cycles permitted for NVM; the number is decremented each time a write to the NVM is triggered
- nvm_load: '1' → trigger, or '0' → do not trigger an update of all configuration registers from NVM; the nvm_rdy flag must be '1' prior to triggering the update
- nvm_rdy: status of NVM controller: '0' → NVM write / NVM update operation is in progress, '1' → NVM is ready to accept a new write or update trigger
- nvm_prog_trig: '1' → trigger, or '0' → do not trigger an NVM write operation; the trigger is only accepted if the NVM was unlocked before and nvm_remain<3:0> is greater than '0'; flag nvm_rdy must be '1' prior to triggering the write cycle
- nvm_prog_mode: '1' → unlock, or '0' → lock NVM write operation

6.14 Interface configuration

Register 0x34 (BGW_SPI3_WDT)

Contains settings for the digital interfaces.

Name	0x34	BGW_SPI3_WDT			
Bit	7	6	5	4	
Read/Write	R/W	R/W	R/W	R/W	
Reset Value	0	0	0	0	
Content	Reserved				
Bit	3	2	1	0	
Read/Write	R/W	R/W	R/W	R/W	
Reset Value	0	0	0	0	
Content	reserved	i2c_wdt_en	i2c_wdt_sel	spi3	

reserved: write '0'

i2c_wdt_en: if I²C interface mode is selected then '1' → enable, or '0' → disables the watchdog at the SDI pin (= SDA for I²C)

i2c_wdt_sel: select an I²C watchdog timer period of '0' → 1 ms, or '1' → 50 ms

spi3: select '0' → 4-wire SPI, or '1' → 3-wire SPI mode

6.15 Offset compensation

Register 0x36 (OFC_CTRL)

Contains control signals and configuration settings for the fast and the slow offset compensation.

Name	0x36	OFC_CTRL		
Bit	7	6	5	4
Read/Write	W	W	W	R
Reset Value	0	0	0	0
Content	offset_reset	cal_trigger<1:0>		cal_rdy
Bit	3	2	1	0
Read/Write	R/W	R/W	R/W	R/W
Reset Value	0	0	0	0
Content	reserved	hp_z_en	hp_y_en	hp_x_en

offset_reset: '1' → set all offset compensation registers (0x38 to 0x3A) to zero, or '0' → keep their values

offset_trigger<1:0>: trigger fast compensation for '01b' → x-axis, '10b' → y-axis, or '11b' → z-axis; '00b' → do not trigger offset compensation; offset compensation must not be triggered when cal_rdy is '0'

cal_rdy: indicates the state of the fast compensation: '0' → offset compensation is in progress, or '1' → offset compensation is ready to be retriggered

reserved: write '0'

hp_z_en: '1' → enable, or '0' → disable slow offset compensation for the z-axis

hp_y_en: '1' → enable, or '0' → disable slow offset compensation for the y-axis

hp_x_en: '1' → enable, or '0' → disable slow offset compensation for the x-axis

Register 0x37 (OFC_SETTING)

Contains configuration settings for the fast and the slow offset compensation.

Name	0x37	OFC_SETTING		
Bit	7	6	5	4
Read/Write	R/W	R/W	R/W	R/W
Reset Value	0	0	0	0
Content	reserved	offset_target_z<1:0>		offset_target_y<1>
Bit	3	2	1	0
Read/Write	R/W	R/W	R/W	R/W
Reset Value	0	0	0	0
Content	offset_target_y<0 >	offset_target_x<1:0>		cut_off

reserved: write '0'

offset_target_z<1:0>: offset compensation target value for z-axis is '00b' → 0 g, '01b' → +1 g, '10b' → -1 g, or '11b' → 0 g

offset_target_y<1:0>: offset compensation target value for y-axis is '00b' → 0 g, '01b' → +1 g, '10b' → -1 g, or '11b' → 0 g

offset_target_x<1:0>: offset compensation target value for x-axis is '00b' → 0 g, '01b' → +1 g, '10b' → -1 g, or '11b' → 0 g

cut_off:

(0x37) cut_off	high-pass filter bandwidth	Example bw = 500 Hz
0b	$\frac{1\text{Hz} \times bw}{1000\text{ Hz}}$	$\frac{1\text{Hz} \times 500\text{ Hz}}{1000\text{ Hz}} = 0.5\text{ Hz}$
1b	$\frac{10\text{Hz} \times bw}{1000\text{ Hz}}$	$\frac{10\text{Hz} \times 500\text{ Hz}}{1000\text{ Hz}} = 5\text{ Hz}$

*bw: please insert selected decimal data bandwidth value [Hz] from table 8

Register 0x38 (OFC_OFFSET_X)

Contains the offset compensation value for x-axis acceleration readout data.

Name	0x38	OFC_OFFSET_X		
Bit	7	6	5	4
Read/Write	R/W	R/W	R/W	R/W
Reset Value	0	0	0	0
Content	offset_x<7:4>			
Bit	3	2	1	0
Read/Write	R/W	R/W	R/W	R/W
Reset Value	0	0	0	0
Content	offset_x<3:0>			

offset_x<7:0>: offset value, which is subtracted from the internal filtered and unfiltered x-axis acceleration data; the offset value is represented with two's complement notation, with a mapping of +127 → +0.992g, 0 → 0 g, and -128 → -1 g; the scaling is independent of the selected g-range; the content of the offset_x<7:0> may be written to the NVM; it is automatically restored from the NVM after each power-on or softreset; offset_x<7:0> may be written directly by the user; it is generated automatically after triggering the fast offset compensation procedure for the x-axis

Register 0x39 (OFC_OFFSET_Y)

Contains the offset compensation value for y-axis acceleration readout data.

Name	0x39	OFC_OFFSET_Y		
Bit	7	6	5	4
Read/Write	R/W	R/W	R/W	R/W
Reset Value	0	0	0	0
Content	offset_y<7:4>			
Bit	3	2	1	0
Read/Write	R/W	R/W	R/W	R/W
Reset Value	0	0	0	0
Content	offset_y<3:0>			

offset_y<7:0>: offset value, which is subtracted from the internal filtered and unfiltered y-axis acceleration data; the offset value is represented with two's complement notation, with a mapping of +127 → +0.992g, 0 → 0 g, and -128 → -1 g; the scaling is independent of the selected g-range; the content of the offset_y<7:0> may be written to the NVM; it is automatically restored from the NVM after each power-on or softreset; offset_y<7:0> may be written directly by the user; it is generated automatically after triggering the fast offset compensation procedure for the y-axis

Register 0x3A (OFC_OFFSET_Z)

Contains the offset compensation value for z-axis acceleration readout data.

Name	0x3A	OFC_OFFSET_Z		
Bit	7	6	5	4
Read/Write	R/W	R/W	R/W	R/W
Reset Value	0	0	0	0
Content	offset_z<7:4>			
Bit	3	2	1	0
Read/Write	R/W	R/W	R/W	R/W
Reset Value	0	0	0	0
Content	offset_z<3:0>			

offset_z<7:0>: offset value, which is subtracted from the internal filtered and unfiltered z-axis acceleration data; the offset value is represented with two's complement notation, with a mapping of +127 → +0.992g, 0 → 0 g, and -128 → -1 g; the scaling is independent of the selected g-range; the content of the offset_z<7:0> may be written to the NVM; it is automatically restored from the NVM after each power-on or softreset; offset_z<7:0> may be written directly by the user; it is generated automatically after triggering the fast offset compensation procedure for the z-axis

6.16 Non-volatile memory back-up

Register 0x3B (TRIM_GP0)

Contains general purpose data register with NVM back-up.

Name	0x3B	TRIM_GP0			
Bit	7	6	5	4	
Read/Write	R/W	R/W	R/W	R/W	
Reset Value	0	0	0	0	
Content	GP0<7:4>				
Bit	3	2	1	0	
Read/Write	R/W	R/W	R/W	R/W	
Reset Value	0	0	0	0	
Content	GP0<3:0>				

GP0<7:0>: general purpose NVM image register not linked to any sensor-specific functionality; register may be written to NVM and is restored after each power-up or softreset

Register 0x3C (TRIM_GP1)

Contains general purpose data register with NVM back-up.

Name	0x3C	TRIM_GP1			
Bit	7	6	5	4	
Read/Write	R/W	R/W	R/W	R/W	
Reset Value	0	0	0	0	
Content	GP1<7:4>				
Bit	3	2	1	0	
Read/Write	R/W	R/W	R/W	R/W	
Reset Value	0	0	0	0	
Content	GP1<3:0>				

GP1<7:0>: general purpose NVM image register not linked to any sensor-specific functionality; register may be written to NVM and is restored after each power-up or softreset

6.17 FIFO configuration and FIFO data

Register 0x30 (FIFO_CONFIG_0)

Contains the FIFO watermark level.

Name	0x30	FIFO_CONFIG_0		
Bit	7	6	5	4
Read/Write	R/W	R/W	R/W	R/W
Reset Value	n/a	n/a	0	0
Content	Reserved		fifo_water_mark_level_trigger_retain<5:4>	
Bit	3	2	1	0
Read/Write	R/W	R/W	R/W	R/W
Reset Value	0	0	0	0
Content	fifo_water_mark_level_trigger_retain<3:0>			

reserved: write '0'

fifo_water_mark_level_trigger_retain<5:0>:

fifo_water_mark_level_trigger_retain<5:0> defines the FIFO watermark level. An interrupt will be generated, when the number of entries in the FIFO is equal to fifo_water_mark_level_trigger_retain<5:0>;

Register 0x3E (FIFO_CONFIG_1)

Contains FIFO configuration settings. The FIFO buffer memory is cleared and the fifo-full flag is cleared when writing to FIFO_CONFIG_1 register.

Name	0x3E	FIFO_CONFIG_1		
Bit	7	6	5	4
Read/Write	R/W	R/W	R/W	R/W
Reset Value	0	0	0	0
Content	fifo_mode<1:0>		Reserved	
Bit	3	2	1	0
Read/Write	R/W	R/W	R/W	R/W
Reset Value	0	0	0	0
Content	Reserved		fifo_data_select<1:0>	

fifo_mode<1:0>: selects the FIFO operating mode:

'00b' → BYPASS (buffer depth of 1 frame; old data is discarded),
 '01b' → FIFO (data collection stops when buffer is filled with 32 frames),
 '10b' → STREAM (sampling continues when buffer is full; old is discarded),
 '11b' → reserved, do not use

fifo_data_select<1:0>: selects whether '00b' → X+Y+Z, '01b' → X only, '10b' → Y only, '11b' → Z only acceleration data are stored in the FIFO.

Register 0x3F (FIFO_DATA)

FIFO data readout register. The format of the LSB and MSB components corresponds to that of the acceleration data readout registers. The new data flag is preserved. Read burst access may be used since the address counter will not increment when the read burst is started at the address of FIFO_DATA. The entire frame is discarded when a frame is only partially read out.

Name	0x3F	FIFO_DATA		
Bit	7	6	5	4
Read/Write	R	R	R	R
Reset Value	n/a	n/a	n/a	n/a
Content	fifo_data_output_register<7:4>			
Bit	3	2	1	0
Read/Write	R	R	R	R
Reset Value	n/a	n/a	n/a	n/a
Content	fifo_data_output_register<3:0>			

fifo_data_output_register<7:0>: FIFO data readout; data format depends on the setting of register fifo_data_select<1:0>:

if X+Y+Z data are selected, the data of frame n is reading out in the order of X-lsb(n), X-msb(n), Y-lsb(n), Y-msb(n), Z-lsb(n), Z-msb(n);

if X-only is selected, the data of frame n and n+1 are reading out in the order of X-lsb(n), X-msb(n), X-lsb(n+1), X-msb(n+1); the Y-only and Z-only modes behave analogously

7. Magnetometer register description

7.1 General remarks

The entire communication with the device's magnetometer part is performed by reading from and writing to registers. Registers have a width of 8 bits; they are mapped to a common space of 50 addresses from (0x40) up to (0x71). Within the used range there are several registers which are marked as 'reserved'. Any reserved bit is ignored when it is written and no specific value is guaranteed when read. Especially, in SPI mode the SDO pin may stay in high-Z state when reading some of these registers.

Registers with addresses from (0x40) up to (0x4A) are read-only. Any attempt to write to these registers is ignored.

7.2 Register map

Register Address	Default Value	bit7	bit6	bit5	bit4	bit3	bit2	bit1	bit0
0x71	N/A								
0x70	N/A								
0x6F	N/A								
0x6E	N/A								
0x6D	N/A								
0x6C	N/A								
0x6B	N/A								
0x6A	N/A								
0x69	N/A								
0x68	N/A								
0x67	N/A								
0x66	N/A								
0x65	N/A								
0x64	N/A								
0x63	N/A								
0x62	N/A								
0x61	N/A								
0x60	N/A								
0x5F	N/A								
0x5E	N/A								
0x5D	N/A								
0x5C	N/A								
0x5B	N/A								
0x5A	N/A								
0x59	N/A								
0x58	N/A								
0x57	N/A								
0x56	N/A								
0x55	N/A								
0x54	N/A								
0x53	N/A								
0x52	0x00	REPZ Number Of Repetitions (valid for Z) [7:0]							
0x51	0x00	REPLY Number Of Repetitions (valid for XY) [7:0]							
0x50	0x00								
0x4F	0x00								
0x4E	0x07	Data Ready Pin En		Channel Z	Channel Y	Channel X	DR Polarity		
0x4D	0x3F	Data Overrun En	Overflow Int En						
0x4C	0x06	Adv. ST [1:0]			Data Rate [2:0]		Opmode [1:0]	Self Test	
0x4B	0x01	Soft Reset *1	fixed '0'	fixed '0'	fixed '0'	fixed '0'	SP13en	Soft Reset *1	Power Control Bit
0x4A	0x00	Data Overrun	Overflow						
0x49	N/A				RHALL [5:0] LSB	RHALL [13:6] MSB		fixed '0'	Data Ready Status
0x48	N/A								
0x47	N/A					DATA Z [14:7] MSB			
0x46	N/A					DATA Z [6:0] LSB			Z-Self-Test
0x45	N/A					DATA Y [12:5] MSB			
0x44	N/A				DATA Y [4:0] LSB		fixed '0'	fixed '0'	Y-Self-Test
0x43	N/A					DATA X [12:5] MSB			
0x42	N/A				DATA X [4:0] LSB		fixed '0'	fixed '0'	X-Self-Test
0x41	N/A								
0x40	0x32	Chip ID = 0x32 (can only be read if power control bit = "1")							

	w/r
	w/r accessible in suspend mode
	read only
	reserved

7.3 Chip ID

Register (0x40) Chip ID contains the magnetometer chip identification number, which is 0x32. This number can only be read if the power control bit (register 0x4B bit0) is enabled.

Table 25: Chip identification number, register (0x40)

Bit 7	Bit 6	Bit 5	Bit 4	Bit 3	Bit 2	Bit 1	Bit 0
0	0	1	1	0	0	1	0

Register (0x41) is reserved

7.4 Magnetic field data

Register (0x42) contains the LSB part of x-axis magnetic field data and the self-test result flag for the x-axis.

Table 26: LSB part of x-axis magnetic field, register (0x42)

(0x42) Bit	Name	Description
Bit 7	DATAX_lsb <4>	Bit 4 of x-axis magnetic field data
Bit 6	DATAX_lsb <3>	Bit 3 of x-axis magnetic field data
Bit 5	DATAX_lsb <2>	Bit 2 of x-axis magnetic field data
Bit 4	DATAX_lsb <1>	Bit 1 of x-axis magnetic field data
Bit 3	DATAX_lsb <0>	Bit 0 of x-axis magnetic field data = x LSB
Bit 2	-	(fixed to 0)
Bit 1	-	(fixed to 0)
Bit 0	SelfTestX	Self-test result flag for x-axis, default is "1"

Register (0x43) contains the MSB part of x-axis magnetic field data.

Table 27: MSB part of x-axis magnetic field, register (0x43)

(0x43) Bit	Name	Description
Bit 7	DATAX_msb <12>	Bit 12 of x-axis magnetic field data = x MSB
Bit 6	DATAX_msb <11>	Bit 11 of x-axis magnetic field data
Bit 5	DATAX_msb <10>	Bit 10 of x-axis magnetic field data
Bit 4	DATAX_msb <9>	Bit 9 of x-axis magnetic field data
Bit 3	DATAX_msb <8>	Bit 8 of x-axis magnetic field data
Bit 2	DATAX_msb <7>	Bit 7 of x-axis magnetic field data
Bit 1	DATAX_msb <6>	Bit 6 of x-axis magnetic field data
Bit 0	DATAX_msb <5>	Bit 5 of x-axis magnetic field data

Register (0x44) contains the LSB part of y-axis magnetic field data and the self-test result flag for the y-axis.

Table 28: LSB part of y-axis magnetic field, register (0x44)

(0x44) Bit	Name	Description
Bit 7	DATAY_lsb <4>	Bit 4 of y-axis magnetic field data
Bit 6	DATAY_lsb <3>	Bit 3 of y-axis magnetic field data
Bit 5	DATAY_lsb <2>	Bit 2 of y-axis magnetic field data
Bit 4	DATAY_lsb <1>	Bit 1 of y-axis magnetic field data
Bit 3	DATAY_lsb <0>	Bit 0 of y-axis magnetic field data = y LSB
Bit 2	-	(fixed to 0)
Bit 1	-	(fixed to 0)
Bit 0	SelfTestY	Self-test result flag for y-axis, default is "1"

Register (0x45) contains the MSB part of y-axis magnetic field data.

Table 29: MSB part of y-axis magnetic field, register (0x45)

(0x45) Bit	Name	Description
Bit 7	DATAY_msb <12>	Bit 12 of y-axis magnetic field data = y MSB
Bit 6	DATAY_msb <11>	Bit 11 of y-axis magnetic field data
Bit 5	DATAY_msb <10>	Bit 10 of y-axis magnetic field data
Bit 4	DATAY_msb <9>	Bit 9 of y-axis magnetic field data
Bit 3	DATAY_msb <8>	Bit 8 of y-axis magnetic field data
Bit 2	DATAY_msb <7>	Bit 7 of y-axis magnetic field data
Bit 1	DATAY_msb <6>	Bit 6 of y-axis magnetic field data
Bit 0	DATAY_msb <5>	Bit 5 of y-axis magnetic field data

Register (0x46) contains the LSB part of z-axis magnetic field data and the self-test result flag for the z-axis.

Table 30: LSB part of z-axis magnetic field, register (0x46)

(0x46) Bit	Name	Description
Bit 7	DATAZ_lsb <6>	Bit 6 of z-axis magnetic field data
Bit 6	DATAZ_lsb <5>	Bit 5 of z-axis magnetic field data
Bit 5	DATAZ_lsb <4>	Bit 4 of z-axis magnetic field data
Bit 4	DATAZ_lsb <3>	Bit 3 of z-axis magnetic field data
Bit 3	DATAZ_lsb <2>	Bit 2 of z-axis magnetic field data
Bit 2	DATAZ_lsb <1>	Bit 1 of z-axis magnetic field data
Bit 1	DATAZ_lsb <0>	Bit 0 of z-axis magnetic field data = z LSB
Bit 0	SelfTestZ	Self-test result flag for z-axis, default is "1"

Register (0x47) contains the MSB part of z-axis magnetic field data.

Table 31: MSB part of z-axis magnetic field, register (0x47)

(0x47) Bit	Name	Description
Bit 7	DATAZ_msb <14>	Bit 14 of y-axis magnetic field data = z MSB
Bit 6	DATAZ_msb <13>	Bit 13 of y-axis magnetic field data
Bit 5	DATAZ_msb <12>	Bit 12 of y-axis magnetic field data
Bit 4	DATAZ_msb <11>	Bit 11 of y-axis magnetic field data
Bit 3	DATAZ_msb <10>	Bit 10 of y-axis magnetic field data
Bit 2	DATAZ_msb <9>	Bit 9 of y-axis magnetic field data
Bit 1	DATAZ_msb <8>	Bit 8 of y-axis magnetic field data
Bit 0	DATAZ_msb <7>	Bit 7 of y-axis magnetic field data

Register (0x48) contains the LSB part of hall resistance and the Data Ready (DRDY) status bit.

Table 32: LSB part of hall resistance, register (0x48)

(0x48) Bit	Name	Description
Bit 7	RHALL_lsb <5>	Bit 5 of hall resistance
Bit 6	RHALL_lsb <4>	Bit 4 of hall resistance
Bit 5	RHALL_lsb <3>	Bit 3 of hall resistance
Bit 4	RHALL_lsb <2>	Bit 2 of hall resistance
Bit 3	RHALL_lsb <1>	Bit 1 of hall resistance
Bit 2	RHALL_lsb <0>	Bit 0 of hall resistance = RHALL LSB
Bit 1	-	(fixed to 0)
Bit 0	Data Ready Status	Data ready (DRDY) status bit

Register (0x49) contains the MSB part of hall resistance.

Table 33: MSB part of hall resistance, register (0x49)

(0x49) Bit	Name	Description
Bit 7	RHALL_msb <13>	Bit 13 of hall resistance = RHALL MSB
Bit 6	RHALL_msb <12>	Bit 12 of hall resistance
Bit 5	RHALL_msb <11>	Bit 11 of hall resistance
Bit 4	RHALL_msb <10>	Bit 10 of hall resistance
Bit 3	RHALL_msb <9>	Bit 9 of hall resistance
Bit 2	RHALL_msb <8>	Bit 8 of hall resistance
Bit 1	RHALL_msb <7>	Bit 7 of hall resistance
Bit 0	RHALL_msb <6>	Bit 6 of hall resistance

7.5 Interrupt status register

Register (0x4A) contains the states of all magnetometer interrupts.

Table 34: Interrupt status, register (0x4A)

(0x4A) Bit	Name	Description
Bit 7	Data overrun	Data overrun status flag
Bit 6	Overflow	Overflow status flag
Bit 5	reserved	
Bit 4	reserved	
Bit 3	reserved	
Bit 2	reserved	
Bit 1	reserved	
Bit 0	reserved	

7.6 Power and operation modes, self-test and data output rate control registers

Register (0x4B) contains control bits for power control, soft reset and interface SPI mode selection. This special control register is also accessible in suspend mode.

Soft reset is executed when both bits (register 0x4B bit7 and bit1) are set “1”. Soft reset does not execute a full POR sequence, but all registers are reset except for the “trim” registers above register 0x54 and the power control register (0x4B). Soft reset always brings the device into sleep mode. When device is in the suspend mode, soft reset is ignored and the device remains in suspend mode. The two “Soft Reset” bits are reset to “0” automatically after soft reset was completed. To perform a full POR reset, bring the device into suspend and then back into sleep mode.

When SPI mode is selected, the “SPI3En” bit enables SPI 3-wire mode when set “1”. When “SPI3En” is set “0” (default), 4-wire SPI mode is selected.

Setting the “Power Control bit” to “1” brings the device up from Suspend mode to Sleep mode, when “Power Control bit” is set “0” the device returns to Suspend mode (see chapter 4.2.2 for details of magnetometer power modes).

Table 35: Power control, soft reset and SPI mode control register (0x4B)

(0x4B) Bit	Name	Description
Bit 7	Soft Reset ‘1’	One of the soft reset trigger bits.
Bit 6	-	(fixed to 0)
Bit 5	-	(fixed to 0)
Bit 4	-	(fixed to 0)
Bit 3	-	(fixed to 0)
Bit 2	SPI3en	Enable bit for SPI3 mode
Bit 1	Soft Reset ‘1’	One of the soft reset trigger bits.
Bit 0	Power Control bit	When set to “0”, suspend mode is selected

Register (0x4C) contains control bits for operation mode, output data rate and self-test.

The two “Adv. ST” bits control the on-chip advanced self-test (see chapter 4.4.2 for details of the magnetometer advanced self-test).

The three “Data rate” bits control the magnetometer output data rate according to below Table 37.

The two “Opmode” bits control the operation mode according to below Table 38 (see chapter 4.2.2 for a detailed description of magnetometer power modes).

Table 36: Operation mode, output data rate and self-test control register (0x4C)

(0x4C) Bit	Name	Description
Bit 7	Adv. ST <1>	Advanced self-test control bit 1
Bit 6	Adv. ST <0>	Advanced self-test control bit 0
Bit 5	Data rate <2>	Data rate control bit 2
Bit 4	Data rate <1>	Data rate control bit 1
Bit 3	Data rate <0>	Data rate control bit 0
Bit 2	Opmode <1>	Operation mode control bit 1
Bit 1	Opmode <0>	Operation mode control bit 0
Bit 0	Self Test	Normal self-test control bit

Three “Data rate” bits control the output data rate (ODR) of the BMC156 magnetometer part:

Table 37: Output data rate (ODR) setting (0x4C)

(0x4C) Data rate <2:0>	Magnetometer output data rate (ODR) [Hz]
000b	10 (default)
001b	2
010b	6
011b	8
100b	15
101b	20
110b	25
111b	30

Two “Opmode” bits control the operation mode of the BMC156 magnetometer part:

Table 38: Operation mode setting (0x4C)

(0x4C) Opmode <1:0>	Magnetometer operation mode ⁸
00b	Normal mode
01b	Forced mode
10b	Reserved, do not use
11b	Sleep Mode

⁸ See chapter 4.2.2 for a detailed description of magnetometer power modes.

Register (0x4E) contains control bits to enable data ready interrupt, to change data ready pin polarity and axes enable bits. If a magnetic measurement channel is disabled, its last measured magnetic output values will remain in the data registers. If the Z channel is disabled, the resistance measurement will also be disabled and the resistance output value will be set to zero.

Table 39: Interrupt settings and axes enable bits control register (0x4E)

(0x4E) Bit	Name	Description
Bit 7	Data Ready Pin En	Enables data ready status mapping on DRDY pin (active high, default is "0" disabled)
Bit 6	reserved	
Bit 5	Channel Z	Enable z-axis and resistance measurement (active low, default is "0" enabled)
Bit 4	Channel Y	Enable y-axis (active low, default is "0" enabled)
Bit 3	Channel X	Enable x-axis (active low, default is "0" enabled)
Bit 2	DR Polarity	Data ready (DRDY) pin polarity ("0" is active low, "1" is active high, default is "1" active high)
Bit 1	reserved	
Bit 0	reserved	

7.7 Number of repetitions control registers

Register (0x51) contains the number of repetitions for x/y-axis. Table 41 below shows the number of repetitions resulting out of the register configuration. The performed number of repetitions n_{XY} can be calculated from unsigned register value as $n_{XY} = 1 + 2 \cdot \text{REP}_{XY}$ as shown below, where b7-b0 are the bits 7 to 0 of register 0x51:

$$\begin{aligned}
 n_{XY} &= 1 + 2 \cdot (b7 \cdot 2^7 + b6 \cdot 2^6 + b5 \cdot 2^5 + b4 \cdot 2^4 + b3 \cdot 2^3 + b2 \cdot 2^2 + b1 \cdot 2^1 + b0 \cdot 2^0) \\
 &= 1 + 2 \cdot (\text{REP}_{XY})
 \end{aligned}$$

Table 40: x/y-axis repetitions control register (0x51)

(0x51) Bit	Name	Description
Bit 7	REPXY <7>	Bit 7 of number of repetitions (valid for XY)
Bit 6	REPXY <6>	Bit 6 of number of repetitions (valid for XY)
Bit 5	REPXY <5>	Bit 5 of number of repetitions (valid for XY)
Bit 4	REPXY <4>	Bit 4 of number of repetitions (valid for XY)
Bit 3	REPXY <3>	Bit 3 of number of repetitions (valid for XY)
Bit 2	REPXY <2>	Bit 2 of number of repetitions (valid for XY)
Bit 1	REPXY <1>	Bit 1 of number of repetitions (valid for XY)
Bit 0	REPXY <0>	Bit 0 of number of repetitions (valid for XY)

Table 41: Numbers of repetition for x/y-axis depending on value of register (0x51)

(0x51) register value (binary)	(0x51) register value (hex)	Number of repetitions for x- and y-axis each
00000000b	0x00h	1
00000001b	0x01h	3
00000010b	0x02h	5
00000011b	0x03h	7
...		...
11111111b	0xFFh	511

Register (0x52) contains the number of repetitions for z-axis. Table 43 below shows the number of repetitions resulting out of the register configuration. The performed number of repetitions nZ can be calculated from unsigned register value as $nZ = 1 + REPZ$ as shown below, where $b7-b0$ are the bits 7 to 0 of register 0x52:

$$\begin{aligned}
 nZ &= 1 + 1 \cdot (b7 \cdot 2^7 + b6 \cdot 2^6 + b5 \cdot 2^5 + b4 \cdot 2^4 + b3 \cdot 2^3 + b2 \cdot 2^2 + b1 \cdot 2^1 + b0 \cdot 2^0) \\
 &= 1 + REPZ
 \end{aligned}$$

Table 42: Z-axis repetitions control register (0x52)

(0x52) Bit	Name	Description
Bit 7	REPZ <7>	Bit 7 of number of repetitions (valid for Z)
Bit 6	REPZ <6>	Bit 6 of number of repetitions (valid for Z)
Bit 5	REPZ <5>	Bit 5 of number of repetitions (valid for Z)
Bit 4	REPZ <4>	Bit 4 of number of repetitions (valid for Z)
Bit 3	REPZ <3>	Bit 3 of number of repetitions (valid for Z)
Bit 2	REPZ <2>	Bit 2 of number of repetitions (valid for Z)
Bit 1	REPZ <1>	Bit 1 of number of repetitions (valid for Z)
Bit 0	REPZ <0>	Bit 0 of number of repetitions (valid for Z)

Table 43: Numbers of repetition for z-axis depending on value of register (0x52)

(0x52) register value (binary)	(0x52) register value (hex)	Number of repetitions for z-axis
00000000b	0x00h	1
00000001b	0x01h	2
00000010b	0x02h	3
00000011b	0x03h	4
...		...
11111111b	0xFFh	256

8. Digital interfaces

The BMC156 supports two serial digital interface protocols for communication as a slave with a host device for each of the accelerometer and magnetometer part: SPI and I²C. Accelerometer part and magnetometer part alone operate either both in I²C mode or either both in SPI mode, mixed communication protocols are not possible because the interface pins are shared.

The active interface is selected by the state of the “protocol select” pin (PS):
 “0” (“1”) selects SPI (I²C).

By default, SPI operates in the standard 4-wire configuration. It can be re-configured by software to work in 3-wire mode instead of standard 4-wire mode for both the accelerometer part and magnetometer part.

Both interfaces share the same pins. The mapping for each interface is given in the following table:

Table 44: Mapping of the interface pins

Pin#	Name	use w/ SPI	use w/ I ² C	Description
1	SDO	SDO	Accelerometer and magnetometer part I ² C address selection	SPI: Data Output (4-wire mode) I ² C: Used to set LSB of I ² C address of accelerometer part and magnetometer part
2	SDI	SDI	SDA	SPI: Data Input (4-wire mode) Data Input / Output (3-wire mode) I ² C: Serial Data
10	CSB	CSB	Magnetometer part I ² C address selection	SPI: Chip Select for accelerometer and magnetometer part (enable) I ² C: Used to set bit1 of I ² C address of magnetometer part, always high in I ² C mode
12	SCK	SCK	SCL	SPI: Serial Clock I ² C: Serial Clock

The following table shows the electrical specifications of the interface pins:

Table 45: Electrical specification of the interface pins

Parameter	Symbol	Condition	Min	Typ	Max	Unit
Pull-up Resistance CSB in SPI mode	$R_{up,SPI}$	Internal Pull-up Resistance to VDDIO	37	55	74	$k\Omega$
Pull-up Resistance CSB in I2C mode	$R_{up,I2C}$	Internal Pull-up Resistance to VDDIO	70	120	190	$k\Omega$
Input Capacitance	C_{in}				20	pF
I ² C Bus Load Capacitance (max. drive capability)	C_{I2C_Load}				400	pF

8.1 Serial peripheral interface (SPI)

The timing specification for SPI of the BMC156 is given in the following table:

Table 46: SPI timing for BMC156 accelerometer and magnetometer part

Parameter	Symbol	Condition	Min	Max	Units
Clock Frequency	f_{SPI}	Max. Load on SDI or SDO = 25pF, $V_{DDIO} \geq 1.62V$		10	MHz
		$V_{DDIO} < 1.62V$		7.5	MHz
SCK Low Pulse	t_{SCKL}		20		ns
SCK High Pulse	t_{SCKH}		20		ns
SDI Setup Time	t_{SDI_setup}		20		ns
SDI Hold Time	t_{SDI_hold}		20		ns
SDO Output Delay	t_{SDO_OD}	Load = 25pF, $V_{DDIO} \geq 1.62V$		30	ns
		Load = 25pF, $V_{DDIO} < 1.62V$		50	ns
		Load = 250pF, $V_{DDIO} > 2.4V$		40	ns
CSB Setup Time	t_{CSB_setup}		20		ns
CSB Hold Time	t_{CSB_hold}		40		ns
Idle time between write accesses, normal mode, standby mode, low-power mode 2	$t_{IDLE_wacc_nm}$		2		μs
Idle time between write accesses, suspend mode, low-power mode 1	$t_{IDLE_wacc_sum}$		450		μs

The following figure shows the definition of the SPI timings given in Table 46:

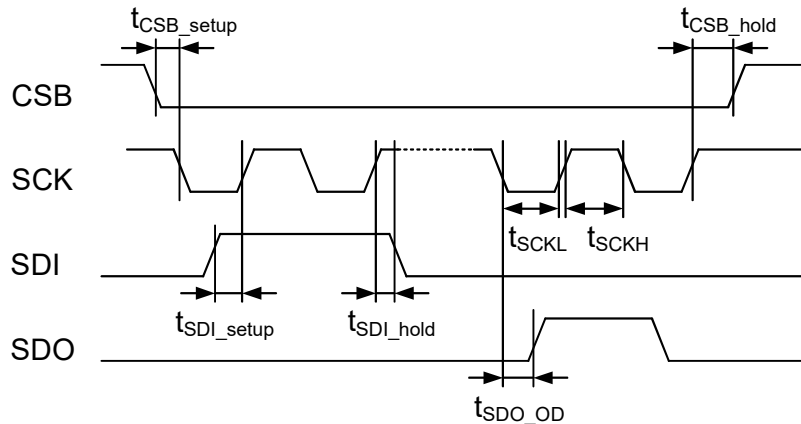

Figure 16: SPI timing diagram

The SPI interface of the BMC156 is compatible with two modes, “00” and “11”. The automatic selection between [CPOL = “0” and CPHA = “0”] and [CPOL = “1” and CPHA = “1”] is done based on the value of SCK after a falling edge of CSB.

Two configurations of the SPI interface are supported by the BMC156: 4-wire and 3-wire. The same protocol is used by both configurations. The device operates in 4-wire configuration by default. It can be switched to 3-wire configuration by writing “1” to (0x34) “spi3” for the accelerometer part and writing “1” to (0x4B) “SPI3en” for the magnetometer part (after power control bit was set). Pin SDI is used as the common data pin in 3-wire configuration. For single byte read as well as write operations, 16-bit protocols are used. The BMC156 also supports multiple-byte read operations.

In SPI 4-wire configuration CSB (chip select low active), SCK (serial clock), SDI (serial data input), and SDO (serial data output) pins are used. The communication starts when the CSB is pulled low by the SPI master and stops when CSB is pulled high. SCK is also controlled by SPI master. SDI and SDO are driven at the falling edge of SCK and should be captured at the rising edge of SCK.

The basic write operation waveform for 4-wire configuration is depicted in Figure 17. During the entire write cycle SDO remains in high-impedance state.

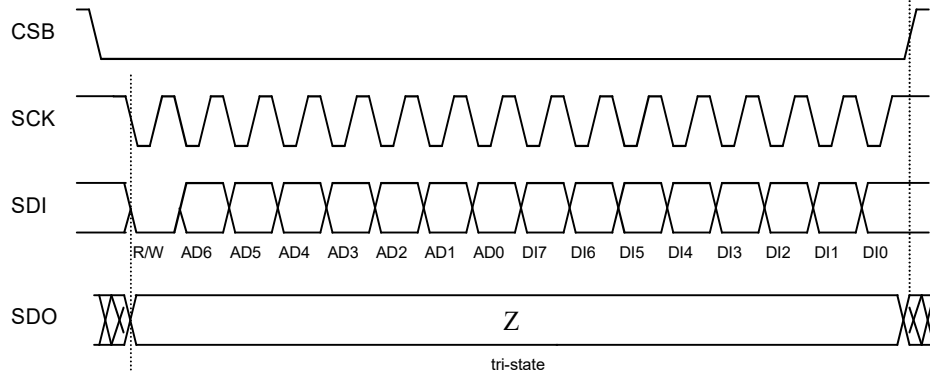

Figure 17: 4-wire basic SPI write sequence (mode “11”)

The basic read operation waveform for 4-wire configuration is depicted in Figure 18:

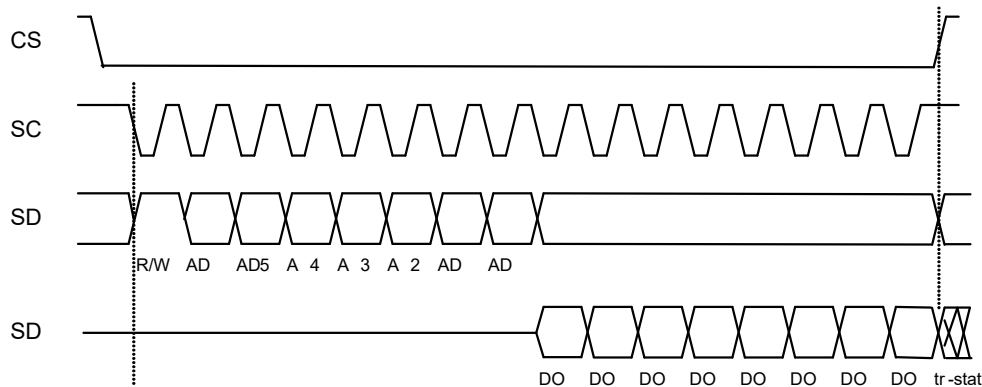

Figure 18: 4-wire basic SPI read sequence (mode “11”)

The data bits are used as follows:

Bit0: Read/Write bit. When 0, the data SDI is written into the chip. When 1, the data SDO from the chip is read.

Bit1-7: Address AD(6:0).

Bit8-15: when in write mode, these are the data SDI, which will be written into the address. When in read mode, these are the data SDO, which are read from the address.

Multiple read operations are possible by keeping CSB low and continuing the data transfer. Only the first register address has to be written. Addresses are automatically incremented after each read access as long as CSB stays active low. Note that a complete burst read over accelerometer and magnetometer register addresses is not supported. Instead, a second burst read must be started at address 0x40 if the entire BMC156 memory map is to be read.

The principle of multiple read is shown in Figure 19:

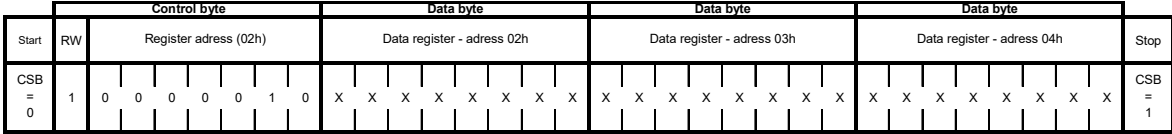

Figure 19: SPI multiple read

In SPI 3-wire configuration CSB (chip select low active), SCK (serial clock), and SDI (serial data input and output) pins are used. The communication starts when the CSB is pulled low by the SPI master and stops when CSB is pulled high. SCK is also controlled by SPI master. SDI is driven (when used as input of the device) at the falling edge of SCK and should be captured (when used as the output of the device) at the rising edge of SCK.

The protocol as such is the same in 3-wire configuration as it is in 4-wire configuration. The basic operation waveform (read or write access) for 3-wire configuration is depicted in Figure 20:

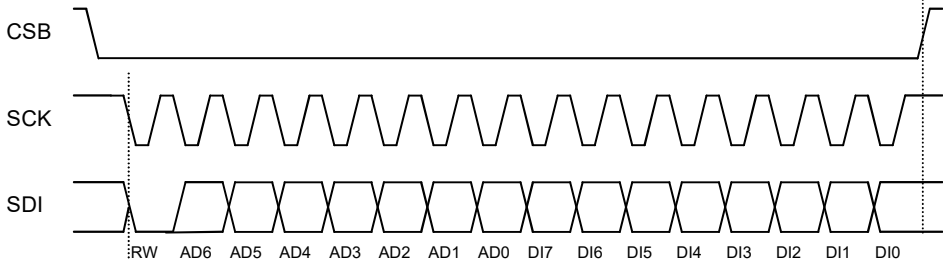

Figure 20: 3-wire basic SPI read or write sequence (mode "11")

8.2 Inter-Integrated Circuit (I²C)

The I²C bus uses SCL (= SCK pin, serial clock) and SDA (= SDI pin, serial data input and output) signal lines. Both lines must be connected to V_{DDIO} externally via pull-up resistors so that they are pulled high when the bus is free.

The I²C interface of the BMC156 is compatible with the I²C Specification UM10204 Rev. 03 (19 June 2007), available at <http://www.nxp.com>. The BMC156 supports I²C standard mode and fast mode, only 7-bit address mode is supported.

An overview is given in the table below:

Table 47: BMC156 I²C addresses

CSB pin	SDO pin	Accelerometer part I ² C address	Magnetometer part I ² C address
VDDIO	GND	0x10	0x12
VDDIO	VDDIO	0x11	0x13

The timing specification for I²C of the BMC156 is given in:

Table 48: I²C timings

Parameter	Symbol	Condition	Min	Max	Units
Clock Frequency	f _{SCL}			400	kHz
SCL Low Period	t _{LOW}		1.3		μs
SCL High Period	t _{HIGH}		0.6		
SDA Setup Time	t _{SUDAT}		0.1		
SDA Hold Time	t _{HDDAT}		0.0		
Setup Time for a repeated Start Condition	t _{SUSTA}		0.6		
Hold Time for a Start Condition	t _{HDSTA}		0.6		
Setup Time for a Stop Condition	t _{SUSTO}		0.6		
Time before a new Transmission can start	t _{BUF}		1.3		
Idle time between write accesses, normal mode, standby mode, low-power mode 2	t _{IDLE wacc n m}		2		
Idle time between write accesses, suspend mode, low-power mode 1	t _{IDLE wacc s um}		450		

Below Figure shows the definition of the I²C timings given in Table 48: I²C timings:

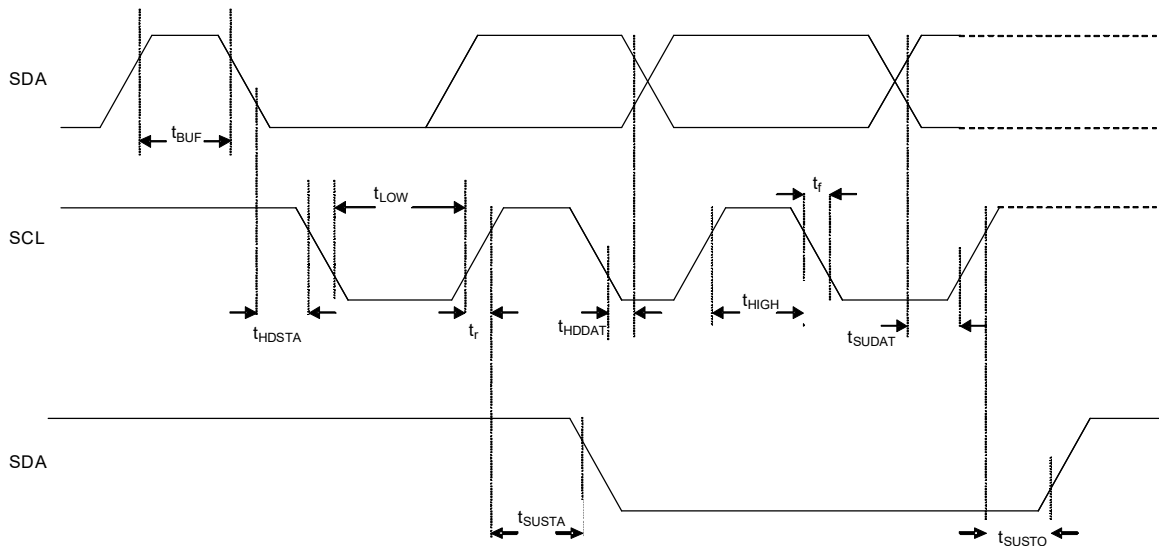

Figure 21: I²C timing diagram

The I²C protocol works as follows:

START: Data transmission on the bus begins with a high to low transition on the SDA line while SCL is held high (start condition (S) indicated by I²C bus master). Once the START signal is transferred by the master, the bus is considered busy.

STOP: Each data transfer should be terminated by a Stop signal (P) generated by master. The STOP condition is a low to HIGH transition on SDA line while SCL is held high.

ACK: Each byte of data transferred must be acknowledged. It is indicated by an acknowledge bit sent by the receiver. The transmitter must release the SDA line (no pull down) during the acknowledge pulse while the receiver must then pull the SDA line low so that it remains stable low during the high period of the acknowledge clock cycle.

In the following diagrams these abbreviations are used:

S	Start
P	Stop
ACKS	Acknowledge by slave
ACKM	Acknowledge by master
NACKM	Not acknowledge by master
RW	Read / Write

A START immediately followed by a STOP (without SCK toggling from logic "1" to logic "0") is not supported. If such a combination occurs, the STOP is not recognized by the device.

I²C write access:

I²C write access can be used to write a data byte in one sequence.

The sequence begins with start condition generated by the master, followed by 7 bits slave address and a write bit (RW = 0). The slave sends an acknowledge bit (ACK = 0) and releases the bus. Then the master sends the one byte register address. The slave again acknowledges the transmission and waits for the 8 bits of data which shall be written to the specified register address. After the slave acknowledges the data byte, the master generates a stop signal and terminates the writing protocol.

Example of an I²C write access:

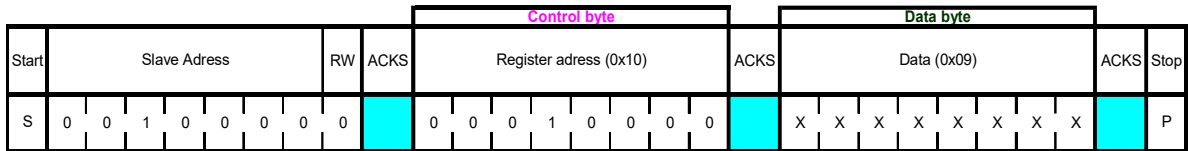

Figure 22: Example of an I²C write access

I²C read access:

I²C read access also can be used to read one or multiple data bytes in one sequence.

A read sequence consists of a one-byte I²C write phase followed by the I²C read phase. The two parts of the transmission must be separated by a repeated start condition (Sr). The I²C write phase addresses the slave and sends the register address to be read. After slave acknowledges the transmission, the master generates again a start condition and sends the slave address together with a read bit (RW = 1). Then the master releases the bus and waits for the data bytes to be read out from slave. After each data byte the master has to generate an acknowledge bit (ACK = 0) to enable further data transfer. A NACKM (ACK = 1) from the master stops the data being transferred from the slave. The slave releases the bus so that the master can generate a STOP condition and terminate the transmission.

The register address is automatically incremented and, therefore, more than one byte can be sequentially read out. Once a new data read transmission starts, the start address will be set to the register address specified in the latest I²C write command. By default the start address is set at 0x00. In this way repetitive multi-bytes reads from the same starting address are possible.

In order to prevent the I²C slave of the device to lock-up the I²C bus, a watchdog timer (WDT) is implemented in the accelerometer part of BMC156. The WDT observes internal I²C signals and resets the I²C interface if the bus is locked-up by the BMC156 accelerometer part. The activity and the timer period of the WDT can be configured through the bits (0x34) *i2c_wdt_en* and (0x34) *i2c_wdt_sel*.

Writing '1' ('0') to (0x34) *i2c_wdt_en* activates (de-activates) the WDT. Writing "0" ("1") to (0x34) *i2c_wdt_sel* selects a timer period of 1 ms (50 ms).

9. Pin-out and connection diagram

9.1 Pin-out

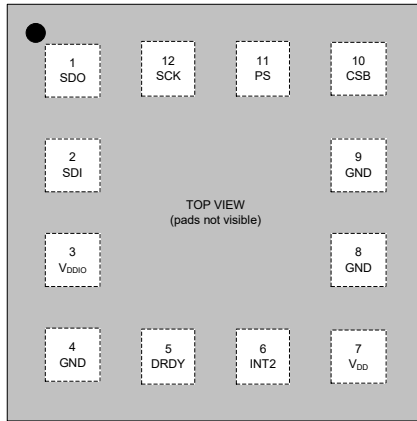

Figure 25: Pin-out top view

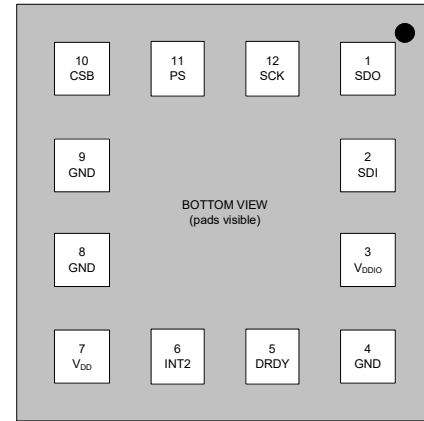

Figure 26: Pin-out bottom view

Table 49: Pin description

Pin	Name	I/O Type	Sensor	Description	Connect to		
					SPI4W	SPI3W	I ² C
1	SDO	Out	Mag+Acc	SPI: Data out	SDO / MISO	DNC (float)	GND for default address
2	SDI	In/Out	Mag+Acc	SPI: Data in, I ² C: Data	SDI / MOSI	SDA	SDA
3	VDDIO	Supply	Mag+Acc	I/O voltage	V _{DDIO}		
4	GND ⁹	In	Mag	Ground ⁹	GND ⁹		
5	DRDY	Out	Mag	Data ready	DRDY input or DNC if unused		
6	INT2	Out	Acc	Interrupt output #2	INT2 input or DNC if unused		
7	VDD	Supply	Mag+Acc	Supply voltage	V _{DD}		
8	GND	In	Mag	Ground	GND		
9	GND	Supply	Mag+Acc	Ground	GND		
10	CSB	In	Mag+Acc	Chip Select	CSB	CSB	DNC (float) or V _{DDIO}
11	PS	In	Mag+Acc	Protocol select	GND	GND	V _{DDIO}
12	SCK	In	Mag+Acc	Serial clock	SCK	SCK	SCL

⁹ GND connection is recommended but not required (alternative: do not connect)

9.2 Connection diagram 4-wire SPI

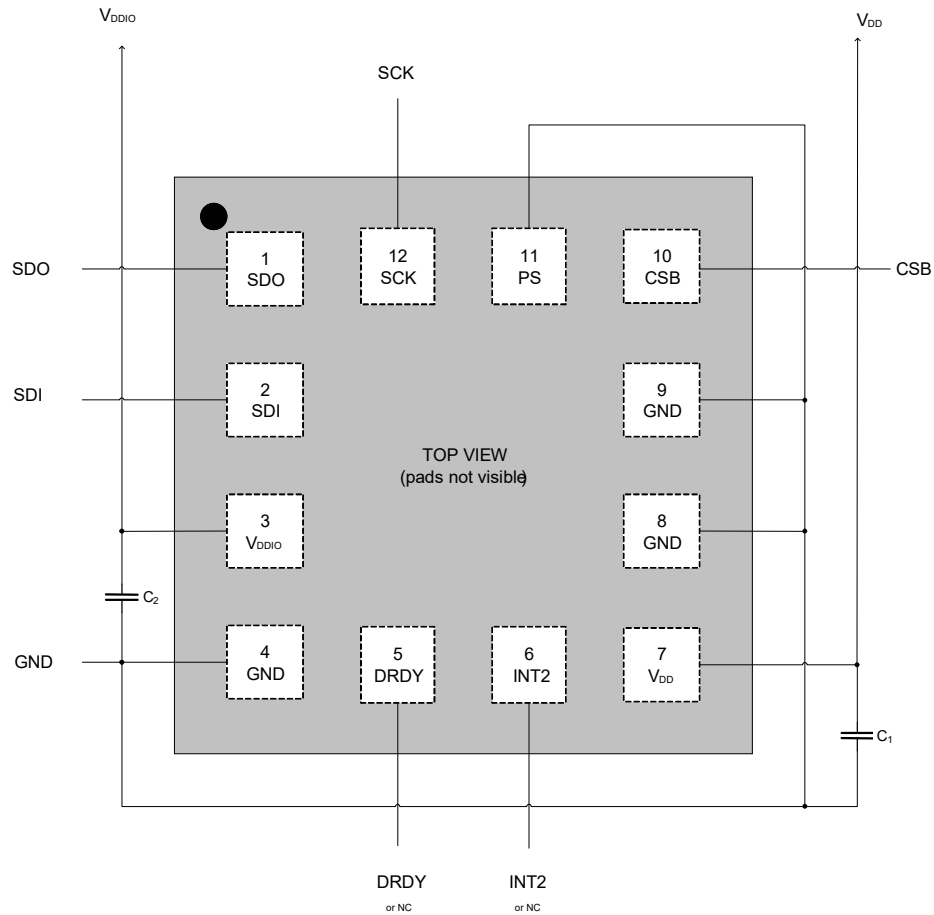

Figure 27: 4-wire SPI connection diagram

Note:

The recommended value for C_1 and C_2 is 100 nF.

9.3 Connection diagram 3-wire SPI

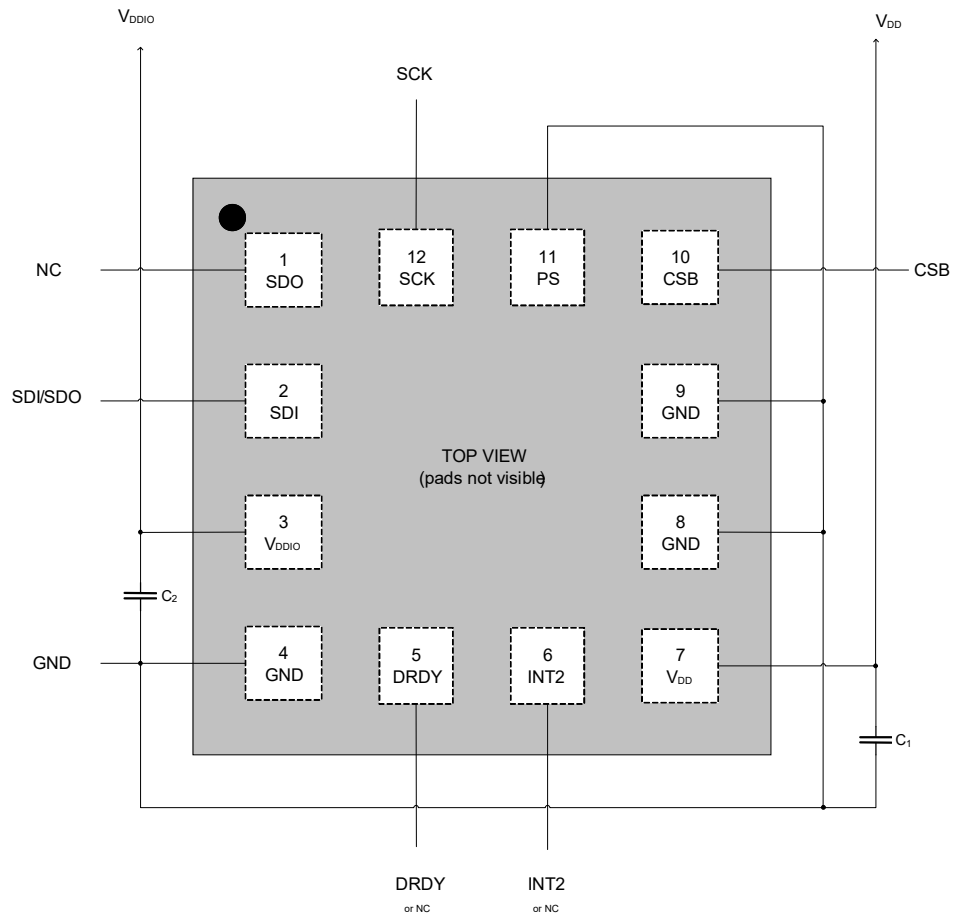

Figure 28: 3-wire SPI connection diagram

Note:

The recommended value for C_1 and C_2 is 100 nF.

9.4 Connection diagram I²C

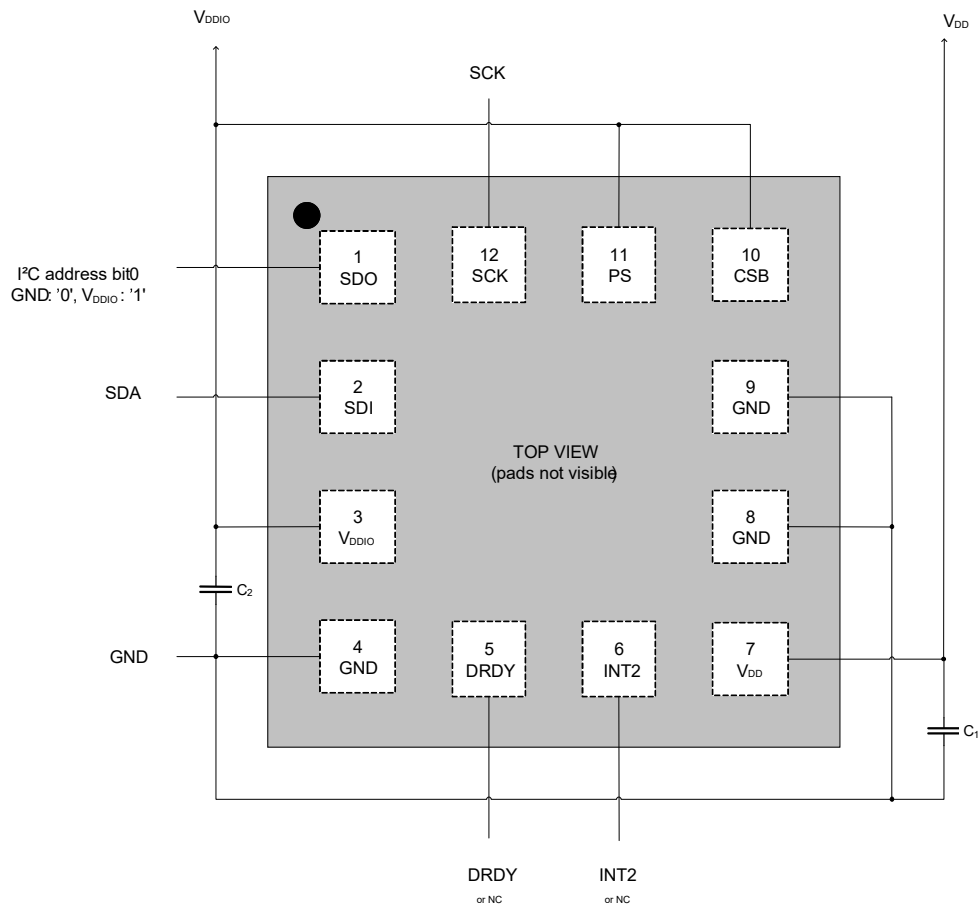

Figure 29: I²C connection diagram

Note:

The recommended value for C₁ and C₂ is 100 nF.

10. Package

10.1 Outline dimensions

The sensor housing is a standard LGA 2.2 x 2.2 12-lead package. Its dimensions are the following:

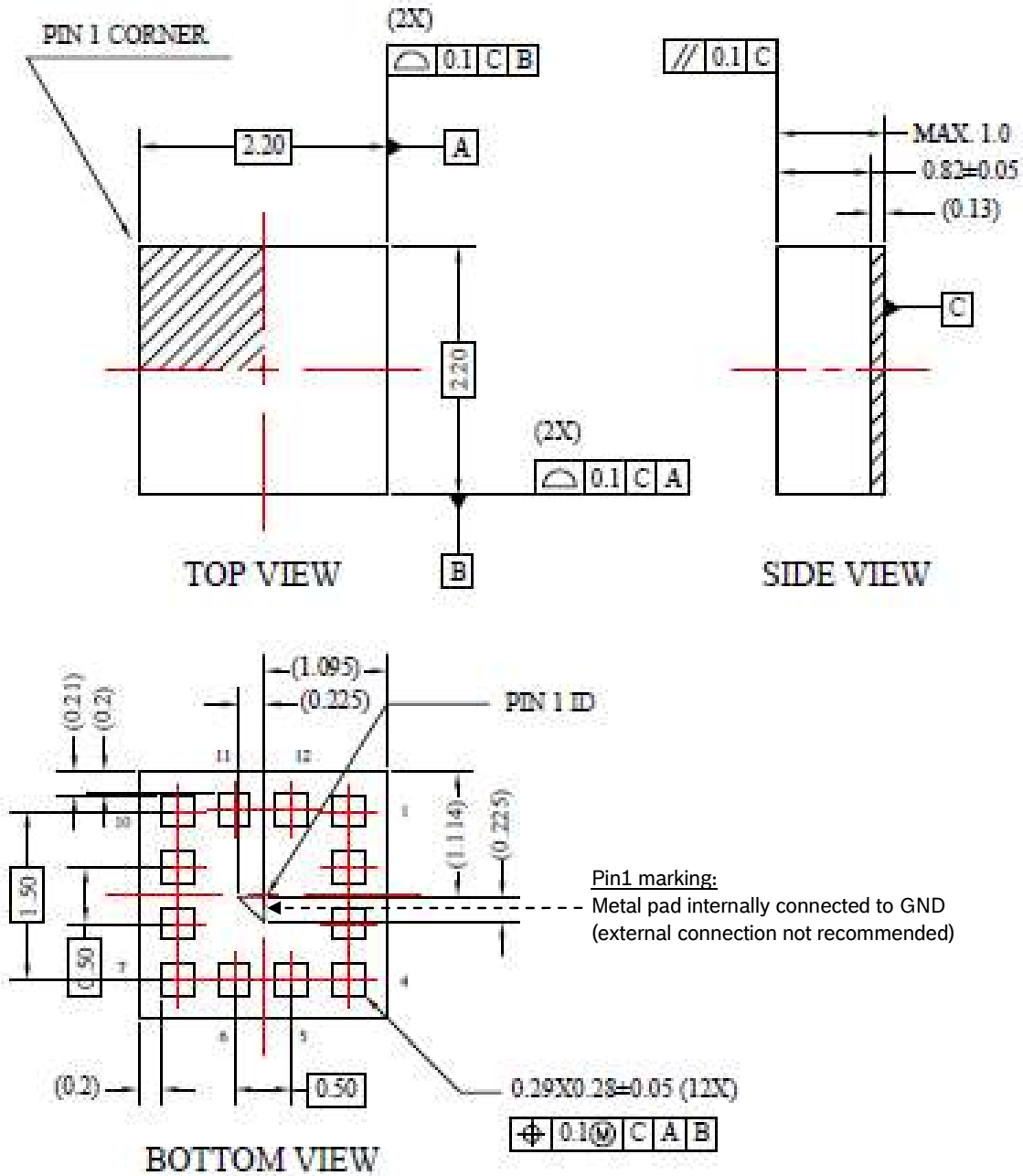

Figure 30: Package outline dimensions

10.2 Sensing axes orientation

The magnetic and acceleration sensing axes of the BMC156 are matching. If the sensor is accelerated in the indicated directions, the corresponding channel will deliver a positive acceleration signal (dynamic acceleration). If the sensor is at rest and the force of gravity is acting along the indicated directions, the output of the corresponding channel will be negative (static acceleration). If a positive magnetic field is applied in the indicated directions, the corresponding channel will deliver a positive acceleration signal.

Example: If the sensor is at rest or at uniform motion in a gravitational and magnetic field according to the figure given below, the output signals are

- 0 g for the X acceleration channel, 0 μT for the X magnetic channel
- 0 g for the Y acceleration channel, 0 μT for the Y magnetic channel
- +1 g for the Z acceleration channel, $-|B|$ for the Z magnetic channel

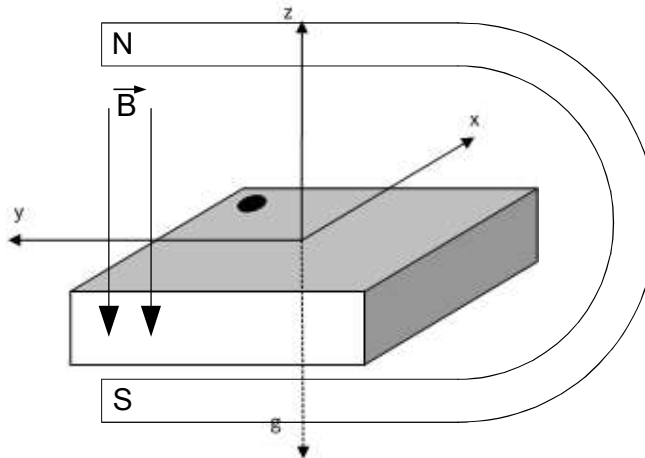

Figure 31: Orientation of sensing axes (acceleration and magnetic)

Please note that the planet's North pole is a magnetic south pole. This means that when the BMC156's X axis points towards the North pole, the measured field will be negative. The following table lists all corresponding output signals on X, Y, and Z while the sensor is at rest or at uniform motion in a gravity field under assumption of a $\pm 2g$ range setting and a top down gravity and magnetic vector as shown above.

Table 50: Output signals depending on sensor orientation

Sensor Orientation (gravity vector \downarrow = acceleration vector \uparrow , magnetic vector \downarrow)						
Output Signal X	0g / 0LSB 0 μT	+1g / 256LSB $- B \mu\text{T}$	0g / 0LSB 0 μT	-1g / - 256LSB $+ B \mu\text{T}$	0g / 0LSB 0 μT	0g / 0LSB 0 μT
Output Signal Y	-1g / - 256LSB $+ B \mu\text{T}$	0g / 0LSB 0 μT	+1g / 256LSB $- B \mu\text{T}$	0g / 0LSB 0 μT	0g / 0LSB 0 μT	0g / 0LSB 0 μT
Output Signal Z	0g / 0LSB 0 μT	0g / 0LSB 0 μT	0g / 0LSB 0 μT	0g / 0LSB 0 μT	+1g / 256LSB $- B \mu\text{T}$	-1g / - 256LSB $+ B \mu\text{T}$

10.3 Android axes orientation

The Android coordinate system is shown in Figure 32. The origin is in the lower-left corner with respect to the screen, with the X axis horizontal and pointing right, the Y axis vertical and pointing up and the Z axis pointing outside the front face of the screen. In this system, coordinates behind the screen have negative Z values.

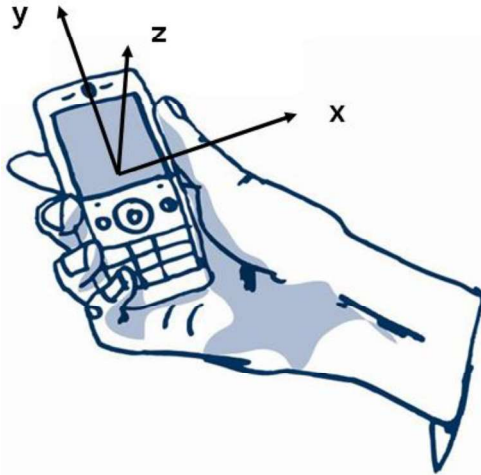

Figure 32: Android coordinate system

Attitude terms are defined in the following way (see Figure 33):

- Heading / Azimuth – angle between the magnetic north direction and the Y axis, around the Z axis (0° to 360°). 0° = North, 90° = East, 180° = South, 270° = West.
- Pitch – rotation around X axis (-180° to 180°), with positive values when the z-axis moves toward the y-axis.
- Roll – rotation around Y axis (-90° to 90°), with positive values when the x-axis moves toward the z-axis.

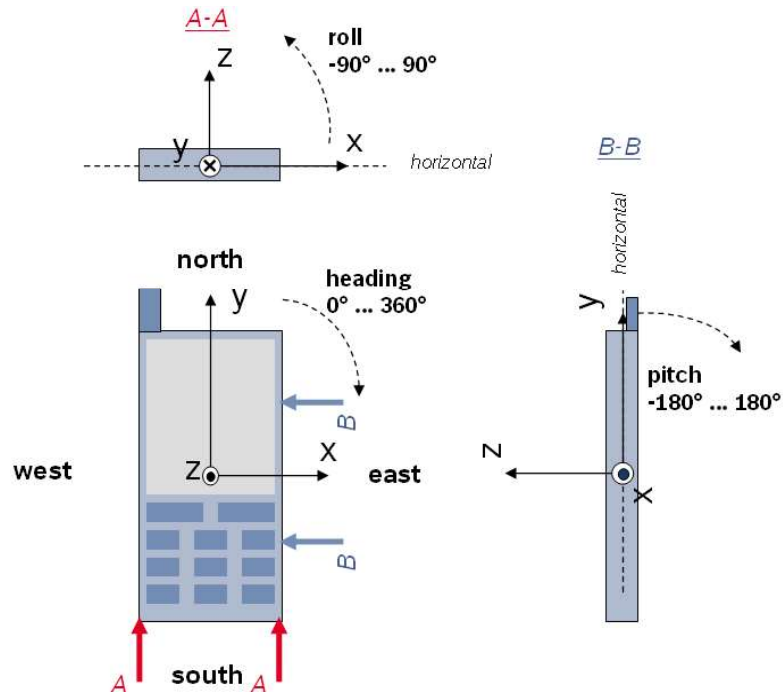

Figure 33: Heading, pitch and roll in Android coordinate frame

10.4 Landing pattern recommendation

For the design of the landing pattern, we recommend the following dimensioning:

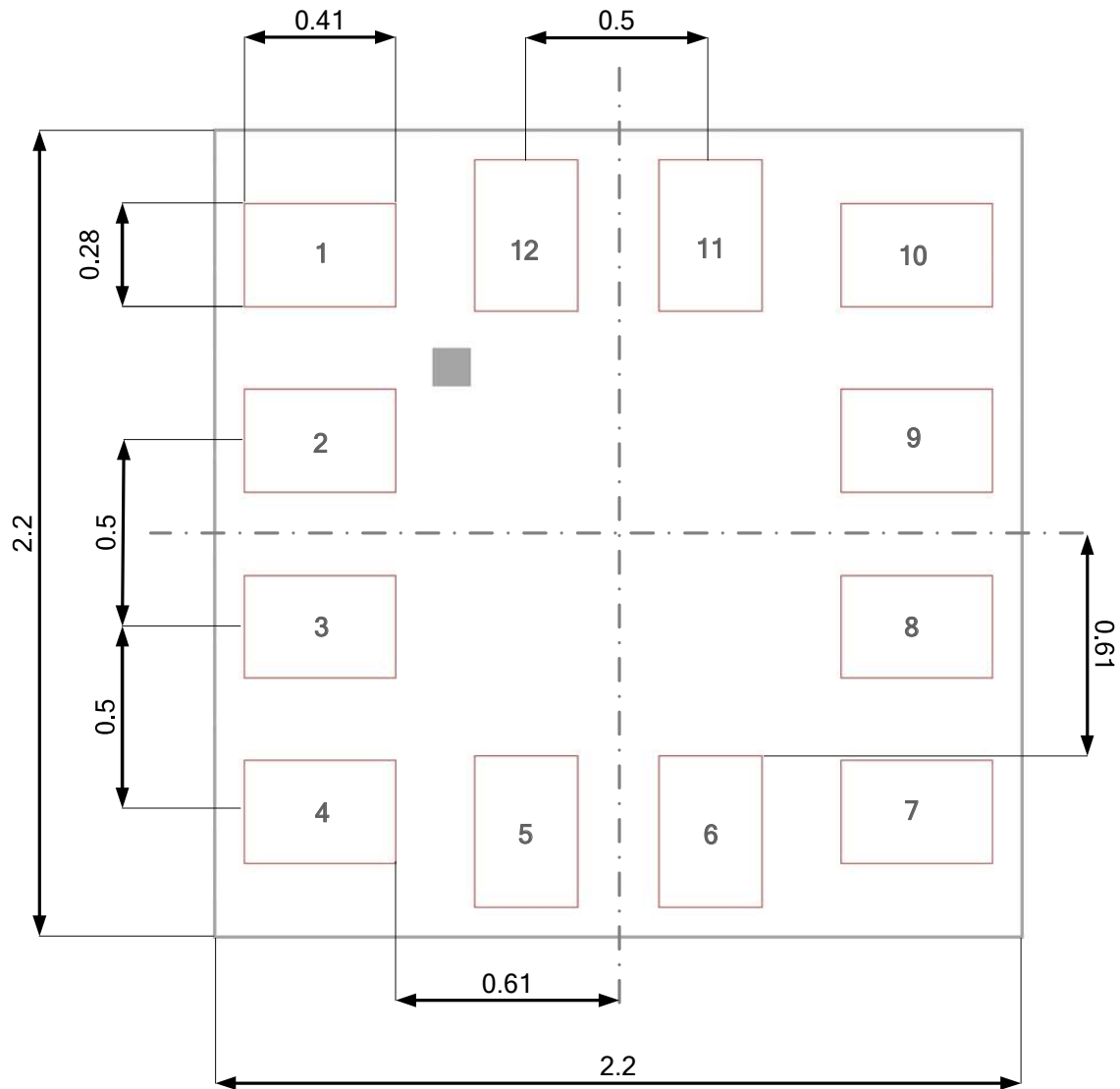
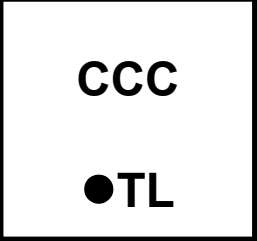

Figure 34: Landing patterns relative to the device pins, dimensions are in mm

10.5 Marking

10.5.1 Mass production devices

Table 51: Marking of mass production samples

Labeling	Name	Symbol	Remark
	First letter of second row	T	internal use
	Second letter of second row	L	internal use
	Lot counter	CCC	Numerical counter
	Pin 1 identifier	●	

10.5.2 Engineering samples

Table 52: Marking of engineering samples

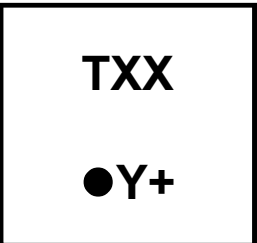
Labeling	Name	Symbol	Remark
	Product number	T	1 alphanumeric digit, fixed to identify product type, T = "C"
	Engineering lot	XX	2 alphanumeric digits to identify the engineering lot
	Sample Stage	Y	"A" for A-samples, "C" for C-samples
	Sample status	Cx	x = Numerical counter
	Pin 1 identifier	●	

10.6 Soldering guidelines

The moisture sensitivity level of the BMC156 sensors corresponds to JEDEC Level 1, see also:

- IPC/JEDEC J-STD-020C “Joint Industry Standard: Moisture/Reflow Sensitivity Classification for non-hermetic Solid State Surface Mount Devices”
- IPC/JEDEC J-STD-033A “Joint Industry Standard: Handling, Packing, Shipping and Use of Moisture/Reflow Sensitive Surface Mount Devices”.

The sensor fulfils the lead-free soldering requirements of the above-mentioned IPC/JEDEC standard, i.e. reflow soldering with a peak temperature up to 260°C.

Profile Feature	Pb-Free Assembly
Average Ramp-Up Rate ($T_{S_{max}}$ to T_p)	3° C/second max.
Preheat – Temperature Min ($T_{S_{min}}$) – Temperature Max ($T_{S_{max}}$) – Time ($t_{s_{min}}$ to $t_{s_{max}}$)	150 °C 200 °C 60-180 seconds
Time maintained above: – Temperature (T_L) – Time (t_L)	217 °C 60-150 seconds
Peak/Classification Temperature (T_p)	260 °C
Time within 5 °C of actual Peak Temperature (t_p)	20-40 seconds
Ramp-Down Rate	6 °C/second max.
Time 25 °C to Peak Temperature	8 minutes max.

Note 1: All temperatures refer to topside of the package, measured on the package body surface.

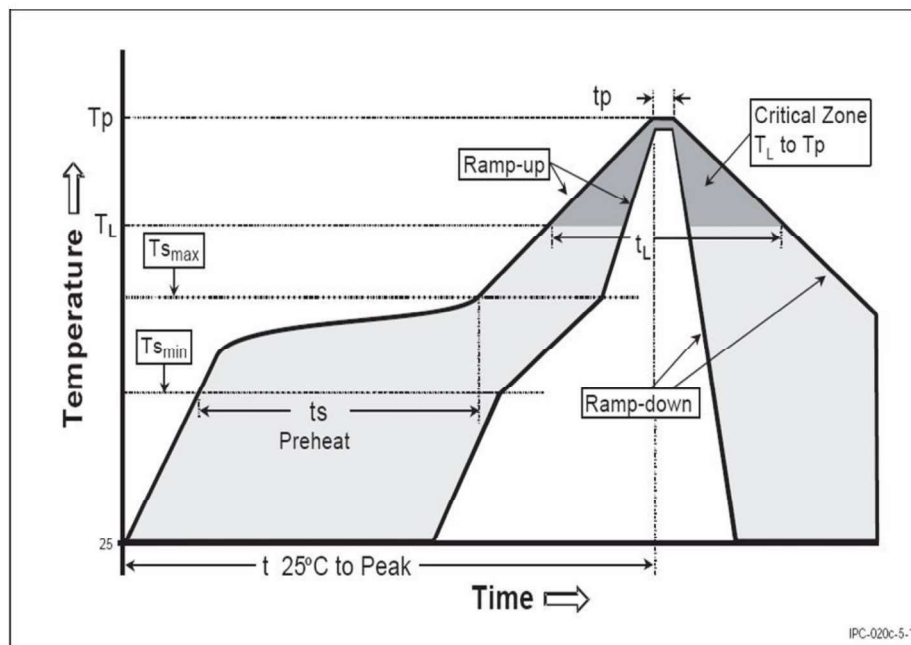

Figure 35: Soldering profile

10.7 Handling instructions

Micromechanical sensors are designed to sense acceleration with high accuracy even at low amplitudes and contain highly sensitive structures inside the sensor element. The MEMS sensor can tolerate mechanical shocks up to several thousand g. However, these limits might be exceeded in conditions with extreme shock loads such as e.g. hammer blow on or next to the sensor, dropping of the sensor onto hard surfaces etc.

We recommend avoiding g-forces beyond the specified limits during transport, handling and mounting of the sensors in a defined and qualified installation process.

This device has built-in protections against high electrostatic discharges or electric fields (e.g. 2kV HBM); however, anti-static precautions should be taken as for any other CMOS component. Unless otherwise specified, proper operation can only occur when all terminal voltages are kept within the supply voltage range. Unused inputs must always be tied to a defined logic voltage level.

10.8 Tape and reel specification

10.8.1 Tape and reel dimensions

The following picture describes the dimensions of the tape used for shipping the BMC156 sensor device. The material of the tape is made of conductive polystyrene (IV).

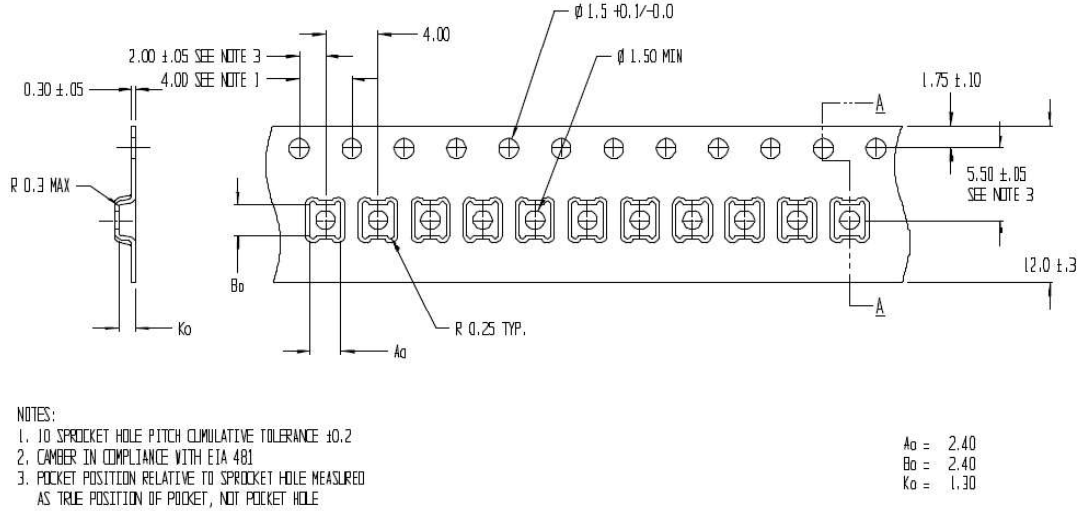

Figure 36: Tape and reel dimensions in mm

10.8.2 Orientation within the reel

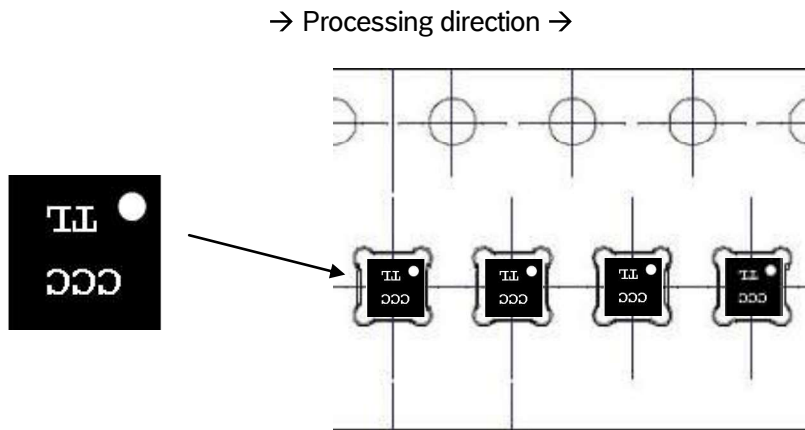

Figure 37: Orientation of the BMC156 devices relative to the tape

10.9 Environmental safety

The BMC156 sensor meets the requirements of the EC restriction of hazardous substances (RoHS) directive, see also:

Directive 2002/95/EC of the European Parliament and of the Council of 8 September 2011 on the restriction of the use of certain hazardous substances in electrical and electronic equipment.

10.9.1 Halogen content

The BMC156 is halogen-free. For more details on the analysis results please contact your Bosch Sensortec representative.

10.9.2 Internal package structure

Within the scope of Bosch Sensortec's ambition to improve its products and secure the mass product supply, Bosch Sensortec qualifies additional sources (e.g. 2nd source) for the LGA package of the BMC156.

While Bosch Sensortec took care that all of the technical packages parameters are described above are 100% identical for all sources, there can be differences in the chemical content and the internal structural between the different package sources.

However, as secured by the extensive product qualification process of Bosch Sensortec, this has no impact to the usage or to the quality of the BMC156 product.

11. Legal disclaimer

11.1 Engineering samples

Engineering Samples are marked with an asterisk (*) or (e) or (E). Samples may vary from the valid technical specifications of the product series contained in this data sheet. They are therefore not intended or fit for resale to third parties or for use in end products. Their sole purpose is internal client testing. The testing of an engineering sample may in no way replace the testing of a product series. Bosch Sensortec assumes no liability for the use of engineering samples. The Purchaser shall indemnify Bosch Sensortec from all claims arising from the use of engineering samples.

11.2 Product use

Bosch Sensortec products are developed for the consumer goods industry. They may only be used within the parameters of this product data sheet. They are not fit for use in life-sustaining or security sensitive systems. Security sensitive systems are those for which a malfunction is expected to lead to bodily harm or significant property damage. In addition, they are not fit for use in products which interact with motor vehicle systems.

The resale and/or use of products are at the purchaser's own risk and his own responsibility. The examination of fitness for the intended use is the sole responsibility of the Purchaser.

The purchaser shall indemnify Bosch Sensortec from all third party claims arising from any product use not covered by the parameters of this product data sheet or not approved by Bosch Sensortec and reimburse Bosch Sensortec for all costs in connection with such claims.

The purchaser must monitor the market for the purchased products, particularly with regard to product safety, and inform Bosch Sensortec without delay of all security relevant incidents.

11.3 Application examples and hints

With respect to any examples or hints given herein, any typical values stated herein and/or any information regarding the application of the device, Bosch Sensortec hereby disclaims any and all warranties and liabilities of any kind, including without limitation warranties of non-infringement of intellectual property rights or copyrights of any third party. The information given in this document shall in no event be regarded as a guarantee of conditions or characteristics. They are provided for illustrative purposes only and no evaluation regarding infringement of intellectual property rights or copyrights or regarding functionality, performance or error has been made.

12. Document history and modification

Rev. No	Chapter	Description of modification/changes	Date
0.1		Document creation	2014-02-11
1.0	1.2, 2, 4.2.1, 4.5.1, 4.7.6, 6.15, 8.2, 9.1, 10.1	Updates	2014-07-16

Bosch Sensortec GmbH
Gerhard-Kindler-Strasse 8
72770 Reutlingen / Germany

contact@bosch-sensortec.com
www.bosch-sensortec.com

Modifications reserved | Printed in Germany
Specifications subject to change without notice
Document number: BST-BMC156-DS000-01
Version_1.0_072014



Looking for pricing, stock, or lifecycle information?

Click below to explore more details on WIN SOURCE:

 [View BMC156 on WIN SOURCE](#)

 [Bosch Sensortec Information](#)

Optimize Your Supply Chain with WIN SOURCE Solutions

-  Global Sourcing Solution
-  Obsolete Management
-  Cost Control Management
-  Shortage Management
-  Alternative Solution
-  Excess Inventory Management