



THE DATASHEET OF
0813-1X1T-57-F



THE INFORMATION CONTAINED HEREIN IS CONSIDERED "PROPRIETARY" TO BEL FUSE INC. AND SHALL NOT BE COPIED, REPRODUCED OR DISCLOSED WITHOUT THE WRITTEN APPROVAL OF BEL FUSE INC.

RoHS



ELECTRICAL CHARACTERISTICS @ 25°C

TURNS RATIO □CL @ 100kHz/100mVRMS 8mA DC BIAS INSERTION LOSS 100KHz TO 100MHZ RETURN LOSS (MIN.) 2MHz-30MHz 60MHz-80MHz CROSS TALK 100KHz - 100MHz HIPOT (ISOLATION VOLTAGE) 100% OF PRODUCTION TESTED TO COMPLY WITH IEEE 802.3 ISOLATION REQUIREMENTS BALANCED DC LINE CURRENT 350mA MAX. @ 57 VDC CONTINUOUS 500mA MAX. @ 57 VDC FOR 200 MILLSECONDS OPERATING TEMPERATURE: 0°C TO +70°C.	1CT : 1CT ±2% 350μH MIN. -1.5 dB MAX. -16 dB MIN. -10 dB MIN. -30 dB MIN. 2250 VDC 350mA MAX. @ 57 VDC CONTINUOUS 500mA MAX. @ 57 VDC FOR 200 MILLSECONDS 0°C TO +70°C.
---	--

SCHEMATIC

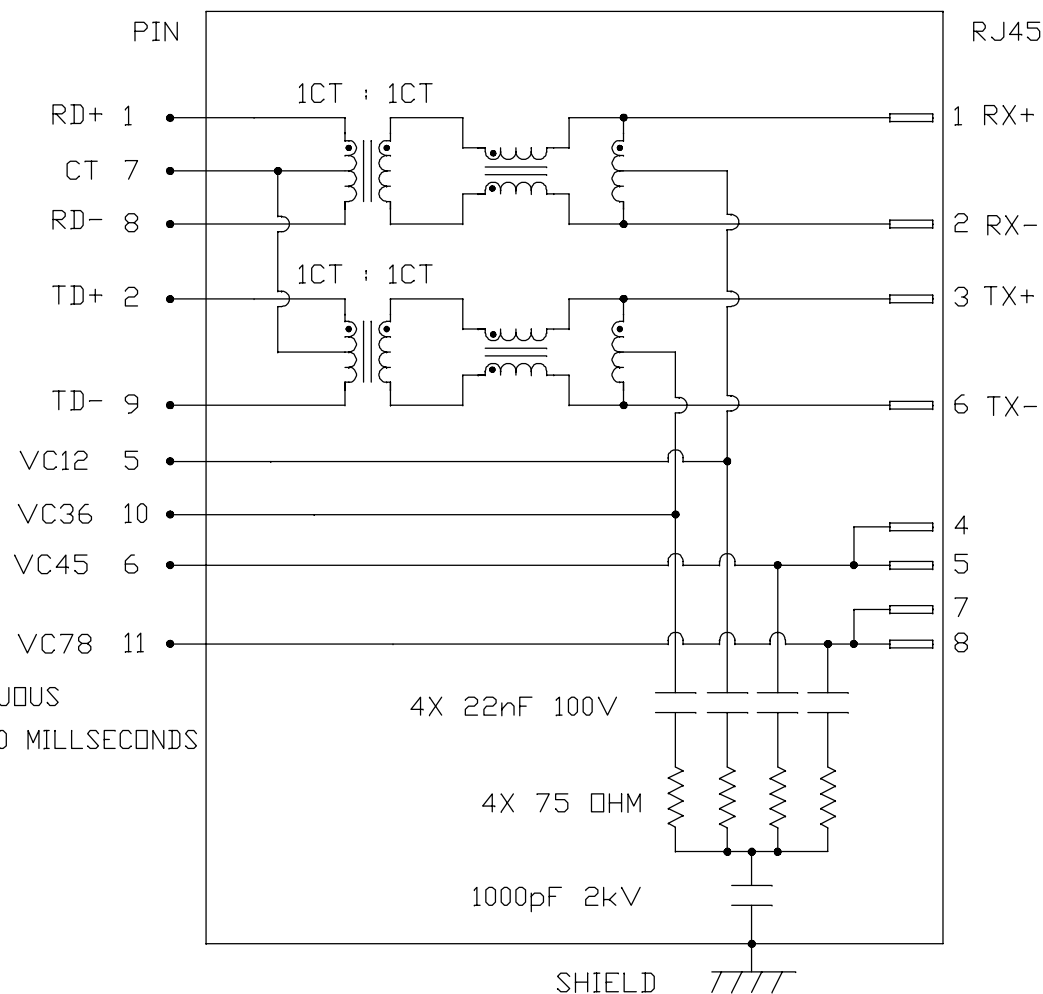

REV. : F PAGE : 2

ORIGINATED BY
CHOW WANCHUNG
DATE 2018-03-24
DRAWN BY
XIE YIMING
DATE 2018-03-24

TITLE
10/100 MagJack®
PoE
0813-1X1T-57-F

PART NO. / DRAWING NO.
08131X1T57-F
FILE NAME
08131X1T57-F_F.DWG

STANDARD DIM. TOL. IN INCH	[] METRIC DIM. AS REF.
.X	UNIT : INCH [mm]
.XX	SCALE : N/A
.XXX	SIZE : A4



THE INFORMATION CONTAINED HEREIN IS CONSIDERED "PROPRIETARY" TO BEL FUSE INC. AND SHALL NOT BE COPIED, REPRODUCED OR DISCLOSED WITHOUT THE WRITTEN APPROVAL OF BEL FUSE INC.

MECHANICAL SPECIFICATION

RoHS

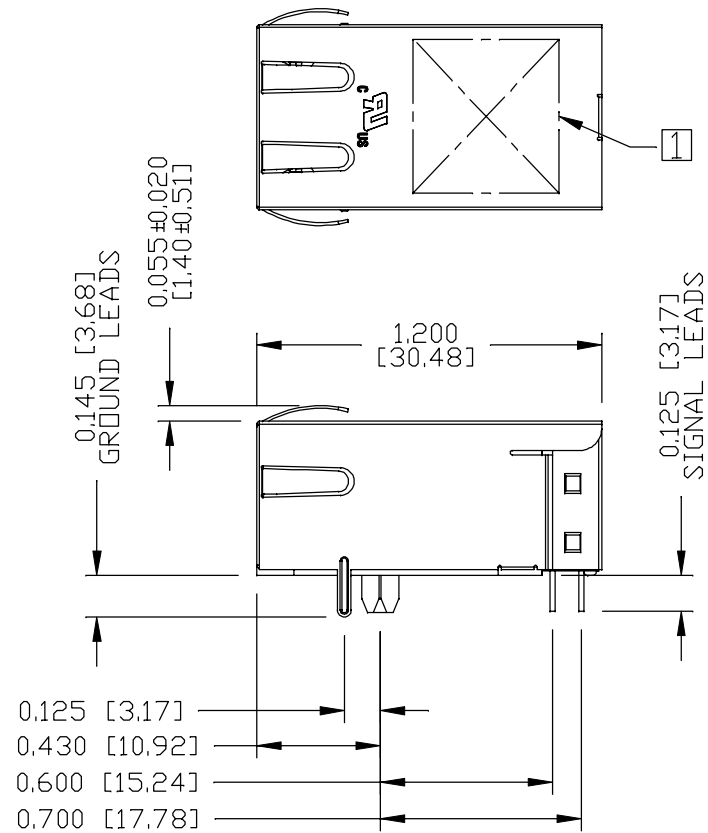
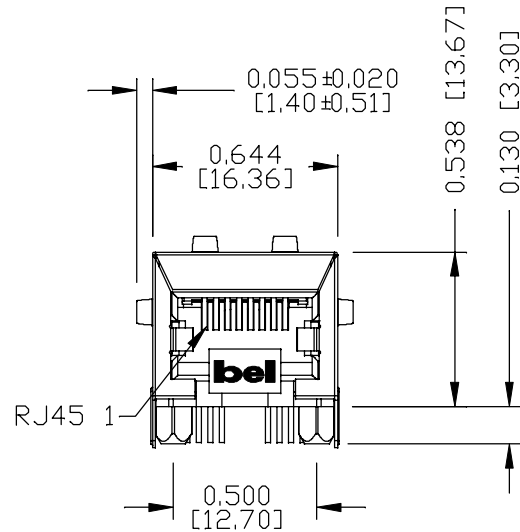

NOTES:

- PLASTIC HOUSING: THERMOPLASTIC PBT, BLACK
FLAMMABILITY RATING UL 94V-0
- CONTACTS: 50 MICRO-INCH HARD GOLD PLATING OR EQUIVALENT,
WITH UNDERPLATING OF 50 MICRO-INCH NICKEL.
- OUTPUT PINS: TIN-COATED COPPER WIRE, DIA 0.018 INCH.
100 MICRO-INCH MIN MATTE TIN. PINS ARE SOLDER DIPPED.
- METAL SHIELD: NICKEL PLATED ON COPPER ALLOY,
(ALL GROUND LEAD ARE SOLDER DIPPED)
- JACK CAVITY CONFORMS TO FCC RULES AND REGULATIONS.
- ① MARK PART WITH MFG LOGO, MFG NAME, PART NUMBER,
DATE CODE.

- 2. THE PRODUCT IS RoHS COMPLIANT.
- 3. THE PART IS RECOMMENDED FOR WAVE SOLDERING,
THE SUGGESTED PEAK WAVE SOLDERING CONDITION IS
260°C MAX AND 10 SECONDS MAX.

UL RECOGNIZED - FILE #E196366 AND E169987.

ORIGINATED BY
ANTON LIAO
DATE 2018-03-24
DRAWN BY
JESSE LI
DATE 2018-03-24

TITLE
10/100 MagJack®
PoE
0813-1X1T-57-F

PART NO. / DRAWING NO.
08131X1T57-F
FILE NAME
08131X1T57-F_F.DWG

STANDARD DIM. TOL. IN INCH		[] METRIC DIM. AS REF.
.X		UNIT : INCH [mm]
.XX		SCALE : N/A
.XXX	±0.010	SIZE : A4

REV. : F	PAGE : 3

THE INFORMATION CONTAINED HEREIN IS CONSIDERED "PROPRIETARY" TO BEL FUSE INC. AND SHALL NOT BE COPIED, REPRODUCED OR DISCLOSED WITHOUT THE WRITTEN APPROVAL OF BEL FUSE INC.

RoHS



RECOMMENDED PCB FOOTPRINT

COMPONENT SIDE VIEW

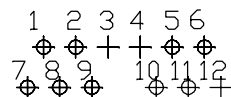
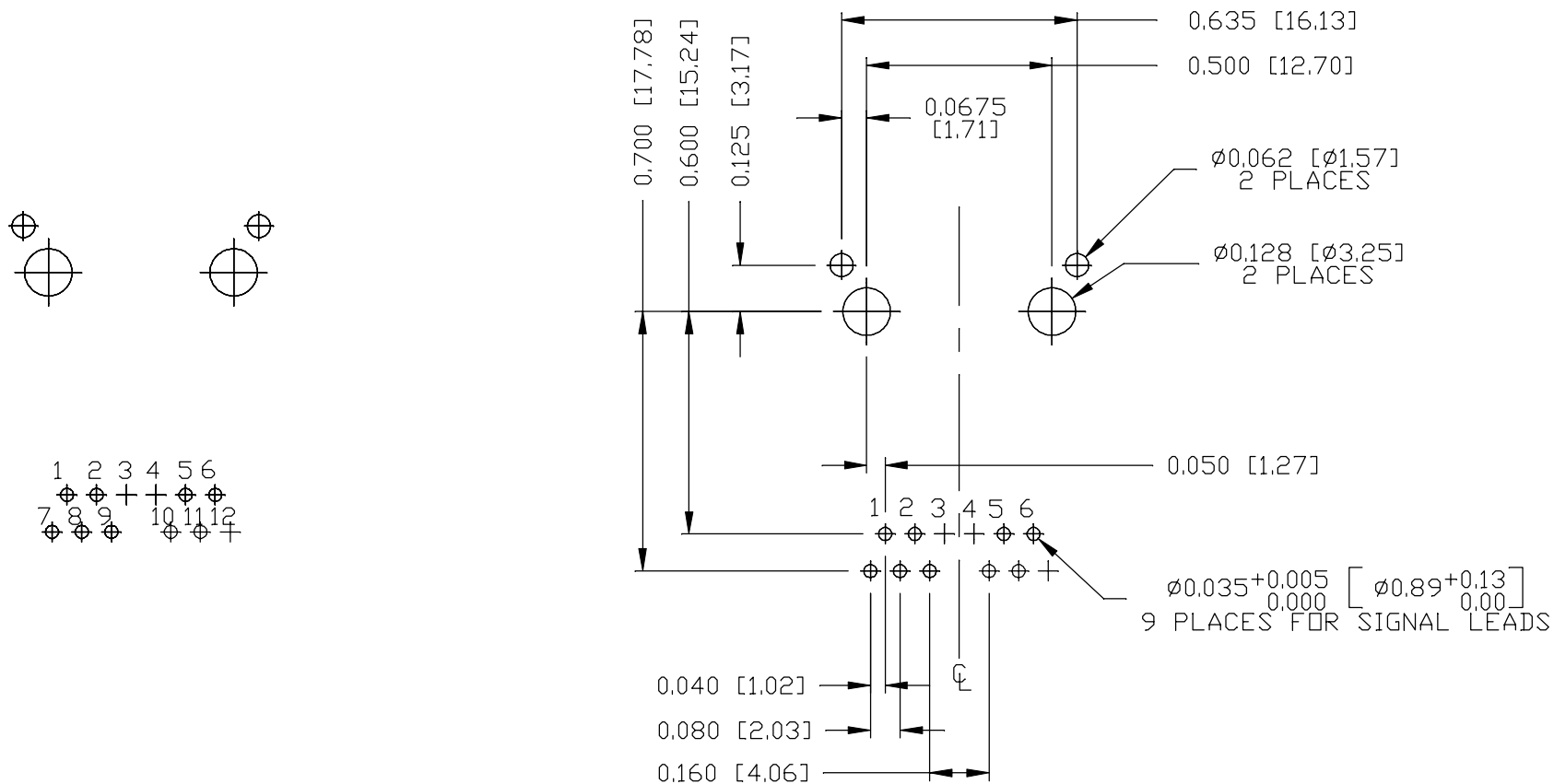

ORIGINATED BY
ANTON LIAO
DATE 2018-03-24

DRAWN BY
JESSE LI
DATE 2018-03-24

TITLE
10/100 MagJack®
PoE
0813-1X1T-57-F

PART NO. / DRAWING NO.
08131X1T57-F

FILE NAME
08131X1T57-F_F.DWG

STANDARD DIM. TOL. IN INCH	[] METRIC DIM. AS REF.
.X	UNIT : INCH [mm]
.XX	SCALE : N/A
.XXX	SIZE : A4

REV. : F PAGE : 4



THE INFORMATION CONTAINED HEREIN IS CONSIDERED "PROPRIETARY" TO BEL FUSE INC. AND SHALL NOT BE COPIED, REPRODUCED OR DISCLOSED WITHOUT THE WRITTEN APPROVAL OF BEL FUSE INC.

RoHS

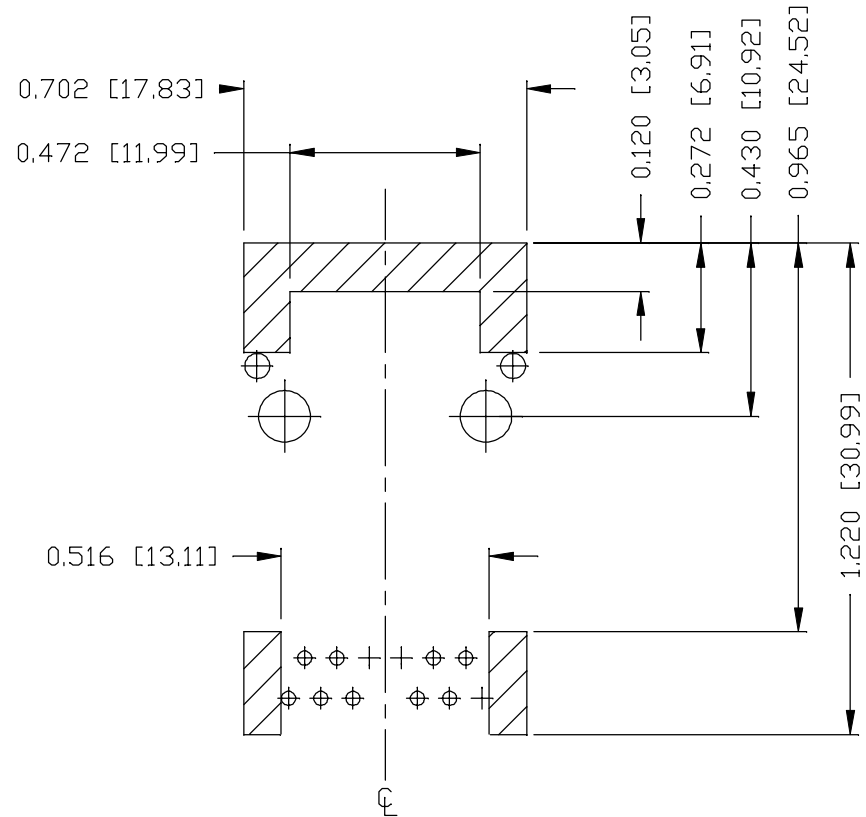

NOTES

THE SHADED AREA ON THE CUSTOMER BOARD ARE RECOMMENDED TO BE CLEAR OFF ANY VIA HOLE OR COMPONENT PAD.

ORIGINATED BY
ANTON LIAO
DATE 2018-03-24

DRAWN BY
JESSE LI
DATE 2018-03-24

TITLE
10/100 MagJack®
PoE
0813-1X1T-57-F

PART NO. / DRAWING NO.
08131X1T57-F

FILE NAME
08131X1T57-F_F.DWG

STANDARD DIM. TOL. IN INCH	[] METRIC DIM. AS REF.
.X	UNIT : INCH [mm]
.XX	SCALE : N/A
.XXX	±0.004
	SIZE : A4

REV. : F PAGE : 5



THE INFORMATION CONTAINED HEREIN IS CONSIDERED "PROPRIETARY" TO BEL FUSE INC. AND SHALL NOT BE COPIED, REPRODUCED OR DISCLOSED WITHOUT THE WRITTEN APPROVAL OF BEL FUSE INC.



SUGGESTED PANEL OPENING

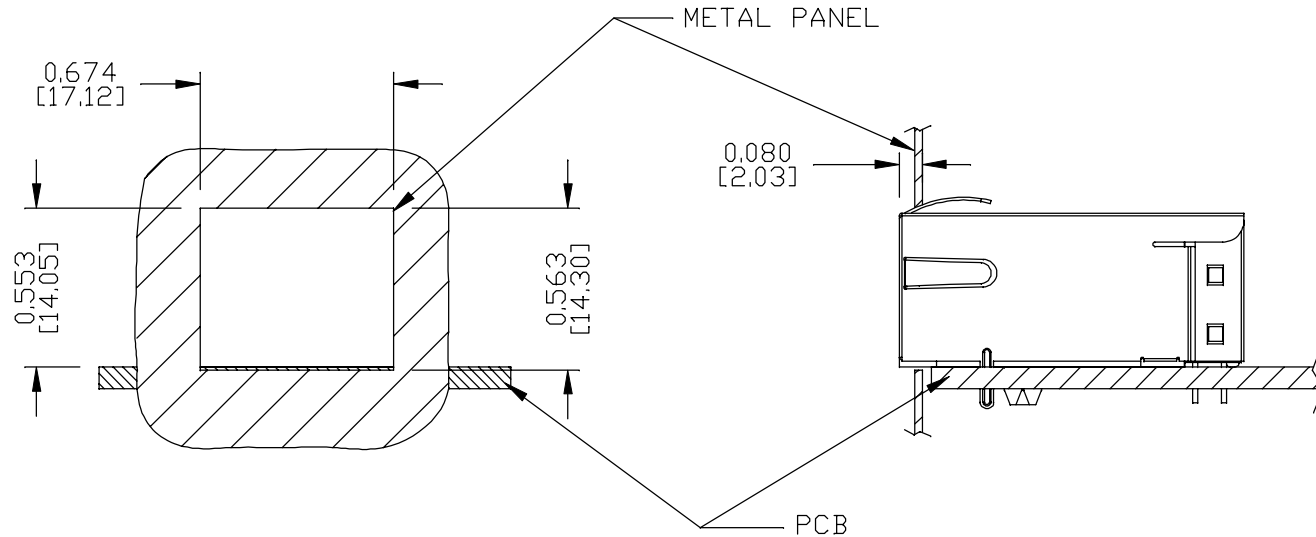

NOTES:

THE DISTANCE OF PANEL INSIDE SURFACE RELATIVE TO FRONT SURFACE OF PART IS ONLY A SUGGESTION. IN CASE THIS DISTANCE IS DIFFERENT, THE REQUIRED PANEL OPENING DIMENSIONS CHANGE ACCORDINGLY.
PACKING INFORMATION

PACKING TRAY : 0200-9999-F1(TOP)

0200-9999-F2(BOTTOM)

PACKING QUANTITY : 40 PCS FINISHED GOODS PER TRAY

10 TRAYS (400 PCS FINISHED GOODS) PER CARTON BOX

NOTER: CARDBOARDS ARE PLACED BETWEEN LAYERS OF PACKING TRAY INSIDE CARTON BOX (INCLUDE THE UPPERMOST AND LOWERMOST TRAY)

REV. : F PAGE : 6

ORIGINATED BY
ANTON LIAO
DATE 2018-03-24
DRAWN BY
JESSE LI
DATE 2018-03-24

TITLE
10/100 MagJack®
PoE
0813-1X1T-57-F

PART NO. / DRAWING NO.
08131X1T57-F
FILE NAME
08131X1T57-F_F.DWG

STANDARD DIM. TOL. IN INCH		[] METRIC DIM. AS REF.
.X		UNIT : INCH [mm]
.XX		SCALE : N/A
.XXX	±0.005	SIZE : A4



Looking for pricing, stock, or lifecycle information?

Click below to explore more details on WIN SOURCE:

[View 0813-1X1T-57-F on WIN SOURCE](#)

[Bel Fuse Inc. Information](#)

Optimize Your Supply Chain with WIN SOURCE Solutions

- ✓ Global Sourcing Solution
- ✓ Obsolete Management
- ✓ Cost Control Management
- ✓ Shortage Management
- ✓ Alternative Solution
- ✓ Excess Inventory Management