



**THE DATASHEET OF  
CY7C1061GN30-10ZSXIT**



**16-Mbit (1 M words × 16 bit) Static RAM**

**Features**

- High speed
  - $t_{AA} = 10 \text{ ns}$
- Low active power
  - $I_{CC} = 90 \text{ mA}$  at 100 MHz
- Low CMOS standby current
  - $I_{SB2} = 20 \text{ mA}$  (typ)
- Operating voltages of 2.2 V to 3.6 V
- 1.0 V data retention
- Automatic power down when deselected
- TTL compatible inputs and outputs
- Easy memory expansion with  $\overline{CE}_1$  and  $CE_2$  features
- Available in Pb-free 54-pin TSOP II, and 48-ball VFBGA packages
- Offered in dual Chip Enable options

**Functional Description**

The CY7C1061GN30 is a high performance CMOS Static RAM organized as 1,048,576 words by 16 bits.

To write to the device, take Chip Enables ( $\overline{CE}_1$  LOW and  $CE_2$  HIGH) and Write Enable ( $\overline{WE}$ ) input LOW. If Byte Low Enable ( $\overline{BLE}$ ) is LOW, then data from I/O pins ( $I/O_0$  through  $I/O_7$ ), is written into the location specified on the address pins ( $A_0$  through  $A_{19}$ ). If Byte High Enable ( $\overline{BHE}$ ) is LOW, then data from I/O pins ( $I/O_8$  through  $I/O_{15}$ ) is written into the location specified on the address pins ( $A_0$  through  $A_{19}$ ).

To read from the device, take Chip Enables ( $\overline{CE}_1$  LOW and  $CE_2$  HIGH) and Output Enable ( $\overline{OE}$ ) LOW while forcing the Write Enable ( $\overline{WE}$ ) HIGH. If Byte Low Enable ( $\overline{BLE}$ ) is LOW, then data from the memory location specified by the address pins appears on  $I/O_0$  to  $I/O_7$ . If Byte High Enable ( $\overline{BHE}$ ) is LOW, then data from memory appears on  $I/O_8$  to  $I/O_{15}$ . See Truth Table on page 12 for a complete description of Read and Write modes.

The input or output pins ( $I/O_0$  through  $I/O_{15}$ ) are placed in a high impedance state when the device is deselected ( $\overline{CE}_1$  HIGH/ $CE_2$  LOW), the outputs are disabled ( $\overline{OE}$  HIGH), the  $\overline{BHE}$  and  $\overline{BLE}$  are disabled ( $\overline{BHE}$ ,  $\overline{BLE}$  HIGH), or during a write operation ( $\overline{CE}_1$  LOW,  $CE_2$  HIGH, and  $\overline{WE}$  LOW).

**Logic Block Diagram**

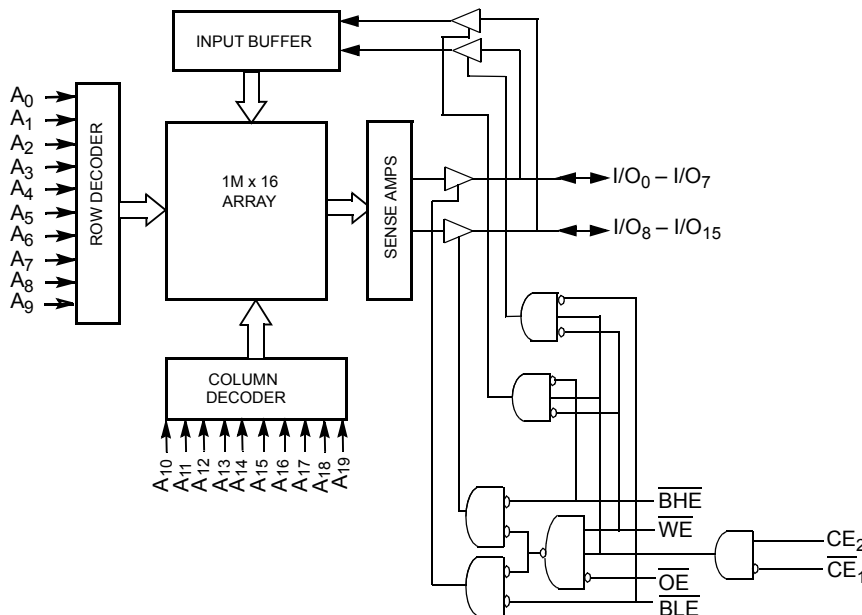

## Contents

<b>Selection Guide</b> .....	<b>3</b>	<b>Ordering Information</b> .....	<b>13</b>
<b>Pin Configurations</b> .....	<b>3</b>	Ordering Code Definitions .....	13
<b>Maximum Ratings</b> .....	<b>5</b>	<b>Package Diagrams</b> .....	<b>14</b>
<b>Operating Range</b> .....	<b>5</b>	<b>Acronyms</b> .....	<b>16</b>
<b>DC Electrical Characteristics</b> .....	<b>5</b>	<b>Document Conventions</b> .....	<b>16</b>
<b>Capacitance</b> .....	<b>6</b>	Units of Measure .....	16
<b>Thermal Resistance</b> .....	<b>6</b>	<b>Document History Page</b> .....	<b>17</b>
<b>AC Test Loads and Waveforms</b> .....	<b>6</b>	<b>Sales, Solutions, and Legal Information</b> .....	<b>18</b>
<b>Data Retention Characteristics</b> .....	<b>7</b>	Worldwide Sales and Design Support .....	18
<b>Over the Operating Range</b> .....	<b>7</b>	Products .....	18
<b>Data Retention Waveform</b> .....	<b>7</b>	PSoC® Solutions .....	18
<b>AC Switching Characteristics</b> .....	<b>8</b>	Cypress Developer Community .....	18
<b>Switching Waveforms</b> .....	<b>9</b>	Technical Support .....	18
<b>Truth Table</b> .....	<b>12</b>		

**Selection Guide**

Description	-10	Unit
Maximum access time	10	ns
Maximum operating current	110	mA
Maximum CMOS standby current	30	mA

**Pin Configurations**

**Figure 1. 48-ball VFBGA (8 × 9.5 × 1 mm) Dual Chip Enable pinout (Top View) <sup>[1]</sup>**

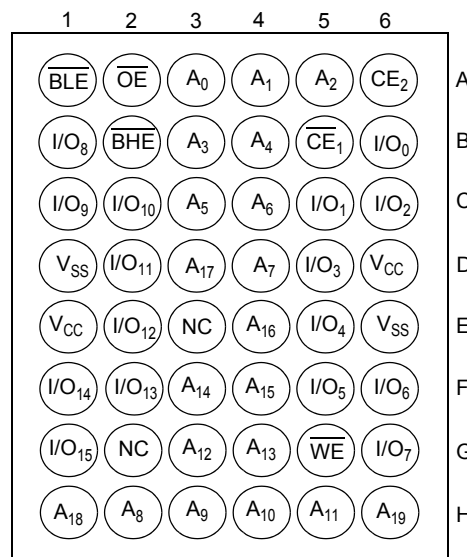

**Note**

1. NC pins are not connected internally to the die.

Pin Configurations (continued)

Figure 2. 54-pin TSOP II (22.4 × 11.84 × 1.0 mm) pinout (Top View) [2]

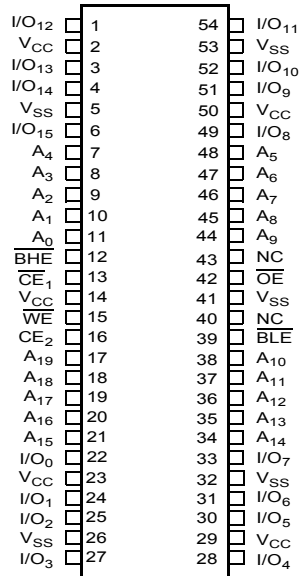

Note

- NC pins are not connected internally to the die.

## Maximum Ratings

Exceeding maximum ratings may impair the useful life of the device. These user guidelines are not tested.

Storage Temperature .....	-65 °C to +150 °C
Ambient Temperature with Power Applied .....	-55 °C to +125 °C
Supply Voltage on V <sub>CC</sub> relative to GND [3] .....	-0.5 V to V <sub>CC</sub> + 0.5 V
DC Voltage Applied to Outputs in High Z State [3] .....	-0.5 V to V <sub>CC</sub> + 0.5 V

DC Input Voltage [3] .....	-0.5 V to V <sub>CC</sub> + 0.5 V
Current into Outputs (LOW) .....	20 mA
Static Discharge Voltage (MIL-STD-883, Method 3015) .....	>2001 V
Latch Up Current .....	>200 mA

## Operating Range

Range	Ambient Temperature	V <sub>CC</sub>
Industrial	-40 °C to +85 °C	2.2 V to 3.6 V

## DC Electrical Characteristics

Over the Operating Range

Parameter	Description	Test Conditions	-10			Unit	
			Min	Typ [4]	Max		
V <sub>OH</sub>	Output HIGH voltage	2.2 V to 2.7 V	V <sub>CC</sub> = Min, I <sub>OH</sub> = -0.1 mA	2.0	-	-	V
		2.7 V to 3.6 V	V <sub>CC</sub> = Min, I <sub>OH</sub> = -4.0 mA	2.2	-	-	
V <sub>OL</sub>	Output LOW voltage	2.2 V to 2.7 V	V <sub>CC</sub> = Min, I <sub>OL</sub> = 2 mA	-	-	0.4	V
		2.7 V to 3.6 V	V <sub>CC</sub> = Min, I <sub>OL</sub> = 8 mA	-	-	0.4	
V <sub>IH</sub>	Input HIGH voltage [3]	2.2 V to 2.7 V	-	2.0	-	V <sub>CC</sub> + 0.3	V
		2.7 V to 3.6 V	-	2.0	-	V <sub>CC</sub> + 0.3	
V <sub>IL</sub>	Input LOW voltage [3]	2.2 V to 2.7 V	-	-0.3	-	0.6	V
		2.7 V to 3.6 V	-	-0.3	-	0.8	
I <sub>IX</sub>	Input leakage current	GND ≤ V <sub>I</sub> ≤ V <sub>CC</sub>	-1	-	+1	μA	
I <sub>OZ</sub>	Output leakage current	GND ≤ V <sub>OUT</sub> ≤ V <sub>CC</sub> , Output disabled	-1	-	+1	μA	
I <sub>CC</sub>	V <sub>CC</sub> operating supply current	V <sub>CC</sub> = Max, f = f <sub>MAX</sub> = 1/t <sub>RC</sub> , I <sub>OUT</sub> = 0 mA, CMOS levels	-	90	110	mA	
I <sub>SB1</sub>	Automatic CE power down current – TTL inputs	Max V <sub>CC</sub> , $\overline{CE}_1 \geq V_{IH}$ , CE <sub>2</sub> ≤ V <sub>IL</sub> , V <sub>IN</sub> ≥ V <sub>IH</sub> or V <sub>IN</sub> ≤ V <sub>IL</sub> , f = f <sub>MAX</sub>	-	-	40	mA	
I <sub>SB2</sub>	Automatic CE power down current – CMOS inputs	Max V <sub>CC</sub> , $\overline{CE}_1 \geq V_{CC} - 0.3$ V, CE <sub>2</sub> ≤ 0.3 V, V <sub>IN</sub> ≥ V <sub>CC</sub> - 0.3 V or V <sub>IN</sub> ≤ 0.3 V, f = 0	-	20	30	mA	

### Note

- V<sub>IL(min)</sub> = -2.0 V and V<sub>IH(max)</sub> = V<sub>CC</sub> + 2 V for pulse durations of less than 2 ns.
- Typical values are included only for reference and are not guaranteed or tested. Typical values are measured at V<sub>CC</sub> = 3 V (for a V<sub>CC</sub> range of 2.2 V–3.6 V), T<sub>A</sub> = 25 °C.

### Capacitance

Parameter <sup>[5]</sup>	Description	Test Conditions	54-pin TSOP II	48-ball VFBGA	Unit
C <sub>IN</sub>	Input capacitance	T <sub>A</sub> = 25 °C, f = 1 MHz, V <sub>CC</sub> = 3.3 V	10	10	pF
C <sub>OUT</sub>	I/O capacitance		10	10	pF

### Thermal Resistance

Parameter <sup>[5]</sup>	Description	Test Conditions	54-pin TSOP II	48-ball VFBGA	Unit
Θ <sub>JA</sub>	Thermal resistance (junction to ambient)	Still air, soldered on a 3 × 4.5 inch, four layer printed circuit board	93.63	31.50	°C/W
Θ <sub>JC</sub>	Thermal resistance (junction to case)		21.58	15.75	°C/W

### AC Test Loads and Waveforms

Figure 3. AC Test Loads and Waveforms <sup>[6]</sup>

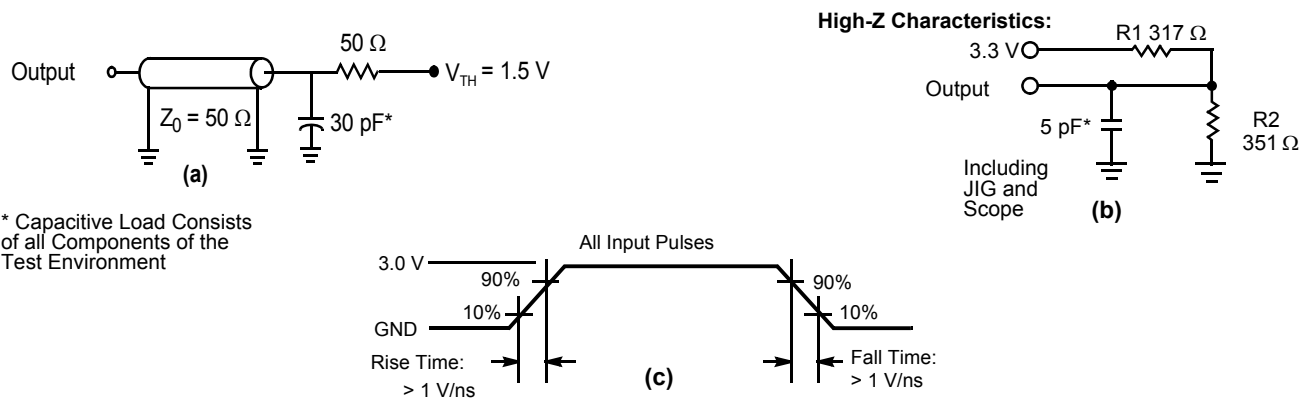

\* Capacitive Load Consists of all Components of the Test Environment

#### Notes

- Tested initially and after any design or process changes that may affect these parameters.
- Valid SRAM operation does not occur until the power supplies have reached the minimum operating V<sub>DD</sub> (3.0 V). 100 μs (t<sub>power</sub>) after reaching the minimum operating V<sub>DD</sub>, normal SRAM operation begins including reduction in V<sub>DD</sub> to the data retention (V<sub>CCDR</sub>, 1.0 V) voltage.

## Data Retention Characteristics

Over the Operating Range

Parameter	Description	Conditions	Min	Max	Unit
$V_{DR}$	$V_{CC}$ for data retention	–	1	–	V
$I_{CCDR}$	Data retention current	$V_{CC} = 1.2\text{ V}$ , $\overline{CE}_1 \geq V_{CC} - 0.2\text{ V}$ , $CE_2 \leq 0.2\text{ V}$ , $V_{IN} \geq V_{CC} - 0.2\text{ V}$ or $V_{IN} \leq 0.2\text{ V}$	–	30	mA
$t_{CDR}^{[7]}$	Chip deselect to data retention time	–	0	–	ns
$t_R^{[8]}$	Operation recovery time	–	10	–	ns

## Data Retention Waveform

Figure 4. Data Retention Waveform <sup>[9]</sup>

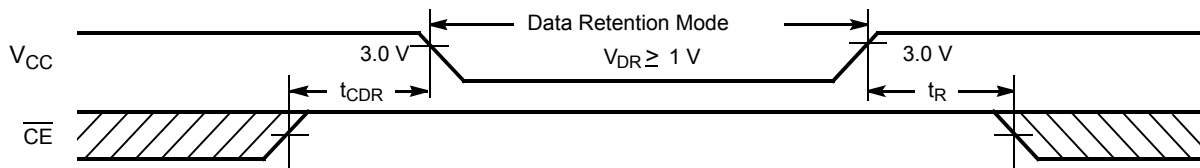

### Notes

7. Tested initially and after any design or process changes that may affect these parameters.
8. Full device operation requires linear  $V_{CC}$  ramp from  $V_{DR}$  to  $V_{CC(min.)} \geq 100\ \mu\text{s}$  or stable at  $V_{CC(min.)} \geq 100\ \mu\text{s}$ .
9.  $\overline{CE}$  is the logical combination of  $\overline{CE}_1$  and  $CE_2$ . When  $\overline{CE}_1$  is LOW and  $CE_2$  is HIGH,  $\overline{CE}$  is LOW; when  $\overline{CE}_1$  is HIGH or  $CE_2$  is LOW,  $\overline{CE}$  is HIGH.

## AC Switching Characteristics

Over the Operating Range

Parameter <sup>[10]</sup>	Description	-10		Unit
		Min	Max	
<b>Read Cycle</b>				
$t_{power}$	$V_{CC}$ (typical) to the first access <sup>[11]</sup>	100	–	$\mu$ s
$t_{RC}$	Read cycle time	10	–	ns
$t_{AA}$	Address to data valid	–	10	ns
$t_{OHA}$	Data hold from address change	3	–	ns
$t_{ACE}$	$\overline{CE}_1$ LOW/ $CE_2$ HIGH to data valid	–	10	ns
$t_{DOE}$	$\overline{OE}$ LOW to data valid	–	5	ns
$t_{LZOE}$	$\overline{OE}$ LOW to low Z <sup>[12]</sup>	0	–	ns
$t_{HZOE}$	$\overline{OE}$ HIGH to high Z <sup>[12]</sup>	–	5	ns
$t_{LZCE}$	$\overline{CE}_1$ LOW/ $CE_2$ HIGH to low Z <sup>[12]</sup>	3	–	ns
$t_{HZCE}$	$\overline{CE}_1$ HIGH/ $CE_2$ LOW to high Z <sup>[12]</sup>	–	5	ns
$t_{PU}$	$\overline{CE}_1$ LOW/ $CE_2$ HIGH to power-up <sup>[13]</sup>	0	–	ns
$t_{PD}$	$\overline{CE}_1$ HIGH/ $CE_2$ LOW to power-down <sup>[13]</sup>	–	10	ns
$t_{DBE}$	Byte enable to data valid	–	5	ns
$t_{LZBE}$	Byte enable to low Z	0	–	ns
$t_{HZBE}$	Byte disable to high Z	–	6	ns
<b>Write Cycle</b> <sup>[14, 15]</sup>				
$t_{WC}$	Write cycle time	10	–	ns
$t_{SCE}$	$\overline{CE}_1$ LOW/ $CE_2$ HIGH to write end	7	–	ns
$t_{AW}$	Address setup to write end	7	–	ns
$t_{HA}$	Address hold from write end	0	–	ns
$t_{SA}$	Address setup to write start	0	–	ns
$t_{PWE}$	$\overline{WE}$ pulse width	7	–	ns
$t_{SD}$	Data setup to write end	5	–	ns
$t_{HD}$	Data hold from write end	0	–	ns
$t_{LZWE}$	$\overline{WE}$ HIGH to low Z <sup>[12,13]</sup>	3	–	ns
$t_{HZWE}$	$\overline{WE}$ LOW to high Z <sup>[12,13]</sup>	–	5	ns
$t_{BW}$	Byte Enable to End of Write	7	–	ns

### Notes

10. Test conditions assume signal transition time of 3 ns or less, timing reference levels of 1.5 V, and input pulse levels of 0 to 3.0 V. Test conditions for the read cycle use output loading shown in part (a) of [Figure 3 on page 6](#), unless specified otherwise.
11.  $t_{POWER}$  gives the minimum amount of time that the power supply is at typical  $V_{CC}$  values until the first memory access is performed.
12.  $t_{HZOE}$ ,  $t_{HZCE}$ ,  $t_{HZWE}$ ,  $t_{HZBE}$ ,  $t_{LZOE}$ ,  $t_{LZCE}$ ,  $t_{LZWE}$ , and  $t_{LZBE}$  are specified with a load capacitance of 5 pF as in (b) of [Figure 3 on page 6](#). Transition is measured when output goes into high impedance.
13. These parameters are guaranteed by design and are not tested.
14. The internal write time of the memory is defined by the overlap of  $\overline{WE}$ ,  $\overline{CE}_1 = V_{IL}$ , and  $CE_2 = V_{IH}$ . Chip enables must be active and  $\overline{WE}$  and byte enables must be LOW to initiate a write, and the transition of any of these signals can terminate. The input data setup and hold timing should be referenced to the edge of the signal that terminates the write.
15. The minimum write cycle time for Write Cycle No. 2 ( $\overline{WE}$  Controlled,  $\overline{OE}$  LOW) is the sum of  $t_{HZWE}$  and  $t_{SD}$ .

### Switching Waveforms

Figure 5. Read Cycle No. 1 (Address Transition Controlled) [16, 17]

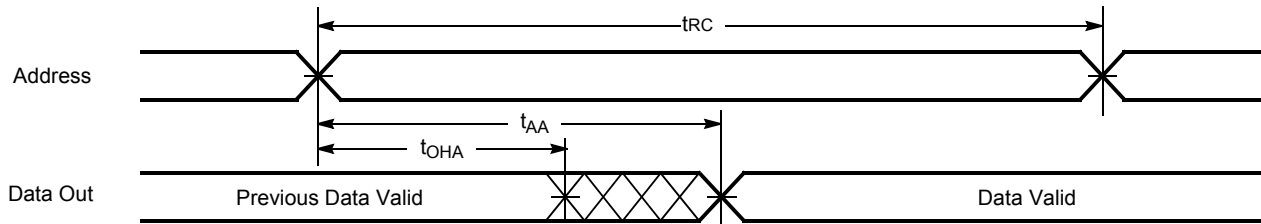
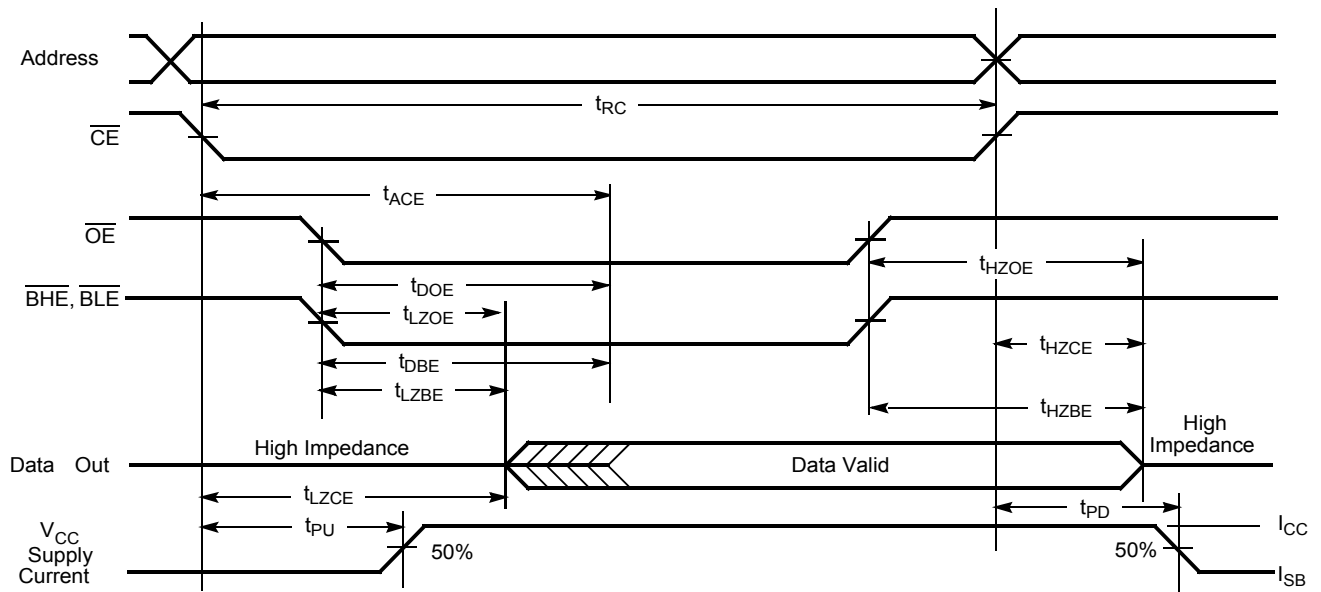

Figure 6. Read Cycle No. 2 ( $\overline{OE}$  Controlled) [17, 18, 19]



**Notes**

16. The device is continuously selected.  $\overline{OE}$ ,  $\overline{CE} = V_{IL}$ ,  $\overline{BHE}$ ,  $\overline{BLE}$  or both =  $V_{IL}$ .

17.  $\overline{WE}$  is HIGH for read cycle.

18.  $\overline{CE}$  is the logical combination of  $\overline{CE}_1$  and  $CE_2$ . When  $\overline{CE}_1$  is LOW and  $CE_2$  is HIGH,  $\overline{CE}$  is LOW; when  $\overline{CE}_1$  is HIGH or  $CE_2$  is LOW,  $\overline{CE}$  is HIGH.

19. Address valid before or similar to  $\overline{CE}$  transition LOW.

Switching Waveforms (continued)

Figure 7. Write Cycle No. 1 ( $\overline{\text{CE}}$  Controlled) [20, 21, 22]

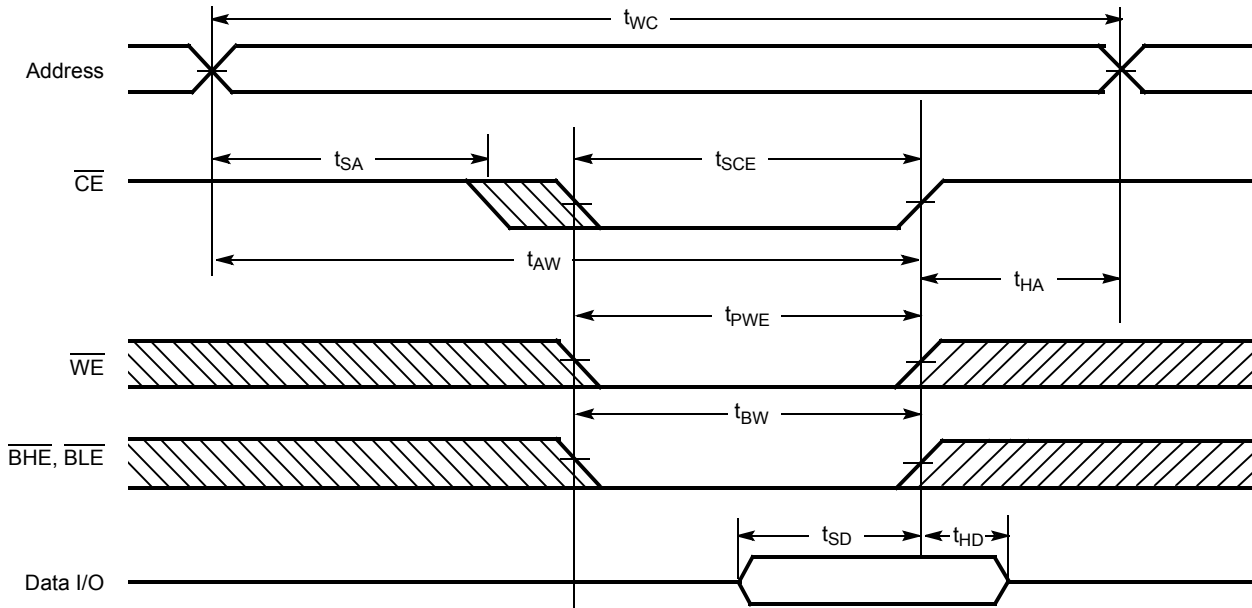
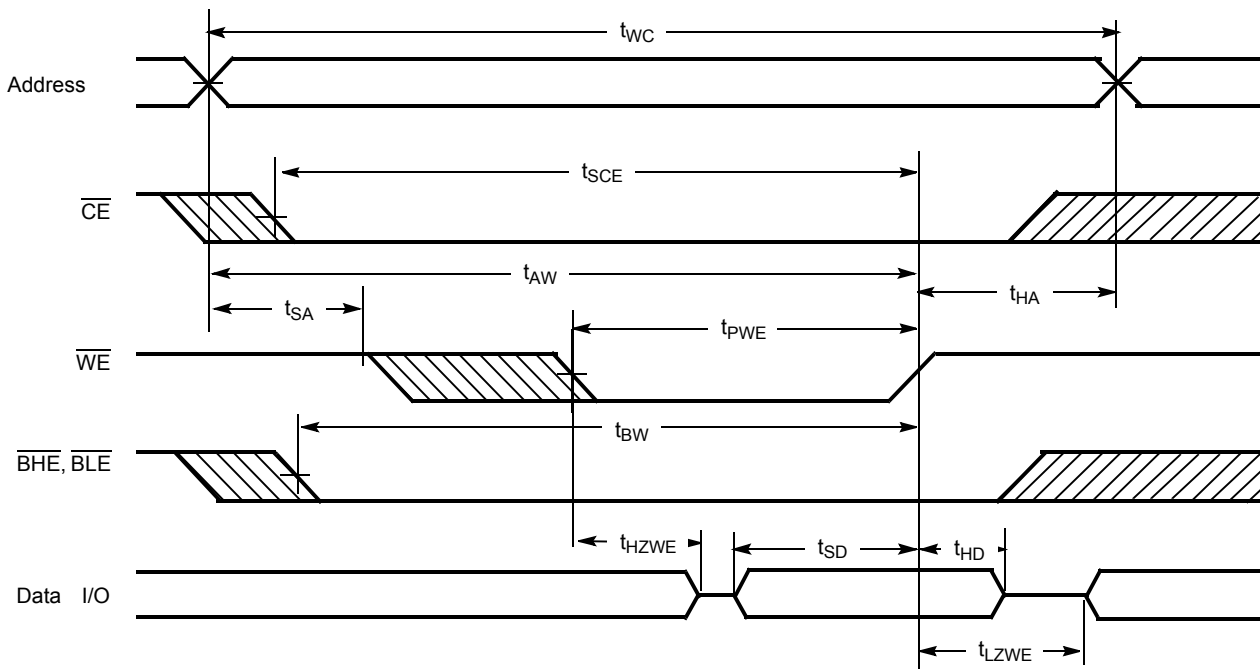

Figure 8. Write Cycle No. 2 ( $\overline{\text{WE}}$  Controlled,  $\overline{\text{OE}}$  LOW) [20, 21, 22]



Notes

20.  $\overline{\text{CE}}$  is the logical combination of  $\overline{\text{CE}}_1$  and  $\text{CE}_2$ . When  $\overline{\text{CE}}_1$  is LOW and  $\text{CE}_2$  is HIGH,  $\overline{\text{CE}}$  is LOW; when  $\overline{\text{CE}}_1$  is HIGH or  $\text{CE}_2$  is LOW,  $\overline{\text{CE}}$  is HIGH.

21. Data I/O is high impedance if  $\overline{\text{OE}}$ ,  $\overline{\text{BHE}}$ , and/or  $\overline{\text{BLE}} = V_{IH}$ .

22. If  $\overline{\text{CE}}$  goes HIGH simultaneously with  $\overline{\text{WE}}$  going HIGH, the output remains in a high-impedance state.

**Switching Waveforms** (continued)

**Figure 9. Write Cycle No. 3 ( $\overline{\text{BLE}}$  or  $\overline{\text{BHE}}$  Controlled) [23]**

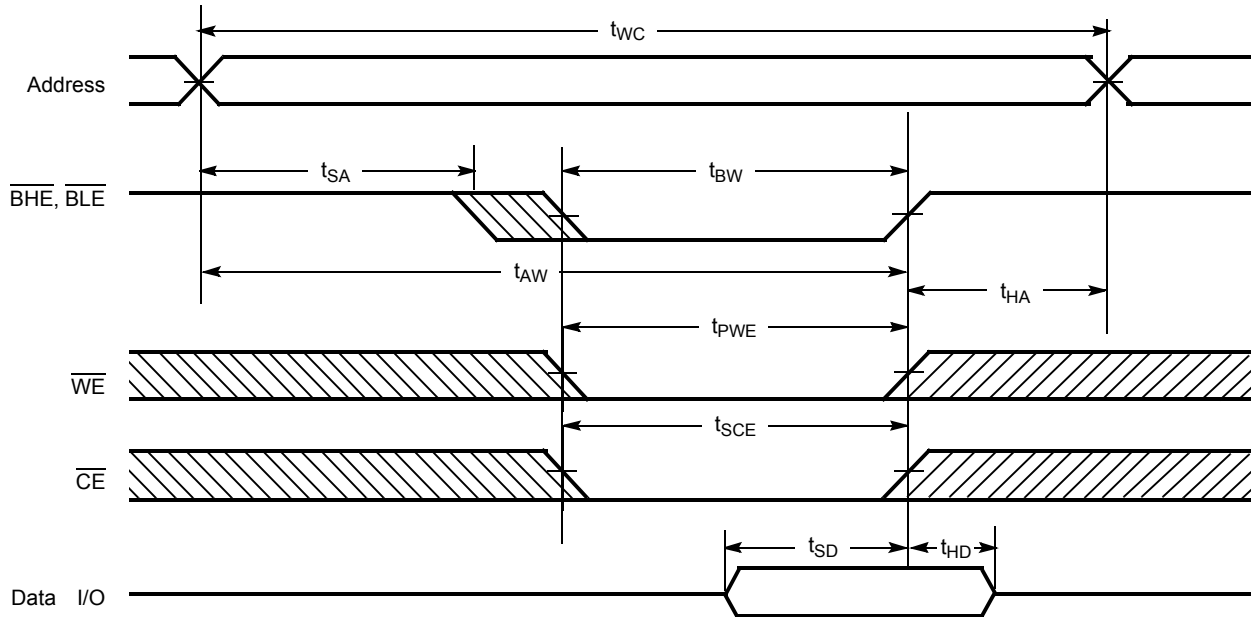

**Note**

23.  $\overline{\text{CE}}$  is the logical combination of  $\overline{\text{CE}}_1$  and  $\text{CE}_2$ . When  $\overline{\text{CE}}_1$  is LOW and  $\text{CE}_2$  is HIGH,  $\overline{\text{CE}}$  is LOW; when  $\overline{\text{CE}}_1$  is HIGH or  $\text{CE}_2$  is LOW,  $\overline{\text{CE}}$  is HIGH.

**Truth Table**

$\overline{CE}_1$	$CE_2$	$\overline{OE}$	$\overline{WE}$	$\overline{BLE}$	$\overline{BHE}$	I/O <sub>0</sub> -I/O <sub>7</sub>	I/O <sub>8</sub> -I/O <sub>15</sub>	Mode	Power
H	X	X	X	X	X	High Z	High Z	Power down	Standby (I <sub>SB</sub> )
X	L	X	X	X	X	High Z	High Z	Power down	Standby (I <sub>SB</sub> )
L	H	L	H	L	L	Data out	Data out	Read all bits	Active (I <sub>CC</sub> )
L	H	L	H	L	H	Data out	High Z	Read lower bits only	Active (I <sub>CC</sub> )
L	H	L	H	H	L	High Z	Data out	Read upper bits only	Active (I <sub>CC</sub> )
L	H	X	L	L	L	Data in	Data in	Write all bits	Active (I <sub>CC</sub> )
L	H	X	L	L	H	Data in	High Z	Write lower bits only	Active (I <sub>CC</sub> )
L	H	X	L	H	L	High Z	Data in	Write upper bits only	Active (I <sub>CC</sub> )
L	H	H	H	X	X	High Z	High Z	Selected, outputs disabled	Active (I <sub>CC</sub> )

**Ordering Information**

Speed (ns)	Ordering Code	Package Diagram	Package Type	Operating Range
10	CY7C1061GN30-10ZSXI	51-85160	54-pin TSOP II (22.4 × 11.84 × 1.0 mm) (Pb-free)	Industrial
	CY7C1061GN30-10BVXI	51-85150	48-ball VFBGA (6 × 8 × 1.0 mm) (Pb-free) (Dual Chip Enable)	

**Ordering Code Definitions**

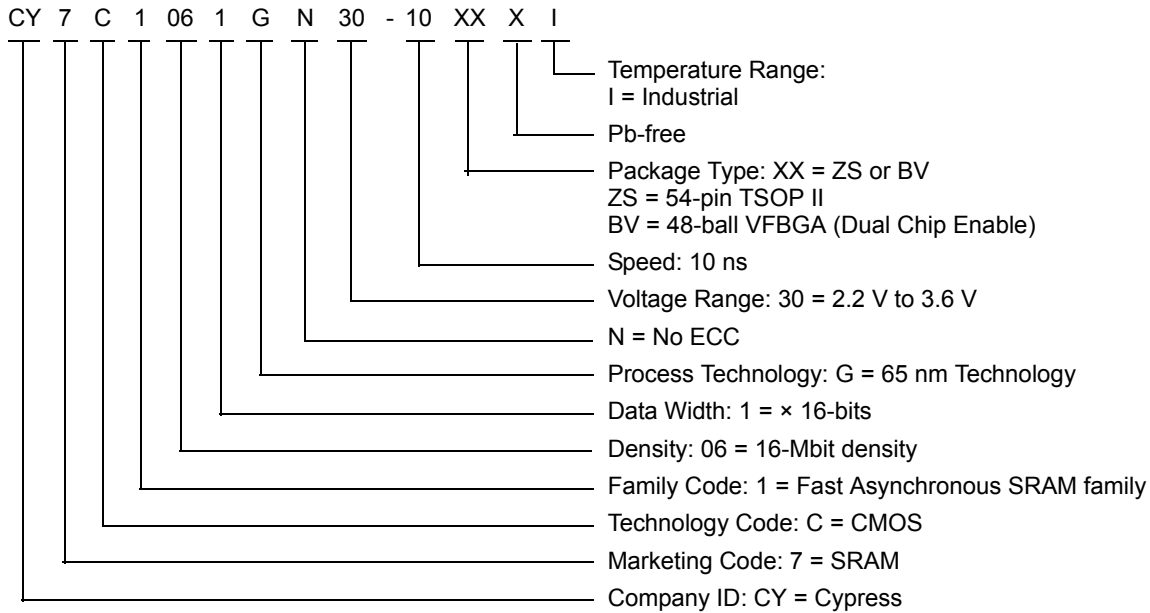

Package Diagrams

Figure 10. 54-pin TSOP II (22.4 × 11.84 × 1.0 mm) Z54-II Package Outline, 51-85160

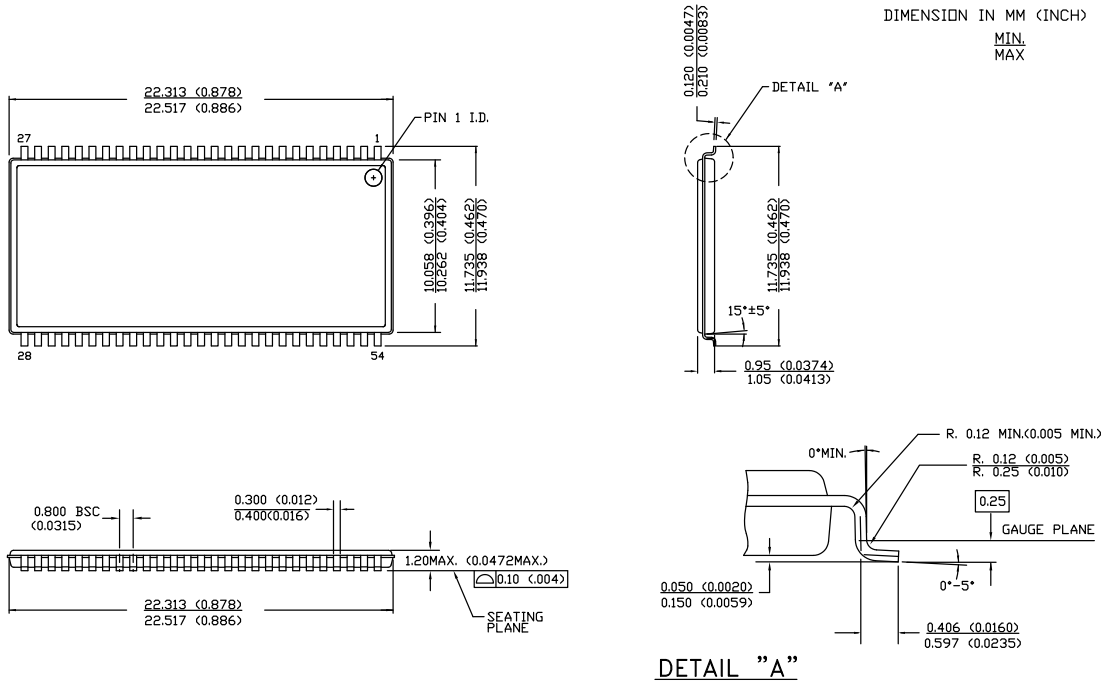

51-85160 \*E

Package Diagrams (continued)

Figure 11. 48-ball VFBGA (6 × 8 × 1.0 mm) BV48/BZ48 Package Outline, 51-85150

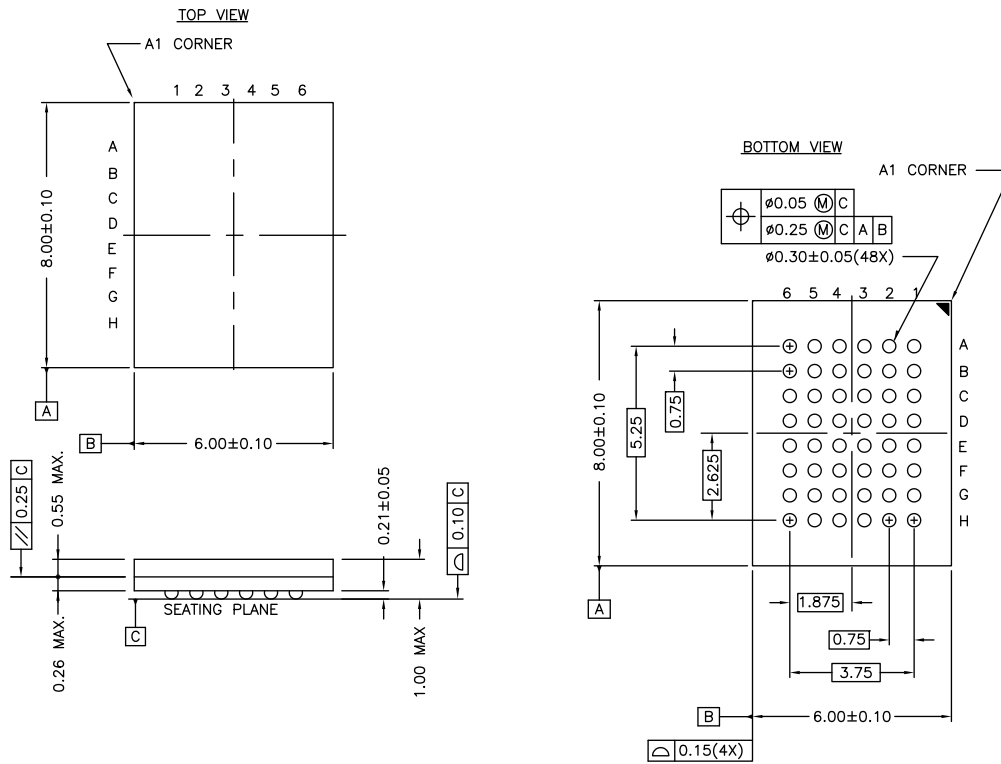

NOTE:  
 PACKAGE WEIGHT: See Cypress Package Material Declaration Datasheet (PMDD) posted on the Cypress web.

51-85150 \*H

## Acronyms

Acronym	Description
$\overline{\text{BHE}}$	Byte High Enable
$\overline{\text{BLE}}$	Byte Low Enable
$\overline{\text{CE}}$	Chip Enable
CMOS	Complementary Metal Oxide Semiconductor
I/O	Input/Output
$\overline{\text{OE}}$	Output Enable
SRAM	Static Random Access Memory
TSOP	Thin Small Outline Package
TTL	Transistor-Transistor Logic
VFBGA	Very Fine-Pitch Ball Grid Array
$\overline{\text{WE}}$	Write Enable

## Document Conventions

### Units of Measure

Symbol	Unit of Measure
$^{\circ}\text{C}$	degree Celsius
MHz	megahertz
$\mu\text{A}$	microampere
$\mu\text{s}$	microsecond
mA	milliampere
mm	millimeter
ns	nanosecond
$\Omega$	ohm
%	percent
pF	picofarad
V	volt
W	watt

## Document History Page

Document Title: CY7C1061GN30, 16-Mbit (1 M words × 16 bit) Static RAM Document Number: 001-93680				
Rev.	ECN No.	Orig. of Change	Submission Date	Description of Change
**	4505531	VINI	01/02/2015	New data sheet.
*A	4900408	NILE	09/11/2015	Updated <a href="#">DC Electrical Characteristics</a> : Updated details in "Test Conditions" column of V <sub>OH</sub> and V <sub>OL</sub> parameters. Updated <a href="#">Ordering Information</a> : No change in part numbers. Replaced "51-85178" with "51-85150" in "Package Diagram" column. Replaced "8 × 9.5 × 1 mm" with "6 × 8 × 1.0 mm" in "Package Type" column. Updated <a href="#">Package Diagrams</a> : Removed spec 51-85178 *C. Added spec 51-85150 *H. Updated to new template.

## Sales, Solutions, and Legal Information

### Worldwide Sales and Design Support

Cypress maintains a worldwide network of offices, solution centers, manufacturer's representatives, and distributors. To find the office closest to you, visit us at [Cypress Locations](#).

#### Products

<a href="#">Automotive</a>	<a href="#">cypress.com/go/automotive</a>
<a href="#">Clocks &amp; Buffers</a>	<a href="#">cypress.com/go/clocks</a>
<a href="#">Interface</a>	<a href="#">cypress.com/go/interface</a>
<a href="#">Lighting &amp; Power Control</a>	<a href="#">cypress.com/go/powerpsoc</a>
<a href="#">Memory</a>	<a href="#">cypress.com/go/memory</a>
<a href="#">PSoC</a>	<a href="#">cypress.com/go/psoc</a>
<a href="#">Touch Sensing</a>	<a href="#">cypress.com/go/touch</a>
<a href="#">USB Controllers</a>	<a href="#">cypress.com/go/USB</a>
<a href="#">Wireless/RF</a>	<a href="#">cypress.com/go/wireless</a>

#### PSoC<sup>®</sup> Solutions

[psoc.cypress.com/solutions](#)  
[PSoC 1](#) | [PSoC 3](#) | [PSoC 4](#) | [PSoC 5LP](#)

#### Cypress Developer Community

[Community](#) | [Forums](#) | [Blogs](#) | [Video](#) | [Training](#)

#### Technical Support

[cypress.com/go/support](#)

---

© Cypress Semiconductor Corporation, 2015. The information contained herein is subject to change without notice. Cypress Semiconductor Corporation assumes no responsibility for the use of any circuitry other than circuitry embodied in a Cypress product. Nor does it convey or imply any license under patent or other rights. Cypress products are not warranted nor intended to be used for medical, life support, life saving, critical control or safety applications, unless pursuant to an express written agreement with Cypress. Furthermore, Cypress does not authorize its products for use as critical components in life-support systems where a malfunction or failure may reasonably be expected to result in significant injury to the user. The inclusion of Cypress products in life-support systems application implies that the manufacturer assumes all risk of such use and in doing so indemnifies Cypress against all charges.

Any Source Code (software and/or firmware) is owned by Cypress Semiconductor Corporation (Cypress) and is protected by and subject to worldwide patent protection (United States and foreign), United States copyright laws and international treaty provisions. Cypress hereby grants to licensee a personal, non-exclusive, non-transferable license to copy, use, modify, create derivative works of, and compile the Cypress Source Code and derivative works for the sole purpose of creating custom software and or firmware in support of licensee product to be used only in conjunction with a Cypress integrated circuit as specified in the applicable agreement. Any reproduction, modification, translation, compilation, or representation of this Source Code except as specified above is prohibited without the express written permission of Cypress.

Disclaimer: CYPRESS MAKES NO WARRANTY OF ANY KIND, EXPRESS OR IMPLIED, WITH REGARD TO THIS MATERIAL, INCLUDING, BUT NOT LIMITED TO, THE IMPLIED WARRANTIES OF MERCHANTABILITY AND FITNESS FOR A PARTICULAR PURPOSE. Cypress reserves the right to make changes without further notice to the materials described herein. Cypress does not assume any liability arising out of the application or use of any product or circuit described herein. Cypress does not authorize its products for use as critical components in life-support systems where a malfunction or failure may reasonably be expected to result in significant injury to the user. The inclusion of Cypress' product in a life-support systems application implies that the manufacturer assumes all risk of such use and in doing so indemnifies Cypress against all charges.

Use may be limited by and subject to the applicable Cypress software license agreement.

## Looking for pricing, stock, or lifecycle information?

Click below to explore more details on WIN SOURCE:

 [View CY7C1061GN30-10ZSXIT on WIN SOURCE](#)

 [Infineon Technologies](#) Information

## Optimize Your Supply Chain with WIN SOURCE Solutions

-  Global Sourcing Solution
-  Obsolete Management
-  Cost Control Management
-  Shortage Management
-  Alternative Solution
-  Excess Inventory Management