



**THE DATASHEET OF  
CY62167EV30LL-45BVXIT**



# 16-Mbit (1M × 16/2M × 8) Static RAM

## Features

- TSOP I package configurable as 1M × 16 or 2M × 8 SRAM
- Very high speed: 45 ns
- Temperature ranges
  - Automotive-A: -40 °C to +85 °C
- Wide voltage range: 2.20 V to 3.60 V
- Ultra-low standby power
  - Typical standby current: 1.5 μA
  - Maximum standby current: 12 μA
- Ultra-low active power
  - Typical active current: 2.2 mA at f = 1 MHz
- Easy memory expansion with  $\overline{CE}_1$ ,  $CE_2$ , and  $\overline{OE}$  Features
- Automatic power-down when deselected
- CMOS for optimum speed and power
- Offered in Pb-free 48-ball VFPGA and 48-pin TSOP I packages

## Functional Description

The CY62167EV30 is a high-performance CMOS static RAM organized as 1M words by 16 bits or 2M words by 8 bits. This device features an advanced circuit design that provides an ultra low active current. Ultra low active current is ideal for providing

More Battery Life™ (MoBL®) in portable applications such as cellular telephones. The device also has an automatic power down feature that reduces power consumption by 99 percent when addresses are not toggling. Place the device in standby mode when deselected ( $\overline{CE}_1$  HIGH or  $CE_2$  LOW or both BHE and BLE are HIGH). The input and output pins (I/O<sub>0</sub> through I/O<sub>15</sub>) are placed in a high-impedance state when: the device is deselected ( $\overline{CE}_1$  HIGH or  $CE_2$  LOW), outputs are disabled ( $\overline{OE}$  HIGH), both Byte High Enable and Byte Low Enable are disabled (BHE, BLE HIGH), or a write operation is in progress ( $\overline{CE}_1$  LOW,  $CE_2$  HIGH and WE LOW).

To write to the device, take Chip Enables ( $\overline{CE}_1$  LOW and  $CE_2$  HIGH) and Write Enable (WE) input LOW. If Byte Low Enable (BLE) is LOW, then data from I/O pins (I/O<sub>0</sub> through I/O<sub>7</sub>) is written into the location specified on the address pins (A<sub>0</sub> through A<sub>19</sub>). If Byte High Enable (BHE) is LOW, then data from the I/O pins (I/O<sub>8</sub> through I/O<sub>15</sub>) is written into the location specified on the address pins (A<sub>0</sub> through A<sub>19</sub>).

To read from the device, take Chip Enables ( $\overline{CE}_1$  LOW and  $CE_2$  HIGH) and Output Enable ( $\overline{OE}$ ) LOW while forcing the Write Enable (WE) HIGH. If Byte Low Enable (BLE) is LOW, then data from the memory location specified by the address pins appears on I/O<sub>0</sub> to I/O<sub>7</sub>. If Byte High Enable (BHE) is LOW, then data from memory appears on I/O<sub>8</sub> to I/O<sub>15</sub>. See Truth Table on page 12 for a complete description of read and write modes.

For a complete list of related documentation, [click here](#).

## Logic Block Diagram

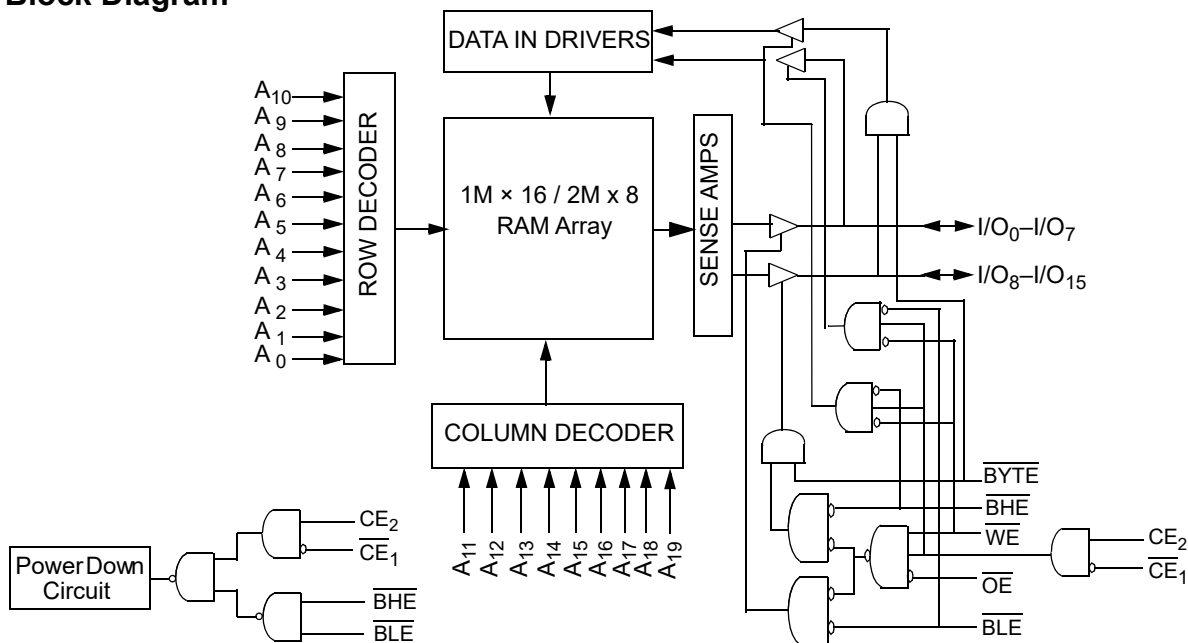

## Contents

<b>Pin Configuration</b> .....	<b>3</b>	<b>Ordering Information</b> .....	<b>13</b>
<b>Product Portfolio</b> .....	<b>3</b>	Ordering Code Definitions .....	13
<b>Maximum Ratings</b> .....	<b>4</b>	<b>Package Diagrams</b> .....	<b>14</b>
<b>Operating Range</b> .....	<b>4</b>	<b>Acronyms</b> .....	<b>16</b>
<b>Electrical Characteristics</b> .....	<b>4</b>	<b>Document Conventions</b> .....	<b>16</b>
<b>Capacitance</b> .....	<b>5</b>	Units of Measure .....	16
<b>Thermal Resistance</b> .....	<b>5</b>	<b>Document History Page</b> .....	<b>17</b>
<b>AC Test Loads and Waveforms</b> .....	<b>5</b>	<b>Sales, Solutions, and Legal Information</b> .....	<b>19</b>
<b>Data Retention Characteristics</b> .....	<b>6</b>	Worldwide Sales and Design Support .....	19
<b>Data Retention Waveform</b> .....	<b>6</b>	Products .....	19
<b>Switching Characteristics</b> .....	<b>7</b>	PSoC® Solutions .....	19
<b>Switching Waveforms</b> .....	<b>8</b>	Cypress Developer Community .....	19
<b>Truth Table</b> .....	<b>12</b>	Technical Support .....	19

## Pin Configuration

Figure 1. 48-ball VFBGA Pinout (Top View) [1, 2]

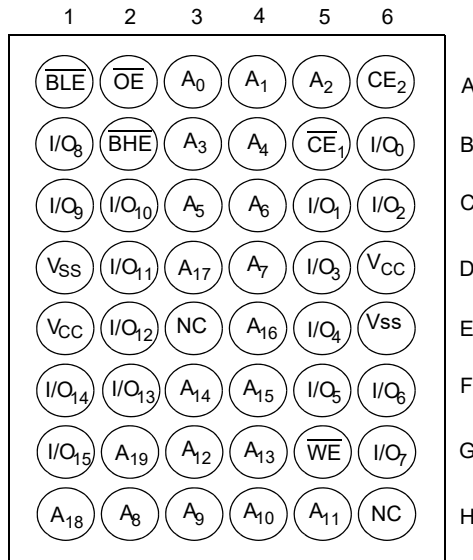
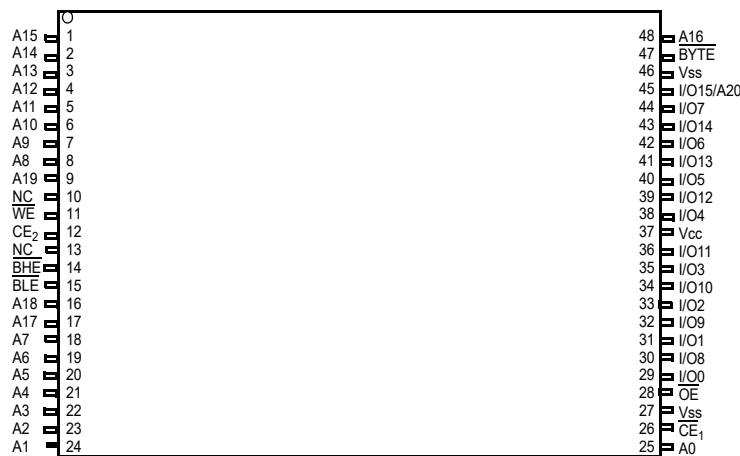

Figure 2. 48-pin TSOP I Pinout (Top View) [2, 3]



## Product Portfolio

Product	Range	V <sub>CC</sub> Range (V)			Speed (ns)	Power Dissipation					
						Operating I <sub>CC</sub> (mA)				Standby I <sub>SB2</sub> (μA)	
		f = 1 MHz		f = f <sub>max</sub>							
		Min	Typ <sup>[4]</sup>	Max		Typ <sup>[4]</sup>	Max	Typ <sup>[4]</sup>	Max	Typ <sup>[4]</sup>	Max
CY62167EV30LL	Automotive-A	2.2	3.0	3.6	45	2.2	4.0	25	30	1.5	12

### Notes

- Ball H6 for the VFBGA package can be used to upgrade to a 32M density.
- NC pins are not connected on the die.
- The BYTE pin in the 48-pin TSOP I package has to be tied to V<sub>CC</sub> to use the device as a 1 M × 16 SRAM. The 48-pin TSOP I package can also be used as a 2 M × 8 SRAM by tying the BYTE signal to V<sub>SS</sub>. In the 2 M × 8 configuration, Pin 45 is A20, while BHE, BLE, and I/O<sub>8</sub> to I/O<sub>14</sub> pins are not used.
- Typical values are included for reference only and are not guaranteed or tested. Typical values are measured at V<sub>CC</sub> = V<sub>CC(typ)</sub>, T<sub>A</sub> = 25 °C.

## Maximum Ratings

Exceeding maximum ratings may shorten the useful life of the device. User guidelines are not tested.

Storage temperature .....	-65 °C to + 150 °C
Ambient temperature with power applied .....	-55 °C to + 125 °C
Supply voltage to ground potential [5, 6] .....	-0.3 V to 3.9 V ( $V_{CC(max)}$ + 0.3 V)
DC voltage applied to outputs in High Z state [5, 6] .....	-0.3 V to 3.9 V ( $V_{CC(max)}$ + 0.3 V)

DC input voltage [5, 6] .....	-0.3 V to 3.9 V ( $V_{CC(max)}$ + 0.3 V)
Output current into outputs (LOW) .....	20 mA
Static discharge voltage (MIL-STD-883, Method 3015) .....	>2001 V
Latch-up current .....	>200 mA

## Operating Range

Device	Range	Ambient Temperature	V <sub>CC</sub> [7]
CY62167EV30LL	Automotive-A	-40 °C to +85 °C	2.2 V to 3.6 V

## Electrical Characteristics

Over the Operating Range

Parameter	Description	Test Conditions	45 ns (Automotive-A)			Unit	
			Min	Typ [8]	Max		
V <sub>OH</sub>	Output HIGH voltage	2.2 ≤ V <sub>CC</sub> ≤ 2.7	I <sub>OH</sub> = -0.1 mA	2.0	-	-	V
		2.7 ≤ V <sub>CC</sub> ≤ 3.6	I <sub>OH</sub> = -1.0 mA	2.4	-	-	V
V <sub>OL</sub>	Output LOW voltage	2.2 ≤ V <sub>CC</sub> ≤ 2.7	I <sub>OL</sub> = 0.1 mA	-	-	0.4	V
		2.7 ≤ V <sub>CC</sub> ≤ 3.6	I <sub>OL</sub> = 2.1 mA	-	-	0.4	V
V <sub>IH</sub>	Input HIGH voltage	2.2 ≤ V <sub>CC</sub> ≤ 2.7		1.8	-	V <sub>CC</sub> + 0.3	V
		2.7 ≤ V <sub>CC</sub> ≤ 3.6		2.2	-	V <sub>CC</sub> + 0.3	V
V <sub>IL</sub>	Input LOW voltage	2.2 ≤ V <sub>CC</sub> ≤ 2.7		-0.3	-	0.6	V
		2.7 ≤ V <sub>CC</sub> ≤ 3.6	For VFPGA package	-0.3	-	0.8	V
			For TSOP I package	-0.3	-	0.7 <sup>[9]</sup>	V
I <sub>IX</sub>	Input leakage current	GND ≤ V <sub>I</sub> ≤ V <sub>CC</sub>		-1	-	+1	μA
I <sub>OZ</sub>	Output leakage current	GND ≤ V <sub>O</sub> ≤ V <sub>CC</sub> , Output disabled		-1	-	+1	μA
I <sub>CC</sub>	V <sub>CC</sub> operating supply current	f = f <sub>max</sub> = 1/t <sub>RC</sub>	V <sub>CC</sub> = V <sub>CC(max)</sub>	-	25	30	mA
		f = 1 MHz	I <sub>OUT</sub> = 0 mA CMOS levels	-	2.2	4.0	mA
I <sub>SB1</sub> <sup>[10]</sup>	Automatic power down current – CMOS inputs	$\overline{CE}_1 \geq V_{CC} - 0.2 \text{ V}$ or $CE_2 \leq 0.2 \text{ V}$ or $(\overline{BHE}$ and $\overline{BLE}) \geq V_{CC} - 0.2 \text{ V}$ , $V_{IN} \geq V_{CC} - 0.2 \text{ V}$ , $V_{IN} \leq 0.2 \text{ V}$ , $f = f_{max}$ (address and data only), $f = 0$ ( $\overline{OE}$ , and $\overline{WE}$ ), $V_{CC} = V_{CC(max)}$		-	1.5	12	μA
I <sub>SB2</sub> <sup>[10]</sup>	Automatic power down current – CMOS inputs	$\overline{CE}_1 \geq V_{CC} - 0.2 \text{ V}$ or $CE_2 \leq 0.2 \text{ V}$ or	V <sub>CC</sub> = V <sub>CC(max)</sub> Temperature = 25 °C	-	1.5	3.0 <sup>[11]</sup>	μA
			$(\overline{BHE}$ and $\overline{BLE}) \geq V_{CC} - 0.2 \text{ V}$ , $V_{IN} \geq V_{CC} - 0.2 \text{ V}$ or $V_{IN} \leq 0.2 \text{ V}$ , f = 0	V <sub>CC</sub> = 3.0 V, Temperature = 40 °C	-	-	
			V <sub>CC</sub> = V <sub>CC(max)</sub> Temperature = 85 °C	-	-	12	

### Notes

- V<sub>IL(min)</sub> = -2.0 V for pulse durations less than 20 ns.
- V<sub>IH(max)</sub> = V<sub>CC</sub> + 0.75 V for pulse durations less than 20 ns.
- Full Device AC operation assumes a 100-μs ramp time from 0 to V<sub>CC(min)</sub> and 200-μs wait time after V<sub>CC</sub> stabilization.
- Typical values are included for reference only and are not guaranteed or tested. Typical values are measured at V<sub>CC</sub> = V<sub>CC(typ)</sub>, T<sub>A</sub> = 25 °C.
- Under DC conditions the device meets a V<sub>IL</sub> of 0.8 V. However, in dynamic conditions Input LOW Voltage applied to the device must not be higher than 0.7 V. This is applicable to the TSOP I package only.
- Chip enables ( $\overline{CE}_1$  and  $CE_2$ ), byte enables ( $\overline{BHE}$  and  $\overline{BLE}$ ) and  $\overline{BYTE}$  must be tied to CMOS levels to meet the I<sub>SB1</sub>/I<sub>SB2</sub> / I<sub>CCDR</sub> spec. Other inputs can be left floating
- This parameter is guaranteed by design.

### Capacitance

Parameter <sup>[12]</sup>	Description	Test Conditions	Max	Unit
C <sub>IN</sub>	Input capacitance	T <sub>A</sub> = 25 °C, f = 1 MHz, V <sub>CC</sub> = V <sub>CC(typ)</sub>	10	pF
C <sub>OUT</sub>	Output capacitance		10	pF

### Thermal Resistance

Parameter <sup>[12]</sup>	Description	Test Conditions	48-ball VFBGA	48-pin TSOP I	Unit
Θ <sub>JA</sub>	Thermal resistance (junction to ambient)	Still air, soldered on a 3 × 4.5 inch, two-layer printed circuit board	55	60	°C/W
Θ <sub>JC</sub>	Thermal resistance (junction to case)		16	4.3	°C/W

### AC Test Loads and Waveforms

Figure 3. AC Test Loads and Waveforms

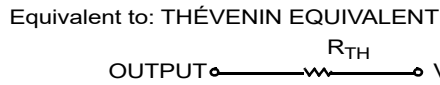
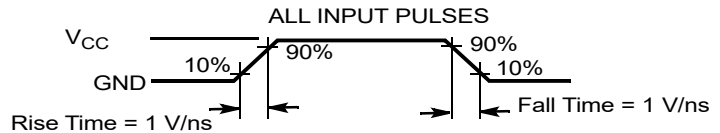
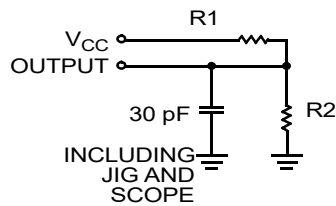

Parameters	2.2 V to 2.7 V	2.7 V to 3.6 V	Unit
R1	16667	1103	Ω
R2	15385	1554	Ω
R <sub>TH</sub>	8000	645	Ω
V <sub>TH</sub>	1.20	1.75	V

**Note**

12. Tested initially and after any design or process changes that may affect these parameters.

## Data Retention Characteristics

Over the Operating Range

Parameter	Description	Conditions			Min	Typ <sup>[13]</sup>	Max	Unit
$V_{DR}$	$V_{CC}$ for data retention				1.5	–	–	V
$I_{CCDR}$ <sup>[14]</sup>	Data retention current	$V_{CC} = 1.5\text{ V to }3.0\text{ V}$ , $\overline{CE}_1 \geq V_{CC} - 0.2\text{ V}$ or $CE_2 \leq 0.2\text{ V}$ or $(\overline{BHE}$ and $\overline{BLE}) \geq V_{CC} - 0.2\text{ V}$ , $V_{IN} \geq V_{CC} - 0.2\text{ V}$ or $V_{IN} \leq 0.2\text{ V}$	Automotive-A	All packages	–	–	10	$\mu\text{A}$
$t_{CDR}$ <sup>[15]</sup>	Chip deselect to data retention time				0	–	–	–
$t_R$ <sup>[16]</sup>	Operation recovery time				45	–	–	ns

## Data Retention Waveform

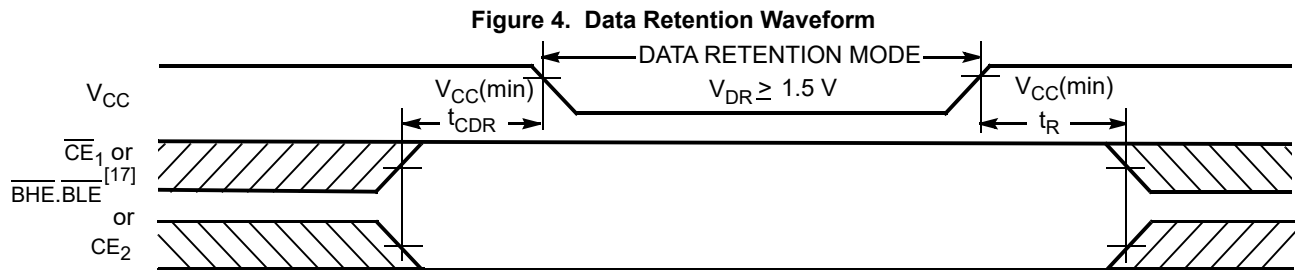

### Notes

13. Typical values are included for reference only and are not guaranteed or tested. Typical values are measured at  $V_{CC} = V_{CC(typ)}$ ,  $T_A = 25\text{ }^\circ\text{C}$ .
14. Chip enables ( $\overline{CE}_1$  and  $CE_2$ ), byte enables ( $\overline{BHE}$  and  $\overline{BLE}$ ) and  $\overline{BYTE}$  must be tied to CMOS levels to meet the  $I_{SB1} / I_{SB2} / I_{CCDR}$  spec. Other inputs can be left floating.
15. Tested initially and after any design or process changes that may affect these parameters.
16. Full device operation requires linear  $V_{CC}$  ramp from  $V_{DR}$  to  $V_{CC(min)} \geq 100\text{ }\mu\text{s}$  or stable at  $V_{CC(min)} \geq 100\text{ }\mu\text{s}$ .
17.  $\overline{BHE}$ . $\overline{BLE}$  is the AND of both  $\overline{BHE}$  and  $\overline{BLE}$ . Deselect the chip by either disabling the chip enable signals or by disabling both  $\overline{BHE}$  and  $\overline{BLE}$ .

## Switching Characteristics

Parameter <sup>[18, 19]</sup>	Description	45 ns (Automotive-A)		Unit
		Min	Max	
<b>Read Cycle</b>				
$t_{RC}$	Read cycle time	45	–	ns
$t_{AA}$	Address to data valid	–	45	ns
$t_{OHA}$	Data hold from address change	10	–	ns
$t_{ACE}$	$\overline{CE}_1$ LOW and $CE_2$ HIGH to data valid	–	45	ns
$t_{DOE}$	$\overline{OE}$ LOW to data valid	–	22	ns
$t_{LZOE}$	$\overline{OE}$ LOW to Low Z <sup>[20]</sup>	5	–	ns
$t_{HZOE}$	$\overline{OE}$ HIGH to High Z <sup>[20, 21]</sup>	–	18	ns
$t_{LZCE}$	$\overline{CE}_1$ LOW and $CE_2$ HIGH to Low Z <sup>[20]</sup>	10	–	ns
$t_{HZCE}$	$\overline{CE}_1$ HIGH and $CE_2$ LOW to High Z <sup>[20, 21]</sup>	–	18	ns
$t_{PU}$	$\overline{CE}_1$ LOW and $CE_2$ HIGH to power-up	0	–	ns
$t_{PD}$	$\overline{CE}_1$ HIGH and $CE_2$ LOW to power-down	–	45	ns
$t_{DBE}$	BLE / BHE LOW to data valid	–	45	ns
$t_{LZBE}$	BLE / BHE LOW to Low Z <sup>[20]</sup>	10	–	ns
$t_{HZBE}$	BLE / BHE HIGH to High Z <sup>[20, 21]</sup>	–	18	ns
<b>Write Cycle <sup>[22, 23]</sup></b>				
$t_{WC}$	Write cycle time	45	–	ns
$t_{SCE}$	$\overline{CE}_1$ LOW and $CE_2$ HIGH to write end	35	–	ns
$t_{AW}$	Address setup to write end	35	–	ns
$t_{HA}$	Address hold from write end	0	–	ns
$t_{SA}$	Address setup to write start	0	–	ns
$t_{PWE}$	$\overline{WE}$ pulse width	35	–	ns
$t_{BW}$	BLE / BHE LOW to write end	35	–	ns
$t_{SD}$	Data setup to write end	25	–	ns
$t_{HD}$	Data hold from write end	0	–	ns
$t_{HZWE}$	$\overline{WE}$ LOW to High Z <sup>[20, 21]</sup>	–	18	ns
$t_{LZWE}$	$\overline{WE}$ HIGH to Low Z <sup>[20]</sup>	10	–	ns

### Notes

18. Test conditions for all parameters other than tristate parameters assume signal transition time of 1 V/ns, timing reference levels of  $V_{CC(typ)}/2$ , input pulse levels of 0 to  $V_{CC(typ)}$ , and output loading of the specified  $I_{OL}/I_{OH}$  as shown in Figure 3 on page 5.
19. In an earlier revision of this device, under a specific application condition, READ and WRITE operations were limited to switching of the byte enable and/or chip enable signals as described in the application notes AN13842 and AN66311. However, the issue has been fixed and is in production now, and hence, these application notes are no longer applicable. They are available for download on our website as they contain information on the date code of the parts, beyond which the fix has been in production.
20. At any temperature and voltage condition,  $t_{HZCE}$  is less than  $t_{LZCE}$ ,  $t_{HZBE}$  is less than  $t_{LZBE}$ ,  $t_{HZOE}$  is less than  $t_{LZOE}$ , and  $t_{HZWE}$  is less than  $t_{LZWE}$  for any device.
21.  $t_{HZOE}$ ,  $t_{HZCE}$ ,  $t_{HZBE}$ , and  $t_{HZWE}$  transitions are measured when the outputs enter a high-impedance state.
22. The internal write time of the memory is defined by the overlap of  $\overline{WE}$ ,  $\overline{CE}_1 = V_{IL}$ , BHE or BLE or both =  $V_{IL}$ , and  $CE_2 = V_{IH}$ . All signals must be ACTIVE to initiate a write and any of these signals can terminate a write by going INACTIVE. The data input setup and hold timing must refer to the edge of the signal that terminates the write.
23. The minimum pulse width for Write Cycle No. 3 ( $\overline{WE}$  Controlled,  $\overline{OE}$  LOW) should be equal to the sum of  $t_{SD}$  and  $t_{HZWE}$ .

### Switching Waveforms

Figure 5. Read Cycle No. 1 (Address Transition Controlled) [24, 25]

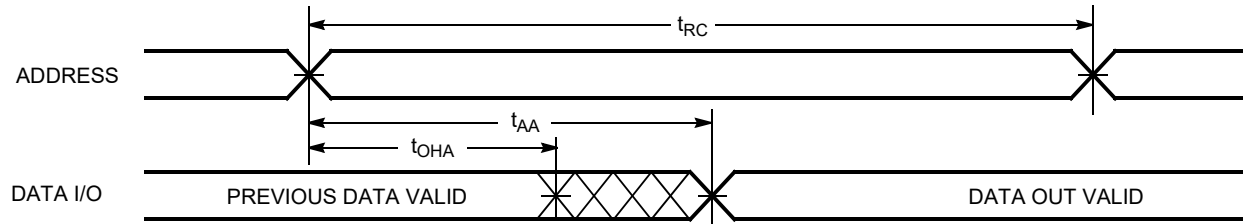
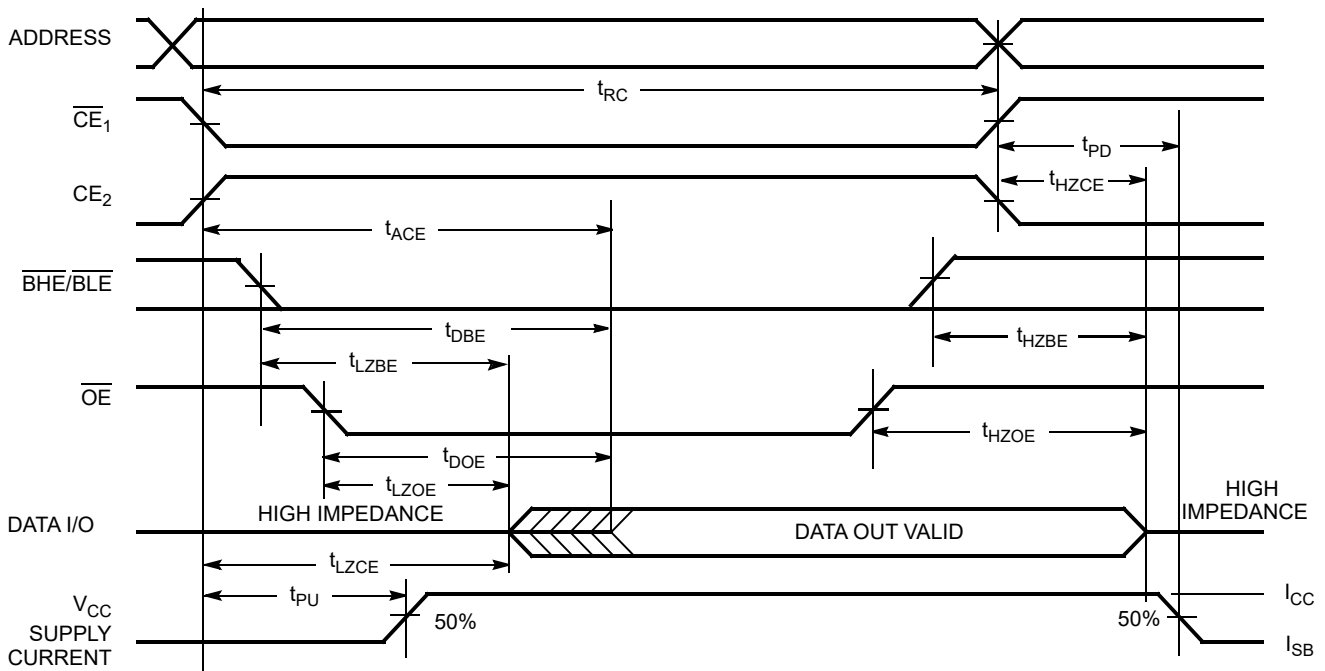

Figure 6. Read Cycle No. 2 ( $\overline{OE}$  Controlled) [25, 26]



**Notes**

- 24. The device is continuously selected.  $\overline{OE}$ ,  $\overline{CE}_1 = V_{IL}$ ,  $\overline{BHE}$ ,  $\overline{BLE}$  or both =  $V_{IL}$ , and  $CE_2 = V_{IH}$ .
- 25.  $\overline{WE}$  is HIGH for read cycle.
- 26. Address valid before or similar to  $\overline{CE}_1$ ,  $\overline{BHE}$ ,  $\overline{BLE}$  transition LOW and  $CE_2$  transition HIGH.

Switching Waveforms (continued)

Figure 7. Write Cycle No. 1 ( $\overline{WE}$  Controlled) [27, 28, 29]

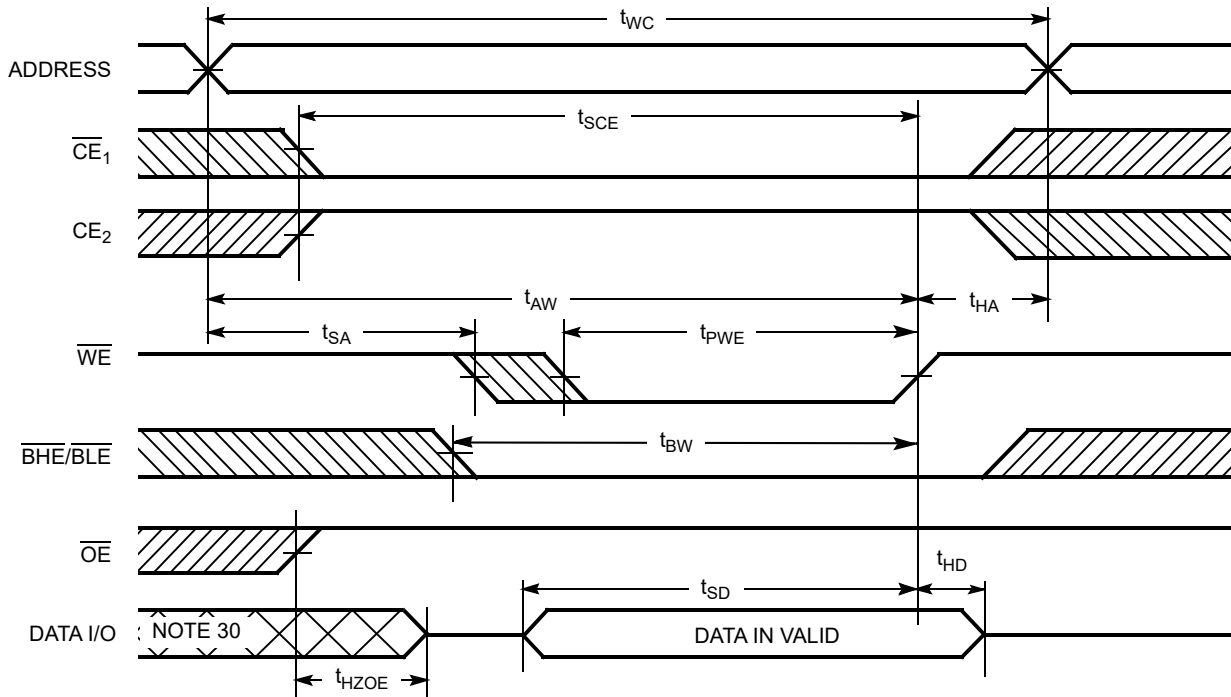

Notes

- 27. The internal write time of the memory is defined by the overlap of  $\overline{WE}$ ,  $\overline{CE}_1 = V_{IL}$ ,  $\overline{BHE}$  or  $\overline{BLE}$  or both =  $V_{IL}$ , and  $CE_2 = V_{IH}$ . All signals must be ACTIVE to initiate a write and any of these signals can terminate a write by going INACTIVE. The data input setup and hold timing must refer to the edge of the signal that terminates the write.
- 28. Data I/O is high impedance if  $\overline{OE} = V_{IH}$ .
- 29. If  $\overline{CE}_1$  goes HIGH and  $CE_2$  goes LOW simultaneously with  $\overline{WE} = V_{IH}$ , the output remains in a high-impedance state.
- 30. During this period the I/Os are in output state. Do not apply input signals.

Switching Waveforms (continued)

Figure 8. Write Cycle No. 2 ( $\overline{CE}_1$  or  $CE_2$  Controlled) [31, 32]

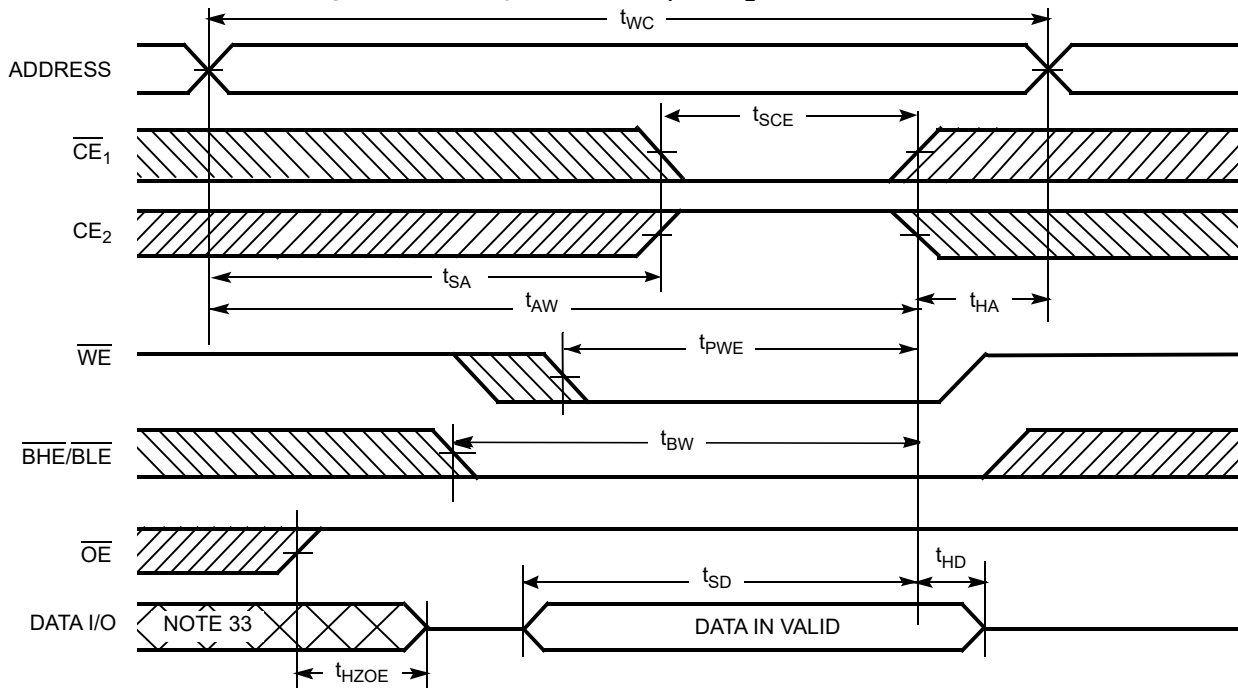

Notes

31. The internal write time of the memory is defined by the overlap of  $\overline{WE}$ ,  $\overline{CE}_1 = V_{IL}$ ,  $\overline{BHE}$  or  $\overline{BLE}$  or both =  $V_{IL}$ , and  $CE_2 = V_{IH}$ . All signals must be ACTIVE to initiate a write and any of these signals can terminate a write by going INACTIVE. The data input setup and hold timing must refer to the edge of the signal that terminates the write.
32. If  $\overline{CE}_1$  goes HIGH and  $CE_2$  goes LOW simultaneously with  $\overline{WE} = V_{IH}$ , the output remains in a high-impedance state.
33. During this period the I/Os are in output state. Do not apply input signals.

Switching Waveforms (continued)

Figure 9. Write Cycle No. 3 ( $\overline{WE}$  controlled,  $\overline{OE}$  LOW)<sup>[34]</sup>

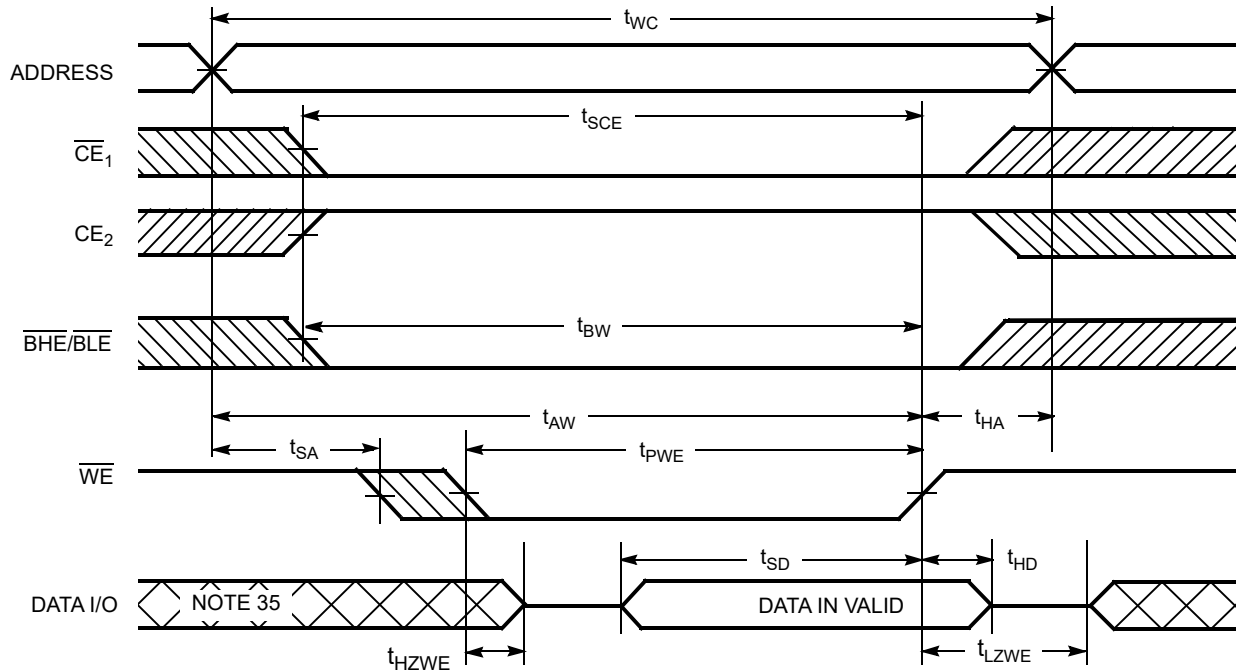
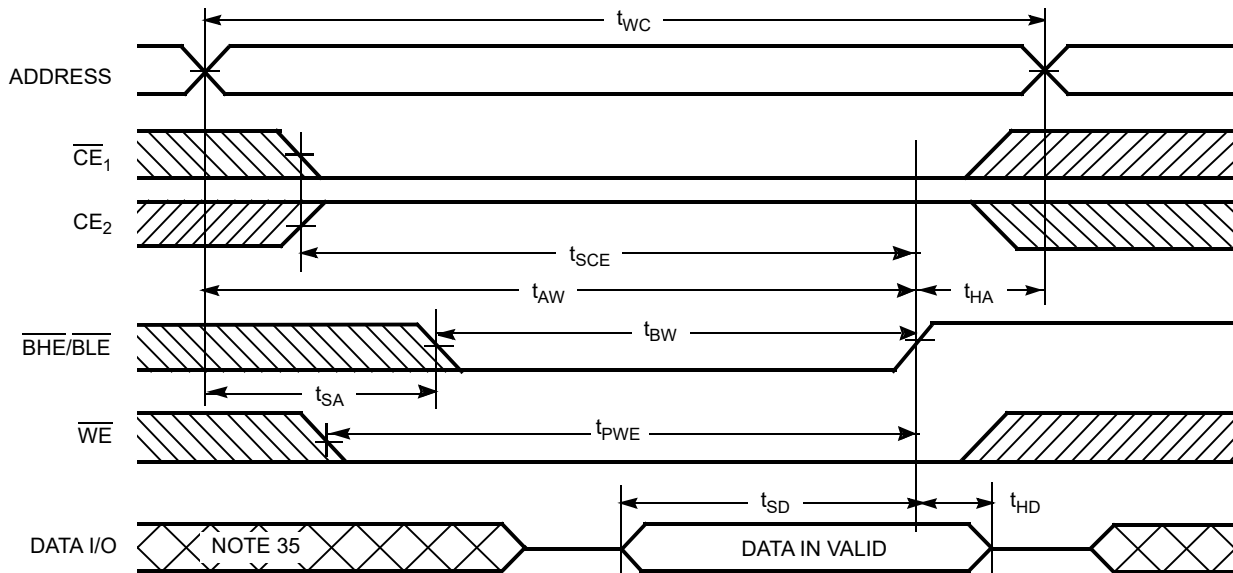

Figure 10. Write Cycle No. 4 ( $\overline{BHE}/\overline{BLE}$  controlled,  $\overline{OE}$  LOW)<sup>[34]</sup>



Notes

- 34. If  $\overline{CE}_1$  goes HIGH and  $CE_2$  goes LOW simultaneously with  $\overline{WE} = V_{IH}$ , the output remains in a high-impedance state.
- 35. During this period the I/Os are in output state. Do not apply input signals.

**Truth Table**

$\overline{CE}_1$	$\overline{CE}_2$	$\overline{WE}$	$\overline{OE}$	$\overline{BHE}$	$\overline{BLE}$	Inputs/Outputs	Mode	Power
H	X <sup>[36]</sup>	X	X	X <sup>[36]</sup>	X <sup>[36]</sup>	High Z	Deselect/Power-down	Standby (I <sub>SB</sub> )
X <sup>[36]</sup>	L	X	X	X <sup>[36]</sup>	X <sup>[36]</sup>	High Z	Deselect/Power-down	Standby (I <sub>SB</sub> )
X <sup>[36]</sup>	X <sup>[36]</sup>	X	X	H	H	High Z	Deselect/Power-down	Standby (I <sub>SB</sub> )
L	H	H	L	L	L	Data Out (I/O <sub>0</sub> –I/O <sub>15</sub> )	Read	Active (I <sub>CC</sub> )
L	H	H	L	H	L	Data Out (I/O <sub>0</sub> –I/O <sub>7</sub> ); High Z (I/O <sub>8</sub> –I/O <sub>15</sub> )	Read	Active (I <sub>CC</sub> )
L	H	H	L	L	H	High Z (I/O <sub>0</sub> –I/O <sub>7</sub> ); Data Out (I/O <sub>8</sub> –I/O <sub>15</sub> )	Read	Active (I <sub>CC</sub> )
L	H	H	H	L	H	High Z	Output disabled	Active (I <sub>CC</sub> )
L	H	H	H	H	L	High Z	Output disabled	Active (I <sub>CC</sub> )
L	H	H	H	L	L	High Z	Output disabled	Active (I <sub>CC</sub> )
L	H	L	X	L	L	Data In (I/O <sub>0</sub> –I/O <sub>15</sub> )	Write	Active (I <sub>CC</sub> )
L	H	L	X	H	L	Data In (I/O <sub>0</sub> –I/O <sub>7</sub> ); High Z (I/O <sub>8</sub> –I/O <sub>15</sub> )	Write	Active (I <sub>CC</sub> )
L	H	L	X	L	H	High Z (I/O <sub>0</sub> –I/O <sub>7</sub> ); Data In (I/O <sub>8</sub> –I/O <sub>15</sub> )	Write	Active (I <sub>CC</sub> )

**Note**

36. The 'X' (Don't care) state for the chip enables and Byte enables in the truth table refer to the logic state (either HIGH or LOW). Intermediate voltage levels on these pins is not permitted.

**Ordering Information**

Speed (ns)	Ordering Code	Package Diagram	Package Type	Operating Range
45	CY62167EV30LL-45BVXA	51-85150	48-ball VFBGA (6 × 8 × 1 mm) (Pb-free), Package Code: BZ48	Automotive-A
	CY62167EV30LL-45ZXAX	51-85183	48-pin TSOP I (Pb-free)	

**Ordering Code Definitions**

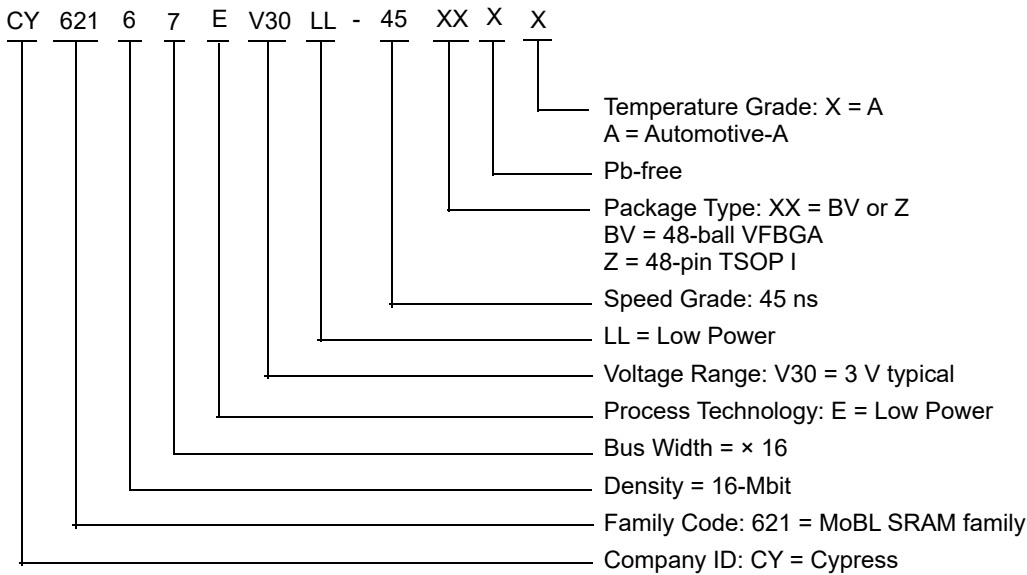

Package Diagrams

Figure 11. 48-ball VFBGA (6 × 8 × 1.0 mm) Package Outline, 51-85150

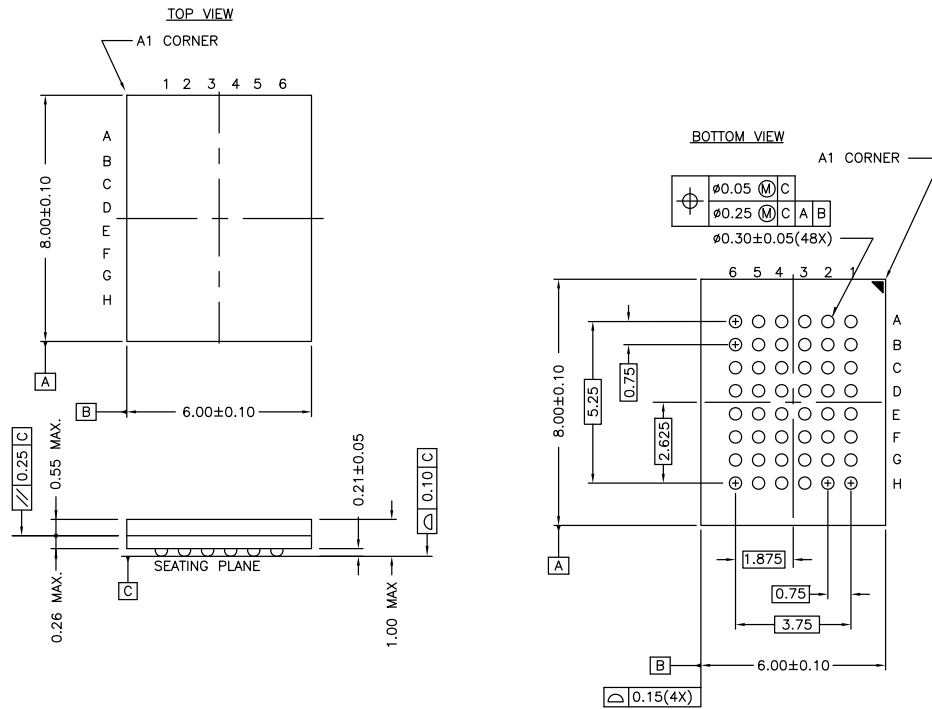

NOTE:  
 PACKAGE WEIGHT: See Cypress Package Material Declaration Datasheet (PMDD) posted on the Cypress web.

51-85150 \*H

Package Diagrams (continued)

Figure 12. 48-pin TSOP I (18.4 × 12 × 1.2 mm) Package Outline, 51-85183

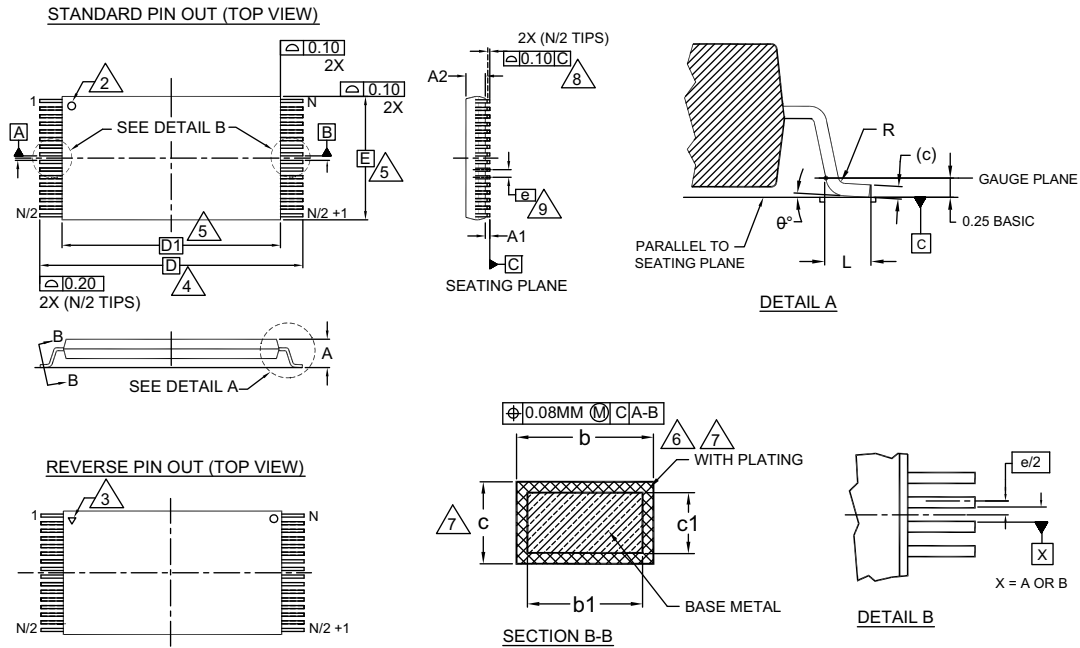

SYMBOL	DIMENSIONS		
	MIN.	NOM.	MAX.
A	—	—	1.20
A1	0.05	—	0.15
A2	0.95	1.00	1.05
b1	0.17	0.20	0.23
b	0.17	0.22	0.27
c1	0.10	—	0.16
c	0.10	—	0.21
D	20.00 BASIC		
D1	18.40 BASIC		
E	12.00 BASIC		
e	0.50 BASIC		
L	0.50	0.60	0.70
θ	0°	—	8
R	0.08	—	0.20
N	48		

NOTES:

1. DIMENSIONS ARE IN MILLIMETERS (mm).
2. PIN 1 IDENTIFIER FOR STANDARD PIN OUT (DIE UP).
3. PIN 1 IDENTIFIER FOR REVERSE PIN OUT (DIE DOWN): INK OR LASER MARK.
4. TO BE DETERMINED AT THE SEATING PLANE [-C-]. THE SEATING PLANE IS DEFINED AS THE PLANE OF CONTACT THAT IS MADE WHEN THE PACKAGE LEADS ARE ALLOWED TO REST FREELY ON A FLAT HORIZONTAL SURFACE.
5. DIMENSIONS D1 AND E DO NOT INCLUDE MOLD PROTRUSION. ALLOWABLE MOLD PROTRUSION ON E IS 0.15mm PER SIDE AND ON D1 IS 0.25mm PER SIDE.
6. DIMENSION b DOES NOT INCLUDE DAMBAR PROTRUSION. ALLOWABLE DAMBAR PROTRUSION SHALL BE 0.08mm TOTAL IN EXCESS OF b DIMENSION AT MAX. MATERIAL CONDITION. DAMBAR CANNOT BE LOCATED ON LOWER RADIUS OR THE FOOT. MINIMUM SPACE BETWEEN PROTRUSION AND AN ADJACENT LEAD TO BE 0.07mm.
7. THESE DIMENSIONS APPLY TO THE FLAT SECTION OF THE LEAD BETWEEN 0.10mm AND 0.25mm FROM THE LEAD TIP.
8. LEAD COPLANARITY SHALL BE WITHIN 0.10mm AS MEASURED FROM THE SEATING PLANE.
9. DIMENSION "e" IS MEASURED AT THE CENTERLINE OF THE LEADS.
10. JEDEC SPECIFICATION NO. REF: MO-142(D)DD.

51-85183 \*F

### Acronyms

Acronym	Description
$\overline{\text{BHE}}$	byte high enable
$\overline{\text{BLE}}$	byte low enable
$\overline{\text{CE}}$	chip enable
CMOS	complementary metal oxide semiconductor
I/O	input/output
$\overline{\text{OE}}$	output enable
SRAM	static random access memory
TSOP	thin small outline package
VFBGA	very fine-pitch ball grid array
$\overline{\text{WE}}$	write enable

### Document Conventions

#### Units of Measure

Symbol	Unit of Measure
°C	degree Celsius
MHz	megahertz
μA	microampere
μs	microsecond
mA	milliampere
mm	millimeter
ns	nanosecond
Ω	ohm
%	percent
pF	picofarad
V	volt
W	watt

**Document History Page**

Document Title: CY62167EV30 Automotive MoBL <sup>®</sup> , 16-Mbit (1M × 16/2M × 8) Static RAM Document Number: 38-05446				
Rev.	ECN No.	Orig. of Change	Submission Date	Description of Change
**	202600	AJU	01/23/2004	New data sheet.
*A	463674	NXR	See ECN	<p>Changed status from Advance Information to Preliminary            Removed 'L' bin and 35 ns speed bin from product offering            Modified Data sheet to include x8 configurability.            Changed ball E3 in FBGA pinout from DNU to NC            Changed the I<sub>SB2(Typ)</sub> value from 1.3 μA to 1.5 μA            Changed the I<sub>CC(Max)</sub> value from 40 mA to 25 mA            Changed Vcc stabilization time in footnote #9 from 100 μs to 200 μs            Changed the AC Test Load Capacitance value from 50 pF to 30 pF            Corrected typo in Data Retention Characteristics (t<sub>R</sub>) from 100 μs to t<sub>RC</sub> ns            Changed t<sub>OHA</sub>, t<sub>LZCE</sub>, t<sub>LZBE</sub>, and t<sub>LZWE</sub> from 6 ns to 10 ns            Changed t<sub>LZOE</sub> from 3 ns to 5 ns.            Changed t<sub>HZOE</sub>, t<sub>HZCE</sub>, t<sub>HZBE</sub>, and t<sub>HZWE</sub> from 15 ns to 18 ns            Changed t<sub>SCE</sub>, t<sub>AW</sub>, and t<sub>BW</sub> from 40 ns to 35 ns            Changed t<sub>PE</sub> from 30 ns to 35 ns            Changed t<sub>SD</sub> from 20 ns to 25 ns            Updated 48-ball FBGA Package Information.            Updated the Ordering Information table</p>
*B	469169	NSI	See ECN	Minor Change: Moved to external web
*C	1130323	VKN	See ECN	<p>Changed status from Preliminary to Final.            Changed I<sub>CC</sub> max spec from 2.8 mA to 4.0 mA for f = 1MHz            Changed I<sub>CC</sub> typ spec from 22 mA to 25 mA for f = f<sub>max</sub>            Changed I<sub>CC</sub> max spec from 25 mA to 30 mA for f = f<sub>max</sub>            Added V<sub>IL</sub> spec for TSOP I package and footnote# 9            Added footnote# 10 related to I<sub>SB2</sub> and I<sub>CCDR</sub>            Changed I<sub>SB1</sub> and I<sub>SB2</sub> spec from 8.5 μA to 12 μA            Changed I<sub>CCDR</sub> spec from 8 μA to 10 μA            Added footnote# 15 related to AC timing parameters</p>
*D	1323984	VKN / AESA	See ECN	<p>Modified I<sub>CCDR</sub> spec for TSOP I package            Added 48-ball VFBGA (6 × 7 × 1mm) package            Added footnote# 1 related to VFBGA (6 × 7 × 1mm) package            Updated Ordering Information table</p>
*E	2678799	VKN / PYRS	03/25/2009	Added Automotive-A information
*F	2720234	VKN / AESA	06/17/2009	Included -45BVXA part in the Ordering information table
*G	2880574	VKN	02/18/2010	<p>Modified I<sub>CCDR</sub> spec from 8 μA to 10 μA for Auto-A grade.            Added <a href="#">Contents</a>.            Updated all package diagrams.            Updated links in <a href="#">Sales</a>, <a href="#">Solutions</a>, and <a href="#">Legal Information</a>.</p>
*H	2934396	VKN	06/03/10	<p>Added footnote #25 related to chip enable.            Updated template.</p>
*I	3006301	RAME	08/12/2010	<p>Included BHE and BLE in I<sub>SB1</sub>, I<sub>SB2</sub>, and I<sub>CCDR</sub> test conditions to reflect Byte power down feature.            Removed 48-ball VFBGA (6 × 7 × 1 mm) package related information.            Added Acronyms and Ordering code definition.            Format updates to match template.</p>

**Document History Page** (continued)

Document Title: CY62167EV30 Automotive MoBL <sup>®</sup> , 16-Mbit (1M × 16/2M × 8) Static RAM Document Number: 38-05446				
Rev.	ECN No.	Orig. of Change	Submission Date	Description of Change
*J	3295175	RAME	06/29/2011	Updated <a href="#">Package Diagrams</a> . Added <a href="#">Document Conventions</a> . Removed reference to AN1064 SRAM system guidelines. Added I <sub>SB1</sub> to footnotes 10 and 14. Added byte enables to footnote 36 and referenced to Truth table.
*K	3411301	TAVA	10/17/2011	Updated <a href="#">Switching Waveforms</a> . Updated <a href="#">Package Diagrams</a> . Updated to new template.
*L	3667939	TAVA	07/09/2012	Updated <a href="#">Ordering Information</a> (No change in part numbers, updated details in Package Type column only). Updated <a href="#">Package Diagrams</a> (Spec 51-85150 (Updated figure caption only, no change in revision)).
*M	4102969	VINI	08/23/2013	Updated <a href="#">Switching Characteristics</a> : Updated Note 19. Updated <a href="#">Package Diagrams</a> : spec 51-85150 – Changed revision from *G to *H. Updated to new template. Completing Sunset Review.
*N	4574264	VINI	11/19/2014	Updated <a href="#">Functional Description</a> : Added “For a complete list of related documentation, <a href="#">click here</a> .” at the end. Updated <a href="#">Maximum Ratings</a> : Referred Notes 5 and 6 in “Supply voltage to ground potential”. Updated <a href="#">Switching Characteristics</a> : Added Note 23 and referred the same note in “Write Cycle”.
*O	4715413	VINI	04/07/2015	Updated <a href="#">Electrical Characteristics</a> : Updated details in “Test Conditions” column corresponding to I <sub>SB2</sub> parameter and added corresponding values. Added Note 11 and referred the same note in maximum values of I <sub>SB2</sub> parameter corresponding to Test Conditions “V <sub>CC</sub> = V <sub>CC(max)</sub> , Temperature = 25 °C” and “V <sub>CC</sub> = 3.0 V, Temperature = 40 °C”.
*P	5734005	VINI	05/11/2017	Updated <a href="#">Package Diagrams</a> : spec 51-85183 – Changed revision from *D to *F. Updated to new template.
*Q	6269846	NILE	08/02/2018	Removed references to industrial device from this datasheet. Refer to spec 002-24706 for details about Industrial option.

## Sales, Solutions, and Legal Information

### Worldwide Sales and Design Support

Cypress maintains a worldwide network of offices, solution centers, manufacturer's representatives, and distributors. To find the office closest to you, visit us at [Cypress Locations](#).

#### Products

Arm® Cortex® Microcontrollers	<a href="http://cypress.com/arm">cypress.com/arm</a>
Automotive	<a href="http://cypress.com/automotive">cypress.com/automotive</a>
Clocks & Buffers	<a href="http://cypress.com/clocks">cypress.com/clocks</a>
Interface	<a href="http://cypress.com/interface">cypress.com/interface</a>
Internet of Things	<a href="http://cypress.com/iot">cypress.com/iot</a>
Memory	<a href="http://cypress.com/memory">cypress.com/memory</a>
Microcontrollers	<a href="http://cypress.com/mcu">cypress.com/mcu</a>
PSoC	<a href="http://cypress.com/psoc">cypress.com/psoc</a>
Power Management ICs	<a href="http://cypress.com/pmic">cypress.com/pmic</a>
Touch Sensing	<a href="http://cypress.com/touch">cypress.com/touch</a>
USB Controllers	<a href="http://cypress.com/usb">cypress.com/usb</a>
Wireless Connectivity	<a href="http://cypress.com/wireless">cypress.com/wireless</a>

#### PSoC® Solutions

[PSoC 1](#) | [PSoC 3](#) | [PSoC 4](#) | [PSoC 5LP](#) | [PSoC 6 MCU](#)

#### Cypress Developer Community

[Community](#) | [Projects](#) | [Video](#) | [Blogs](#) | [Training](#) | [Components](#)

#### Technical Support

[cypress.com/support](http://cypress.com/support)



© Cypress Semiconductor Corporation, 2004–2018. This document is the property of Cypress Semiconductor Corporation and its subsidiaries, including Spansion LLC ("Cypress"). This document, including any software or firmware included or referenced in this document ("Software"), is owned by Cypress under the intellectual property laws and treaties of the United States and other countries worldwide. Cypress reserves all rights under such laws and treaties and does not, except as specifically stated in this paragraph, grant any license under its patents, copyrights, trademarks, or other intellectual property rights. If the Software is not accompanied by a license agreement and you do not otherwise have a written agreement with Cypress governing the use of the Software, then Cypress hereby grants you a personal, non-exclusive, nontransferable license (without the right to sublicense) (1) under its copyright rights in the Software (a) for Software provided in source code form, to modify and reproduce the Software solely for use with Cypress hardware products, only internally within your organization, and (b) to distribute the Software in binary code form externally to end users (either directly or indirectly through resellers and distributors), solely for use on Cypress hardware product units, and (2) under those claims of Cypress's patents that are infringed by the Software (as provided by Cypress, unmodified) to make, use, distribute, and import the Software solely for use with Cypress hardware products. Any other use, reproduction, modification, translation, or compilation of the Software is prohibited.

TO THE EXTENT PERMITTED BY APPLICABLE LAW, CYPRESS MAKES NO WARRANTY OF ANY KIND, EXPRESS OR IMPLIED, WITH REGARD TO THIS DOCUMENT OR ANY SOFTWARE OR ACCOMPANYING HARDWARE, INCLUDING, BUT NOT LIMITED TO, THE IMPLIED WARRANTIES OF MERCHANTABILITY AND FITNESS FOR A PARTICULAR PURPOSE. No computing device can be absolutely secure. Therefore, despite security measures implemented in Cypress hardware or software products, Cypress does not assume any liability arising out of any security breach, such as unauthorized access to or use of a Cypress product. In addition, the products described in these materials may contain design defects or errors known as errata which may cause the product to deviate from published specifications. To the extent permitted by applicable law, Cypress reserves the right to make changes to this document without further notice. Cypress does not assume any liability arising out of the application or use of any product or circuit described in this document. Any information provided in this document, including any sample design information or programming code, is provided only for reference purposes. It is the responsibility of the user of this document to properly design, program, and test the functionality and safety of any application made of this information and any resulting product. Cypress products are not designed, intended, or authorized for use as critical components in systems designed or intended for the operation of weapons, weapons systems, nuclear installations, life-support devices or systems, other medical devices or systems (including resuscitation equipment and surgical implants), pollution control or hazardous substances management, or other uses where the failure of the device or system could cause personal injury, death, or property damage ("Unintended Uses"). A critical component is any component of a device or system whose failure to perform can be reasonably expected to cause the failure of the device or system, or to affect its safety or effectiveness. Cypress is not liable, in whole or in part, and you shall and hereby do release Cypress from any claim, damage, or other liability arising from or related to all Unintended Uses of Cypress products. You shall indemnify and hold Cypress harmless from and against all claims, costs, damages, and other liabilities, including claims for personal injury or death, arising from or related to any Unintended Uses of Cypress products.

Cypress, the Cypress logo, Spansion, the Spansion logo, and combinations thereof, WICED, PSoC, CapSense, EZ-USB, F-RAM, and Traveo are trademarks or registered trademarks of Cypress in the United States and other countries. For a more complete list of Cypress trademarks, visit [cypress.com](http://cypress.com). Other names and brands may be claimed as property of their respective owners.

## Looking for pricing, stock, or lifecycle information?

Click below to explore more details on WIN SOURCE:

-  [View CY62167EV30LL-45BVXIT on WIN SOURCE](#)
-  [Infineon Technologies](#) Information

## Optimize Your Supply Chain with WIN SOURCE Solutions

-  Global Sourcing Solution
-  Obsolete Management
-  Cost Control Management
-  Shortage Management
-  Alternative Solution
-  Excess Inventory Management