



**THE DATASHEET OF
AS7C316096C-10BIN**





Rev. 1.0

AS7C316096C

2048K X 8 BIT HIGH SPEED CMOS SRAM

REVISION HISTORY

<u>Revision</u>	<u>Description</u>	<u>Issue Date</u>
Rev. 1.0	Initial Issue	June.2014

FEATURES

- Fast access time : 10ns
- **Low power consumption:**
 - Operating current:
90mA (TYP.)
 - Standby current:
4mA (TYP.)
- Single 3.3V power supply
- All inputs and outputs TTL compatible
- Fully static operation
- Tri-state output
- Data retention voltage: 1.5V (MIN.)
- **All parts ROHS Compliant**
- Package : 44-pin 400mil TSOP-II
48-ball 6mm x 8mm TFBGA

GENERAL DESCRIPTION

The AS7C316096C is a 16M-bit high speed CMOS static random access memory organized as 2048K words by 8 bits. It is fabricated using very high performance, high reliability CMOS technology. Its standby current is stable within the range of operating temperature.

The AS7C316096C operates from a single power supply of 3.3V and all inputs and outputs are fully TTL compatible

Table 1. Speed Grade Information

Product Family	V _{CC} Range	Speed	Power Dissipation	
			Standby(I _{SB1} , TYP.)	Operating(I _{CC} , TYP.)
AS7C316096C	2.7 ~ 3.6V	10ns	4mA	90mA

Table 2. Ordering Information

Product part No	Org	Temperature	Package
AS7C316096C-10TIN	2048K x 8	Industrial -40°C to 85°C	44-pin 400mil TSOP-II
AS7C316096C-10BIN	2048K x 8	Industrial -40°C to 85°C	48-ball 6mm x 8mm TFBGA

FUNCTIONAL BLOCK DIAGRAM

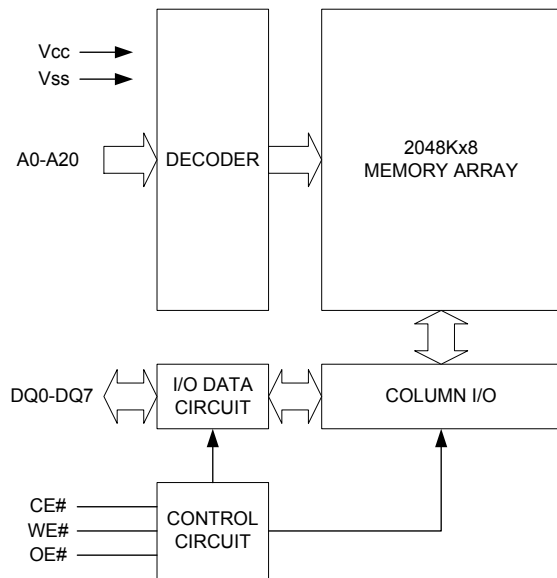

PIN DESCRIPTION

SYMBOL	DESCRIPTION
A0 - A20	Address Inputs
DQ0 - DQ7	Data Inputs/Outputs
CE#	Chip Enable Input
WE#	Write Enable Input
OE#	Output Enable Input
V _{CC}	Power Supply
V _{SS}	Ground

PIN CONFIGURATION

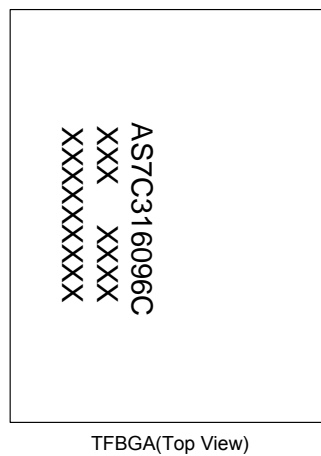
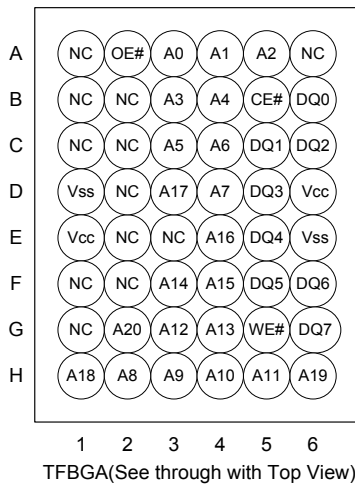
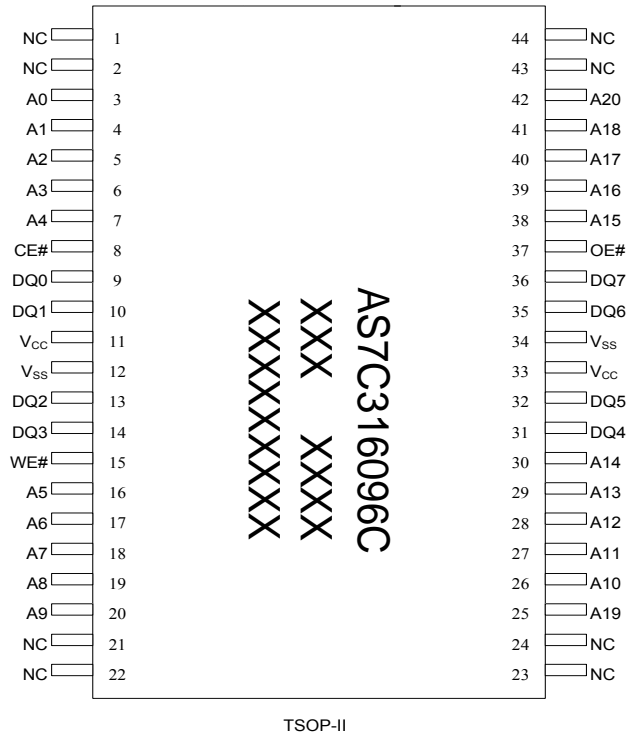

ABSOLUTE MAXIMUM RATINGS*

PARAMETER	SYMBOL	RATING	UNIT
Voltage on V_{CC} relative to V_{SS}	V_{T1}	-0.5 to 4.6	V
Voltage on any other pin relative to V_{SS}	V_{T2}	-0.5 to $V_{CC}+0.5$	V
Operating Temperature	T_A	-40 to 85(I grade)	°C
Storage Temperature	T_{STG}	-65 to 150	°C
Power Dissipation	P_D	1	W
DC Output Current	I_{OUT}	50	mA

*Stresses greater than those listed under "Absolute Maximum Ratings" may cause permanent damage to the device. This is a stress rating only and functional operation of the device or any other conditions above those indicated in the operational sections of this specification is not implied. Exposure to the absolute maximum rating conditions for extended period may affect device reliability.

TRUTH TABLE

MODE	CE#	OE#	WE#	I/O OPERATION	SUPPLY CURRENT
Standby	H	X	X	High-Z	I_{SB1}
Output Disable	L	H	H	High-Z	I_{CC}
Read	L	L	H	D_{OUT}	I_{CC}
Write	L	X	L	D_{IN}	I_{CC}

Note: H = V_{IH} , L = V_{IL} , X = Don't care.

DC ELECTRICAL CHARACTERISTICS

PARAMETER	SYMBOL	TEST CONDITION	MIN.	TYP. ⁴	MAX.	UNIT
Supply Voltage	V_{CC}		2.7	3.3	3.6	V
Input High Voltage	V_{IH}^{*1}		2.2	-	$V_{CC}+0.3$	V
Input Low Voltage	V_{IL}^{*2}		- 0.3	-	0.8	V
Input Leakage Current	I_{LI}	$V_{CC} \cong V_{IN} \cong V_{SS}$	- 1	-	1	μA
Output Leakage Current	I_{LO}	$V_{CC} \cong V_{OUT} \cong V_{SS}$, Output Disabled	- 1	-	1	μA
Output High Voltage	V_{OH}	$I_{OH} = -4mA$	2.4	-	-	V
Output Low Voltage	V_{OL}	$I_{OL} = 8mA$	-	-	0.4	V
Average Operating Power Supply Current	I_{CC}	CE# ≤ 0.2 , Others at 0.2V or $V_{CC}-0.2V$ $I_{IO} = 0mA, f = max$		90	120	mA
Standby Power Supply Current	I_{SB1}	CE# $\geq V_{CC} - 0.2V$, Others at 0.2V or $V_{CC} - 0.2V$	-	4	40	mA

Notes:

- $V_{IH}(max) = V_{CC} + 2.0V$ for pulse width less than 6ns.
- $V_{IL}(min) = V_{SS} - 2.0V$ for pulse width less than 6ns.
- Over/Undershoot specifications are characterized on engineering evaluation stage, not for mass production test.
- Typical values are included for reference only and are not guaranteed or tested.
Typical values are measured at $V_{CC} = V_{CC}(TYP.)$ and $T_A = 25^\circ C$

CAPACITANCE ($T_A = 25^\circ\text{C}$, $f = 1.0\text{MHz}$)

PARAMETER	SYMBOL	MIN.	MAX	UNIT
Input Capacitance	C_{IN}	-	8	pF
Input/Output Capacitance	$C_{I/O}$	-	10	pF

Note : These parameters are guaranteed by device characterization, but not production tested.

AC TEST CONDITIONS

Speed	10ns
Input Pulse Levels	0.2V to $V_{CC} - 0.2V$
Input Rise and Fall Times	3ns
Input and Output Timing Reference Levels	$V_{CC}/2$
Output Load	$C_L = 30\text{pF} + 1\text{TTL}$, $I_{OH}/I_{OL} = -4\text{mA}/8\text{mA}$

AC ELECTRICAL CHARACTERISTICS
(1) READ CYCLE

PARAMETER	SYM.	AS7C316096C-10		UNIT
		MIN.	MAX.	
Read Cycle Time	t_{RC}	10	-	ns
Address Access Time	t_{AA}	-	10	ns
Chip Enable Access Time	t_{ACE}	-	10	ns
Output Enable Access Time	t_{OE}	-	4.5	ns
Chip Enable to Output in Low-Z	t_{CLZ}^*	2	-	ns
Output Enable to Output in Low-Z	t_{OLZ}^*	0	-	ns
Chip Disable to Output in High-Z	t_{CHZ}^*	-	4	ns
Output Disable to Output in High-Z	t_{OHZ}^*	-	4	ns
Output Hold from Address Change	t_{OH}	2	-	ns

(2) WRITE CYCLE

PARAMETER	SYM.	AS7C316096C-10		UNIT
		MIN.	MAX.	
Write Cycle Time	t_{WC}	10	-	ns
Address Valid to End of Write	t_{AW}	8	-	ns
Chip Enable to End of Write	t_{CW}	8	-	ns
Address Set-up Time	t_{AS}	0	-	ns
Write Pulse Width	t_{WP}	8	-	ns
Write Recovery Time	t_{WR}	0	-	ns
Data to Write Time Overlap	t_{DW}	6	-	ns
Data Hold from End of Write Time	t_{DH}	0	-	ns
Output Active from End of Write	t_{OW}^*	2	-	ns
Write to Output in High-Z	t_{WHZ}^*	-	4	ns

*These parameters are guaranteed by device characterization, but not production tested.

TIMING WAVEFORMS

READ CYCLE 1 (Address Controlled) (1,2)

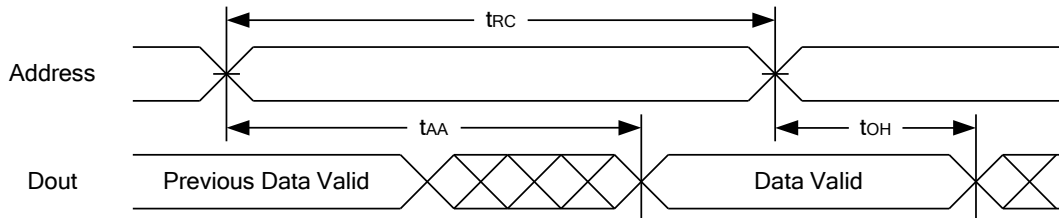

READ CYCLE 2 (CE# and OE# Controlled) (1,3,4,5)

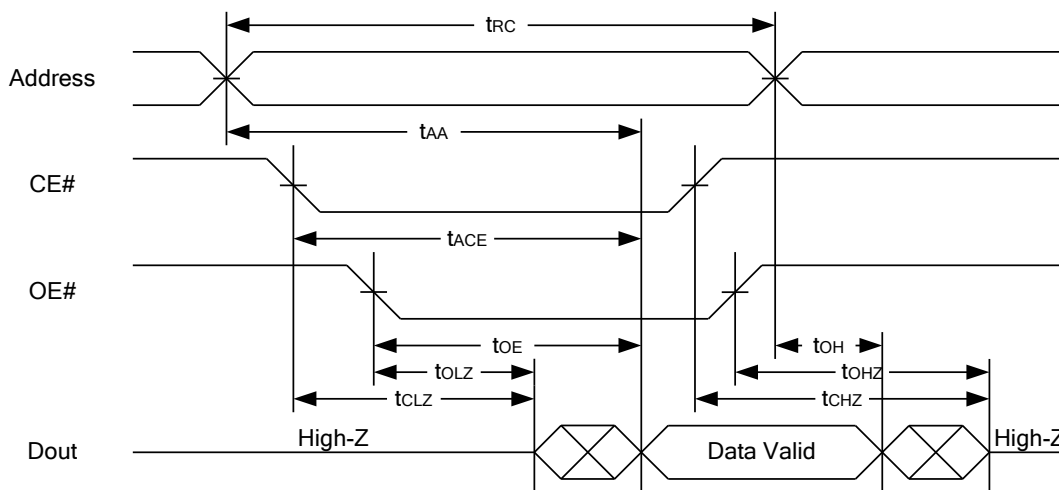

Notes :

1. WE# is high for read cycle.
2. Device is continuously selected OE# = low, CE# = low.
3. Address must be valid prior to or coincident with CE# = low,; otherwise tAA is the limiting parameter.
4. tCLZ, tOLZ, tCHZ and tOHZ are specified with CL = 5pF. Transition is measured ±500mV from steady state.
5. At any given temperature and voltage condition, tCHZ is less than tCLZ, tOHZ is less than tOLZ.

WRITE CYCLE 1 (WE# Controlled) (1,2,3,5,6)

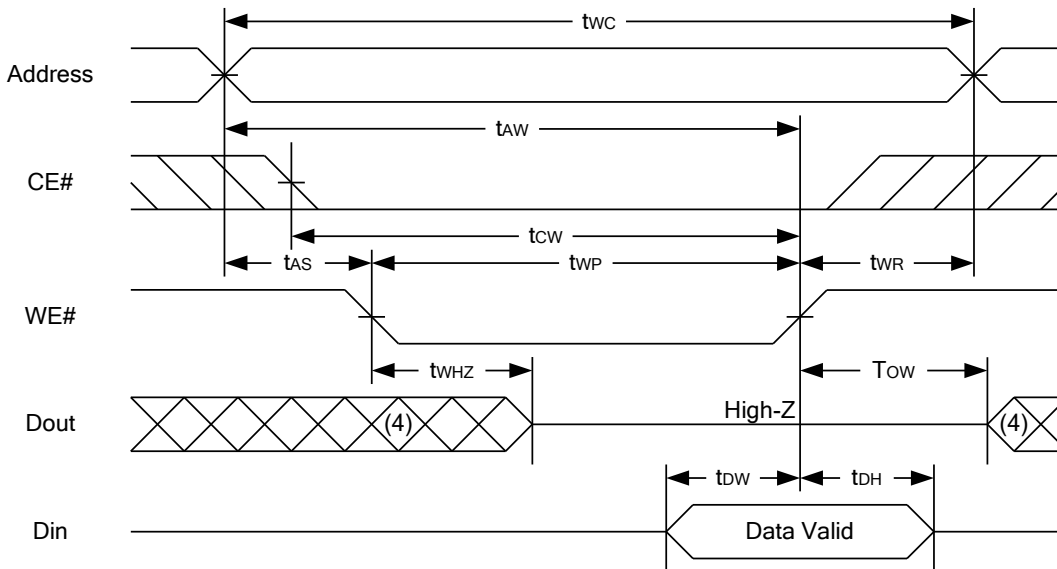

WRITE CYCLE 2 (CE# Controlled) (1,2,5,6)

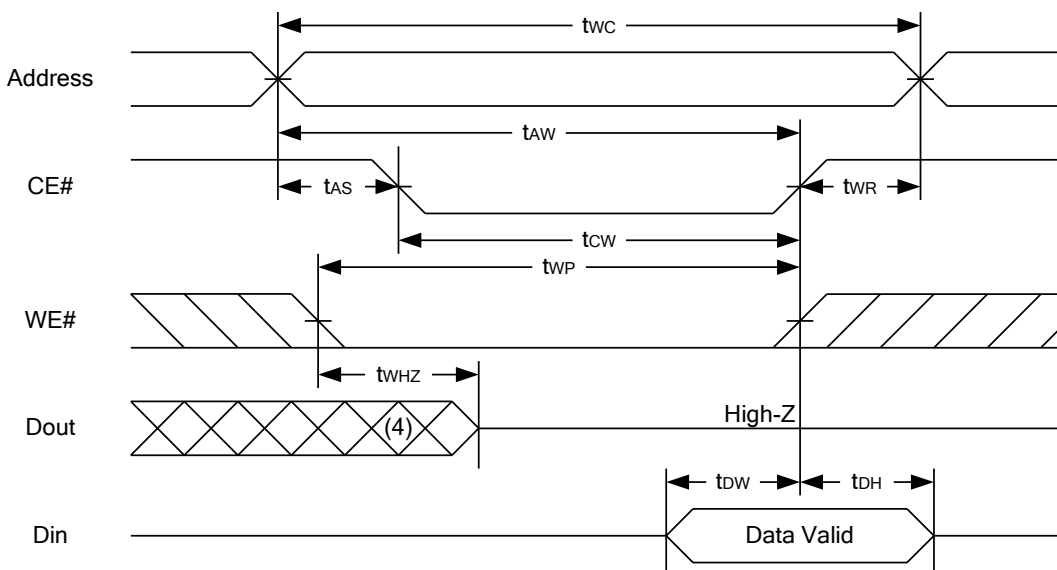

Notes :

1. WE#, CE#, LB#, UB# must be high during all address transitions.
2. A write occurs during the overlap of a low CE#, low WE#, LB# or UB# = low.
3. During a WE# controlled write cycle with OE# low, t_{WP} must be greater than $t_{WHZ} + t_{DW}$ to allow the drivers to turn off and data to be placed on the bus.
4. During this period, I/O pins are in the output state, and input signals must not be applied.
5. If the CE#, LB#, UB# low transition occurs simultaneously with or after WE# low transition, the outputs remain in a high impedance state.
6. t_{OW} and t_{WHZ} are specified with $C_L = 5\text{pF}$. Transition is measured $\pm 500\text{mV}$ from steady state.

DATA RETENTION CHARACTERISTICS

PARAMETER	SYMBOL	TEST CONDITION	MIN.	TYP.	MAX.	UNIT
V _{CC} for Data Retention	V _{DR}	CE# ≥ V _{CC} - 0.2V	1.5	-	3.6	V
Data Retention Current	I _{DR}	V _{CC} = 1.5V CE# ≥ V _{CC} - 0.2V Others at 0.2V or V _{CC} - 0.2V	-	4	40	mA
Chip Disable to Data Retention Time	t _{CDR}	See Data Retention Waveforms (below)	0	-	-	ns
Recovery Time	t _R		t _{RC} *	-	-	ns

t_{RC}* = Read Cycle Time

DATA RETENTION WAVEFORM

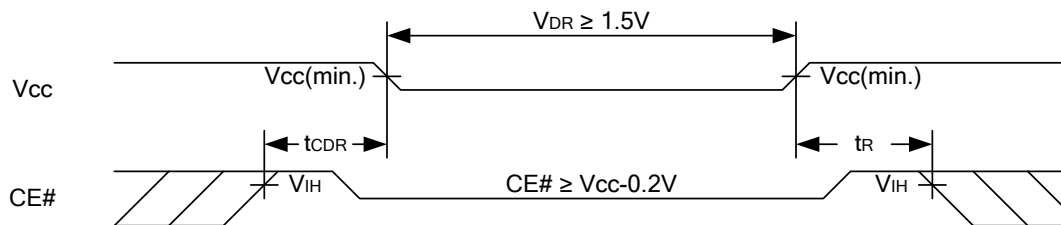

PACKAGE OUTLINE DIMENSION

44-pin 400mil TSOP-II Package Outline Dimension

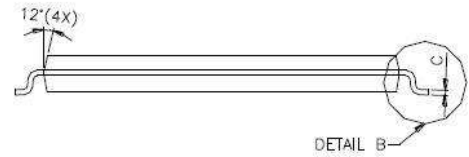
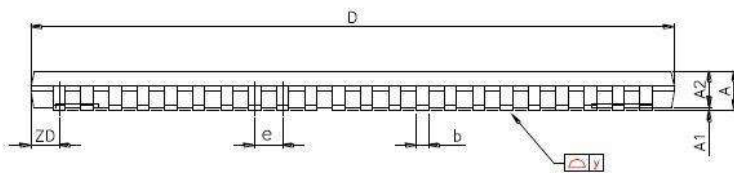
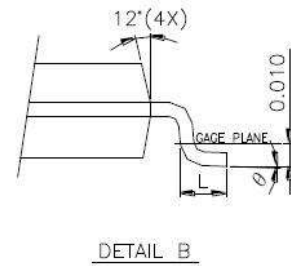
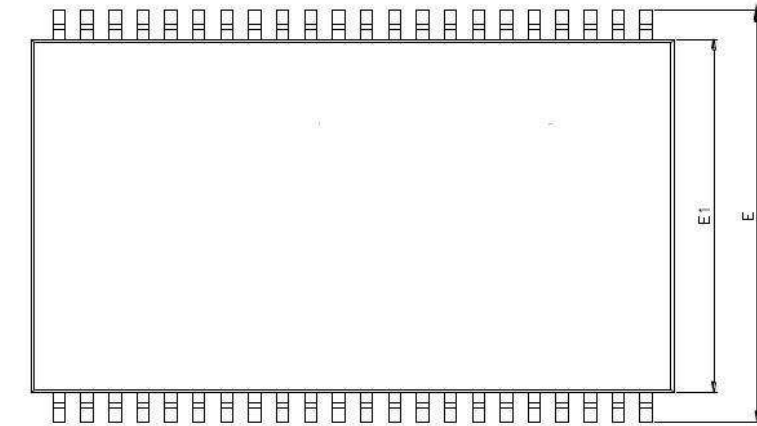

SYMBOLS	DIMENSIONS IN MILLIMETERS			DIMENSIONS IN MILS		
	MIN.	NOM.	MAX.	MIN.	NOM.	MAX.
A	-	-	1.20	-	-	47.2
A1	0.05	0.10	0.15	2.0	3.9	5.9
A2	0.95	1.00	1.05	37.4	39.4	41.3
b	0.30	-	0.45	11.8	-	17.7
c	0.12	-	0.21	4.7	-	8.3
D	18.212	18.415	18.618	717	725	733
E	11.506	11.760	12.014	453	463	473
E1	9.957	10.160	10.363	392	400	408
e	-	0.800	-	-	31.5	-
L	0.40	0.50	0.60	15.7	19.7	23.6
ZD	-	0.805	-	-	31.7	-
y	-	-	0.076	-	-	3
θ	0°	3°	6°	0°	3°	6°

48-ball 6mm x 8mm TFBGA Package Outline Dimension

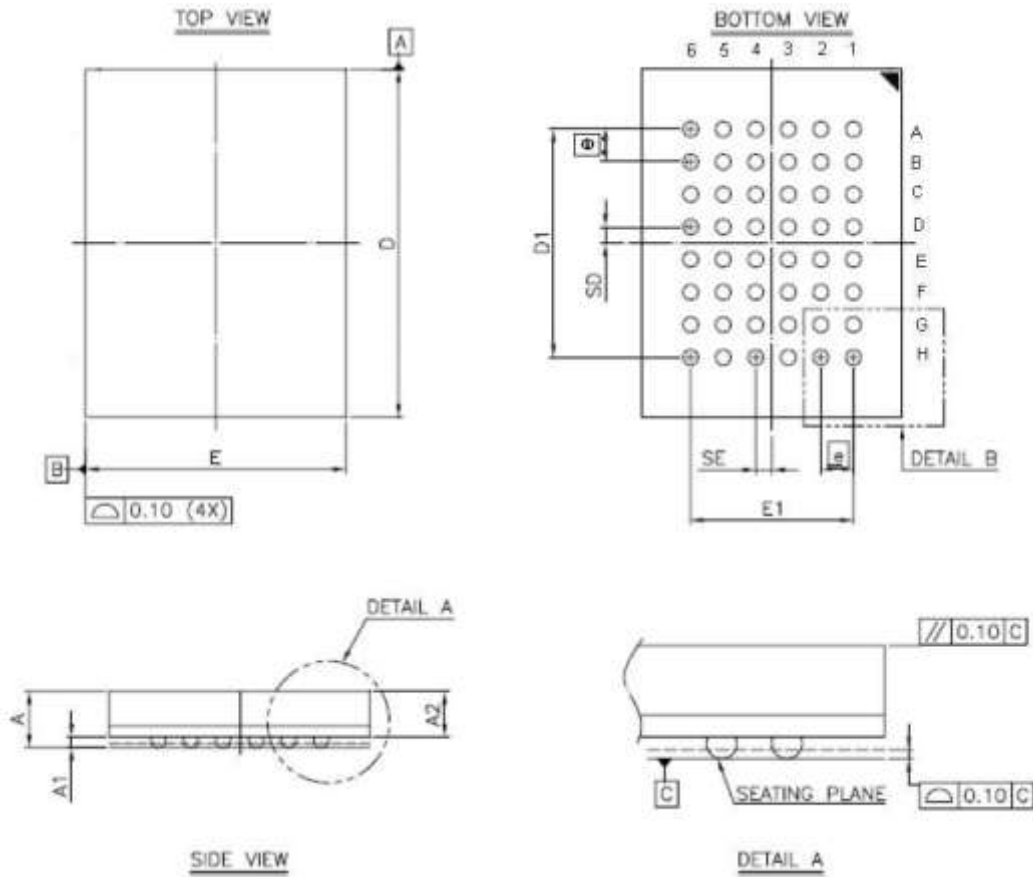

SYM.	DIMENSION (mm)			DIMENSION (inch)		
	MIN.	NOM.	MAX.	MIN.	NOM.	MAX.
A	—	—	1.40	—	—	0.055
A1	0.20	0.25	0.30	0.008	0.010	0.012
A2	—	—	1.05	—	—	0.041
b	0.30	0.35	0.40	0.012	0.014	0.016
D	7.95	8.00	8.05	0.313	0.315	0.317
D1	5.25 BSC			0.207 BSC		
E	5.95	6.00	6.05	0.234	0.236	0.238
E1	3.75 BSC			0.148 BSC		
SE	0.375 TYP			0.015 TYP		
SD	0.375 TYP			0.015 TYP		
Ⓢ	0.75 BSC			0.030 BSC		

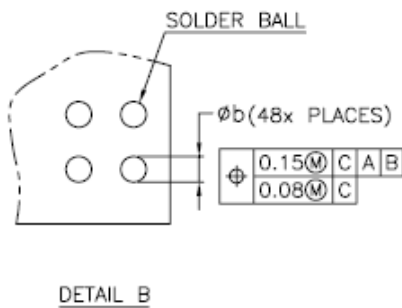
NOTE:

1. CONTROLLING DIMENSION : MILLIMETER.
2. REFERENCE DOCUMENT : JEDEC MO-207.



Rev. 1.0

AS7C316096C



2048K X 8 BIT HIGH SPEED CMOS SRAM

Alliance Memory Inc. reserves the rights to change the specifications and products without notice.

Alliance Memory, Inc., 551 Taylor Way, Suite #1, San Carlos, CA 94070, USA
Tel: +1 650 610 6800 Fax: +1 650 620 9211

Looking for pricing, stock, or lifecycle information?

Click below to explore more details on WIN SOURCE:

-  [View AS7C316096C-10BIN on WIN SOURCE](#)
-  [Alliance Memory, Inc. Information](#)

Optimize Your Supply Chain with WIN SOURCE Solutions

-  Global Sourcing Solution
-  Obsolete Management
-  Cost Control Management
-  Shortage Management
-  Alternative Solution
-  Excess Inventory Management