



**THE DATASHEET OF
CY7C1061AV33-10ZXIT**



16-Mbit (1M x 16) Static RAM

Features

- High speed
 - $t_{AA} = 10 \text{ ns}$
- Low active power
 - 990 mW (max)
- Operating voltages of $3.3 \pm 0.3\text{V}$
- 2.0V data retention
- Automatic power down when deselected
- TTL compatible inputs and outputs
- Easy memory expansion with \overline{CE}_1 and CE_2 features
- Available in Pb-free and non Pb-free 54-pin TSOP II package and non Pb-free 60-ball fine pitch ball grid array (FBGA) package

Functional Description

The CY7C1061AV33 is a high performance CMOS Static RAM organized as 1,048,576 words by 16 bits.

To write to the device, enable the chip (\overline{CE}_1 LOW and CE_2 HIGH) while forcing the Write Enable (\overline{WE}) input LOW. If Byte Low Enable (\overline{BLE}) is LOW, then data from IO pins (IO_0 through IO_7), is written into the location specified on the address pins (A_0 through A_{19}). If Byte High Enable (\overline{BHE}) is LOW, then data from IO pins (IO_8 through IO_{15}) is written into the location specified on the address pins (A_0 through A_{19}).

To read from the device, enable the chip by taking \overline{CE}_1 LOW and CE_2 HIGH while forcing the Output Enable (\overline{OE}) LOW and the Write Enable (\overline{WE}) HIGH. If Byte Low Enable (\overline{BLE}) is LOW, then data from the memory location specified by the address pins will appear on IO_0 to IO_7 . If Byte High Enable (\overline{BHE}) is LOW, then data from memory will appear on IO_8 to IO_{15} . See "Truth Table" on page 7 for a complete description of Read and Write modes.

The input/output pins (IO_0 through IO_{15}) are placed in a high-impedance state when the device is deselected (\overline{CE}_1 HIGH/ CE_2 LOW), the outputs are disabled (\overline{OE} HIGH), the \overline{BHE} and \overline{BLE} are disabled (\overline{BHE} , \overline{BLE} HIGH), or a Write operation is in progress (\overline{CE}_1 LOW, CE_2 HIGH, and \overline{WE} LOW).

Logic Block Diagram

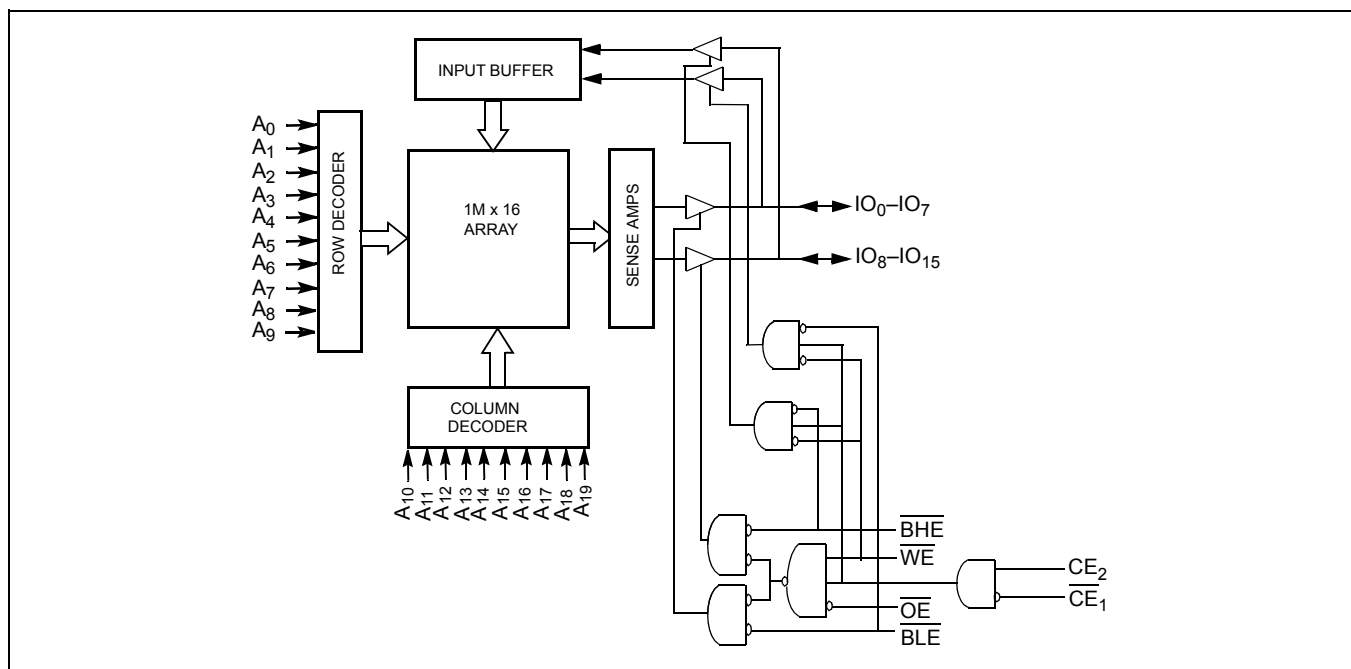

Selection Guide

		-10	-12	Unit
Maximum Access Time		10	12	ns
Maximum Operating Current	Commercial	275	260	mA
	Industrial	275	260	
Maximum CMOS Standby Current	Commercial/Industrial	50	50	mA

Pin Configurations ^[1, 2]

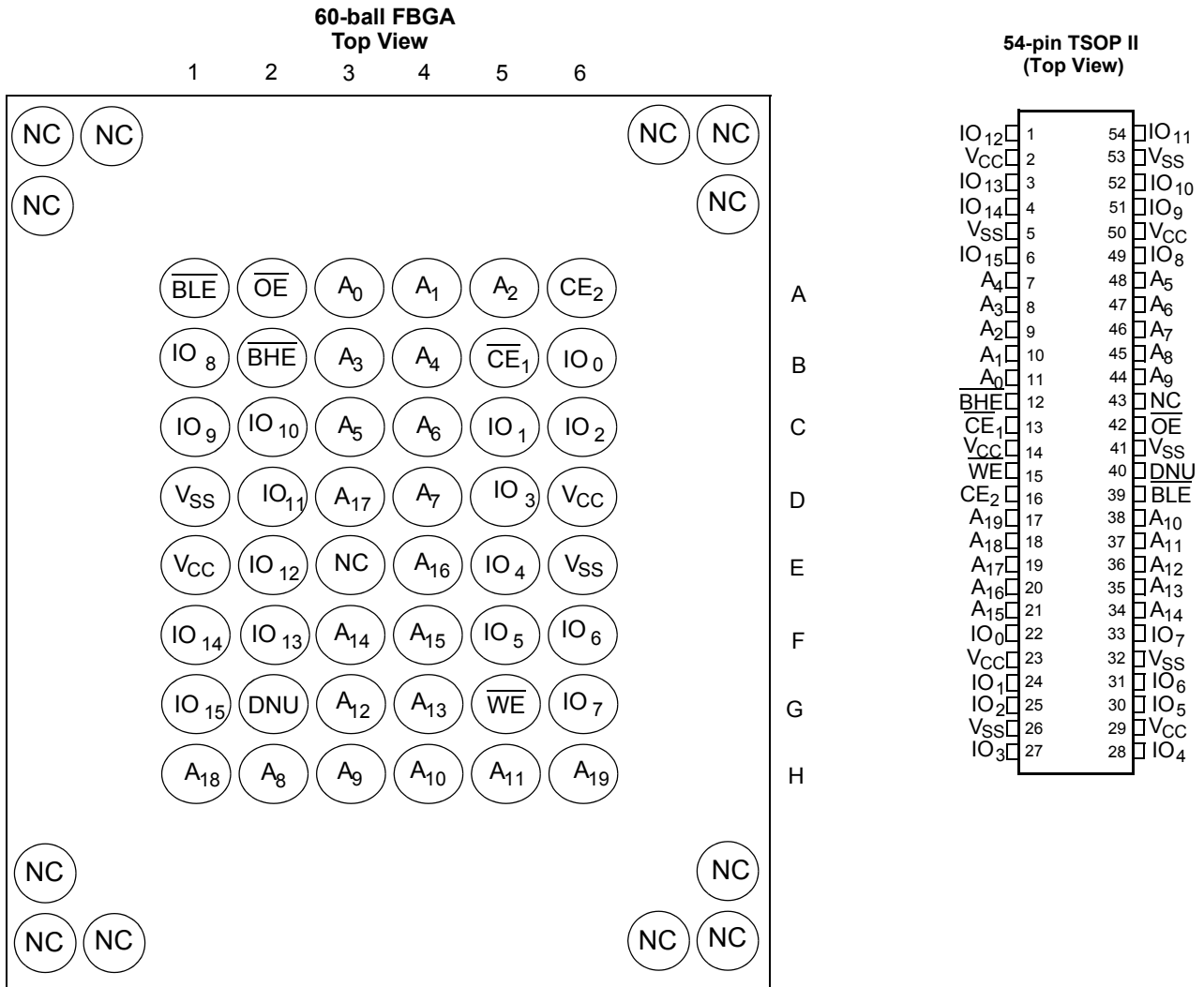

Notes

1. NC pins are not connected on the die.
2. DNU (Do Not Use) pins have to be left floating or tied to VSS to ensure proper operation.

Maximum Ratings

Exceeding maximum ratings may shorten the useful life of the device. These user guidelines are not tested.

- Storage Temperature -65°C to +150°C
- Ambient Temperature with Power Applied..... -55°C to +125°C
- Supply Voltage on V_{CC} to Relative GND [3] ... -0.5V to +4.6V
- DC Voltage Applied to Outputs in High-Z State [3] -0.5V to V_{CC} + 0.5V

- DC Input Voltage [3] -0.5V to V_{CC} + 0.5V
- Current into Outputs (LOW)..... 20 mA

Operating Range

Range	Ambient Temperature	V _{CC}
Commercial	0°C to +70°C	3.3V ± 0.3V
Industrial	-40°C to +85°C	

DC Electrical Characteristics (Over the Operating Range)

Parameter	Description	Test Conditions	-10		-12		Unit	
			Min	Max	Min	Max		
V _{OH}	Output HIGH Voltage	I _{OH} = -4.0 mA	2.4		2.4		V	
V _{OL}	Output LOW Voltage	I _{OL} = 8.0 mA		0.4		0.4	V	
V _{IH}	Input HIGH Voltage		2.0	V _{CC} + 0.3	2.0	V _{CC} + 0.3	V	
V _{IL}	Input LOW Voltage [3]		-0.3	0.8	-0.3	0.8	V	
I _{IX}	Input Leakage Current	GND ≤ V _I ≤ V _{CC}	-1	+1	-1	+1	µA	
I _{OZ}	Output Leakage Current	GND ≤ V _O ≤ V _{CC} , Output Disabled	-1	+1	-1	+1	µA	
I _{CC}	V _{CC} Operating Supply Current	V _{CC} = max, f = f _{max} = 1/t _{RC}	Commercial		275		260	mA
			Industrial		275		260	mA
I _{SB1}	Automatic CE Power-down Current —TTL Inputs	CE ₂ ≤ V _{IL} , max V _{CC} , CE ≥ V _{IH} , V _{IN} ≥ V _{IH} or V _{IN} ≤ V _{IL} , f = f _{max}		70		70	mA	
I _{SB2}	Automatic CE Power-down Current —CMOS Inputs	CE ₂ ≤ 0.3V max V _{CC} , CE ≥ V _{CC} - 0.3V, V _{IN} ≥ V _{CC} - 0.3V, or V _{IN} ≤ 0.3V, f = 0	Commercial/Industrial		50		50	mA

Capacitance [4]

Parameter	Description	Test Conditions	TSOP II	FBGA	Unit
C _{IN}	Input Capacitance	T _A = 25°C, f = 1 MHz, V _{CC} = 3.3V	6	8	pF
C _{OUT}	IO Capacitance		8	10	pF

AC Test Loads and Waveforms [5]

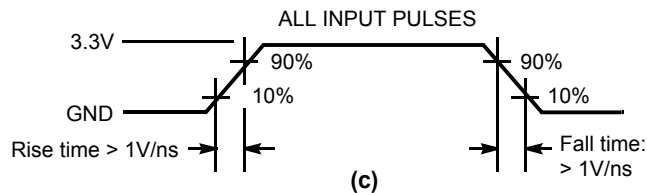
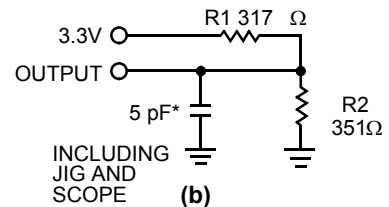
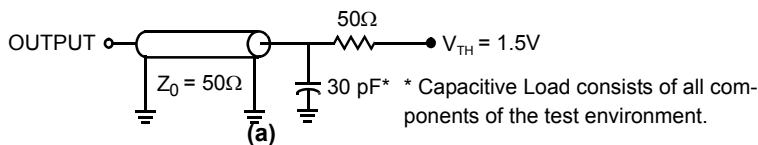

Notes

3. V_{IL} (min) = -2.0V for pulse durations of less than 20 ns.
4. Tested initially and after any design or process changes that may affect these parameters.
5. Valid SRAM operation does not occur until the power supplies have reached the minimum operating V_{DD} (3.0V). As soon as 1 ms (T_{power}) after reaching the minimum operating V_{DD}, normal SRAM operation can begin including reduction in V_{DD} to the data retention (V_{CCDR}, 2.0V) voltage.

AC Switching Characteristics (Over the Operating Range) ^[6]

Parameter	Description	-10		-12		Unit
		Min	Max	Min	Max	
Read Cycle						
t_{power}	V_{CC} (typical) to the first access ^[7]	1		1		ms
t_{RC}	Read Cycle Time	10		12		ns
t_{AA}	Address to Data Valid		10		12	ns
t_{OHA}	Data Hold from Address Change	3		3		ns
t_{ACE}	\overline{CE}_1 LOW/ CE_2 HIGH to Data Valid		10		12	ns
t_{DOE}	\overline{OE} LOW to Data Valid		5		6	ns
t_{LZOE}	\overline{OE} LOW to Low-Z	1		1		ns
t_{HZOE}	\overline{OE} HIGH to High-Z ^[8]		5		6	ns
t_{LZCE}	\overline{CE}_1 LOW/ CE_2 HIGH to Low-Z ^[8]	3		3		ns
t_{HZCE}	\overline{CE}_1 HIGH/ CE_2 LOW to High-Z ^[8]		5		6	ns
t_{PU}	\overline{CE}_1 LOW/ CE_2 HIGH to Power Up ^[9]	0		0		ns
t_{PD}	\overline{CE}_1 HIGH/ CE_2 LOW to Power Down ^[9]		10		12	ns
t_{DBE}	Byte Enable to Data Valid		5		6	ns
t_{LZBE}	Byte Enable to Low-Z	1		1		ns
t_{HZBE}	Byte Disable to High-Z		5		6	ns
Write Cycle ^[10, 11]						
t_{WC}	Write Cycle Time	10		12		ns
t_{SCE}	\overline{CE}_1 LOW/ CE_2 HIGH to Write End	7		8		ns
t_{AW}	Address Setup to Write End	7		8		ns
t_{HA}	Address Hold from Write End	0		0		ns
t_{SA}	Address Setup to Write Start	0		0		ns
t_{PWE}	\overline{WE} Pulse Width	7		8		ns
t_{SD}	Data Setup to Write End	5.5		6		ns
t_{HD}	Data Hold from Write End	0		0		ns
t_{LZWE}	\overline{WE} HIGH to Low-Z ^[8]	3		3		ns
t_{HZWE}	\overline{WE} LOW to High-Z ^[8]		5		6	ns
t_{BW}	Byte Enable to End of Write	7		8		ns

Notes

- Test conditions assume signal transition time of 3 ns or less, timing reference levels of 1.5V, input pulse levels of 0 to 3.0V, and output loading of the specified I_{OL}/I_{OH} and specified transmission line loads. Test conditions for the Read cycle use output loading shown in (a) of the "AC Test Loads and Waveforms ^[5]" on page 3, unless specified otherwise.
- This part has a voltage regulator that steps down the voltage from 3V to 2V internally. t_{power} time must be provided initially before a Read/Write operation is started.
- t_{HZOE} , t_{HZCE} , t_{HZWE} , t_{HZBE} and t_{LZOE} , t_{LZCE} , t_{LZWE} , t_{LZBE} are specified with a load capacitance of 5 pF as in (b) of "AC Test Loads and Waveforms ^[5]" on page 3. Transition is measured ± 200 mV from steady-state voltage.
- These parameters are guaranteed by design and are not tested.
- The internal Write time of the memory is defined by the overlap of \overline{CE}_1 LOW (CE_2 HIGH) and \overline{WE} LOW. Chip enables must be active and \overline{WE} and byte enables must be LOW to initiate a Write, and the transition of any of these signals can terminate the Write. The input data setup and hold timing should be referenced to the leading edge of the signal that terminates the Write.
- The minimum Write cycle time for Write Cycle No. 2 (\overline{WE} controlled, \overline{OE} LOW) is the sum of t_{HZWE} and t_{SD} .

Data Retention Waveform

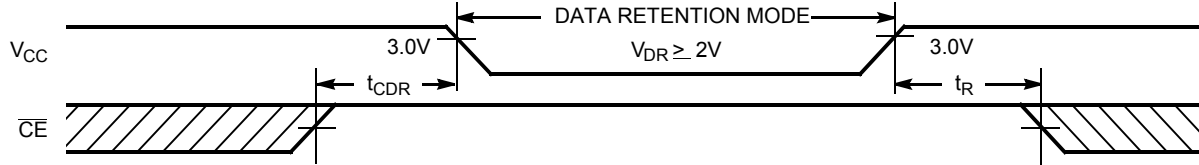

Switching Waveforms

Read Cycle No. 1 (Address Transition Controlled) [12, 13]

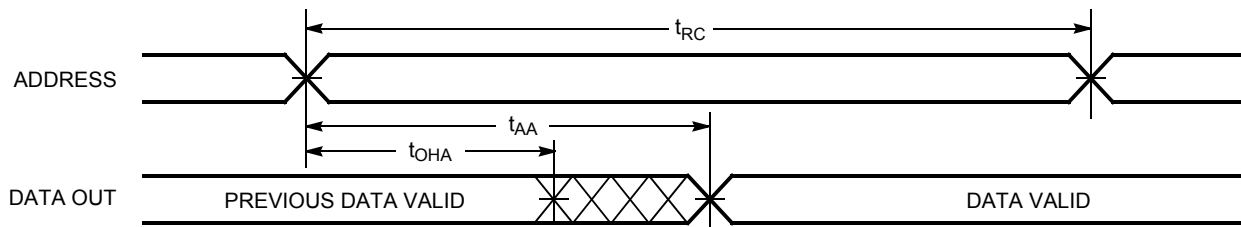

Read Cycle No. 2 (\overline{OE} Controlled) [13, 14]

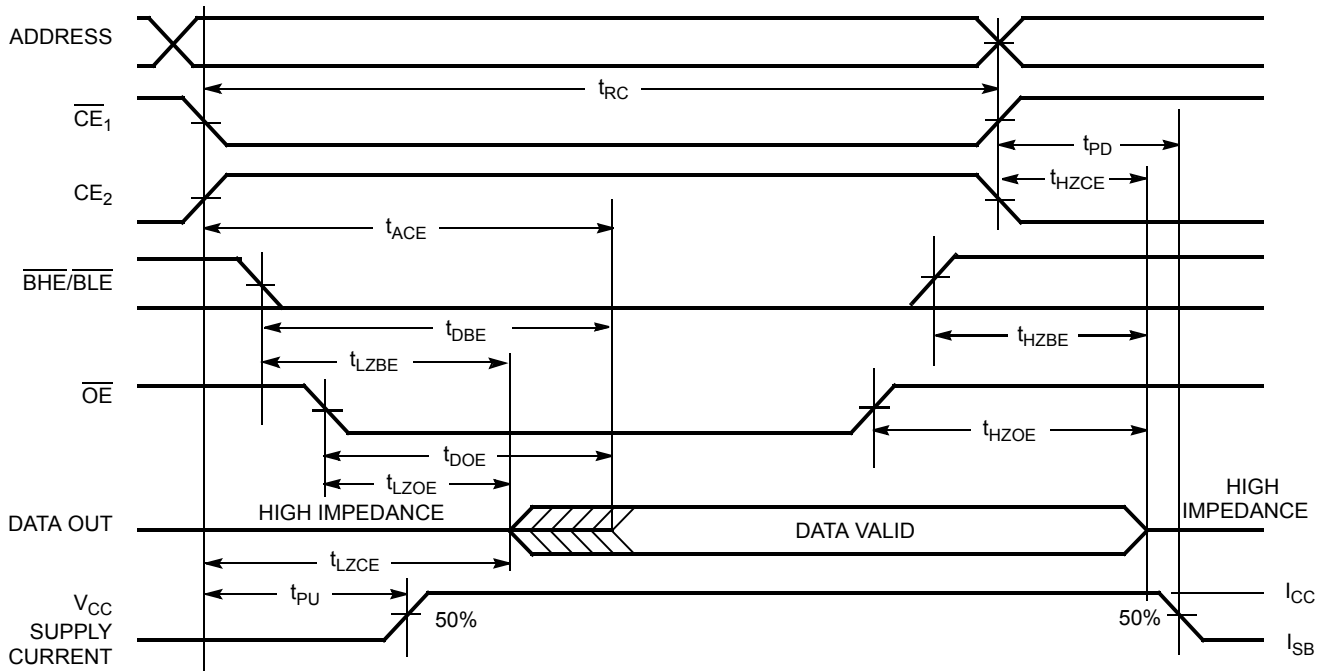

Notes

- 12. Device is continuously selected. \overline{OE} , \overline{CE} , \overline{BHE} or \overline{BHE} , or both = V_{IL} . $CE2 = V_{IH}$.
- 13. \overline{WE} is HIGH for Read cycle.
- 14. Address valid prior to or coincident with \overline{CE}_1 transition LOW and CE_2 transition HIGH.

Switching Waveforms (continued)

Write Cycle No. 1 (\overline{CE}_1 or CE_2 Controlled) [15, 16]

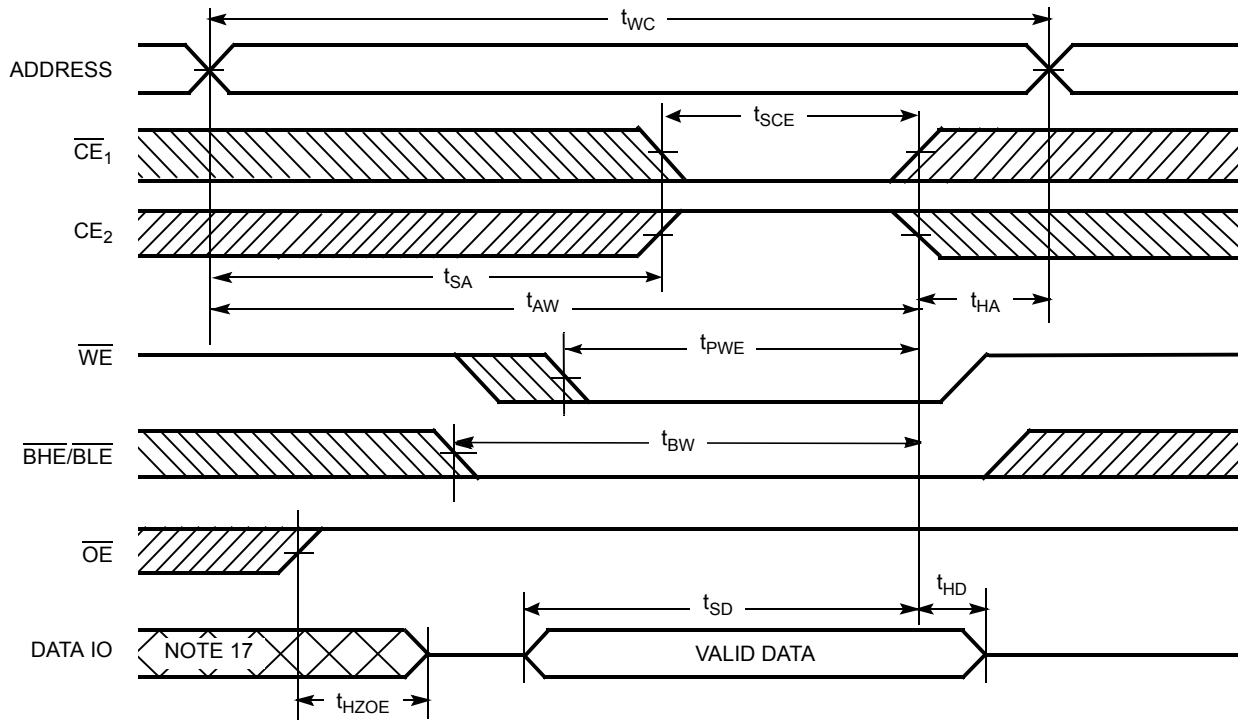

Write Cycle No. 2 (\overline{WE} Controlled, \overline{OE} LOW) [15, 16]

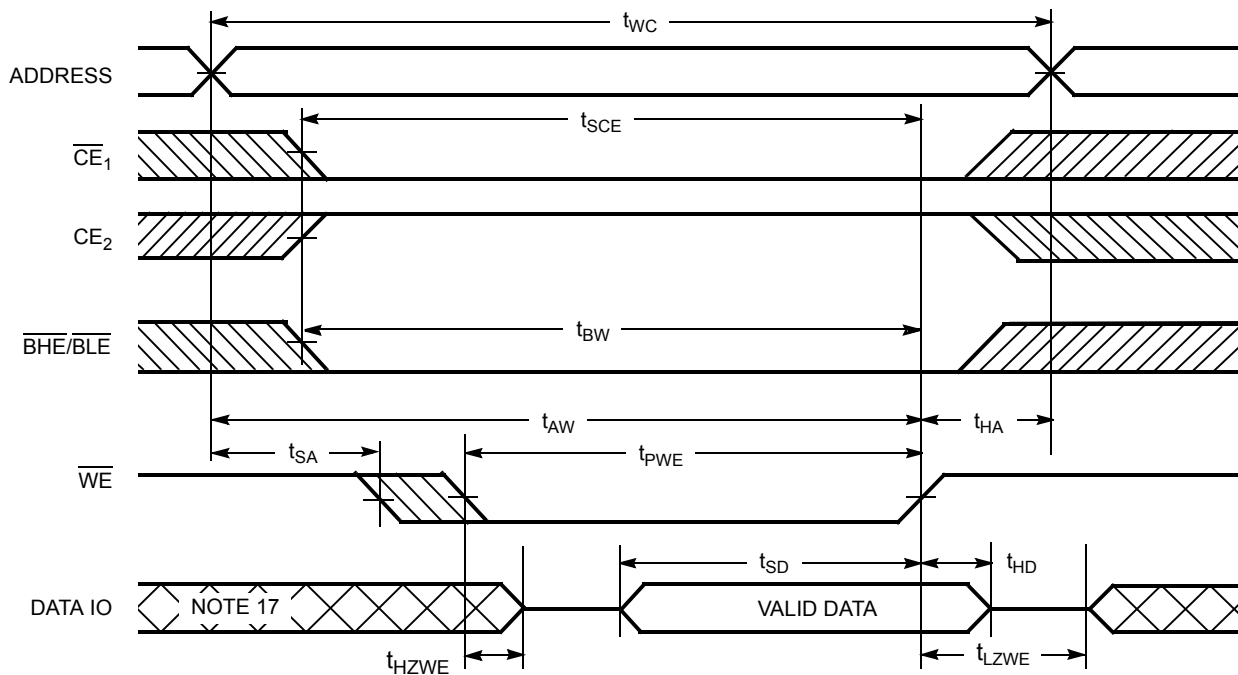

Notes

- 15. Data IO is high impedance if \overline{OE} , or \overline{BHE} or \overline{BLE} or both = V_{IH} .
- 16. If \overline{CE}_1 goes HIGH simultaneously with \overline{WE} going HIGH, the output remains in a high impedance state.
- 17. During this period, the IOs are in output state and input signals should not be applied.

Switching Waveforms (continued)

Write Cycle No. 3 ($\overline{\text{BHE}}/\overline{\text{BLE}}$ Controlled)

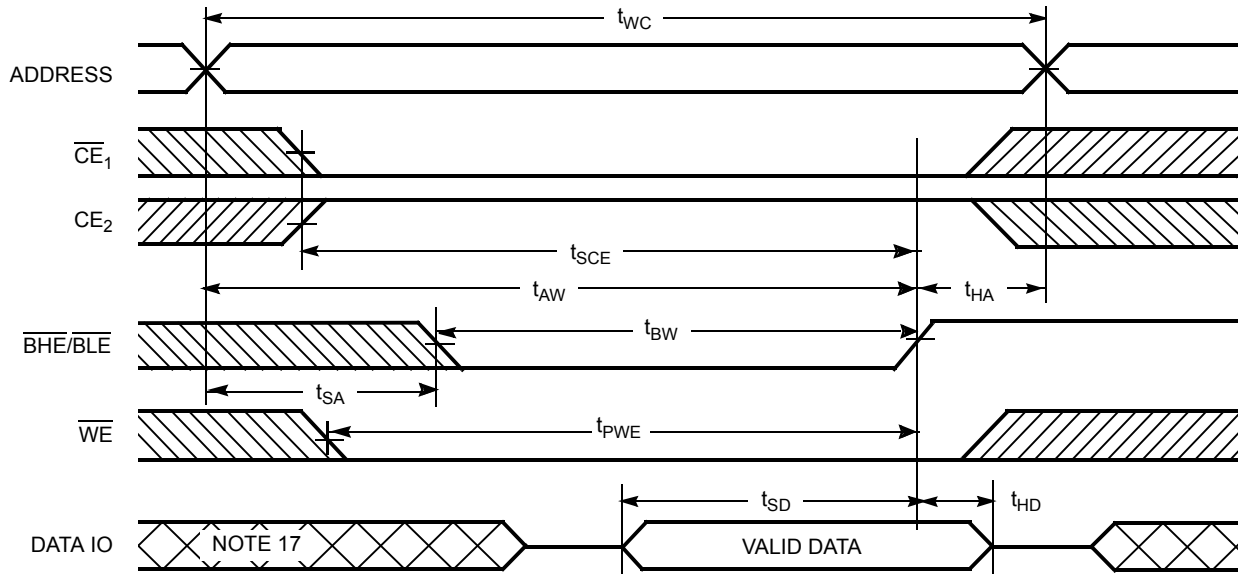

Truth Table

$\overline{\text{CE}}_1$	$\overline{\text{CE}}_2$	$\overline{\text{OE}}$	$\overline{\text{WE}}$	$\overline{\text{BLE}}$	$\overline{\text{BHE}}$	$\text{IO}_0\text{-IO}_7$	$\text{IO}_8\text{-IO}_{15}$	Mode	Power
H	X	X	X	X	X	High-Z	High-Z	Power Down	Standby (I_{SB})
X	L	X	X	X	X	High-Z	High-Z	Power Down	Standby (I_{SB})
L	H	L	H	L	L	Data Out	Data Out	Read All Bits	Active (I_{CC})
L	H	L	H	L	H	Data Out	High-Z	Read Lower Bits Only	Active (I_{CC})
L	H	L	H	H	L	High-Z	Data Out	Read Upper Bits Only	Active (I_{CC})
L	H	X	L	L	L	Data In	Data In	Write All Bits	Active (I_{CC})
L	H	X	L	L	H	Data In	High-Z	Write Lower Bits Only	Active (I_{CC})
L	H	X	L	H	L	High-Z	Data In	Write Upper Bits Only	Active (I_{CC})
L	H	H	H	X	X	High-Z	High-Z	Selected, Outputs Disabled	Active (I_{CC})

Ordering Information

Speed (ns)	Ordering Code	Package Diagram	Package Type	Operating Range
10	CY7C1061AV33-10ZXC	51-85160	54-pin TSOP II (Pb-free)	Commercial
	CY7C1061AV33-10BAC	51-85162	60-ball FBGA	
	CY7C1061AV33-10ZI	51-85160	54-pin TSOP II	Industrial
	CY7C1061AV33-10ZXI		54-pin TSOP II (Pb-free)	
	CY7C1061AV33-10BAXI	51-85162	60-ball FBGA (Pb-free)	
12	CY7C1061AV33-12ZC	51-85160	54-pin TSOP II	Commercial
	CY7C1061AV33-12ZXC		54-pin TSOP II (Pb-free)	
	CY7C1061AV33-12BAC	51-85162	60-ball FBGA	
	CY7C1061AV33-12ZXI	51-85160	54-pin TSOP II (Pb-free)	Industrial

Contact local Cypress representative for availability of the these parts.

Package Diagrams

Figure 1. 54-pin TSOP II, 51-85160

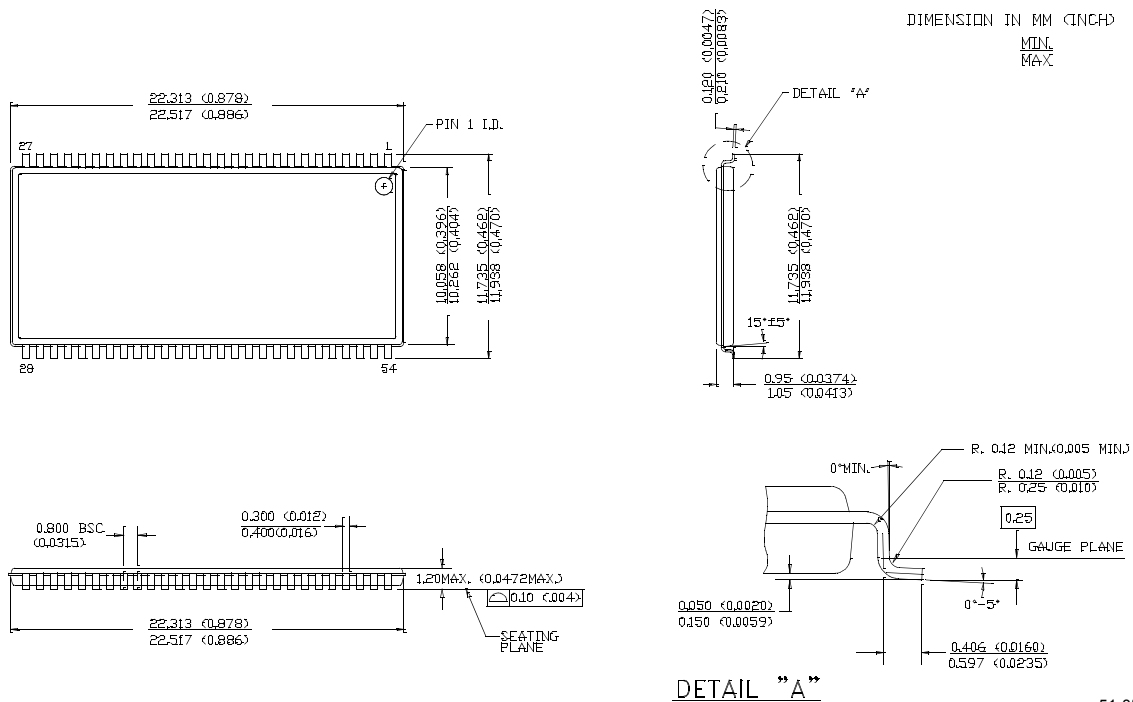

51-85160-**

Package Diagrams (continued)

Figure 2. 60-ball FBGA (8 x 20 x 1.2 mm), 51-85162

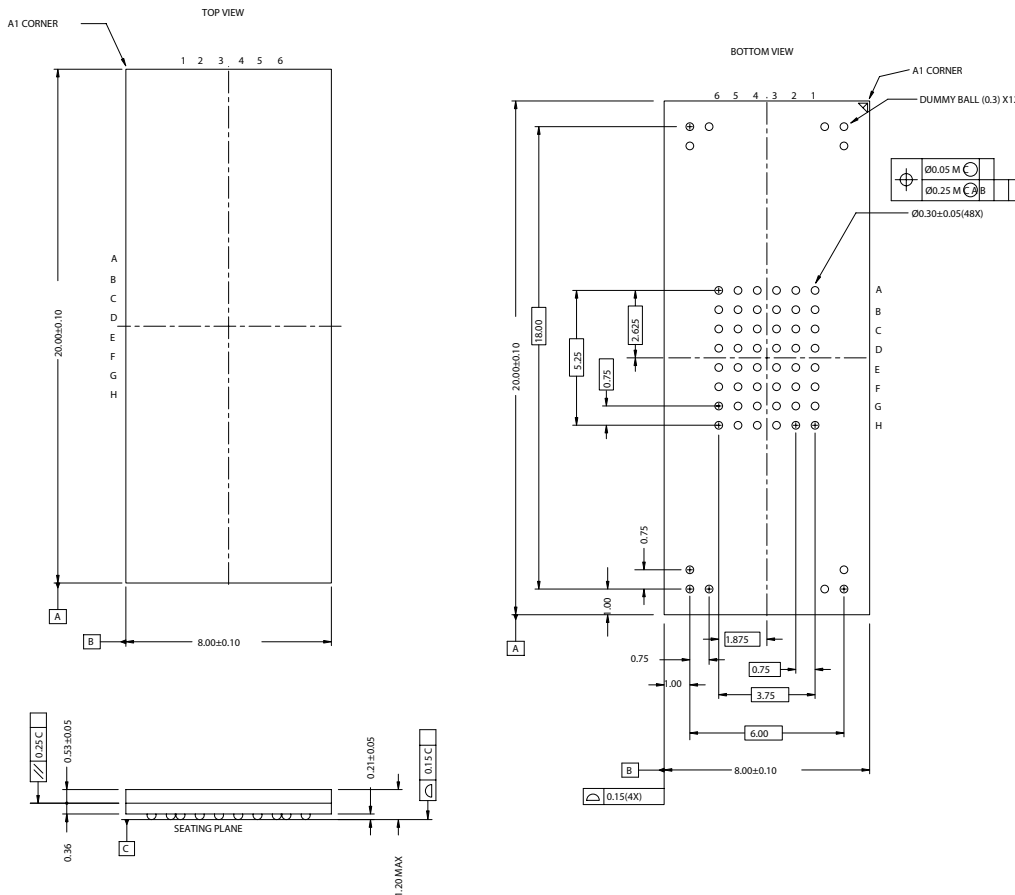

DIMENSIONS IN MM

PART #	
BA60A	STANDARD PKG.
BK60A	LEAD FREE PKG.

PKG WEIGHT: 0.30 gms

51-85162-*D

All products and company names mentioned in this document may be the trademarks of their respective holders.

Document History Page

Document Title: CY7C1061AV33 16-Mbit (1M x 16) Static RAM				
Document Number: 38-05256				
REV.	ECN NO.	Issue Date	Orig. of Change	Description of Change
**	113725	03/28/02	NSL	New Data Sheet
*A	117058	07/31/02	DFP	Removed 15-ns bin
*B	117989	08/30/02	DFP	Added 8-ns bin Changed I _{cc} for 8, 10, 12 bins t _{power} changed from 1 μs to 1 ms. Load Cap Comment changed (for Tx line load) t _{SD} changed to 5.5 ns for the 10-ns bin Changed some 8-ns bin numbers (t _{HZ} , t _{DOE} , t _{DBE}) Removed hz<lz comments from data sheet
*C	120383	11/06/02	DFP	Final data sheet Added note 3 to "AC Test Loads and Waveforms" and note 7 to t _{pu} and t _{pd} Updated Input/Output Caps (for 48BGA only) to 8 pF/10 pF and for the 54-pin TSOP to 6/8 pF
*D	124439	2/25/03	MEG	Changed ISB1 from 100 mA to 70 mA Shaded fBGA production ordering information
*E	492137	See ECN	NXR	Corrected Block Diagram on page #1 Removed 8 ns speed bin Changed 48-Ball FBGA to 60-Ball FBGA in Pin Configuration Included Note #1 and 2 on page #2 Changed the description of I _{I_X} from Input Load Current to Input Leakage Current in DC Electrical Characteristics table Updated the Ordering Information Table
*F	508117	See ECN	NXR	Updated FBGA Pin Configuration Updated Ordering Information table
*G	877322	See ECN	VKN	Updated Ordering Information table

Looking for pricing, stock, or lifecycle information?

Click below to explore more details on WIN SOURCE:

 [View CY7C1061AV33-10ZXIT on WIN SOURCE](#)

 [Infineon Technologies](#) Information

Optimize Your Supply Chain with WIN SOURCE Solutions

-  Global Sourcing Solution
-  Obsolete Management
-  Cost Control Management
-  Shortage Management
-  Alternative Solution
-  Excess Inventory Management