



**THE DATASHEET OF
BLA2ABD221SN4D**



Chip Ferrite Bead Array BLA2A□□□□SN4□ Reference Specification

1. Scope

This reference specification is applied to Chip Ferrite Bead Array BLA2A Series used for electronic machinery.

2. Part Numbering

(ex.) BL A 2A AG 121 S N 4 D
 (1) Product ID (2) Type (3) Dimension (L×W)
 (4) Characteristics (5) Typical Impedance at 100MHz (6) Performance
 (7) Category (8) Numbers of Circuit (9) Packaging (D : Taping / B : Bulk)

3. Rating

Customer Part Number	MURATA Part Number	Impedance (Ω) at 100MHz, (Under Standard Testing Condition)	Rated Current (mA)	DC Resistance (Ω max.)		Insulation Resistance between Elements	Remark
				Initial Values	Values After Testing		
	BLA2AAG121SN4D BLA2AAG121SN4B	120 ± 25 %	100	0.5	0.6	100MΩ min.	For general use
	BLA2AAG221SN4D BLA2AAG221SN4B	220 ± 25 %	50	0.7	0.8		
	BLA2AAG601SN4D BLA2AAG601SN4B	600 ± 25 %		1.1	1.2		
	BLA2AAG102SN4D BLA2AAG102SN4B	1000 ± 25 %	1.3	1.4			
	BLA2ABB100SN4D BLA2ABB100SN4B	10 ± 25 %	200	0.1	0.2		
	BLA2ABB220SN4D BLA2ABB220SN4B	22 ± 25 %		0.2	0.3		
	BLA2ABB470SN4D BLA2ABB470SN4B	47 ± 25 %		0.35	0.45		
	BLA2ABB121SN4D BLA2ABB121SN4B	120 ± 25 %	50	0.6	0.7		For high speed signal Line
	BLA2ABB221SN4D BLA2ABB221SN4B	220 ± 25 %		0.9	1.0		
	BLA2ABD750SN4D BLA2ABD750SN4B	75 ± 25 %	200	0.20	0.30		
	BLA2ABD121SN4D BLA2ABD121SN4B	120 ± 25 %		0.35	0.45		
	BLA2ABD221SN4D BLA2ABD221SN4B	220 ± 25 %	100	0.40	0.50		
	BLA2ABD471SN4D BLA2ABD471SN4B	470 ± 25 %		0.65	0.75		
	BLA2ABD601SN4D BLA2ABD601SN4B	600 ± 25 %		0.80	0.90		
	BLA2ABD102SN4D BLA2ABD102SN4B	1000 ± 25 %	50	1.00	1.10		

• Operating Temperature: - 55 °C to + 125 °C

• Storage Temperature: - 55 °C to + 125 °C

4. Style and Dimensions

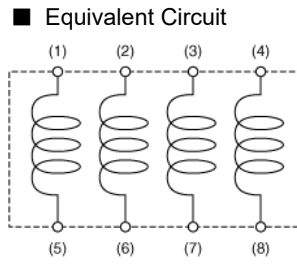
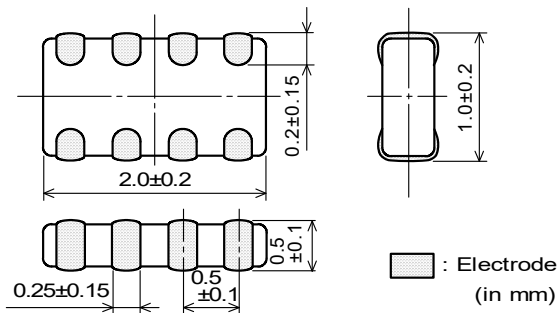

No polarity

■ Unit Mass (Typical value)
0.005g

5. Marking

No marking.

6. Standard Testing Conditions

< Unless otherwise specified >

Temperature : Ordinary Temp. 15 °C to 35 °C

Humidity: Ordinary Humidity 25 %(RH) to 85 %(RH)

< In case of doubt >

Temperature: 20 °C ± 2 °C

Humidity: 60 %(RH) to 70 %(RH)

Atmospheric pressure: 86 kPa to 106 kPa

7. Electrical Performance

No.	Item	Specification	Test Method
7.1	Impedance	Meet item 3.	Measuring Frequency : 100 MHz ± 1 MHz Measuring Equipment : KEYSIGHT 4291A or the equivalent (OSC = 0.05 V) Test Fixture : KEYSIGHT 16192A
7.2	DC Resistance	Meet item 3.	Measuring Equipment : Digital multi meter * Except resistance of the Substrate and Wire
7.3	Insulation Resistance between Elements	Meet item 3.	Measuring Voltage : 5 V(DC) Measuring Time : 1 min max.

8. Mechanical Performance

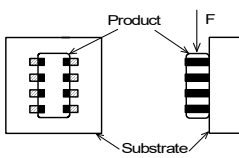
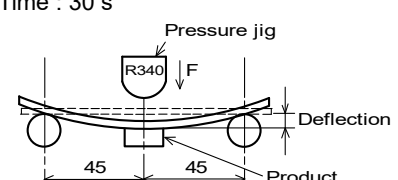
No.	Item	Specification	Test Method				
8.1	Appearance and Dimensions	Meet item 4.	Visual Inspection and measured with Slide Calipers or Micrometer or Measuring Microscope.				
8.2	Bonding Strength	Meet Table 1. <table border="1"> <thead> <tr> <th>Appearance</th> <th>No damage</th> </tr> </thead> <tbody> <tr> <td>Impedance Change (at 100MHz)</td> <td>Within ± 30 %</td> </tr> </tbody> </table>	Appearance	No damage	Impedance Change (at 100MHz)	Within ± 30 %	It shall be soldered on the substrate. Applying Force(F) : 9.8 N Applying Time : 5 s ± 1 s 
Appearance	No damage						
Impedance Change (at 100MHz)	Within ± 30 %						
8.3	Bending Strength	DC Resistance Meet item 3.	It shall be soldered on the substrate. Substrate : Glass-epoxy substrate (100mm × 40mm × 1.0mm) Deflection : 2.0 mm Speed of Applying Force : 0.5 mm / s Keeping Time : 30 s 				

No.	Item	Specification	Test Method
8.4	Solderability	The electrodes shall be at least 95 % covered with new solder coating.	Flux : Ethanol solution of rosin, 25 (wt)% Pre-Heating : 150 °C ± 10 °C, 60 s ~ 90 s Solder :Sn-3.0Ag-0.5Cu Solder Temperature : 240 °C ± 5 °C Immersion Time : 3 s ± 1 s Immersion and emersion rates : 25 mm / s
8.5	Resistance to Soldering Heat	Meet Table 1.	Flux : Ethanol solution of rosin, 25 (wt)% Pre-Heating : 150 °C ± 10 °C, 60 s ~ 90 s Solder : Sn-3.0Ag-0.5Cu Solder Temperature : 270 °C ± 5 °C Immersion Time : 10 s ± 1 s Immersion and emersion rates : 25 mm / s Then measured after exposure in the room condition for 48 h ± 4 h.
8.6	Vibration		It shall be soldered on the substrate. Oscillation Frequency : 10Hz to 55Hz to 10Hz for 1 min Total Amplitude : 1.5 mm Testing Time : A period of 2 hours in each of 3 mutually erpendicular directions.
8.7	Drop	Product shall be no failure after tested.	It shall be dropped on concrete or steel board. Method : free fall Height : 75 cm Attitude from which the product is dropped : 3 directions The Number of Time : 3 times for each direction (Total 9 times)

9. Environmental Performance (It shall be soldered on the substrate.)

No.	Item	Specification	Test Method
9.1	Temperature Cycle	Meet Table 1.	1 cycle 1 step : -55 °C (+0 °C , -3 °C) / 30min ± 3min 2 step: Ordinary temp. / 10min to 15min 3 step : +125 °C (+3 °C , -0 °C) / 30min ± 3min 4 step: Ordinary temp. / 10min to 15min Total of 100 cycles Then measured after exposure in the room condition for 48 h ± 4 h.
9.2	Humidity		Temperature : 40 °C ± 2 °C Humidity : 90 %(RH) to 95 %(RH) Time : 1000 h (+48 h , -0 h) Then measured after exposure in the room condition for 48 h ± 4 h.
9.3	Heat Life		Temperature : 125 C ± 3 °C Applying Current : Rated Current Time : 1000 h (+48 h , -0 h) Then measured after exposure in the room condition for 48 h ± 4 h.
9.4	Cold Resistance		Temperature : - 55 °C ± 2 °C Time : 1000 h (+48 h , -0 h) Then measured after exposure in the room condition for 48 h ± 4 h.

10. Specification of Packaging

10.1. Appearance and Dimensions (8 mm-wide paper tape)

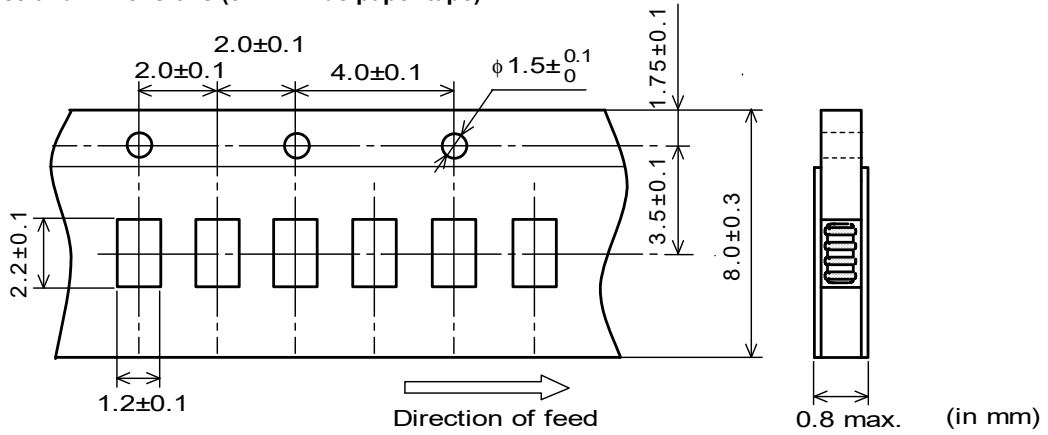

- (1) Taping
Products shall be packaged in the cavity of the base tape of 8 mm-wide , 2 mm-pitch continuously and sealed by top tape and bottom tape.
- (2) The sprocket holes are to the right as the tape is pulled toward the user.
- (3) Splice point : The base tape and top tape have no spliced point
- (4) Cavity : There shall not be burr in the cavity.
- (5) Missing components number
Missing components number within 0.025% of the number per reel or 1 pc., whichever is greater, and are not continuous. The specified quantity per reel is kept.

10.2. Tape Strength

- (1) Pull Strength

Top tape	5N min.
Bottom tape	

- (2) Peeling off force of Top tape
0.1N to 0.6N (Minimum value is typical.)
* Speed of Peeling off : 300 mm / min

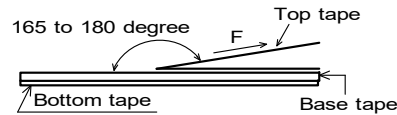

10.3. Taping Condition

- (1) Standard quantity per reel
Quantity per 180 mm reel : 10000 pcs. / reel
- (2) There shall be leader-tape (top tape and empty tape) and trailer-tape (empty tape) as follows.
- (3) On paper tape, the top tape and the base tape shall no be adhered at the tip of the empty leader tape for more than 5 pitch.
- (4) Marking for reel

The following items shall be marked on a label and the label is stuck on the reel.
(Customer part number, MURATA part number, Inspection number(*1), RoHS discrimination(*2), Quantity, etc)

*1) « Expression of Inspection No. » □□ 0000 XXX
 (1) (2) (3)

(1) Factory Code
(2) Date First digit : Year / Last digit of year
 Second digit : Month / Jan. to Sep. → 1 to 9, Oct. to Dec. → O, N, D
 Third, Fourth digit : Day
(3) Serial No.

*2) « Expression of RoHS discrimination » ROHS - Y (Δ)
 (1) (2)

- (1) RoHS regulation conformity parts.
- (2) MURATA classification number

(5) Outside package

These reels shall be packed in the corrugated cardboard package and the following items shall be marked on a label and the label is stuck on the box.

(Customer name, Purchasing Order Number, Customer Part Number, MURATA part number, RoHS discrimination(*2), Quantity, etc)

(6) Dimensions of reel and taping (leader-tape, trailer-tape)

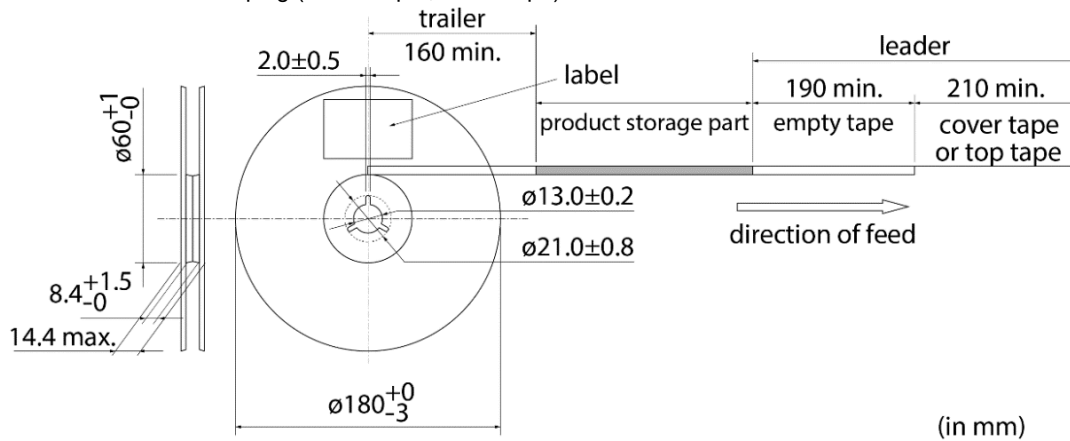

10-4. Specification of Outer Case

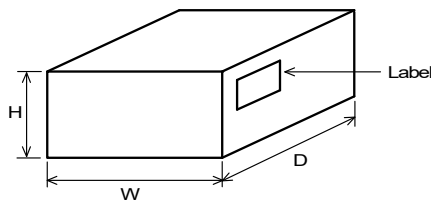

Outer Case Dimensions (mm)			Standard Reel Quantity in Outer Case (Reel)
W	D	H	
186	186	93	5

* Above Outer Case size is typical. It depends on a quantity of an order.

11.  Caution

11.1. Surge current

Excessive surge current (pulse current or rush current) than specified rated current applied to the product may cause a critical failure, such as an open circuit, burnout caused by excessive temperature rise.

Please contact us in advance in case of applying the surge current.

11.2. Limitation of Applications

Please contact us before using our products for the applications listed below which require especially high reliability for the prevention of defects which might directly cause damage to the third party's life, body or property.

- | | |
|-----------------------------------|--|
| (1) Aircraft equipment | (6) Disaster prevention / crime prevention equipment |
| (2) Aerospace equipment | (7) Traffic signal equipment |
| (3) Undersea equipment | (8) Transportation equipment (vehicles, trains, ships, etc.) |
| (4) Power plant control equipment | (9) Data-processing equipment |
| (5) Medical equipment | (10) Application of similar complexity and/or with reliability Requirements to the applications listed in the above. |

11.3. Corrosive gas

Please refrain from use since contact with environments with corrosive gases (sulfur gas [hydrogen sulfide, sulfur dioxide, etc.], chlorine, ammonia, etc.) or oils (cutting oil, silicone oil, etc.) that have come into contact with the previously stated corrosive gas environment will result in deterioration of product quality or an open from deterioration due to corrosion of product electrode, etc. We will not bear any responsibility for use under these environments.

12. Notice

This product is designed for solder mounting.
Please consult us in advance for applying other mounting method such as conductive adhesive.

12.1. Land pattern designing

· Standard land dimensions (Reflow soldering)

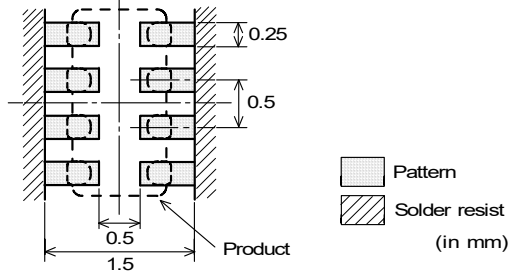

* The excessive heat by land pads may cause deterioration at joint of products with substrate.

12.2. Soldering Conditions

Products can be applied to reflow soldering.

(1) Flux , Solder

Flux	Use rosin-based flux, but not highly acidic flux (with chlorine content exceeding 0.2(wt)% .) Do not use water-soluble flux.
Solder	Use Sn-3.0Ag-0.5Cu solder Standard thickness of solder paste : 100 μm to 200 μm Use of Sn-Zn based solder will deteriorate performance of products. In case of using Sn-Zn based solder, please contact Murata in advance.

(2) Soldering conditions

· Pre-heating should be in such a way that the temperature difference between solder and ferrite surface is limited to 150°C max. Also cooling into solvent after soldering should be in such a way that the temperature difference is limited to 100 °C max.

Insufficient pre-heating may cause cracks on the ferrite, resulting in the deterioration of product quality.

· Standard soldering profile and the limit soldering profile is as follows.

The excessive limit soldering conditions may cause leaching of the electrode and / or resulting in the deterioration of product quality.

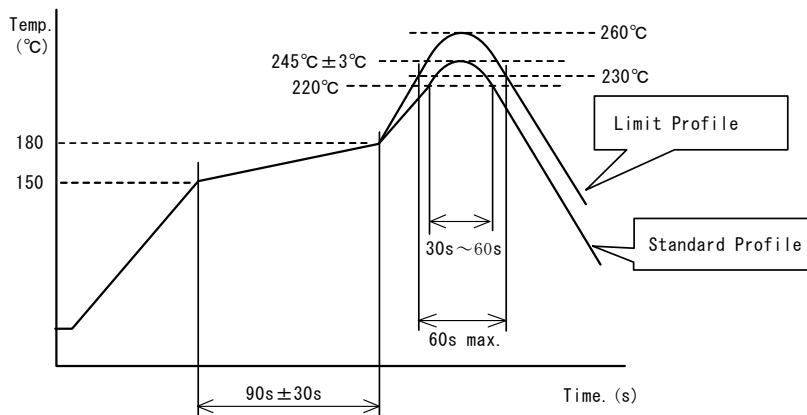

	Standard Profile	Limit Profile
Pre-heating	150~180°C , 90s±30s	
Heating	above 220°C、30s~60s	above 230°C、60s max.
Peak temperature	245±3°C	260°C,10s
Cycle of reflow	2 times	2 times

12.3. Reworking with soldering iron

- Pre-heating : 150 °C , 1 min
- Tip temperature: 350°C max.
- Soldering time : 3(+1,-0) seconds.
- Soldering iron output : 80W max.
- Tip diameter: φ 3mm max.
- Times : 2times max.

Note : Do not directly touch the products with the tip of the soldering iron in order to prevent the crack on the ferrite material due to the thermal shock.

12.4. Solder Volume

Solder shall be used not to be exceeded as shown below.
Accordingly increasing the solder volume, the mechanical stress to product is also increased.
Exceeding solder volume may cause the failure of mechanical or electrical performance.

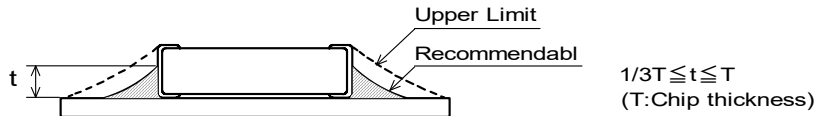

12.5. Attention regarding P.C.B bending

The following shall be considered when designing and laying out P.C.B.'s

- (1) P.C.B. shall be designed so that products are not subject to the mechanical stress for board warpage.

<Products direction>

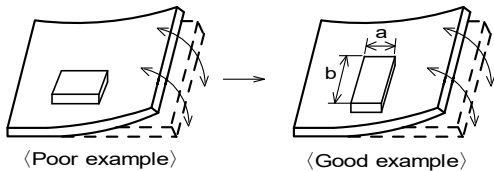

Products shall be located in the sideways direction (Length : a < b) to the mechanical stress.

- (2) Components location on P.C.B. separation.

It is effective to implement the following measures, to reduce stress in separating the board.
It is best to implement all of the following three measures; however, implement as many measures as possible to reduce stress.

Contents of Measures	Stress Level
(1) Turn the mounting direction of the component parallel to the board separation surface.	A > D *1
(2) Add slits in the board separation part.	A > B
(3) Keep the mounting position of the component away from the board separation surface.	A > C

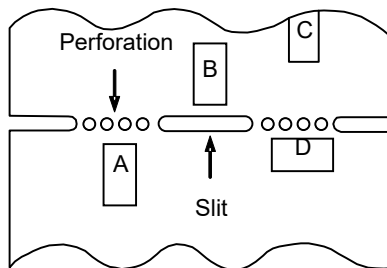

*1 A > D is valid when stress is added vertically to the perforation as with Hand Separation.
If a Cutting Disc is used, stress will be diagonal to the PCB, therefore A > D is invalid.

- (3) Mounting Components Near Screw Holes

When a component is mounted near a screw hole, it may be affected by the board deflection that occurs during the tightening of the screw. Mount the component in a position as far away from the screw holes as possible.

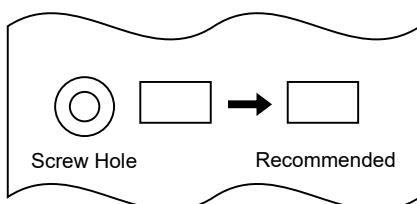

12.6. Potential between Elements

Products should be used within 5 V(DC) between elements.

When the products are used the excessive voltage over 5 V(DC) , it may cause breaking of inner electrode and / or decreasing o insulation resistance between elements.

12.7. Mounting density

Add special attention to radiating heat of products when mounting the inductor near the products with heating. The excessive heat by other products may cause deterioration at joint of this product with substrate.

12.8. Cleaning

Excessive ultrasonic oscillation during cleaning can cause the PCBs to resonate, resulting in cracked chips or broken solder joints. Before starting your production process, test your cleaning equipment / process to insure it does not degrade this product.

12.9. Handling of a substrate

After mounting products on a substrate, do not apply any stress to the product caused by bending or twisting to the substrate when cropping the substrate, inserting and removing a connector from the substrate or tightening screw to the substrate.

Excessive mechanical stress may cause cracking in the product.

**12.10. Operating Environment**

Do not use this product under the following environmental conditions, on deterioration of the Insulation Resistance of the Ferrite material and/or corrosion of Inner Electrode may result from the use.

- (1) In the corrodible atmosphere such as acidic gases, alkaline gases, chlorine, sulfur gases, organic gases and etc.
(the sea breeze, Cl₂, H₂S, NH₃, SO₂, NO₂,etc)
- (2) In the atmosphere where liquid such as organic solvent, may splash on the products.
- (3) In the atmosphere where the temperature / humidity changes rapidly and it is easy to dew.

12.11. Resin coating

The impedance value may change and/or it may affect on the product's performance due to high cure-stress of resin to be used for coating / molding products. So please pay your careful attention when you select resin. In prior to use, please make the reliability evaluation with the product mounted in your application set.

12.12. Storage Conditions**(1) Storage period**

Use the products within 6 months after delivered.

Solderability should be checked if this period is exceeded.

(2) Storage coditions

· Products should be stored in the warehouse on the following conditions.

Temperature : - 10 °C to 40 °C

Humidity : 15 % to 85 % relative humidity

No rapid change on temperature and humidity

· Don't keep products in corrosive gases such as sulfur, chlorine gas or acid, or it may cause oxidization of electrode, resulting in poor solderability.

· Products should be stored on the palette for the prevention of the influence from humidity, dust and so on.

· Products should be stored in the warehouse without heat shock, vibration, direct sunlight and so on.

· Avoid storing the product by itself bare (i.e. exposed directly to air).

(3) Delivery

Care should be taken when transporting or handling product to avoid excessive vibration or mechanical shock.

13.  Notes

- (1) Please make sure that your product has been evaluated in view of your specifications with our product being mounted to your product.
- (2) You are requested not to use our product deviating from the reference specifications.
- (3) The contents of this reference specification are subject to change without advance notice. Please approve our product specifications or transact the approval sheet for product specifications before ordering.

Looking for pricing, stock, or lifecycle information?

Click below to explore more details on WIN SOURCE:

- ⊖ [View BLA2ABD221SN4D on WIN SOURCE](#)
- ⊖ [Murata Electronics North America Information](#)

Optimize Your Supply Chain with WIN SOURCE Solutions

- ✓ Global Sourcing Solution
- ✓ Obsolete Management
- ✓ Cost Control Management
- ✓ Shortage Management
- ✓ Alternative Solution
- ✓ Excess Inventory Management