



**THE DATASHEET OF
MT48V4M32LFF5-8:G**



Mobile SDRAM

MT48LC8M16LF, MT48V8M16LF, MT48LC4M32LF, MT48V4M32LF

Features

- Temperature-compensated self refresh (TCSR)
- Fully synchronous; all signals registered on positive edge of system clock
- Internal pipelined operation; column address can be changed every clock cycle
- Internal banks for hiding row access/precharge
- Programmable burst lengths: 1, 2, 4, 8, or full page
- Auto precharge, includes concurrent auto precharge, and auto refresh modes
- Self refresh mode; standard and low power (not available on AT devices)
- Auto refresh
 - 64ms, 4,096-cycle refresh (15.6µs/row) (commercial and industrial)
 - 16ms, 4,096-cycle refresh (3.9µs/row) (automotive)
- LVTTTL-compatible inputs and outputs
- Low voltage power supply
- Partial-array self refresh (PASR) power-saving mode

Table 1: Key Timing Parameters
CL = CAS (READ) latency

Speed Grade	Clock Frequency	Access Time			t _{RCD}	t _{RP}
		CL = 1	CL = 2	CL = 3		
-75M	133 MHz	–	–	5.4	19ns	19ns
-8	125 MHz	–	–	7ns	20ns	20ns
-10	100 MHz	–	–	7ns	20ns	20ns
-75M	100 MHz	–	6	–	19ns	19ns
-8	100 MHz	–	8ns	–	20ns	20ns
-10	83 MHz	–	8ns	–	20ns	20ns
-8	50 MHz	19ns	–	–	20ns	20ns
-10	40 MHz	22ns	–	–	20ns	20ns

Options

- V_{DD}/V_{DDQ}
 - 3.3V/3.3V LC
 - 2.5V/2.5–1.8V V
- Configurations
 - 8 Meg x 16 (2 Meg x 16 x 4 banks) 8M16
 - 4 Meg x 32 (1 Meg x 32 x 4 banks) 4M32
- Package/ball out
 - 54-ball VFPGA (8mm x 8mm)¹ F4
 - 54-ball VFPGA (8mm x 8mm)¹ Pb-free B4
 - 90-ball VFPGA (8mm x 13mm)² F5
 - 90-ball VFPGA (8mm x 13mm)² Pb-free B5
 - 54-pin TSOP II (400 mil) TG³
 - 54-pin TSOP II (400 mil) Pb-free p³
- Timing (cycle time)
 - 7.5ns @ CL = 3 (133 MHz) -75M³
 - 8ns @ CL = 3 (125 MHz) -8
 - 10ns @ CL = 3 (100 MHz) -10³
- Temperature
 - Commercial (0°C to +70°C) None
 - Industrial (-40°C to +85°C) IT
 - Automotive (-40°C to +105°C) AT³
- Design revision :G

Notes: 1. x16 only.
2. x32 only.
3. Contact Micron for availability.

Table 2: Configurations

	8 Meg x 16	4 Meg x 32
Configuration	2 Meg x 16 x 4 banks	1 Meg x 32 x 4 banks
Refresh count	4K	4K
Row addressing	4K (A0–A11)	4K (A0–A11)
Bank addressing	4 (BA0, BA1)	4 (BA0, BA1)
Column addressing	512 (A0–A8)	256 (A0–A7)

Part Number Example:
MT48V8M16LFB4-8:G

Table of Contents

FBGA Part Marking Decoder	6
General Description	6
Automotive Temperature	7
Pin/Ball Assignments and Descriptions	10
Functional Description	15
Initialization	15
Register Definition	16
Mode Register	16
Burst Length (BL)	17
Burst Type	17
CAS Latency (CL)	19
Write Burst Mode	20
Operating Mode	21
Extended Mode Register	21
Temperature-Compensated Self Refresh (TCSR)	21
Partial-Array Self Refresh (PASR)	22
Commands	23
COMMAND INHIBIT	23
NO OPERATION (NOP)	23
LOAD MODE REGISTER	24
ACTIVE	24
READ	24
WRITE	24
PRECHARGE	24
Auto Precharge	24
BURST TERMINATE	25
AUTO REFRESH	25
SELF REFRESH	25
Operation	26
BANK/ROW ACTIVATION	26
READs	27
WRITEs	35
PRECHARGE	39
POWER-DOWN	39
CLOCK SUSPEND	40
Burst Read/Single Write	41
CONCURRENT Auto Precharge	41
READ with Auto Precharge	41
WRITE with Auto Precharge	42
Electrical Specifications	49
Temperature and Thermal Impedance	49
Notes	57
Timing Diagrams	59
Package Dimensions	78

List of Figures

Figure 2:	Functional Block Diagram 8 Meg x 16 SDRAM	8
Figure 3:	Functional Block Diagram 4 Meg x 32 SDRAM	9
Figure 4:	90-Ball FBGA Pin Assignments (Top View)	10
Figure 5:	54-Pin TSOP Pin Assignments (Top View)	11
Figure 6:	54-Ball VFBGA Pin Assignments (Top View)	11
Figure 7:	Mode Register Definition	18
Figure 8:	CAS Latency	20
Figure 9:	Extended Mode Register	21
Figure 10:	Activating a Specific Row in a Specific Bank	26
Figure 11:	Example: Meeting tRCD (MIN) When $2 < tRCD (MIN)/tCK < 3$	27
Figure 12:	READ Command	27
Figure 13:	CAS Latency	28
Figure 14:	Consecutive READ Bursts	29
Figure 15:	Random READ Accesses	30
Figure 16:	READ-to-WRITE	31
Figure 17:	READ-to-WRITE with Extra Clock Cycle	31
Figure 18:	READ-to-PRECHARGE	33
Figure 19:	Terminating a READ Burst	34
Figure 20:	WRITE Command	35
Figure 21:	WRITE Burst	36
Figure 22:	WRITE-to-WRITE	36
Figure 23:	Random WRITE Cycles	37
Figure 24:	WRITE-to-READ	37
Figure 25:	WRITE-to-PRECHARGE	38
Figure 26:	Terminating a WRITE Burst	38
Figure 27:	PRECHARGE Command	39
Figure 28:	Power-Down	40
Figure 29:	Clock Suspend During WRITE Burst	40
Figure 30:	Clock Suspend During READ Burst	41
Figure 31:	READ With Auto Precharge Interrupted by a READ	42
Figure 32:	READ With Auto Precharge Interrupted by a WRITE	42
Figure 33:	WRITE With Auto Precharge Interrupted by a READ	43
Figure 34:	WRITE With Auto Precharge Interrupted by a WRITE	43
Figure 35:	Example Temperature Test Point Location, 54-Pin TSOP: Top View	51
Figure 36:	Example Temperature Test Point Location, 54-Ball VFBGA: Top View	51
Figure 37:	Example Temperature Test Point Location, 90-Ball VFBGA: Top View	51
Figure 38:	Initialize and Load Mode Register	59
Figure 39:	Power-down Mode	60
Figure 40:	Clock Suspend Mode	61
Figure 41:	Auto Refresh Mode	62
Figure 42:	Self Refresh Mode	63
Figure 43:	READ – Without Auto Precharge	64
Figure 44:	Read – With Auto Precharge	65
Figure 45:	Single Read – Without Auto Precharge	66
Figure 46:	Single Read – With Auto Precharge	67
Figure 47:	Alternating Bank Read Accesses	68
Figure 48:	Read – Full-Page Burst	69
Figure 49:	Read – DQM Operation	70
Figure 50:	Write – Without Auto Precharge	71
Figure 51:	Write – With Auto Precharge	72
Figure 52:	Single Write – Without Auto Precharge	73
Figure 53:	Single Write – With Auto Precharge	74
Figure 54:	Alternating Bank Write Accesses	75
Figure 55:	Write – Full-page Burst	76
Figure 56:	Write – DQM Operation	77
Figure 57:	54-Ball FBGA, “F4/B4” Package (x16 Device), 8mm x 8mm	78

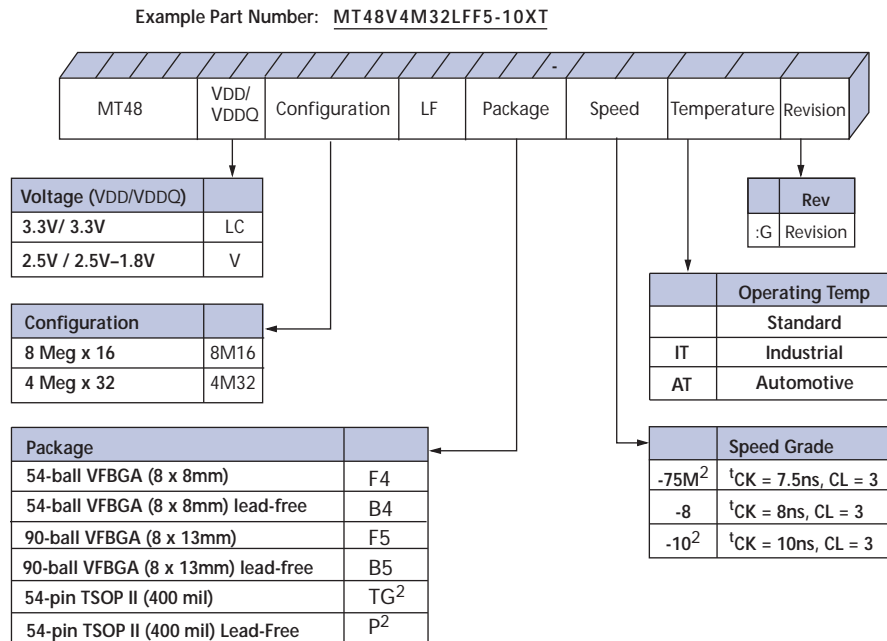

Figure 58: 90-Ball FBGA, "F5/B5" Package (x32 Device), 8mm x 13mm79
Figure 59: 54-Pin Plastic TSOP (400 mil)80

List of Tables

Table 1:	Key Timing Parameters	1
Table 2:	Configurations	1
Table 3:	Ball Descriptions: 54-Ball VFBGA	12
Table 4:	Ball Descriptions: 90-Ball VFBGA	13
Table 5:	Pin Descriptions: 54-Pin TSOP (x16 Only)	14
Table 6:	Burst Definition	19
Table 7:	CAS Latency	20
Table 8:	Truth Table – Commands and DQM Operation	23
Table 9:	Truth Table – CKE	44
Table 10:	Truth Table – Current State Bank <i>n</i> , Command to Bank <i>n</i>	45
Table 11:	Truth Table – CURRENT STATE BANK <i>n</i> , COMMAND tO BANK <i>m</i>	47
Table 12:	Absolute Maximum Ratings	49
Table 13:	Temperature Limits	50
Table 14:	Thermal Impedance Simulated Values	50
Table 15:	DC Electrical Characteristics and Operating Conditions (LC Version)	52
Table 16:	DC Electrical Characteristics and Operating Conditions (V Version)	52
Table 17:	Electrical Characteristics and Recommended AC Operating Conditions	53
Table 18:	AC Functional Characteristics	54
Table 19:	IDD Specifications and Conditions (x16)	55
Table 20:	IDD7 Self Refresh Current Options (x16)	55
Table 21:	IDD Specifications And Conditions (x32)	56
Table 22:	IDD7 Self Refresh Current Options (x32)	56
Table 23:	Capacitance (FBGA Pacakge)	56
Table 24:	Capacitance (TSOP Pacakge)	56

Figure 1: 128Mb SDRAM Part Numbers



- Notes: 1. Not all speeds and configurations are available.
2. Contact Micron for availability.

FBGA Part Marking Decoder

Due to space limitations, FBGA-packaged components have an abbreviated part marking that is different from the part number. Micron's new FBGA Part Marking Decoder makes it easier to understand that part marking. Visit the Web site at www.micron.com/decoder.

General Description

The Micron[®] 128Mb SDRAM device is a high-speed CMOS, dynamic random access memory containing 134,217,728 bits. It is internally configured as a quad-bank DRAM with a synchronous interface (all signals are registered on the positive edge of the clock signal, CLK). Each of the x16's 33,554,432-bit banks is organized as 4,096 rows by 512 columns by 16 bits. Each of the x32's 33,554,432-bit banks is organized as 4,096 rows by 256 columns by 32 bits.

Read and write accesses to the SDRAM are burst oriented; accesses start at a selected location and continue for a programmed number of locations in a programmed sequence. Accesses begin with the registration of an ACTIVE command, which is then followed by a READ or WRITE command. The address bits registered coincident with the ACTIVE command are used to select the bank and row to be accessed (BA0, BA1 select the bank; A0–A11 select the row). The address bits registered coincident with the READ or WRITE command are used to select the starting column location for the burst access.

The SDRAM provides for programmable read or write burst lengths (BL) of 1, 2, 4, or 8 locations, or the full page, with a burst terminate option. An auto precharge function may be enabled to provide a self-timed row precharge that is initiated at the end of the burst sequence.

The 128Mb SDRAM device uses an internal pipelined architecture to achieve high-speed operation. This architecture is compatible with the $2n$ rule of prefetch architectures, but it also enables the column address to be changed on every clock cycle to achieve a high-speed, fully random access. Precharging one bank while accessing one of the other three banks will hide the precharge cycles and provide seamless high-speed, random-access operation.

The 128Mb SDRAM device is designed to operate in 3.3V or 2.5V low-power memory systems. The 2.5V version is compatible with 1.8V I/O interface. An auto refresh mode is provided along with a power-saving, power-down mode. All inputs and outputs are LVTTTL-compatible.

SDRAMs offer substantial advances in DRAM operating performance, including the ability to synchronously burst data at a high data rate with automatic column-address generation, the ability to interleave between internal banks to hide precharge time, and the capability to randomly change column addresses on each clock cycle during a burst access.

Automotive Temperature

The automotive temperature (AT) option adheres to the following specifications:

- 16ms refresh rate
- Self refresh not supported
- Ambient and case temperature cannot be less than -40°C or greater than $+105^{\circ}\text{C}$

Figure 2: Functional Block Diagram 8 Meg x 16 SDRAM

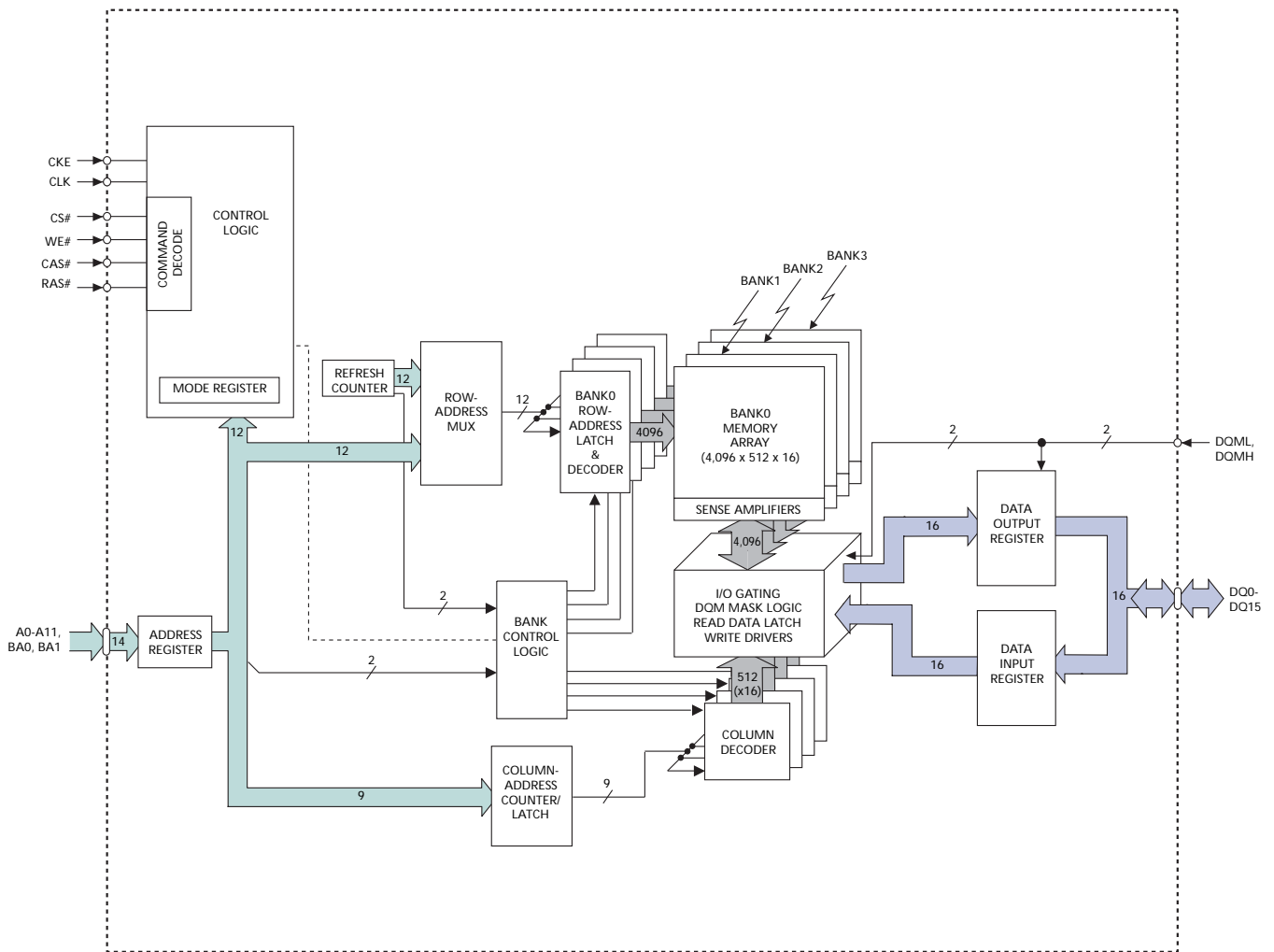
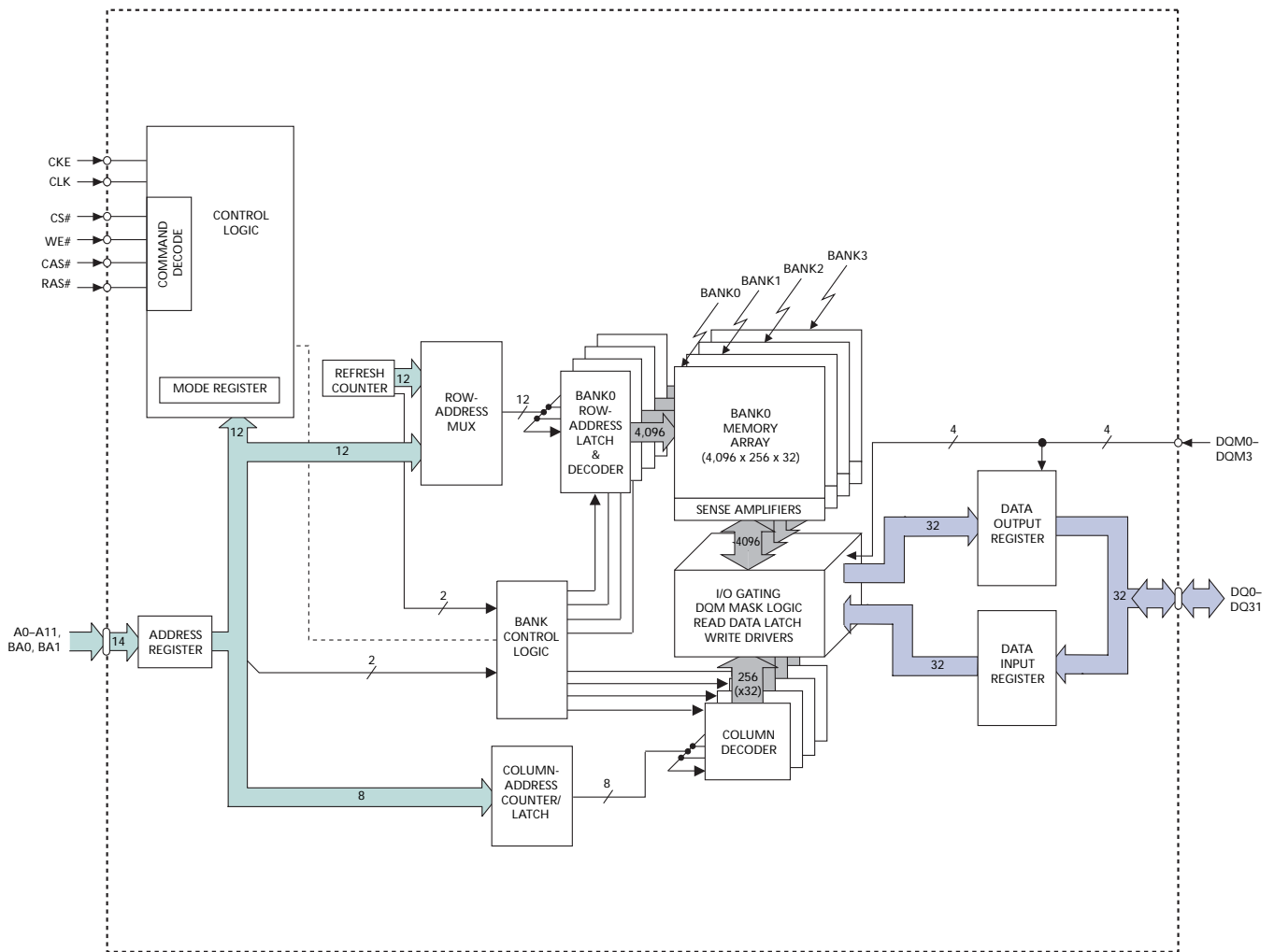

Figure 3: Functional Block Diagram 4 Meg x 32 SDRAM



Pin/Ball Assignments and Descriptions

Figure 4: 90-Ball FBGA Pin Assignments (Top View)

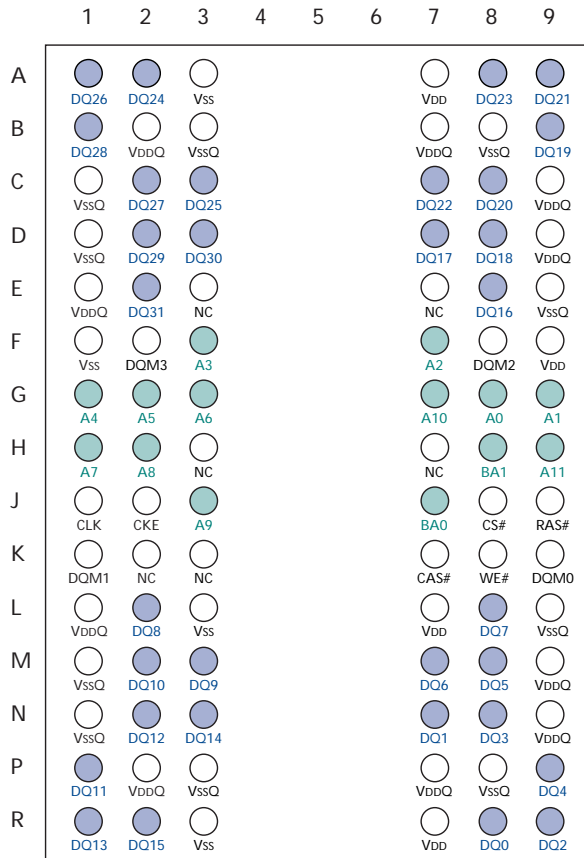
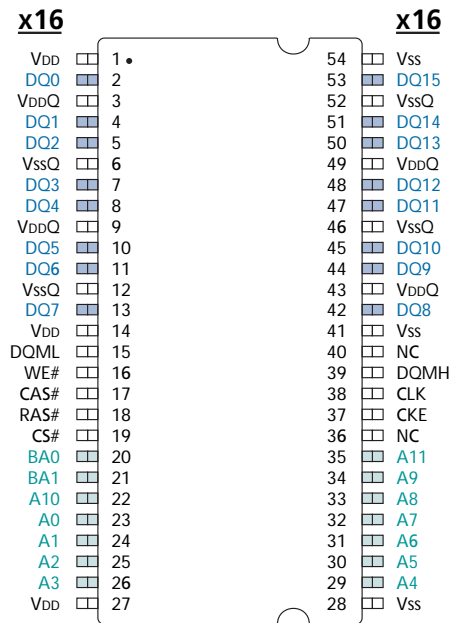

Figure 5: 54-Pin TSOP Pin Assignments (Top View)



Notes: 1. The # symbol indicates signal is active LOW.

Figure 6: 54-Ball VFBGA Pin Assignments (Top View)

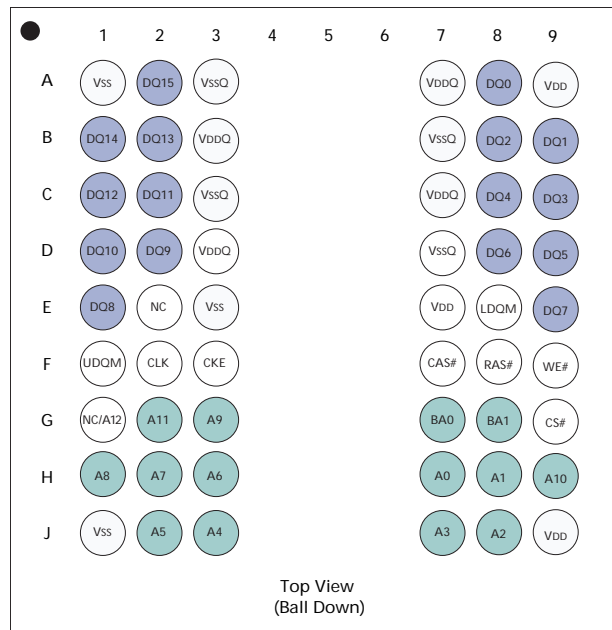

Table 3: Ball Descriptions: 54-Ball VFBGA

54-Ball VFBGA	Symbol	Type	Description
F2	CLK	Input	Clock: CLK is driven by the system clock. All SDRAM input signals are sampled on the positive edge of CLK. CLK also increments the internal burst counter and controls the output registers.
F3	CKE	Input	Clock enable: CKE activates (HIGH) and deactivates (LOW) the CLK signal. Deactivating the clock provides precharge power-down and SELF REFRESH operation (all banks idle), active power-down (row active in any bank), or CLOCK SUSPEND operation (burst/access in progress). CKE is synchronous except after the device enters power-down and self refresh modes, where CKE becomes asynchronous until after exiting the same mode. The input buffers, including CLK, are disabled during power-down and self refresh modes, providing low standby power. CKE may be tied HIGH.
G9	CS#	Input	Chip select: CS# enables (registered LOW) and disables (registered HIGH) the command decoder. All commands are masked when CS# is registered HIGH, but READ/WRITE bursts already in progress will continue and DQM will retain its DQ mask capability while CS# remains HIGH. CS# provides for external bank selection on systems with multiple banks. CS# is considered part of the command code.
F7, F8, F9	CAS#, RAS#, WE#	Input	Command inputs: CAS#, RAS#, and WE# (along with CS#) define the command being entered.
E8, F1	LDQM, UDQM	Input	Input/Output mask: DQM is sampled HIGH and is an input mask signal for write accesses and an output enable signal for read accesses. Input data is masked during a WRITE cycle. The output buffers are placed in a High-Z state (2-clock latency) during a READ cycle. LDQM corresponds to DQ0–DQ7, and UDQM corresponds to DQ8–DQ15. LDQM and UDQM are considered same state when referenced as DQM.
G7, G8	BA0, BA1	Input	Bank address input(s): BA0 and BA1 define to which bank the ACTIVE, READ, WRITE, or PRECHARGE command is being applied. These pins also provide the op-code during a LOAD MODE REGISTER command.
H7, H8, J8, J7, J3, J2, H3, H2, H1, G3, H9, G2	A0–A6 A7–A11	Input	Address inputs: A0–A11 are sampled during the ACTIVE command (row-address A0–A11) and READ/WRITE command (column-address A0–A8; with A10 defining auto precharge) to select one location out of the memory array in the respective bank. A10 is sampled during a PRECHARGE command to determine whether all banks are to be precharged (A10 HIGH) or bank selected by BA0, BA1 (LOW). The address inputs also provide the op-code during a LOAD MODE REGISTER command.
A8, B9, B8, C9, C8, D9, D8, E9, E1, D2, D1, C2, C1, B2, B1, A2	DQ0–DQ5 DQ6–DQ11 DQ12–DQ15	I/O	Data input/output: Data bus.
E2, G1	NC	–	No connect: These pins should be left unconnected. G1 is a no connect for this part but may be used as A12 in future designs.
A7, B3, C7, D3	VDDQ	Supply	DQ power: Isolated DQ power on the die to improve noise immunity.
A3, B7, C3, D7	VSSQ	Supply	DQ ground: Isolated DQ power on the die to improve noise immunity.
A9, E7, J9	VDD	Supply	Power supply: Voltage dependant on option.
A1, E3, J1	VDD	Supply	Ground.

Table 4: Ball Descriptions: 90-Ball VFBGA

90-Ball FBGA	Symbol	Type	Description
J1	CLK	Input	Clock: CLK is driven by the system clock. All SDRAM input signals are sampled on the positive edge of CLK. CLK also increments the internal burst counter and controls the output registers.
J2	CKE	Input	Clock enable: CKE activates (HIGH) and deactivates (LOW) the CLK signal. Deactivating the clock provides precharge power-down and SELF REFRESH operation (all banks idle), active power-down (row active in any bank), or CLOCK SUSPEND operation (burst/access in progress). CKE is synchronous except after the device enters power-down and self refresh modes, where CKE becomes asynchronous until after exiting the same mode. The input buffers, including CLK, are disabled during power-down and self refresh modes, providing low standby power. CKE may be tied HIGH.
J8	CS#	Input	Chip select: CS# enables (registered LOW) and disables (registered HIGH) the command decoder. All commands are masked when CS# is registered HIGH, but READ/WRITE bursts already in progress will continue and DQM will retain its DQ mask capability while CS# remains HIGH. CS# provides for external bank selection on systems with multiple banks. CS# is considered part of the command code.
J9, K7, K8	RAS#, CAS#, WE#	Input	Command inputs: RAS#, CAS#, and WE# (along with CS#) define the command being entered.
K9, K1, F8, F2	DQM0–3	Input	Input/Output mask: DQM is sampled HIGH and is an input mask signal for write accesses and an output enable signal for read accesses. Input data is masked during a WRITE cycle. The output buffers are placed in a High-Z state (2-clock latency) during a READ cycle. DQM0 corresponds to DQ0–DQ7, DQM1 corresponds to DQ8–DQ15, DQM2 corresponds to DQ16–DQ23, and DQM3 corresponds to DQ24–DQ31. DQM0–3 are considered same state when referenced as DQM.
J7, H8	BA0, BA1	Input	Bank address input(s): BA0 and BA1 define to which bank the ACTIVE, READ, WRITE, or PRECHARGE command is being applied. These pins also provide the op-code during a LOAD MODE REGISTER command.
G8, G9, F7, F3, G1, G2, G3, H1, H2, J3, G7, H9	A0–A5 A6–A11	Input	Address inputs: A0–A11 are sampled during the ACTIVE command (row-address A0–A11) and READ/WRITE command (column-address A0–A7; with A10 defining auto precharge) to select one location out of the memory array in the respective bank. A10 is sampled during a PRECHARGE command to determine whether all banks are to be precharged (A10 HIGH) or bank selected by BA0, BA1 (LOW). The address inputs also provide the op-code during a LOAD MODE REGISTER command.
R8, N7, R9, N8, P9, M8, M7, L8, L2, M3, M2, P1, N2, R1, N3, R2, E8, D7, D8, B9, C8, A9, C7, A8, A2, C3, A1, C2, B1, D2, D3, E2	DQ0–DQ5 DQ6–DQ11 DQ12–DQ17 DQ18–DQ23 DQ24–DQ29 DQ30–DQ31	I/O	Data input/output: Data bus.
E3, E7, H3, H7, K2, K3	NC	–	No connect: These pins should be left unconnected. H3 is a no connect for this part, but may be used as A12 in future designs.
B2, B7, C9, D9, E1, L1, M9, N9, P2, P7	VDDQ	Supply	DQ power: Isolated DQ power on the die to improve noise immunity.
B8, B3, C1, D1, E9, L9, M1, N1, P3, P8	VSSQ	Supply	DQ ground: Isolated DQ power on the die to improve noise immunity.
A7, F9, L7, R7	VDD	Supply	Power supply: Voltage dependant on option.
A3, F1, L3, R3	VSS	Supply	Ground.

Table 5: Pin Descriptions: 54-Pin TSOP (x16 Only)

54-Pin TSOP	Symbol	Type	Description
38	CLK	Input	Clock: CLK is driven by the system clock. All SDRAM input signals are sampled on the positive edge of CLK. CLK also increments the internal burst counter and controls the output registers.
37	CKE	Input	Clock enable: CKE activates (HIGH) and deactivates (LOW) the CLK signal. Deactivating the clock provides precharge power-down and SELF REFRESH operation (all banks idle), active power-down (row active in any bank), or CLOCK SUSPEND operation (burst/access in progress). CKE is synchronous except after the device enters power-down and self refresh modes, where CKE becomes asynchronous until after exiting the same mode. The input buffers, including CLK, are disabled during power-down and self refresh modes, providing low standby power. CKE may be tied HIGH.
19	CS#	Input	Chip select: CS# enables (registered LOW) and disables (registered HIGH) the command decoder. All commands are masked when CS# is registered HIGH, but READ/WRITE bursts already in progress will continue and DQM will retain its DQ mask capability while CS# remains HIGH. CS# provides for external bank selection on systems with multiple banks. CS# is considered part of the command code.
16, 17, 18	WE#, CAS#, RAS#	Input	Command inputs: WE#, CAS#, and RAS# (along with CS#) define the command being entered.
15, 39	DQML, DQMH	Input	Input/Output mask: DQM is sampled HIGH and is an input mask signal for write accesses and an output enable signal for read accesses. Input data is masked during a WRITE cycle. The output buffers are placed in a High-Z state (2-clock latency) during a READ cycle. DQM0 corresponds to DQ0–DQ7, DQM1 corresponds to DQ8–DQ15, DQM2 corresponds to DQ16–DQ23, and DQM3 corresponds to DQ24–DQ31. LDQM corresponds to DQ0–DQ7, and UDQM corresponds to DQ8–DQ15. LDQM and UDQM are considered same state when referenced as DQM.
20, 21	BA0, BA1	Input	Bank address input(s): BA0 and BA1 define to which bank the ACTIVE, READ, WRITE, or PRECHARGE command is being applied. These pins also provide the op-code during a LOAD MODE REGISTER command.
23, 24, 25, 29, 30, 31, 32, 33, 34, 22, 35	A0–A5 A6–A11	Input	Address inputs: A0–A11 are sampled during the ACTIVE command (row-address A0–A11) and READ/WRITE command (column-address A0–A7; with A10 defining auto precharge) to select one location out of the memory array in the respective bank. A10 is sampled during a PRECHARGE command to determine whether all banks are to be precharged (A10 HIGH) or bank selected by BA0, BA1 (LOW). The address inputs also provide the op-code during a LOAD MODE REGISTER command.
2, 4, 5, 7, 8, 10, 11, 13, 42, 49, 45, 47, 48, 50, 51	DQ0–DQ7 DQ8–DQ15	I/O	Data input/output: Data bus (x16 only).
36, 40	NC	–	No connect: These pins should be left unconnected. Pin 36 is a no connect for this part, but may be used as A12 in future designs.
3, 9, 43, 49	VDDQ	Supply	DQ power: Isolated DQ power on the die to improve noise immunity.
6, 12, 46, 52	VSSQ	Supply	DQ ground: Isolated DQ power on the die to improve noise immunity.
1, 14, 27	VDD	Supply	Power supply: Voltage dependant on option.
28, 41, 54	VSS	Supply	Ground.

Functional Description

In general, the 128Mb SDRAMs (2 Meg x 16 x 4 banks and 1 Meg x 32 x 4 banks) are quad-bank DRAMs that operate at 3.3V or 2.5V and include a synchronous interface (all signals are registered on the positive edge of the clock signal, CLK). Each of the x16's 33,554,432-bit banks is organized as 4,096 rows by 512 columns by 16 bits. Each of the x32's 33,554,432-bit banks is organized as 4,096 rows by 256 columns by 32 bits.

Read and write accesses to the SDRAM are burst oriented; accesses start at a selected location and continue for a programmed number of locations in a programmed sequence. Accesses begin with the registration of an ACTIVE command, which is then followed by a READ or WRITE command. The address bits registered coincident with the ACTIVE command are used to select the bank and row to be accessed (BA0 and BA1 select the bank, A0–A11 select the row). The address bits (x16: A0–A8; x32: A0–A7) registered coincident with the READ or WRITE command are used to select the starting column location for the burst access.

Prior to normal operation, the SDRAM must be initialized. The following sections provide detailed information covering device initialization, register definition, command descriptions, and device operation.

Initialization

SDRAMs must be powered up and initialized in a predefined manner. Operational procedures other than those specified may result in undefined operation. After power is applied to VDD and VDDQ (simultaneously) and the clock is stable (stable clock is defined as a signal cycling within timing constraints specified for the clock pin), the SDRAM requires a 100 μ s delay prior to issuing any command other than a COMMAND INHIBIT or NOP. Starting at some point during this 100 μ s period and continuing at least through the end of this period, COMMAND INHIBIT or NOP commands must be applied.

After the 100 μ s delay has been satisfied with at least one COMMAND INHIBIT or NOP command having been applied, a PRECHARGE command should be applied. All banks must then be precharged, thereby placing the device in the all banks idle state.

Once in the idle state, at least two AUTO REFRESH cycles must be performed. After the AUTO REFRESH cycles are complete, the SDRAM is ready for mode register programming. Because the mode register will power up in an unknown state, it must be loaded prior to applying any operational command. If desired, the two AUTO REFRESH commands can be issued after the LOAD MODE REGISTER (LMR) command.

The recommended power-up sequence for SDRAMs:

1. Simultaneously apply power to VDD and VDDQ.
2. Assert and hold CKE at a LVTTTL logic LOW.
3. Provide stable CLOCK signal. Stable clock is defined as a signal cycling within timing constraints specified for the clock pin.
4. Wait at least 100 μ s prior to issuing any command other than a COMMAND INHIBIT or NOP.
5. Starting at some point during this 100 μ s period, bring CKE HIGH. Continuing at least through the end of this period, one or more COMMAND INHIBIT or NOP commands must be applied.
6. Perform a PRECHARGE ALL command.

7. Wait at least t_{RP} time; during this time, NOPs or DESELECT commands must be given. All banks will complete their precharge, thereby placing the device in the all banks idle state.
8. Issue an AUTO REFRESH command.
9. Wait at least t_{RFC} time, during which only NOPs or COMMAND INHIBIT commands are allowed.
10. Issue an AUTO REFRESH command.
11. Wait at least t_{RFC} time, during which only NOPs or COMMAND INHIBIT commands are allowed.
12. The SDRAM is now ready for mode register programming. Because the mode register will power up in an unknown state, it should be loaded with desired bit values prior to applying any operational command. Using the LMR command, program the mode register. The mode register is programmed via the MODE REGISTER SET command with BA1 = 0, BA0 = 0 and retains the stored information until it is programmed again or the device loses power. Not programming the mode register upon initialization will result in default settings, which may not be desired. Outputs are guaranteed High-Z after the LMR command is issued. Outputs should be High-Z already before the LMR command is issued.
13. Wait at least t_{MRD} time, during which only NOP or DESELECT commands are allowed.
14. Using the LMR command, program the extended mode register. The low-power extended mode register is programmed via the MODE REGISTER SET command with BA1 = 1, BA0 = 0 and retains the stored information until it is programmed again or the device loses power. Not programming the extended mode register upon initialization will result in default settings for the low-power features. The extended mode will default with the temperature sensor enabled, full drive strength, and full array refresh.
15. Wait at least t_{MRD} time, during which only NOP or DESELECT commands are allowed.

At this point, the DRAM is ready for any valid command.

Note: If desired, more than two AUTO REFRESH commands can be issued in the sequence. After steps 9 and 10 are complete, repeat them until the desired number of AUTO REFRESH + t_{RFC} loops is achieved.

Register Definition

Mode Register

To achieve low power consumption, there are two mode registers in the Mobile component: mode register and extended mode register. Mode register is discussed in this section. Extended mode register is discussed on page 21. The mode register is used to define the specific mode of operation of the SDRAM. This definition includes the selection of BL, a burst type, CL, an operating mode, and a write burst mode, as shown in Figure 7 on page 18. The mode register is programmed via the LOAD MODE REGISTER command and will retain the stored information until it is programmed again or the device loses power.

Mode register bits M0–M2 specify BL, M3 specifies the type of burst (sequential or interleaved), M4–M6 specify CL, M7 and M8 specify the operating mode, M9 specify the write burst mode (single or programmed burst length), M10 and M11 are reserved and must be set to zero. To address the mode register, M12 and M13 must be set to zero.

The mode register must be loaded when all banks are idle, and the controller must wait the specified time before initiating the subsequent operation. Violating either of these requirements will result in unspecified operation.

Burst Length (BL)

Read and write accesses to the SDRAM are burst oriented, with BL being programmable, as shown in Figure 8 on page 20. BL determines the maximum number of column locations that can be accessed for a given READ or WRITE command. Burst lengths of 1, 2, 4, or 8 locations are available for both the sequential and the interleaved burst types, and a full-page burst is available for the sequential mode. The full-page burst is used in conjunction with the BURST TERMINATE command to generate arbitrary burst lengths. If a full page burst is not terminated at the end of the page, it could wrap to column zero and continue.

Reserved states cannot be used because unknown operation or incompatibility with future versions may result.

When a READ or WRITE command is issued, a block of columns equal to BL is effectively selected. All accesses for that burst take place within this block, meaning that the burst will wrap within the block if a boundary is reached. The block is uniquely selected by A1–A8 (x16) or A1–A7 (x32) when BL = 2; by A2–A8 (x16) or A2–A7 (x32) when BL = 4; and by A3–A8 (x16) or A3–A7 (x32) when BL = 8. The remaining (least significant) address bit(s) is (are) used to select the starting location within the block. Full-page bursts wrap within the page if the boundary is reached.

Burst Type

Accesses within a given burst may be programmed either to be sequential or interleaved; this is referred to as the burst type and is selected via bit M3. Note only a sequential burst is allowed for full page bursts.

The ordering of accesses within a burst is determined by BL, the burst type, and the starting column address, as shown in Table 6 on page 19.

Figure 7: Mode Register Definition

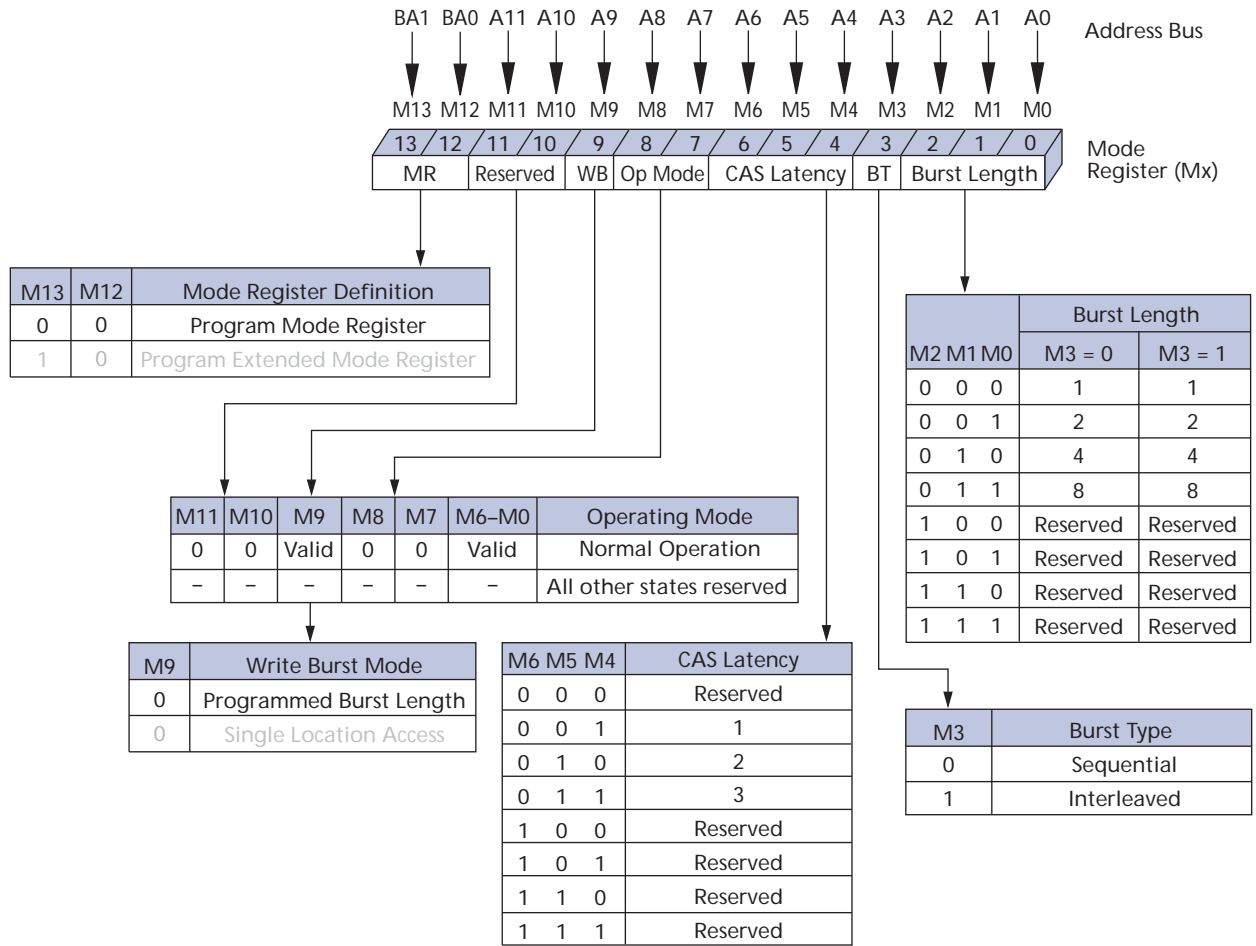

Table 6: Burst Definition

Burst Length	Starting Column Address			Order of Accesses Within a Burst	
				Type = Sequential	Type = Interleaved
2			A0		
			0	0-1	0-1
			1	1-0	1-0
4		A1	A0		
		0	0	0-1-2-3	0-1-2-3
		0	1	1-2-3-0	1-0-3-2
		1	0	2-3-0-1	2-3-0-1
		1	1	3-0-1-2	3-2-1-0
8	A2	A1	A0		
	0	0	0	0-1-2-3-4-5-6-7	0-1-2-3-4-5-6-7
	0	0	1	1-2-3-4-5-6-7-0	1-0-3-2-5-4-7-6
	0	1	0	2-3-4-5-6-7-0-1	2-3-0-1-6-7-4-5
	0	1	1	3-4-5-6-7-0-1-2	3-2-1-0-7-6-5-4
	1	0	0	4-5-6-7-0-1-2-3	4-5-6-7-0-1-2-3
	1	0	1	5-6-7-0-1-2-3-4	5-4-7-6-1-0-3-2
	1	1	0	6-7-0-1-2-3-4-5	6-7-4-5-2-3-0-1
	1	1	1	7-0-1-2-3-4-5-6	7-6-5-4-3-2-1-0
Full page (y)	n = A0–A8 for x16, A0–A7 for x32 (location 0–y)			Cn, Cn + 1, Cn + 2, Cn + 3, Cn + 4..., ...Cn - 1, Cn...	Not supported

NOTE:

- Notes:
- For full-page accesses: y = 512 (x16), y = 256 (x32).
 - For BL = 2, A1–A8 (x16) or A1–A7 (x32) select the block-of-two burst; A0 selects the starting column within the block.
 - For BL = 4, A2–A8 (x16) or A2–A7 (x32) select the block-of-four burst; A0–A1 select the starting column within the block.
 - For BL = 8, A3–A8 (x16) or A3–A7 (x32) select the block-of-eight burst; A0–A2 select the starting column within the block.
 - For a full-page burst, the full row is selected, and A0–A8 (x16) or A0–A7 (x32) select the starting column.
 - Whenever a boundary of the block is reached within a given sequence above, the following access wraps within the block.
 - For BL = 1, A0–A8 (x16) or A0–A7 (x32) select the unique column to be accessed, and mode register bit M3 is ignored.

CAS Latency (CL)

CL is the delay, in clock cycles, between the registration of a READ command and the availability of the first piece of output data. The latency can be set to 1, 2, or 3 clocks.

If a READ command is registered at clock edge n and the latency is m clocks, the data will be available by clock edge $n + m$. The DQ will start driving as a result of the clock edge one cycle earlier ($n + m - 1$), and provided that the relevant access times are met, the data will be valid by clock edge $n + m$. For example, assuming that the clock cycle time is such that all relevant access times are met, if a read command is registered at T0 and the

latency is programmed to 2 clocks, the DQ will start driving after T1, and the data will be valid by T2, as shown in Figure 8. Table 7 indicates the operating frequencies at which each CL setting can be used.

Reserved states should not be used as unknown operation or incompatibility with future versions may result.

Figure 8: CAS Latency

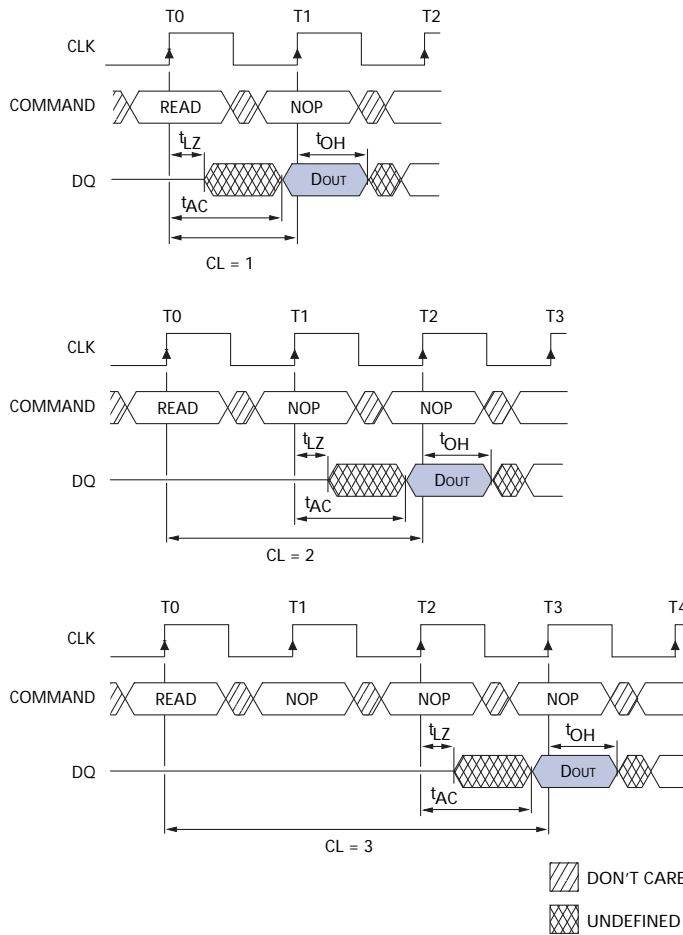

Table 7: CAS Latency

Speed	Allowable Operating Frequency (MHz)		
	CL = 1	CL = 2	CL = 3
-75M	-	≤ 100	≤ 133
-8	≤ 50	≤ 100	≤ 125
-10	≤ 40	≤ 83	≤ 100

Write Burst Mode

When M9 = 0, BL programmed into M0–M2 applies to both READ and WRITE burst. If M9 = 1, all WRITE bursts will only be single location access regardless of the BL setting in the mode register. READ burst lengths are unaffected by the state of M9.

Operating Mode

The normal operating mode is selected by setting M7, M8, M10, and M11 to zero; all the other combinations of values for M7, M8, M10, and M11 are reserved for future use and/or test modes.

Test modes and reserved states should not be used because unknown operation or incompatibility with future versions may result.

Extended Mode Register

The extended mode register controls the functions beyond those controlled by the mode register. These additional functions are special features of the Mobile device. They include TCSR and PASR.

Figure 9: Extended Mode Register

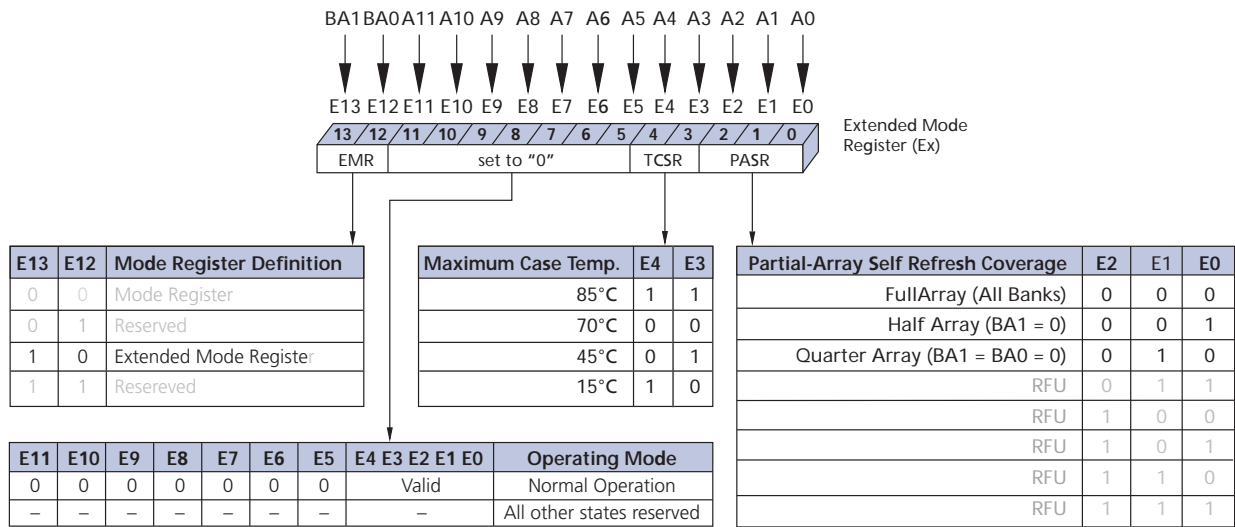

- Notes:
1. E13 and E12 (BA1 and BA0) must be "1, 0" to select the extended mode register (vs. the base mode register).
 2. RFU: reserved for future use.

The extended mode register is programmed via the MODE REGISTER SET command (BA1 = 1, BA0 = 0) and retains the stored information until it is programmed again or the device loses power.

The extended mode register must be programmed with E5 through E11 set to "0." The extended mode register must be loaded when all banks are idle and no bursts are in progress, and the controller must wait the specified time before initiating any subsequent operation. Violating either of these requirements results in unspecified operation. The extended mode register must be programmed to ensure proper operation.

Temperature-Compensated Self Refresh (TCSR)

TCSR allows the controller to program the refresh interval during self refresh mode, according to the case temperature of the Mobile device. This allows great power savings during self refresh during most operating temperature ranges. Only during extreme temperatures would the controller have to select a higher TCSR level that will guarantee data during self refresh.

Every cell in the DRAM requires refreshing due to the capacitor losing its charge over time. The refresh rate is dependent on temperature. At higher temperatures a capacitor loses charge quicker than at lower temperatures, requiring the cells to be refreshed more often. Historically, during self refresh, the refresh rate has been set to accommodate the worst case, or highest temperature range, expected.

Thus, during ambient temperatures, the power consumed during refresh was unnecessarily high because the refresh rate was set to accommodate the higher temperatures. Setting E4 and E3 allows the DRAM to accommodate more specific temperature regions during self refresh. There are four temperature settings, which will vary the self refresh current according to the selected temperature. This selectable refresh rate will save power when the DRAM is operating at normal temperatures.

Partial-Array Self Refresh (PASR)

For further power savings during self refresh, the PASR feature allows the controller to select the amount of memory that will be refreshed during self refresh. The refresh options are all banks (banks 0, 1, 2, and 3); two banks (banks 0 and 1); and one bank (bank 0). WRITE and READ commands occur to any bank selected during standard operation, but only the selected banks in PASR will be refreshed during self refresh. It's important to note that data in banks 2 and 3 will be lost when the two-bank option is used. Data will be lost in banks 1, 2, and 3 when the one-bank option is used.

Commands

Table 8 provides a quick reference of available commands. This is followed by a written description of each command. Three additional Truth Tables appear following the Operation section; these tables provide current state/next state information.

Table 8: Truth Table – Commands and DQM Operation

Note 1 applies to entire table

Name (Function)	CS#	RAS#	CAS#	WE#	DQM	Addr	DQ	Notes
COMMAND INHIBIT (NOP)	H	X	X	X	X	X	X	
NO OPERATION (NOP)	L	H	H	H	X	X	X	
ACTIVE (Select bank and activate row)	L	L	H	H	X	Bank/row	X	2
READ (Select bank and column, and start READ burst)	L	H	L	H	L/H ⁸	Bank/col	X	3
WRITE (Select bank and column, and start WRITE burst)	L	H	L	L	L/H ⁸	Bank/col	Valid	3
BURST TERMINATE	L	H	H	L	X	X	Active	
PRECHARGE (Deactivate row in bank or banks)	L	L	H	L	X	Code	X	4
AUTO REFRESH or SELF REFRESH (Enter self refresh mode)	L	L	L	H	X	X	X	5, 6
LOAD MODE REGISTER	L	L	L	L	X	Op-code	X	7
Write enable/output enable	–	–	–	–	L	–	Active	8
Write inhibit/output High-Z	–	–	–	–	H	–	High-Z	8

- Notes:
1. CKE is HIGH for all commands shown except SELF REFRESH.
 2. A0–A11 provide row address, and BA0, BA1 determine which bank is made active.
 3. A0–A8 (x16) or A0–A7 (x32) provide column address; A10 HIGH enables the auto precharge feature (nonpersistent), while A10 LOW disables the auto precharge feature; BA0, BA1 determine which bank is being read from or written to.
 4. A10 LOW: BA0, BA1 determine the bank being precharged. A10 HIGH: All banks precharged and BA0, BA1 are “Don’t Care.”
 5. This command is AUTO REFRESH if CKE is HIGH, SELF REFRESH if CKE is LOW.
 6. Internal refresh counter controls row addressing; all inputs and I/Os are “Don’t Care” except for CKE.
 7. A0–A10 define the op-code written to the mode register. BA0–BA1 either select mode register or the extended mode register (BA0 = BA1 = 0 select the mode register, BA1 = 1, BA0 = 0 selects the extended mode register, all other combinations of BA0–BA1 are reserved).
 8. Activates or deactivates the DQ during WRITES (0-clock delay) and READS (2-clock delay). For x16, LDQM controls DQ0–DQ7, and UDQM controls DQ8–DQ15. For x32, DQM0 controls DQ0–DQ7, DQM1 controls DQ8–DQ15, DQM2 controls DQ16–23, and DQM3 controls DQ24–DQ31.

COMMAND INHIBIT

The COMMAND INHIBIT function prevents new commands from being executed by the SDRAM, regardless of whether the CLK signal is enabled. The SDRAM is effectively deselected. Operations already in progress are not affected.

NO OPERATION (NOP)

The NO OPERATION (NOP) command is used to instruct the selected SDRAM to perform a NOP (RAS#, CAS#, and WE# are HIGH, and CS# is LOW). This prevents unwanted commands from being registered during idle or wait states. Operations already in progress are not affected.

LOAD MODE REGISTER

The mode register is loaded via inputs A0–A11. Refer to “Mode Register Definition” on page 18. The LOAD MODE REGISTER and LOAD EXTENDED MODE REGISTER commands can only be issued when all banks are idle, and a subsequent executable command cannot be issued until t_{MRD} is met.

ACTIVE

The ACTIVE command is used to open (or activate) a row in a particular bank for a subsequent access. The value on the BA0, BA1 inputs selects the bank, and the address provided on inputs A0–A11 selects the row. This row remains active (or open) for accesses until a PRECHARGE command is issued to that bank. A PRECHARGE command must be issued before opening a different row in the same bank.

READ

The READ command is used to initiate a burst read access to an active row. The value on the BA0, BA1 inputs selects the bank, and the address provided on inputs A0–A8 (x16) or A0–A7 (x32) selects the starting column location. The value on input A10 determines whether auto precharge is used. If auto precharge is selected, the row being accessed will be precharged at the end of the read burst; if auto precharge is not selected, the row will remain open for subsequent accesses. Read data appears on the DQ subject to the logic level on the DQM inputs two clocks earlier. If a given DQM signal was registered HIGH, the corresponding DQ will be High-Z two clocks later; if the DQM signal was registered LOW, the DQ will provide valid data.

WRITE

The WRITE command is used to initiate a burst write access to an active row. The value on the BA0, BA1 inputs selects the bank, and the address provided on inputs A0–A8 (x16) or A0–A7 (x32) selects the starting column location. The value on input A10 determines whether auto precharge is used. If auto precharge is selected, the row being accessed will be precharged at the end of the write burst; if auto precharge is not selected, the row will remain open for subsequent accesses. Input data appearing on the DQ is written to the memory array subject to the DQM input logic level appearing coincident with the data. If a given DQM signal is registered LOW, the corresponding data will be written to memory; if the DQM signal is registered HIGH, the corresponding data inputs will be ignored, and a write will not be executed to that byte/column location.

PRECHARGE

The PRECHARGE command is used to deactivate the open row in a particular bank or the open row in all banks. The bank(s) will be available for a subsequent row access a specified time (t_{RP}) after the PRECHARGE command is issued. Input A10 determines whether one or all banks are to be precharged, and in the case where only one bank is to be precharged, inputs BA0, BA1 select the bank. Otherwise BA0, BA1 are treated as “Don’t Care.” After a bank has been precharged, it is in the idle state and must be activated prior to any READ or WRITE commands being issued to that bank.

Auto Precharge

Auto precharge is a feature that performs the same individual-bank precharge function described above, without requiring an explicit command. This is accomplished by using A10 to enable auto precharge in conjunction with a specific READ or WRITE command. A precharge of the bank/row that is addressed with the READ or WRITE command is

automatically performed upon completion of the READ or WRITE burst, except in the full-page burst mode where auto precharge does not apply. Auto precharge is nonpersistent in that it is either enabled or disabled for each individual read or write command.

Auto precharge ensures that the precharge is initiated at the earliest valid stage within a burst. The user must not issue another command to the same bank until the precharge time (t_{RP}) is completed. This is determined as if an explicit PRECHARGE command was issued at the earliest possible time, as described for each burst type in “Operation” on page 26.

BURST TERMINATE

The BURST TERMINATE command is used to truncate either fixed-length or full-page bursts. The most recently registered READ or WRITE command prior to the BURST TERMINATE command will be truncated, as shown in the Operation section of this data sheet. The BURST TERMINATE command does not precharge the row; the row will remain open until a PRECHARGE command is issued.

AUTO REFRESH

AUTO REFRESH is used during normal operation of the SDRAM and is analogous to CAS#-BEFORE-RAS# (CBR) refresh in conventional DRAMs. This command is nonpersistent, so it must be issued each time a refresh is required. All active banks must be PRECHARGED prior to issuing an AUTO REFRESH command. The AUTO REFRESH command should not be issued until the minimum t_{RP} has been met after the PRECHARGE command as shown in the operation section.

The addressing is generated by the internal refresh controller. This makes the address bits “Don’t Care” during an AUTO REFRESH command. Regardless of device width, the 128Mb SDRAM requires 4,096 AUTO REFRESH cycles every 64ms (commercial and industrial) or 16ms (automotive). Providing a distributed AUTO REFRESH command every 15.625 μ s (commercial and industrial) or 3.906 μ s (automotive) will meet the refresh requirement and ensure that each row is refreshed. Alternatively, 4,096 AUTO REFRESH commands can be issued in a burst at the minimum cycle rate (t_{RFC}), once every 64ms (commercial and industrial) or 16ms (automotive).

SELF REFRESH

The SELF REFRESH command can be used to retain data in the SDRAM, even if the rest of the system is powered down. When in the self refresh mode, the SDRAM retains data without external clocking. The SELF REFRESH command is initiated like an AUTO REFRESH command except CKE is disabled (LOW). After the SELF REFRESH command is registered, all the inputs to the SDRAM become “Don’t Care” with the exception of CKE, which must remain LOW.

After self refresh mode is engaged, the SDRAM provides its own internal clocking, causing it to perform its own auto refresh cycles. The SDRAM must remain in self refresh mode for a minimum period equal to t_{RAS} and may remain in self refresh mode for an indefinite period beyond that.

The procedure for exiting self refresh requires a sequence of commands. First, CLK must be stable (stable clock is defined as a signal cycling within timing constraints specified for the clock pin) prior to CKE going back HIGH. After CKE is HIGH, the SDRAM must have NOP commands issued (a minimum of 2 clocks, regardless of clock frequency) for t_{XSR} because time is required for the completion of any internal refresh in progress.

Upon exiting the self refresh mode, AUTO REFRESH commands must be issued every 15.625µs or less because both SELF REFRESH and AUTO REFRESH utilize the row refresh counter.

Self refresh is not supported on automotive temperature (AT) devices.

Operation

BANK/ROW ACTIVATION

Before any READ or WRITE commands can be issued to a bank within the SDRAM, a row in that bank must be “opened.” This is accomplished via the ACTIVE command, which selects both the bank and the row to be activated (see Figure 10).

After opening a row (issuing an ACTIVE command), a READ or WRITE command may be issued to that row, subject to the t_{RCD} specification. $t_{RCD} (MIN)$ should be divided by the clock period and rounded up to the next whole number to determine the earliest clock edge after the ACTIVE command on which a READ or WRITE command can be entered. For example, a t_{RCD} specification of 20ns with a 125 MHz clock (8ns period) results in 2.5 clocks, rounded to 3. This is reflected in Figure 11 on page 27, which covers any case where $2 < t_{RCD} (MIN)/t_{CK} \leq 3$. (The same procedure is used to convert other specification limits from time units to clock cycles.)

A subsequent ACTIVE command to a different row in the same bank can only be issued after the previous active row has been “closed” (precharged). The minimum time interval between successive ACTIVE commands to the same bank is defined by t_{RC} .

A subsequent ACTIVE command to another bank can be issued while the first bank is being accessed, which results in a reduction of total row-access overhead. The minimum time interval between successive ACTIVE commands to different banks is defined by t_{RRD} .

Figure 10: Activating a Specific Row in a Specific Bank

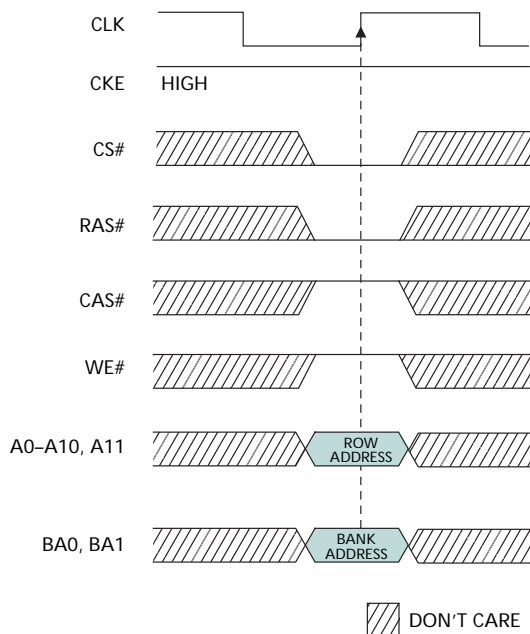
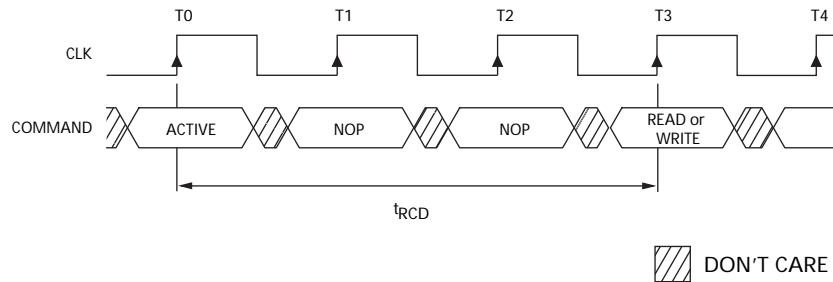

Figure 11: Example: Meeting $t_{RCD} (MIN)$ When $2 < t_{RCD} (MIN)/t_{CK} \leq 3$



READs

READ bursts are initiated with a READ command, as shown in Figure 12.

The starting column and bank addresses are provided with the READ command, and auto precharge is either enabled or disabled for that burst access. If auto precharge is enabled, the row being accessed is precharged at the completion of the burst. For the READ commands used in the following illustrations, auto precharge is disabled.

During READ bursts, the valid data-out element from the starting column address will be available following CL after the READ command. Each subsequent data-out element will be valid by the next positive clock edge. Figure 13 on page 28 shows general timing for each possible CL setting.

Figure 12: READ Command

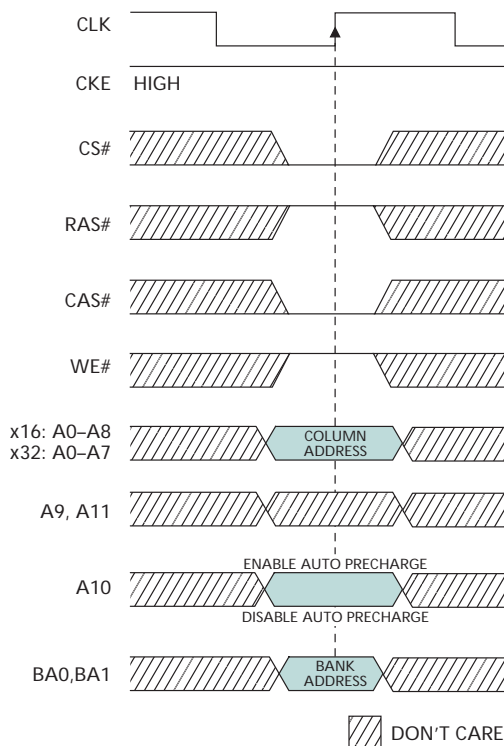

Upon completion of a burst, assuming no other commands have been initiated, the DQ will go High-Z. A full-page burst will continue until terminated. (At the end of the page, it will wrap to column 0 and continue.)

Data from any READ burst may be truncated with a subsequent READ command, and data from a fixed-length READ burst may be immediately followed by data from a READ command. In either case, a continuous flow of data can be maintained. The first data element from the new burst either follows the last element of a completed burst or the last desired data element of a longer burst that is being truncated. The new READ command should be issued x cycles before the clock edge at which the last desired data element is valid, where $x = CL - 1$.

Figure 13: CAS Latency

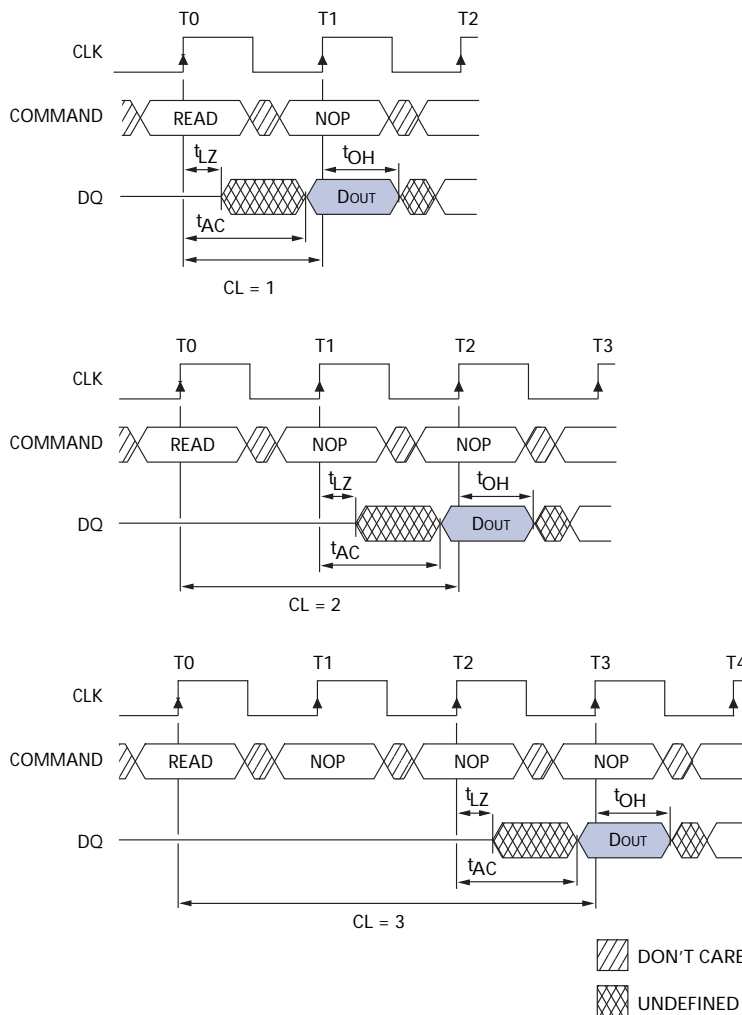

This is shown in Figure 14 on page 29 for CL = 2 and CL = 3; data element $n + 3$ is either the last of a burst of four or the last desired of a longer burst. The 128Mb SDRAM uses a pipelined architecture and, therefore, does not require the $2n$ rule associated with a prefetch architecture. A READ command can be initiated on any clock cycle following a previous READ command. Full-speed random read accesses can be performed to the same bank, as shown in Figure 15 on page 30, or each subsequent READ may be performed to a different bank.

Figure 14: Consecutive READ Bursts

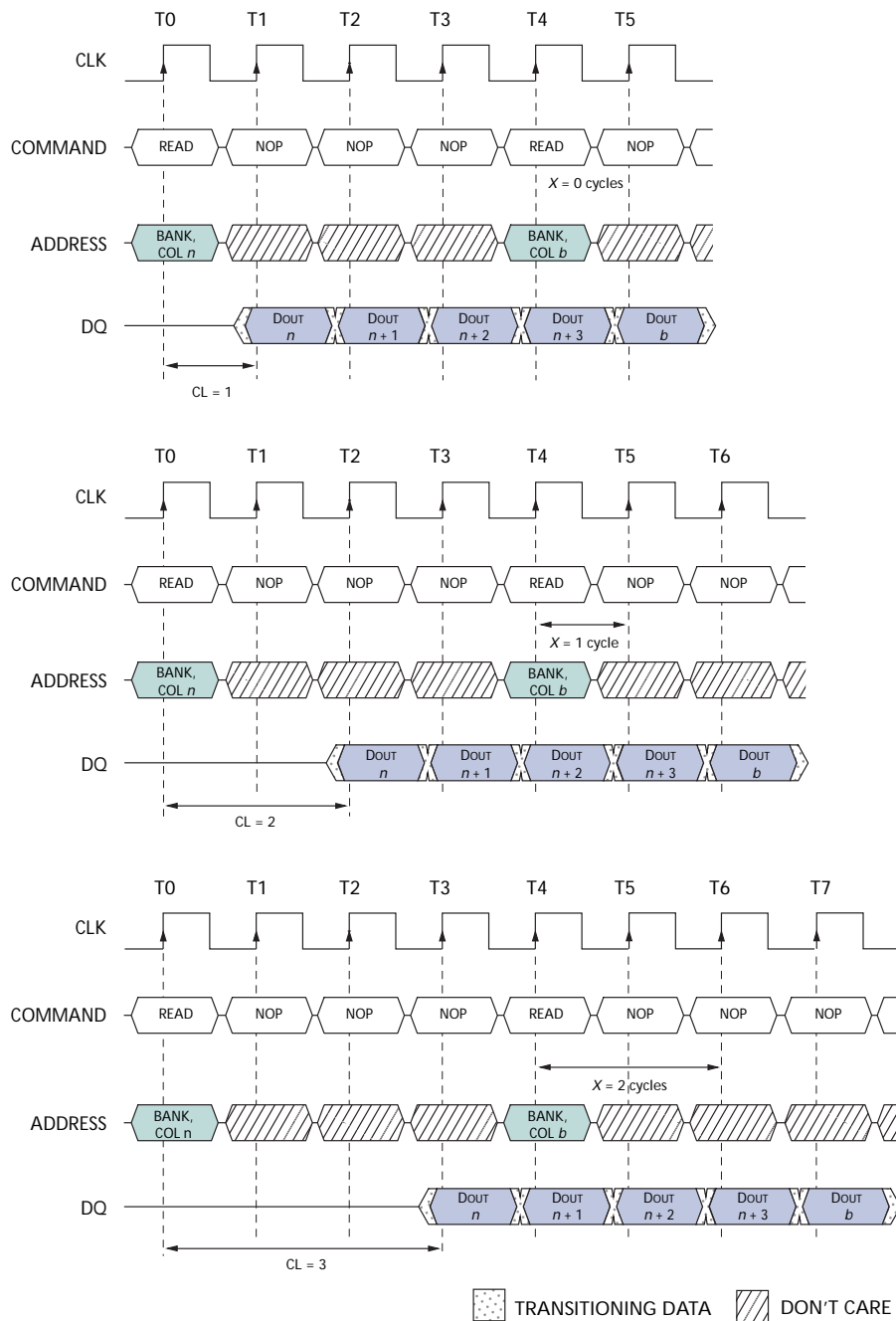

Notes: 1. Each READ command may be to either bank. DQM is LOW. Shown with BL = 4.

Figure 15: Random READ Accesses

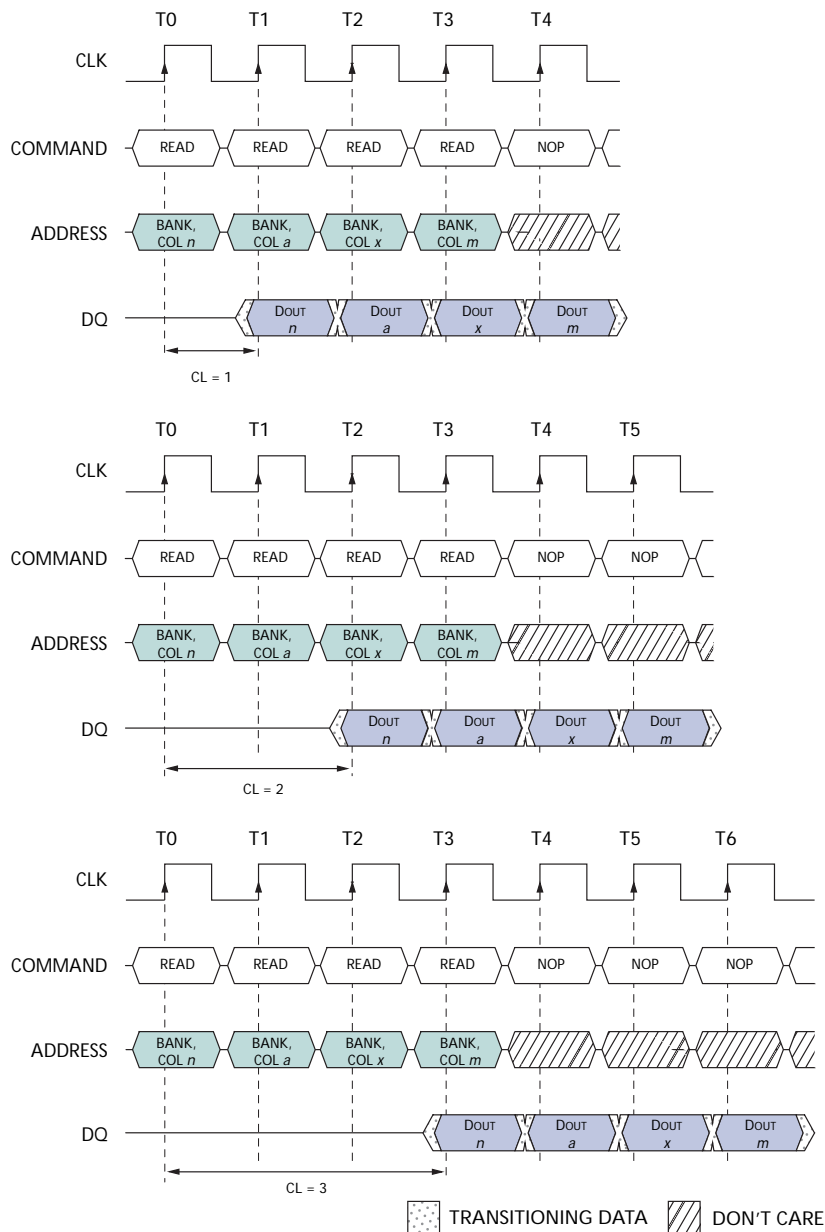

- Notes:
1. Each READ command may be to either bank. DQM is LOW.
 2. BL = 1, 2, 4, 8, or full page (if BL > 1, the following READ interrupts the previous).

Data from any READ burst may be truncated with a subsequent WRITE command, and data from a fixed-length READ burst may be immediately followed by data from a WRITE command (subject to bus turnaround limitations). The WRITE burst may be initiated on the clock edge immediately following the last (or last desired) data element from the READ burst, provided that I/O contention can be avoided. In a given system design, there may be a possibility that the device driving the input data will go Low-Z before the SDRAM DQ go High-Z. In this case, at least a single-cycle delay should occur between the last read data and the WRITE command.

Figure 16: READ-to-WRITE

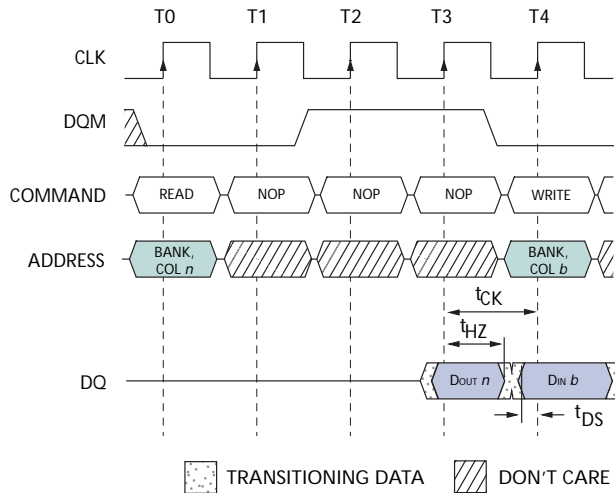

- Notes:
1. CL = 3 is used for illustration.
 2. The READ command may be to any bank, and the WRITE command may be to any bank.
 3. If a burst of 1 is used, then DQM is not required.

The DQM input is used to avoid I/O contention, as shown in Figure 16 and Figure 17. The DQM signal must be asserted (HIGH) at least 2 clocks prior to the WRITE command (DQM latency is 2 clocks for output buffers) to suppress data-out from the READ. After the WRITE command is registered, the DQ will go High-Z (or remain High-Z), regardless of the state of the DQM signal, provided the DQM was active on the clock just prior to the WRITE command that truncated the READ command. If not, the second WRITE will be an invalid WRITE. For example, if DQM was LOW during T4 in Figure 17, then the WRITES at T5 and T7 would be valid, while the WRITE at T6 would be invalid.

The DQM signal must be de-asserted prior to the WRITE command (DQM latency is 0 clocks for input buffers) to ensure that the written data is not masked. Figure 16 shows the case where the clock frequency allows for bus contention to be avoided without adding a NOP cycle, and Figure 17 shows the case where the additional NOP is needed.

Figure 17: READ-to-WRITE with Extra Clock Cycle

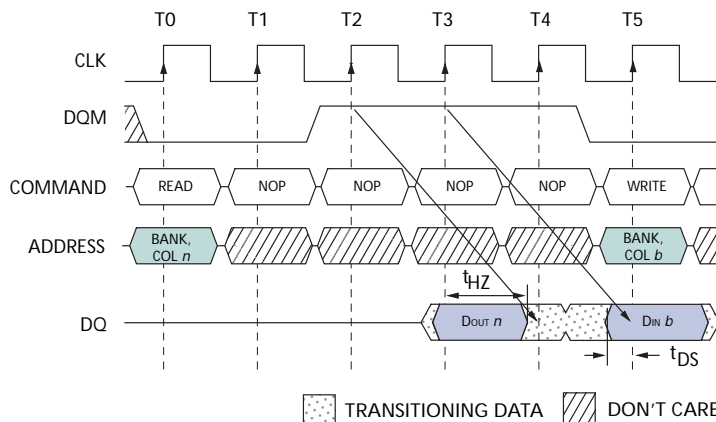

- Notes:
1. CL = 3 is used for illustration. The READ command may be to any bank, and the WRITE command may be to any bank.

A fixed-length READ burst may be followed by, or truncated with, a PRECHARGE command to the same bank (provided that auto precharge was not activated), and a full-page burst may be truncated with a PRECHARGE command to the same bank. The PRECHARGE command should be issued x cycles before the clock edge at which the last desired data element is valid, where $x = CL - 1$. This is shown in Figure 18 on page 33 for each possible CL; data element $n + 3$ is either the last of a burst of four or the last desired of a longer burst. Following the PRECHARGE command, a subsequent command to the same bank cannot be issued until t_{RP} is met. Note that part of the row precharge time is hidden during the access of the last data element(s).

In the case of a fixed-length burst being executed to completion, a PRECHARGE command issued at the optimum time (as described above) provides the same operation that would result from the same fixed-length burst with auto precharge. The disadvantage of the PRECHARGE command is that it requires that the command and address buses be available at the appropriate time to issue the command; the advantage of the PRECHARGE command is that it can be used to truncate fixed-length or full-page bursts.

Figure 18: READ-to-PRECHARGE

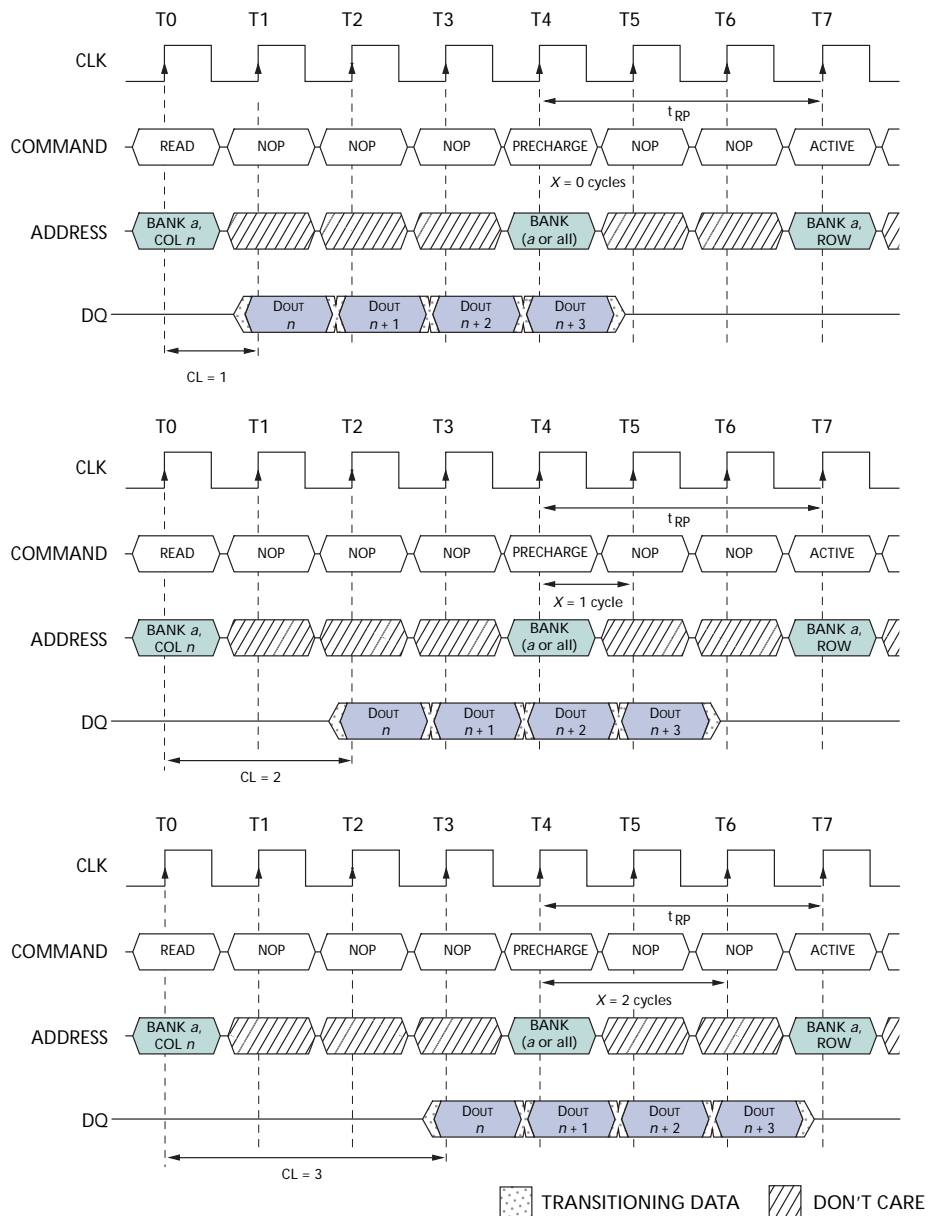

- Notes:
1. Assumes $t_{RAS(MIN)}$ has been satisfied prior to the PRECHARGE command.
 2. N + 3 is either the last data element of a BL = 4 or the last desired data element of a longer burst.
 3. DQM is LOW.

Full-page READ bursts can be truncated with the BURST TERMINATE command, and fixed-length READ bursts may be truncated with a BURST TERMINATE command, provided that auto precharge was not activated. The BURST TERMINATE command should be issued x cycles before the clock edge at which the last desired data element is valid, where $x = CL - 1$. This is shown in Figure 19 on page 34 for each possible CL; data element n + 3 is the last desired data element of a longer burst.

Figure 19: Terminating a READ Burst

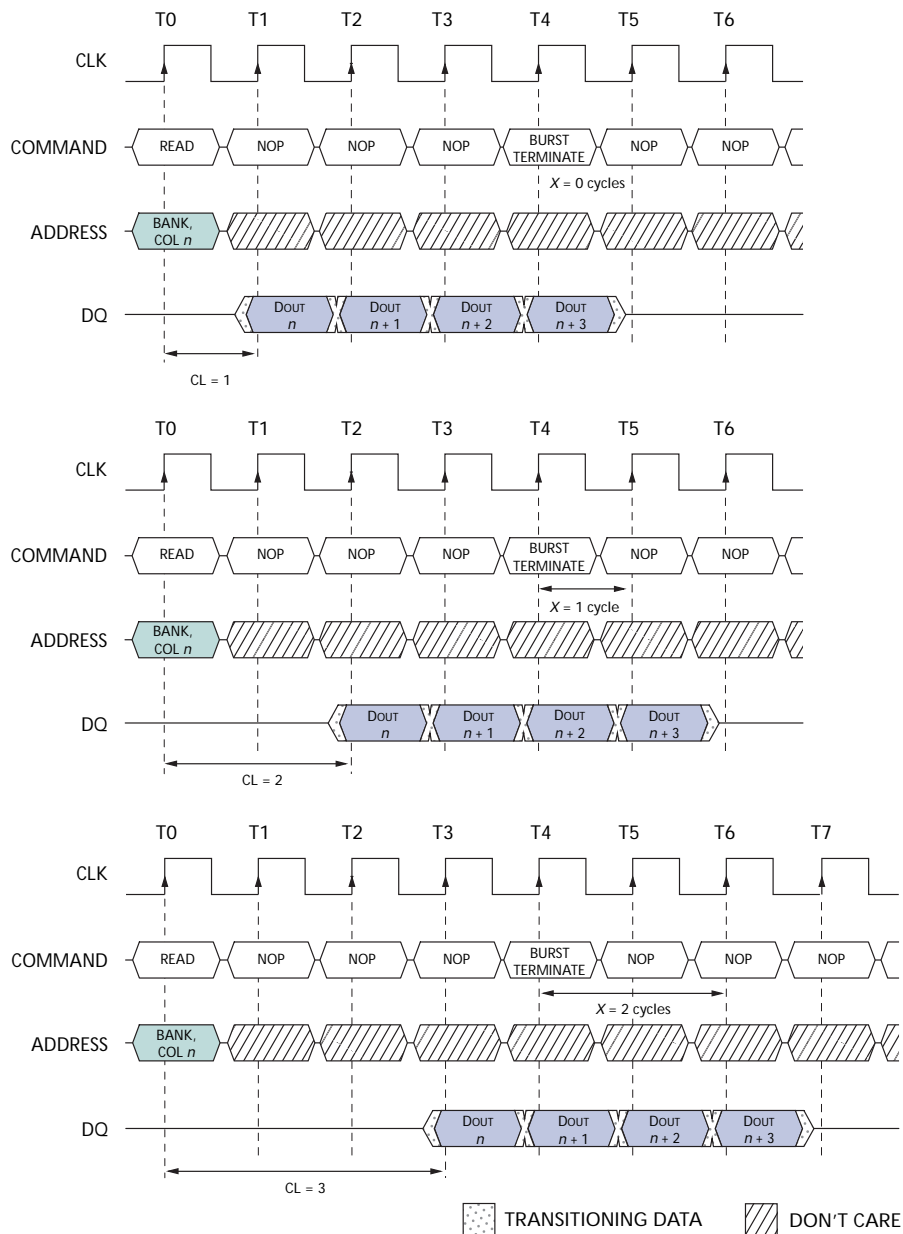

- Notes:
1. Page remains open after a BURST TERMINATE command.
 2. N + 3 is either the last data element of BL = 4 or the last desired data element of a longer burst.
 3. DQM is LOW.

WRITES

WRITE bursts are initiated with a WRITE command, as shown in Figure 20.

The starting column and bank addresses are provided with the WRITE command, and auto precharge either is enabled or disabled for that access. If auto precharge is enabled, the row being accessed is precharged at the completion of the burst. For the WRITE commands used in the following illustrations, auto precharge is disabled.

During WRITE bursts, the first valid data-in element will be registered coincident with the WRITE command. Subsequent data elements will be registered on each successive positive clock edge. Upon completion of a fixed-length burst, assuming no other commands have been initiated, the DQ will remain High-Z, and any additional input data will be ignored (see Figure 21 on page 36). A full-page burst will continue until terminated. (At the end of the page, it will wrap to column 0 and continue.)

Figure 20: WRITE Command

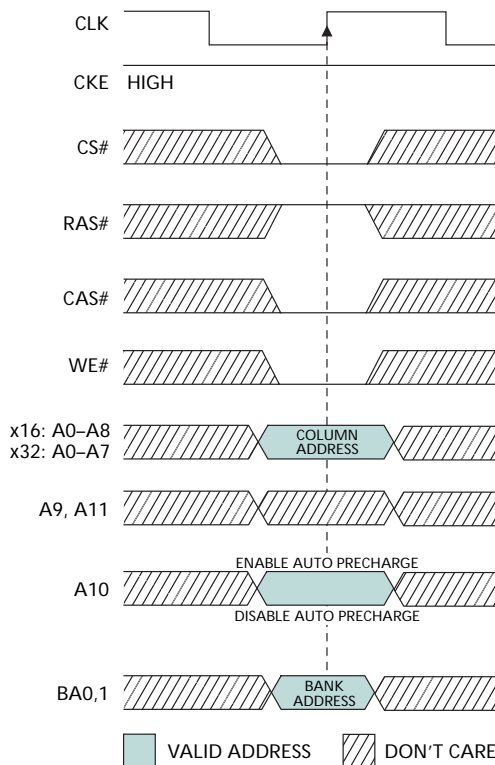

Data for any WRITE burst may be truncated with a subsequent WRITE command, and data for a fixed-length WRITE burst may be immediately followed by data for a WRITE command. The new WRITE command can be issued on any clock following the previous WRITE command, and the data provided coincident with the new command applies to the new command. An example is shown in Figure 21 on page 36. Data $n + 1$ is either the last of a burst of two or the last desired of a longer burst. The 128Mb SDRAM uses a pipelined architecture and, therefore, does not require the $2n$ rule associated with a prefetch architecture. A WRITE command can be initiated on any clock cycle following a previous WRITE command. Full-speed random write accesses within a page can be performed to the same bank, as shown in Figure 22 on page 36, or each subsequent WRITE may be performed to a different bank.

Figure 21: WRITE Burst

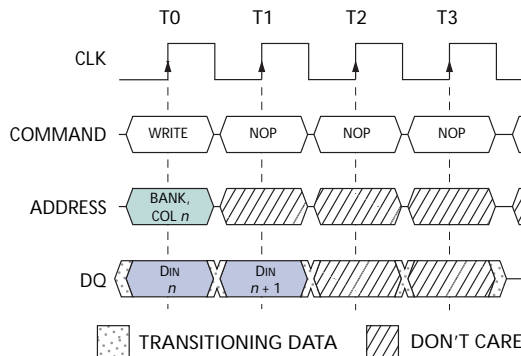

Notes: 1. BL = 2. DQM is LOW.

Figure 22: WRITE-to-WRITE

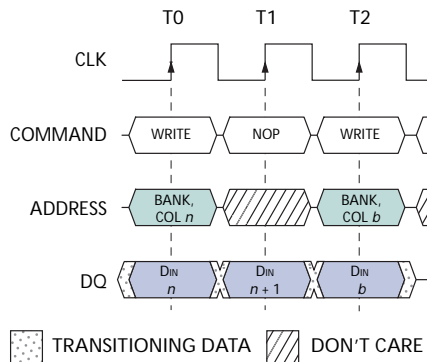

Notes: 1. DQM is LOW. Each WRITE command may be to any bank.

Data for any WRITE burst may be truncated with a subsequent READ command, and data for a fixed-length WRITE burst may be immediately followed by a READ command. After the READ command is registered, the data inputs will be ignored, and writes will not be executed. An example is shown in Figure 24 on page 37. Data $n + 1$ is either the last of a burst of two or the last desired of a longer burst.

Data for a fixed-length WRITE burst may be followed by, or truncated with, a PRECHARGE command to the same bank (provided that auto precharge was not activated), and a full-page WRITE burst may be truncated with a PRECHARGE command to the same bank. The PRECHARGE command should be issued t_{WR} after the clock edge at which the last desired input data element is registered. The auto precharge mode requires a t_{WR} of at least one clock plus time, regardless of frequency.

In addition, when truncating a WRITE burst, the DQM signal must be used to mask input data for the clock edge prior to, and the clock edge coincident with, the PRECHARGE command. An example is shown in Figure 25 on page 38. Data $n + 1$ is either the last of a burst of two or the last desired of a longer burst. Following the PRECHARGE command, a subsequent command to the same bank cannot be issued until t_{RP} is met. The PRECHARGE can be issued coincident with the second clock (see Figure 25 on page 38).

In the case of a fixed-length burst being executed to completion, a PRECHARGE command issued at the optimum time (as described above) provides the same operation that would result from the same fixed-length burst with auto precharge. The disadvantage of the PRECHARGE command is that it requires that the command and address buses be available at the appropriate time to issue the command; the advantage of the PRECHARGE command is that it can be used to truncate fixed-length or full-page bursts.

Figure 23: Random WRITE Cycles

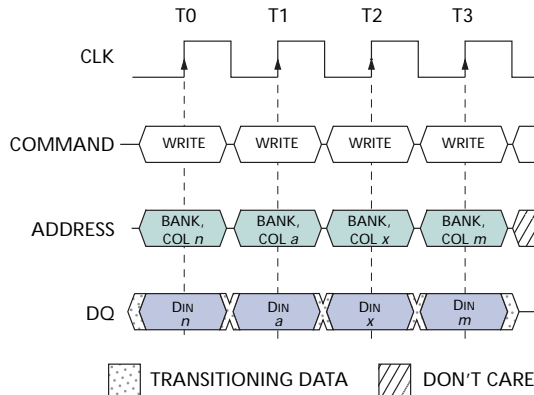

- Notes:
1. Each WRITE command may be to any bank.
 2. DQM is LOW.
 3. Example shows BL = 1 or an interrupting BL > 1.

Figure 24: WRITE-to-READ

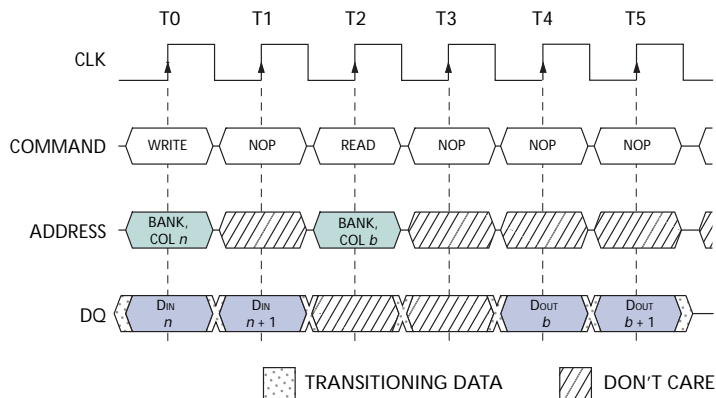

- Notes:
1. The WRITE command may be to any bank, and the READ command may be to any bank.
 2. DQM is LOW.
 3. CL = 2 for illustration.
 4. Data $n + 1$ is either the last data of BL = 1 or the last desired of a longer burst.

Figure 25: WRITE-to-PRECHARGE

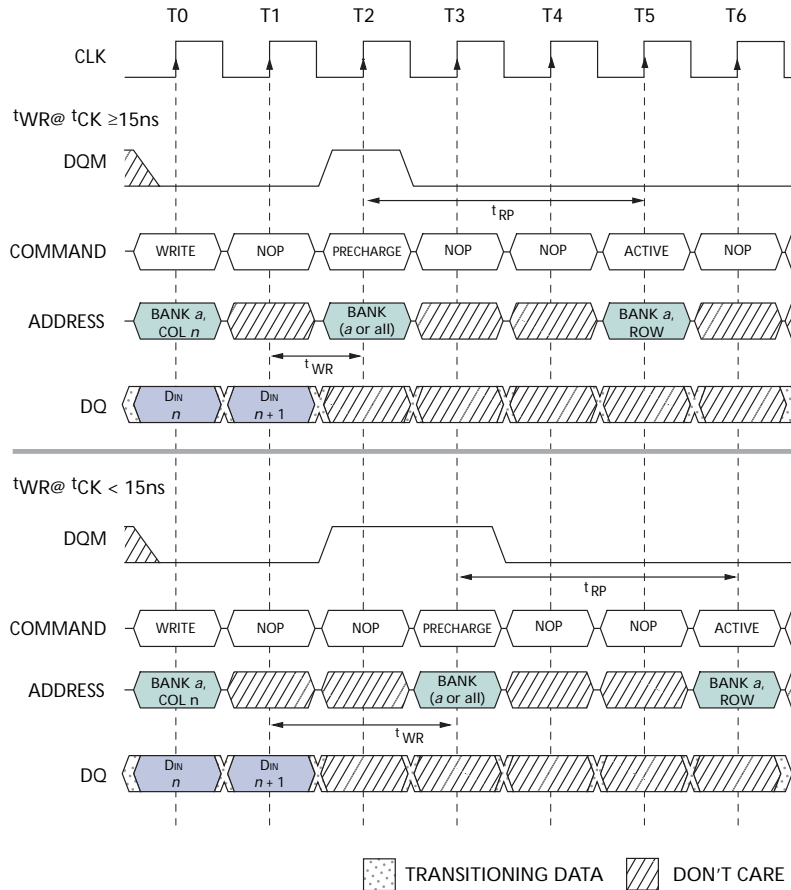

Notes: 1. DQM could remain LOW in this example if the WRITE burst is a fixed length of two.

Fixed-length or full-page WRITE bursts can be truncated with the BURST TERMINATE command. When truncating a WRITE burst, the input data applied coincident with the BURST TERMINATE command will be ignored. The last data written (provided that DQM is LOW at that time) will be the input data applied one clock previous to the BURST TERMINATE command. This is shown in Figure 26, where data n is the last desired data element of a longer burst.

Figure 26: Terminating a WRITE Burst

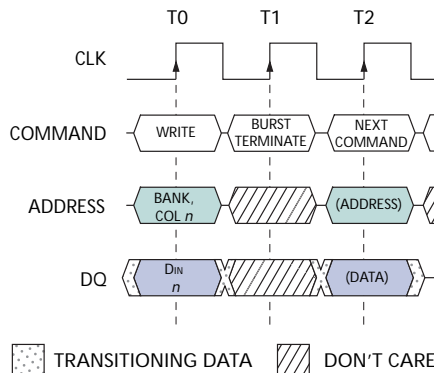

Notes: 1. DQMs are LOW.

Figure 27: PRECHARGE Command

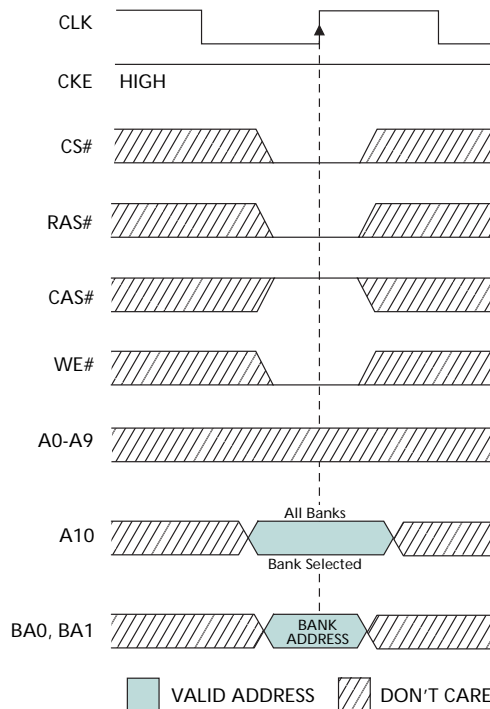

PRECHARGE

The PRECHARGE command (see Figure 27) is used to deactivate the open row in a particular bank or the open row in all banks. The bank(s) will be available for a subsequent row access some specified time (t_{RP}) after the precharge command is issued. Input A10 determines whether one or all banks are to be precharged, and in the case where only one bank is to be precharged, inputs BA0, BA1 select the bank. When all banks are to be precharged, inputs BA0, BA1 are treated as “Don’t Care.” After a bank has been precharged, it is in the idle state and must be activated prior to any READ or WRITE commands being issued to that bank.

POWER-DOWN

Power-down occurs if CKE is registered low coincident with a NOP or COMMAND INHIBIT when no accesses are in progress. If power-down occurs when all banks are idle, this mode is referred to as precharge power-down; if power-down occurs when there is a row active in any bank, this mode is referred to as active power-down. Entering power-down deactivates the input and output buffers, excluding CKE, for maximum power savings while in standby. The device may not remain in the power-down state longer than the refresh period (t_{REF} or $t_{REF_{AT}}$) since no refresh operations are performed in this mode.

The power-down state is exited by registering a NOP or COMMAND INHIBIT and CKE HIGH at the desired clock edge (meeting t_{CKS}). See Figure 28 on page 40.

Figure 28: Power-Down

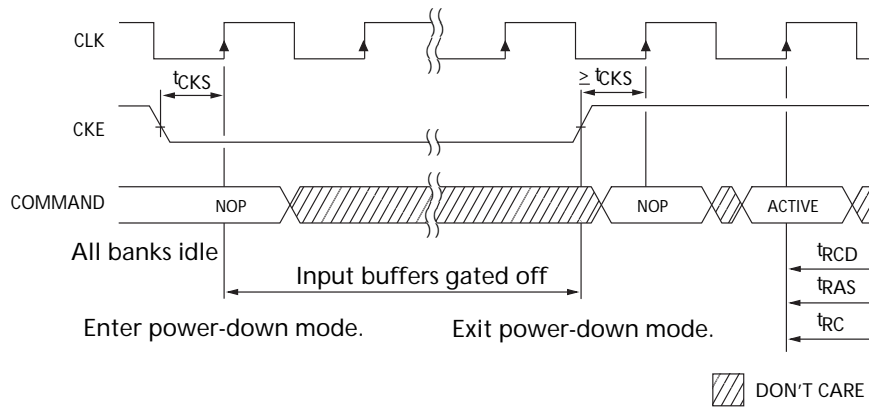

CLOCK SUSPEND

The clock suspend mode occurs when a column access/burst is in progress and CKE is registered low. In the clock suspend mode, the internal clock is deactivated, “freezing” the synchronous logic.

For each positive clock edge on which CKE is sampled LOW, the next internal positive clock edge is suspended. Any command or data present on the input pins at the time of a suspended internal clock edge is ignored; any data present on the DQ pins remains driven; and burst counters are not incremented as long as the clock is suspended. (See examples in Figure 29 and in Figure 30 on page 41.)

Figure 29: Clock Suspend During WRITE Burst

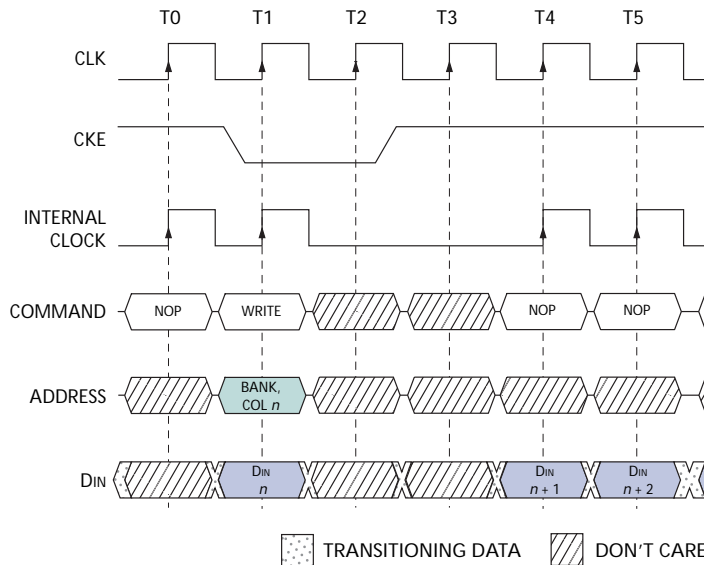

Notes: 1. For this example, burst length = 4 or greater, and DM is LOW.

Clock suspend mode is exited by registering CKE HIGH; the internal clock and related operation will resume on the subsequent positive clock edge.

Burst Read/Single Write

The burst read/single write mode is entered by programming the write burst mode bit (M9) in the mode register to a logic 1. In this mode, all WRITE commands result in the access of a single column location (burst of 1), regardless of the programmed burst length. READ commands access columns according to the programmed burst length and sequence, just as in the normal mode of operation (M9 = 0).

Figure 30: Clock Suspend During READ Burst

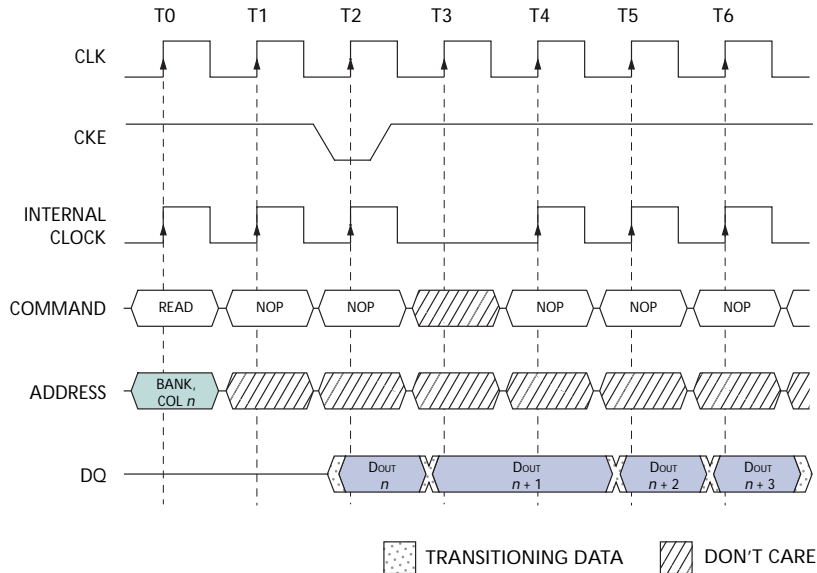

Notes: 1. For this example, CL = 2, BL = 4 or greater, and DQM is LOW.

CONCURRENT Auto Precharge

An access command (READ or WRITE) to another bank while an access command with auto precharge enabled is executing is not allowed by SDRAMs, unless the SDRAM supports concurrent auto precharge. Micron SDRAMs support concurrent auto precharge. Four cases where concurrent auto precharge occurs are defined below.

READ with Auto Precharge

- Interrupted by a READ (with or without auto precharge): A READ to bank m will interrupt a READ on bank n , CL later. The precharge to bank n will begin when the READ to bank m is registered (Figure 31 on page 42).
- Interrupted by a WRITE (with or without auto precharge): A WRITE to bank m will interrupt a READ on bank n when registered. DQM should be used 2 clocks prior to the WRITE command to prevent bus contention. The precharge to bank n will begin when the WRITE to bank m is registered (Figure 32 on page 42).

Figure 31: READ With Auto Precharge Interrupted by a READ

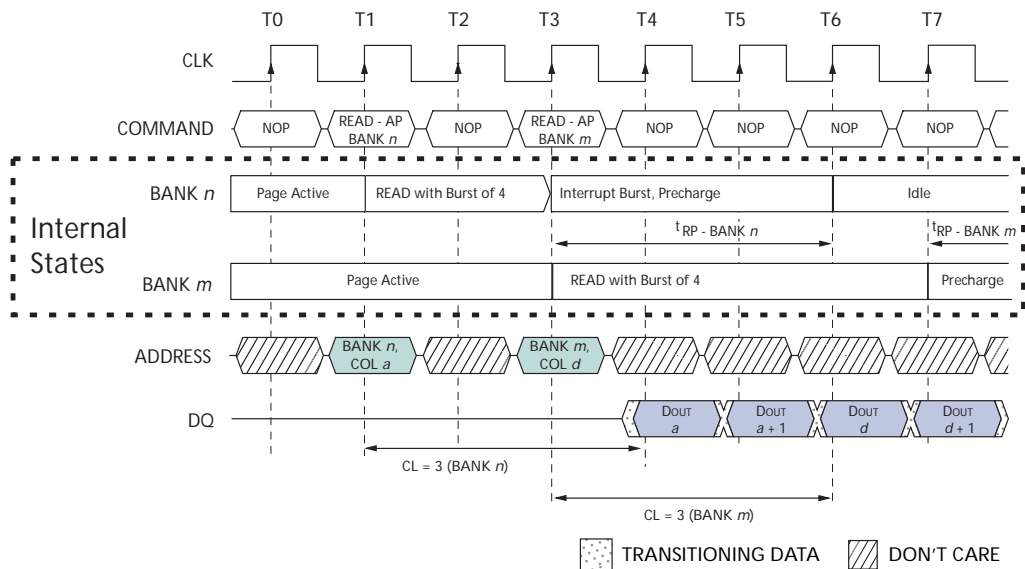

Notes: 1. DQM is LOW, BL = 4 or greater, and CL = 3.

Figure 32: READ With Auto Precharge Interrupted by a WRITE

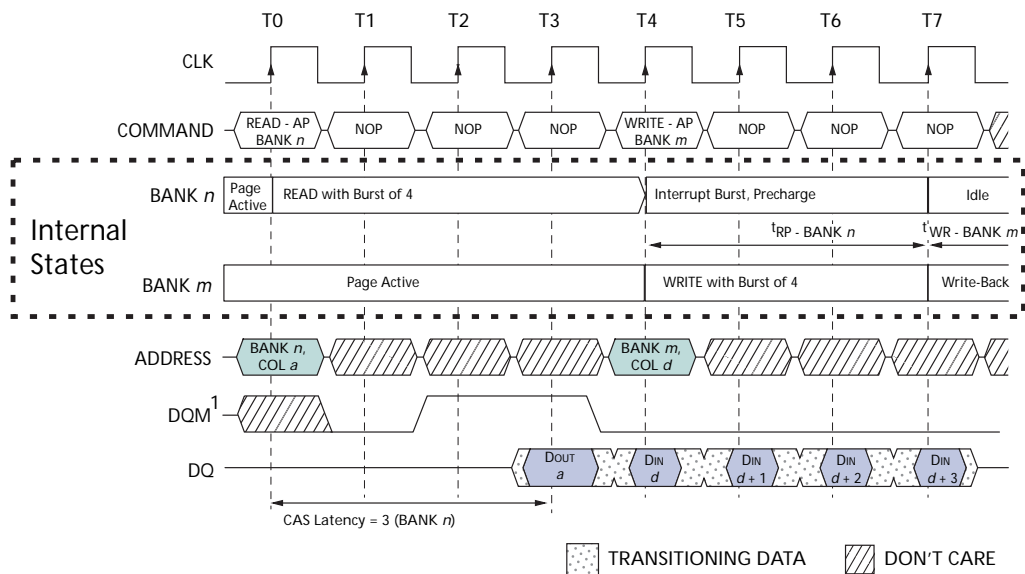

Notes: 1. DQM is HIGH at T2 to prevent DOUT a + 1 from contending with DIN d at T4.

WRITE with Auto Precharge

- Interrupted by a READ (with or without auto precharge): A READ to bank m will interrupt a WRITE on bank n when registered, with the data-out appearing CL later. The precharge to bank n will begin after t_{WR} is met, where t_{WR} begins when the READ to bank m is registered. The last valid WRITE to bank n will be data-in registered 1 clock prior to the READ to bank m (Figure 33 on page 43).

- Interrupted by a WRITE (with or without auto precharge): A WRITE to bank *m* will interrupt a WRITE on bank *n* when registered. The precharge to bank *n* will begin after t_{WR} is met, where t_{WR} begins when the WRITE to bank *m* is registered. The last valid data WRITE to bank *n* will be data registered 1 clock prior to a WRITE to bank *m* (Figure 34).

Figure 33: WRITE With Auto Precharge Interrupted by a READ

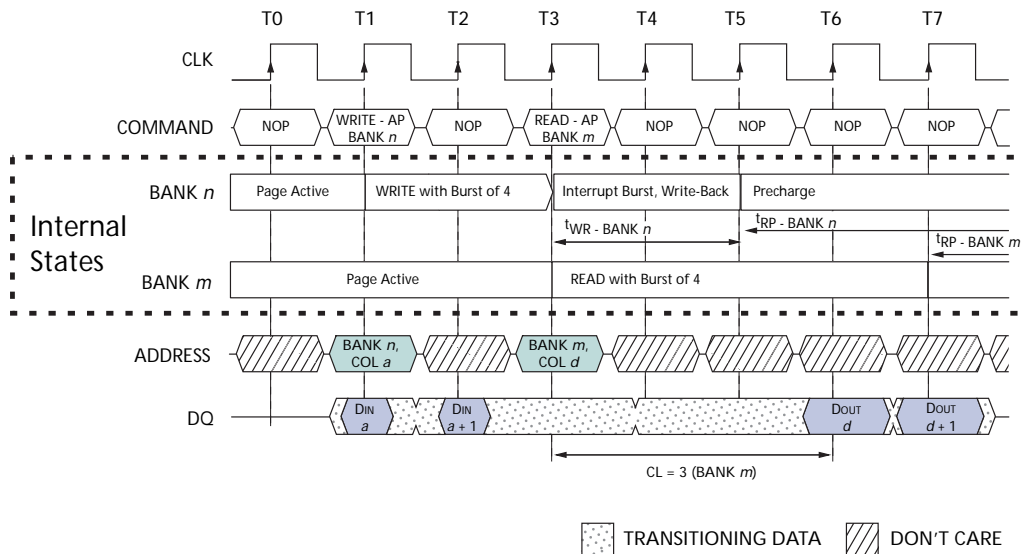

Notes: 1. DQM is LOW.

Figure 34: WRITE With Auto Precharge Interrupted by a WRITE

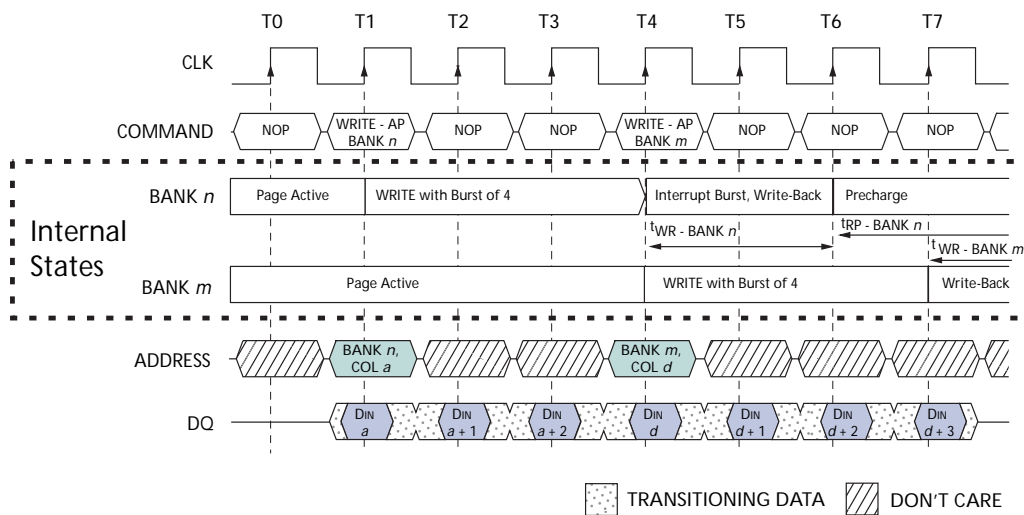

Notes: 1. DQM is LOW.

Table 9: Truth Table – CKE
Notes 1–4 apply to entire table

CKE _{n-1}	CKE _n	Current State	Comand _n	Action	Notes
L	L	Power-down	X	Maintain power-down	
		Self refresh	X	Maintain self refresh	
		Clock suspend	X	Maintain clock suspend	
L	H	Power-down	COMMAND INHIBIT or NOP	Exit power-down	5
		Self refresh	COMMAND INHIBIT or NOP	Exit self refresh	6
		Clock suspend	X	Exit clock suspend	7
H	L	All banks idle	COMMAND INHIBIT or NOP	Power-down entry	
		All banks idle	AUTO REFRESH	self refresh entry	
		Reading or writing	WRITE or NOP	Clock suspend entry	
H	H		See Table 10 on page 45		

- Notes:
1. CKE_n is the logic state of CKE at clock edge *n*; CKE_{n-1} was the state of CKE at the previous clock edge.
 2. Current state is the state of the SDRAM immediately prior to clock edge *n*.
 3. COMMAND_n is the command registered at clock edge *n*, and ACTION_n is a result of COMMAND_n.
 4. All states and sequences not shown are illegal or reserved.
 5. Exiting power-down at clock edge *n* will put the device in the all banks idle state in time for clock edge *n* + 1 (provided that ^tCKS is met).
 6. Exiting self refresh at clock edge *n* will put the device in the all banks idle state after ^tXSR is met. COMMAND INHIBIT or NOP commands should be issued on any clock edges occurring during the ^tXSR period. A minimum of two NOP commands must be provided during ^tXSR period.
 7. After exiting clock suspend at clock edge *n*, the device will resume operation and recognize the next command at clock edge *n* + 1.

Table 10: Truth Table – Current State Bank *n*, Command to Bank *n*

Notes 1–6 apply to entire table; notes appear below table

Current State	CS#	RAS#	CAS#	WE#	Command (Action)	Notes
Any	H	X	X	X	COMMAND INHIBIT (NOP/Continue previous operation)	
	L	H	H	H	NO OPERATION (NOP/Continue previous operation)	
Idle	L	L	H	H	ACTIVE (Select and activate row)	
	L	L	L	H	AUTO REFRESH	7
	L	L	L	L	LOAD MODE REGISTER	7
	L	L	H	L	PRECHARGE	11
Row active	L	H	L	H	READ (Select column and start READ burst)	10
	L	H	L	L	WRITE (Select column and start WRITE burst)	10
	L	L	H	L	PRECHARGE (Deactivate row in bank or banks)	8
Read (auto precharge disabled)	L	H	L	H	READ (Select column and start new READ burst)	10
	L	H	L	L	WRITE (Select column and start WRITE burst)	10
	L	L	H	L	PRECHARGE (Truncate READ burst, start PRECHARGE)	8
	L	H	H	L	BURST TERMINATE	9
Write (auto precharge disabled)	L	H	L	H	READ (Select column and start READ burst)	10
	L	H	L	L	WRITE (Select column and start new WRITE burst)	10
	L	L	H	L	PRECHARGE (Truncate WRITE burst, start PRECHARGE)	8
	L	H	H	L	BURST TERMINATE	9

- Notes:
- This table applies when CKE_{n-1} was HIGH and CKE_n is HIGH (see Table 9 on page 44) and after t^{XSR} has been met (if the previous state was self refresh).
 - This table is bank-specific, except where noted; that is, the current state is for a specific bank and the commands shown are those allowed to be issued to that bank when in that state. Exceptions are covered in the notes below.
 - Current state definitions:
 - Idle: The bank has been precharged, and t^{RP} has been met.
 - Row active: A row in the bank has been activated, and t^{RCD} has been met. No data bursts/accesses and no register accesses are in progress.
 - Read: A READ burst has been initiated, with auto precharge disabled, and has not yet terminated or been terminated.
 - Write: A WRITE burst has been initiated, with auto precharge disabled, and has not yet terminated or been terminated.
 - The following states must not be interrupted by a command issued to the same bank. COMMAND INHIBIT or NOP commands or allowable commands to the other bank should be issued on any clock edge occurring during these states. Allowable commands to the other bank are determined by its current state and Table 10 and according to Table 11 on page 47.
 - Precharging: Starts with registration of a PRECHARGE command and ends when t^{RP} is met. After t^{RP} is met, the bank will be in the idle state.
 - Row activating: Starts with registration of an ACTIVE command and ends when t^{RCD} is met. After t^{RCD} is met, the bank will be in the row active state.
 - Read w/auto precharge enabled: Starts with registration of a READ command with auto precharge enabled and ends when t^{RP} has been met. After t^{RP} is met, the bank will be in the idle state.
 - Write w/auto precharge enabled: Starts with registration of a WRITE command with auto precharge enabled and ends when t^{RP} has been met. After t^{RP} is met, the bank will be in the idle state.

5. The following states must not be interrupted by any executable command; COMMAND INHIBIT or NOP commands must be applied on each positive clock edge during these states. Refreshing starts with registration of an AUTO REFRESH command and ends when t_{RFC} is met. After t_{RFC} is met, the SDRAM will be in the all banks idle state.
 - Accessing mode: Starts with registration of a LOAD MODE REGISTER command and register: ends when t_{MRD} has been met. After t_{MRD} is met, the SDRAM will be in the all banks idle state.
 - Precharging all: Starts with registration of a PRECHARGE ALL command and ends when t_{RP} is met. After t_{RP} is met, all banks will be in the idle state.
6. All states and sequences not shown are illegal or reserved.
7. Not bank-specific; requires that all banks are idle.
8. May or may not be bank-specific; if all banks are to be precharged, all must be in a valid state for precharging.
9. Not bank-specific; BURST TERMINATE affects the most recent READ or WRITE burst, regardless of bank.
10. READs or WRITEs listed in the Command (Action) column include READs or WRITEs with auto precharge enabled and READs or WRITEs with auto precharge disabled.
11. Does not affect the state of the bank and acts as a NOP to that bank.

Table 11: Truth Table – CURRENT STATE BANK *n*, COMMAND to BANK *m*

Notes 1–6 apply to entire table; notes appear below and on next page

Current State	CS#	RAS#	CAS#	WE#	Command (Action)	Notes
Any	H	X	X	X	COMMAND INHIBIT (NOP/continue previous operation)	
	L	H	H	H	NO OPERATION (NOP/continue previous operation)	
Idle	X	X	X	X	Any command otherwise allowed to bank <i>m</i>	
Row Activating, active, or precharging	L	L	H	H	ACTIVE (Select and activate row)	
	L	H	L	H	READ (Select column and start READ burst)	7
	L	H	L	L	WRITE (Select column and start WRITE burst)	7
	L	L	H	L	PRECHARGE	
Read (auto precharge disabled)	L	L	H	H	ACTIVE (Select and activate row)	
	L	H	L	H	READ (Select column and start new READ burst)	7, 10
	L	H	L	L	WRITE (Select column and start WRITE burst)	7, 11
	L	L	H	L	PRECHARGE	9
Write (auto precharge disabled)	L	L	H	H	ACTIVE (Select and activate row)	
	L	H	L	H	READ (Select column and start READ burst)	7, 12
	L	H	L	L	WRITE (Select column and start new WRITE burst)	7, 13
	L	L	H	L	PRECHARGE	9
Read (with auto precharge)	L	L	H	H	ACTIVE (Select and activate row)	
	L	H	L	H	READ (Select column and start new READ burst)	7, 8, 14
	L	H	L	L	WRITE (Select column and start WRITE burst)	7, 8, 15
	L	L	H	L	PRECHARGE	9
Write (with auto precharge)	L	L	H	H	ACTIVE (Select and activate row)	
	L	H	L	H	READ (Select column and start READ burst)	7, 8, 16
	L	H	L	L	WRITE (Select column and start new WRITE burst)	7, 8, 17
	L	L	H	L	PRECHARGE	9

- Notes:
- This table applies when CKE_{n-1} was HIGH and CKE_n is HIGH (see Table 9 on page 44) and after t^*_{XSR} has been met (if the previous state was self refresh).
 - This table describes alternate bank operation, except where noted; that is, the current state is for bank *n* and the commands shown are those allowed to be issued to bank *m* (assuming that bank *m* is in such a state that the given command is allowable). Exceptions are covered in the notes below.
 - Current state definitions:
 - Idle: The bank has been precharged, and t^*_{RP} has been met.
 - Row active: A row in the bank has been activated, and t^*_{RCD} has been met. No data bursts/accesses and no register accesses are in progress.
 - Read: A READ burst has been initiated, with auto precharge disabled, and has not yet terminated or been terminated.
 - Write: A WRITE burst has been initiated, with auto precharge disabled, and has not yet terminated or been terminated.
 - Read w/auto precharge enabled: Starts with registration of a READ command with auto precharge enabled and ends when t^*_{RP} has been met. After t^*_{RP} is met, the bank will be in the idle state.
 - Write w/auto precharge enabled: Starts with registration of a WRITE command with auto precharge enabled and ends when t^*_{RP} has been met. After t^*_{RP} is met, the bank will be in the idle state.
 - AUTO REFRESH, SELF REFRESH, and LOAD MODE REGISTER commands may only be issued when all banks are idle.
 - A BURST TERMINATE command cannot be issued to another bank; it applies to the bank represented by the current state only.

6. All states and sequences not shown are illegal or reserved.
7. READs or WRITEs to bank *m* listed in the Command (Action) column include READs or WRITEs with auto precharge enabled and READs or WRITEs with auto precharge disabled.
8. Concurrent auto precharge: Bank *n* will initiate the auto precharge command when its burst has been interrupted by bank *m*'s burst.
9. Burst in bank *n* continues as initiated.
10. For a READ without auto precharge interrupted by a READ (with or without auto precharge), the READ to bank *m* will interrupt the READ on bank *n*, CL later (see Figure 14 on page 29).
11. For a READ without auto precharge interrupted by a WRITE (with or without auto precharge), the WRITE to bank *m* will interrupt the READ on bank *n* when registered (see Figure 16 and Figure 17 on page 31). DQM should be used one clock prior to the WRITE command to prevent bus contention.
12. For a WRITE without auto precharge interrupted by a READ (with or without auto precharge), the READ to bank *m* will interrupt the WRITE on bank *n* when registered (see Figure 24 on page 37) with the data-out appearing CL later. The last valid WRITE to bank *n* will be data-in registered 1 clock prior to the READ to bank *m*.
13. For a WRITE without auto precharge interrupted by a WRITE (with or without auto precharge), the WRITE to bank will interrupt the WRITE on bank *n* when registered (see Figure 22 on page 36). The last valid WRITE to bank *n* will be data-in registered 1 clock prior to the READ to bank *m*.
14. For a READ with auto precharge interrupted by a READ (with or without auto precharge), the READ to bank *m* will interrupt the READ on bank *n*, CL later. The PRECHARGE to bank *n* will begin when the READ to bank *m* is registered (see Figure 31 on page 42).
15. For a READ with auto precharge interrupted by a WRITE (with or without auto precharge), the WRITE to bank *m* will interrupt the READ on bank *n* when registered. DQM should be used 2 clocks prior to the WRITE command to prevent bus contention. The PRECHARGE to bank *n* will begin when the WRITE to bank *m* is registered (see Figure 32 on page 42).
16. For a WRITE with auto precharge interrupted by a READ (with or without auto precharge), the READ to bank *m* will interrupt the WRITE on bank *n* when registered, with the data-out appearing CL later. The PRECHARGE to bank *n* will begin after t^{WR} is met, where t^{WR} begins when the READ to bank *m* is registered. The last valid WRITE bank *n* will be data-in registered 1 clock prior to the READ to bank *m* (see Figure 33 on page 43).
17. For a WRITE with auto precharge interrupted by a WRITE (with or without auto precharge), the WRITE to bank *m* will interrupt the WRITE on bank *n* when registered. The PRECHARGE to bank *n* will begin after t^{WR} is met, where t^{WR} begins when the WRITE to bank *m* is registered. The last valid WRITE to bank *n* will be data registered 1 clock to the WRITE to bank *m* (see Figure 34 on page 43).

Electrical Specifications

Stresses greater than those listed in Table 12 may cause permanent damage to the device. This is a stress rating only, and functional operation of the device at these or any other conditions above those indicated in the operational sections of this specification is not implied. Exposure to absolute maximum rating conditions for extended periods may affect reliability.

Table 12: Absolute Maximum Ratings

Parameter	Min	Max	Rating
Voltage on VDD/VDDQ supply relative to Vss (LC devices)	-1	+4.6	V
Relative to Vss (V devices)	0.5	+3.6	V
Voltage on inputs, NC or I/O pins relative to Vss (LC devices)	-1	+4.6	V
Relative to Vss (V devices)	-0.5	+3.6	V
Operating temperature			°C
T _A (commercial)	0	+70	
T _A (industrial)	-40	+85	
T _A (automotive)	-40	+105	
Storage temperature (plastic)	-55	+150	°C

Temperature and Thermal Impedance

It is imperative that the Mobile SDRAM device's temperature specifications, shown in Table 13 on page 50, be maintained to ensure the junction temperature is in the proper operating range to meet data sheet specifications. An important step in maintaining the proper junction temperature is using the device's thermal impedances correctly. The thermal impedances are listed in Table 14 on page 50 for the applicable die revision and packages being made available. These thermal impedance values vary according to the density, package, and particular design used for each device.

Incorrectly using thermal impedances can produce significant errors. Read Micron technical note TN-00-08, "Thermal Applications" prior to using the thermal impedances listed in Table 14 on page 50. To ensure the compatibility of current and future designs, contact Micron Applications Engineering to confirm thermal impedance values.

The SDRAM device's safe junction temperature range can be maintained when the T_C specification is not exceeded. In applications where the device's ambient temperature is too high, use of forced air and/or heat sinks may be required to satisfy the case temperature specifications.

Table 13: Temperature Limits

Parameter	Symbol	Min	Max	Units	Notes
Operating case temperature: Commercial Industrial Automotive	T_C	0 -40 -40	80 90 105	°C	1, 2, 3, 4
Junction temperature: Commercial Industrial Automotive	T_J	0 -40 -40	85 95 110	°C	3
Ambient temperature: Commercial Industrial Automotive	T_A	0 -40 -40	70 85 105	°C	3, 5
Peak reflow temperature	T_{PEAK}	-	260	°C	

- Notes:
1. MAX operating case temperature, T_C , is measured in the center of the package on the top side of the device, as shown in Figures 35, 36, and 37 on page 51.
 2. Device functionality is not guaranteed if the device exceeds maximum T_C during operation.
 3. All temperature specifications must be satisfied.
 4. The case temperature should be measured by gluing a thermocouple to the top center of the component. This should be done with a 1mm bead of conductive epoxy, as defined by the JEDEC EIA/JESD51 standards. Care should be taken to ensure the thermocouple bead is touching the case.
 5. Operating ambient temperature surrounding the package.

Table 14: Thermal Impedance Simulated Values

Die Revision	Package	Substrate	θ_{JA} (°C/W) Airflow = 0m/s	θ_{JA} (°C/W) Airflow = 1m/s	θ_{JA} (°C/W) Airflow = 2m/s	θ_{JB} (°C/W)	θ_{JC} (°C/W)
G	54-pin TSOP ⁴	2-layer	86.2	67.8	62	46.9	11.3
		4-layer	58.9	50.7	47.6	41.5	
	54-ball VFBGA	2-layer	72.1	57.3	50.6	36.0	4.1
		4-layer	54.5	46.6	42.8	35.5	
	90-ball VFBGA	2-layer	64.6	50.8	45.3	37.5	1.8
		4-layer	48.2	41.1	38.1	32.1	

- Notes:
1. For designs expected to last beyond the die revision listed, contact Micron Applications Engineering to confirm thermal impedance values.
 2. Thermal resistance data is sampled from multiple lots, and the values should be viewed as typical.
 3. These are estimates; actual results may vary.
 4. Thermal impedance values were obtained using the 128Mb SDRAM 54-pin TSOP.

Figure 35: Example Temperature Test Point Location, 54-Pin TSOP: Top View

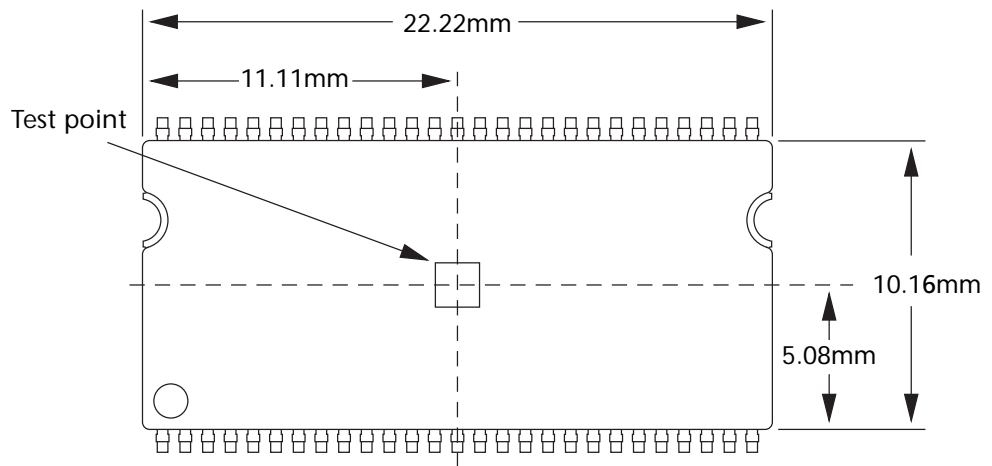

Figure 36: Example Temperature Test Point Location, 54-Ball VFBGA: Top View

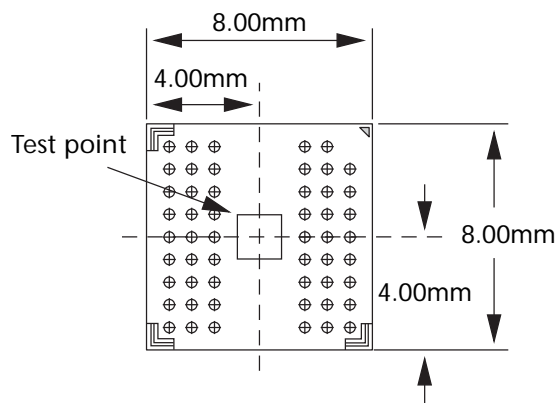

Figure 37: Example Temperature Test Point Location, 90-Ball VFBGA: Top View

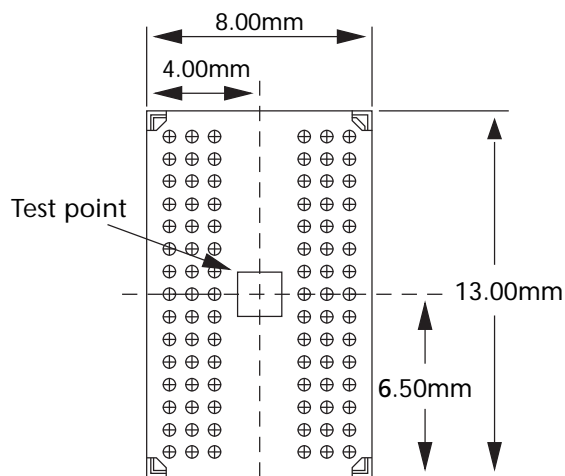

Table 15: DC Electrical Characteristics and Operating Conditions (LC Version)

 Notes 1, 6 apply to entire table; notes appear on page 57; $V_{DD} = +3.3V \pm 0.3V$, $V_{DDQ} = +3.3V \pm 0.3V$

Parameter/Condition	Symbol	Min	Max	Units	Notes
Supply voltage	V_{DD}	3	3.6	V	
I/O supply voltage	V_{DDQ}	3	3.6	V	
Input high voltage: Logic 1; All inputs	V_{IH}	2	$V_{DD} + 0.3$	V	22
Input low voltage: Logic 0; All inputs	V_{IL}	-0.3	0.8	V	22
Data output high voltage: Logic 1; All inputs	V_{OH}	2.4	-	V	
Data output low voltage: Logic 0; All inputs	V_{OL}	-	0.4	V	
Input leakage current: Any input $0V \leq V_{IN} \leq V_{DD}$ (All other pins not under test = 0V)	I_I	-5	5	μA	
Output leakage current: DQ are disabled; $0V \leq V_{OUT} \leq V_{DDQ}$	I_{OZ}	-5	5	μA	

Table 16: DC Electrical Characteristics and Operating Conditions (V Version)

 Notes 1, 6 apply to entire table; notes appear on page 57; $V_{DD} = 2.5 \pm 0.2V$, $V_{DDQ} = +2.5V \pm 0.2V$ or $+1.8V \pm 0.15V$

Parameter/Condition	Symbol	Min	Max	Units	Notes
Supply voltage	V_{DD}	2.3	2.7	V	
I/O supply voltage	V_{DDQ}	1.65	2.7	V	
Input high voltage: Logic 1; All inputs	$V_{IH} (DQ)$	1.25	$V_{DDQ} + 0.3$	V	22
	$V_{IH} (non-DQ)$	1.25	$V_{DD} + 0.3$		
Input low voltage: Logic 0; All inputs	V_{IL}	-0.3	+0.55	V	22
Data output high voltage: Logic 1; All inputs	V_{OH}	$V_{DDQ} - 0.2$	-	V	
Data output low voltage: Logic 0; All inputs	V_{OL}	-	0.2	V	
Input leakage current: Any input $0V \leq V_{IN} \leq V_{DD}$ (All other pins not under test = 0V)	I_I	-5	5	μA	
Output leakage current: DQ are disabled; $0V \leq V_{OUT} \leq V_{DDQ}$	I_{OZ}	-5	5	μA	

Table 17: Electrical Characteristics and Recommended AC Operating Conditions

Notes 5, 6, 7, 8, 9, 11 apply to entire table; notes appear on page 57

Ac Characteristics		Symbol	-75M		-8		-10		Units	Notes
Parameter			Min	Max	Min	Max	Min	Max		
Access time from CLK (positive edge)	CL = 3	$t_{AC}^{(3)}$	-	5.4	-	7	-	7	ns	
	CL = 2	$t_{AC}^{(2)}$	-	6	-	8	-	8	ns	
	CL = 1	$t_{AC}^{(1)}$	-	na	-	19	-	22	ns	
Address hold time		t_{AH}	0.8	-	1	-	1	-	ns	
Address setup time		t_{AS}	1.5	-	2.5	-	2.5	-	ns	
CLK high-level width		t_{CH}	3	-	3	-	3	-	ns	
CLK low-level width		t_{CL}	2.5	-	3	-	3	-	ns	
Clock cycle time	CL = 3	$t_{CK}^{(3)}$	7.5	-	8	-	10	-	ns	23
	CL = 2	$t_{CK}^{(2)}$	9.6	-	9.6	-	12	-	ns	23
	CL = 1	$t_{CK}^{(1)}$	n/a	-	20	-	25	-	ns	23
CKE hold time		t_{CKH}	1	-	1	-	1	-	ns	
CKE setup time		t_{CKS}	2.5	-	2.5	-	2.5	-	ns	
CS#, RAS#, CAS#, WE#, DQM hold time		t_{CMH}	0.8	-	1	-	1	-	ns	
CS#, RAS#, CAS#, WE#, DQM setup time		t_{CMS}	1.5	-	2.5	-	2.5	-	ns	
Data-in hold time		t_{DH}	0.8	-	1	-	1	-	ns	
Data-in setup time		t_{DS}	1.5	-	2.5	-	2.5	-	ns	
Data-out High-Z time	CL = 3	$t_{HZ}^{(3)}$	-	5.4	-	7	-	7	ns	10
	CL = 2	$t_{HZ}^{(2)}$	-	6	-	8	-	8	ns	10
	CL = 1	$t_{HZ}^{(1)}$	-	na	-	19	-	22	ns	10
Data-out Low-Z time		t_{LZ}	1	-	1	-	1	-	ns	
Data-out hold time (load)		t_{OH}	2.5	-	2.5	-	2.5	-	ns	27
Data-out hold time (no load)		t_{OHN}	1.8	-	1.8	-	1.8	-	ns	
ACTIVE-to-PRECHARGE command		t_{RAS}	44	120,000	48	120,000	50	120,000	ns	
ACTIVE-to-ACTIVE command period		t_{RC}	66	-	80	-	100	-	ns	
ACTIVE-to-READ or WRITE delay		t_{RCD}	19	-	20	-	20	-	ns	
Refresh period (4,096 rows)		t_{REF}	-	64	-	64	-	64	ms	
Refresh period - (AT) (4,096 rows)		$t_{REF_{AT}}$	-	16	-	16	-	16	ms	
AUTO REFRESH command period		t_{RFC}	66	-	80	-	100	-	ns	
PRECHARGE command period		t_{RP}	19	-	20	-	20	-	ns	
ACTIVE bank <i>a</i> to ACTIVE bank <i>b</i> command		t_{RRD}	2	-	2	-	2	-	t_{CK}	
Transition time		t_T	0.3	1.2	0.5	1.2	0.5	1.2	ns	7
WRITE recovery time Auto precharge mode (a) Manual precharge mode (m)		$t_{WR}^{(a)}$	1 CLK +7.5ns	-	1 CLK +7ns	-	1 CLK +5ns	-	-	24
		$t_{WR}^{(m)}$	15	-	15	-	15	-	ns	25
Exit SELF REFRESH to ACTIVE command		t_{XSR}	67	-	80	-	100	-	ns	20

Table 18: AC Functional Characteristics

Notes 5, 6, 7, 8, 9, 11 apply to entire table; notes appear on page 57

Parameter	Symbol	-75M	-8	-10	Units	Notes	
READ/WRITE command to READ/WRITE command	t_{CCD}	1	1	1	t_{CK}	17	
CKE to clock disable or power-down entry mode	t_{CKED}	1	1	1	t_{CK}	14	
CKE to clock enable or power-down exit setup mode	t_{PED}	1	1	1	t_{CK}	14	
DQM to input data delay	t_{DQD}	0	0	0	t_{CK}	17	
DQM to data mask during WRITES	t_{DQM}	0	0	0	t_{CK}	17	
DQM to data High-Z during READs	t_{DQZ}	2	2	2	t_{CK}	17	
WRITE command to input data delay	t_{DWD}	0	0	0	t_{CK}	17	
Data-in to ACTIVE command	t_{DAL}	5	5	5	t_{CK}	15, 21	
Data-in to PRECHARGE command	t_{DPL}	2	2	2	t_{CK}	16, 21	
Last data-in to burst STOP command	t_{BDL}	1	1	1	t_{CK}	17	
Last data-in to new READ/WRITE command	t_{CDL}	1	1	1	t_{CK}	17	
Last data-in to PRECHARGE command	t_{RDL}	2	2	2	t_{CK}	16, 21	
LOAD MODE REGISTER command to ACTIVE or REFRESH command	t_{MRD}	2	2	2	t_{CK}	26	
Data-out to High-Z from PRECHARGE command	CL = 3	$t_{ROH(3)}$	3	3	3	t_{CK}	17
	CL = 2	$t_{ROH(2)}$	2	2	2	t_{CK}	17
	CL = 1	$t_{ROH(1)}$		1	1	t_{CK}	17

Table 19: IDD Specifications and Conditions (x16)

Notes 1, 3, 6, 11, 13, 31 apply to entire table; notes appear on page 57; VDD = VDDQ = +3.3V ±0.3V or VDD = VDDQ = 2.5V ±0.2V or VDD = +2.5V ±0.2V, VDDQ = +1.8V ±0.15V

Parameter/Condition	Symbol	Max			Units	Notes	
		-75M	-8	-10			
Operating current: Active mode; Burst = 2; READ or WRITE; $t_{RC} = t_{RC}(\text{MIN})$	IDD1	130	130	100	mA	18, 19	
Standby current: Power-down mode; All banks idle; CKE = LOW	IDD2	450	450	450	μA	12, 33	
Standby current: Active mode; CKE = HIGH; CS# = HIGH; All banks active after t_{RCD} met; No accesses in progress	IDD3	40	40	35	mA	19	
Operating current: Burst mode; Page burst; READ or WRITE; All banks active	IDD4	115	100	95	mA	18, 19	
Auto refresh current: CKE = HIGH; CS# = HIGH	$t_{RFC} = t_{RFC}(\text{MIN})$	IDD5	225	210	170	mA	12, 18, 19, 32, 33
	$t_{RFC} = 15.625\mu\text{s}$	IDD6	3	3	3	mA	
	$t_{RFC} = 3.906\mu\text{s(AT)}$	IDD6	6	6	6	mA	

Table 20: IDD7 Self Refresh Current Options (x16)

Note 4 applies to entire table; note appears on page 57; VDD = VDDQ = +3.3V ±0.3V or VDD = VDDQ = 2.5V ±0.2V or VDD = +2.5V ±0.2V, VDDQ = +1.8V ±0.15V

Temperature-Compensated Self Refresh (TCSR) Parameter/Condition	Max Temperature	-75M/-8/-10	Units
Self refresh current: CKE < 0.2V (E4 = 1, E3 = 1)	85°C	800	μA
Self refresh current: CKE < 0.2V (E4 = 0, E3 = 0)	70°C	500	μA
Self refresh current: CKE < 0.2V (E4 = 0, E3 = 1)	45°C	350	μA
Self refresh current: CKE < 0.2V (E4 = 1, E3 = 0)	15°C	300	μA

Table 21: IDD Specifications And Conditions (x32)

Notes 1, 3, 6, 11, 13, 31 apply to entire table; notes appear on page 57; VDD = VDDQ = +3.3V ±0.3V or VDD = VDDQ = 2.5V ±0.2V or VDD = +2.5V ±0.2V, VDDQ = +1.8V ±0.15V

Parameter/Condition	Symbol	Max			Units	Notes	
		-75M	-8	-10			
Operating current: Active mode; Burst = 2; READ or WRITE; $t_{RC} = t_{RC}(\text{MIN})$	IDD1	150	150	120	mA	18, 19	
Standby current: Power-down mode; All banks idle; CKE = LOW	IDD2	450	450	450	μA	12, 33	
Standby current: Active mode; CKE = HIGH; CS# = HIGH; All banks active after t_{RCD} met; No accesses in progress	IDD3	45	45	40	mA	19	
Operating current: Burst mode; Page burst; READ or WRITE; All banks active	IDD4	130	115	110	mA	18, 19	
Auto refresh current: CKE = HIGH; CS# = HIGH	$t_{RFC} = t_{RFC}(\text{MIN})$	IDD5	235	220	180	mA	12, 18, 19, 32, 33
	$t_{RFC} = 15.625\mu\text{s}$	IDD6	3	3	3	mA	
	$t_{RFC} = 3.906\mu\text{s(AT)}$	IDD6	6	6	6	mA	

Table 22: IDD7 Self Refresh Current Options (x32)

Note 4 applies to entire table; notes appear on page 57; VDD = VDDQ = +3.3V ±0.3V or VDD = VDDQ = 2.5V ±0.2V or VDD = +2.5V ±0.2V, VDDQ = +1.8V ±0.15V

Temperature-Compensated Self Refresh (TCSR) Parameter/Condition	Max Temperature	-75M/-8/-10	Units
Self refresh current: CKE < 0.2V (E4 = 1, E3 = 1)	85°C	1000	μA
Self refresh current: CKE < 0.2V (E4 = 0, E3 = 0)	70°C	550	μA
Self refresh current: CKE < 0.2V (E4 = 0, E3 = 1)	45°C	400	μA
Self refresh current: CKE < 0.2V (E4 = 1, E3 = 0)	15°C	350	μA

Table 23: Capacitance (FBGA Package)

Note 2 applies to entire table; notes appear on page 57

Parameter	Symbol	Min	Max	Units	Notes
Input capacitance: CLK	C11	1.5	3.5	pF	28
Input capacitance: All other input-only pins	C12	1.5	3.8	pF	29
Input/Output capacitance: DQ	C10	3.0	6.0	pF	30

Table 24: Capacitance (TSOP Package)

Note 2 applies to entire table; notes appear on page 57

Parameter	Symbol	Min	Max	Units	Notes
Input capacitance: CLK	C11	2.5	3.5	pF	28
Input capacitance: All other input-only pins	C12	2.5	3.8	pF	29
Input/Output capacitance: DQ	C10	4.0	6.0	pF	30

Notes

1. All voltages are referenced to Vss.
2. This parameter is sampled. VDD, VDDQ = +3.3V; $T_A = 25^\circ\text{C}$; pin under test biased at 1.4V, $f = 1\text{ MHz}$.
3. IDD is dependent on output loading and cycle rates. Specified values are obtained with minimum cycle time and the outputs open.
4. Enables on-chip refresh and address counters.
5. The minimum specifications are used only to indicate cycle time at which proper operation over the full temperature range is ensured ($0^\circ\text{C} \leq T_A \leq +70^\circ\text{C}$ (commercial), $-40^\circ\text{C} \leq T_A \leq +85^\circ\text{C}$ (industrial), and $-40^\circ\text{C} \leq T_A \leq +105^\circ\text{C}$ (automotive)).
6. An initial pause of 100 μs is required after power-up, followed by two AUTO REFRESH commands, before proper device operation is ensured. (VDD and VDDQ must be powered up simultaneously. VSS and VSSQ must be at same potential.) The two AUTO REFRESH command wake-ups should be repeated any time the t_{REF} refresh requirement is exceeded.
7. AC characteristics assume $t_{\text{T}} = 1\text{ ns}$.
8. In addition to meeting the transition rate specification, the clock and CKE must transit between VIH and VIL (or between VIL and VIH) in a monotonic manner.
9. Outputs measured at 1.5V (for LC devices) or at 1.25V (V devices) with equivalent load:

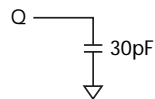

10. t_{HZ} defines the time at which the output achieves the open circuit condition; it is not a reference to VOH or VOL. The last valid data element will meet t_{OH} before going High-Z.
11. AC timing and IDD tests use established values for VIL and VIH, with timing referenced to VIH/2 crossover point. If the input transition time is longer than 1ns, then the timing is referenced at VIL(MAX) and VIH(MIN) and no longer at the VIH/2 crossover point. Established tester values follow: VIL = 0V, VIH = 3.0V for LC devices and VIH = 2.3V for V devices.
12. Other input signals are allowed to transition no more than once every 2 clocks and are otherwise at valid VIH or VIL levels.
13. IDD specifications are tested after the device is properly initialized.
14. Timing actually specified by t_{CKS} ; clock(s) specified as a reference only at minimum cycle rate.
15. Timing actually specified by t_{WR} plus t_{RP} ; clock(s) specified as a reference only at minimum cycle rate.
16. Timing actually specified by t_{WR} .
17. Required clocks are specified by JEDEC functionality and are not dependent on any timing parameter.
18. The IDD current will increase or decrease proportionally according to the amount of frequency alteration for the test condition.
19. Address transitions average one transition every 2 clocks.
20. CLK must be toggled a minimum of two times during this period.
21. Based on $t_{\text{CK}} = 125\text{MHz}$ for -8 and $t_{\text{CK}} = 100\text{MHz}$ for -10.

22. VIH overshoot: $V_{IH} (MAX) = V_{DDQ} + 2V$ for a pulse width $\leq 3ns$, and the pulse width cannot be greater than one-third of the cycle rate. VIL undershoot: $V_{IL} (MIN) = -2V$ for a pulse width $\leq 3ns$ and cannot be greater than one-third of the cycle rate.
23. The clock frequency must remain constant (stable clock is defined as a signal cycling within timing constraints specified for the clock pin) during access or precharge states (READ, WRITE, including t_{WR} , and PRECHARGE commands). CKE may be used to reduce the data rate.
24. Auto precharge mode only. The precharge timing budget (t_{RP}) begins at 5.4ns for -8 after the first clock delay after the last WRITE is executed.
25. Manual precharge mode only.
26. JEDEC and PC100 specify 3 clocks.
27. Parameter guaranteed by design.
28. PC100 specifies a maximum of 4pF.
29. PC100 specifies a maximum of 5pF.
30. PC100 specifies a maximum of 6.5pF.
31. For -75M, CL = 3 and $t_{CK} = 7.5ns$; for -8, CL = 3 and $t_{CK} = 8ns$; for -10, CL = 3 and $t_{CK} = 10ns$.
32. CKE is HIGH during refresh command period $t_{RFC} (MIN)$ else CKE is LOW. The IDD6 limit is actually a nominal value and does not result in a fail value.
33. Specified with I/Os in steady state condition.

Timing Diagrams

Figure 38: Initialize and Load Mode Register

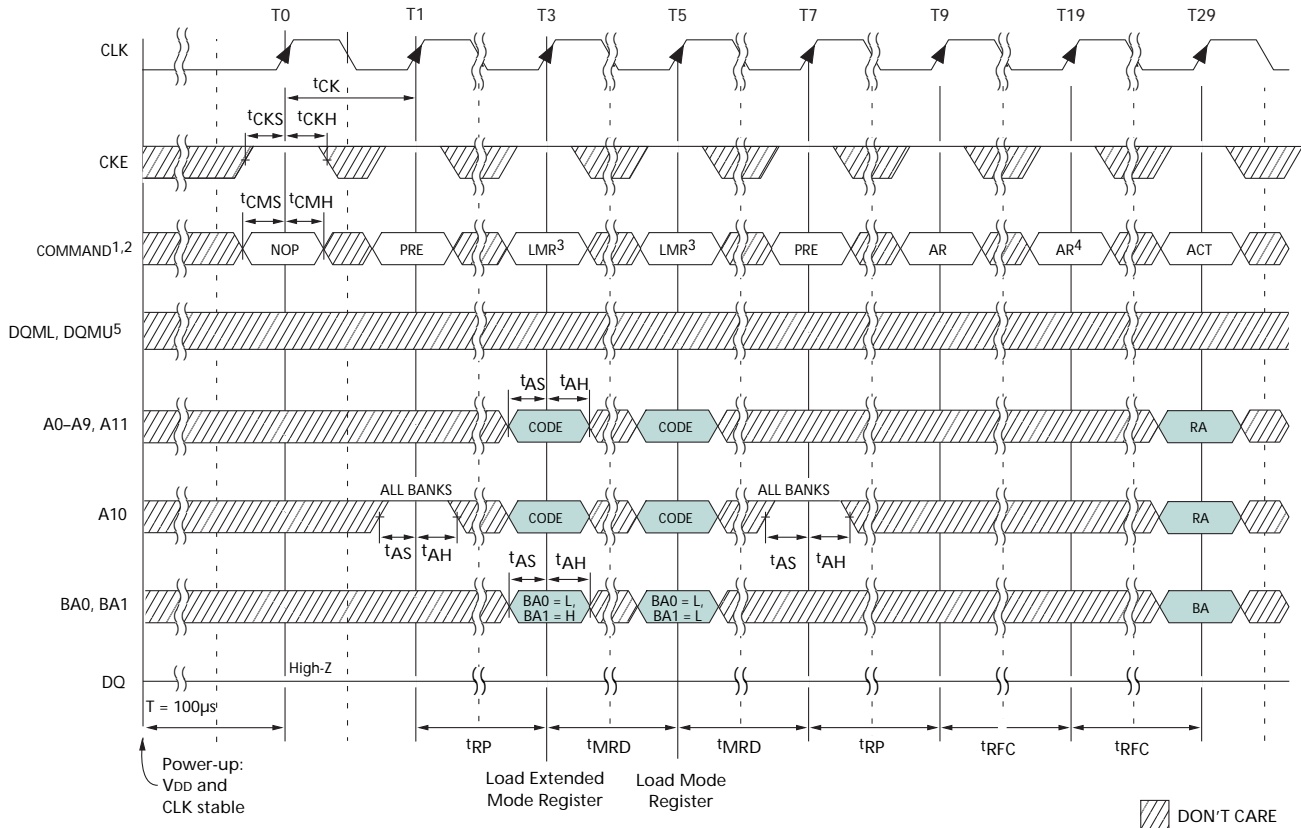

- Notes:
1. The two AUTO REFRESH commands at T9 and T19 may be applied either before LOAD MODE REGISTER (LMR) command.
 2. PRE = PRECHARGE command, LMR = LOAD MODE REGISTER command, AR = AUTO REFRESH command, ACT = ACTIVE command, RA = row address, and BA = bank address.
 3. The LOAD MODE REGISTER both for mode register and for extended mode register, and two AUTO REFRESH commands can be in any order. However, all must occur prior to an ACTIVE command.
 4. Optional REFRESH command.
 5. Although not required, to prevent bus contention, it is suggested to keep DQM HIGH during the initialization sequence. See Table 17 on page 53.

Figure 39: Power-down Mode

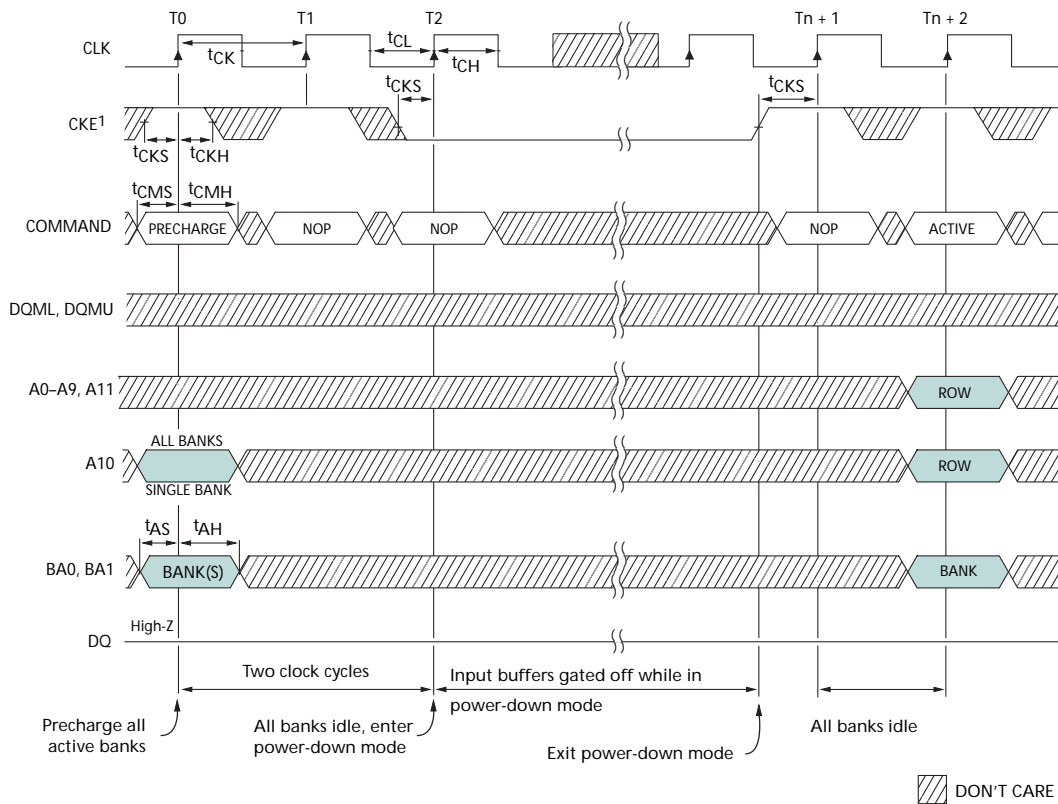

Notes: 1. Violating refresh requirements during power-down may result in a loss of data. See Table 17 on page 53.

Figure 40: Clock Suspend Mode

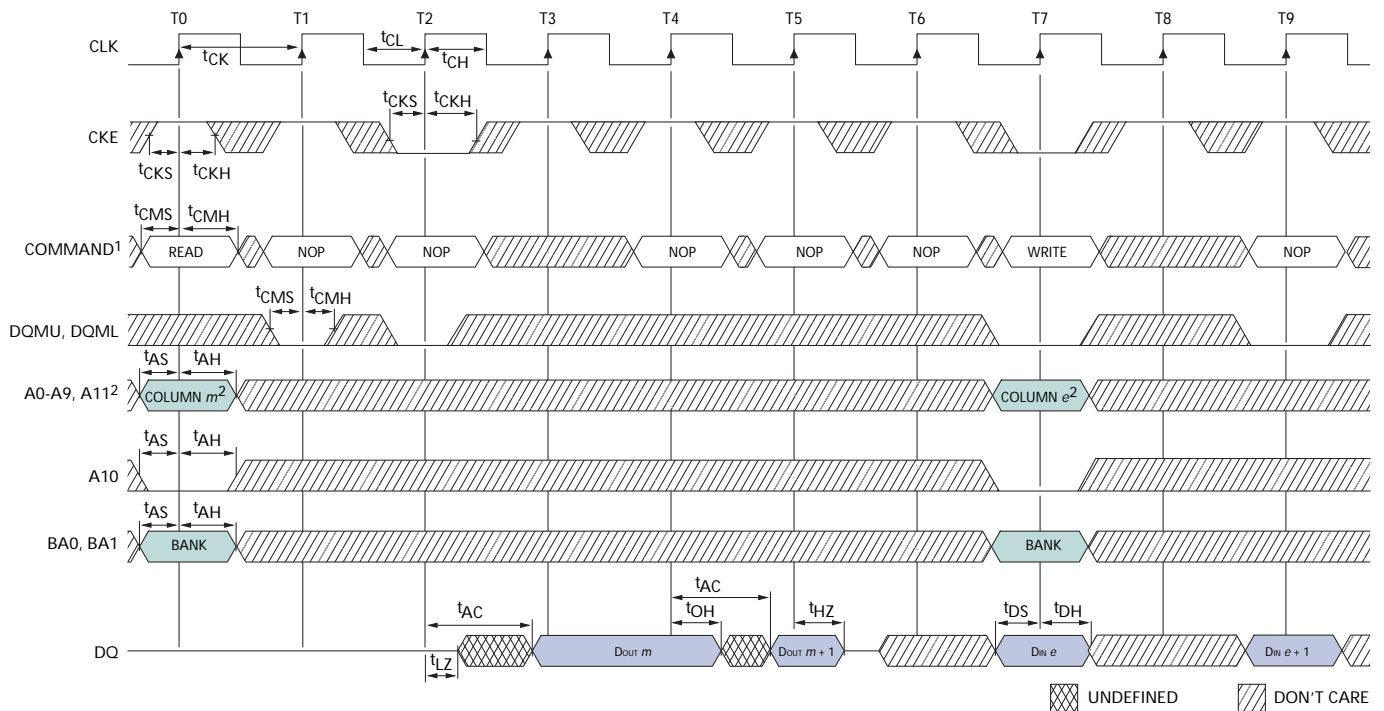

- Notes:
1. For this example, BL = 2, CL = 3, and auto precharge is disabled.
 2. x16: A9 and A11 = "Don't Care."
x32: A8, A9 and A11 = "Don't Care."
See Table 17 on page 53.

Figure 41: Auto Refresh Mode

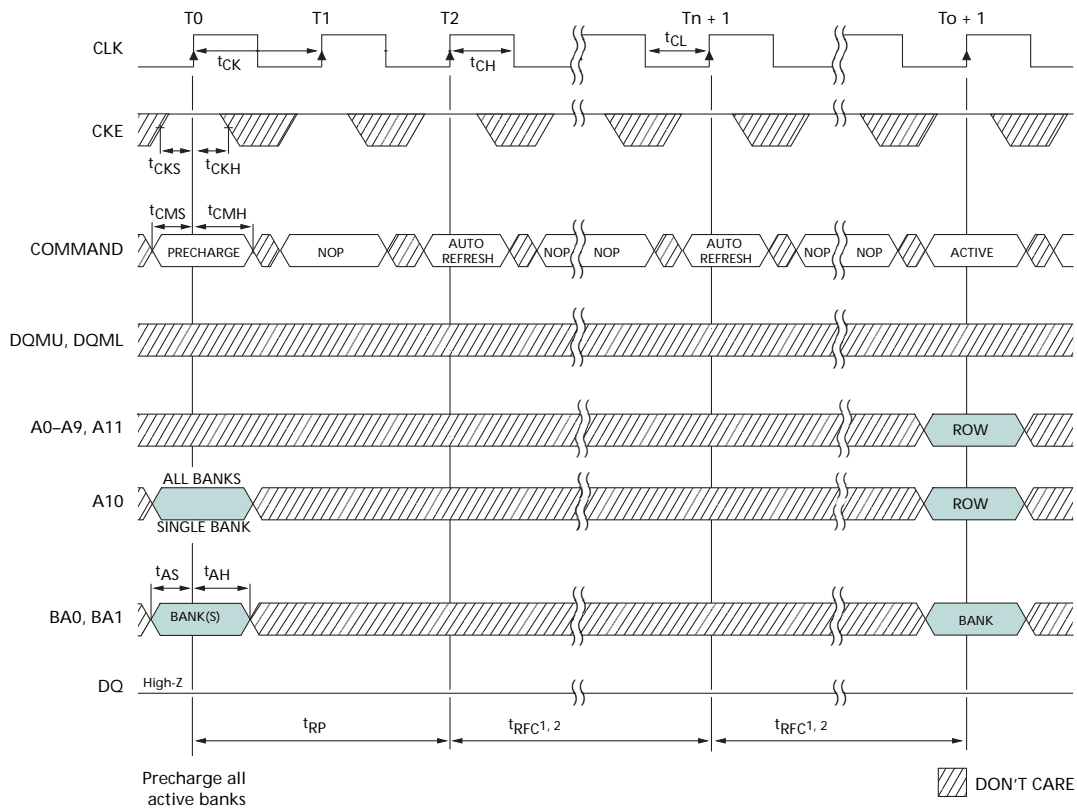

- Notes:
1. Each AUTO REFRESH command performs a refresh cycle. Back-to-back commands are not required. See Table 17 on page 53.
 2. t_{RFC} must not be interrupted by any executable command; COMMAND INHIBIT or NOP commands must be applied on each positive clock edge during t_{RFC} .

Figure 42: Self Refresh Mode

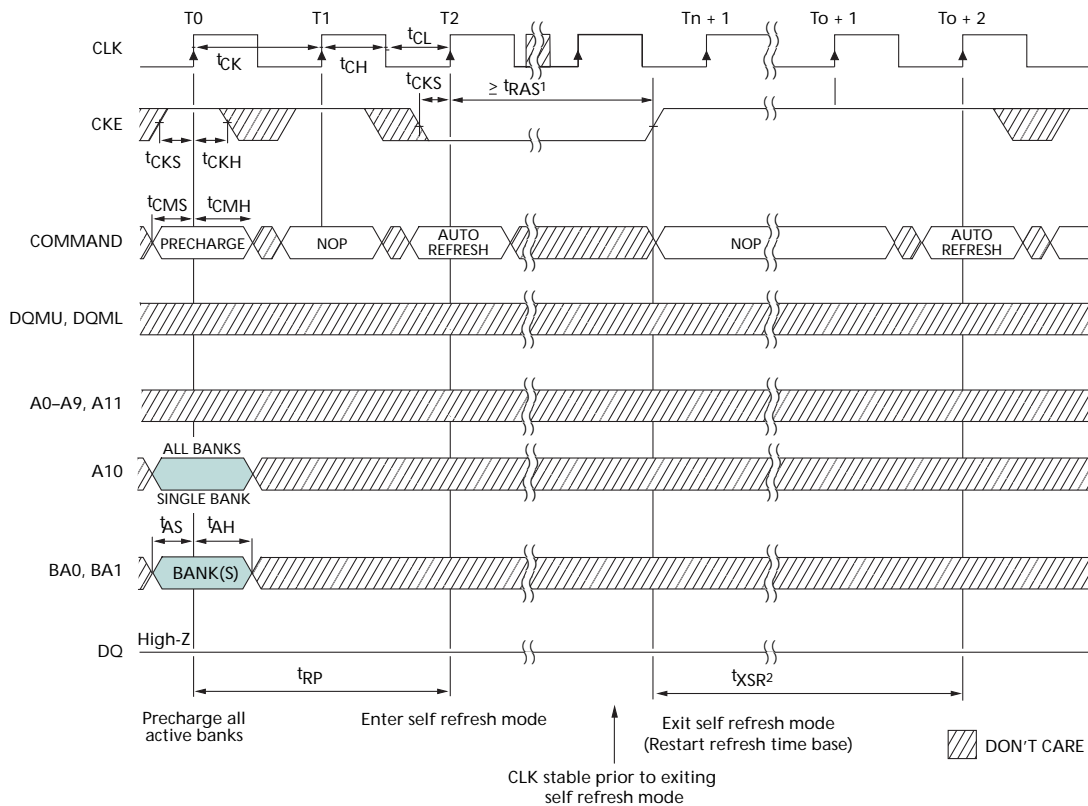

- Notes:
1. No maximum time limit for self refresh. $t_{RAS}^{(MAX)}$ only applies to non-self refresh mode.
 2. t_{XSR} requires a minimum of 2 clocks regardless of frequency or timing.
 3. As a general rule, any time self refresh is exited, the DRAM may not reenter the self refresh mode until all rows have been refreshed via the AUTO REFRESH command at the distributed refresh rate, ($t_{REF}/\text{number of rows}$), or faster. However, the following exception is allowed. Self refresh mode may be reentered any time after exiting if the following conditions are all met:
 - 3a. The DRAM has been in the self refresh mode for a minimum of 64ms prior to exiting.
 - 3b. t_{XSR} has not been violated.
 - 3c. At least two AUTO REFRESH commands are performed during each 15.625 μ s interval while the DRAM remains out of the self refresh mode. See Table 17 on page 53.
 4. Self refresh is not supported on automotive temperature (AT) devices.

Figure 43: READ – Without Auto Precharge

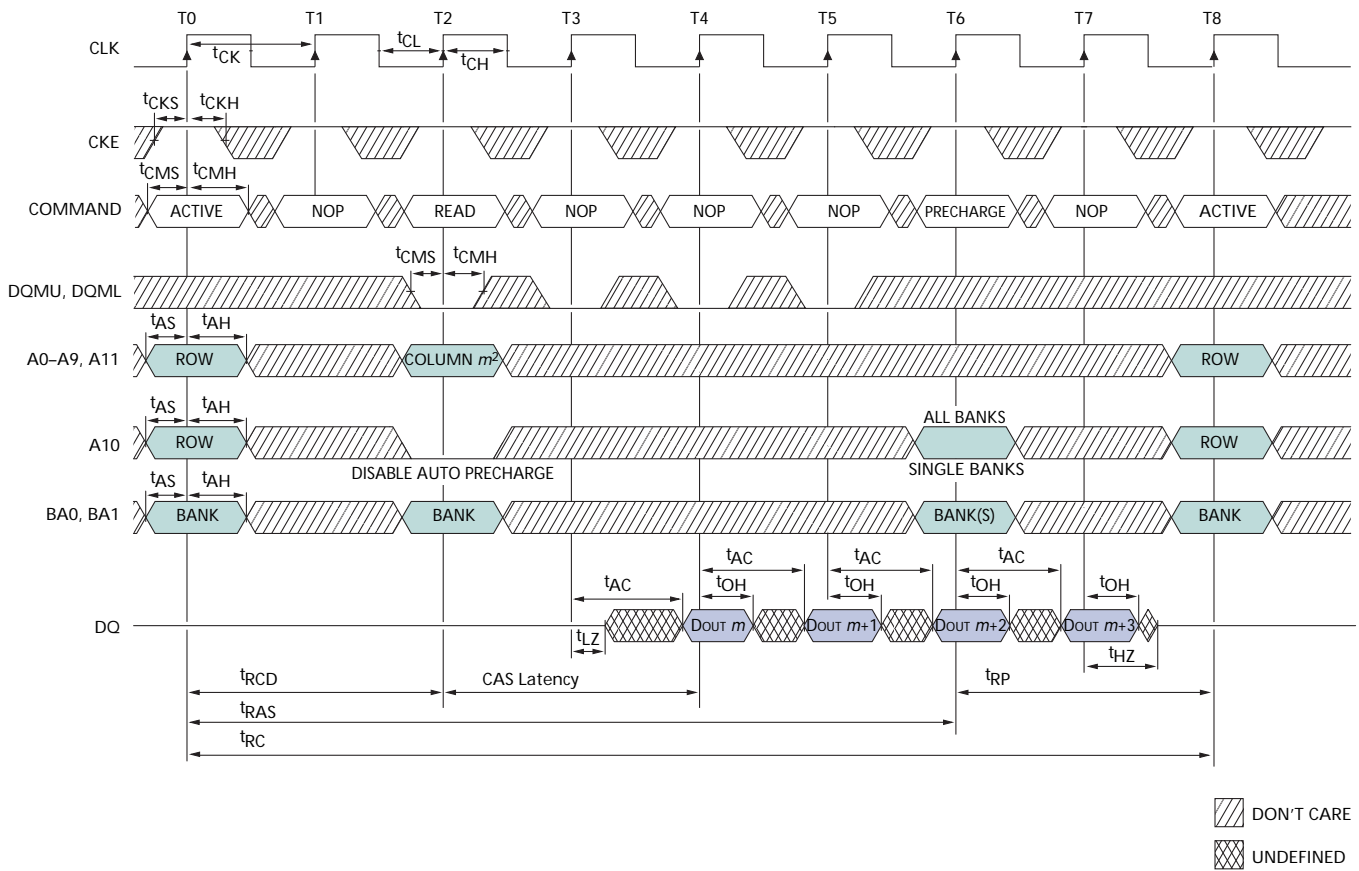

- Notes:
1. For this example, BL = 4, CL = 2, and the READ burst is followed by a “manual” PRECHARGE.
 2. x16: A9 and A11 = “Don’t Care.”
x32: A8, A9, and A11 = “Don’t Care.”
See Table 17 on page 53.

Figure 44: Read - With Auto Precharge

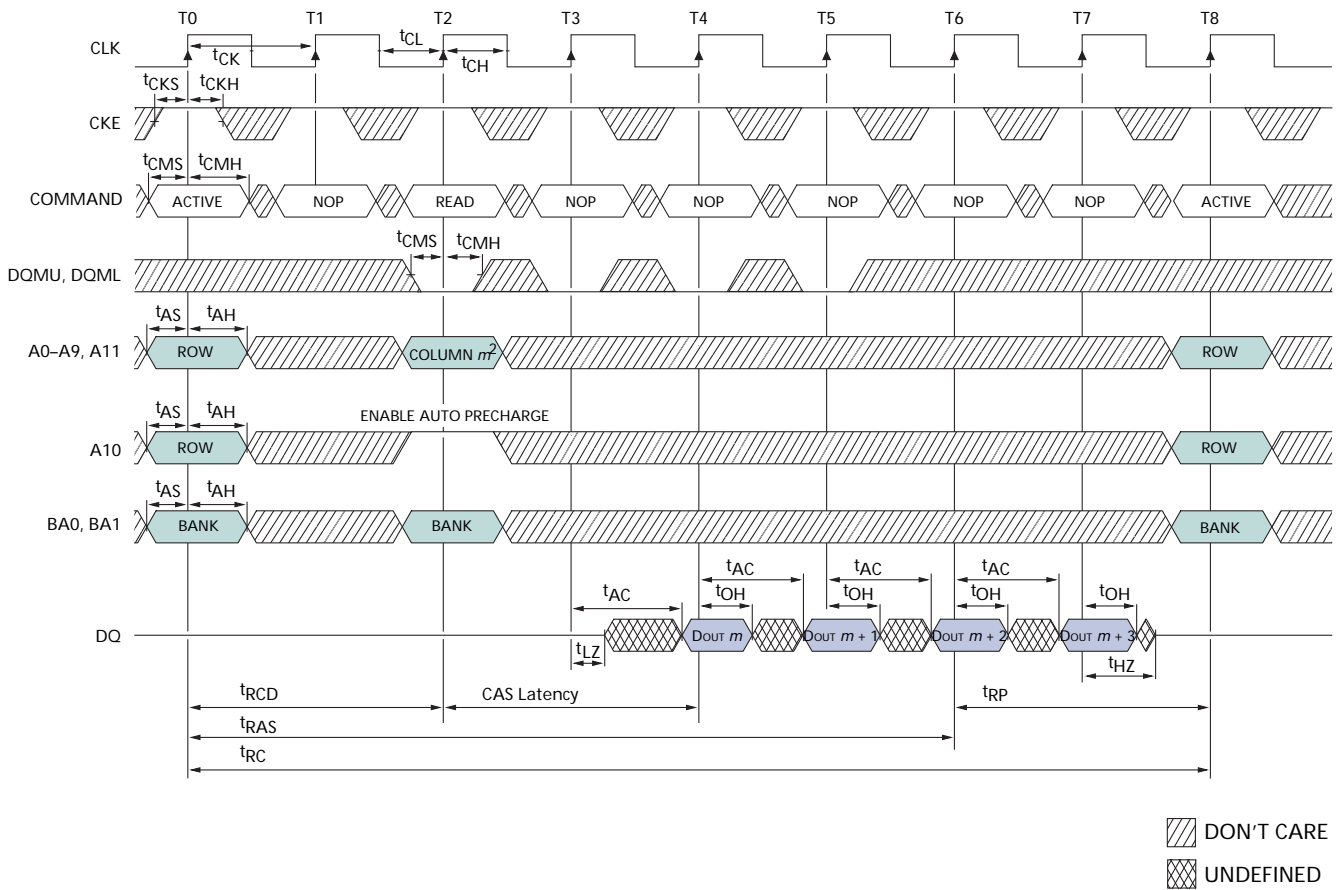

- Notes:
1. For this example, BL = 4 and CL = 2.
 2. x16: A9 and A11 = "Don't Care."
x32: A8, A9, and A11 = "Don't Care."
See Table 17 on page 53.

Figure 45: Single Read – Without Auto Precharge

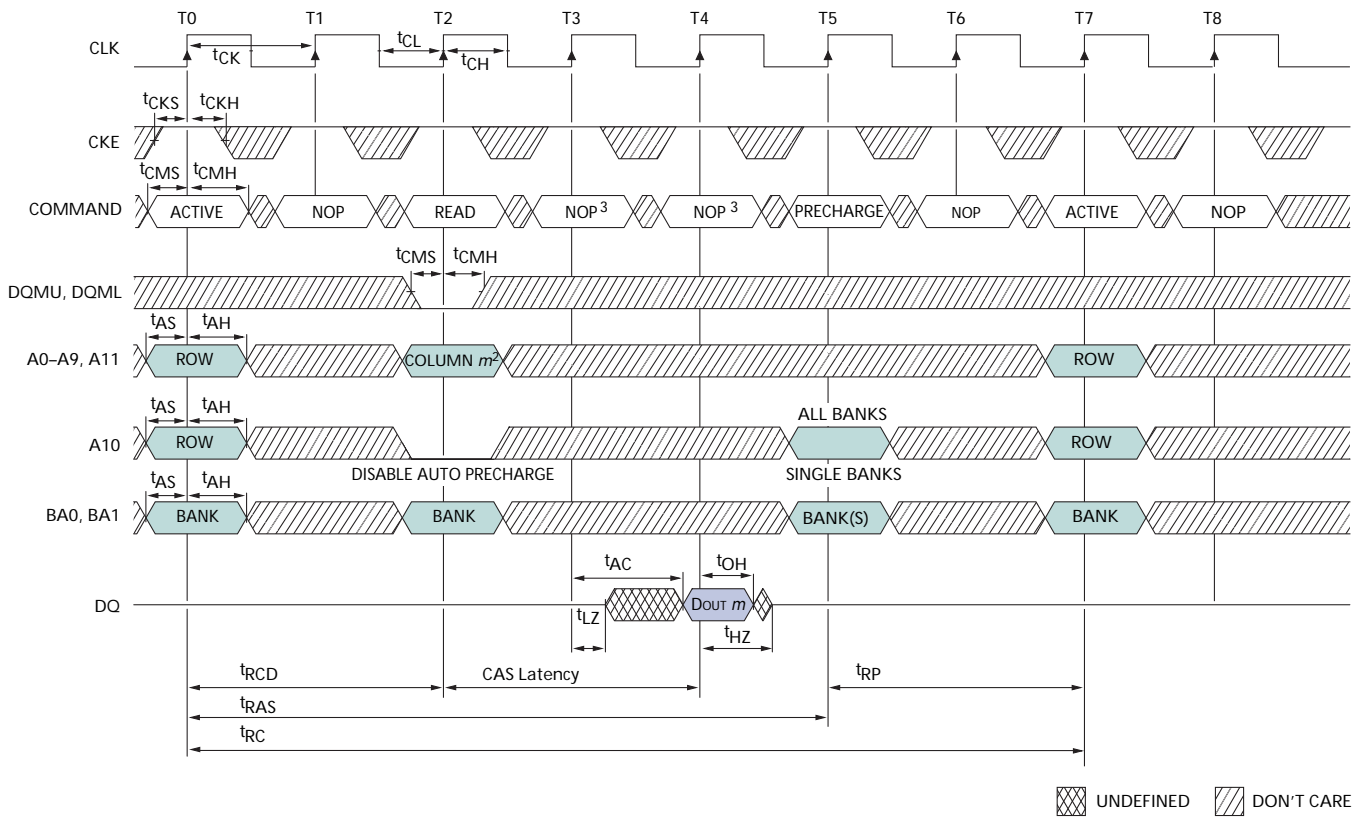

- Notes:
1. For this example, BL = 4, CL = 2, and the READ burst is followed by a “manual” PRECHARGE.
 2. x16: A9 and A11 = “Don’t Care.”
x32: A8, A9, and A11 = “Don’t Care.”
 3. PRECHARGE command not allowed or t_{RAS} would be violated.
See Table 17 on page 53.

Figure 46: Single Read – With Auto Precharge

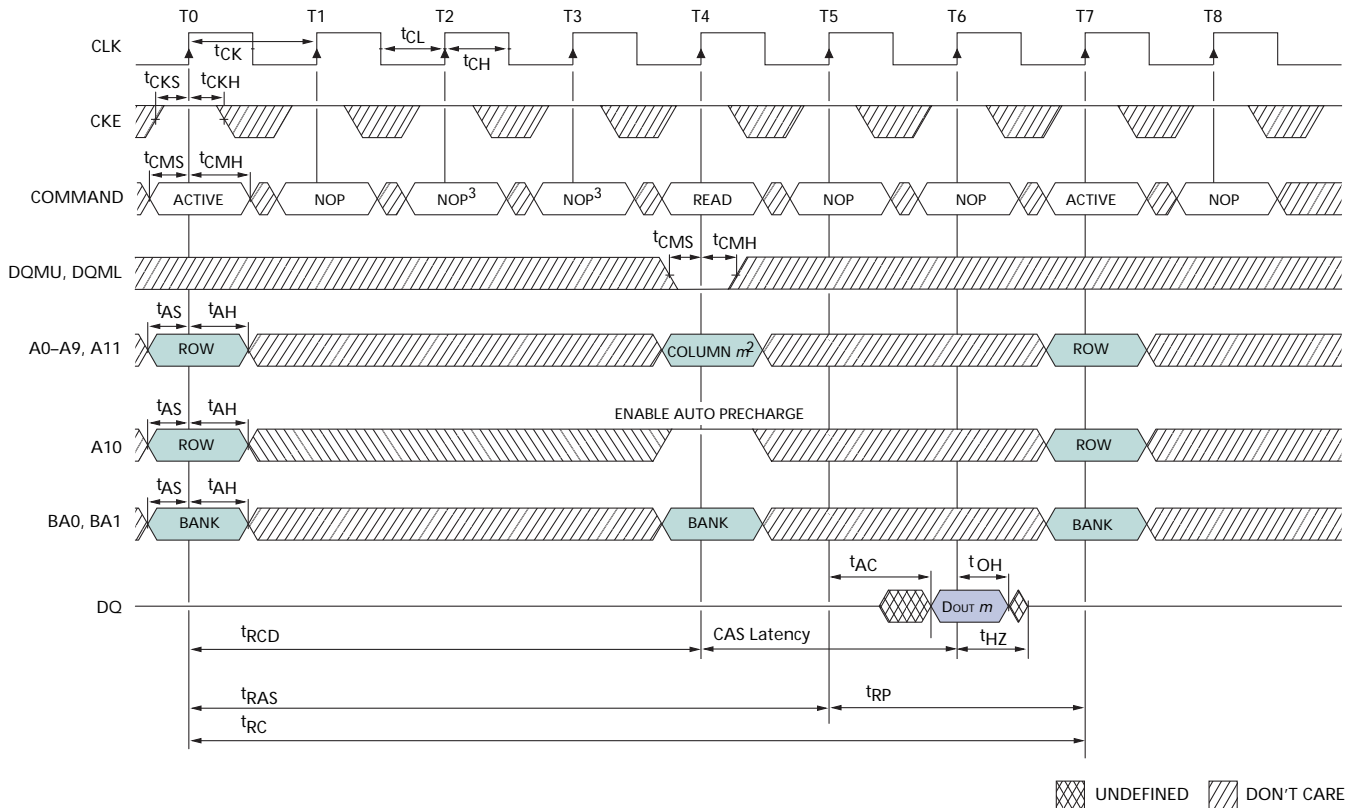

- Notes:
1. For this example, BL = 4, CL = 2, and the READ burst is followed by a “manual” PRECHARGE.
 2. x16: A9 and A11 = “Don’t Care.”
x32: A8, A9, and A11 = “Don’t Care.”
 3. PRECHARGE command not allowed or tRAS would be violated.
See Table 17 on page 53.

Figure 47: Alternating Bank Read Accesses

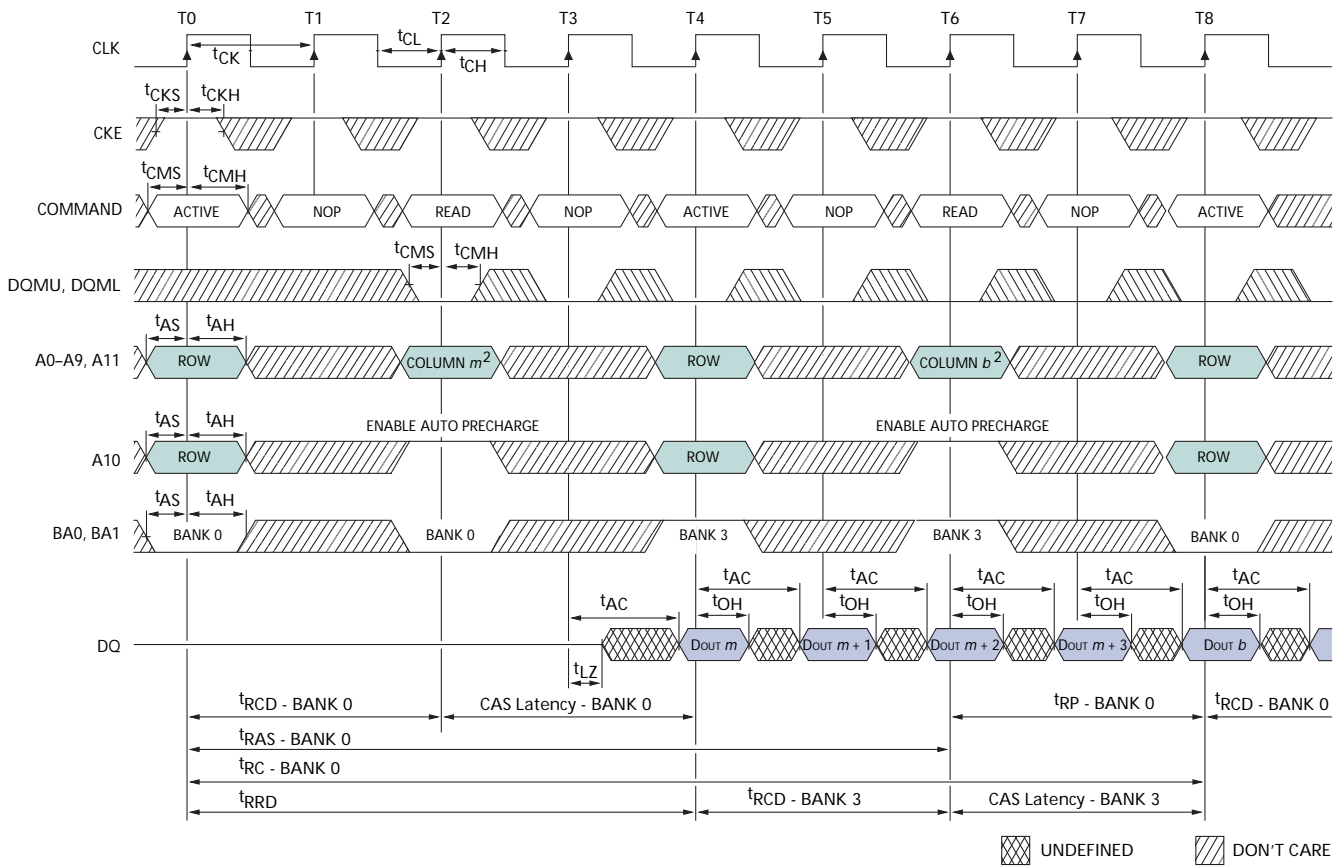

- Notes:
1. For this example, BL = 4 and CL = 2.
 2. x16: A9 and A11 = "Don't Care."
x32: A8, A9, and A11 = "Don't Care."
See Table 17 on page 53.

Figure 48: Read - Full-Page Burst

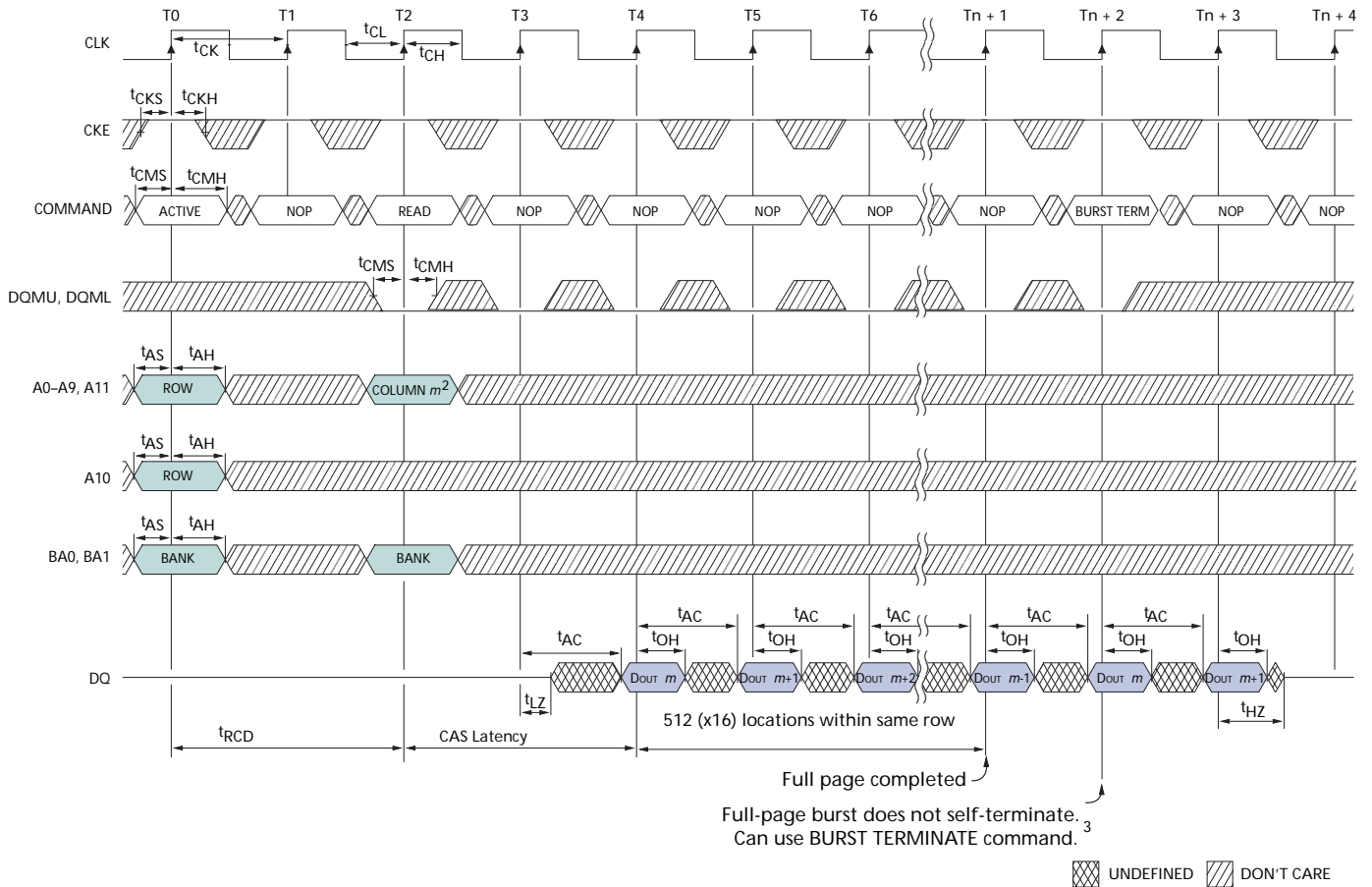

- Notes:
1. For this example, CL = 2.
 2. x16: A9 and A11 = "Don't Care."
x32: A8, A9, and A11 = "Don't Care."
 3. Page left open; no t_{RP} .
See Table 17 on page 53.

Figure 49: Read - DQM Operation

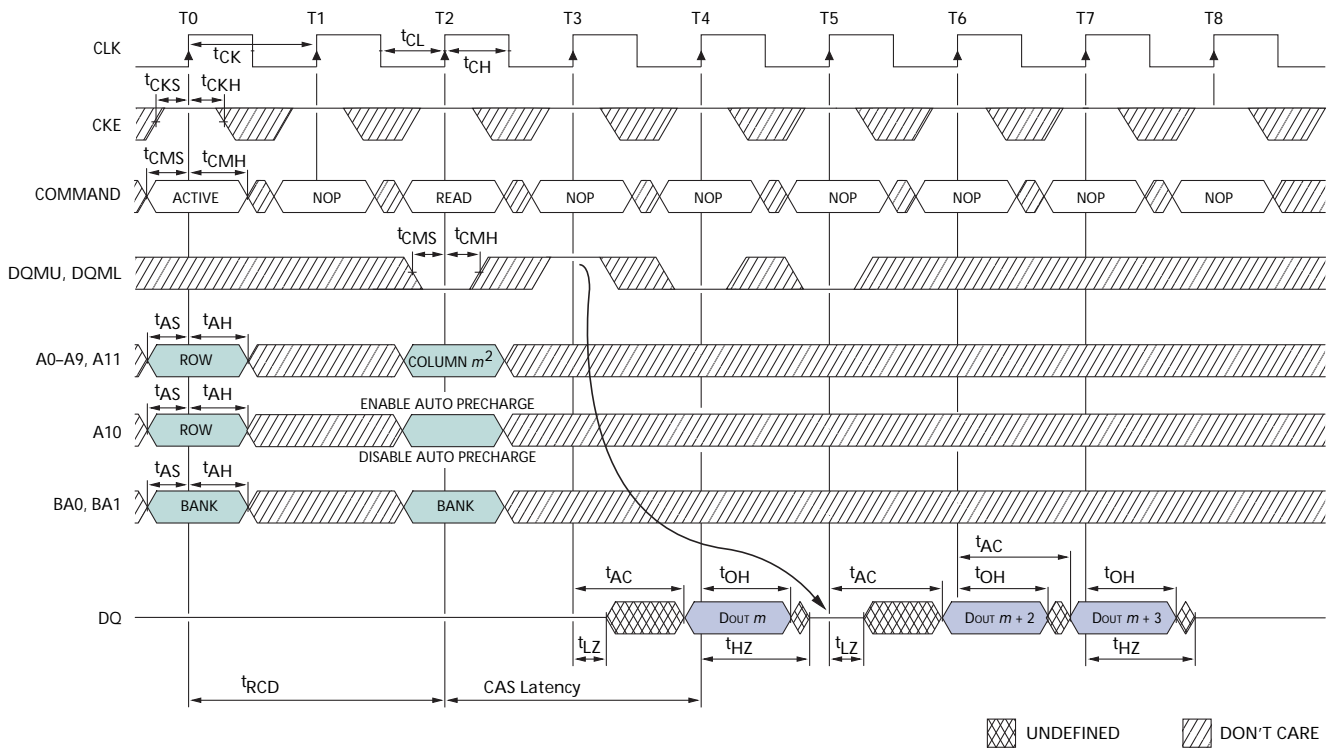

- Notes:
1. For this example, CL = 2.
 2. x16: A9 and A11 = "Don't Care."
x32: A8, A9, and A11 = "Don't Care."
See Table 17 on page 53.

Figure 50: Write – Without Auto Precharge

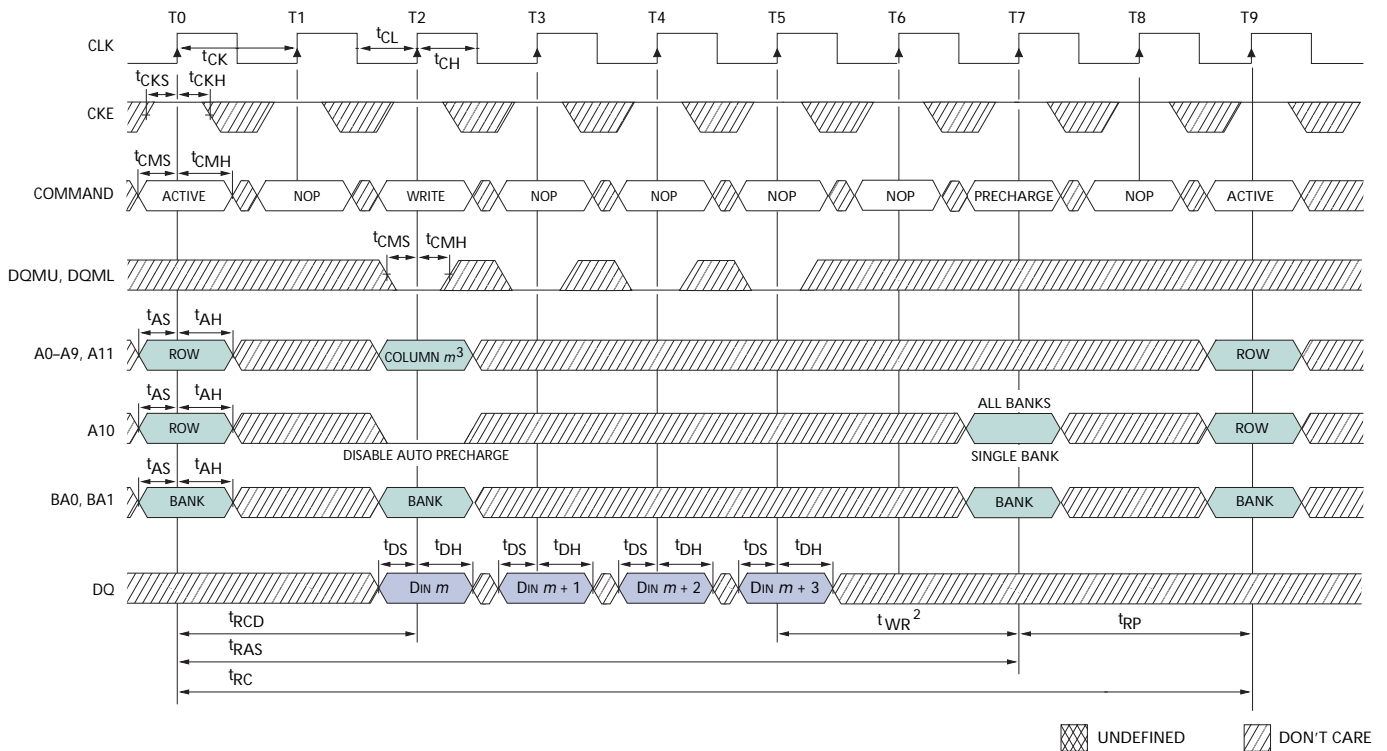

- Notes:
1. For this example, BL = 4, and the WRITE burst is followed by a “manual” PRECHARGE.
 2. 15ns is required between <DIN m + 3> and the PRECHARGE command regardless of frequency.
 3. x16: A9 and A11 = “Don’t Care.”
x32: A8, A9, and A11 = “Don’t Care.”
See Table 17 on page 53.

Figure 51: Write – With Auto Precharge

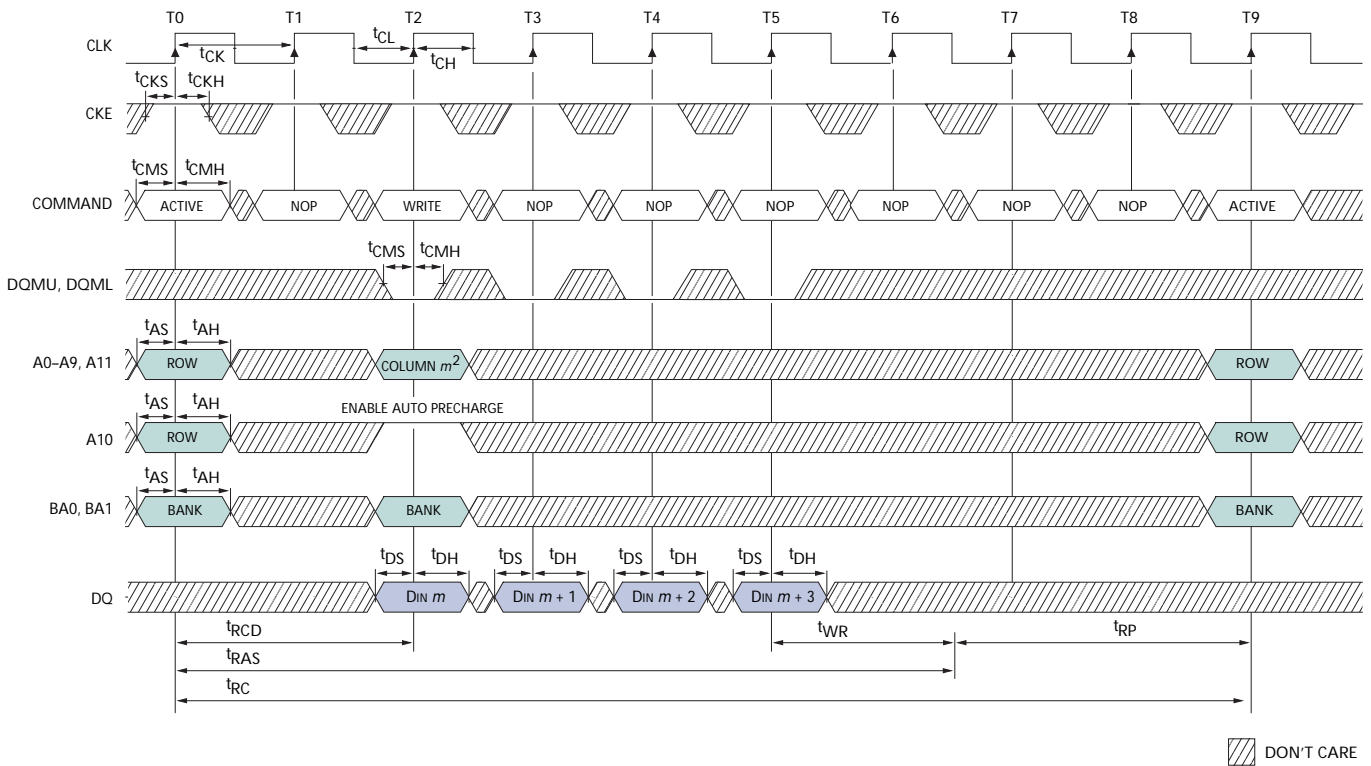

- Notes:
1. For this example, BL = 4.
 2. x16: A9 and A11 = "Don't Care."
x32: A8, A9, and A11 = "Don't Care."
See Table 17 on page 53.

Figure 52: Single Write – Without Auto Precharge

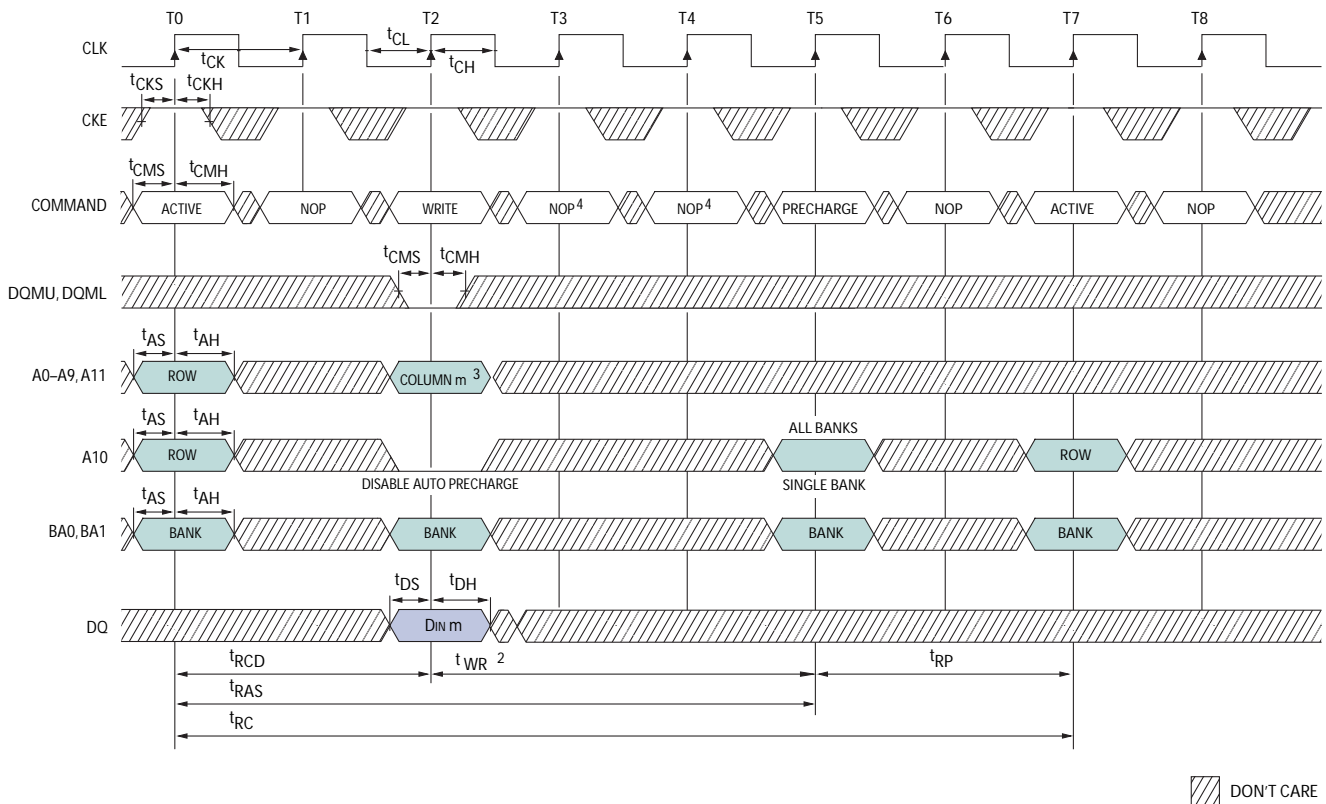

- Notes:
1. For this example, BL = 1, and the WRITE burst is followed by a “manual” PRECHARGE.
 2. 15ns is required between <DIN m> and the PRECHARGE command regardless of frequency.
 3. x16: A9 and A11 = “Don’t Care.”
x32: A8, A9, and A11 = “Don’t Care.”
 4. PRECHARGE command not allowed or t_{RAS} would be violated. See Table 17 on page 53.

Figure 53: Single Write – With Auto Precharge

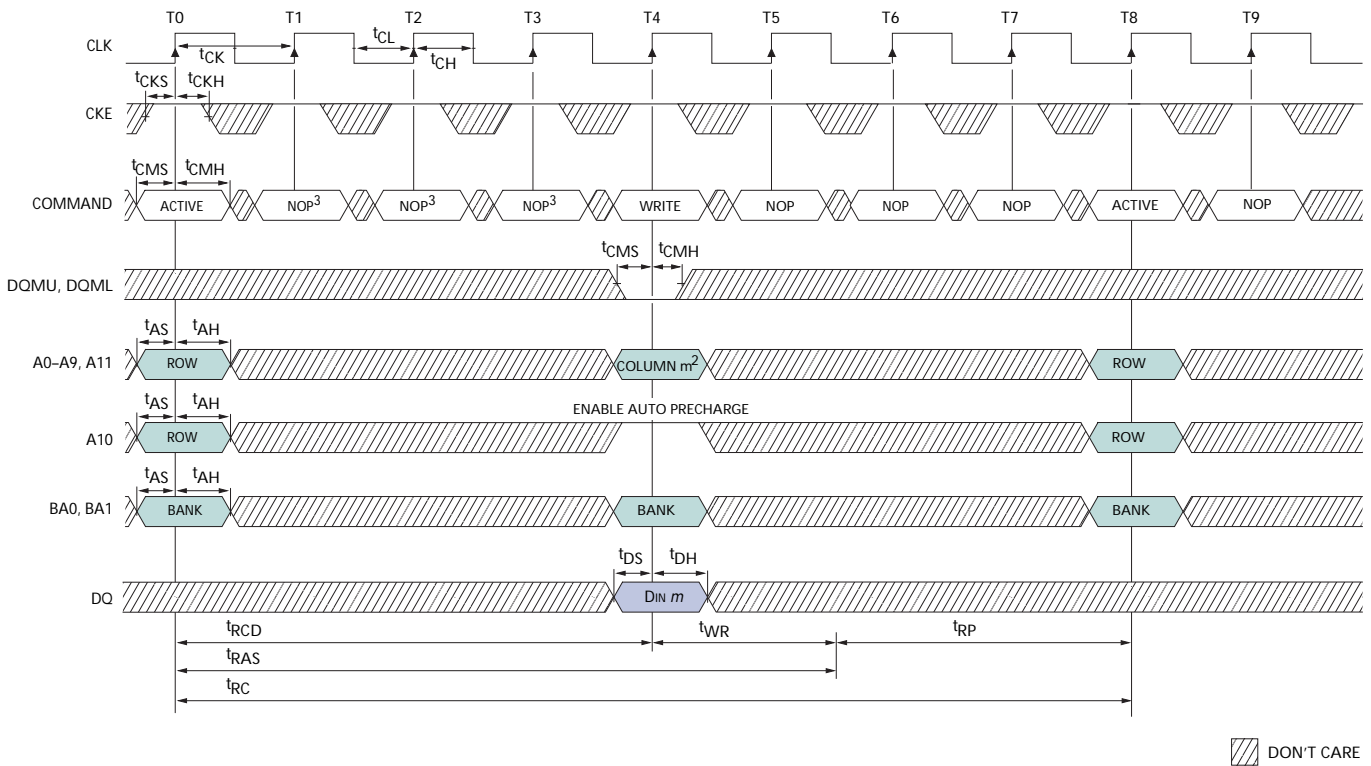

- Notes:
1. For this example, BL = 1, and the WRITE burst is followed by a "manual" PRECHARGE.
 2. 15ns is required between <DIN m> and the PRECHARGE command, regardless of frequency.
 3. x16: A9 and A11 = "Don't Care."
x32: A8, A9, and A11 = "Don't Care."
 4. WRITE command not allowed or t_{RAS} would be violated.
See Table 17 on page 53.

Figure 54: Alternating Bank Write Accesses

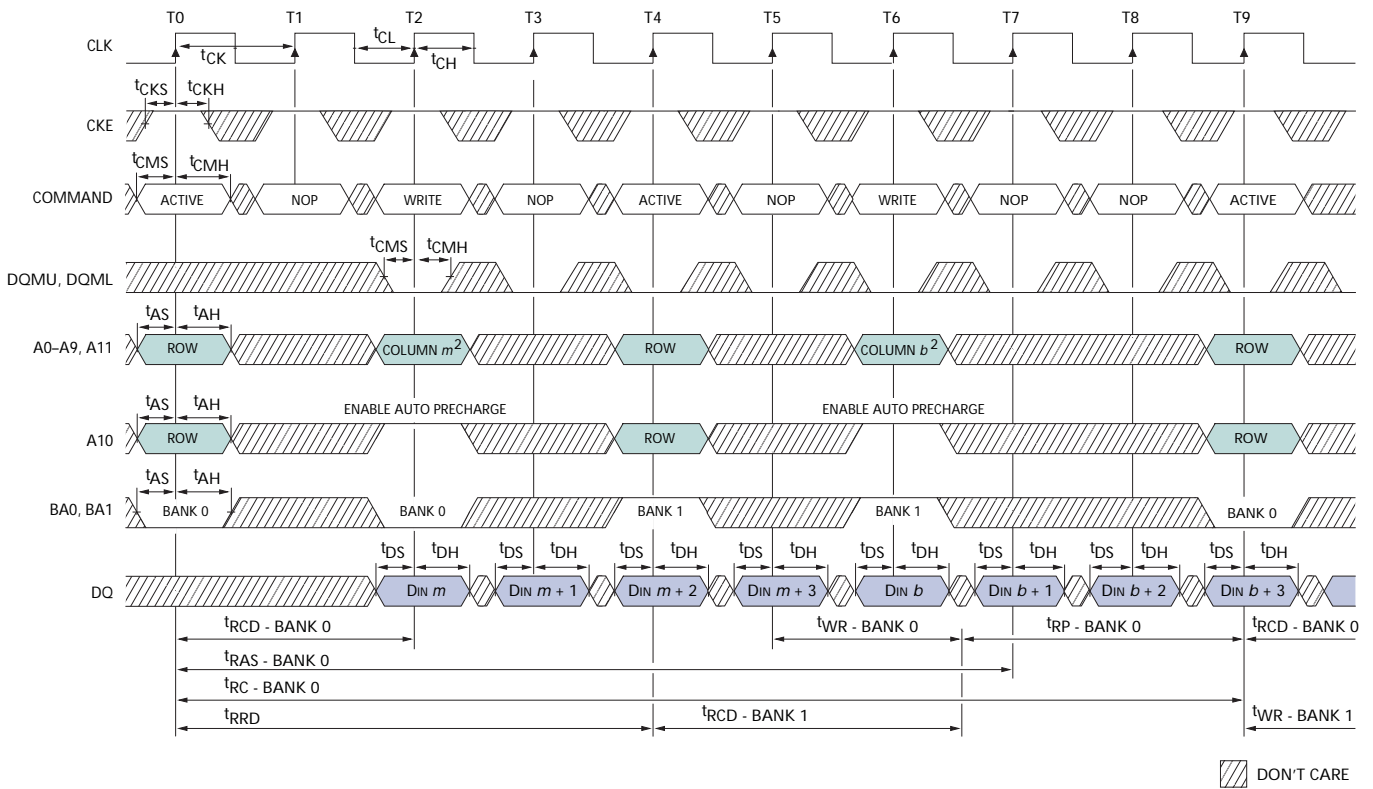

- Notes:
1. For this example, BL = 4.
 2. x16: A9 and A11 = "Don't Care."
x32: A8, A9, and A11 = "Don't Care."
See Table 17 on page 53.

Figure 55: Write – Full-page Burst

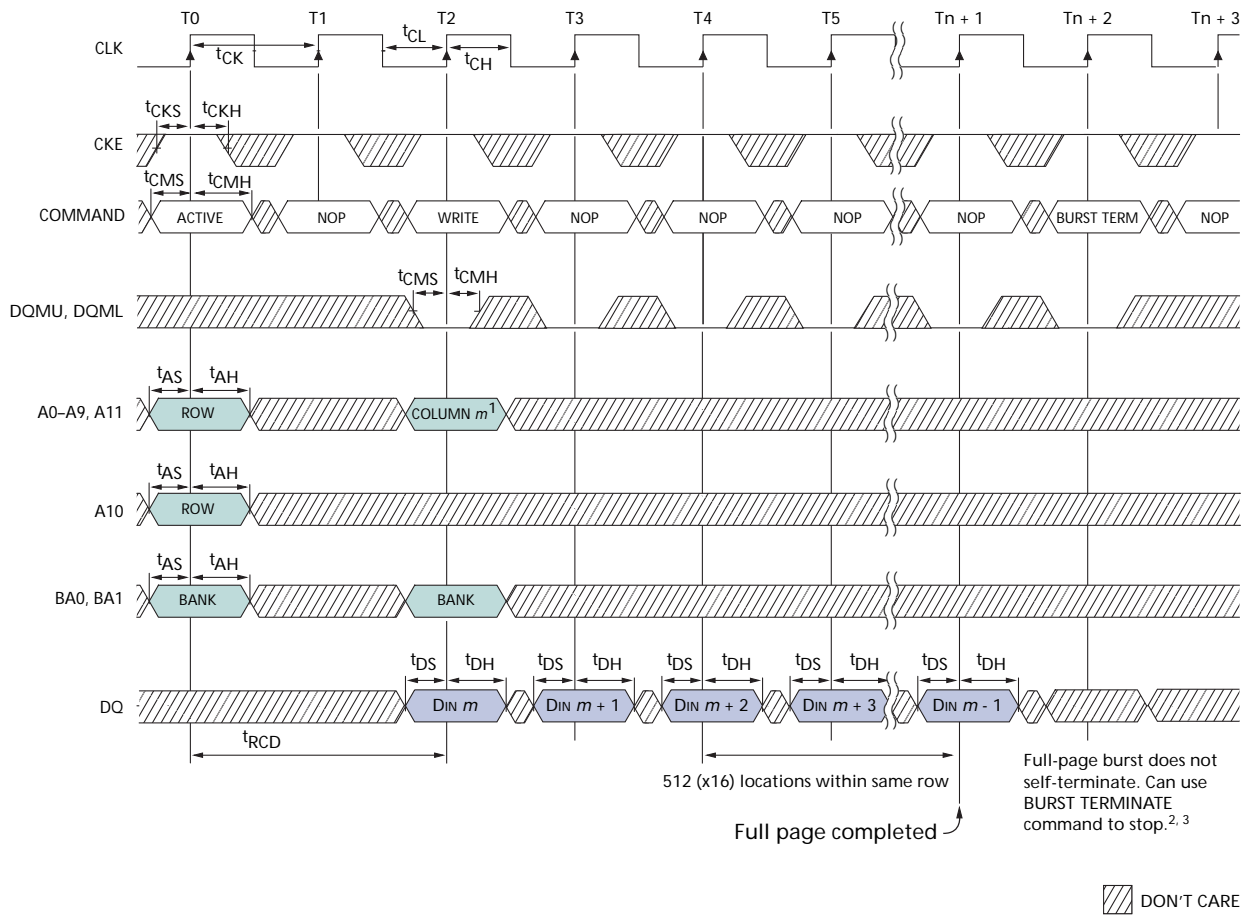

- Notes:
1. x16: A9 and A11 = "Don't Care."
x32: A8, A9, and A11 = "Don't Care."
 2. t_{WR} must be satisfied prior to PRECHARGE command.
 3. Page left open; no t_{RP} .
See Table 17 on page 53.

Figure 56: Write – DQM Operation

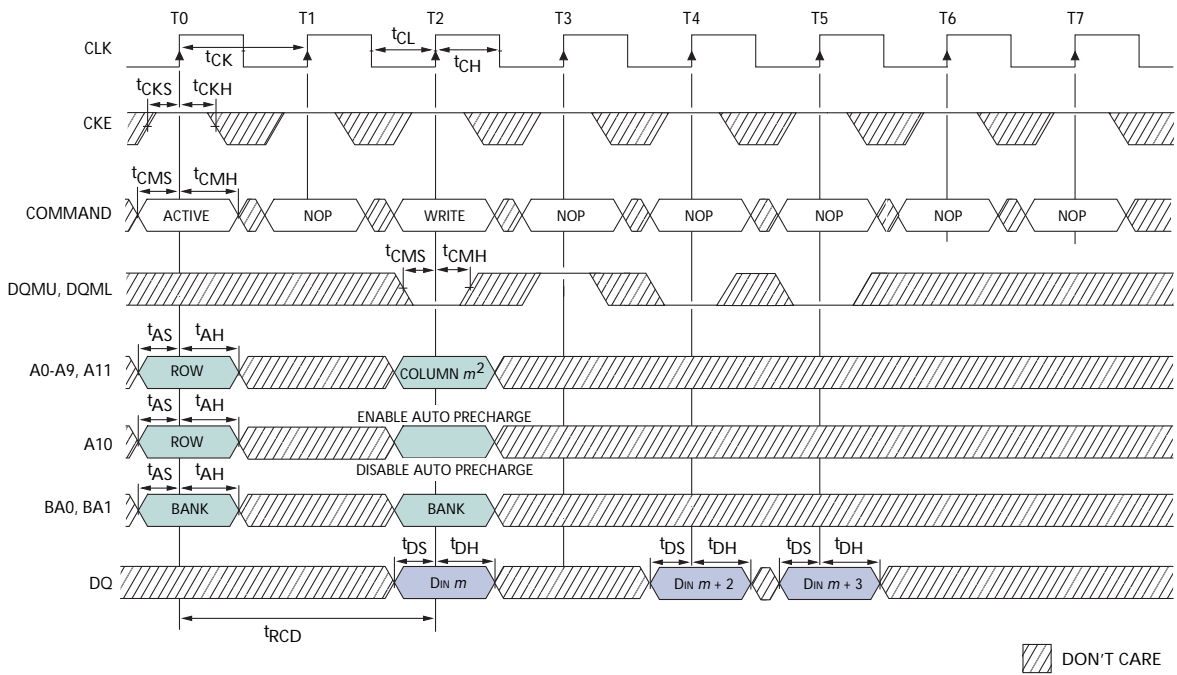

- Notes:
1. For this example, BL = 4.
 2. x16: A9 and A11 = "Don't Care."
x32: A8, A9, and A11 = "Don't Care."
See Table 17 on page 53.

Package Dimensions

Figure 57: 54-Ball FBGA, "F4/B4" Package (x16 Device), 8mm x 8mm

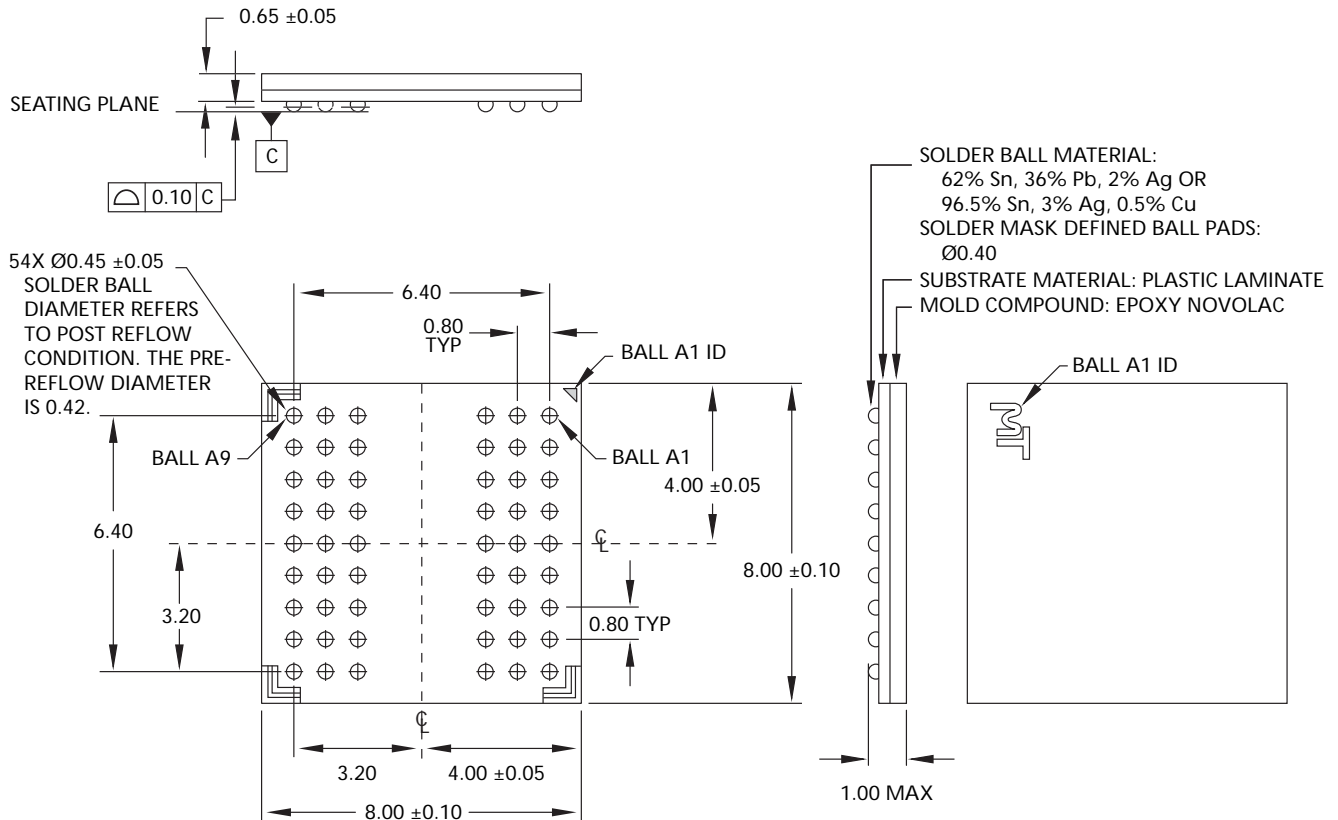

- Notes:
1. All dimensions are in millimeters.
 2. Recommended pad size for PCB is 0.40mm.
 3. Topside part marking decoder can be found at www.micron.com/decoder.

Figure 58: 90-Ball FBGA, "F5/B5" Package (x32 Device), 8mm x 13mm

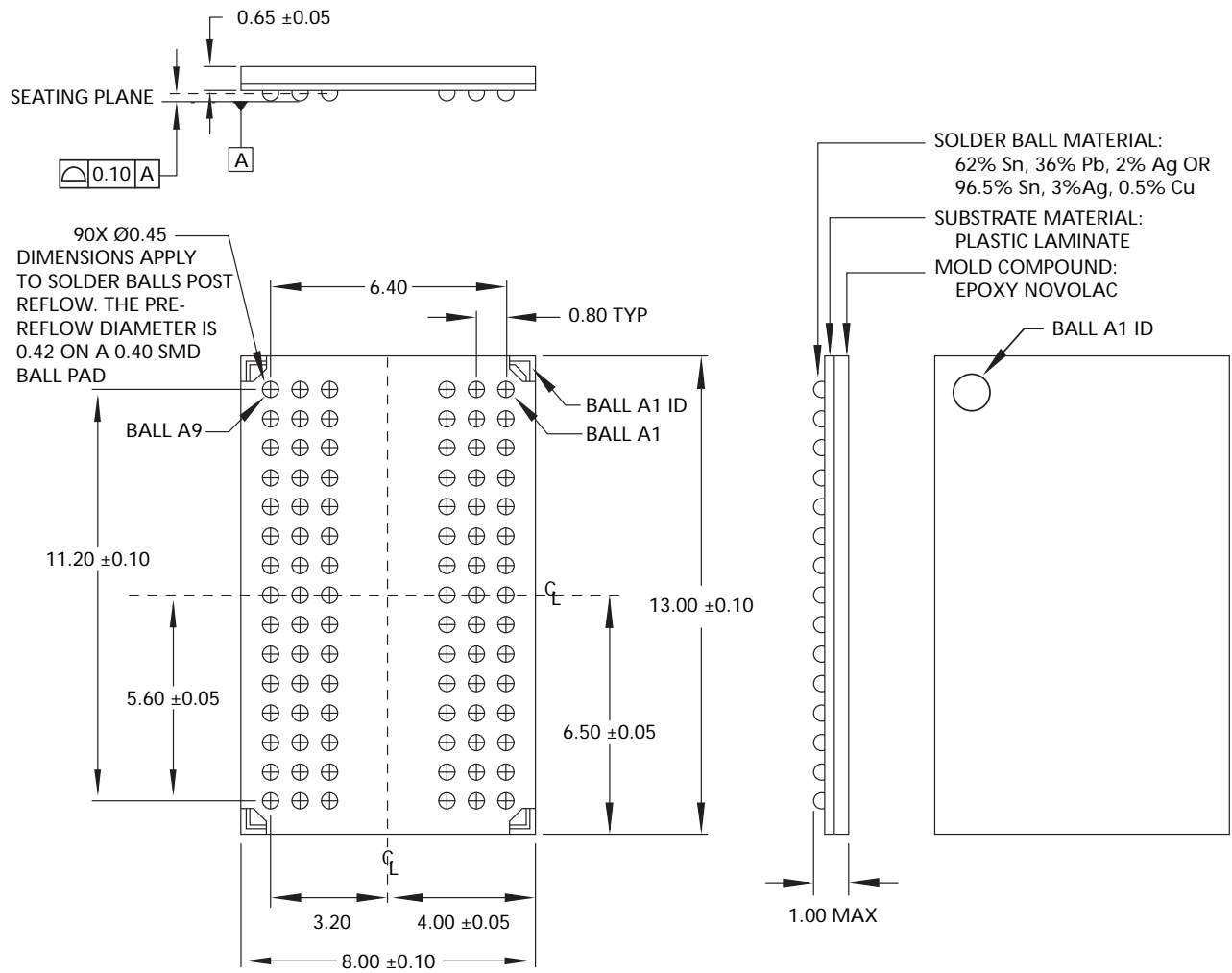

- Notes:
1. All dimensions are in millimeters.
 2. Recommended pad size for PCB is 0.4mm ±0.025mm.
 3. Package width and length do not include mold protrusion; allowable mold protrusion is 0.25mm per side.
 4. Topside part marking decoder can be found at www.micron.com/decoder.

Figure 59: 54-Pin Plastic TSOP (400 mil)

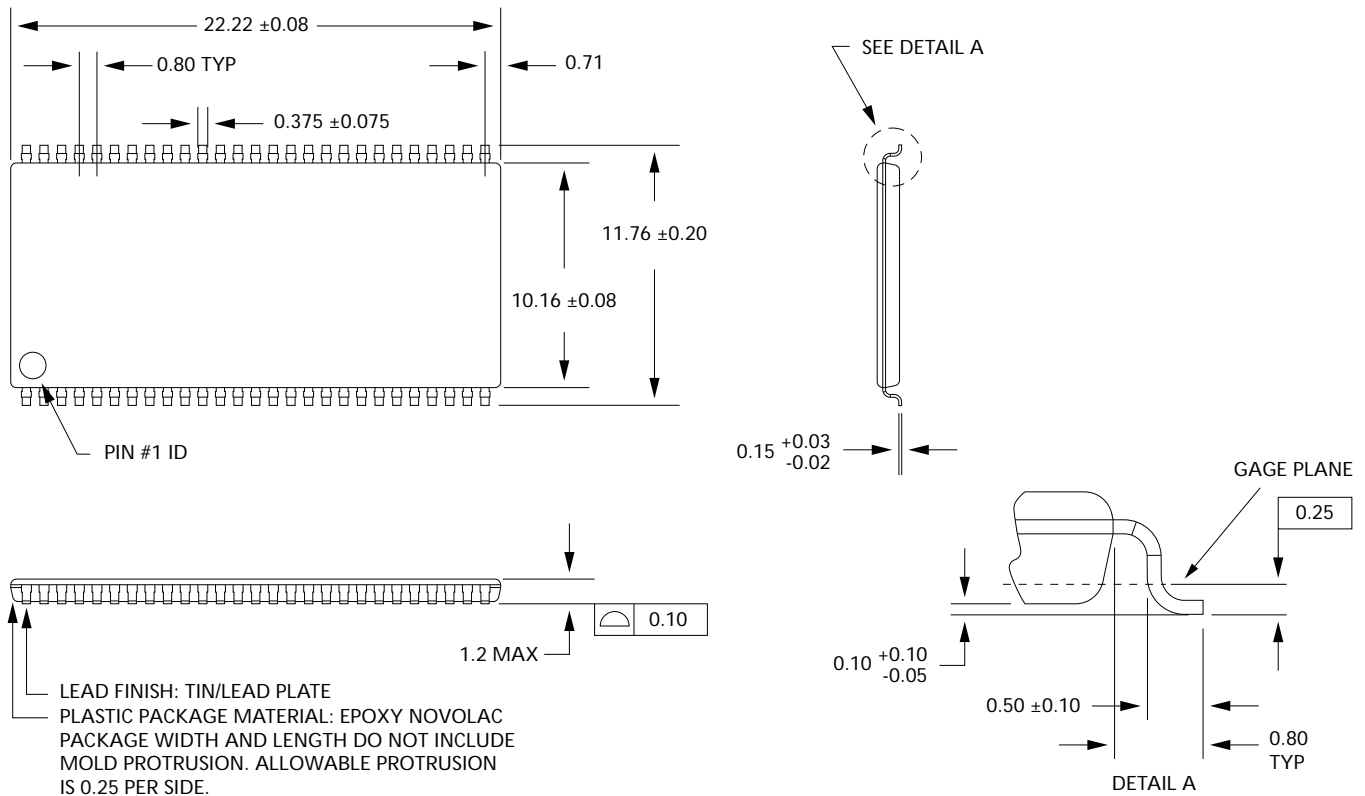

- Notes:
1. All dimensions are in millimeters.
 2. Package width and length do not include mold protrusion; allowable mold protrusion is 0.25mm per side.



8000 S. Federal Way, P.O. Box 6, Boise, ID 83707-0006, Tel: 208-368-3900

prodmktg@micron.com www.micron.com Customer Comment Line: 800-932-4992

Micron, the M logo, and the Micron logo are trademarks of Micron Technology, Inc. All other trademarks are the property of their respective owners.

This data sheet contains minimum and maximum limits specified over the power supply and temperature range set forth herein. Although considered final, these specifications are subject to change, as further product development and data characterization sometimes occur.

Looking for pricing, stock, or lifecycle information?

Click below to explore more details on WIN SOURCE:

- ⊖ [View MT48V4M32LFF5-8:G on WIN SOURCE](#)
- ⊖ [Micron Technology Inc. Information](#)

Optimize Your Supply Chain with WIN SOURCE Solutions

- ✓ Global Sourcing Solution
- ✓ Obsolete Management
- ✓ Cost Control Management
- ✓ Shortage Management
- ✓ Alternative Solution
- ✓ Excess Inventory Management