

Class-AB Speaker Amplifiers

1W+1W Stereo
Speaker / Headphone Amplifier

BH7884EFV

No.14077EBT06

●Description

The BH7884EFV is a low voltage, low noise, high output speaker and headphone amplifier drive, in which a Bi-CMOS process is used. This IC supports: headphone amplifier gain adjustment, active/suspend switching, speaker amplifier stereo/monaural switching, and amplifier mute switching. All functions are controllable from a microcontroller. Built-in digital noise reduction circuits eliminate digital noise and BEEP sounds.

●Features

- 1) Built-in 1W+1W stereo speaker amplifier ($V_{CC}=5V$, $R_L=8\Omega$, THD=10%)
- 2) Built-in stereo headphone amplifier
- 3) Built-in bass boost function for speaker amplifier
- 4) Built-in low noise VCA (electronic volume) for headphone
- 5) Built-in mute circuit
- 6) Built-in standby circuit
- 7) Low current consumption specifications (9 mA TYP. in ACTIVE mode, 0.2 μA TYP. in SUSPEND mode)

●Applications

Notebook computers, LCD TVs, etc.

●Absolute maximum ratings ($T_a=25^\circ C$)

Parameter	Ratings	Unit
Supply voltage	+6.0	V
Power dissipation	1100 *1	mW
Storage temperature	-55 ~ +125	$^\circ C$
Operating temperature	-10 ~ +70	$^\circ C$

*1 Reduced by 11 mW/ $^\circ C$ at $25^\circ C$ or higher, when mounting on a 70mmX70mmX1.6mm PCB board).

●Operating Conditions ($T_a=25^\circ C$)

Parameter	Ratings	Unit
Supply voltage	+3.0~+5.5	V

* This IC is not designed to be radiation-resistant.

● **Electrical characteristics** (Unless otherwise noted, $V_{CC}=3.3V$, $T_a=25^{\circ}C$, $f=1kHz$)

Parameter	Symbol	Limits			Unit	Condition
		Min.	Typ.	Max.		
■1 CHIP						
Circuit current ACTV	IA	-	9.0	18.0	mA	No signal ACTIVE
Circuit current SPND	Is	-	0.2	10.0	μA	No signal SUSPEND
■SP AMP						
Voltage gain1	G_{SP1}	9.0	12.0	15.0	dB	SE, $V_{in}=-18dBV, R_L=8\Omega$
Voltage gain2	G_{SP2}	15.2	18.2	21.2	dB	BTL, $V_{in}=-18dBV$
Distortion	D_{SP}	-	0.1	1.0	%	BTL, $V_{in}=-18dBV$
Maximum output level	V_{OSP}	2.2	5.2	-	dBV	BTL, DSP=1%
Output noise level	V_{NSP}	-	-97	-80	dBV	SE, DIN-Audio
Cross talk	CT_{SP}	-	-90	-80	dBV	SE, $V_{in}=-18dBV$, DIN-Audio
Output level on mute	MT_{SP}	-	-102	-80	dBV	BTL, $V_{in}=-18dBV$
■HP AMP						
Voltage gain 3	G_{HP}	2.6	5.6	8.6	dB	VOL:MAX, $R_L=10k\Omega, V_{in}=-12dBV$
Voltage gain 4	G_{HP}	-10	-7	-4	dB	VOL:MAX, $R_L=32\Omega, V_{in}=-12dBV$
Distortion	D_{HP}	-	0.025	0.1	%	VOL:MAX, $R_L=32\Omega, V_{in}=-8dBV$
Variable width of volume	ΔG_{HP}	70	100	-	dB	VOL:MIN ~ MAX, $R_L=32\Omega$
Maximum output level	V_{OHP}	-2.0	1.0	-	dBV	VOL:MAX, DHP=1%, $R_L=10k\Omega$
Output noise level	V_{NHP}	-	-98	-80	dBV	VOL:MAX, $R_L=32\Omega$, DIN-Audio
Cross talk	CT_{HP}	-	-98	-80	dBV	VOL:MAX, $R_L=32\Omega, V_{in}=-12dBV$ DIN-Audio
Output level on mute	MT_{HP}	-	-110	-80	dBV	VOL:MAX, $R_L=32\Omega, V_{in}=-12dBV$ DIN-Audio
■BEEP AMP						
Output voltage level	V_{BP}	0.8	1.25	-	Vpp	$V_{in}=1.3dBV, f=1kHz, 20MHzLFP$
■BIAS						
Output voltage level	V_{BIAS}	1.4	1.7	2.0	V	No Signal
■CTRL						
ACTIVE mode	V_{11H}	$V_{CC}-0.3$	-	V_{CC}	V	Active mode. Hold Voltage of 11pin.
SUSPEND mode	V_{11L}	GND	-	0.3	V	Suspend mode. Hold Voltage of 11pin.
SP/ON mode	V_{2H}	$V_{CC}-0.3$	-	V_{CC}	V	SP / ON mode. Hold Voltage of 2pin.
SP/OFF mode	V_{2L}	GND	-	0.3	V	SP/OFF mode. Hold Voltage of 2pin.
BASS-BOOST/ON mode	V_{4H}	$V_{CC}-0.7$	-	V_{CC}	V	SP / Bass Boost mode. Hold Voltage of 4pin.
BASS-BOOST/OFF mode	V_{4L}	GND	-	0.7	V	SP / Non Boost mode. Hold Voltage of 4pin.
STEREO mode	V_{3H}	$V_{CC}-0.7$	-	V_{CC}	V	SP / STEREO mode. Hold Voltage of 3pin.
MONO mode	V_{3L}	GND	-	0.7	V	SP / MONO mode. Hold Voltage of 3pin.
ACTIVE mode	V_{10H}	$V_{CC}-0.7$	-	V_{CC}	V	HP / Active mode. Hold Voltage of 10pin.
MUTE mode	V_{10L}	GND	-	0.7	V	HP / MUTE mode. Hold Voltage of 10pin.
■PSRR						
Ripple rejection ratio	G_{PR}	-	-64	-	dBV	$f=100Hz, 0.3V_{pp}$, SIN Input SPOUT monitor, DIN-Audio

●Block diagram

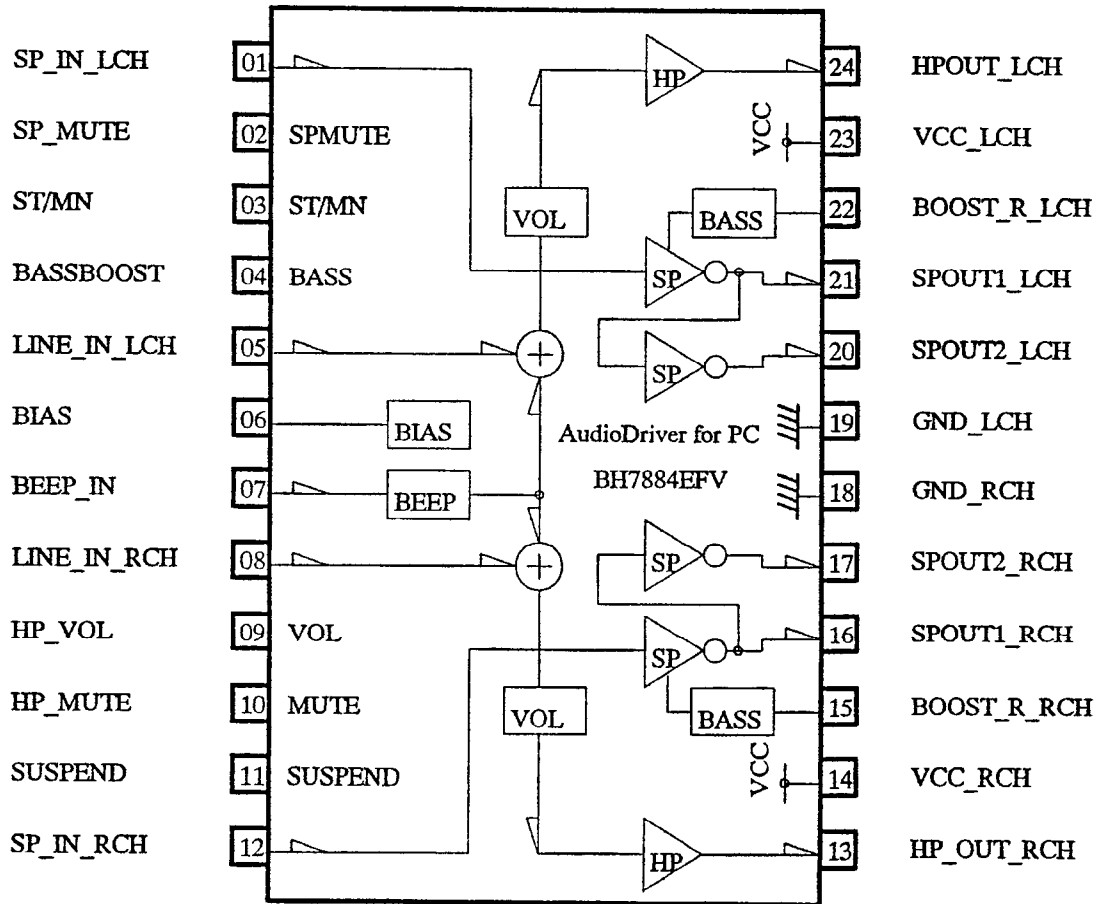

Fig.1

●Control pin settings

SP MUTE PIN:2PIN		
H	SP ACTIVE	SPAMP is in active state
L	SP MUTE	SPAMP is in suspend state
STEREO/MONO PIN:3PIN		
H	STEREO	For SPAMP, LCH and RCH both are in active state
L	MONO	For SPAMP, LCH is in active state and RCH is in suspend state
BASSBOOST PIN:4PIN		
H	BASS BOOST	For SPAMP, bass is boosted
L	NON -BOOST	For SPAMP, bass is not boosted
MUTE PIN:10PIN		
H	ACTIVE	HPAMP is in active state
L	MUTE	HPAMP is in mute state
SUSPEND PIN:11PIN		
H	ACTIVE	The IC is in active state
L	SUSPEND	The IC is in suspend state

●Equivalent circuit

PIN1	SP_IN_LCH	PIN2	SP_MUTE	PIN3	ST/MN	PIN4	BASS BOOST
PIN5	LINE_IN_LCH	PIN6	BIAS	PIN7	BEEP_IN	PIN8	LINE_IN_RCH
PIN9	HP_VOL	PIN10	HP_MUTE	PIN11	SUSPEND	PIN12	SP_IN_RCH

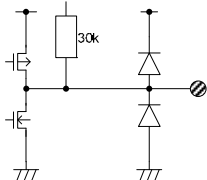
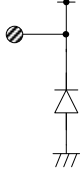
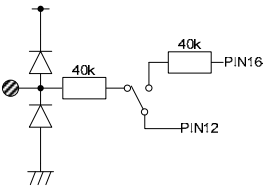
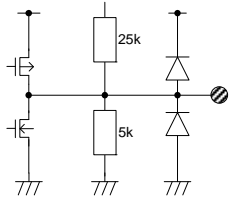
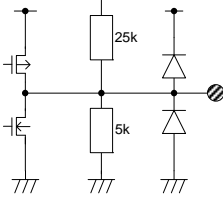
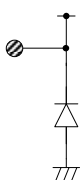
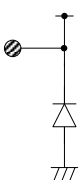
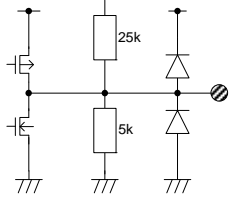
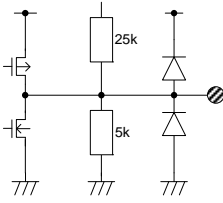
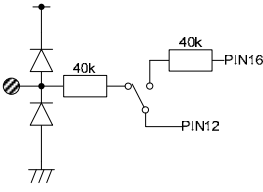
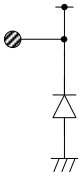
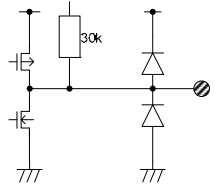
PIN13	HP_OUT_RCH	PIN14	VCC_RCH	PIN15	BOOST_R_RCH	PIN16	SPOUT1_RCH
							
PIN17	SPOUT2_RCH	PIN18	GND_RCH	PIN19	GND_LCH	PIN20	SPOUT2_LCH
							
PIN21	SPOUT1_LCH	PIN22	BOOST_R_LCH	PIN23	VCC_LCH	PIN24	HP_OUT_LCH
							

● Application circuit

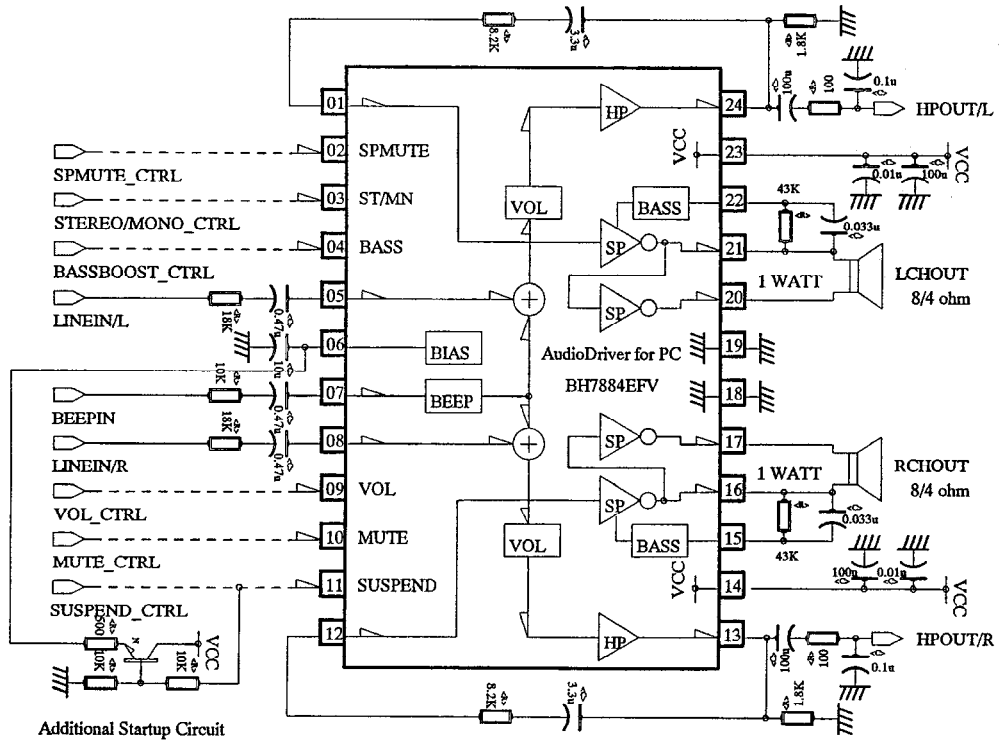

Fig.2

●Description of operations

1) LINEIN (5,8PIN) ~ HPOUT (13,24PIN) voltage gain

The voltage gain at EVRMAX is generally calculated by the following equation:

$$G_{HP} = 20 \times \log \frac{40k}{R_5(\text{or } R_8)} \quad (\text{dB})$$

The above gain attenuates according to the DC voltage of the VOL pin (9PIN).
By connecting multiple resistances (R), mixing input can be handled.

2) BEEPIN (7PIN) ~ HPOUT (13,24PIN)

When a pulse waveform is input at the BEEPIN pin, a pulse wave is output at HPOUT (24,13PIN).

The output level, determined by the resistance of 7PIN, has default values as follows:

HP OUT level	Vcc=5V	Vcc=4V	Vcc=3.3V
1Vpp<	<56k	<91k	<120k
0.5Vpp	68k	110k	160k
0.25Vpp	75k	130k	200k

*(Unit: Ω)

To obtain the default setting output (approx. 1.2 Vpp output), make R7=10 kΩ.

The variation in output levels is small.

Signals below a certain level are determined to be noise, by IC internals, and are not output at HPOUT.

3) SP IN (1,12PIN) ~ SP OUT (21, 20, 16,17PIN) voltage gain

The voltage gain in BASSBOOST is generally calculated by the following equation:

$$G_{SPB} = 20 \times \log \frac{40k + R_{21-20}(\text{or } R_{16-15})}{R_1(\text{or } R_{12})} \quad (\text{dB})$$

The cut-off frequency in BASSBOOST is generally calculated by the following equation:

$$f_{CB} = \frac{1}{2\pi C_{21-22}(\text{or } C_{16-15}) \times R_{21-20}(\text{or } R_{16-15})}$$

The voltage gain in NONBOOST is generally calculated by the following equation:

$$G_{SP} = 20 \times \log \frac{40k}{R_1(\text{or } R_{12})} \quad (\text{dB})$$

4) EVR control characteristic

HP AMP gain is controlled by the ratio of voltage to resistance between VCC and GND.

Note: A resistance (RN), shown above, is the resistance that is connected to pin N.

A capacitance (CN), shown above, is the capacitance that is connected to pin N.

The numeric values above are design reference values, whose values are not guaranteed.

● Operation Notes

1. Numbers and data in entries are representative design values and are not guaranteed values of the items.
2. Although ROHM is confident that the example application circuit reflects the best possible recommendations, be sure to verify circuit characteristics for your particular application. Modification of constants for other externally connected circuits may cause variations in both static and transient characteristics for external components as well as this Rohm IC. Allow for sufficient margins when determining circuit constants.
3. Absolute maximum ratings
Use of the IC in excess of absolute maximum ratings, such as the applied voltage or operating temperature range (Topr), may result in IC damage. Assumptions should not be made regarding the state of the IC (short mode or open mode) when such damage is suffered. A physical safety measure, such as a fuse, should be implemented when using the IC at times where the absolute maximum ratings may be exceeded.
4. GND potential
Ensure a minimum GND pin potential in all operating conditions. Make sure that no pins are at a voltage below the GND at any time, regardless of whether it is a transient signal or not.
5. Thermal design
Perform thermal design, in which there are adequate margins, by taking into account the permissible dissipation (Pd) in actual states of use.
6. Short circuit between terminals and erroneous mounting
Pay attention to the assembly direction of the ICs. Wrong mounting direction or shorts between terminals, GND, or other components on the circuits, can damage the IC.
7. Operation in strong electromagnetic field
Using the ICs in a strong electromagnetic field can cause operation malfunction.
8. Pop noise when switching power ON/OFF
To prevent pop noise when switching VCC ON/OFF or switching SUSPEND ON/OFF, use SUSPEND (11PIN=L), HP MUTE (10PIN=L), and SUSPEND (2PIN=L) for noise control, as shown below.

(VCC OFF→ON)

	VCC	SPND	HPMT	SPMT
1)	OFF	L	L	L
2)	ON	L	L	L
3)	ON	H	L	L
4)	ON	H	H	L
5)	ON	H	H	H

(VCC ON→OFF)

	VCC	SPND	HPMT	SPMT
1)	OFF	H	H	H
2)	ON	H	H	L
3)	ON	H	L	L
4)	ON	L	L	L
5)	ON	L	L	L

9. Power supply bypass capacitor
Place the bypass capacitor close to the VCC ~ GND pins.
10. Mode switching
Do not apply a voltage that exceeds VCC or a voltage that is less than GND, at a control pin.
11. Power package
Ensure heat dissipation by connecting the heatsink to the back of the IC and to the GND board. Ensure that the GND area is large.
12. HPOUT
Connect resistance (100 Ω is recommended) to the output for SPAMP input level adjustment and to prevent HPAMP oscillation.
13. Capacitive load
Do not connect a capacitive load to SPAMP or HPAMP output as it may cause oscillation.
14. Startup time at low temperature and reduced power
Use the following methods to eliminate longer start up time at low temperatures (less than about -10°C) and reduced power (less than about 3.0 V):
 - 1) Start in SPMUTE state and then cancel SPMUTE.
 - 2) Add to transistor and resistance, as shown in the application circuit diagram.

●Ordering part number

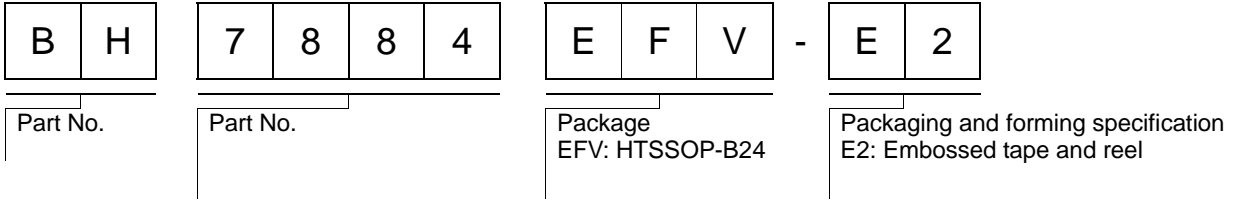

HTSSOP-B24

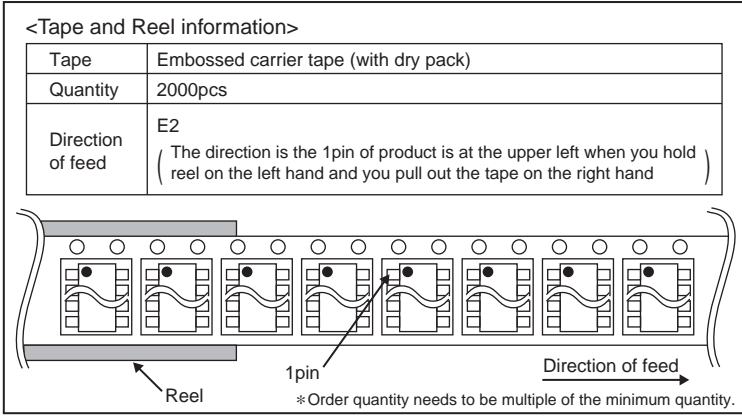
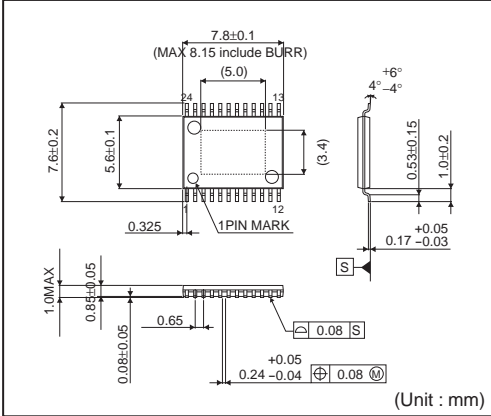

Notice

Precaution on using ROHM Products

- Our Products are designed and manufactured for application in ordinary electronic equipments (such as AV equipment, OA equipment, telecommunication equipment, home electronic appliances, amusement equipment, etc.). If you intend to use our Products in devices requiring extremely high reliability (such as medical equipment ^(Note 1), transport equipment, traffic equipment, aircraft/spacecraft, nuclear power controllers, fuel controllers, car equipment including car accessories, safety devices, etc.) and whose malfunction or failure may cause loss of human life, bodily injury or serious damage to property ("Specific Applications"), please consult with the ROHM sales representative in advance. Unless otherwise agreed in writing by ROHM in advance, ROHM shall not be in any way responsible or liable for any damages, expenses or losses incurred by you or third parties arising from the use of any ROHM's Products for Specific Applications.

(Note1) Medical Equipment Classification of the Specific Applications

JAPAN	USA	EU	CHINA
CLASS III	CLASS III	CLASS II b	CLASS III
CLASS IV		CLASS III	

- ROHM designs and manufactures its Products subject to strict quality control system. However, semiconductor products can fail or malfunction at a certain rate. Please be sure to implement, at your own responsibilities, adequate safety measures including but not limited to fail-safe design against the physical injury, damage to any property, which a failure or malfunction of our Products may cause. The following are examples of safety measures:
 - Installation of protection circuits or other protective devices to improve system safety
 - Installation of redundant circuits to reduce the impact of single or multiple circuit failure
- Our Products are designed and manufactured for use under standard conditions and not under any special or extraordinary environments or conditions, as exemplified below. Accordingly, ROHM shall not be in any way responsible or liable for any damages, expenses or losses arising from the use of any ROHM's Products under any special or extraordinary environments or conditions. If you intend to use our Products under any special or extraordinary environments or conditions (as exemplified below), your independent verification and confirmation of product performance, reliability, etc. prior to use, must be necessary:
 - Use of our Products in any types of liquid, including water, oils, chemicals, and organic solvents
 - Use of our Products outdoors or in places where the Products are exposed to direct sunlight or dust
 - Use of our Products in places where the Products are exposed to sea wind or corrosive gases, including Cl₂, H₂S, NH₃, SO₂, and NO₂
 - Use of our Products in places where the Products are exposed to static electricity or electromagnetic waves
 - Use of our Products in proximity to heat-producing components, plastic cords, or other flammable items
 - Sealing or coating our Products with resin or other coating materials
 - Use of our Products without cleaning residue of flux (even if you use no-clean type fluxes, cleaning residue of flux is recommended); or Washing our Products by using water or water-soluble cleaning agents for cleaning residue after soldering
 - Use of the Products in places subject to dew condensation
- The Products are not subject to radiation-proof design.
- Please verify and confirm characteristics of the final or mounted products in using the Products.
- In particular, if a transient load (a large amount of load applied in a short period of time, such as pulse. is applied, confirmation of performance characteristics after on-board mounting is strongly recommended. Avoid applying power exceeding normal rated power; exceeding the power rating under steady-state loading condition may negatively affect product performance and reliability.
- De-rate Power Dissipation (Pd) depending on Ambient temperature (Ta). When used in sealed area, confirm the actual ambient temperature.
- Confirm that operation temperature is within the specified range described in the product specification.
- ROHM shall not be in any way responsible or liable for failure induced under deviant condition from what is defined in this document.

Precaution for Mounting / Circuit board design

- When a highly active halogenous (chlorine, bromine, etc.) flux is used, the residue of flux may negatively affect product performance and reliability.
- In principle, the reflow soldering method must be used; if flow soldering method is preferred, please consult with the ROHM representative in advance.

For details, please refer to ROHM Mounting specification

Precautions Regarding Application Examples and External Circuits

1. If change is made to the constant of an external circuit, please allow a sufficient margin considering variations of the characteristics of the Products and external components, including transient characteristics, as well as static characteristics.
2. You agree that application notes, reference designs, and associated data and information contained in this document are presented only as guidance for Products use. Therefore, in case you use such information, you are solely responsible for it and you must exercise your own independent verification and judgment in the use of such information contained in this document. ROHM shall not be in any way responsible or liable for any damages, expenses or losses incurred by you or third parties arising from the use of such information.

Precaution for Electrostatic

This Product is electrostatic sensitive product, which may be damaged due to electrostatic discharge. Please take proper caution in your manufacturing process and storage so that voltage exceeding the Products maximum rating will not be applied to Products. Please take special care under dry condition (e.g. Grounding of human body / equipment / solder iron, isolation from charged objects, setting of Ionizer, friction prevention and temperature / humidity control).

Precaution for Storage / Transportation

1. Product performance and soldered connections may deteriorate if the Products are stored in the places where:
 - [a] the Products are exposed to sea winds or corrosive gases, including Cl₂, H₂S, NH₃, SO₂, and NO₂
 - [b] the temperature or humidity exceeds those recommended by ROHM
 - [c] the Products are exposed to direct sunshine or condensation
 - [d] the Products are exposed to high Electrostatic
2. Even under ROHM recommended storage condition, solderability of products out of recommended storage time period may be degraded. It is strongly recommended to confirm solderability before using Products of which storage time is exceeding the recommended storage time period.
3. Store / transport cartons in the correct direction, which is indicated on a carton with a symbol. Otherwise bent leads may occur due to excessive stress applied when dropping of a carton.
4. Use Products within the specified time after opening a humidity barrier bag. Baking is required before using Products of which storage time is exceeding the recommended storage time period.

Precaution for Product Label

QR code printed on ROHM Products label is for ROHM's internal use only.

Precaution for Disposition

When disposing Products please dispose them properly using an authorized industry waste company.

Precaution for Foreign Exchange and Foreign Trade act

Since our Products might fall under controlled goods prescribed by the applicable foreign exchange and foreign trade act, please consult with ROHM representative in case of export.

Precaution Regarding Intellectual Property Rights

1. All information and data including but not limited to application example contained in this document is for reference only. ROHM does not warrant that foregoing information or data will not infringe any intellectual property rights or any other rights of any third party regarding such information or data. ROHM shall not be in any way responsible or liable for infringement of any intellectual property rights or other damages arising from use of such information or data.:
2. No license, expressly or implied, is granted hereby under any intellectual property rights or other rights of ROHM or any third parties with respect to the information contained in this document.

Other Precaution



1. This document may not be reprinted or reproduced, in whole or in part, without prior written consent of ROHM.
2. The Products may not be disassembled, converted, modified, reproduced or otherwise changed without prior written consent of ROHM.
3. In no event shall you use in any way whatsoever the Products and the related technical information contained in the Products or this document for any military purposes, including but not limited to, the development of mass-destruction weapons.
4. The proper names of companies or products described in this document are trademarks or registered trademarks of ROHM, its affiliated companies or third parties.

General Precaution

1. Before you use our Products, you are requested to carefully read this document and fully understand its contents. ROHM shall not be in any way responsible or liable for failure, malfunction or accident arising from the use of any ROHM's Products against warning, caution or note contained in this document.
2. All information contained in this document is current as of the issuing date and subject to change without any prior notice. Before purchasing or using ROHM's Products, please confirm the latest information with a ROHM sales representative.
3. The information contained in this document is provided on an "as is" basis and ROHM does not warrant that all information contained in this document is accurate and/or error-free. ROHM shall not be in any way responsible or liable for any damages, expenses or losses incurred by you or third parties resulting from inaccuracy or errors of or concerning such information.

Looking for pricing, stock, or lifecycle information?

Click below to explore more details on WIN SOURCE:

-  [View BH7884EFV on WIN SOURCE](#)
-  [Rohm Semiconductor](#) Information

Optimize Your Supply Chain with WIN SOURCE Solutions

-  Global Sourcing Solution
-  Obsolete Management
-  Cost Control Management
-  Shortage Management
-  Alternative Solution
-  Excess Inventory Management