



CIO RLD RAM[®] 2

MT49H32M9 – 32 Meg x 9 x 8 Banks

MT49H16M18 – 16 Meg x 18 x 8 Banks

MT49H8M36 – 8 Meg x 36 x 8 Banks

Features

- 533 MHz DDR operation (1.067 Gb/s/pin data rate)
- 38.4 Gb/s peak bandwidth (x36 at 533 MHz clock frequency)
- Organization
 - 32 Meg x 9, 16 Meg x 18, and 8 Meg x 36
- 8 internal banks for concurrent operation and maximum bandwidth
- Reduced cycle time (15ns at 533 MHz)
- Nonmultiplexed addresses (address multiplexing option available)
- SRAM-type interface
- Programmable READ latency (RL), row cycle time, and burst sequence length
- Balanced READ and WRITE latencies in order to optimize data bus utilization
- Data mask for WRITE commands
- Differential input clocks (CK, CK#)
- Differential input data clocks (DKx, DKx#)
- On-die DLL generates CK edge-aligned data and output data clock signals
- Data valid signal (QVLD)
- 32ms refresh (8K refresh for each bank; 64K refresh command must be issued in total each 32ms)
- 144-ball μ BGA package
- HSTL I/O (1.5V or 1.8V nominal)
- 25–60 Ω matched impedance outputs
- 2.5V V_{EXT}, 1.8V V_{DD}, 1.5V or 1.8V V_{DDQ} I/O
- On-die termination (ODT) R_{TT}

Options¹

- Clock cycle timing
 - 1.875ns @ t_{RC} = 15ns
 - 2.5ns @ t_{RC} = 15ns
 - 2.5ns @ t_{RC} = 20ns
 - 3.3ns @ t_{RC} = 20ns
 - 5.0ns @ t_{RC} = 20ns
- Configuration
 - 32 Meg x 9
 - 16 Meg x 18
 - 8 Meg x 36
- Operating temperature
 - Commercial (0° to +95°C)
 - Industrial (T_C = –40°C to +95°C; T_A = –40°C to +85°C)
- Package
 - 144-ball μ BGA
 - 144-ball μ BGA (Pb-free)
- Revision

Marking

- 18
- 25E
- 25
- 33
- 5
- 32M9
- 16M18
- 8M36
- None
- IT
- FM
- BM
- :B

Notes: 1. Not all options listed can be combined to define an offered product. Use the part catalog search on www.micron.com for available offerings.

Figure 1: 288Mb RLD RAM 2 CIO Part Numbers

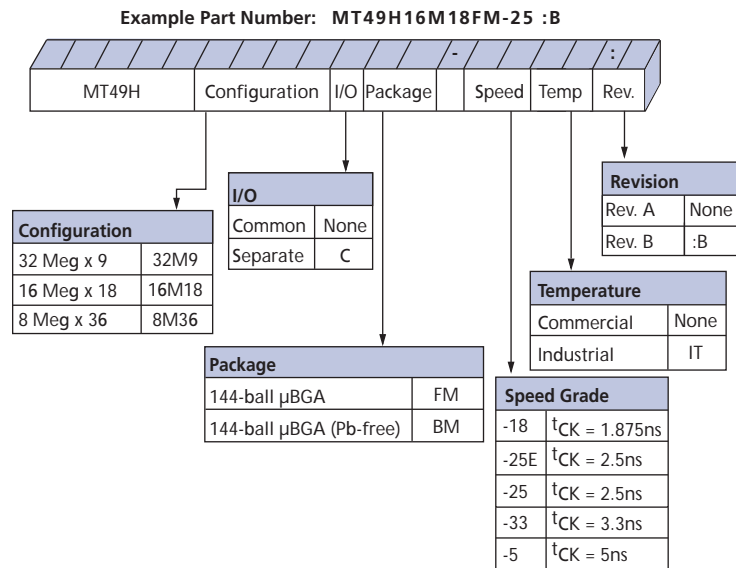

BGA Part Marking Decoder

Due to space limitations, BGA-packaged components have an abbreviated part marking that is different from the part number. Micron's BGA Part Marking Decoder is available on Micron's Web site at micron.com.



Table of Contents

Features	1
BGA Part Marking Decoder	2
General Description	6
State Diagram	7
Functional Block Diagrams	8
Ball Assignments and Descriptions	11
Package Dimensions	16
Electrical Specifications – I_{DD}	17
Electrical Specifications – AC and DC	20
Absolute Maximum Ratings	20
AC and DC Operating Conditions	20
Input Slew Rate Derating	23
Notes	29
Temperature and Thermal Impedance	30
Commands	32
MODE REGISTER SET (MRS)	33
WRITE	39
READ	40
AUTO REFRESH (AREF)	41
Operations	42
INITIALIZATION	42
WRITE	45
READ	50
AUTO REFRESH	56
On-Die Termination	57
Multiplexed Address Mode	59
IEEE 1149.1 Serial Boundary Scan (JTAG)	68
Disabling the JTAG Feature	68
Test Access Port (TAP)	68
TAP Controller	69
Performing a TAP RESET	71
TAP Registers	71
TAP Instruction Set	72

List of Figures

Figure 1:	288Mb RLD RAM 2 CIO Part Numbers	2
Figure 2:	Simplified State Diagram	7
Figure 3:	32 Meg x 9 Functional Block Diagram	8
Figure 4:	16 Meg x 18 Functional Block Diagram	9
Figure 5:	8 Meg x 36 Functional Block Diagram	10
Figure 6:	144-Ball μ BGA	16
Figure 7:	Clock Input	22
Figure 8:	Nominal tAS/tCS/tDS and tAH/tCH/tDH Slew Rate	26
Figure 9:	Example Temperature Test Point Location	31
Figure 10:	Mode Register Definition in Nonmultiplexed Address Mode	34
Figure 11:	Read Burst Lengths	36
Figure 12:	On-Die Termination-Equivalent Circuit	38
Figure 13:	WRITE Command	39
Figure 14:	READ Command	40
Figure 15:	AUTO REFRESH Command	41
Figure 16:	Power-Up/Initialization Sequence	43
Figure 17:	Power-Up/Initialization Flow Chart	44
Figure 18:	WRITE Burst	45
Figure 19:	Consecutive WRITE-to-WRITE	46
Figure 20:	WRITE-to-READ	47
Figure 21:	WRITE-to-READ (Separated by Two NOPs)	48
Figure 22:	WRITE – DM Operation	49
Figure 23:	Basic READ Burst Timing	50
Figure 24:	Consecutive READ Bursts (BL = 2)	51
Figure 25:	Consecutive READ Bursts (BL = 4)	51
Figure 26:	READ-to-WRITE	52
Figure 27:	Read Data Valid Window for x9 Device	53
Figure 28:	Read Data Valid Window for x18 Device	54
Figure 29:	Read Data Valid Window for x36 Device	55
Figure 30:	AUTO REFRESH Cycle	56
Figure 31:	READ Burst with ODT	57
Figure 32:	READ-NOP-READ with ODT	58
Figure 34:	Command Description in Multiplexed Address Mode	59
Figure 35:	Power-Up/Initialization Sequence in Multiplexed Address Mode	60
Figure 36:	Mode Register Definition in Multiplexed Address Mode	61
Figure 37:	BURST REFRESH Operation with Multiplexed Addressing	63
Figure 38:	Consecutive WRITE Bursts with Multiplexed Addressing	64
Figure 39:	WRITE-to-READ with Multiplexed Addressing	65
Figure 40:	Consecutive READ Bursts with Multiplexed Addressing	66
Figure 41:	READ-to-WRITE with Multiplexed Addressing	67
Figure 42:	TAP Controller State Diagram	70
Figure 43:	TAP Controller Block Diagram	70
Figure 44:	JTAG Operation – Loading Instruction Code and Shifting Out Data	73
Figure 45:	TAP Timing	74

List of Tables

Table 1:	32 Meg x 9 Ball Assignments (Top View) 144-Ball μ BGA	11
Table 2:	16 Meg x 18 Ball Assignments (Top View) 144-Ball μ BGA	12
Table 3:	8 Meg x 36 Ball Assignments (Top View) 144-Ball μ BGA	13
Table 4:	Ball Descriptions	14
Table 5:	I_{DD} Operating Conditions and Maximum Limits – Rev. A	17
Table 6:	I_{DD} Operating Conditions and Maximum Limits – Rev. B	18
Table 7:	Absolute Maximum Ratings	20
Table 8:	DC Electrical Characteristics and Operating Conditions	20
Table 9:	Input AC Logic Levels	21
Table 10:	Differential Input Clock Operating Conditions	22
Table 11:	Address and Command Setup and Hold Derating Values	24
Table 12:	Data Setup and Hold Derating Values	25
Table 13:	Capacitance – μ BGA	26
Table 14:	AC Electrical Characteristics: -18, -25E, -25, -33, -5	27
Table 15:	Temperature Limits	30
Table 16:	Thermal Impedance	31
Table 17:	Description of Commands	32
Table 18:	Command Table	32
Table 19:	Cycle Time and READ/WRITE Latency Configuration Table	35
Table 20:	Address Widths at Different Burst Lengths	36
Table 21:	On-Die Termination DC Parameters	38
Table 22:	288Mb Address Mapping in Multiplexed Address Mode	62
Table 23:	Cycle Time and READ/WRITE Latency Configuration Table in Multiplexed Mode	63
Table 24:	TAP Input AC Logic Levels	74
Table 25:	TAP AC Electrical Characteristics	74
Table 26:	TAP DC Electrical Characteristics and Operating Conditions	75
Table 27:	Identification Register Definitions	75
Table 28:	Scan Register Sizes	75
Table 29:	Instruction Codes	76
Table 30:	Boundary Scan (Exit) Order	76

General Description

The Micron[®] reduced latency DRAM (RLDRAM[®]) 2 is a high-speed memory device designed for high bandwidth data storage—telecommunications, networking, and cache applications, etc. The chip's 8-bank architecture is optimized for sustainable high speed operation.

The DDR I/O interface transfers two data words per clock cycle at the I/O balls. Output data is referenced to the free-running output data clock.

Commands, addresses, and control signals are registered at every positive edge of the differential input clock, while input data is registered at both positive and negative edges of the input data clock(s).

Read and write accesses to the RLD RAM are burst-oriented. The burst length (BL) is programmable from 2, 4, or 8 by setting the mode register.

The device is supplied with 2.5V and 1.8V for the core and 1.5V or 1.8V for the output drivers.

Bank-scheduled refresh is supported with the row address generated internally.

The μ BGA 144-ball package is used to enable ultra high-speed data transfer rates and a simple upgrade path from early generation devices.

State Diagram

Figure 2: Simplified State Diagram

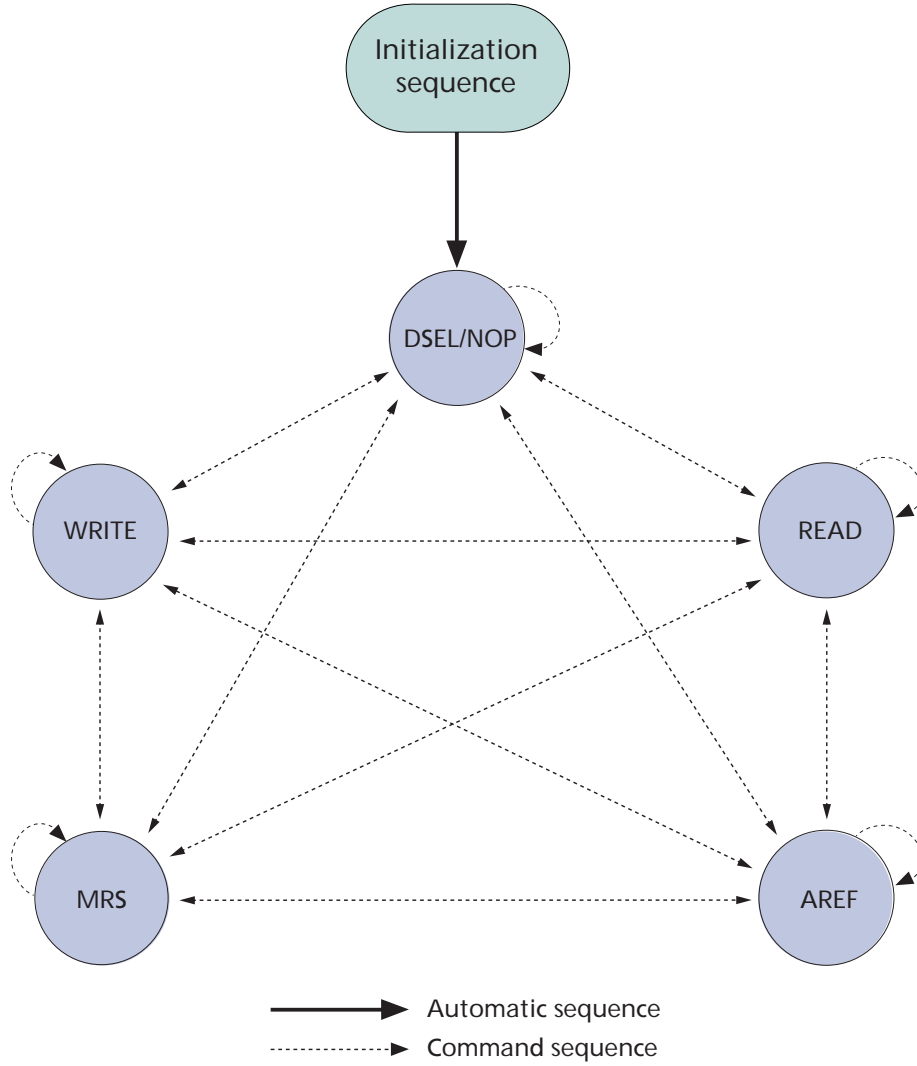

Functional Block Diagrams

Figure 3: 32 Meg x 9 Functional Block Diagram

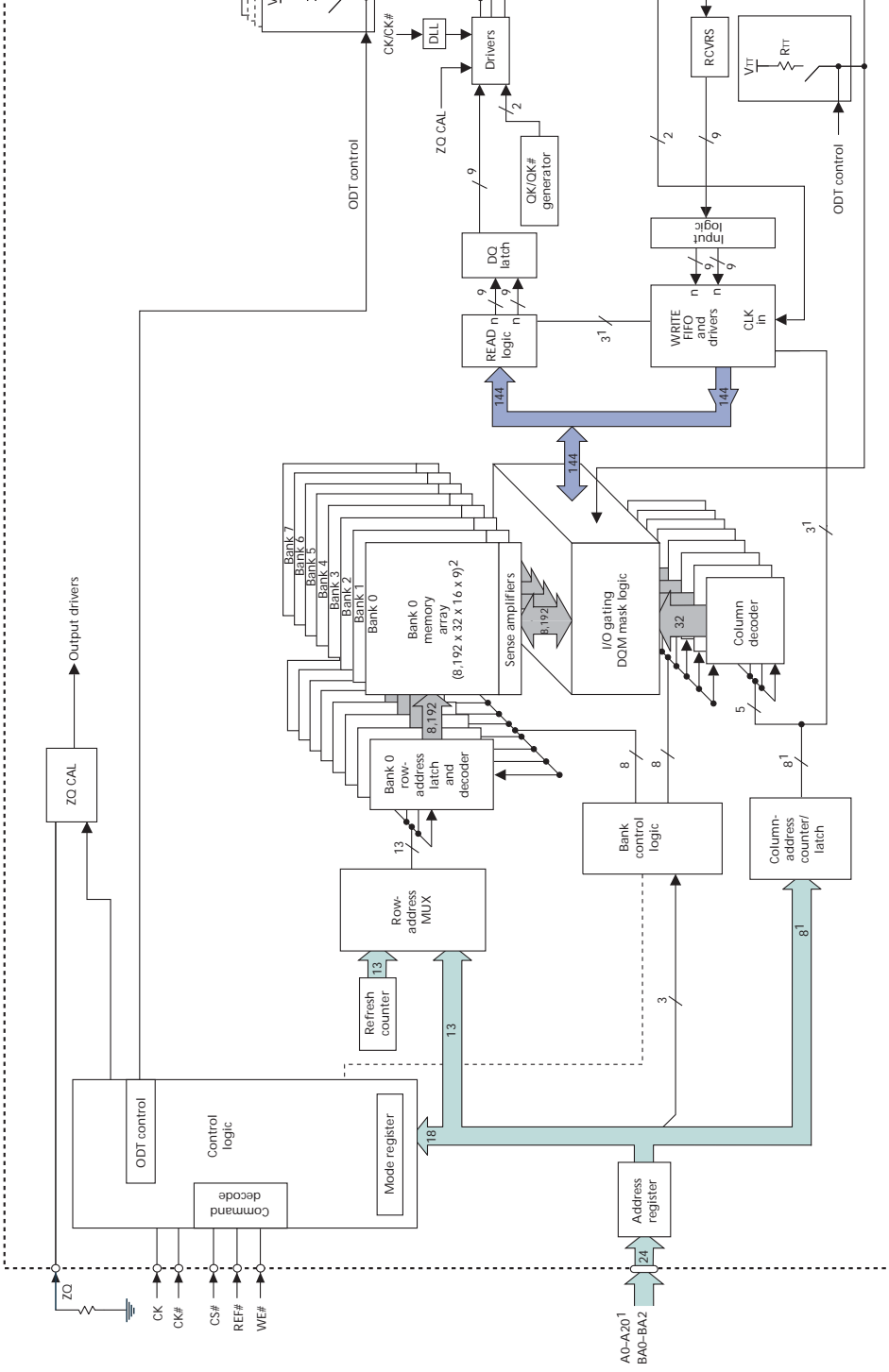

- Notes:
1. Examples for BL = 2; column address will be reduced with an increase in burst length.
 2. The "16" = (length of burst) x 2^(number of column addresses to WRITE FIFO and READ logic).

Figure 4: 16 Meg x 18 Functional Block Diagram

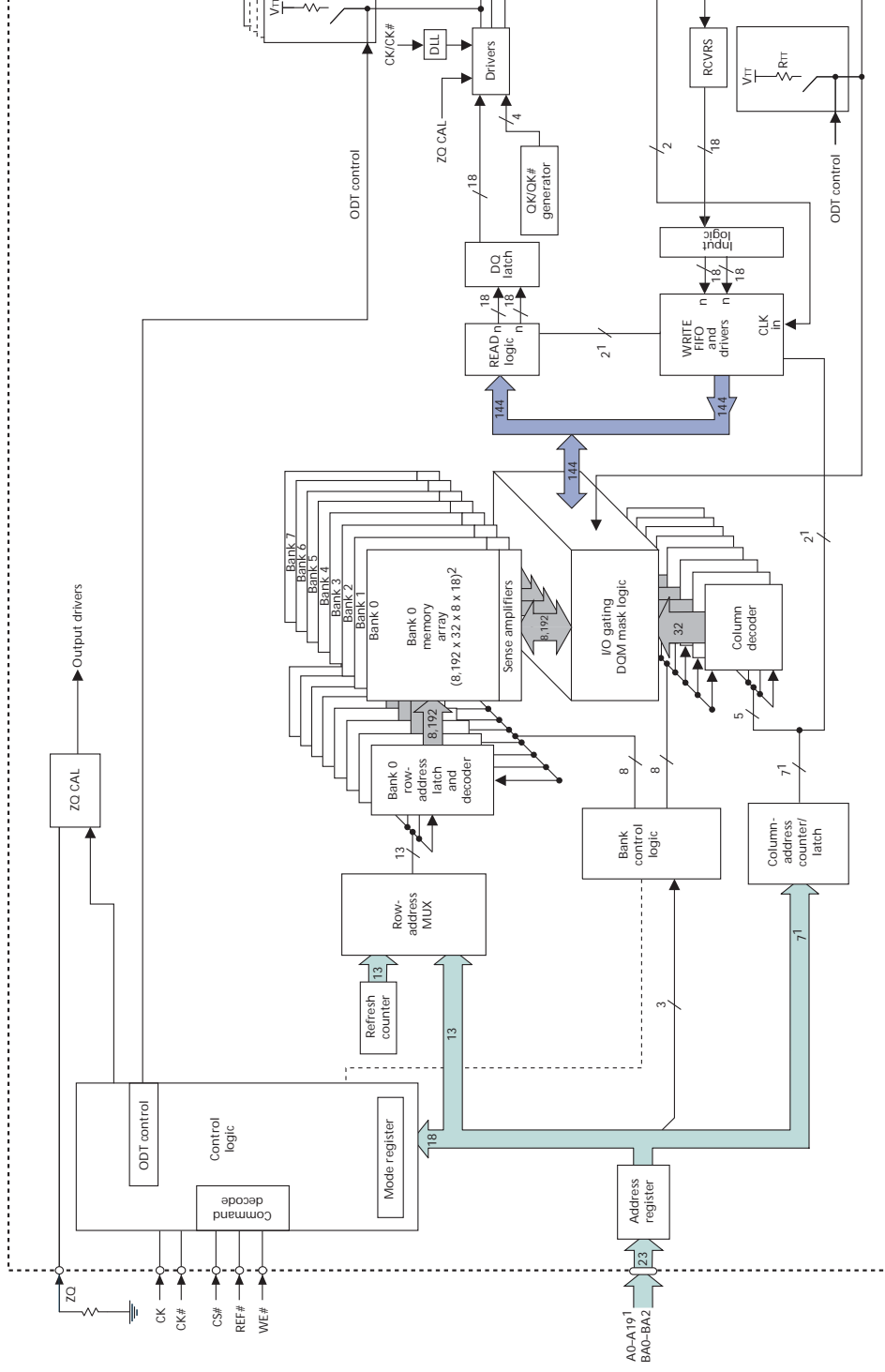

- Notes:
1. Examples for BL = 2; column address will be reduced with an increase in burst length.
 2. The "8" = (length of burst) x 2^(number of column addresses to WRITE FIFO and READ logic).

Figure 5: 8 Meg x 36 Functional Block Diagram

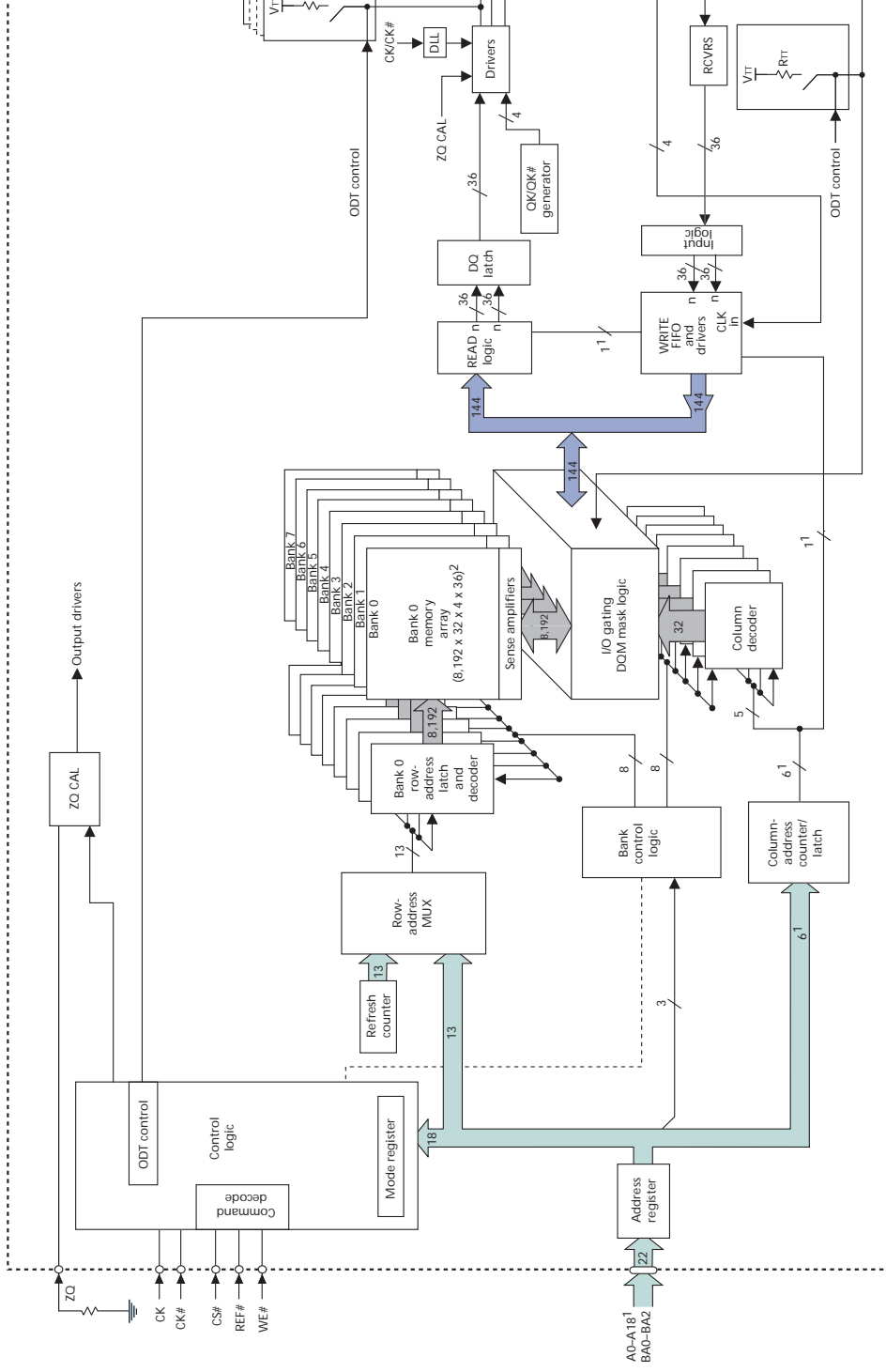

- Notes:
1. Examples for BL = 2; column address will be reduced with an increase in burst length.
 2. The "4" = (length of burst) x 2^(number of column addresses to WRITE FIFO and READ logic).



Ball Assignments and Descriptions

Table 1: 32 Meg x 9 Ball Assignments (Top View) 144-Ball μ BGA

	1	2	3	4	5	6	7	8	9	10	11	12
A	V_{REF}	V_{SS}	V_{EXT}	V_{SS}					V_{SS}	V_{EXT}	TMS	TCK
B	V_{DD}	DNU ⁴	DNU ⁴	V_{SSQ}					V_{SSQ}	DQ0	DNU ⁴	V_{DD}
C	V_{TT}	DNU ⁴	DNU ⁴	V_{DDQ}					V_{DDQ}	DQ1	DNU ⁴	V_{TT}
D	A22 ¹	DNU ⁴	DNU ⁴	V_{SSQ}					V_{SSQ}	QK0#	QK0	V_{SS}
E	A21 ²	DNU ⁴	DNU ⁴	V_{DDQ}					V_{DDQ}	DQ2	DNU ⁴	A20
F	A5	DNU ⁴	DNU ⁴	V_{SSQ}					V_{SSQ}	DQ3	DNU ⁴	QVLD
G	A8	A6	A7	V_{DD}					V_{DD}	A2	A1	A0
H	B2	A9	V_{SS}	V_{SS}					V_{SS}	V_{SS}	A4	A3
J	NF ³	NF ³	V_{DD}	V_{DD}					V_{DD}	V_{DD}	B0	CK
K	DK	DK#	V_{DD}	V_{DD}					V_{DD}	V_{DD}	B1	CK#
L	REF#	CS#	V_{SS}	V_{SS}					V_{SS}	V_{SS}	A14	A13
M	WE#	A16	A17	V_{DD}					V_{DD}	A12	A11	A10
N	A18	DNU ⁴	DNU ⁴	V_{SSQ}					V_{SSQ}	DQ4	DNU ⁴	A19
P	A15	DNU ⁴	DNU ⁴	V_{DDQ}					V_{DDQ}	DQ5	DNU ⁴	DM
R	V_{SS}	DNU ⁴	DNU ⁴	V_{SSQ}					V_{SSQ}	DQ6	DNU ⁴	V_{SS}
T	V_{TT}	DNU ⁴	DNU ⁴	V_{DDQ}					V_{DDQ}	DQ7	DNU ⁴	V_{TT}
U	V_{DD}	DNU ⁴	DNU ⁴	V_{SSQ}					V_{SSQ}	DQ8	DNU ⁴	V_{DD}
V	V_{REF}	ZQ	V_{EXT}	V_{SS}					V_{SS}	V_{EXT}	TDO	TDI

- Notes:
1. Reserved for future use. This signal is not connected.
 2. Reserved for future use. This signal is internally connected and has parasitic characteristics of an address input signal.
 3. No function. This signal is internally connected and has parasitic characteristics of a clock input signal. This may optionally be connected to GND.
 4. Do not use. This signal is internally connected and has parasitic characteristics of a I/O. This may optionally be connected to GND. Note that if ODT is enabled on Rev. A die, these pins will be connected to V_{TT} . The DNU pins are High-Z on Rev. B die when ODT is enabled.



Table 2: 16 Meg x 18 Ball Assignments (Top View) 144-Ball μ BGA

	1	2	3	4	5	6	7	8	9	10	11	12
A	V_{REF}	V_{SS}	V_{EXT}	V_{SS}					V_{SS}	V_{EXT}	TMS	TCK
B	V_{DD}	DNU ⁴	DQ4	V_{SSQ}					V_{SSQ}	DQ0	DNU ⁴	V_{DD}
C	V_{TT}	DNU ⁴	DQ5	V_{DDQ}					V_{DDQ}	DQ1	DNU ⁴	V_{TT}
D	A22 ¹	DNU ⁴	DQ6	V_{SSQ}					V_{SSQ}	QK0#	QK0	V_{SS}
E	A21 ²	DNU ⁴	DQ7	V_{DDQ}					V_{DDQ}	DQ2	DNU ⁴	A20 ²
F	A5	DNU ⁴	DQ8	V_{SSQ}					V_{SSQ}	DQ3	DNU ⁴	QVLD
G	A8	A6	A7	V_{DD}					V_{DD}	A2	A1	A0
H	B2	A9	V_{SS}	V_{SS}					V_{SS}	V_{SS}	A4	A3
J	NF ³	NF ³	V_{DD}	V_{DD}					V_{DD}	V_{DD}	B0	CK
K	DK	DK#	V_{DD}	V_{DD}					V_{DD}	V_{DD}	B1	CK#
L	REF#	CS#	V_{SS}	V_{SS}					V_{SS}	V_{SS}	A14	A13
M	WE#	A16	A17	V_{DD}					V_{DD}	A12	A11	A10
N	A18	DNU ⁴	DQ14	V_{SSQ}					V_{SSQ}	DQ9	DNU ⁴	A19
P	A15	DNU ⁴	DQ15	V_{DDQ}					V_{DDQ}	DQ10	DNU ⁴	DM
R	V_{SS}	QK1	QK1#	V_{SSQ}					V_{SSQ}	DQ11	DNU ⁴	V_{SS}
T	V_{TT}	DNU ⁴	DQ16	V_{DDQ}					V_{DDQ}	DQ12	DNU ⁴	V_{TT}
U	V_{DD}	DNU ⁴	DQ17	V_{SSQ}					V_{SSQ}	DQ13	DNU ⁴	V_{DD}
V	V_{REF}	ZQ	V_{EXT}	V_{SS}					V_{SS}	V_{EXT}	TDO	TDI

- Notes:
1. Reserved for future use. This may optionally be connected to GND.
 2. Reserved for future use. This signal is internally connected and has parasitic characteristics of an address input signal. This may optionally be connected to GND.
 3. No function. This signal is internally connected and has parasitic characteristics of a clock input signal. This may optionally be connected to GND.
 4. Do not use. This signal is internally connected and has parasitic characteristics of a I/O. This may optionally be connected to GND. Note that if ODT is enabled on Rev. A die, these pins will be connected to V_{TT} . The DNU pins are High-Z on Rev. B die when ODT is enabled.



Table 3: 8 Meg x 36 Ball Assignments (Top View) 144-Ball μ BGA

	1	2	3	4	5	6	7	8	9	10	11	12
A	V_{REF}	V_{SS}	V_{EXT}	V_{SS}					V_{SS}	V_{EXT}	TMS	TCK
B	V_{DD}	DQ8	DQ9	V_{SSQ}					V_{SSQ}	DQ1	DQ0	V_{DD}
C	V_{TT}	DQ10	DQ11	V_{DDQ}					V_{DDQ}	DQ3	DQ2	V_{TT}
D	A22	DQ12	DQ13	V_{SSQ}					V_{SSQ}	QK0#	QK0	V_{SS}
E	A21 ²	DQ14	DQ15	V_{DDQ}					V_{DDQ}	DQ5	DQ4	A20 ²
F	A5	DQ16	DQ17	V_{SSQ}					V_{SSQ}	DQ7	DQ6	QVLD
G	A8	A6	A7	V_{DD}					V_{DD}	A2	A1	A0
H	B2	A9	V_{SS}	V_{SS}					V_{SS}	V_{SS}	A4	A3
J	DK0	DK0#	V_{DD}	V_{DD}					V_{DD}	V_{DD}	B0	CK
K	DK1	DK1#	V_{DD}	V_{DD}					V_{DD}	V_{DD}	B1	CK#
L	REF#	CS#	V_{SS}	V_{SS}					V_{SS}	V_{SS}	A14	A13
M	WE#	A16	A17	V_{DD}					V_{DD}	A12	A11	A10
N	A18	DQ24	DQ25	V_{SSQ}					V_{SSQ}	DQ35	DQ34	A19 ²
P	A15	DQ22	DQ23	V_{DDQ}					V_{DDQ}	DQ33	DQ32	DM
R	V_{SS}	QK1	QK1#	V_{SSQ}					V_{SSQ}	DQ31	DQ30	V_{SS}
T	V_{TT}	DQ20	DQ21	V_{DDQ}					V_{DDQ}	DQ29	DQ28	V_{TT}
U	V_{DD}	DQ18	DQ19	V_{SSQ}					V_{SSQ}	DQ27	DQ26	V_{DD}
V	V_{REF}	ZQ	V_{EXT}	V_{SS}					V_{SS}	V_{EXT}	TDO	TDI

- Notes:
1. Reserved for future use. This may optionally be connected to GND.
 2. Reserved for future use. This signal is internally connected and has parasitic characteristics of an address input signal. This may optionally be connected to GND.

Table 4: Ball Descriptions

Symbol	Type	Description
A0–A20	Input	Address inputs: A0–A20 define the row and column addresses for READ and WRITE operations. During a MODE REGISTER SET, the address inputs define the register settings. They are sampled at the rising edge of CK.
BA0–BA2	Input	Bank address inputs: Select to which internal bank a command is being applied.
CK, CK#	Input	Input clock: CK and CK# are differential input clocks. Addresses and commands are latched on the rising edge of CK. CK# is ideally 180 degrees out of phase with CK.
CS#	Input	Chip select: CS# enables the command decoder when LOW and disables it when HIGH. When the command decoder is disabled, new commands are ignored, but internal operations continue.
DK, DK#	Input	Input data clock: DK and DK# are the differential input data clocks. All input data is referenced to both edges of DK. DK# is ideally 180 degrees out of phase with DK. For the x36 device, DQ0–DQ17 are referenced to DK0 and DK0# and DQ18–DQ35 are referenced to DK1 and DK1#. For the x9 and x18 devices, all DQs are referenced to DK and DK#. All DKx and DKx# pins must always be supplied to the device.
DM	Input	Input data mask: The DM signal is the input mask signal for WRITE data. Input data is masked when DM is sampled HIGH. DM is sampled on both edges of DK (DK1 for the x36 configuration). Tie signal to ground if not used.
TCK	Input	IEEE 1149.1 clock input: This ball must be tied to V_{SS} if the JTAG function is not used.
TMS, TDI	Input	IEEE 1149.1 test inputs: These balls may be left as no connects if the JTAG function is not used.
WE#, REF#	Input	Command inputs: Sampled at the positive edge of CK, WE# and REF# define (together with CS#) the command to be executed.
DQ0–DQ35	I/O	Data input: The DQ signals form the 36-bit data bus. During READ commands, the data is referenced to both edges of QKx. During WRITE commands, the data is sampled at both edges of DK.
ZQ	Reference	External impedance (25–60Ω): This signal is used to tune the device outputs to the system data bus impedance. DQ output impedance is set to $0.2 \times RQ$, where RQ is a resistor from this signal to ground. Connecting ZQ to GND invokes the minimum impedance mode. Connecting ZQ to V_{DD} invokes the maximum impedance mode. Refer to the Mode Register Definition in Nonmultiplexed Address Mode figure to activate this function.
QKx, QKx#	Output	Output data clocks: QKx and QKx# are opposite polarity, output data clocks. They are free-running, and during READs, are edge-aligned with data output from the RLD RAM. QKx# is ideally 180 degrees out of phase with QKx. For the x36 device, QK0 and QK0# are aligned with DQ0–DQ17, and QK1 and QK1# are aligned with DQ18–DQ35. For the x18 device, QK0 and QK0# are aligned with DQ0–DQ8, while QK1 and QK1# are aligned with Q9–Q17. For the x9 device, all DQs are aligned with QK0 and QK0#.
QVLD	Output	Data valid: The QVLD pin indicates valid output data. QVLD is edge-aligned with QKx and QKx#.
TDO	Output	IEEE 1149.1 test output: JTAG output. This ball may be left as no connect if the JTAG function is not used.
V_{DD}	Supply	Power supply: Nominally, 1.8V. See Table 8 on page 20 for range.
V_{DDQ}	Supply	DQ power supply: Nominally, 1.5V or 1.8V. Isolated on the device for improved noise immunity. See Table 8 on page 20 for range.
V_{EXT}	Supply	Power supply: Nominally, 2.5V. See Table 8 on page 20 for range.
V_{REF}	Supply	Input reference voltage: Nominally $V_{DDQ}/2$. Provides a reference voltage for the input buffers.
V_{SS}	Supply	Ground.
V_{SSQ}	Supply	DQ ground: Isolated on the device for improved noise immunity.
V_{TT}	Supply	Power supply: Isolated termination supply. Nominally, $V_{DDQ}/2$. See Table 8 on page 20 for range.
A21	–	Reserved for future use: This signal is internally connected and can be treated as an address input.
A22	–	Reserved for future use: This signal is not connected and can be connected to ground.

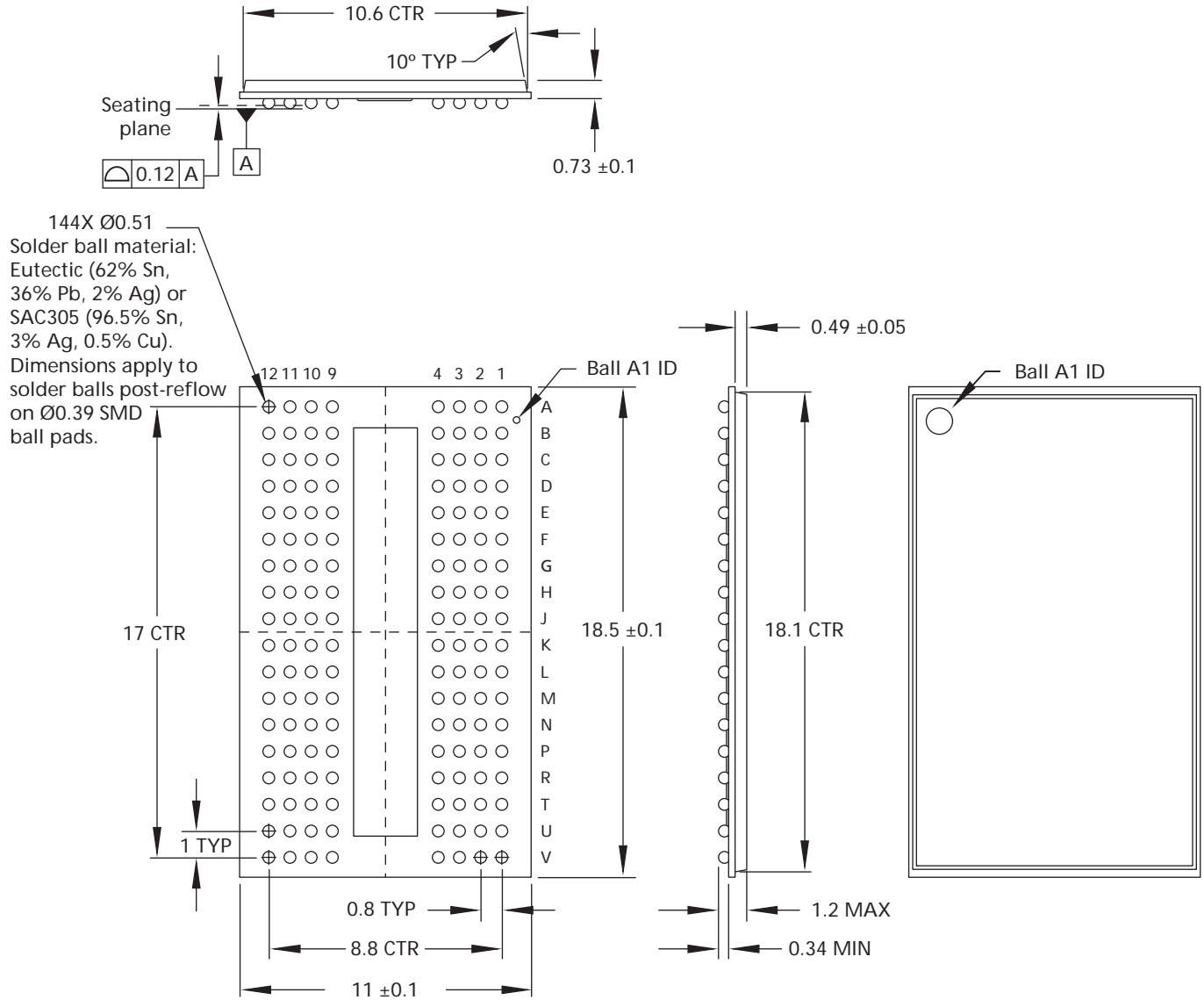

Table 4: Ball Descriptions (continued)

Symbol	Type	Description
DNU	-	Do not use: These balls may be connected to ground. Note that if ODT is enabled on Rev. A die, these pins will be connected to V_{TT} . The DNU pins are High-Z on Rev. B die when ODT is enabled.
NF	-	No function: These balls can be connected to ground.

Package Dimensions

Figure 6: 144-Ball μ BGA



Notes: 1. All dimensions are in millimeters.

Electrical Specifications - I_{DD}

Table 5: I_{DD} Operating Conditions and Maximum Limits - Rev. A

Notes appear on page 19

Description	Condition	Symbol	-25	-33	-5	Units
Standby current	t _{CK} = idle; All banks idle; No inputs toggling	I _{SB1} (V _{DD}) x9/x18	48	48	48	mA
		I _{SB1} (V _{DD}) x36	48	48	48	
		I _{SB1} (V _{EXT})	26	26	26	
Active standby current	CS# = 1; No commands; Bank address incremented and half address/data change once every 4 clock cycles	I _{SB2} (V _{DD}) x9/x18	288	233	189	mA
		I _{SB2} (V _{DD}) x36	288	233	189	
		I _{SB2} (V _{EXT})	26	26	26	
Operational current	BL = 2; Sequential bank access; Bank transitions once every t _{RC} ; Half address transitions once every t _{RC} ; Read followed by write sequence; continuous data during WRITE commands	I _{DD1} (V _{DD}) x9/x18	348	305	255	mA
		I _{DD1} (V _{DD}) x36	374	343	292	
		I _{DD1} (V _{EXT})	41	36	36	
Operational current	BL = 4; Sequential bank access; Bank transitions once every t _{RC} ; Half address transitions once every t _{RC} ; Read followed by write sequence; Continuous data during WRITE commands	I _{DD2} (V _{DD}) x9/x18	362	319	269	mA
		I _{DD2} (V _{DD}) x36	418	389	339	
		I _{DD2} (V _{EXT})	48	42	42	
Operational current	BL = 8; Sequential bank access; Bank transitions once every t _{RC} ; half address transitions once every t _{RC} ; Read followed by write sequence; continuous data during WRITE commands	I _{DD3} (V _{DD}) x9/x18	408	368	286	mA
		I _{DD3} (V _{DD}) x36	n/a	n/a	n/a	
		I _{DD3} (V _{EXT})	55	48	48	
Burst refresh current	Eight-bank cyclic refresh; Continuous address/data; Command bus remains in refresh for all eight banks	I _{REF1} (V _{DD}) x9/x18	785	615	430	mA
		I _{REF1} (V _{DD}) x36	785	615	430	
		I _{REF1} (V _{EXT})	133	111	105	
Distributed refresh current	Single-bank refresh; Sequential bank access; Half address transitions once every t _{RC} , continuous data	I _{REF2} (V _{DD}) x9/x18	325	267	221	mA
		I _{REF2} (V _{DD}) x36	326	281	227	
		I _{REF2} (V _{EXT})	48	42	42	
Operating burst write current example	BL = 2; Cyclic bank access; Half of address bits change every clock cycle; Continuous data; measurement is taken during continuous WRITE	I _{DD2W} (V _{DD}) x9/x18	970	819	597	mA
		I _{DD2W} (V _{DD}) x36	990	914	676	
		I _{DD2W} (V _{EXT})	100	90	69	
Operating burst write current example	BL = 4; Cyclic bank access; Half of address bits change every 2 clock cycles; Continuous data; Measurement is taken during continuous WRITE	I _{DD4W} (V _{DD}) x9/x18	779	609	439	mA
		I _{DD4W} (V _{DD}) x36	882	790	567	
		I _{DD4W} (V _{EXT})	88	77	63	
Operating burst write current example	BL = 8; Cyclic bank access; Half of address bits change every 4 clock cycles; continuous data; Measurement is taken during continuous WRITE	I _{DD8W} (V _{DD}) x9/x18	668	525	364	mA
		I _{DD8W} (V _{DD}) x36	n/a	n/a	n/a	
		I _{DD8W} (V _{EXT})	60	51	40	
Operating burst read current example	BL = 2; Cyclic bank access; Half of address bits change every clock cycle; Measurement is taken during continuous READ	I _{DD2R} (V _{DD}) x9/x18	860	735	525	mA
		I _{DD2R} (V _{DD}) x36	880	795	565	
		I _{DD2R} (V _{EXT})	100	90	69	
Operating burst read current example	BL = 4; Cyclic bank access; Half of address bits change every 2 clock cycles; Measurement is taken during continuous READ	I _{DD4R} (V _{DD}) x9/x18	680	525	380	mA
		I _{DD4R} (V _{DD}) x36	730	660	455	
		I _{DD4R} (V _{EXT})	88	77	63	



Table 5: I_{DD} Operating Conditions and Maximum Limits – Rev. A

Notes appear on page 19

Description	Condition	Symbol	-25	-33	-5	Units
Operating burst read current example	BL = 8; Cyclic bank access; Half of address bits change every 4 clock cycles; Measurement is taken during continuous READ	$I_{DD8R}(V_{DD})$ x9/x18	570	450	310	mA
		$I_{DD8R}(V_{DD})$ x36	n/a	n/a	n/a	
		$I_{DD8R}(V_{EXT})$	60	51	40	

Table 6: I_{DD} Operating Conditions and Maximum Limits – Rev. B

Notes appear on page 19

Description	Condition	Symbol	-18	-25E	-25	-33	Units
Standby current	t_{CK} = idle; All banks idle; No inputs toggling	$I_{SB1}(V_{DD})$ x9/x18	55	55	55	55	mA
		$I_{SB1}(V_{DD})$ x36	55	55	55	55	
		$I_{SB1}(V_{EXT})$	5	5	5	5	
Active standby current	CS# = 1; No commands; Bank address incremented and half address/data change once every 4 clock cycles	$I_{SB2}(V_{DD})$ x9/x18	250	215	215	190	mA
		$I_{SB2}(V_{DD})$ x36	250	215	215	190	
		$I_{SB2}(V_{EXT})$	5	5	5	5	
Operational current	BL = 2; Sequential bank access; Bank transitions once every t_{RC} ; Half address transitions once every t_{RC} ; Read followed by write sequence; continuous data during WRITE commands	$I_{DD1}(V_{DD})$ x9/x18	310	285	260	225	mA
		$I_{DD1}(V_{DD})$ x36	320	295	270	230	
		$I_{DD1}(V_{EXT})$	10	10	10	10	
Operational current	BL = 4; Sequential bank access; Bank transitions once every t_{RC} ; Half address transitions once every t_{RC} ; Read followed by write sequence; Continuous data during WRITE commands	$I_{DD2}(V_{DD})$ x9/x18	315	290	260	220	mA
		$I_{DD2}(V_{DD})$ x36	330	305	275	230	
		$I_{DD2}(V_{EXT})$	10	10	10	10	
Operational current	BL = 8; Sequential bank access; Bank transitions once every t_{RC} ; half address transitions once every t_{RC} ; Read followed by write sequence; continuous data during WRITE commands	$I_{DD3}(V_{DD})$ x9/x18	330	305	275	230	mA
		$I_{DD3}(V_{DD})$ x36	390	365	320	265	
		$I_{DD3}(V_{EXT})$	15	15	15	15	
Burst refresh current	Eight-bank cyclic refresh; Continuous address/data; Command bus remains in refresh for all eight banks	$I_{REF1}(V_{DD})$ x9/x18	660	540	530	430	mA
		$I_{REF1}(V_{DD})$ x36	670	545	535	435	
		$I_{REF1}(V_{EXT})$	45	30	30	25	
Distributed refresh current	Single-bank refresh; Sequential bank access; Half address transitions once every t_{RC} , continuous data	$I_{REF2}(V_{DD})$ x9/x18	295	265	250	215	mA
		$I_{REF2}(V_{DD})$ x36	295	265	250	215	
		$I_{REF2}(V_{EXT})$	10	10	10	10	
Operating burst write current example	BL = 2; Cyclic bank access; Half of address bits change every clock cycle; Continuous data; measurement is taken during continuous WRITE	$I_{DD2W}(V_{DD})$ x9/x18	830	655	655	530	mA
		$I_{DD2W}(V_{DD})$ x36	885	700	700	565	
		$I_{DD2W}(V_{EXT})$	40	35	35	30	
Operating burst write current example	BL = 4; Cyclic bank access; Half of address bits change every 2 clock cycles; Continuous data; Measurement is taken during continuous WRITE	$I_{DD4W}(V_{DD})$ x9/x18	580	465	465	385	mA
		$I_{DD4W}(V_{DD})$ x36	635	510	510	420	
		$I_{DD4W}(V_{EXT})$	25	20	20	20	
Operating burst write current example	BL = 8; Cyclic bank access; Half of address bits change every 4 clock cycles; continuous data; Measurement is taken during continuous WRITE	$I_{DD8W}(V_{DD})$ x9/x18	445	370	370	305	mA
		$I_{DD8W}(V_{DD})$ x36	560	455	455	375	
		$I_{DD8W}(V_{EXT})$	25	20	20	20	

Table 6: I_{DD} Operating Conditions and Maximum Limits – Rev. B (continued)

Notes appear on page 19

Description	Condition	Symbol	-18	-25E	-25	-33	Units
Operating burst read current example	BL = 2; Cyclic bank access; Half of address bits change every clock cycle; Measurement is taken during continuous READ	$I_{DD2R}(V_{DD})$ x9/x18	805	640	640	515	mA
		$I_{DD2R}(V_{DD})$ x36	850	675	675	540	
		$I_{DD2R}(V_{EXT})$	40	35	35	30	
Operating burst read current example	BL = 4; Cyclic bank access; Half of address bits change every 2 clock cycles; Measurement is taken during continuous READ	$I_{DD4R}(V_{DD})$ x9/x18	545	440	440	365	mA
		$I_{DD4R}(V_{DD})$ x36	590	475	475	390	
		$I_{DD4R}(V_{EXT})$	25	20	20	20	
Operating burst read current example	BL = 8; Cyclic bank access; Half of address bits change every 4 clock cycles; Measurement is taken during continuous READ	$I_{DD8R}(V_{DD})$ x9/x18	410	335	335	280	mA
		$I_{DD8R}(V_{DD})$ x36	525	425	425	350	
		$I_{DD8R}(V_{EXT})$	25	20	20	20	

- Notes:
- I_{DD} specifications are tested after the device is properly initialized. $+0^{\circ}\text{C} \leq T_C \leq +95^{\circ}\text{C}$; $+1.7\text{V} \leq V_{DD} \leq +1.9\text{V}$, $+2.38\text{V} \leq V_{EXT} \leq +2.63\text{V}$, $+1.4\text{V} \leq V_{DDQ} \leq V_{DD}$, $V_{REF} = V_{DDQ}/2$.
 - $t_{CK} = t_{DK} = \text{MIN}$, $t_{RC} = \text{MIN}$.
 - Input slew rate is specified in Table 9 on page 21.
 - Definitions for I_{DD} conditions:
 - LOW is defined as $V_{IN} \leq V_{IL(AC)} \text{ MAX}$.
 - HIGH is defined as $V_{IN} \geq V_{IH(AC)} \text{ MIN}$.
 - Stable is defined as inputs remaining at a HIGH or LOW level.
 - Floating is defined as inputs at $V_{REF} = V_{DDQ}/2$.
 - Continuous data is defined as half the DQ signals changing between HIGH and LOW every half clock cycle (twice per clock).
 - Continuous address is defined as half the address signals changing between HIGH and LOW every clock cycle (once per clock).
 - Sequential bank access is defined as the bank address incrementing by one every t_{RC} .
 - Cyclic bank access is defined as the bank address incrementing by one for each command access. For BL = 2 this is every clock, for BL = 4 this is every other clock, and for BL = 8 this is every fourth clock.
 - CS# is HIGH unless a READ, WRITE, AREF, or MRS command is registered. CS# never transitions more than once per clock cycle.
 - I_{DD} parameters are specified with ODT disabled.
 - Tests for AC timing, I_{DD} , and electrical AC and DC characteristics may be conducted at nominal reference/supply voltage levels, but the related specifications and device operations are tested for the full voltage range specified.
 - I_{DD} tests may use a V_{IL} -to- V_{IH} swing of up to 1.5V in the test environment, but input timing is still referenced to V_{REF} (or to the crossing point for CK/CK#), and parameter specifications are tested for the specified AC input levels under normal use conditions. The minimum slew rate for the input signals used to test the device is 2 V/ns in the range between $V_{IL(AC)}$ and $V_{IH(AC)}$.



Electrical Specifications – AC and DC

Absolute Maximum Ratings

Stresses greater than those listed in Table 7 may cause permanent damage to the device. This is a stress rating only, and functional operation of the device at these or any other conditions outside those indicated in the operational sections of this specification is not implied. Exposure to absolute maximum rating conditions for extended periods may affect reliability.

Table 7: Absolute Maximum Ratings

Parameter	Min	Max	Units
I/O voltage	-0.3	$V_{DDQ} + 0.3$	V
Voltage on V_{EXT} supply relative to V_{SS}	-0.3	+2.8	V
Voltage on V_{DD} supply relative to V_{SS}	-0.3	+2.1	V
Voltage on V_{DDQ} supply relative to V_{SS}	-0.3	+2.1	V

AC and DC Operating Conditions

Table 8: DC Electrical Characteristics and Operating Conditions

Note 1 applies to the entire table; Unless otherwise noted: $+0^{\circ}\text{C} \leq T_C \leq +95^{\circ}\text{C}$; $+1.7\text{V} \leq V_{DD} \leq +1.9\text{V}$

Description	Conditions	Symbol	Min	Max	Units	Notes
Supply voltage	-	V_{EXT}	2.38	2.63	V	
Supply voltage	-	V_{DD}	1.7	1.9	V	2
Isolated output buffer supply	-	V_{DDQ}	1.4	V_{DD}	V	2, 3
Reference voltage	-	V_{REF}	$0.49 \times V_{DDQ}$	$0.51 \times V_{DDQ}$	V	4, 5, 6
Termination voltage	-	V_{TT}	$0.95 \times V_{REF}$	$1.05 \times V_{REF}$	V	7, 8
Input high (logic 1) voltage	-	V_{IH}	$V_{REF} + 0.1$	$V_{DDQ} + 0.3$	V	2
Input low (logic 0) voltage	-	V_{IL}	$V_{SSQ} - 0.3$	$V_{REF} - 0.1$	V	2
Output high current	$V_{OH} = V_{DDQ}/2$	I_{OH}	$(V_{DDQ}/2)/(1.15 \times RQ/5)$	$(V_{DDQ}/2)/(0.85 \times RQ/5)$	A	9, 10, 11
Output low current	$V_{OL} = V_{DDQ}/2$	I_{OL}	$(V_{DDQ}/2)/(1.15 \times RQ/5)$	$(V_{DDQ}/2)/(0.85 \times RQ/5)$	A	9, 10, 11
Clock input leakage current	$0\text{V} \leq V_{IN} \leq V_{DD}$	I_{LC}	-5	5	μA	
Input leakage current	$0\text{V} \leq V_{IN} \leq V_{DD}$	I_{LI}	-5	5	μA	
Output leakage current	$0\text{V} \leq V_{IN} \leq V_{DDQ}$	I_{LO}	-5	5	μA	
Reference voltage current	-	I_{REF}	-5	5	μA	

- Notes:
- All voltages referenced to V_{SS} (GND).
 - Overshoot: $V_{IH(AC)} \leq V_{DD} + 0.7\text{V}$ for $t \leq t_{CK}/2$. Undershoot: $V_{IL(AC)} \geq -0.5\text{V}$ for $t \leq t_{CK}/2$. During normal operation, V_{DDQ} must not exceed V_{DD} . Control input signals may not have pulse widths less than $t_{CK}/2$ or operate at frequencies exceeding t_{CK} (MAX).
 - V_{DDQ} can be set to a nominal $1.5\text{V} \pm 0.1\text{V}$ or $1.8\text{V} \pm 0.1\text{V}$ supply.
 - Typically the value of V_{REF} is expected to be $0.5 \times V_{DDQ}$ of the transmitting device. V_{REF} is expected to track variations in V_{DDQ} .
 - Peak-to-peak AC noise on V_{REF} must not exceed $\pm 2\% V_{REF(DC)}$.
 - V_{REF} is expected to equal $V_{DDQ}/2$ of the transmitting device and to track variations in the DC level of the same. Peak-to-peak noise (non-common mode) on V_{REF} may not exceed $\pm 2\%$ of the DC value. Thus, from $V_{DDQ}/2$, V_{REF} is allowed $\pm 2\% V_{DDQ}/2$ for DC error and an additional $\pm 2\% V_{DDQ}/2$ for AC noise. This measurement is to be taken at the nearest V_{REF} bypass capacitor.

7. V_{TT} is expected to be set equal to V_{REF} and must track variations in the DC level of V_{REF} .
8. On-die termination may be selected using mode register bit 9 (see the Mode Register Definition in Nonmultiplexed Address Mode figure). A resistance R_{TT} from each data input signal to the nearest V_{TT} can be enabled.
 $R_{TT} = 125\text{--}185\Omega$ at $95^\circ\text{C } T_C$.
9. I_{OH} and I_{OL} are defined as absolute values and are measured at $V_{DDQ}/2$. I_{OH} flows from the device, I_{OL} flows into the device.
10. If MRS bit A8 is 0, use $R_Q = 250\Omega$ in the equation in lieu of presence of an external impedance matched resistor.
11. For V_{OL} and V_{OH} , refer to the RLD RAM 2 HSPICE or IBIS driver models.

Table 9: Input AC Logic Levels

Notes 1–3 apply to entire table; Unless otherwise noted: $+0^\circ\text{C} \leq T_C \leq +95^\circ\text{C}$; $+1.7\text{V} \leq V_{DD} \leq +1.9\text{V}$

Description	Symbol	Min	Max	Units
Input high (logic 1) voltage	V_{IH}	$V_{REF} + 0.2$	–	V
Input low (logic 0) voltage	V_{IL}	–	$V_{REF} - 0.2$	V

- Notes:
1. All voltages referenced to V_{SS} (GND).
 2. The AC and DC input level specifications are as defined in the HSTL standard (that is, the receiver will effectively switch as a result of the signal crossing the AC input level, and will remain in that state as long as the signal does not ring back above [below] the DC input LOW [HIGH] level).
 3. The minimum slew rate for the input signals used to test the device is 2 V/ns in the range between $V_{IL(AC)}$ and $V_{IH(AC)}$. See illustration below:

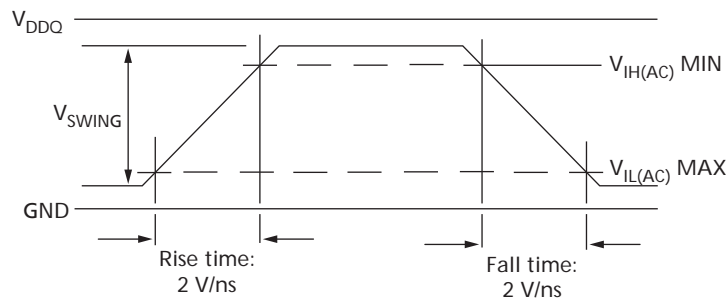

Table 10: Differential Input Clock Operating Conditions

Notes 1–4 apply to the entire table; Unless otherwise noted: $+0^{\circ}\text{C} \leq T_C \leq +95^{\circ}\text{C}$; $+1.7\text{V} \leq V_{DD} \leq +1.9\text{V}$

Parameter/Condition	Symbol	Min	Max	Units	Notes
Clock input voltage level: CK and CK#	$V_{IN(DC)}$	-0.3	$V_{DDQ} + 0.3$	V	
Clock input differential voltage: CK and CK#	$V_{ID(DC)}$	0.2	$V_{DDQ} + 0.6$	V	5
Clock input differential voltage: CK and CK#	$V_{ID(AC)}$	0.4	$V_{DDQ} + 0.6$	V	5
Clock input crossing point voltage: CK and CK#	$V_{IX(AC)}$	$V_{DDQ}/2 - 0.15$	$V_{DDQ}/2 + 0.15$	V	6

- Notes:
1. DKx and DKx# have the same requirements as CK and CK#.
 2. All voltages referenced to V_{SS} (GND).
 3. The CK/CK# input reference level (for timing referenced to CK/CK#) is the point at which CK and CK# cross. The input reference level for signals other than CK/CK# is V_{REF} .
 4. CK and CK# input slew rate must be ≥ 2 V/ns (≥ 4 V/ns if measured differentially).
 5. V_{ID} is the magnitude of the difference between the input level on CK and the input level on CK#.
 6. The value of V_{IX} is expected to equal $V_{DDQ}/2$ of the transmitting device and must track variations in the DC level of the same.

Figure 7: Clock Input

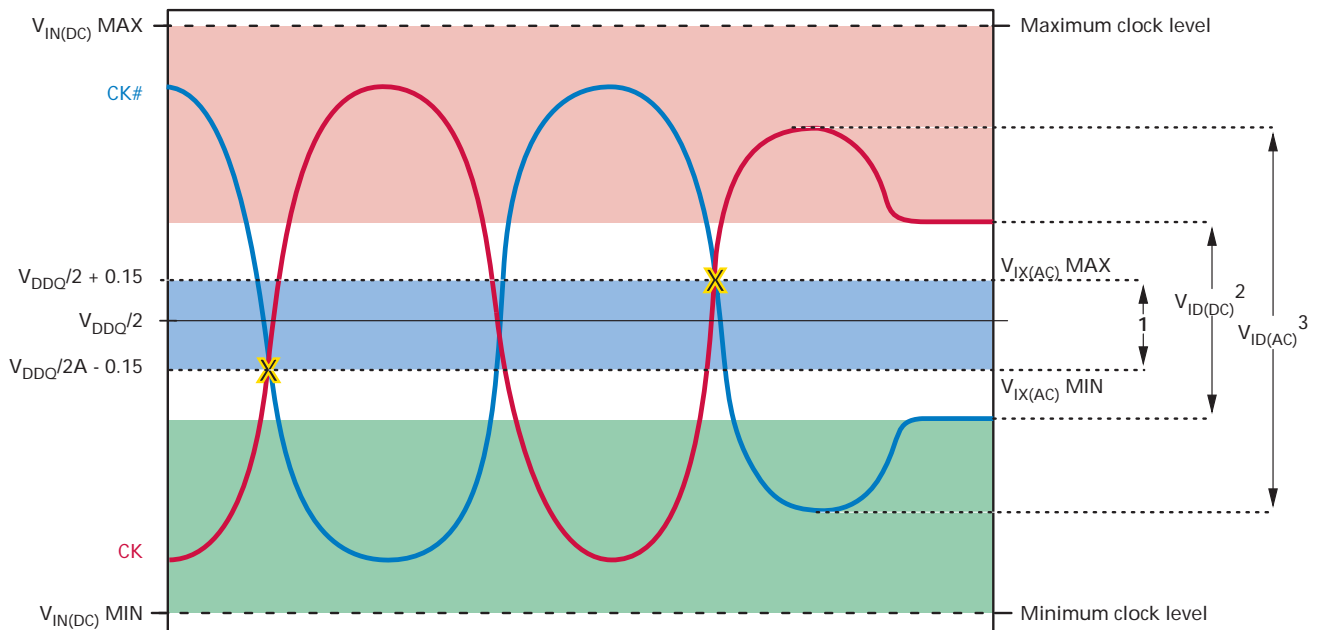

- Notes:
1. CK and CK# must cross within this region.
 2. CK and CK# must meet at least $V_{ID(DC)}$ MIN when static and centered around $V_{DDQ}/2$.
 3. Minimum peak-to-peak swing.
 4. It is a violation to tristate CK and CK# after the part is initialized.

Input Slew Rate Derating

Table 11 on page 24 and Table 12 on page 25 define the address, command, and data setup and hold derating values. These values are added to the default $t_{AS}/t_{CS}/t_{DS}$ and $t_{AH}/t_{CH}/t_{DH}$ specifications when the slew rate of any of these input signals is less than the 2 V/ns the nominal setup and hold specifications are based upon.

To determine the setup and hold time needed for a given slew rate, add the t_{AS}/t_{CS} default specification to the “ $t_{AS}/t_{CS} V_{REF}$ to CK/CK# Crossing” and the t_{AH}/t_{CH} default specification to the “ t_{AH}/t_{CH} CK/CK# Crossing to V_{REF} ” derated values on Table 11. The derated data setup and hold values can be determined in a like manner using the “ $t_{DS} V_{REF}$ to CK/CK# Crossing” and “ t_{DH} to CK/CK# Crossing to V_{REF} ” values on Table 12. The derating values on Table 11 and Table 12 apply to all speed grades.

The setup times on Table 11 and Table 12 represent a rising signal. In this case, the time from which the rising signal crosses $V_{IH(AC)}$ MIN to the CK/CK# cross point is static and must be maintained across all slew rates. The derated setup timing represents the point at which the rising signal crosses $V_{REF(DC)}$ to the CK/CK# cross point. This derated value is calculated by determining the time needed to maintain the given slew rate and the delta between $V_{IH(AC)}$ MIN and the CK/CK# cross point. The setup values in Table 11 and Table 12 are also valid for falling signals (with respect to $V_{IL[AC]}$ MAX and the CK/CK# cross point).

The hold times in Table 11 and Table 12 represent falling signals. In this case, the time from the CK/CK# cross point to when the signal crosses $V_{IH(DC)}$ MIN is static and must be maintained across all slew rates. The derated hold timing represents the delta between the CK/CK# cross point to when the falling signal crosses $V_{REF(DC)}$. This derated value is calculated by determining the time needed to maintain the given slew rate and the delta between the CK/CK# cross point and $V_{IH(DC)}$. The hold values in Table 11 and Table 12 are also valid for rising signals (with respect to $V_{IL[DC]}$ MAX and the CK and CK# cross point).

Note: The above descriptions also pertain to data setup and hold derating when CK/CK# are replaced with DK/DK#.



Table 11: Address and Command Setup and Hold Derating Values

Command/ Address Slew Rate (V/ns)	t_{AS}/t_{CS} V_{REF} to CK/CK# Crossing	t_{AS}/t_{CS} $V_{IH(AC)}$ MIN to CK/CK# Crossing	t_{AH}/t_{CH} CK/CK# Crossing to V_{REF}	t_{AH}/t_{CH} CK/CK# Crossing to $V_{IH(DC)}$ MIN	Units
CK, CK# Differential Slew Rate: 2.0 V/ns					
2.0	0	-100	0	-50	ps
1.9	5	-100	3	-50	ps
1.8	11	-100	6	-50	ps
1.7	18	-100	9	-50	ps
1.6	25	-100	13	-50	ps
1.5	33	-100	17	-50	ps
1.4	43	-100	22	-50	ps
1.3	54	-100	27	-50	ps
1.2	67	-100	34	-50	ps
1.1	82	-100	41	-50	ps
1.0	100	-100	50	-50	ps
CK, CK# Differential Slew Rate: 1.5 V/ns					
2.0	30	-70	30	-20	ps
1.9	35	-70	33	-20	ps
1.8	41	-70	36	-20	ps
1.7	48	-70	39	-20	ps
1.6	55	-70	43	-20	ps
1.5	63	-70	47	-20	ps
1.4	73	-70	52	-20	ps
1.3	84	-70	57	-20	ps
1.2	97	-70	64	-20	ps
1.1	112	-70	71	-20	ps
1.0	130	-70	80	-20	ps
CK, CK# Differential Slew Rate: 1.0 V/ns					
2.0	60	-40	60	10	ps
1.9	65	-40	63	10	ps
1.8	71	-40	66	10	ps
1.7	78	-40	69	10	ps
1.6	85	-40	73	10	ps
1.5	93	-40	77	10	ps
1.4	103	-40	82	10	ps
1.3	114	-40	87	10	ps
1.2	127	-40	94	10	ps
1.1	142	-40	101	10	ps
1.0	160	-40	110	10	ps



Table 12: Data Setup and Hold Derating Values

Data Slew Rate (V/ns)	$t_{DS} V_{REF}$ to CK/CK# Crossing	$t_{DS} V_{IH(AC)}$ MIN to CK/CK# Crossing	t_{DH} CK/CK# Crossing to V_{REF}	t_{DH} CK/CK# Crossing to $V_{IH(DC)}$ MIN	Units
DK, DK# Differential Slew Rate: 2.0 V/ns					
2.0	0	-100	0	-50	ps
1.9	5	-100	3	-50	ps
1.8	11	-100	6	-50	ps
1.7	18	-100	9	-50	ps
1.6	25	-100	13	-50	ps
1.5	33	-100	17	-50	ps
1.4	43	-100	22	-50	ps
1.3	54	-100	27	-50	ps
1.2	67	-100	34	-50	ps
1.1	82	-100	41	-50	ps
1.0	100	-100	50	-50	ps
DK, DK# Differential Slew Rate: 1.5 V/ns					
2.0	30	-70	30	-20	ps
1.9	35	-70	33	-20	ps
1.8	41	-70	36	-20	ps
1.7	48	-70	39	-20	ps
1.6	55	-70	43	-20	ps
1.5	63	-70	47	-20	ps
1.4	73	-70	52	-20	ps
1.3	84	-70	57	-20	ps
1.2	97	-70	64	-20	ps
1.1	112	-70	71	-20	ps
1.0	130	-70	80	-20	ps
DK, DK# Differential Slew Rate: 1.0 V/ns					
2.0	60	-40	60	10	ps
1.9	65	-40	63	10	ps
1.8	71	-40	66	10	ps
1.7	78	-40	69	10	ps
1.6	85	-40	73	10	ps
1.5	93	-40	77	10	ps
1.4	103	-40	82	10	ps
1.3	114	-40	87	10	ps
1.2	127	-40	94	10	ps
1.1	142	-40	101	10	ps
1.0	160	-40	110	10	ps

Figure 8: Nominal $t_{AS}/t_{CS}/t_{DS}$ and $t_{AH}/t_{CH}/t_{DH}$ Slew Rate

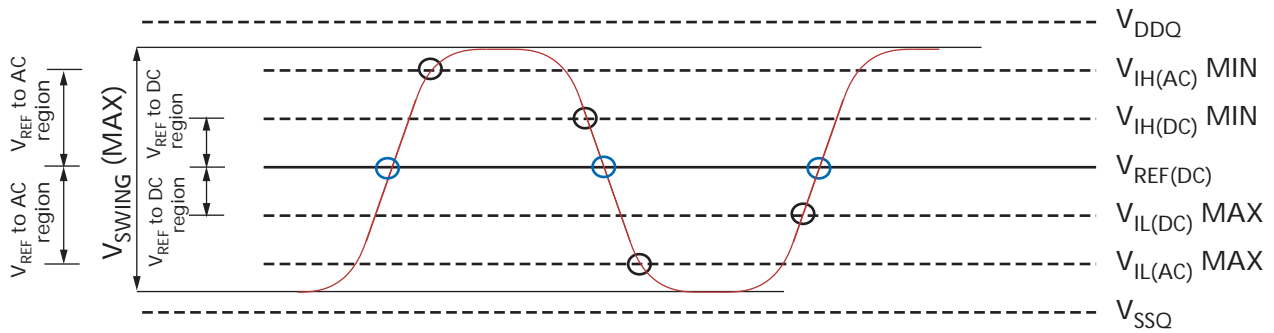

Table 13: Capacitance – μ BGA

Notes 1–2 apply to entire table

Description	Symbol	Conditions	Min	Max	Units
Address/control input capacitance	C_I	$T_A = 25^\circ\text{C}; f = 100 \text{ MHz}$ $V_{DD} = V_{DDQ} = 1.8\text{V}$	1.0	2.0	pF
Input/output capacitance (DQ, DM, and QK/QK#)	C_O		3.0	4.5	pF
Clock capacitance (CK/CK#, and DK/DK#)	C_{CK}		1.5	2.5	pF
JTAG pins	C_{JTAG}		1.5	4.5	pF

- Notes: 1. Capacitance is not tested on ZQ pin.
2. JTAG pins are tested at 50 MHz.



Table 14: AC Electrical Characteristics: -18, -25E, -25, -33, -5
Notes 1–4 (page 29) apply to the entire table

Description	Symbol	-18		-25E		-25		-33		-5		Units	Notes
		Min	Max	Min	Max	Min	Max	Min	Max	Min	Max		
Clock													
Input clock cycle time	t _{CK}	1.875	5.7	2.5	5.7	2.5	5.7	3.3	5.7	5.0	5.7	ns	
Input data clock cycle time	t _{DK}	t _{CK}		t _{CK}		t _{CK}		t _{CK}		t _{CK}		ns	
Clock jitter: period	t _{JITPER}	-100	100	-150	150	-150	150	-200	200	-250	250	ps	5, 6
Clock jitter: cycle-to-cycle	t _{JITCC}		200		300		300		400		500	ps	
Clock HIGH time	t _{CKH} , t _{DKH}	0.45	0.55	0.45	0.55	0.45	0.55	0.45	0.55	0.45	0.55	t _{CK}	
Clock LOW time	t _{CKL} , t _{DKL}	0.45	0.55	0.45	0.55	0.45	0.55	0.45	0.55	0.45	0.55	t _{CK}	
Clock to input data clock	t _{CKDK}	-0.3	0.3	-0.45	0.5	-0.3	0.5	-0.3	1.0	-0.3	1.5	ns	
Mode register set cycle time to any command	t _{MRSC}	6	-	6	-	6	-	6	-	6	-	t _{CK}	
Setup Times													
Address/ command and input setup time	t _{AS} /t _{CS}	0.3	-	0.4	-	0.4	-	0.5	-	0.8	-	ns	
Data-in and data mask to DK setup time	t _{DS}	0.17	-	0.25	-	0.25	-	0.3	-	0.4	-	ns	
Hold Times													
Address/ command and input hold time	t _{AH} /t _{CH}	0.3	-	0.4	-	0.4	-	0.5	-	0.8	-	ns	
Data-in and data mask to DK hold time	t _{DH}	0.17	-	0.25	-	0.25	-	0.3	-	0.4	-	ns	
Data and Data Strobe													
Output data clock HIGH time	t _{QKH}	0.9	1.1	0.9	1.1	0.9	1.1	0.9	1.1	0.9	1.1	t _{CKH}	
Output data clock LOW time	t _{QKL}	0.9	1.1	0.9	1.1	0.9	1.1	0.9	1.1	0.9	1.1	t _{CKL}	
Half-clock period	t _{QHP}	MIN (t _{QKH} , t _{QKL})	-	MIN (t _{QKH} , t _{QKL})	-	MIN (t _{QKH} , t _{QKL})	-	MIN (t _{QKH} , t _{QKL})	-	MIN (t _{QKH} , t _{QKL})	-		
QK edge to clock edge skew	t _{CKQK}	-0.2	0.2	-0.25	0.25	-0.25	0.25	-0.3	0.3	-0.5	0.5	ns	
QK edge to output data edge	t _{QKQ0} , t _{QKQ1}	-0.12	0.12	-0.2	0.2	-0.2	0.2	-0.25	0.25	-0.3	0.3	ns	7
QK edge to any output data edge	t _{QKQ}	-0.22	0.22	-0.3	0.3	-0.3	0.3	-0.35	0.35	-0.4	0.4	ns	8



Table 14: AC Electrical Characteristics: -18, -25E, -25, -33, -5 (continued)

Notes 1–4 (page 29) apply to the entire table

Description	Symbol	-18		-25E		-25		-33		-5		Units	Notes
		Min	Max	Min	Max	Min	Max	Min	Max	Min	Max		
QK edge to QVLD	^t QKVLD	-0.22	0.22	-0.3	0.3	-0.3	0.3	-0.35	0.35	-0.4	0.4	ns	
Data valid window	^t DVW	^t QHP - (^t QKQx [MAX] + ^t QKQx [MIN])	-	^t QHP - (^t QKQx [MAX] + ^t QKQx [MIN])	-	^t QHP - (^t QKQx [MAX] + ^t QKQx [MIN])	-	^t QHP - (^t QKQx [MAX] + ^t QKQx [MIN])	-	^t QHP - (^t QKQx [MAX] + ^t QKQx [MIN])	-		
Refresh													
Average periodic refresh interval	^t REFI	-	0.49	-	0.49	-	0.49	-	0.49	-	0.49	μs	9

Notes

1. All timing parameters are measured relative to the crossing point of CK/CK#, DK/DK# and to the crossing point with V_{REF} of the command, address, and data signals.
2. Outputs measured with equivalent load:

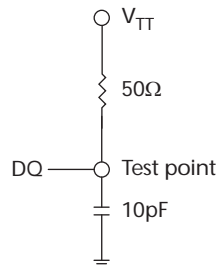

3. Tests for AC timing, I_{DD} , and electrical AC and DC characteristics may be conducted at nominal reference/supply voltage levels, but the related specifications and device operations are tested for the full voltage range specified.
4. AC timing may use a V_{IL} -to- V_{IH} swing of up to 1.5V in the test environment, but input timing is still referenced to V_{REF} (or to the crossing point for CK/CK#), and parameter specifications are tested for the specified AC input levels under normal use conditions. The minimum slew rate for the input signals used to test the device is 2 V/ns in the range between $V_{IL(AC)}$ and $V_{IH(AC)}$.
5. Clock phase jitter is the variance from clock rising edge to the next expected clock rising edge.
6. Frequency drift is not allowed.
7. t_{QKQ0} is referenced to DQ0–DQ17 for the x36 configuration and DQ0–DQ8 for the x18 configuration. t_{QKQ1} is referenced to DQ18–DQ35 for the x36 configuration and DQ9–DQ17 for the x18 configuration.
8. t_{QKQ} takes into account the skew between any QKx and any Q.
9. To improve efficiency, eight AREF commands (one for each bank) can be posted to the RLD RAM on consecutive cycles at periodic intervals of 3.90μs.

Temperature and Thermal Impedance

It is imperative that the RLDRAM device's temperature specifications, shown in Table 15, are maintained in order to ensure that the junction temperature is in the proper operating range to meet data sheet specifications. An important step in maintaining the proper junction temperature is using the device's thermal impedances correctly. The thermal impedances are listed for the available packages.

Using thermal impedances incorrectly can produce significant errors. Read Micron technical note TN-00-08, "Thermal Applications" prior to using the thermal impedances listed in Table 15. For designs that are expected to last several years and require the flexibility to use several DRAM die shrinks, consider using final target theta values (rather than existing values) to account for increased thermal impedances from the die size reduction.

The RLDRAM device's safe junction temperature range can be maintained when the T_C specification is not exceeded. In applications where the device's ambient temperature is too high, use of forced air and/or heat sinks may be required in order to satisfy the case temperature specifications.

Table 15: Temperature Limits

Parameter		Symbol	Min	Max	Units	Notes
Storage temperature		T_{STG}	-55	+150	°C	1
Reliability junction temperature	Commercial	T_J	-	+110	°C	2
	Industrial		-	+110	°C	2
Operating junction temperature	Commercial	T_J	0	+100	°C	3
	Industrial		-40	+100	°C	3
Operating case temperature	Commercial	T_C	0	+95	°C	4, 5
	Industrial		-40	+95	°C	4, 5, 6

- Notes:
1. MAX storage case temperature; T_{STG} is measured in the center of the package, as shown in Figure 9 on page 31. This case temperature limit can be exceeded briefly during package reflow, as noted in Micron technical note TN-00-15.
 2. Temperatures greater than 110°C may cause permanent damage to the device. This is a stress rating only and functional operation of the device at or above this is not implied. Exposure to absolute maximum rating conditions for extended periods may affect the reliability of the part.
 3. Junction temperature depends upon package type, cycle time, loading, ambient temperature, and airflow.
 4. MAX operating case temperature; T_C is measured in the center of the package, as shown in Figure 9 on page 31.
 5. Device functionality is not guaranteed if the device exceeds maximum T_C during operation.
 6. Both temperature specifications must be satisfied.

Table 16: Thermal Impedance

Package	Substrate	θ_{JA} ($^{\circ}C/W$) Airflow = 0m/s	θ_{JA} ($^{\circ}C/W$) Airflow = 1m/s	θ_{JA} ($^{\circ}C/W$) Airflow = 2m/s	θ_{JB} ($^{\circ}C/W$)	θ_{JC} ($^{\circ}C/W$)
Rev. A die	2-layer	41.2	29.1	25.3	14.3	2.27
	4-layer	28.2	21.9	19.9	13.6	
Rev. B die	2-layer	53.7	42.0	37.7	28.9	3.9
	4-layer	34.1	28.9	27.1	21.9	

Notes: Thermal impedance data is based on a number of samples from multiple lots and should be viewed as a typical number.

Figure 9: Example Temperature Test Point Location

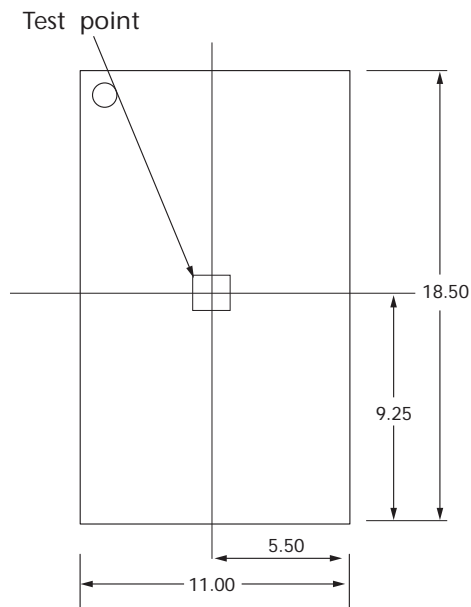

Commands

The following table provides descriptions of the valid commands of the RLD RAM. All input states or sequences not shown are illegal or reserved. All command and address inputs must meet setup and hold times around the rising edge of CK.

Table 17: Description of Commands

Command	Description	Notes
DSEL/NOP	The NOP command is used to perform a no operation to the RLD RAM, which essentially deselects the chip. Use the NOP command to prevent unwanted commands from being registered during idle or wait states. Operations already in progress are not affected. Output values depend on command history.	1
MRS	The mode register is set via the address inputs A0–A17. See Figure 10 on page 34 for further information. The MRS command can only be issued when all banks are idle and no other operation is in progress.	
READ	The READ command is used to initiate a burst read access to a bank. The value on the BA0–BA2 inputs selects the bank, and the address provided on inputs A0–A _n selects the data location within the bank.	2
WRITE	The WRITE command is used to initiate a burst write access to a bank. The value on the BA0–BA2 inputs selects the bank, and the address provided on inputs A0–A _n selects the data location within the bank. Input data appearing on the DQ is written to the memory array subject to the DM input logic level appearing coincident with the data. If the DM signal is registered LOW, the corresponding data will be written to memory. If the DM signal is registered HIGH, the corresponding data inputs will be ignored (that is, this part of the data word will not be written).	2
AREF	The AREF command is used during normal operation of the RLD RAM to refresh the memory content of a bank. The command is nonpersistent, so it must be issued each time a refresh is required. The value on the BA0–BA2 inputs selects the bank. The refresh address is generated by an internal refresh controller, effectively making each address bit a “Don’t Care” during the AREF command. See “AUTO REFRESH (AREF)” on page 41 for more details.	

- Notes: 1. When the chip is deselected, internal NOP commands are generated and no commands are accepted.
2. $n = 20$.

Table 18: Command Table

Notes 1–2 apply to the entire table

Operation	Code	CS#	WE#	REF#	A0–A _n ²	BA0–BA2	Notes
Device Deselect/no operation	DSEL/NOP	H	X	X	X	X	
MRS	MRS	L	L	L	OPCODE	X	3
READ	READ	L	H	H	A	BA	4
WRITE	WRITE	L	L	H	A	BA	4
AUTO REFRESH	AREF	L	H	L	X	BA	

- Notes: 1. X = “Don’t Care;” H = logic HIGH; L = logic LOW; A = valid address; BA = valid bank address.
2. $n = 20$.
3. Only A0–A17 are used for the MRS command.
4. Address width varies with burst length; see the Address Widths at Different Burst Lengths table for details.

MODE REGISTER SET (MRS)

The mode register set stores the data for controlling the operating modes of the memory. It programs the RLD RAM configuration, burst length, test mode, and I/O options. During an MRS command, the address inputs A0–A17 are sampled and stored in the mode register. After issuing a valid MRS command, ^tMRSC must be met before any command can be issued to the RLD RAM. This statement does not apply to the consecutive MRS commands needed for internal logic reset during the initialization routine. The MRS command can only be issued when all banks are idle and no other operation is in progress.

Note: The data written by the prior burst length is not guaranteed to be accurate when the burst length of the device is changed.

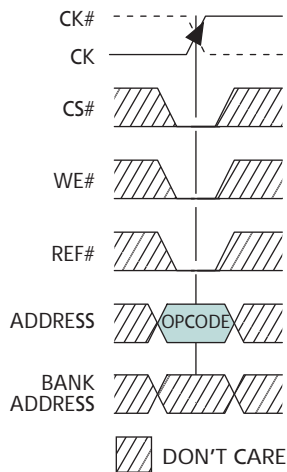
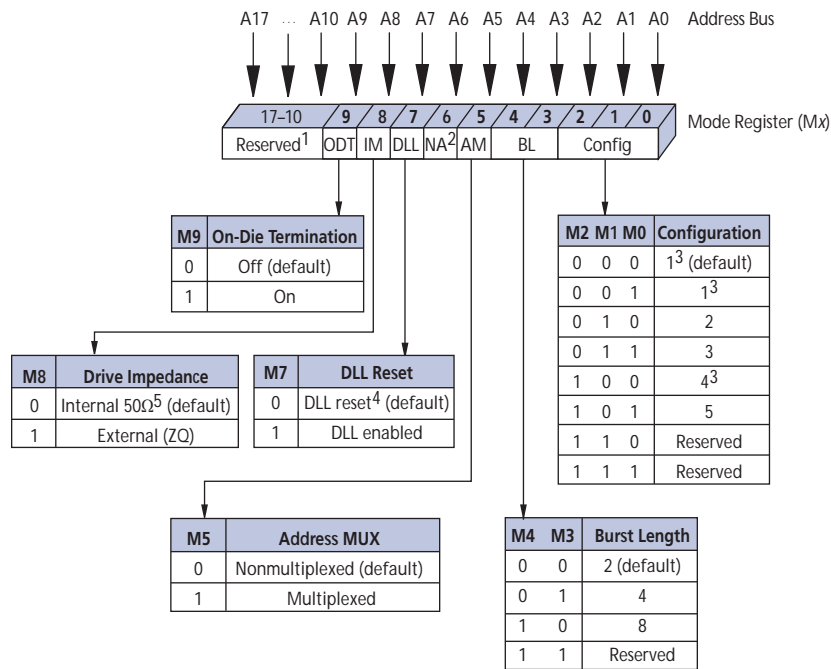

Figure 10: Mode Register Definition in Nonmultiplexed Address Mode



- Notes:
1. A10–A17 must be set to zero; A18–An = “Don’t Care.”
 2. A6 not used in MRS.
 3. BL = 8 is not available.
 4. DLL RESET turns the DLL off.
 5. ±30% temperature variation.

Configuration Tables

Table 19 shows the different configurations that can be programmed into the mode register. The WRITE latency is equal to the READ latency plus one in each configuration in order to maximize data bus utilization. Bits M0, M1, and M2 are used to select the configuration during the MRS command.

Table 19: Cycle Time and READ/WRITE Latency Configuration Table

Notes 1 apply to the entire table

Parameter	Configuration					Units
	1 ²	2	3	4 ^{2, 3}	5	
t _{RC}	4	6	8	3	5	t _{CK}
t _{RL}	4	6	8	3	5	t _{CK}
t _{WL}	5	7	9	4	6	t _{CK}
Valid frequency range	266–175	400–175	533–175	200–175	333–175	MHz

- Notes:
1. t_{RC} < 20ns in any configuration only available with -25E and -18 speed grades.
 2. BL = 8 is not available.
 3. The minimum t_{RC} is typically 3 cycles, except in the case of a WRITE followed by a READ to the same bank. In this instance the minimum t_{RC} is 4 cycles.

Burst Length (BL)

Burst length is defined by M3 and M4 of the mode register. Read and write accesses to the RLD RAM are burst-oriented, with the burst length being programmable to 2, 4, or 8. Figure 11 on page 36 illustrates the different burst lengths with respect to a READ command. Changes in the burst length affect the width of the address bus (see the Address Widths at Different Burst Lengths table for details).

Note: The data written by the prior burst length is not guaranteed to be accurate when the burst length of the device is changed.

Figure 11: Read Burst Lengths

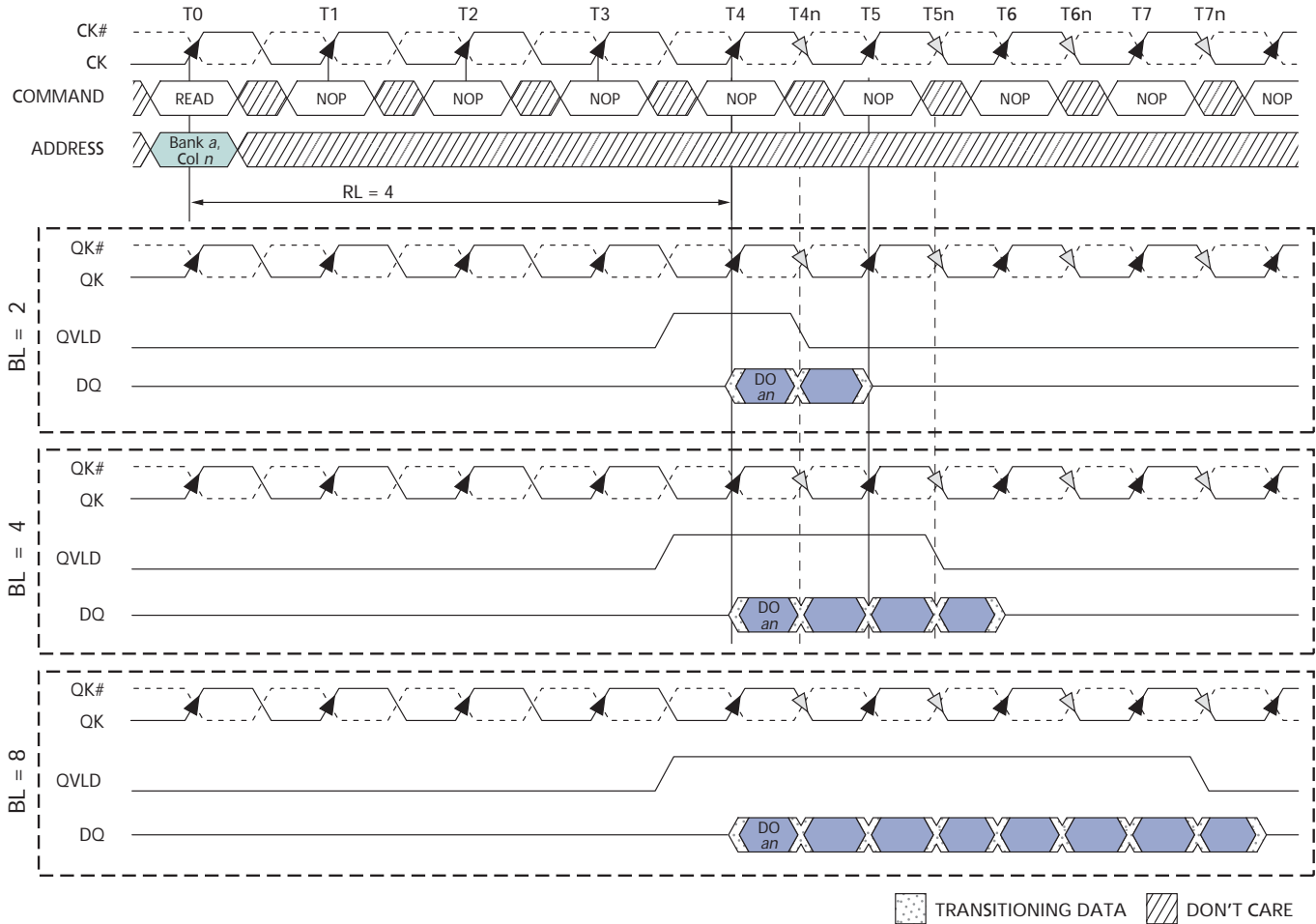

- Notes:
1. DO *an* = data-out from bank *a* and address *an*.
 2. Subsequent elements of data-out appear after DO *n*.
 3. Shown with nominal t_{CKQK} .

Table 20: Address Widths at Different Burst Lengths

Burst Length			
	x9	x18	x36
2	A0-A20	A0-A19	A0-A18
4	A0-A19	A0-A18	A0-A17
8	A0-A18	A0-A17	A0-A16 ¹

- Notes:
1. Only available on Rev B die.

Address Multiplexing

Although the RLD RAM has the ability to operate with an SRAM interface by accepting the entire address in one clock, an option in the mode register can be set so that it functions with multiplexed addresses, similar to a traditional DRAM. In multiplexed address mode, the address can be provided to the RLD RAM in two parts that are latched into the memory with two consecutive rising clock edges. This provides the advantage of only

needing a maximum of 11 address balls to control the RLD RAM, reducing the number of signals on the controller side. The data bus efficiency in continuous burst mode is only affected when using the BL = 2 setting since the device requires two clocks to read and write the data. The bank addresses are delivered to the RLD RAM at the same time as the WRITE and READ command and the first address part, Ax. The Address Mapping in Multiplexed Address Mode table shows the addresses needed for both the first and second rising clock edges (Ax and Ay, respectively). The AREF command does not require an address on the second rising clock edge, as only the bank address is needed during this command. Because of this, AREF commands may be issued on consecutive clocks.

The multiplexed address option is available by setting bit M5 to “1” in the mode register. Once this bit is set, the READ, WRITE, and MRS commands follow the format described in the Command Description in Multiplexed Address Mode table. Further information on operation with multiplexed addresses can be seen in the Multiplexed Address Mode section.

DLL RESET

DLL RESET is selected with bit M7 of the mode register as is shown in the Mode Register Definition in Nonmultiplexed Address Mode figure. The default setting for this option is LOW, whereby the DLL is disabled. Once M7 is set HIGH, 1,024 cycles (5 μ s at 200 MHz) are needed before a READ command can be issued. This time allows the internal clock to be synchronized with the external clock. Failing to wait for synchronization to occur may result in a violation of the t_{CKQK} parameter. A reset of the DLL is necessary if t_{CK} or V_{DD} is changed after the DLL has already been enabled. To reset the DLL, an MRS command must be issued where M7 is set LOW. After waiting t_{MRSC} , a subsequent MRS command should be issued whereby M7 goes HIGH. 1,024 clock cycles are then needed before a READ command is issued.

Drive Impedance Matching

The RLD RAM 2 is equipped with programmable impedance output buffers. This option is selected by setting bit M8 HIGH during the MRS command. The purpose of the programmable impedance output buffers is to allow the user to match the driver impedance to the system. To adjust the impedance, an external precision resistor (RQ) is connected between the ZQ ball and Vss. The value of the resistor must be five times the desired impedance. For example, a 300 Ω resistor is required for an output impedance of 60 Ω . The range of RQ is 125–300 Ω , which guarantees output impedance in the range of 25–60 Ω (within 15%).

Output impedance updates may be required because over time variations may occur in supply voltage and temperature. When the external drive impedance is enabled in the MRS, the device will periodically sample the value of RQ. An impedance update is transparent to the system and does not affect device operation. All data sheet timing and current specifications are met during an update.

When bit M8 is set LOW during the MRS command, the RLD RAM provides an internal impedance at the output buffer of 50 Ω (\pm 30% with temperature variation). This impedance is also periodically sampled and adjusted to compensate for variation in supply voltage and temperature.

On-Die Termination (ODT)

ODT is enabled by setting M9 to “1” during an MRS command. With ODT on, the DQs and DM are terminated to V_{TT} with a resistance R_{TT} . The command, address, QVLD, and clock signals are not terminated. Figure 12 on page 38 shows the equivalent circuit of a DQ receiver with ODT. The ODT function is dynamically switched off when a DQ begins to drive after a READ command is issued. Similarly, ODT is designed to switch on at the DQs after the RLD RAM has issued the last piece of data. The DM pin will always be terminated. See section entitled "Operations" on page 42 for relevant timing diagrams.

Table 21: On-Die Termination DC Parameters

Description	Symbol	Min	Max	Units	Notes
Termination voltage	V_{TT}	$0.95 \times V_{REF}$	$1.05 \times V_{REF}$	V	1, 2
On-die termination	R_{TT}	125	185	Ω	3

- Notes:
1. All voltages referenced to V_{SS} (GND).
 2. V_{TT} is expected to be set equal to V_{REF} and must track variations in the DC level of V_{REF} .
 3. The R_{TT} value is measured at 95°C T_C .

Figure 12: On-Die Termination-Equivalent Circuit

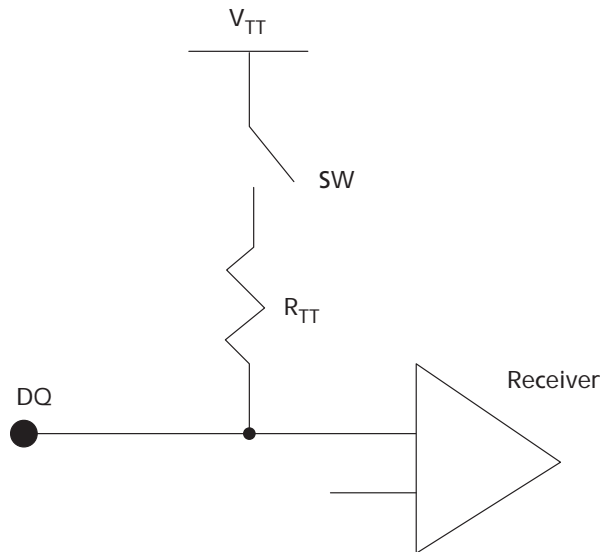

WRITE

Write accesses are initiated with a WRITE command, as shown in Figure 13. The address needs to be provided during the WRITE command.

During WRITE commands, data will be registered at both edges of DK according to the programmed burst length (BL). The RLD RAM operates with a WRITE latency (WL) that is one cycle longer than the programmed READ latency (RL + 1), with the first valid data registered at the first rising DK edge WL cycles after the WRITE command.

Any WRITE burst may be followed by a subsequent READ command (assuming t_{RC} is met). To avoid external data bus contention, at least one NOP command is needed between the WRITE and READ commands. Figure 20 on page 47 and Figure 21 on page 48 illustrate the timing requirements for a WRITE followed by a READ where one and two intermediary NOPS are required, respectively.

Setup and hold times for incoming DQ relative to the DK edges are specified as t_{DS} and t_{DH} . The input data is masked if the corresponding DM signal is HIGH. The setup and hold times for the DM signal are also t_{DS} and t_{DH} .

Figure 13: WRITE Command

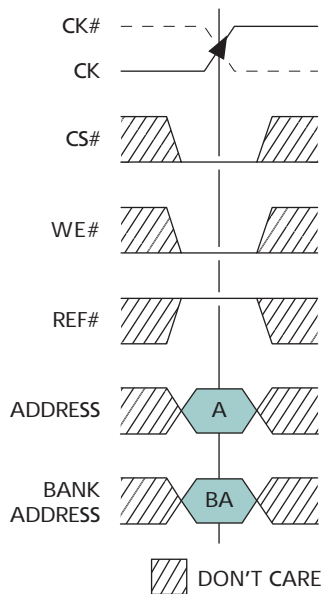

READ

Read accesses are initiated with a READ command, as shown in Figure 14. Addresses are provided with the READ command.

During READ bursts, the memory device drives the read data so it is edge-aligned with the QKx signals. After a programmable READ latency, data is available at the outputs. One half clock cycle prior to valid data on the read bus, the data valid signal, QVLD, transitions from LOW to HIGH. QVLD is also edge-aligned with the QKx signals.

The skew between QK and the crossing point of CK is specified as t_{CKQK} . t_{QKQ0} is the skew between QK0 and the last valid data edge generated at the DQ signals associated with QK0 (t_{QKQ0} is referenced to DQ0–DQ17 for the x36 configuration and DQ0–DQ8 for the x18 configuration). t_{QKQ1} is the skew between QK1 and the last valid data edge generated at the DQ signals associated with QK1 (t_{QKQ1} is referenced to DQ18–DQ35 for the x36 and DQ9–DQ17 for the x18 configuration). t_{QKQx} is derived at each QKx clock edge and is not cumulative over time. t_{QKQ} is defined as the skew between either QK differential pair and any output data edge.

After completion of a burst, assuming no other commands have been initiated, output data (DQ) will go High-Z. The QVLD signal transitions LOW on the last bit of the READ burst. Note that if CK/CK# violates the V_{ID(DC)} specification while a READ burst is occurring, QVLD will remain HIGH until a dummy READ command is issued. The QK clocks are free-running and will continue to cycle after the read burst is complete. Back-to-back READ commands are possible, producing a continuous flow of output data.

The data valid window is derived from each QK transition and is defined as:

$t_{QHP} - (t_{QKQ} [MAX] + |t_{QKQ} [MIN]|)$. See Figures 27–29 for illustration.

Any READ burst may be followed by a subsequent WRITE command. Figure 26 on page 52 illustrate the timing requirements for a READ followed by a WRITE. Some systems having long line lengths or severe skews may need additional idle cycles inserted between READ and WRITE commands to prevent data bus contention.

Figure 14: READ Command

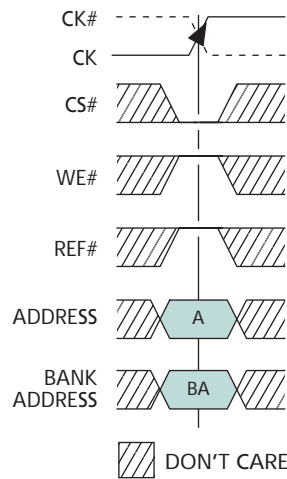

AUTO REFRESH (AREF)

AREF is used to perform a REFRESH cycle on one row in a specific bank. Because the row addresses are generated by an internal refresh counter for each bank, the external address balls are “Don’t Care.” The bank addresses must be provided during the AREF command. The bank address is needed during the AREF command so refreshing of the part can effectively be hidden behind commands to other banks. The delay between the AREF command and a subsequent command to the same bank must be at least t_{RC} .

Within a period of 32ms (t_{REF}), the entire device must be refreshed. For the 288Mb device, the RLD RAM requires 64K cycles at an average periodic interval of 0.49µs MAX (actual periodic refresh interval is 32ms/8K rows/8 banks = 0.488µs). To improve efficiency, eight AREF commands (one for each bank) can be posted to the RLD RAM at periodic intervals of 3.9µs (32ms/8K rows = 3.90µs). Figure 30 on page 56 illustrates an example of a refresh sequence.

Figure 15: AUTO REFRESH Command

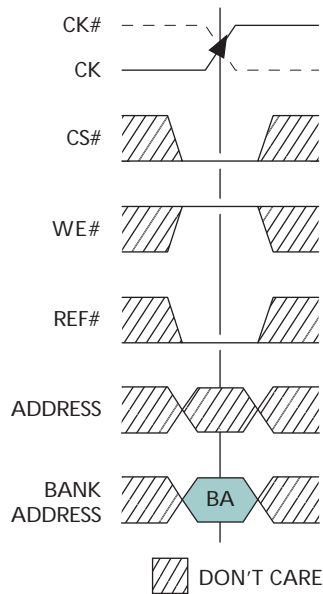

Operations

INITIALIZATION

The RLD RAM must be powered up and initialized in a predefined manner. Operational procedures other than those specified may result in undefined operations or permanent damage to the device.

The following sequence is used for power-up:

1. Apply power (V_{EXT} , V_{DD} , V_{DDQ} , V_{REF} , V_{TT}) and start clock as soon as the supply voltages are stable. Apply V_{DD} and V_{EXT} before or at the same time as V_{DDQ} .¹ Apply V_{DDQ} before or at the same time as V_{REF} and V_{TT} . Although there is no timing relation between V_{EXT} and V_{DD} , the chip starts the power-up sequence only after both voltages approach their nominal levels. CK/CK# must meet $V_{ID(DC)}$ prior to being applied.² Apply NOP conditions to command pins. Ensuring CK/CK# meet $V_{ID(DC)}$ while applying NOP conditions to the command pins guarantees that the RLD RAM will not receive unwanted commands during initialization.
2. Maintain stable conditions for 200 μ s (MIN).
3. Issue at least three consecutive MRS commands: two or more dummies plus one valid MRS. The purpose of these consecutive MRS commands is to internally reset the logic of the RLD RAM. Note that t_{MRSC} does not need to be met between these consecutive commands. It is recommended that all address pins are held LOW during the dummy MRS commands.
4. t_{MRSC} after the valid MRS, an AUTO REFRESH command to all 8 banks (along with 1,024 NOP commands) must be issued prior to normal operation. The sequence of the eight AUTO REFRESH commands (with respect to the 1,024 NOP commands) does not matter. As is required for any operation, t_{RC} must be met between an AUTO REFRESH command and a subsequent VALID command to the same bank. Note that older versions of the data sheet required each of these AUTO REFRESH commands be separated by 2,048 NOP commands. This properly initializes the RLD RAM but is no longer required.

- Notes:**
1. It is possible to apply V_{DDQ} before V_{DD} . However, when doing this, the DQs, DM, and all other pins with an output driver, will go HIGH instead of tri-stating. These pins will remain HIGH until V_{DD} is at the same level as V_{DDQ} . Care should be taken to avoid bus conflicts during this period.
 2. If $V_{ID(DC)}$ on CK/CK# can not be met prior to being applied to the RLD RAM, placing a large external resistor from CS# to V_{DD} is a viable option for ensuring the command bus does not receive unwanted commands during this unspecified state.

Figure 16: Power-Up/Initialization Sequence

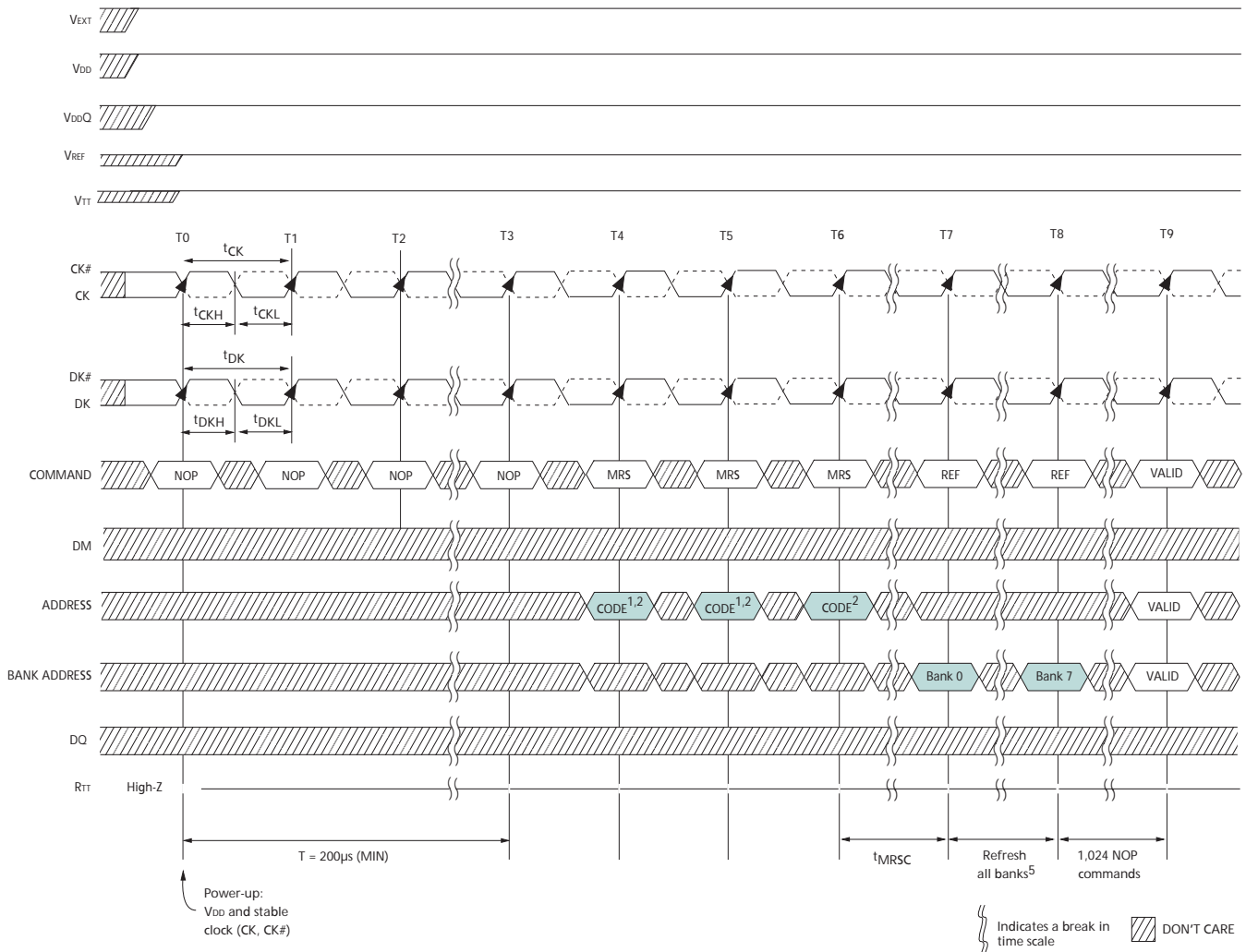

- Notes:
1. Recommend all address pins held LOW during dummy MRS commands.
 2. A10-A17 must be LOW.
 3. DLL must be reset if t_{CK} or V_{DD} are changed.
 4. CK and CK# must be separated at all times to prevent bogus commands from being issued.
 5. The sequence of the eight AUTO REFRESH commands (with respect to the 1,024 NOP commands) does not matter. As is required for any operation, t_{RC} must be met between an AUTO REFRESH command and a subsequent VALID command to the same bank.

Figure 17: Power-Up/Initialization Flow Chart

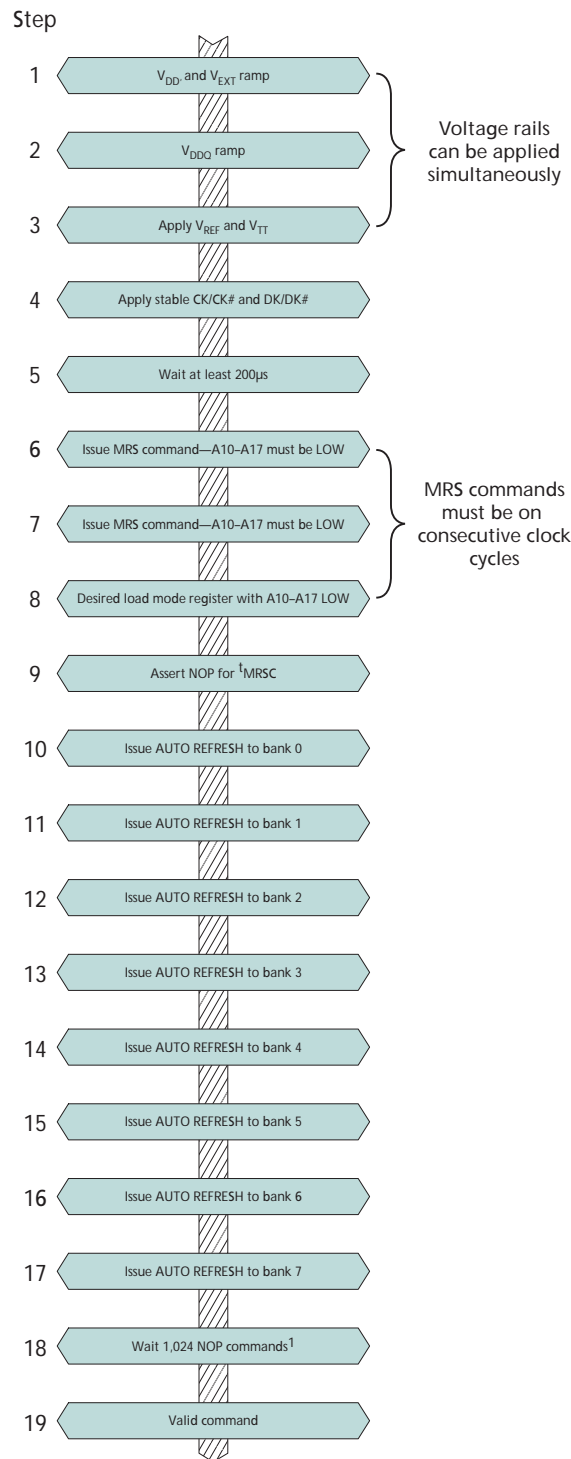

Notes: 1. The sequence of the eight AUTO REFRESH commands (with respect to the 1,024 NOP commands) does not matter. As is required for any operation, t_{RC} must be met between an AUTO REFRESH command and a subsequent VALID command to the same bank.

WRITE

Figure 18: WRITE Burst

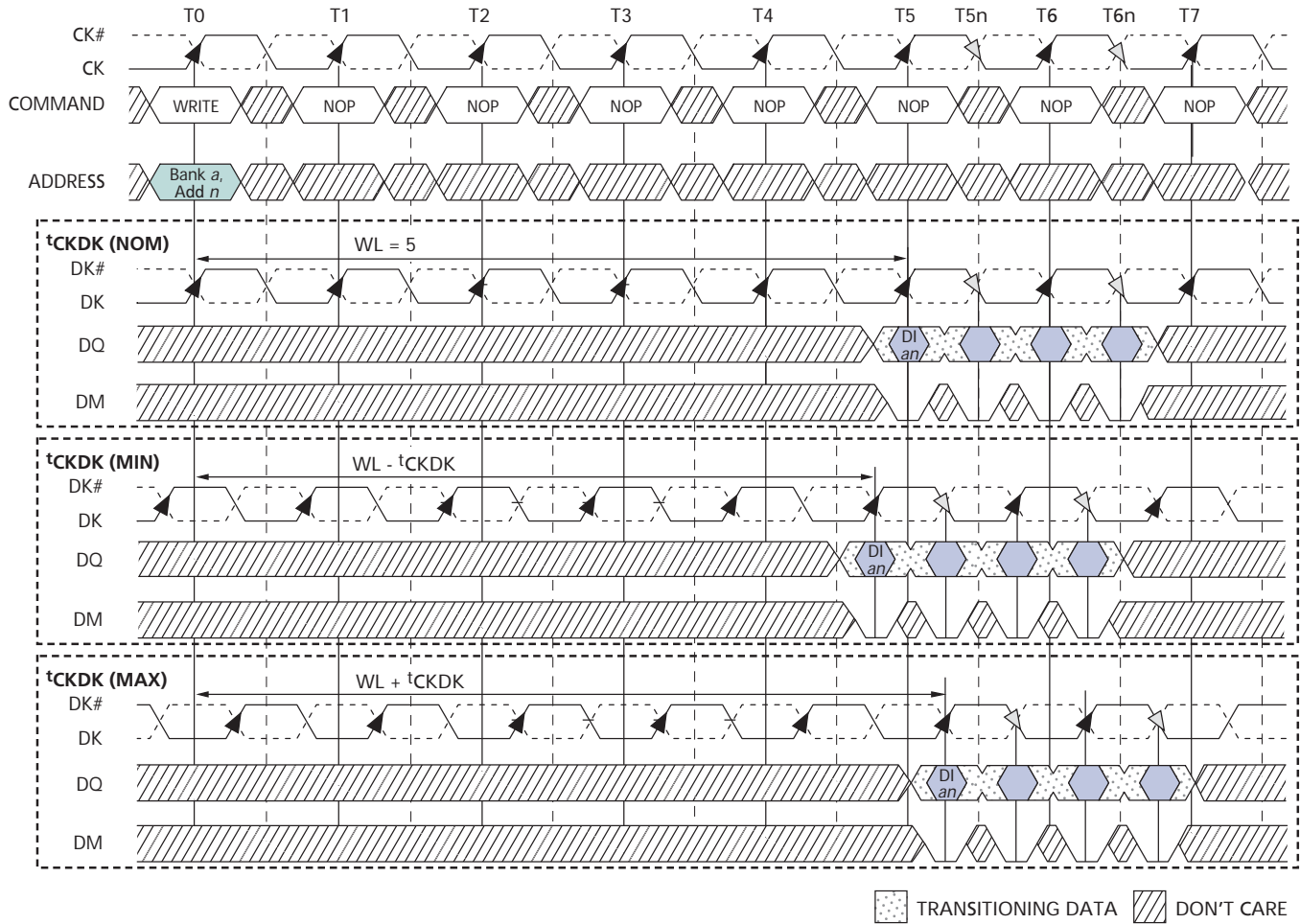

- Notes:
1. DI_{an} = data-in for bank a and address n ; subsequent elements of burst are applied following DI_{an} .
 2. $BL = 4$.

Figure 19: Consecutive WRITE-to-WRITE

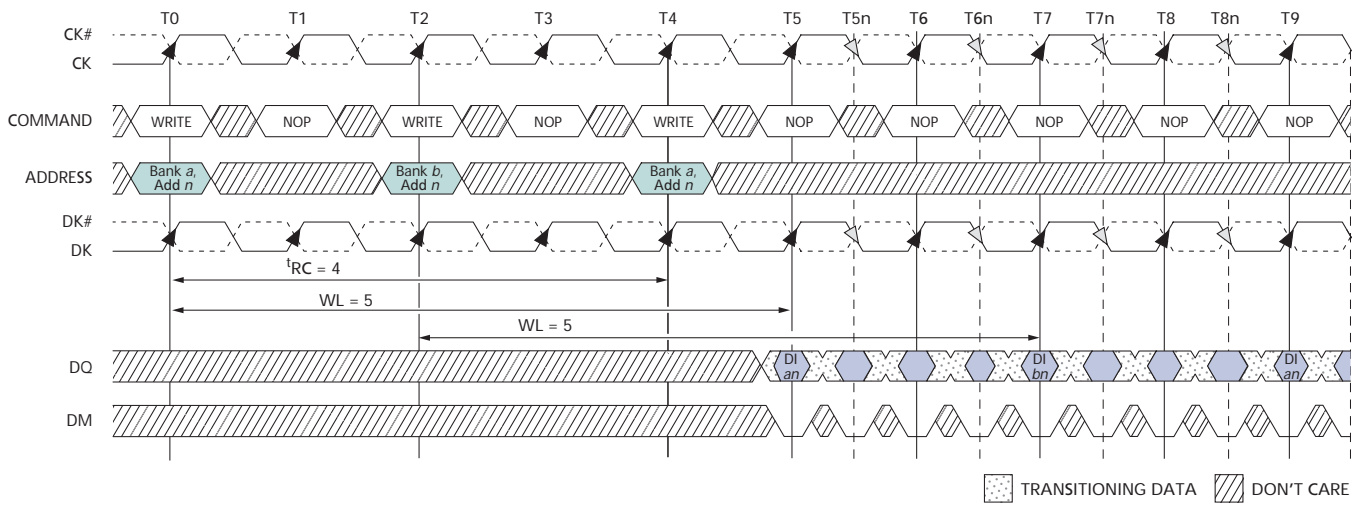

- Notes:
1. DI_{an} (or DI_{bn}) = data-in for bank a (or b) and address n .
 2. Three subsequent elements of the burst are applied following DI for each bank.
 3. $BL = 4$.
 4. Each WRITE command may be to any bank; if the second WRITE is to the same bank, t_{RC} must be met.
 5. Nominal conditions are assumed for specifications not defined.

Figure 20: WRITE-to-READ

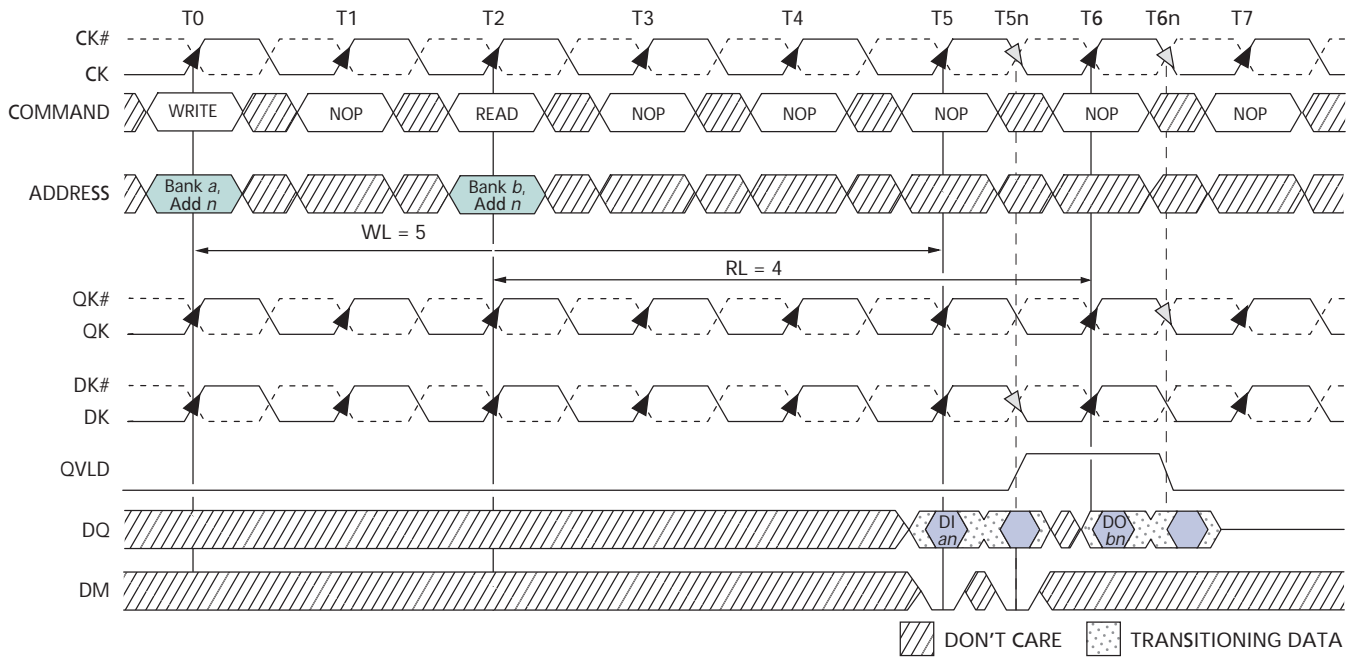

- Notes:
1. DI an = data-in for bank a and address n .
 2. DO bn = data-out from bank b and address n .
 3. Two subsequent elements of each burst follow DI an and DO bn .
 4. BL = 2.
 5. Nominal conditions are assumed for specifications not defined.

Figure 21: WRITE-to-READ (Separated by Two NOPs)

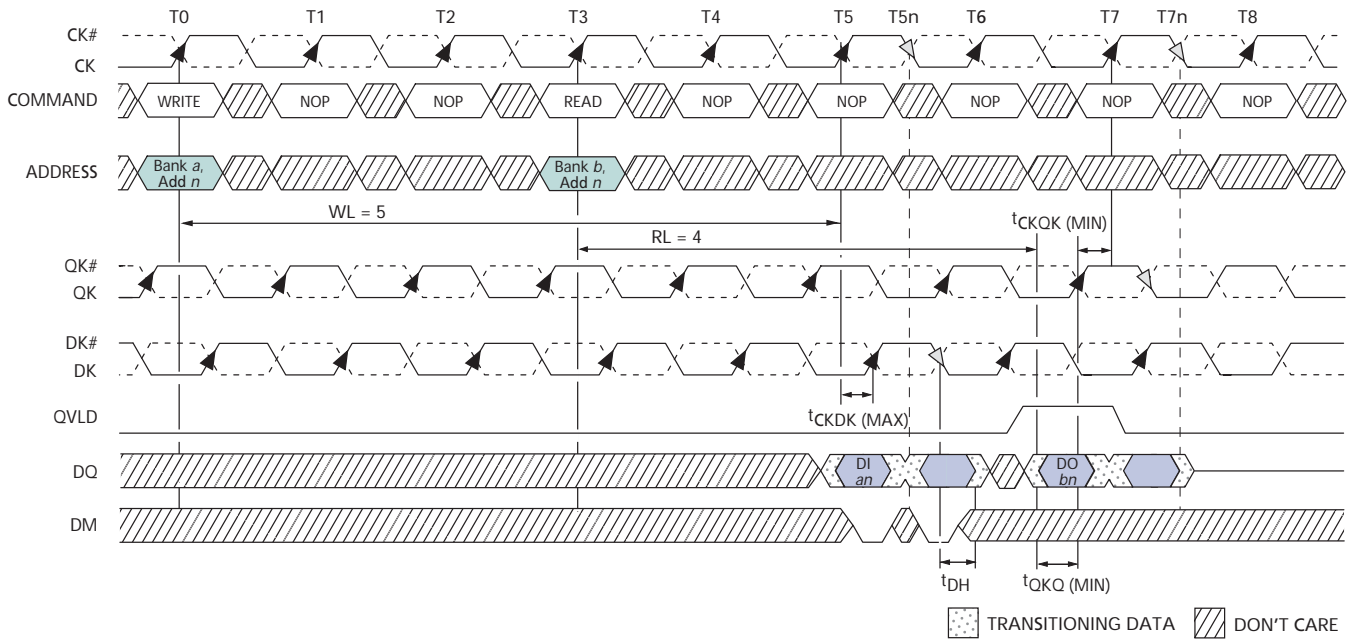

- Notes:
1. DI an = data-in for bank a and address n .
 2. DO bn = data-out from bank b and address n .
 3. One subsequent element of each burst follow both DI an and DO bn .
 4. BL = 2.
 5. Only one NOP separating the WRITE and READ would have led to contention on the data bus because of the input and output data timing conditions being used.
 6. Nominal conditions are assumed for specifications not defined.

Figure 22: WRITE - DM Operation

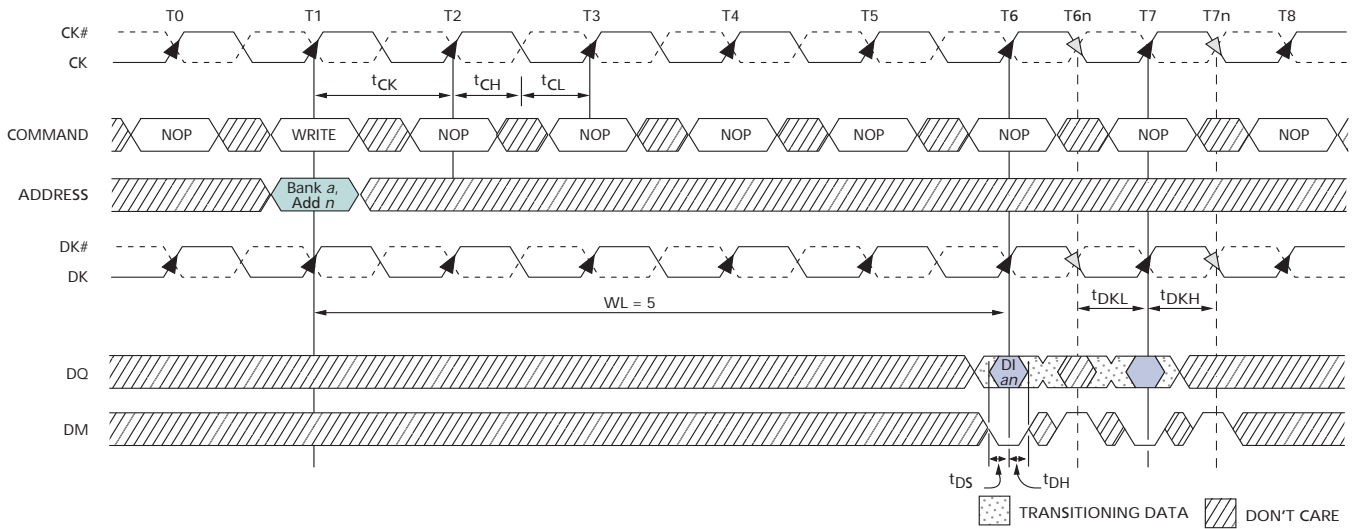

- Notes:
1. DI an = data-in for bank a and address n .
 2. Subsequent elements of burst are provided on following clock edges.
 3. BL = 4.
 4. Nominal conditions are assumed for specifications not defined.

READ

Figure 23: Basic READ Burst Timing

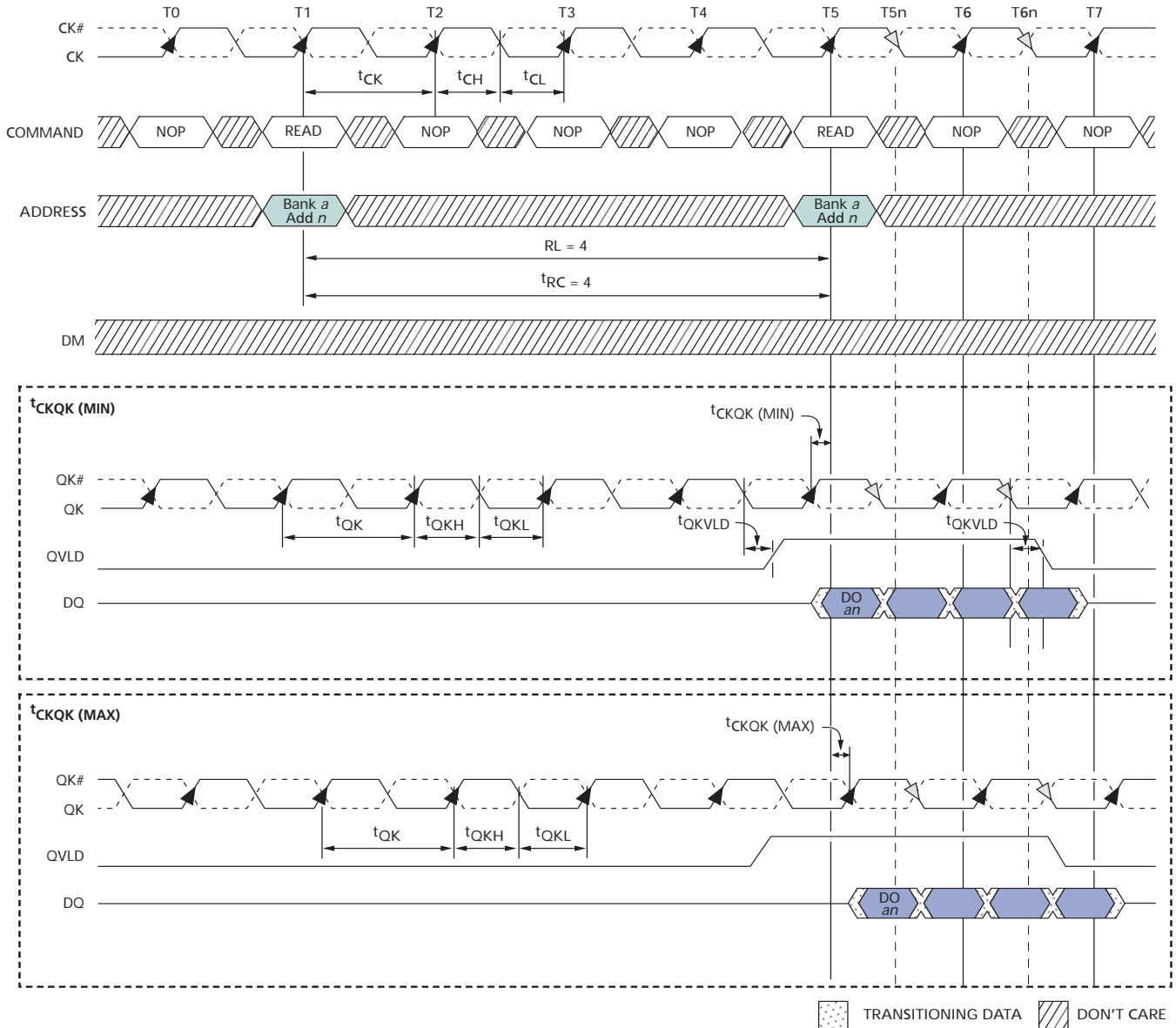

- Notes:
1. DO an = data-out from bank a and address an .
 2. Three subsequent elements of the burst are applied following DO an .
 3. BL = 4.
 4. Nominal conditions are assumed for specifications not defined.

Figure 24: Consecutive READ Bursts (BL = 2)

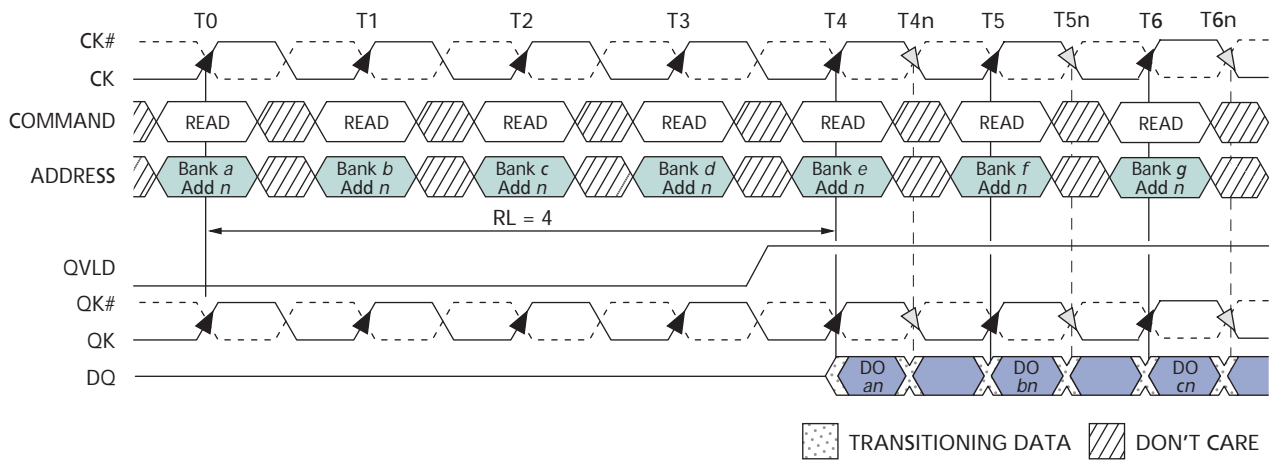

- Notes:
1. DO_{an} (or DO_{bn} or DO_{cn}) = data-out from bank a (or bank b or bank c) and address n .
 2. One subsequent element of the burst from each bank appears after each DO_x .
 3. Nominal conditions are assumed for specifications not defined.
 4. Example applies only when READ commands are issued to same device.
 5. Bank address can be to any bank, but the subsequent READ can only be to the same bank if t_{RC} has been met.
 6. Data from the READ commands to bank d through bank g will appear on subsequent clock cycles that are not shown.

Figure 25: Consecutive READ Bursts (BL = 4)

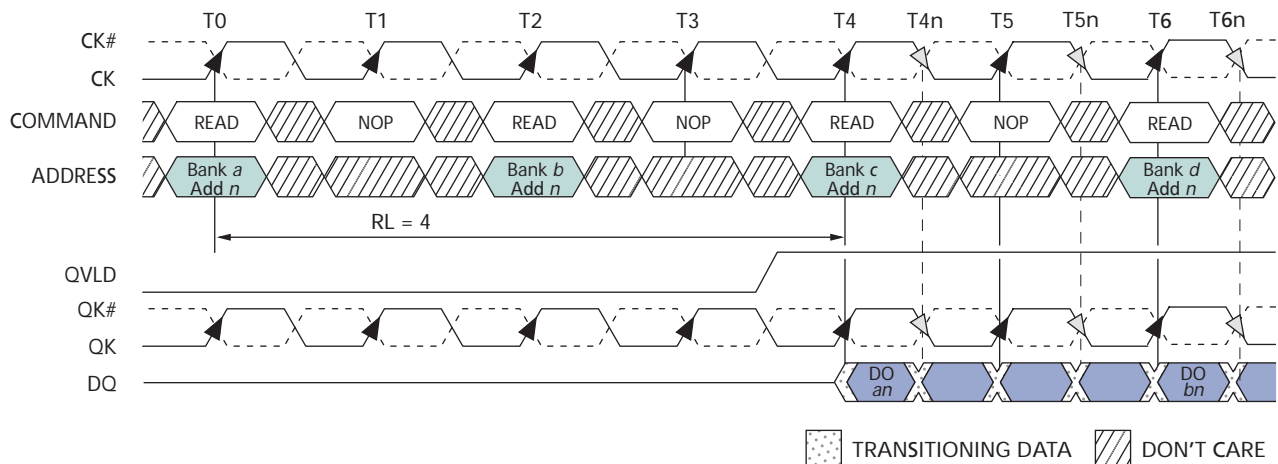

- Notes:
1. DO_{an} (or DO_{bn}) = data-out from bank a (or bank b) and address n .
 2. Three subsequent elements of the burst from each bank appears after each DO_x .
 3. Nominal conditions are assumed for specifications not defined.
 4. Example applies only when READ commands are issued to same device.
 5. Bank address can be to any bank, but the subsequent READ can only be to the same bank if t_{RC} has been met.
 6. Data from the READ commands to banks c and d will appear on subsequent clock cycles that are not shown.

Figure 26: READ-to-WRITE

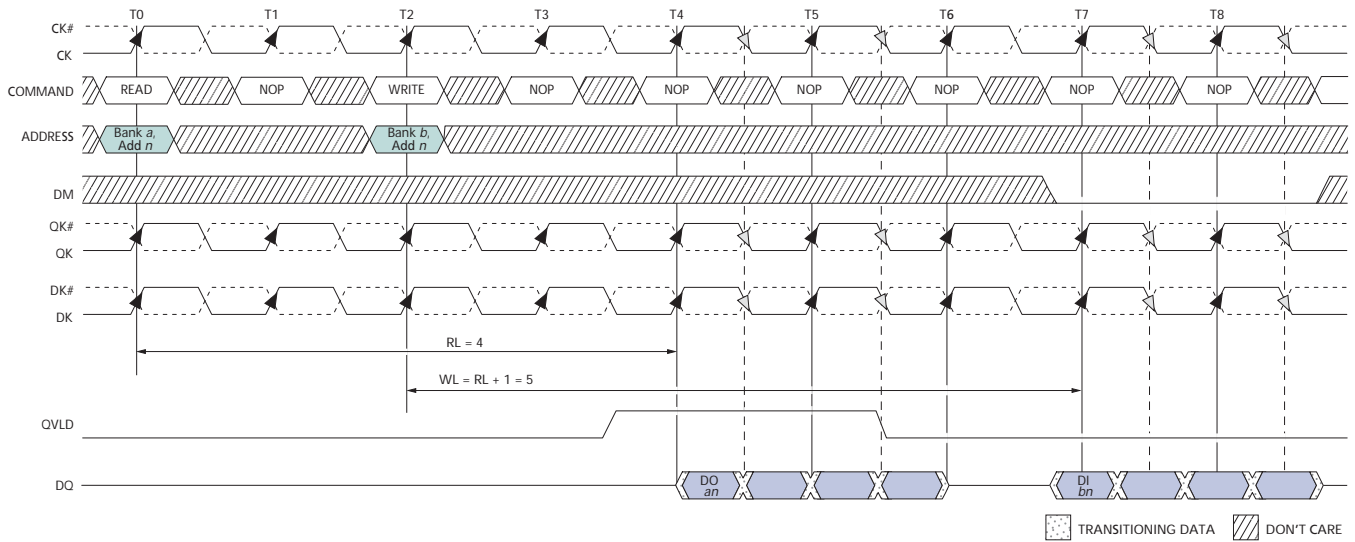

- Notes:
1. DO *an* = data-out from bank *a* and address *n*.
 2. DI *bn* = data-in for bank *b* and address *n*.
 3. Three subsequent elements of each burst follow DI *bn* and each DO *an*.
 4. BL = 4.
 5. Nominal conditions are assumed for specifications not defined.

Figure 27: Read Data Valid Window for x9 Device

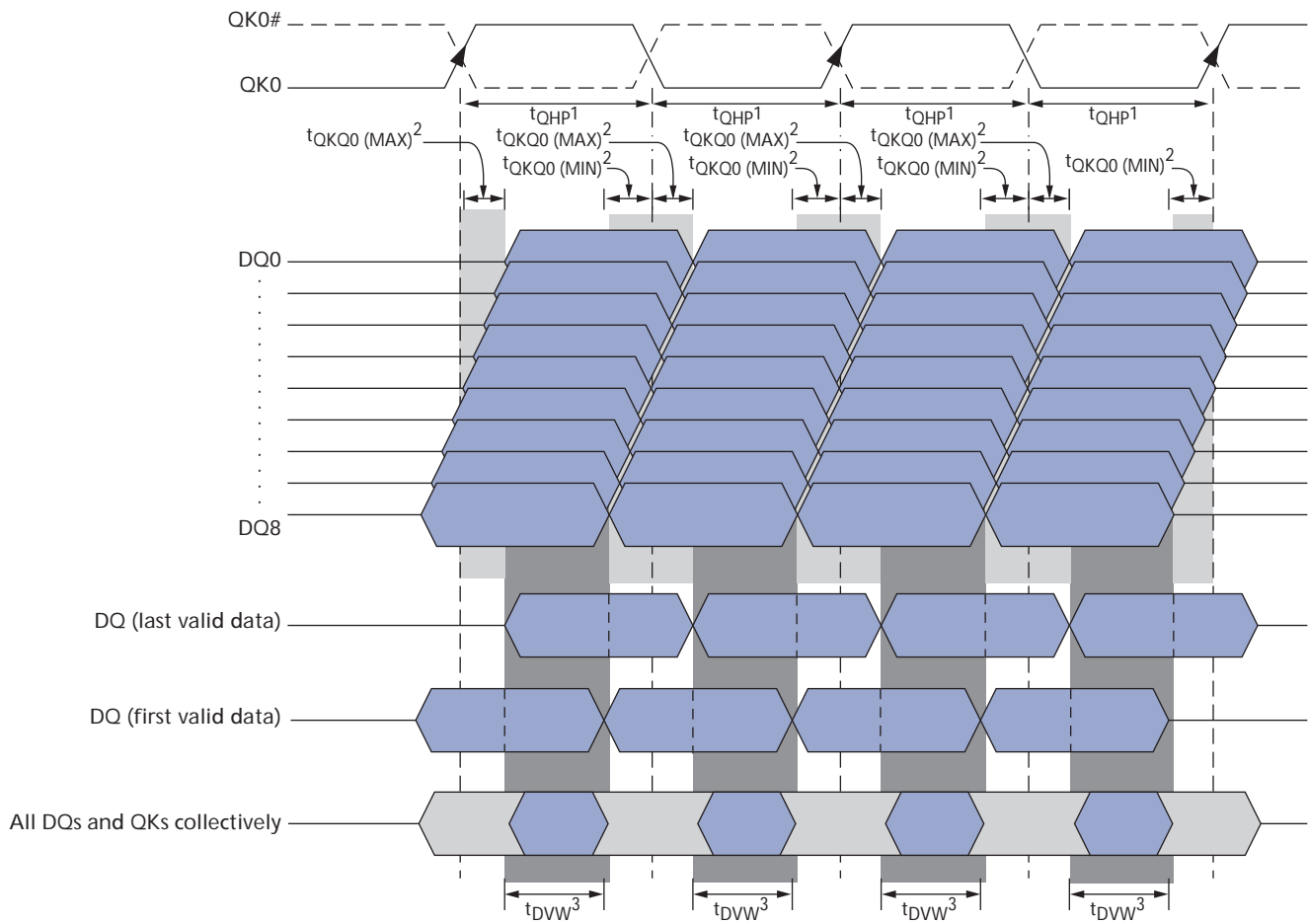

- Notes:
1. t_{QHP} is defined as the lesser of t_{QKH} or t_{QKL} .
 2. t_{QKQ0} is referenced to DQ0-DQ8.
 3. Minimum data valid window (t_{DVW}) can be expressed as $t_{QHP} - (t_{QKQx [MAX]} + |t_{QKQx [MIN]}|)$.

Figure 28: Read Data Valid Window for x18 Device

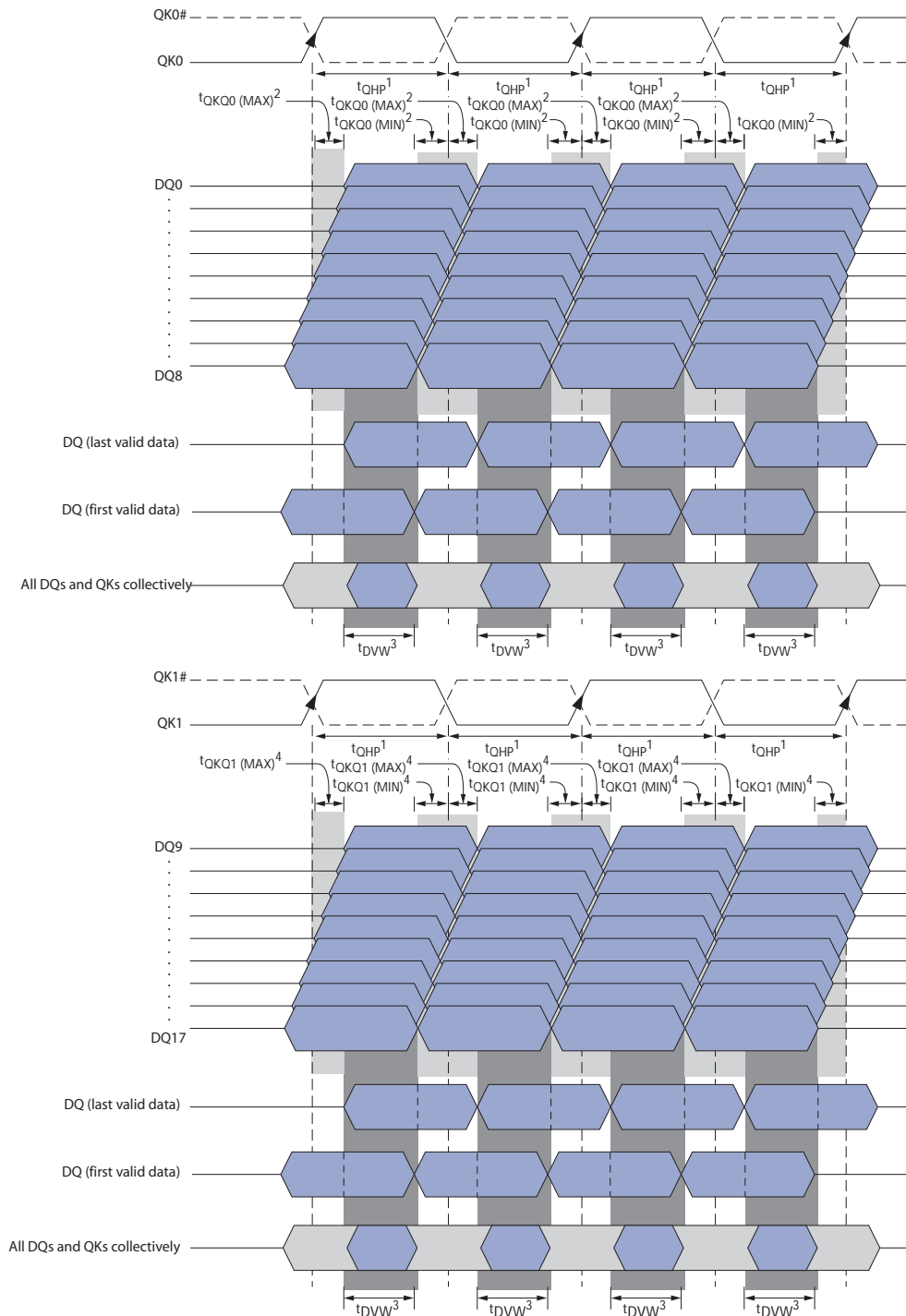

- Notes:
1. t_{QHP}^1 is defined as the lesser of t_{QKH} or t_{QKL} .
 2. t_{QKQ0}^2 is referenced to DQ0–DQ8.
 3. Minimum data valid window (t_{DVW}^3) can be expressed as $t_{QHP}^1 - (t_{QKQx}^2 [MAX] + |t_{QKQx}^2 [MIN]|)$.
 4. t_{QKQ1}^4 is referenced to DQ9–DQ17.
 5. t_{QKQ} takes into account the skew between any QKx and any DQ.

Figure 29: Read Data Valid Window for x36 Device

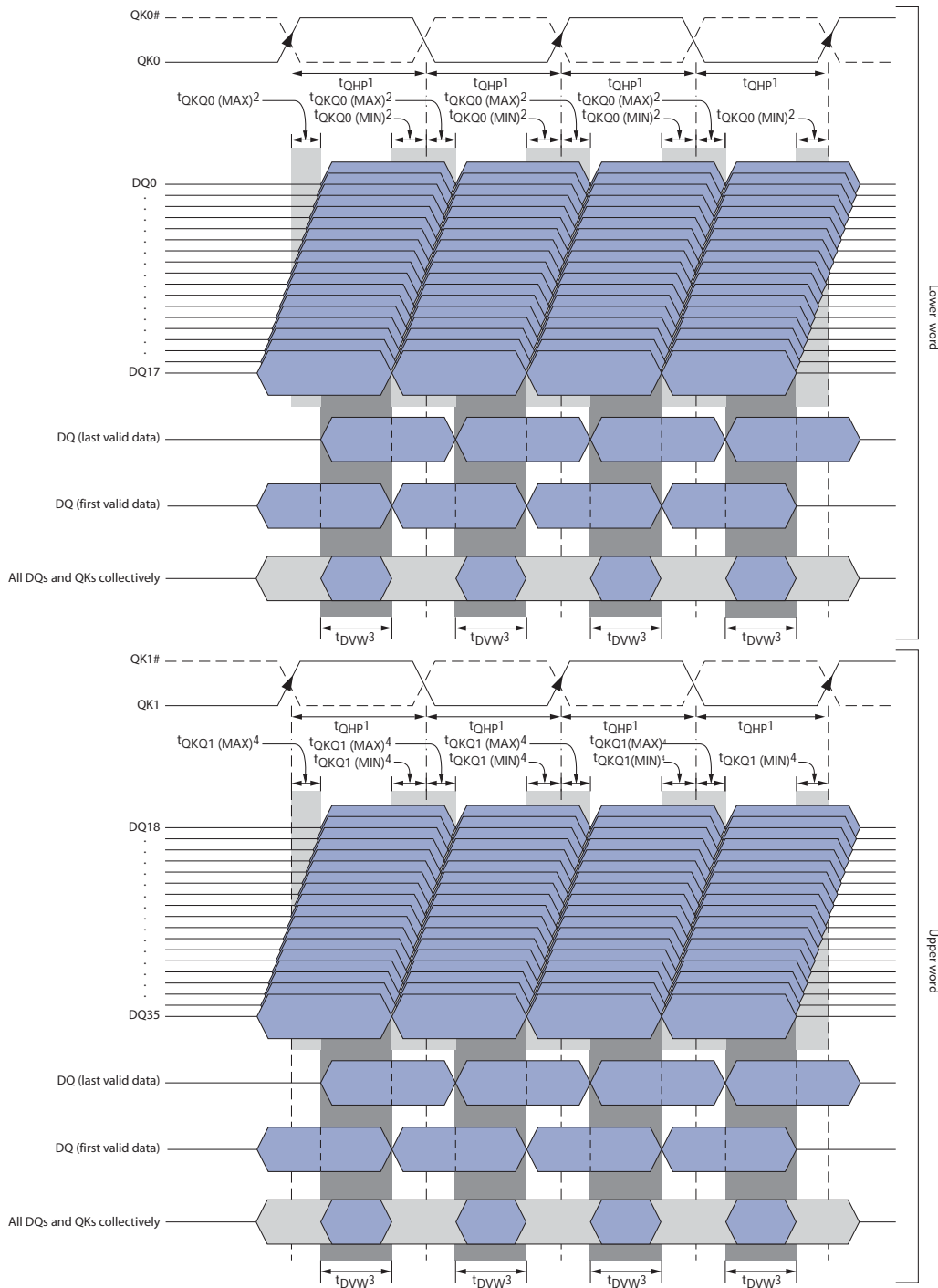

- Notes:
- t_{QHP} is defined as the lesser of t_{QKH} or t_{QKL} .
 - t_{QKQ0} is referenced to DQ0–DQ17.
 - Minimum data valid window, $t_{D VW}$, can be expressed as $t_{QHP} - (t_{QKQx} [MAX] + |t_{QKQx} [MIN]|)$.
 - t_{QKQ1} is referenced to DQ18–DQ35.
 - t_{QKQ} takes into account the skew between any QKx and any DQ.

AUTO REFRESH

Figure 30: AUTO REFRESH Cycle

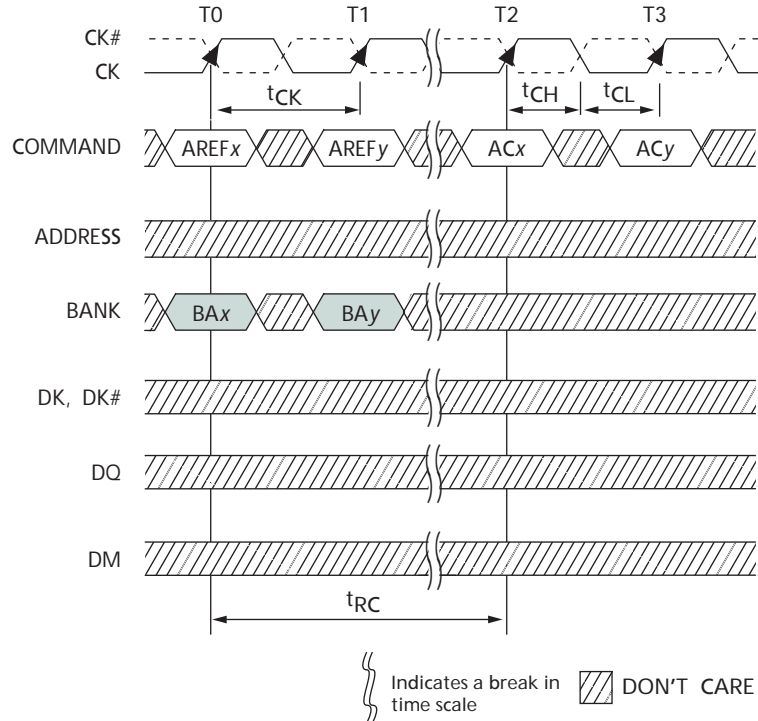

- Notes:
1. AREF x = AUTO REFRESH command to bank x .
 2. AC x = any command to bank x ; AC y = any command to bank y .
 3. BA x = bank address to bank x ; BA y = bank address to bank y .

On-Die Termination

Figure 31: READ Burst with ODT

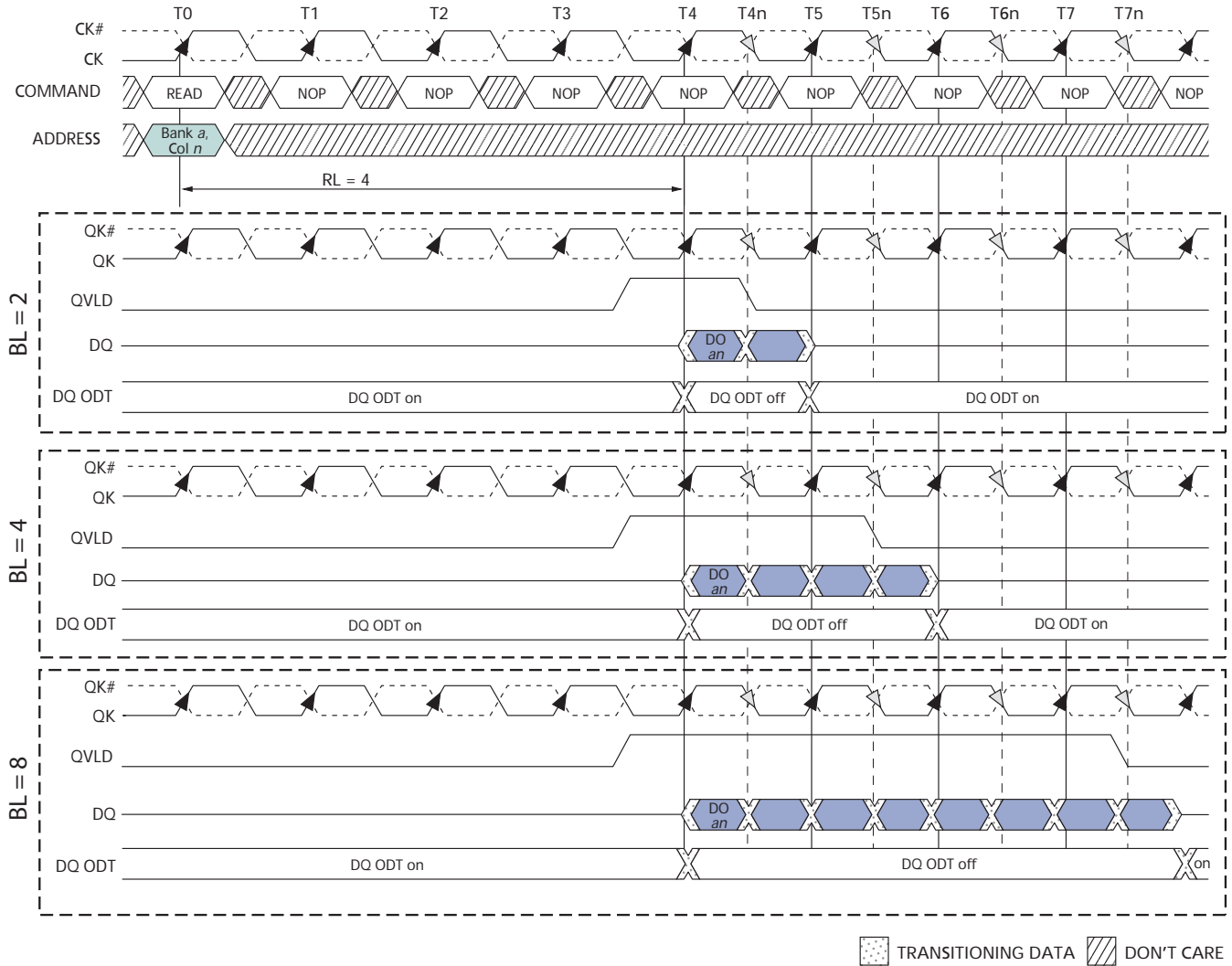

- Notes:
1. DO an = data out from bank a and address n .
 2. DO an is followed by the remaining bits of the burst.
 3. Nominal conditions are assumed for specifications not defined.

Figure 32: READ-NOP-READ with ODT

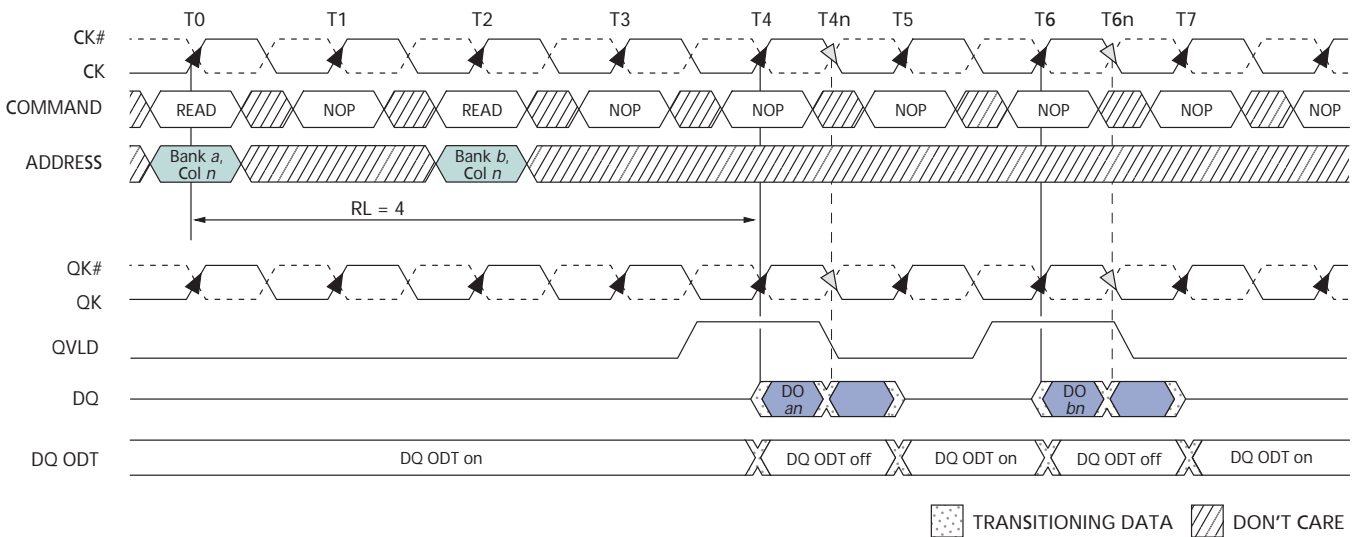

- Notes:
1. DO *an* (or *bn*) = data-out from bank *a* (or bank *b*) and address *n*.
 2. BL = 2.
 3. One subsequent element of the burst appear after DO *an* and DO *bn*.
 4. Nominal conditions are assumed for specifications not defined.

Figure 33: READ-to-WRITE with ODT

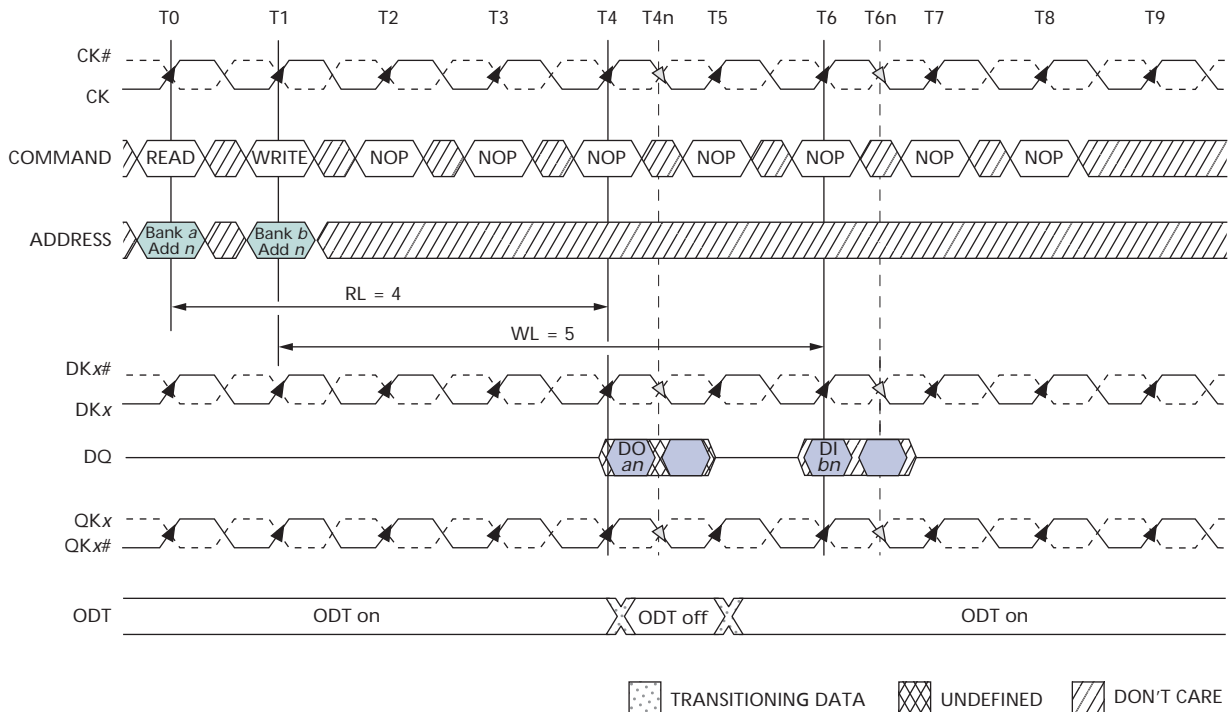

- Notes:
1. DO *an* = data-out from bank *a* and address *n*; DI *bn* = data-in for bank *b* and address *n*.
 2. BL = 2.
 3. One subsequent element of each burst appears after each DO *an* and DI *bn*.
 4. Nominal conditions are assumed for specifications not defined.

Multiplexed Address Mode

Figure 34: Command Description in Multiplexed Address Mode

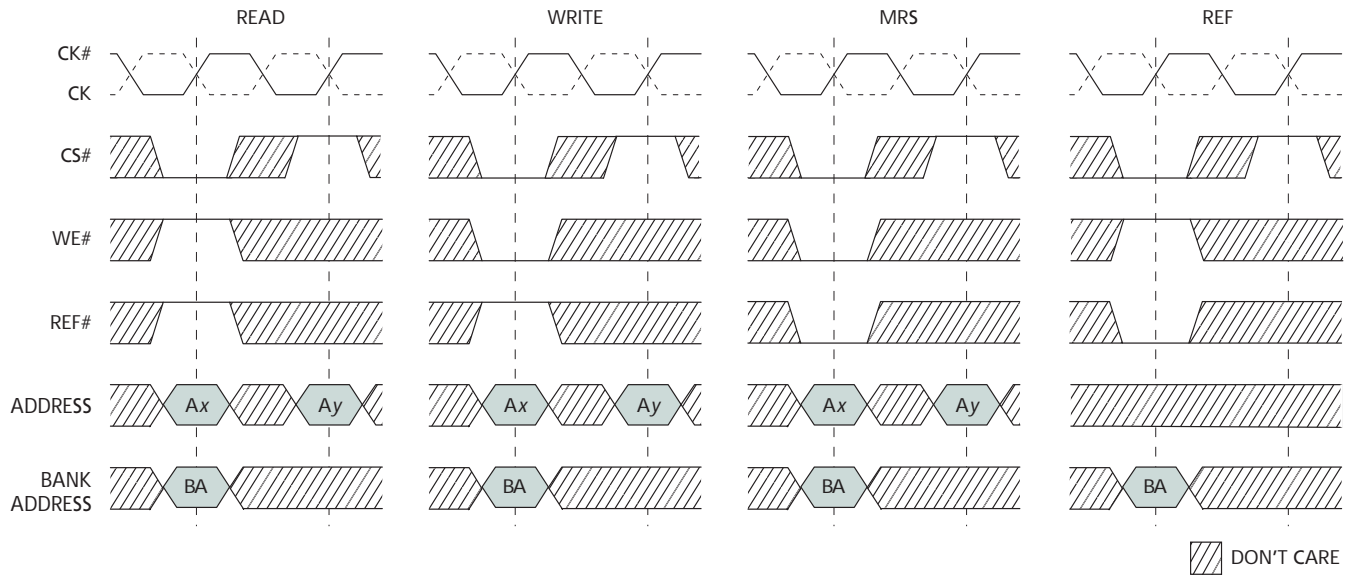

Notes: 1. The minimum setup and hold times of the two address parts are defined t_{AS} and t_{AH} .

Figure 35: Power-Up/Initialization Sequence in Multiplexed Address Mode

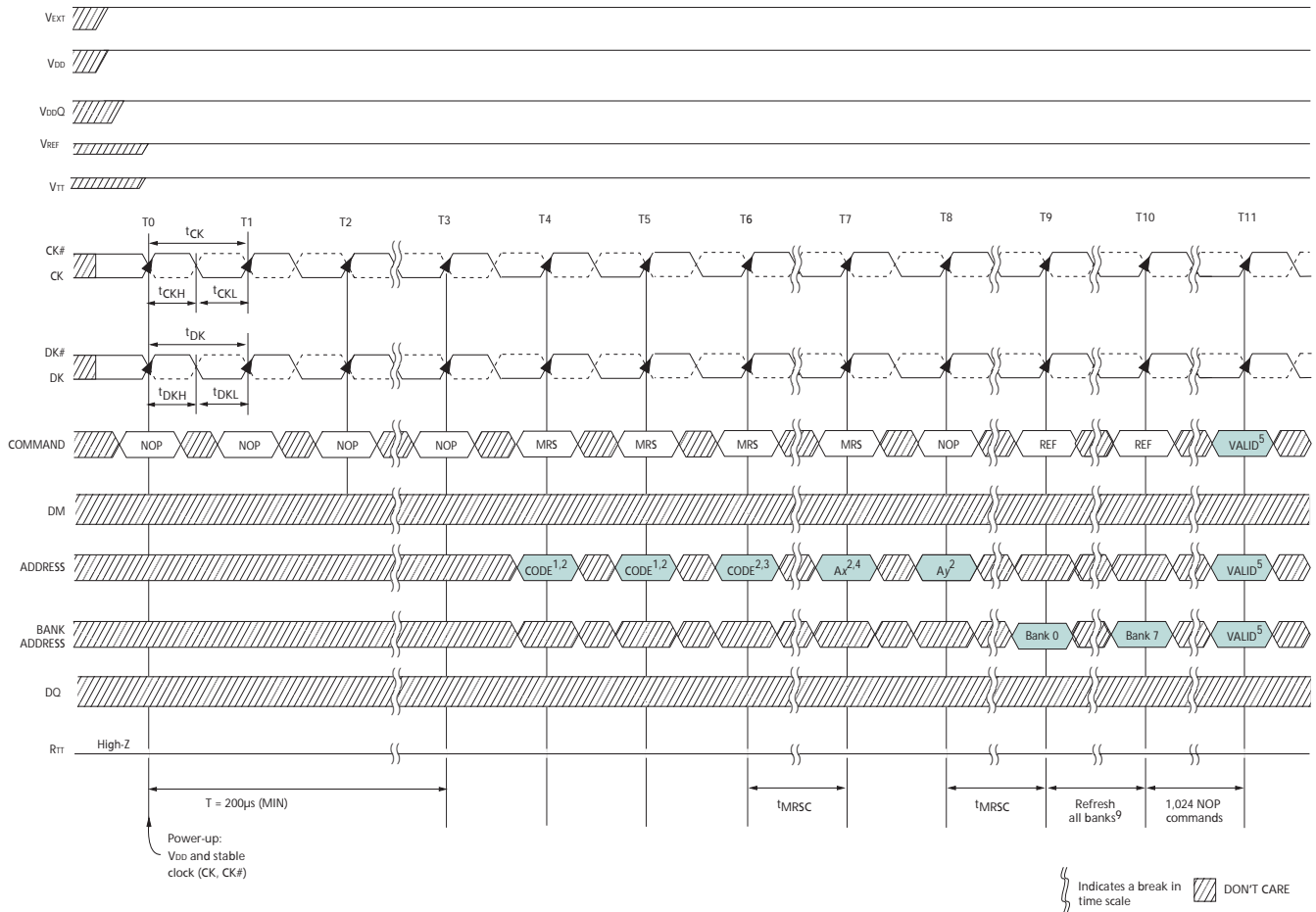

- Notes:
1. Recommended that all address pins held LOW during dummy MRS commands.
 2. A10–A18 must be LOW.
 3. Set address A5 HIGH. This enables the part to enter multiplexed address mode when in non-multiplexed mode operation. Multiplexed address mode can also be entered at some later time by issuing an MRS command with A5 HIGH. Once address bit A5 is set HIGH, t_{MRSC} must be satisfied before the two-cycle multiplexed mode MRS command is issued.
 4. Address A5 must be set HIGH. This and the following step set the desired mode register once the RLD RAM is in multiplexed address mode.
 5. Any command or address.
 6. The above sequence must be followed in order to power up the RLD RAM in the multiplexed address mode.
 7. DLL must be reset if t_{CK} or V_{DD} are changed.
 8. CK and $CK\#$ must separated at all times to prevent bogus commands from being issued.
 9. The sequence of the eight AUTO REFRESH commands (with respect to the 1,024 NOP commands) does not matter. As is required for any operation, t_{RC} must be met between an AUTO REFRESH command and a subsequent $VALID$ command to the same bank.

Figure 36: Mode Register Definition in Multiplexed Address Mode

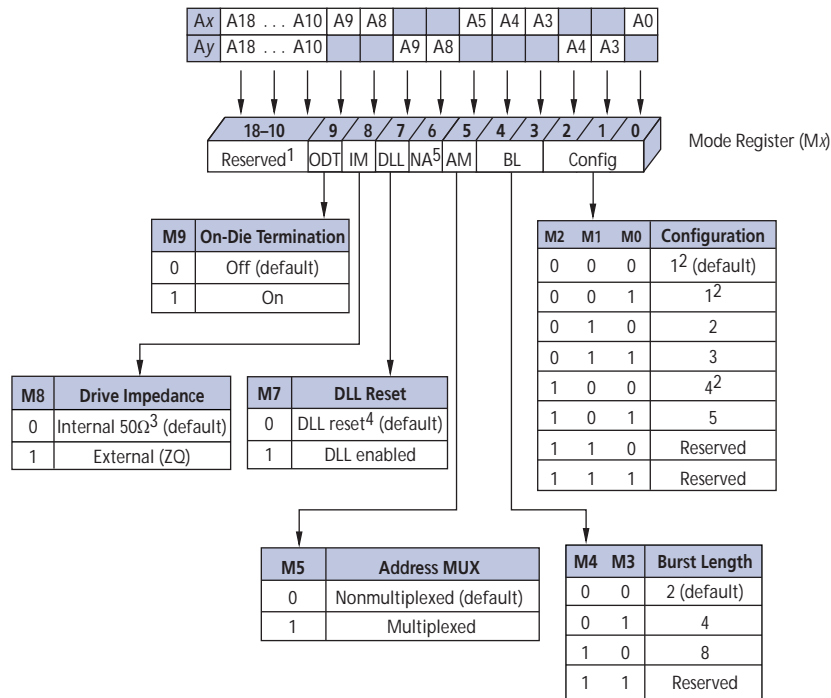

- Notes:
1. Bits A10–A18 must be set to zero.
 2. BL = 8 is not available.
 3. ±30% temperature variation.
 4. DLL RESET turns the DLL off.
 5. Ay8 not used in MRS.
 6. BA0–BA2 are “Don’t Care.”
 7. Addresses A0, A3, A4, A5, A8, and A9 must be set as shown in order to activate the mode register in the multiplexed address mode.



Address Mapping in Multiplexed Address Mode

Table 22: 288Mb Address Mapping in Multiplexed Address Mode

Data Width	Burst Length	Ball	Address										
			A0	A3	A4	A5	A8	A9	A10	A13	A14	A17	A18
x36	2	Ax	A0	A3	A4	A5	A8	A9	A10	A13	A14	A17	A18
		Ay	X	A1	A2	X	A6	A7	X	A11	A12	A16	A15
	4	Ax	A0	A3	A4	A5	A8	A9	A10	A13	A14	A17	X
		Ay	X	A1	A2	X	A6	A7	X	A11	A12	A16	A15
	8	Ax	A0	A3	A4	A5	A8	A9	A10	A13	A14	X	X
		Ay	X	A1	A2	X	A6	A7	X	A11	A12	A16	A15
x18	2	Ax	A0	A3	A4	A5	A8	A9	A10	A13	A14	A17	A18
		Ay	X	A1	A2	X	A6	A7	A19	A11	A12	A16	A15
	4	Ax	A0	A3	A4	A5	A8	A9	A10	A13	A14	A17	A18
		Ay	X	A1	A2	X	A6	A7	X	A11	A12	A16	A15
	8	Ax	A0	A3	A4	A5	A8	A9	A10	A13	A14	A17	X
		Ay	X	A1	A2	X	A6	A7	X	A11	A12	A16	A15
x9	2	Ax	A0	A3	A4	A5	A8	A9	A10	A13	A14	A17	A18
		Ay	A20	A1	A2	X	A6	A7	A19	A11	A12	A16	A15
	4	Ax	A0	A3	A4	A5	A8	A9	A10	A13	A14	A17	A18
		Ay	X	A1	A2	X	A6	A7	A19	A11	A12	A16	A15
	8	Ax	A0	A3	A4	A5	A8	A9	A10	A13	A14	A17	A18
		Ay	X	A1	A2	X	A6	A7	X	A11	A12	A16	A15

Notes: 1. X = "Don't Care."

Configuration Tables in Multiplexed Address Mode

In multiplexed address mode, the read and write latencies are increased by one clock cycle. However, the RLD RAM cycle time remains the same as when in non-multiplexed address mode.

Table 23: Cycle Time and READ/WRITE Latency Configuration Table in Multiplexed Mode

Notes 1 apply to the entire table

Parameter	Configuration					Units
	1 ²	2	3	4 ^{2, 3}	5	
t _{RC}	4	6	8	3	5	t _{CK}
t _{RL}	5	7	9	4	6	t _{CK}
t _{WL}	6	8	10	5	7	t _{CK}
Valid frequency range	266–175	400–175	533–175	200–175	333–175	MHz

- Notes:
- t_{RC} < 20ns in any configuration is only available with -25E and -18 speed grades.
 - BL = 8 is not available.
 - The minimum t_{RC} is typically 3 cycles, except in the case of a WRITE followed by a READ to the same bank. In this instance the minimum t_{RC} is 4 cycles.

REFRESH Command in Multiplexed Address Mode

Similar to other commands when in multiplexed address mode, AREF is executed on the rising clock edge following the one on which the command is issued. However, since only the bank address is required for AREF, the next command can be applied on the following clock. The operation of the AREF command and any other command is represented in Figure 37 on page 63.

Figure 37: BURST REFRESH Operation with Multiplexed Addressing

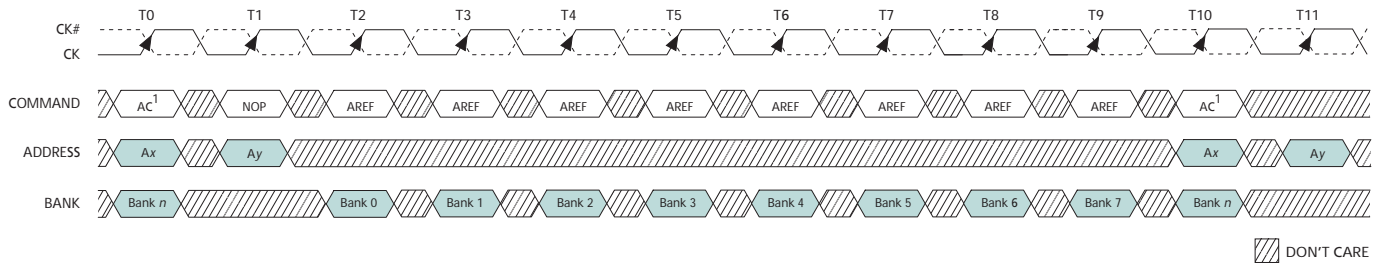

- Notes:
- Any command.
 - Bank *n* is chosen so that t_{RC} is met.

Figure 39: WRITE-to-READ with Multiplexed Addressing

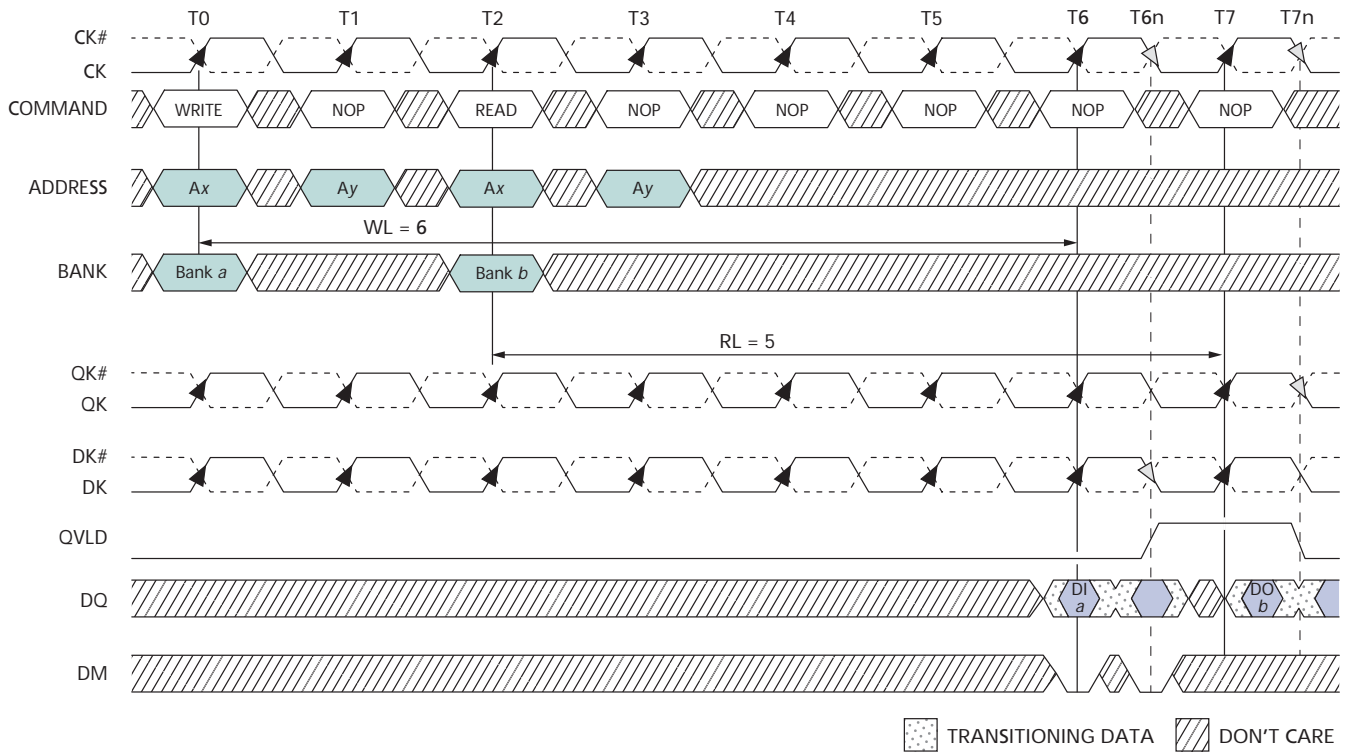

- Notes:
1. DI *a* = data-in for bank *a*.
 2. DO *b* = data-out from bank *b*.
 3. One subsequent element of each burst follows DI *a* and DO *b*.
 4. BL = 2.
 5. Nominal conditions are assumed for specifications not defined.
 6. Bank address can be to any bank, but the subsequent READ can only be to the same bank if t_{RC} has been met.

Figure 40: Consecutive READ Bursts with Multiplexed Addressing

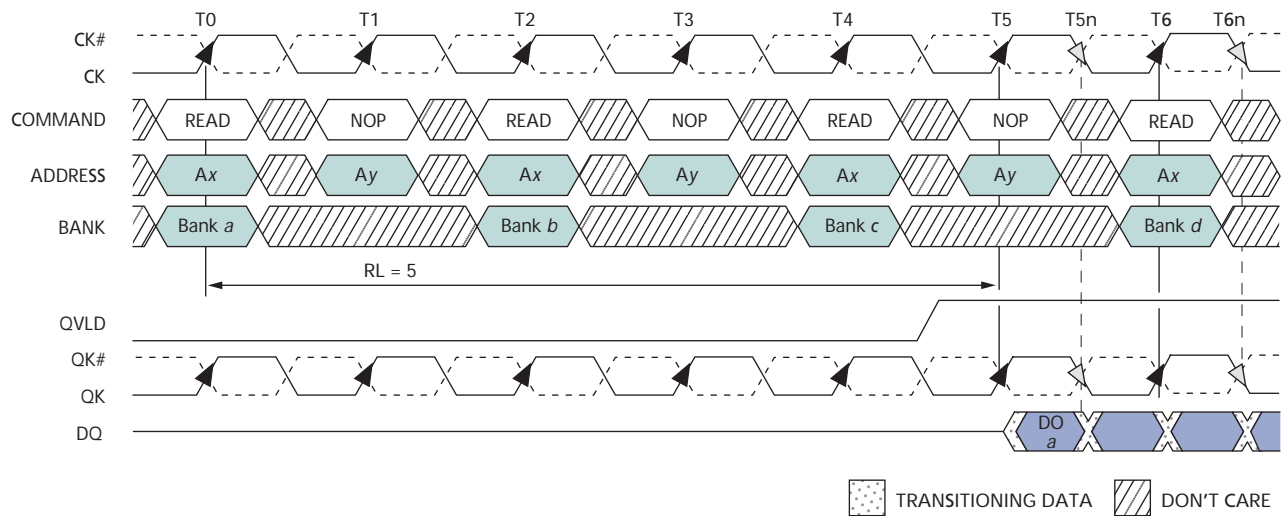

- Notes:
1. DO *a* = data-out from bank *a*.
 2. Nominal conditions are assumed for specifications not defined.
 3. BL = 4.
 4. Three subsequent elements of the burst appear following DO *a*.
 5. Example applies only when READ commands are issued to same device.
 6. Bank address can be to any bank, but the subsequent READ can only be to the same bank if t_{RC} has been met.
 7. Data from the READ commands to banks *b* through bank *d* will appear on subsequent clock cycles that are not shown.

Figure 41: READ-to-WRITE with Multiplexed Addressing

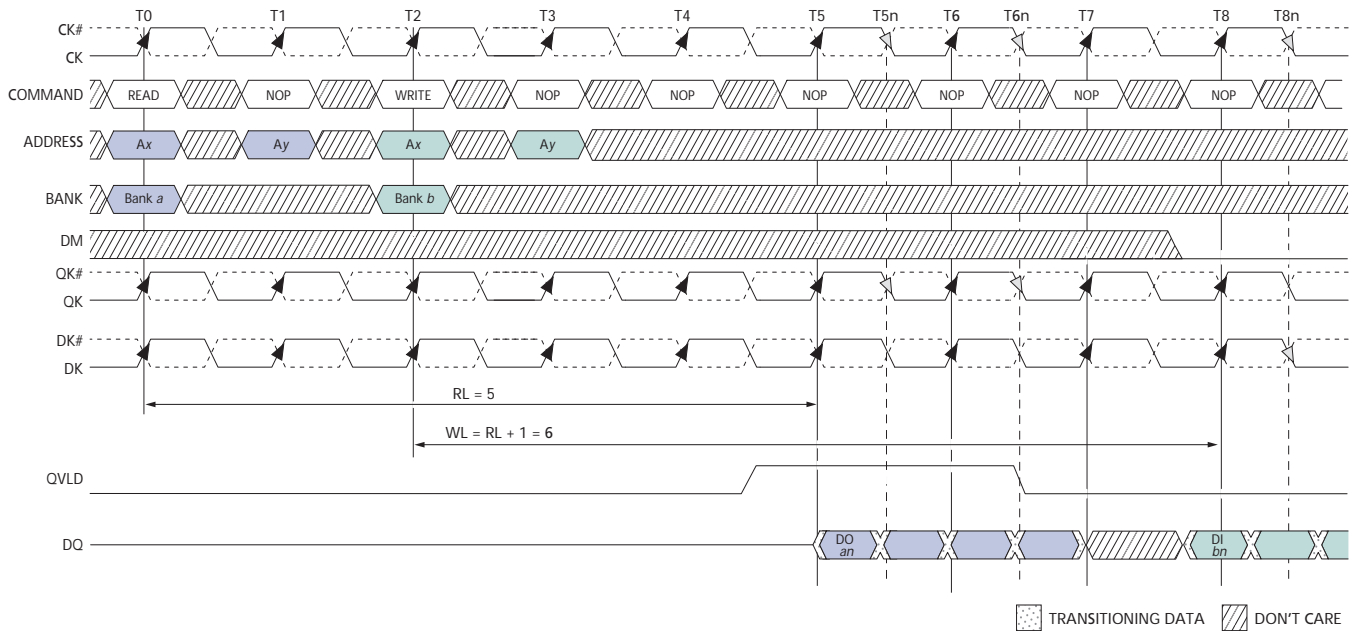

- Notes:
1. DO *an* = data-out from bank *a*.
 2. DI *bn* = data-in for bank *b*.
 3. Nominal conditions are assumed for specifications not defined.
 4. BL = 4.
 5. Three subsequent elements of the burst are applied following DO *an*.
 6. Three subsequent elements of the burst which appear following DI *bn* are not all shown.
 7. Bank address can be to any bank, but the WRITE command can only be to the same bank if t_{RC} has been met.

IEEE 1149.1 Serial Boundary Scan (JTAG)

RLDRAM incorporates a serial boundary-scan test access port (TAP) for the purpose of testing the connectivity of the device once it has been mounted on a printed circuit board (PCB). As the complexity of PCB high-density surface mounting techniques increases, the boundary-scan architecture is a valuable resource for interconnectivity debug. This port operates in accordance with IEEE Standard 1149.1-2001 (JTAG) with the exception of the ZQ pin. To ensure proper boundary-scan testing of the ZQ pin, MRS bit M8 needs to be set to 0 until the JTAG testing of the pin is complete. Note that upon power up, the default state of MRS bit M8 is low.

If the RLD RAM boundary scan register is to be used upon power up and prior to the initialization of the RLD RAM device, it is imperative that the CK and CK# pins meet $V_{ID(DC)}$ or CS# be held HIGH from power up until testing. Not doing so could result in inadvertent MRS commands to be loaded, and subsequently cause unexpected results from address pins that are dependent upon the state of the mode register. If these measures cannot be taken, the part must be initialized prior to boundary scan testing. If a full initialization is not practical or feasible prior to boundary scan testing, a single MRS command with desired settings may be issued instead. After the single MRS command is issued, the tMRSC parameter must be satisfied prior to boundary scan testing.

The input signals of the test access port (TDI, TMS, and TCK) use V_{DD} as a supply, while the output signal of the TAP (TDO) uses V_{DDQ} .

The JTAG test access port utilizes the TAP controller on the RLD RAM, from which the instruction register, boundary scan register, bypass register, and ID register can be selected. Each of these functions of the TAP controller is described in detail below.

Disabling the JTAG Feature

It is possible to operate RLD RAM without using the JTAG feature. To disable the TAP controller, TCK must be tied LOW (V_{SS}) to prevent clocking of the device. TDI and TMS are internally pulled up and may be unconnected. They may alternately be connected to V_{DD} through a pull-up resistor. TDO should be left unconnected. Upon power-up, the device will come up in a reset state, which will not interfere with the operation of the device.

Test Access Port (TAP)

Test Clock (TCK)

The test clock is used only with the TAP controller. All inputs are captured on the rising edge of TCK. All outputs are driven from the falling edge of TCK.

Test Mode Select (TMS)

The TMS input is used to give commands to the TAP controller and is sampled on the rising edge of TCK.

All of the states in Figure 42: "TAP Controller State Diagram," on page 70 are entered through the serial input of the TMS pin. A "0" in the diagram represents a LOW on the TMS pin during the rising edge of TCK while a "1" represents a HIGH on TMS.

Test Data-In (TDI)

The TDI ball is used to serially input test instructions and data into the registers and can be connected to the input of any of the registers. The register between TDI and TDO is chosen by the instruction that is loaded into the TAP instruction register. For information on loading the instruction register, see Figure 42 on page 70. TDI is connected to the most significant bit (MSB) of any register (see Figure 43 on page 70).

Test Data-Out (TDO)

The TDO output ball is used to serially clock test instructions and data out from the registers. The TDO output driver is only active during the Shift-IR and Shift-DR TAP controller states. In all other states, the TDO pin is in a High-Z state. The output changes on the falling edge of TCK. TDO is connected to the least significant bit (LSB) of any register (see Figure 43 on page 70).

TAP Controller

The TAP controller is a finite state machine that uses the state of the TMS pin at the rising edge of TCK to navigate through its various modes of operation. The TAP controller state diagram can be seen in Figure 42 on page 70. Each state is described in detail below.

Test-Logic-Reset

The test-logic-reset controller state is entered when TMS is held HIGH for at least five consecutive rising edges of TCK. As long as TMS remains HIGH, the TAP controller will remain in the test-logic-reset state. The test logic is inactive during this state.

Run-Test/Idle

The run-test/idle is a controller state in between scan operations. This state can be maintained by holding TMS LOW. From here either the data register scan, or subsequently, the instruction register scan can be selected.

Select-DR-Scan

Select-DR-scan is a temporary controller state. All test data registers retain their previous state while here.

Capture-DR

The capture-DR state is where the data is parallel-loaded into the test data registers. If the boundary scan register is the currently selected register, then the data currently on the pins is latched into the test data registers.

Shift-DR

Data is shifted serially through the data register while in this state. As new data is input through the TDI pin, data is shifted out of the TDO pin.

Exit1-DR, Pause-DR, and Exit2-DR

The purpose of exit1-DR is used to provide a path to return back to the run-test/idle state (through the update-DR state). The pause-DR state is entered when the shifting of data through the test registers needs to be suspended. When shifting is to reconvene, the controller enters the exit2-DR state and then can re-enter the shift-DR state.

Update-DR

When the EXTEST instruction is selected, there are latched parallel outputs of the boundary-scan shift register that only change state during the update-DR controller state.

Instruction Register States

The instruction register states of the TAP controller are similar to the data register states. The desired instruction is serially shifted into the instruction register during the shift-IR state and is loaded during the update-IR state.

Figure 42: TAP Controller State Diagram

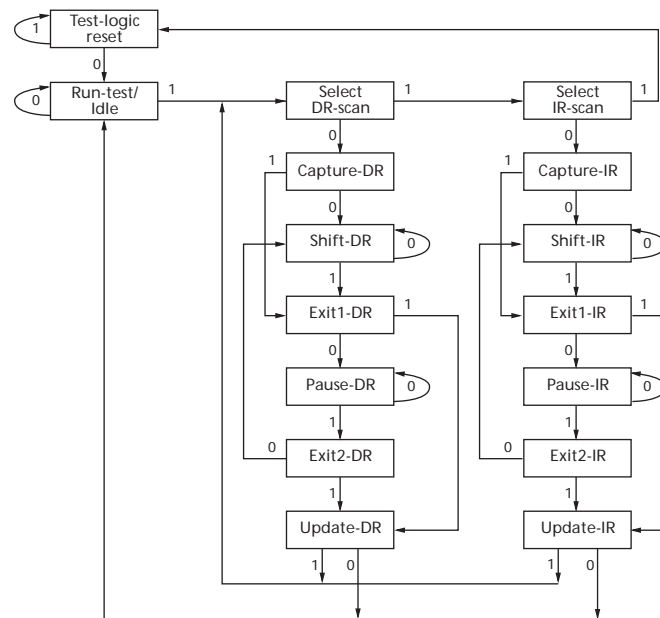
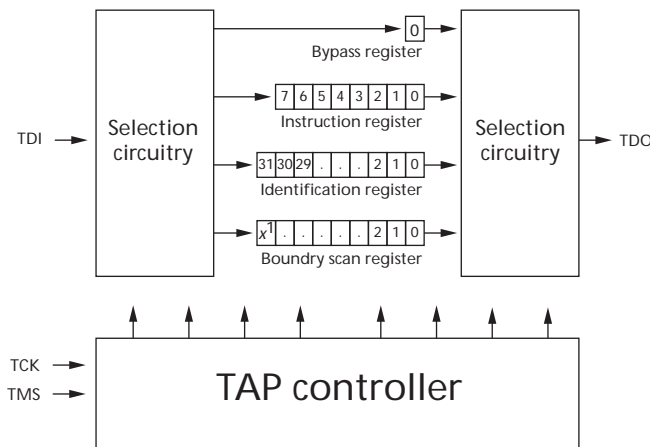

Figure 43: TAP Controller Block Diagram



Notes: 1. $x = 112$ for all configurations.

Performing a TAP RESET

A reset is performed by forcing TMS HIGH (V_{DDQ}) for five rising edges of TCK. This RESET does not affect the operation of the RLD RAM and may be performed while the RLD RAM is operating.

At power-up, the TAP is reset internally to ensure that TDO comes up in a High-Z state.

TAP Registers

Registers are connected between the TDI and TDO balls and allow data to be scanned into and out of the RLD RAM test circuitry. Only one register can be selected at a time through the instruction register. Data is serially loaded into the TDI ball on the rising edge of TCK. Data is output on the TDO ball on the falling edge of TCK.

Instruction Register

Eight-bit instructions can be serially loaded into the instruction register. This register is loaded during the update-IR state of the TAP controller. Upon power-up, the instruction register is loaded with the IDCODE instruction. It is also loaded with the IDCODE instruction if the controller is placed in a reset state as described in the previous section.

When the TAP controller is in the capture-IR state, the two LSBs are loaded with a binary "01" pattern to allow for fault isolation of the board-level serial test data path.

Bypass Register

To save time when serially shifting data through registers, it is sometimes advantageous to skip certain chips. The bypass register is a single-bit register that can be placed between the TDI and TDO balls. This allows data to be shifted through the RLD RAM with minimal delay. The bypass register is set LOW (V_{SS}) when the BYPASS instruction is executed.

Boundary Scan Register

The boundary scan register is connected to all the input and bidirectional balls on the RLD RAM. Several balls are also included in the scan register to reserved balls. The RLD RAM has a 113-bit register.

The boundary scan register is loaded with the contents of the RAM I/O ring when the TAP controller is in the capture-DR state and is then placed between the TDI and TDO balls when the controller is moved to the shift-DR state.

Table 30 on page 76 shows the order in which the bits are connected. Each bit corresponds to one of the balls on the RLD RAM package. The MSB of the register is connected to TDI, and the LSB is connected to TDO.

Identification (ID) Register

The ID register is loaded with a vendor-specific, 32-bit code during the capture-DR state when the IDCODE command is loaded in the instruction register. The IDCODE is hard-wired into the RLD RAM and can be shifted out when the TAP controller is in the shift-DR state. The ID register has a vendor code and other information described in Table 27 on page 75.

TAP Instruction Set

Overview

Many different instructions (2^8) are possible with the 8-bit instruction register. All combinations used are listed in Table 29 on page 76. These six instructions are described in detail below. The remaining instructions are reserved and should not be used.

The TAP controller used in this RLD RAM is fully compliant to the 1149.1 convention.

Instructions are loaded into the TAP controller during the shift-IR state when the instruction register is placed between TDI and TDO. During this state, instructions are shifted through the instruction register through the TDI and TDO balls. To execute the instruction once it is shifted in, the TAP controller needs to be moved into the update-IR state.

EXTEST

The EXTEST instruction allows circuitry external to the component package to be tested. Boundary-scan register cells at output balls are used to apply a test vector, while those at input balls capture test results. Typically, the first test vector to be applied using the EXTEST instruction will be shifted into the boundary scan register using the PRELOAD instruction. Thus, during the update-IR state of EXTEST, the output driver is turned on, and the PRELOAD data is driven onto the output balls.

IDCODE

The IDCODE instruction causes a vendor-specific, 32-bit code to be loaded into the instruction register. It also places the instruction register between the TDI and TDO balls and allows the IDCODE to be shifted out of the device when the TAP controller enters the shift-DR state. The IDCODE instruction is loaded into the instruction register upon power-up or whenever the TAP controller is given a test logic reset state.

High-Z

The High-Z instruction causes the boundary scan register to be connected between the TDI and TDO. This places all RLD RAM outputs into a High-Z state.

CLAMP

When the CLAMP instruction is loaded into the instruction register, the data driven by the output balls are determined from the values held in the boundary scan register.

SAMPLE/PRELOAD

When the SAMP LE/PRELOAD instruction is loaded into the instruction register and the TAP controller is in the capture-DR state, a snapshot of data on the inputs and bidirectional balls is captured in the boundary scan register.

The user must be aware that the TAP controller clock can only operate at a frequency up to 50 MHz, while the RLD RAM clock operates significantly faster. Because there is a large difference between the clock frequencies, it is possible that during the capture-DR state, an input or output will undergo a transition. The TAP may then try to capture a signal while in transition (metastable state). This will not harm the device, but there is no guarantee as to the value that will be captured. Repeatable results may not be possible.

To ensure that the boundary scan register will capture the correct value of a signal, the RLD RAM signal must be stabilized long enough to meet the TAP controller's capture setup plus hold time (t_{CS} plus t_{CH}). The RLD RAM clock input might not be captured

correctly if there is no way in a design to stop (or slow) the clock during a SAMPLE/PRELOAD instruction. If this is an issue, it is still possible to capture all other signals and simply ignore the value of the CK and CK# captured in the boundary scan register.

Once the data is captured, it is possible to shift out the data by putting the TAP into the shift-DR state. This places the boundary scan register between the TDI and TDO balls.

BYPASS

When the BYPASS instruction is loaded in the instruction register and the TAP is placed in a shift-DR state, the bypass register is placed between TDI and TDO. The advantage of the BYPASS instruction is that it shortens the boundary scan path when multiple devices are connected together on a board.

Reserved for Future Use

The remaining instructions are not implemented but are reserved for future use. Do not use these instructions.

Figure 44: JTAG Operation – Loading Instruction Code and Shifting Out Data

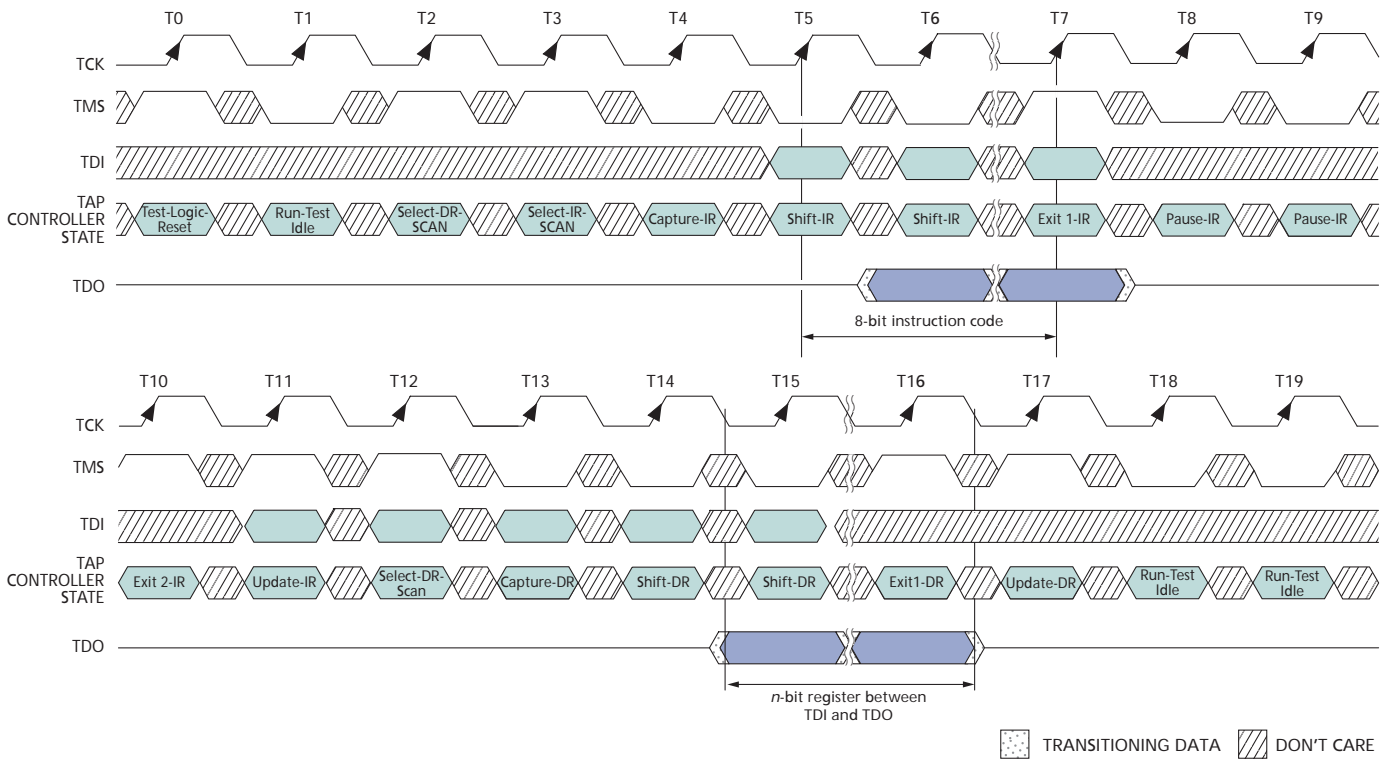

Figure 45: TAP Timing

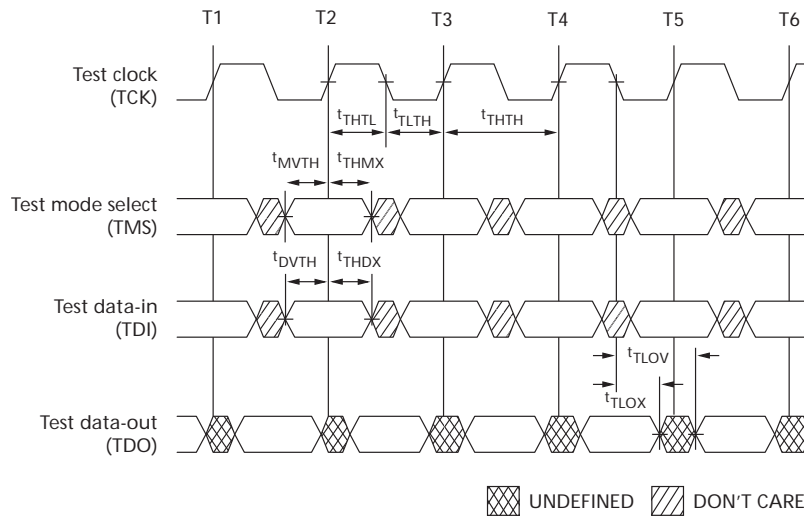

Table 24: TAP Input AC Logic Levels

+0°C ≤ T_C ≤ +95°C; +1.7V ≤ V_{DD} ≤ +1.9V, unless otherwise noted

Description	Symbol	Min	Max	Units
Input high (logic 1) voltage	V _{IH}	V _{REF} + 0.3	-	V
Input low (logic 0) voltage	V _{IL}	-	V _{REF} - 0.3	V

Notes: 1. All voltages referenced to V_{SS} (GND).

Table 25: TAP AC Electrical Characteristics

+0°C ≤ T_C ≤ +95°C; +1.7V ≤ V_{DD} ≤ +1.9V

Description	Symbol	Min	Max	Units
Clock				
Clock cycle time	t _{THTH}	20		ns
Clock frequency	f _{TF}		50	MHz
Clock HIGH time	t _{THTL}	10		ns
Clock LOW time	t _{TLTH}	10		ns
TDI/TDO times				
TCK LOW to TDO unknown	t _{TLOX}	0		ns
TCK LOW to TDO valid	t _{TLOV}		10	ns
TDI valid to TCK HIGH	t _{DVTH}	5		ns
TCK HIGH to TDI invalid	t _{THDX}	5		ns
Setup times				
TMS setup	t _{MVTH}	5		ns
Capture setup	t _{CS}	5		ns
Hold times				
TMS hold	t _{THMX}	5		ns
Capture hold	t _{CH}	5		ns

Notes: 1. t_{CS} and t_{CH} refer to the setup and hold time requirements of latching data from the boundary scan register.



Table 26: TAP DC Electrical Characteristics and Operating Conditions

+0°C ≤ T_C ≤ +95°C; +1.7V ≤ V_{DD} ≤ +1.9V, unless otherwise noted

Description	Condition	Symbol	Min	Max	Units	Notes
Input high (logic 1) voltage		V _{IH}	V _{REF} + 0.15	V _{DD} + 0.3	V	1, 2
Input low (logic 0) voltage		V _{IL}	V _{SSQ} - 0.3	V _{REF} - 0.15	V	1, 2
Input leakage current	0V ≤ V _{IN} ≤ V _{DD}	I _{LI}	-5.0	5.0	μA	
Output leakage current	Output disabled, 0V ≤ V _{IN} ≤ V _{DDQ}	I _{LO}	-5.0	5.0	μA	
Output low voltage	I _{OLc} = 100μA	V _{OL1}		0.2	V	1
Output low voltage	I _{OLt} = 2mA	V _{OL2}		0.4	V	1
Output high voltage	I _{OHc} = 100μA	V _{OH1}	V _{DDQ} - 0.2		V	1
Output high voltage	I _{OHt} = 2mA	V _{OH2}	V _{DDQ} - 0.4		V	1

- Notes: 1. All voltages referenced to V_{SS} (GND).
 2. Overshoot = V_{IH(AC)} ≤ V_{DD} + 0.7V for t ≤ t^{CK}/2; undershoot = V_{IL(AC)} ≥ -0.5V for t ≤ t^{CK}/2; during normal operation, V_{DDQ} must not exceed V_{DD}.

Table 27: Identification Register Definitions

Instruction Field	All Devices	Description
Revision number (31:28)	abcd	ab = 00 for Die Rev. A, 01 for Die Rev. B cd = 00 for x9, 01 for x18, 10 for x36
Device ID (27:12)	00jkidef10100111	def = 000 for 288Mb, 001 for 576Mb i = 0 for common I/O, 1 for separate I/O jk = 01 for RLD RAM 2, 00 for RLD RAM
Micron JEDEC ID code (11:1)	00000101100	Allows unique identification of RLD RAM vendor
ID register presence indicator (0)	1	Indicates the presence of an ID register

Table 28: Scan Register Sizes

Register Name	Bit Size
Instruction	8
Bypass	1
ID	32
Boundary scan	113



Table 29: Instruction Codes

Instruction	Code	Description
Extest	0000 0000	Captures I/O ring contents; Places the boundary scan register between TDI and TDO; This operation does not affect RLD RAM operations
ID code	0010 0001	Loads the ID register with the vendor ID code and places the register between TDI and TDO; This operation does not affect RLD RAM operations
Sample/preload	0000 0101	Captures I/O ring contents; Places the boundary scan register between TDI and TDO
Clamp	0000 0111	Selects the bypass register to be connected between TDI and TDO; Data driven by output balls are determined from values held in the boundary scan register
High-Z	0000 0011	Selects the bypass register to be connected between TDI and TDO; All outputs are forced into High-Z
Bypass	1111 1111	Places the bypass register between TDI and TDO; This operation does not affect RLD RAM operations

Table 30: Boundary Scan (Exit) Order

Bit#	Ball	Bit#	Ball	Bit#	Ball
1	K1	39	R11	77	C11
2	K2	40	R11	78	C11
3	L2	41	P11	79	C10
4	L1	42	P11	80	C10
5	M1	43	P10	81	B11
6	M3	44	P10	82	B11
7	M2	45	N11	83	B10
8	N1	46	N11	84	B10
9	P1	47	N10	85	B3
10	N3	48	N10	86	B3
11	N3	49	P12	87	B2
12	N2	50	N12	88	B2
13	N2	51	M11	89	C3
14	P3	52	M10	90	C3
15	P3	53	M12	91	C2
16	P2	54	L12	92	C2
17	P2	55	L11	93	D3
18	R2	56	K11	94	D3
19	R3	57	K12	95	D2
20	T2	58	J12	96	D2
21	T2	59	J11	97	E2
22	T3	60	H11	98	E2
23	T3	61	H12	99	E3
24	U2	62	G12	100	E3
25	U2	63	G10	101	F2
26	U3	64	G11	102	F2
27	U3	65	E12	103	F3
28	V2	66	F12	104	F3
29	U10	67	F10	105	E1
30	U10	68	F10	106	F1
31	U11	69	F11	107	G2
32	U11	70	F11	108	G3



Table 30: Boundary Scan (Exit) Order (continued)

Bit#	Ball	Bit#	Ball	Bit#	Ball
33	T10	71	E10	109	G1
34	T10	72	E10	110	H1
35	T11	73	E11	111	H2
36	T11	74	E11	112	J2
37	R10	75	D11	113	J1
38	R10	76	D10	-	-

Notes: 1. Any unused balls in the order will read as a logic "0."

8000 S. Federal Way, P.O. Box 6, Boise, ID 83707-0006, Tel: 208-368-3900
www.micron.com/productsupport Customer Comment Line: 800-932-4992

Micron and the Micron logo are trademarks of Micron Technology, Inc. RLDRAM is a registered trademark of Qimonda AG in various countries, and is used by Micron Technology, Inc. under license from Qimonda. All other trademarks are the property of their respective owners. This data sheet contains minimum and maximum limits specified over the power supply and temperature range set forth herein. Although considered final, these specifications are subject to change, as further product development and data characterization sometimes occur.

Looking for pricing, stock, or lifecycle information?

Click below to explore more details on WIN SOURCE:

- ⊖ [View MT49H8M36BM-25E:B on WIN SOURCE](#)
- ⊖ [Micron Technology Inc. Information](#)

Optimize Your Supply Chain with WIN SOURCE Solutions

- ✓ Global Sourcing Solution
- ✓ Obsolete Management
- ✓ Cost Control Management
- ✓ Shortage Management
- ✓ Alternative Solution
- ✓ Excess Inventory Management