

Audio Interface ICs for Digital Cameras and Camcorders

# 1.1W to 1.5W Monaural Speaker Amplifiers



**BH7824FVM, BH7826FVM**

No.15090EBT01

●Description

The BH7824FVM and BH7826FVM are speaker amplifier ICs for low-voltage drives and low power consumption audio, specialized for mobile telephones and other mobile audio devices.

●Features

- 1) BTL monaural speaker amplifier
- 2) Capable of high power 500mW/8Ω/BTL output
- 3) Wide power supply voltage range
- 4) Supports active/shutdown modes
- 5) Built-in anti-pop circuit
- 6) Built-in thermal shutdown circuit

●Applications

Mobile telephones, PDAs, notebook computers, DSC, DVC, and other mobile audio devices.

●Product lineup

Part No.	BH7824FVM	BH7826FVM
Input type	Unbalanced input	Balanced input
Supply voltage(V)	2.4 ~ 5.5	2.6 ~ 5.5

●Absolute maximum ratings(Ta=25°C)

Parameter	Symbol	Limits	Unit
Supply voltage	V <sub>CCmax.</sub>	6.0	V
Power dissipation	P <sub>d</sub>	470(*1)	mW
Operating temperature	T <sub>opr</sub>	-30 ~ +85(*2)	°C
Storage temperature	T <sub>stg</sub>	-55 ~ +125	°C

\*1 Reduced by 4.7 mW/°C at 25°C or higher, when mounted on a 70mm×70mm×1.6mm PCB board.

\*2 T<sub>opr</sub>=70°C ~ 85°C is the range for performing basic operations and does not guarantee characteristics or rated output. Moreover, TSD (Thermal Shutdown) may become operable if input signals occurring in this range are excessive.

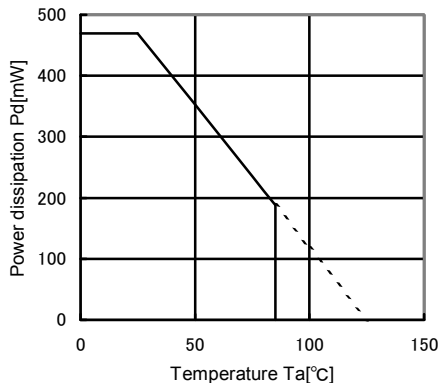

Fig.1 Ta-Pd (when mounted on a PCB board)

## ● Operating conditions (Ta=25°C)

Parameter	Ratings	
	BH7824FVM	BH7826FVM
Supply voltage	2.4V ~ 5.5V	2.6 ~ 5.5

\* Note: This IC is not designed to be radiation-resistant.

## ● Electrical characteristics (Unless otherwise noted Ta=25°C, Vcc=3.6V, f=1kHz, RL=8Ω)

Parameter	Symbol	Limits(Typ.)		Unit	Conditions
		BA7824FVM	BA7826FVM		
Circuit current 1	I <sub>CC1</sub>	3.5	3.5	mA	No signal , Active mode
Circuit current 2	I <sub>CC2</sub>	0	0	μA	No signal, Suspend mode
Voltage gain 1	G <sub>V1</sub>	+11.5	+11.5	dB	V <sub>IN</sub> =-20dBV, 1st Op-amp gain
Voltage gain 2	G <sub>V2</sub>	0	—	dB	2nd Op-amp gain
Maximum output voltage1	V <sub>OM1</sub>	+6.0	+6.0	dBV	DSTN=1% ,BTL *1
Maximum output voltage2	V <sub>OM2</sub>	—	+5.1	dBV	V <sub>CC</sub> =3.4V,DSTN=1%,BTL *1
Output distortion	D <sub>STN</sub>	0.07	0.2	%	V <sub>IN</sub> =-20dB, V SE *1
Output noise level	V <sub>NO</sub>	-94	-94	dBV	No signal, SE Active mode *2
Suspend attenuation	G <sub>S</sub>	-107	-107	dBV	V <sub>IN</sub> =-20dB, V BTL *2
Bias setting voltage	V <sub>BIAS</sub>	1.8	1.8	V	3pin DC voltage
Suspend hold voltage / H	V <sub>SH1</sub>	V <sub>CC</sub> × 0.8 ~ V <sub>CC</sub>	2.0 ~ V <sub>CC</sub>	V	Active mode, Hold voltage
Suspend hold voltage / L	V <sub>SH2</sub>	0 ~ 0.5	0 ~ 0.5	V	Suspend mode, Hold voltage

\*1 : B.W.=0.4 ~ 30kHz

\*2 : DIN AUDIO

● Measurement circuit

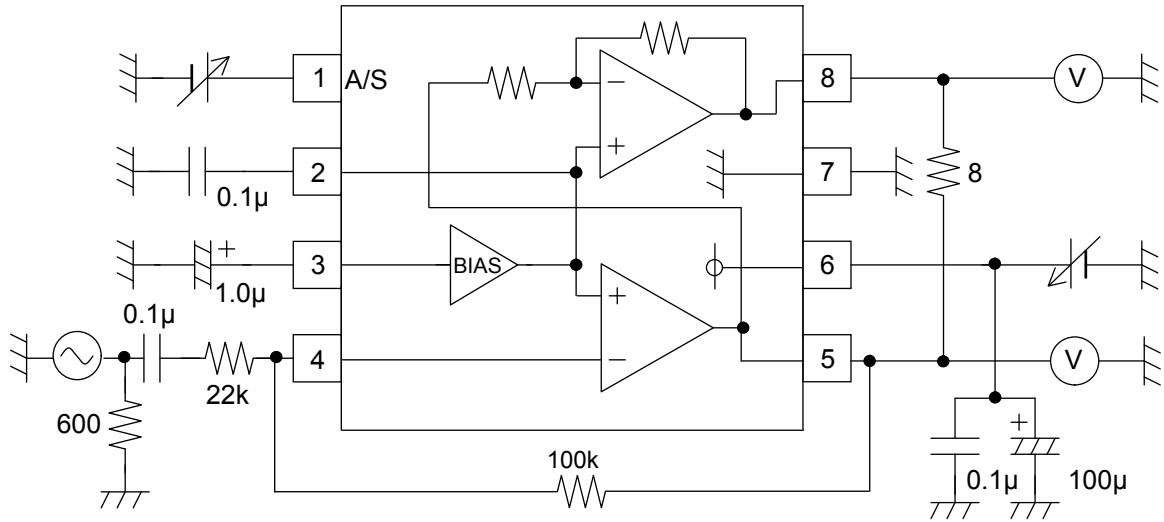

Fig.2 BH7824FVM

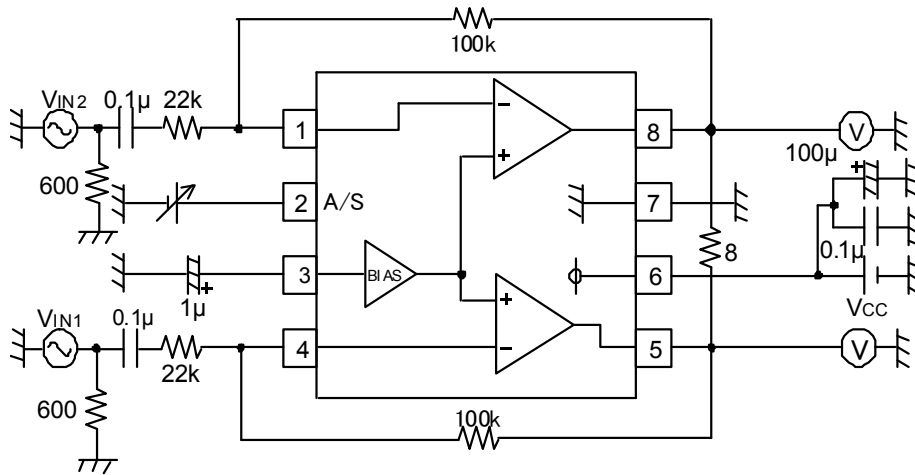

Fig.3 BH7826FVM

●Block diagram

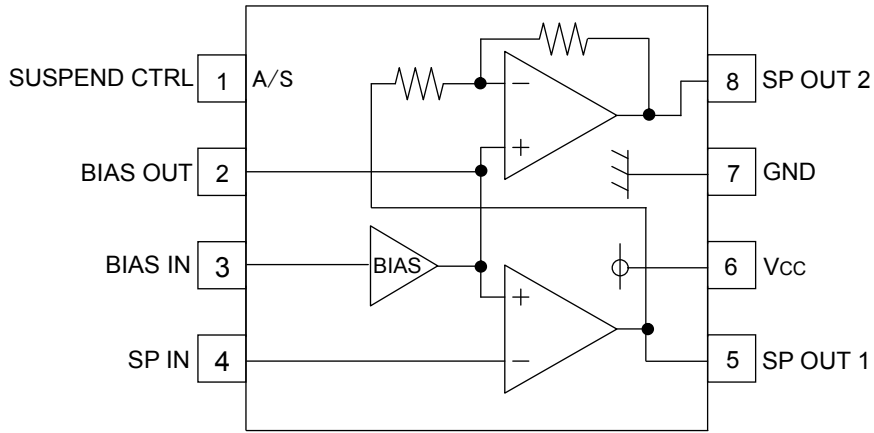

Fig.4 BH7824FVM

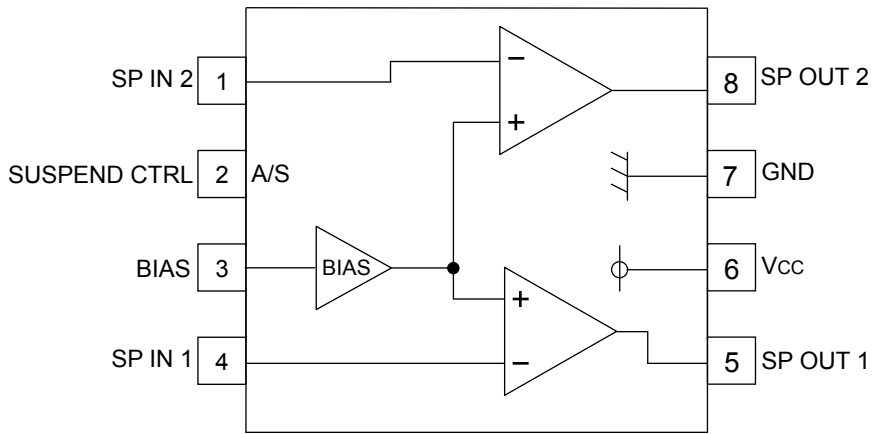
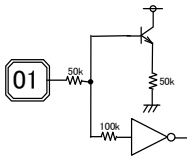
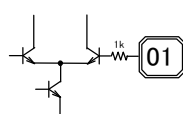
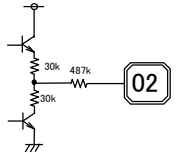
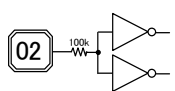
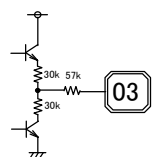
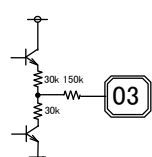
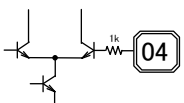
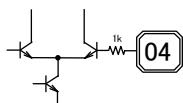
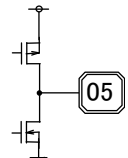
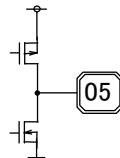
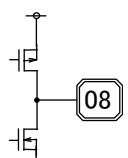
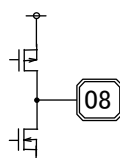

Fig.5 BH7826FVM

●Equivalent circuit

Pin No.	BH7824FVM		BH7826FVM	
	Pin name	Equivalent circuit	Pin name	Equivalent circuit
1	SUSPEND CTRL		SP IN2	
2	BIAS OUT		SUSPEND CTRL	
3	BIAS IN		BIAS IN	
4	SP IN		SP IN1	
5	SP OUT1		SP OUT1	
6	V <sub>CC</sub>	—	V <sub>CC</sub>	—
7	GND	—	GND	—
8	SP OUT2		SP OUT2	

Note: Numerical values in figures are design values, and do not guarantee ratings.

● Application circuit

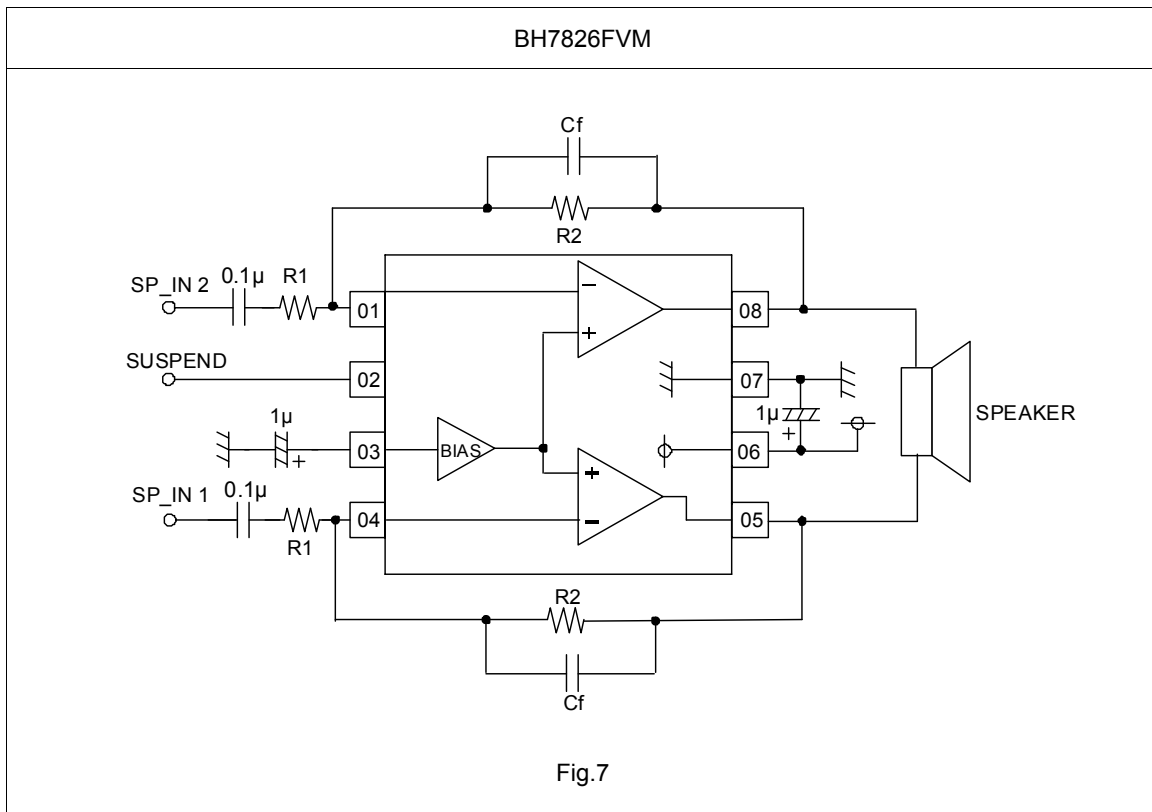
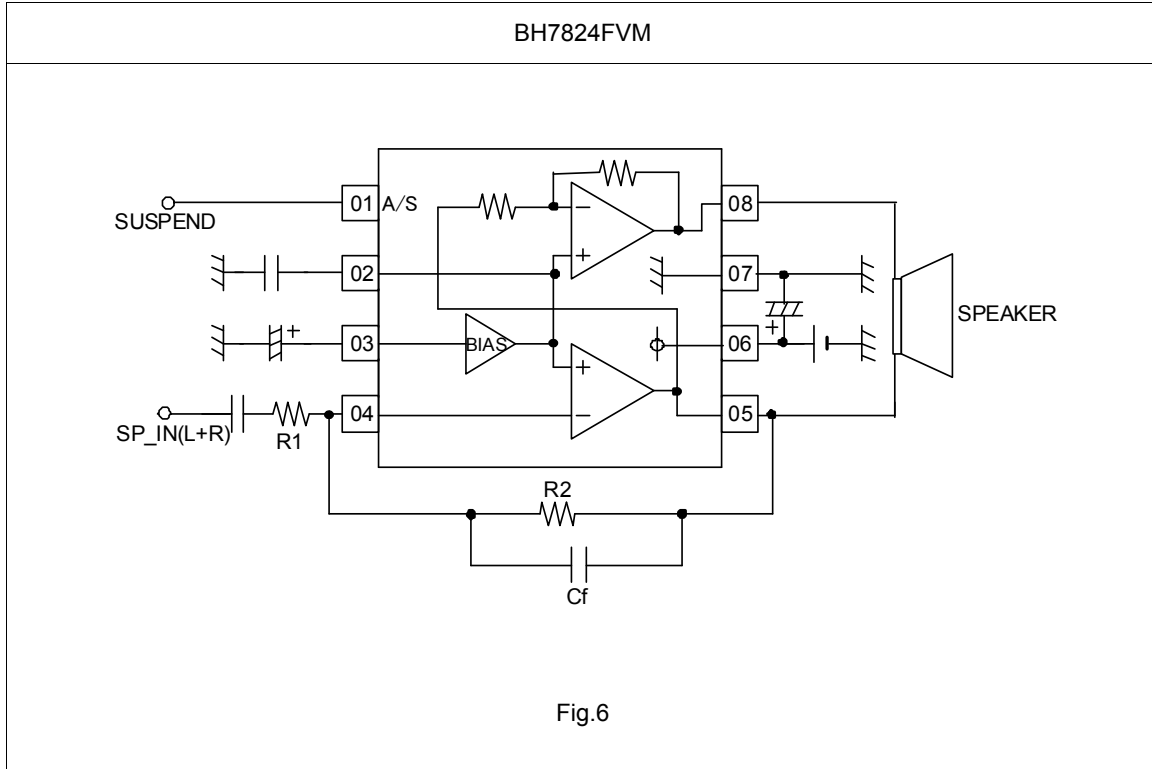

## ● Functions and Settings of external components

### 【Function of external components】

#### ① R1

R1 is an input resistor of inverting amplifier which determines closed loop gain with R2.

#### ② R2

R2 is a feedback resistor of inverting amplifier determine closed loop gain with R2. The gain is set by below expression.

$$\text{Gain(BTL)} = 20 \log_{10} \left\{ \frac{R2}{R1} \times \frac{1}{K_0 + K_1 \times \left( 1 + \frac{R2}{R1} \right) + K_2 \times R2} \right\}$$

※  $K_0, K_1, K_2$  are constants (Values below are reference values and not guaranteed values)

$$K_0 = 0.48, \quad K_1 = 6.96 \times 10^{-3}, \quad K_2 = 4.36 \times 10^{-7}$$

The expression above is a conversion formula to be checked and adjusted for the actual equipment.

#### ③ Cf

Cf is feedback capacitor to cut high frequency signals.

It forms a low-pass filter with R2. The cut-off frequency is calculated as below.

$$f_{cL} = \frac{1}{2\pi \times R2 \times Cf} \quad [\text{Hz}]$$

(注) R1, R2, Cf and  $f_{cL}$  has limits in below table. Please set these component values in the ranges.

	Ranges	
R1	$10\text{k}\Omega \leq R1 \leq 120\text{k}\Omega$	
R2	$47\text{k}\Omega \leq R2 \leq 120\text{k}\Omega$	
Cf	Gain > +6dB	$Cf \leq 560\text{pF}$
	$0 < \text{Gain} \leq +6\text{dB}$	$Cf \leq 270\text{pF}$
$f_{cL}$	$f_{cL} \geq 4\text{kHz}$	

#### ④ Cb1 (Cb2 is only BH7824FVM.)

The capacitors stabilize DC bias voltage.

	BH7824FVM	BH7826FVM
Cb1	$1\mu\text{F}$	$1\mu\text{F}$
Cb2	$0.1\mu\text{F}$	—

As Cb1 (or Cb2) becomes larger, power supply rejection ratio is improved but turn on time becomes longer.

As it becomes smaller, turn on time becomes shorter but power supply rejection ratio and cross talk become worse.

#### ⑤ Cin

It is Input coupling capacitor.

The value of the input capacitor directly affects the low frequency performance of the circuit.

The corner frequency of the high pass filter is determined in equation at ③ of next section.

**【Configuration of external components】**

- ① Gain  
Gain is designed by output power application ask for.  
Output power is determined to below.  
 $Po[W] = Vo^2[Vrms] / RL[\Omega]$   
 $Vo = Gv \cdot Vin$   
 $Gv \geq \sqrt{Po \cdot RL} / Vin$
- ② Values of R1 and R2  
R1 and R2 are determined to Av.  
 $Av = (R2 / R1) \times 2$   
Input impedance (R1) must be probable driven by signal source
- ③ Input coupling capacitor  
Corner frequency of HPF is determined in below.  
 $fc[Hz] = 1 / (2\pi \cdot R1 \cdot Cin)$   
Input coupling is solved by equation of fc.  
 $Cin \geq 1 / (2\pi \cdot R1 \cdot fc)$

**【instruction for use carefully】**

- ① Do not connect capacitive load has more than below capacitance between OUT1,2(5,8pin) and GND otherwise oscillation may occurred.

	8, 12Ω Speakers	16Ω speaker
	BH7824FVM / 26FVM	BH7824FVM
Co	Co ≤ 100pF	Co ≤ 47pF

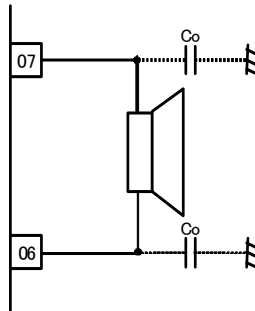

Fig.8 Output connections

- ② Do not use this IC without a load.
- ③ This IC is compatible with dynamic speaker loads (8~40Ω : BH7824FVM、8~12Ω : BH7826FVM) and is not compatible with loads other than these mentioned.
- ④ soft mute setting becomes effective on connecting a resistor and capacitor to the SUSPEND pin (1pin: BH7824FVM, 2pin: BH7826FVM).

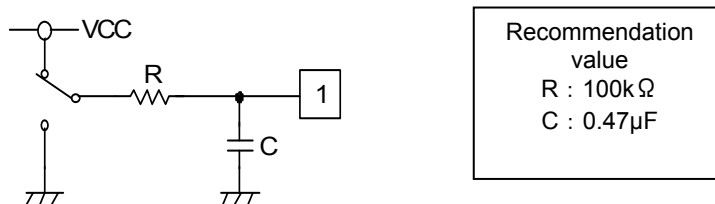

Fig.9 BH7824FVM application circuit for soft mute

- ⑤ Place the Vcc decoupling capacitor between VCC(6pin) and GND(7pin) as close to IC as possible.

● Typical characteristics (BH7824FVM)

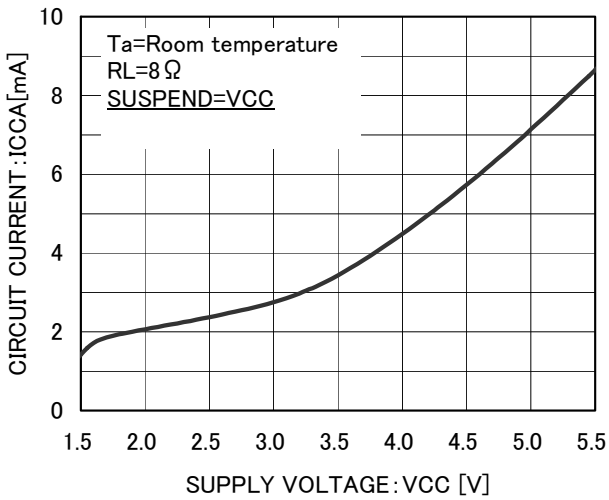

Fig.11 Circuit current (ACTIVE) — Power supply

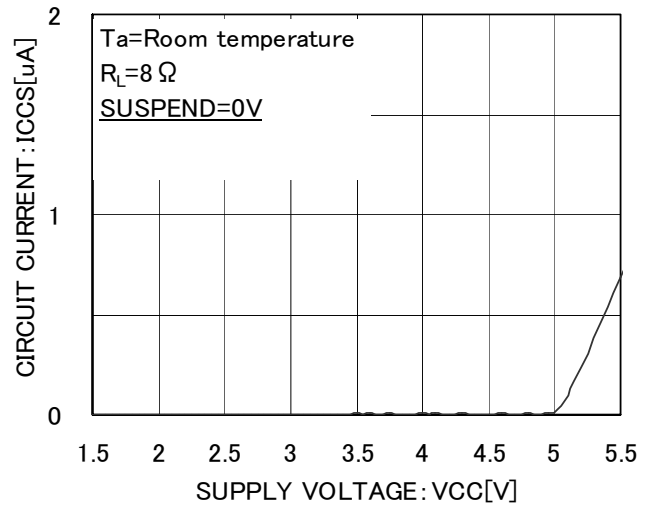

Fig.12 Circuit current (SUSPEND) — Power supply

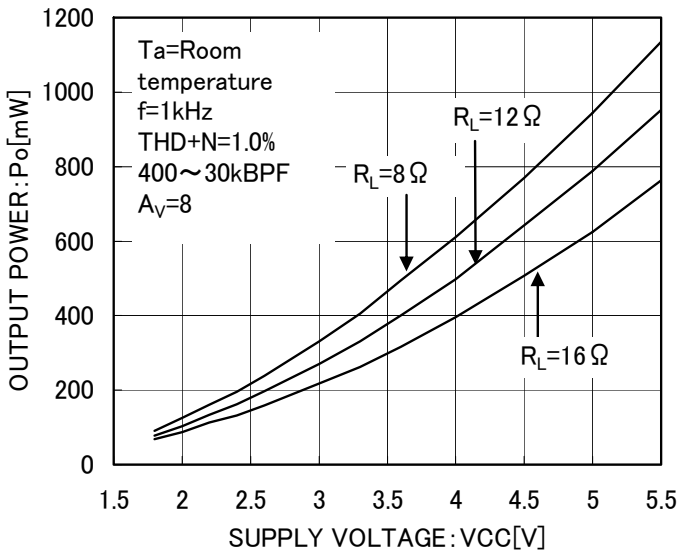

Fig.13 Output power — Power supply

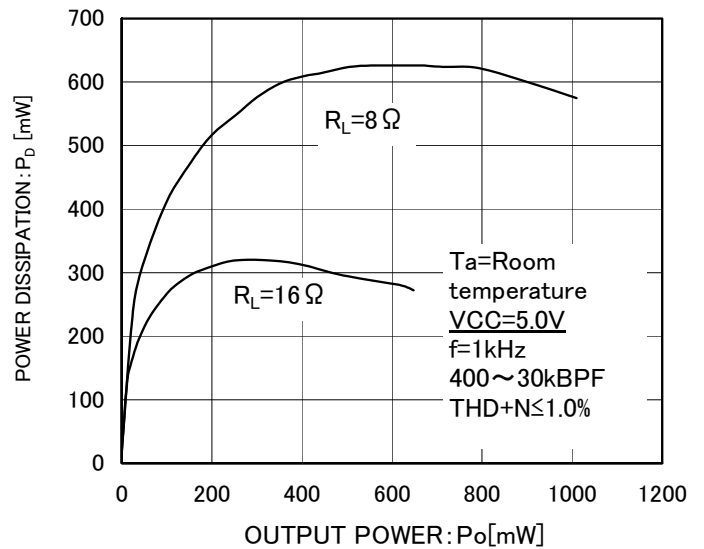

Fig.14 Power dissipation — Output power

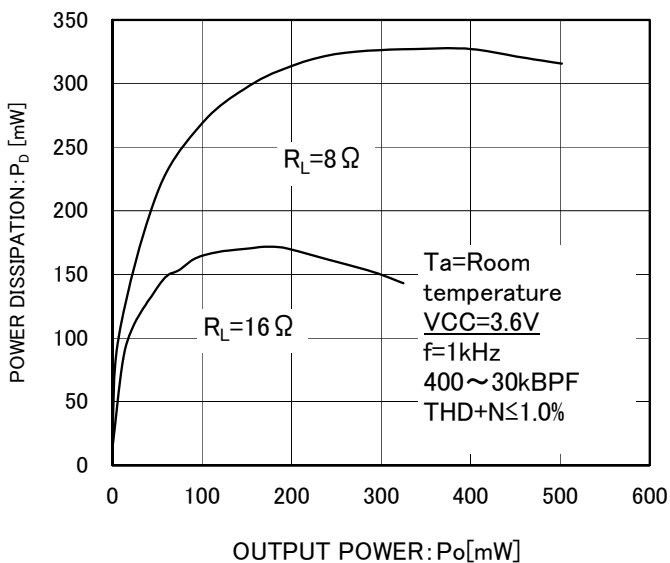

Fig.15 Power dissipation — Output power

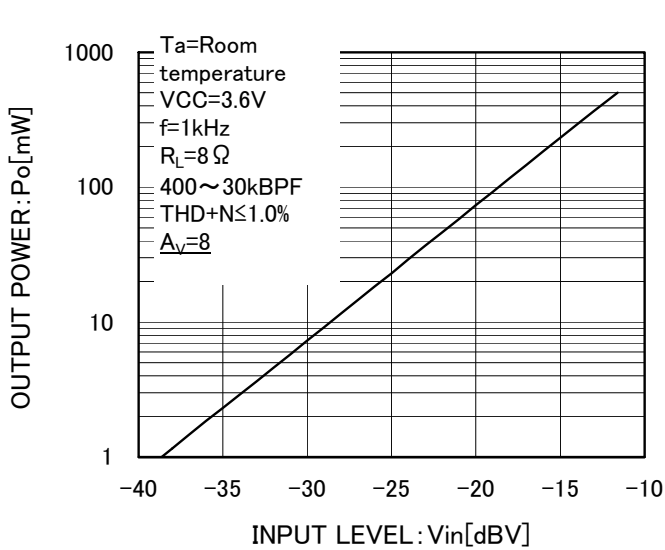

Fig.16 Output Power — Input level

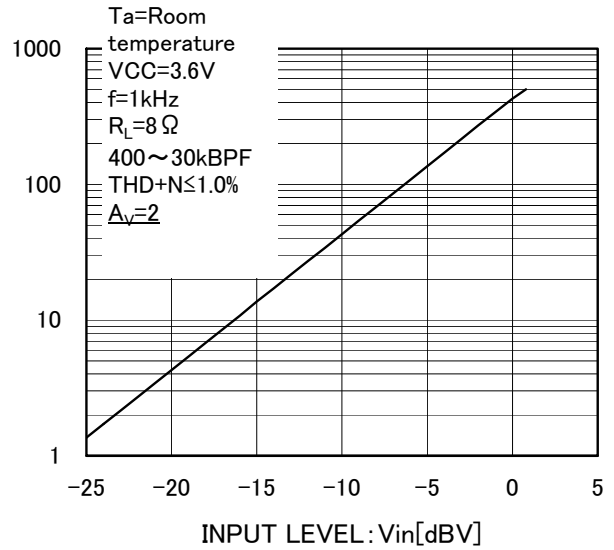

Fig.17 Output Power — Input level

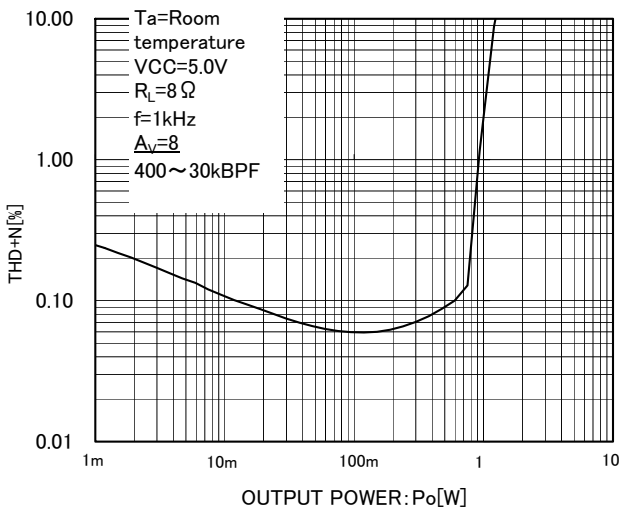

Fig.18 THD + Noise — Output Power

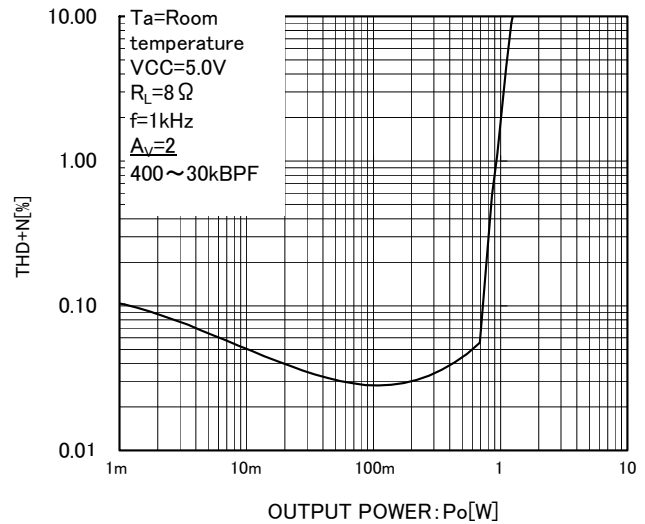

Fig.19 THD + Noise — Output Power

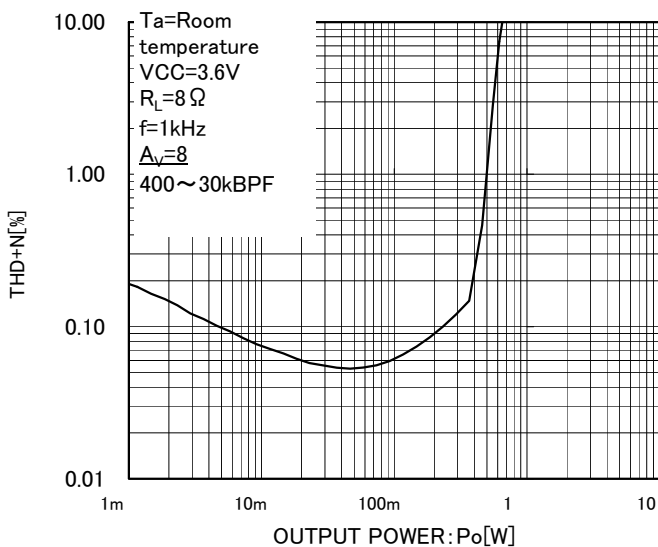

Fig.20 THD + Noise — Output Power

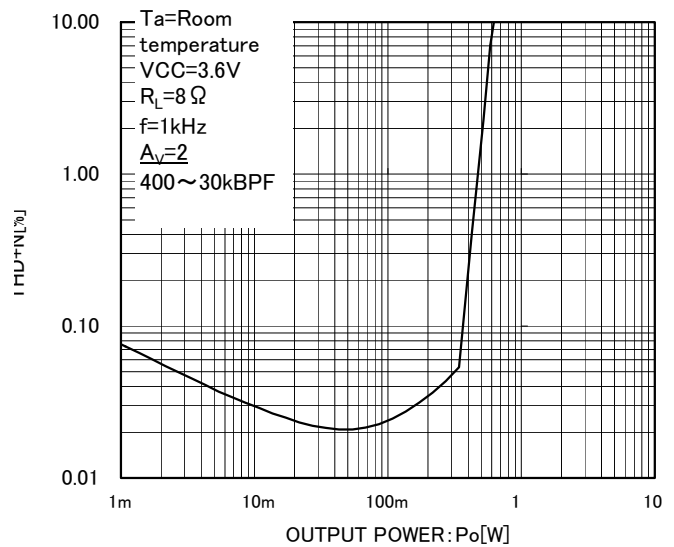

Fig.21 THD + Noise — Output Power

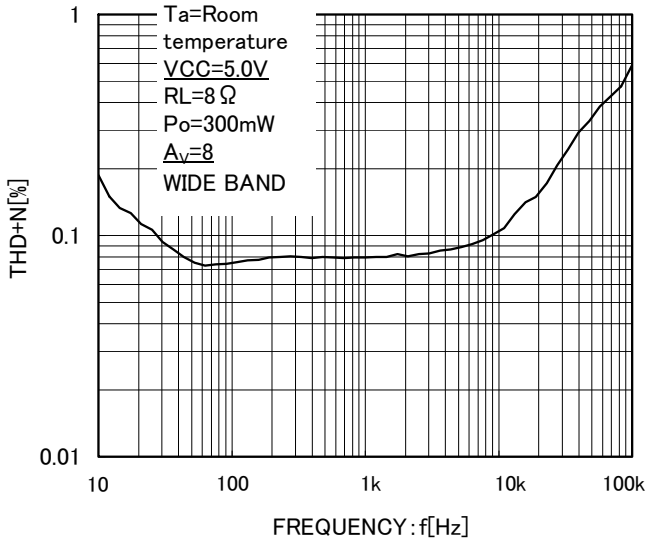

Fig.22 THD + N - Frequency

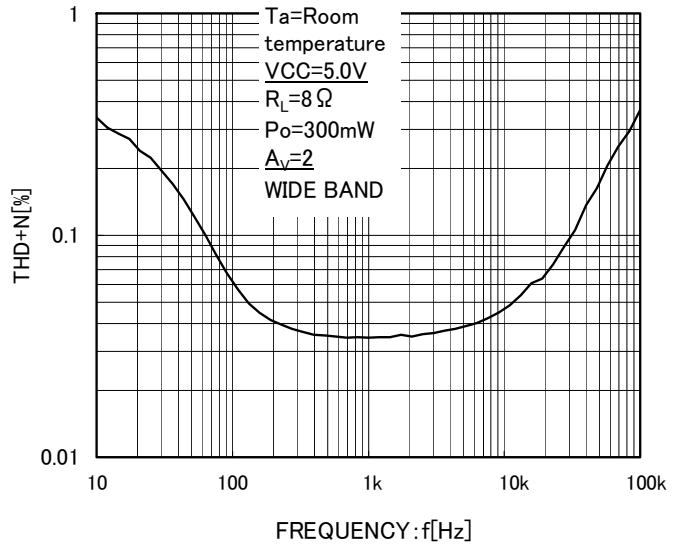

Fig.23 THD + N - Frequency

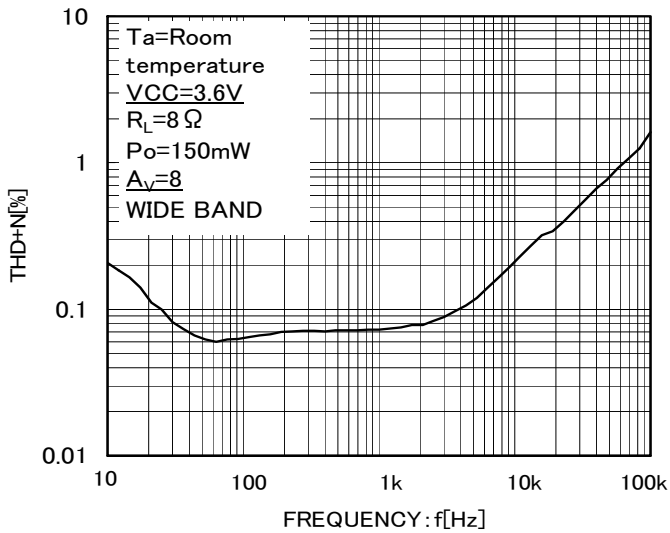

Fig.24 THD + N - Frequency

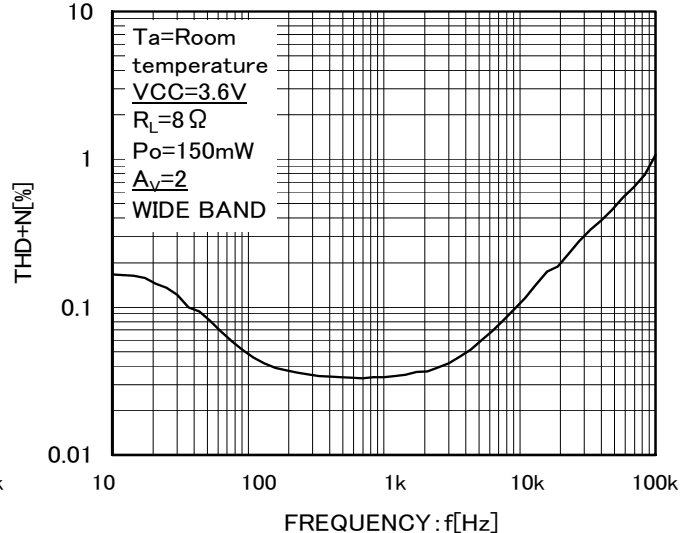

Fig.25 THD + N - Frequency

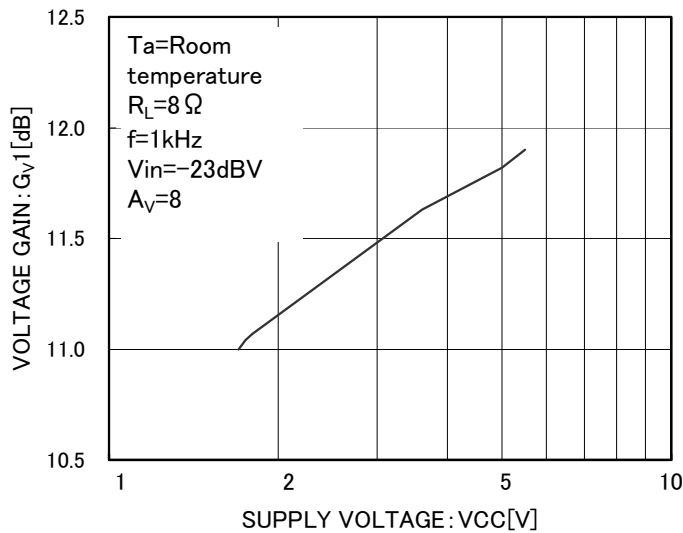

Fig.26 Gain(1stAmp) - Power supply

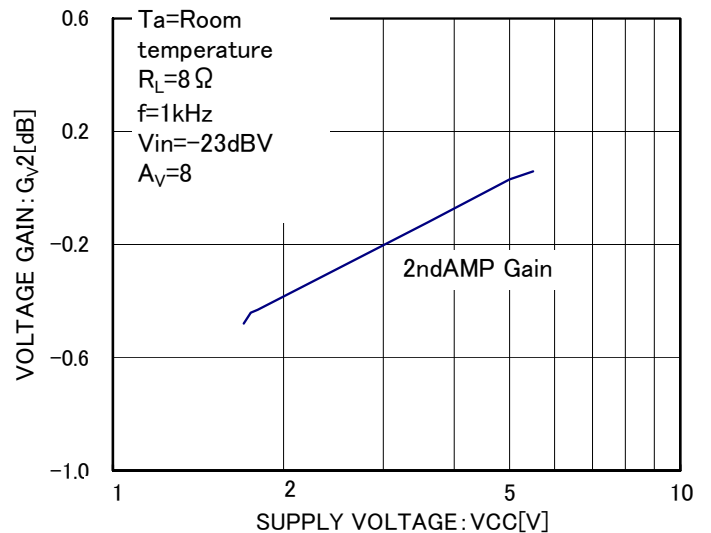

Fig.27 Gain(2ndAmp) - Power supply

※C1:The capacitor connected to SUSPEND terminal

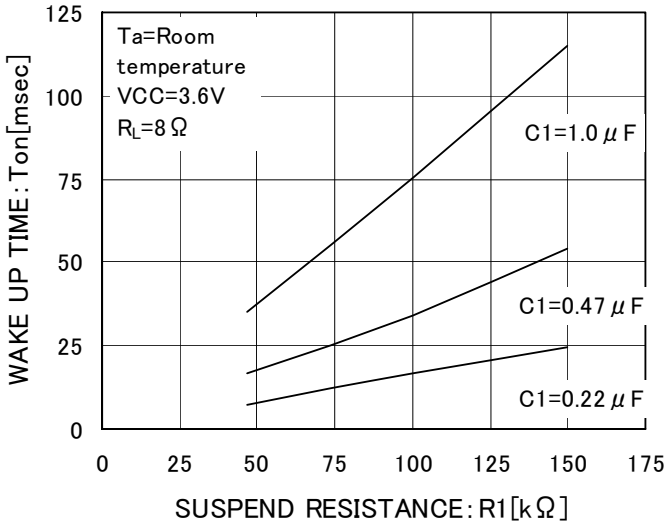

Fig.28 Wake up time — SUSPEND terminal resistance

※C1:The capacitor connected to SUSPEND terminal

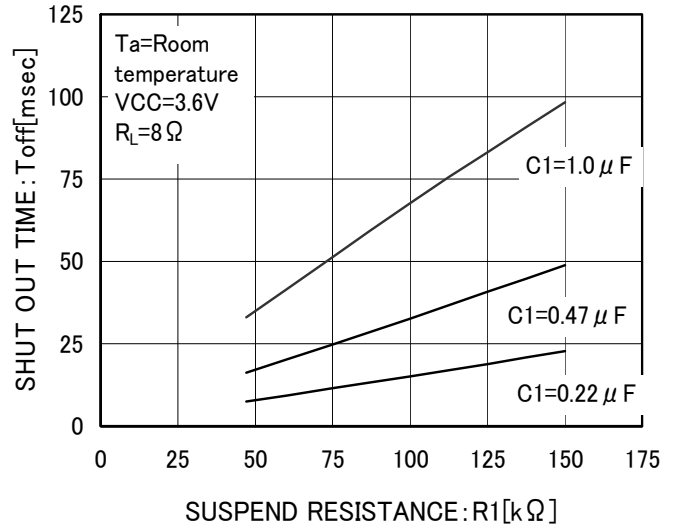

Fig.29 Shut out time — SUSPEND terminal resistance

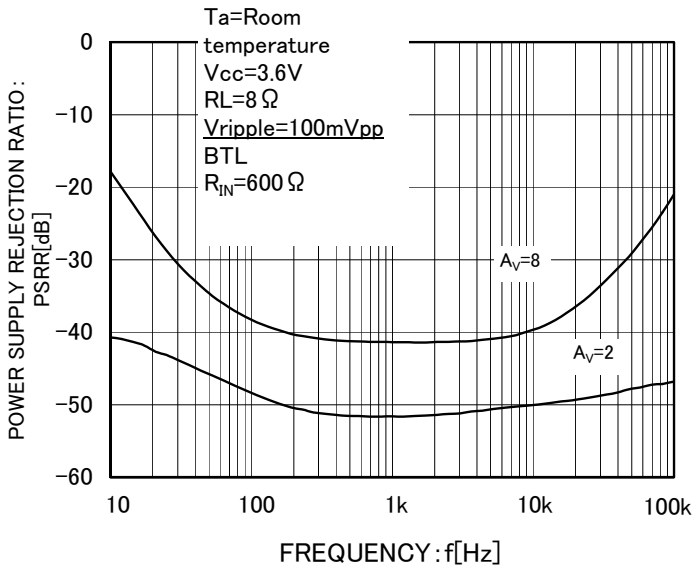

Fig.30 Power Supply Rejection Ratio — Frequency

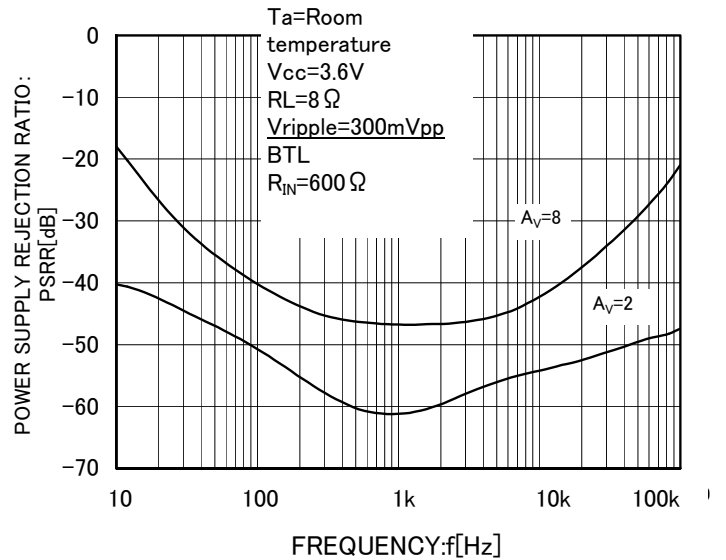
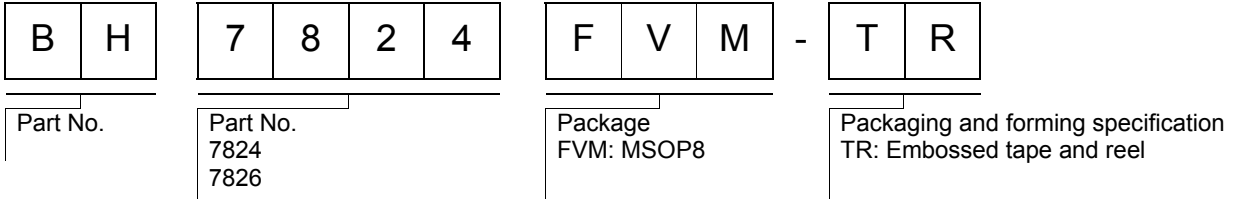

Fig.31 Power Supply Rejection Ratio — Frequency

## ●Notes for use

- 1) Numbers and data in entries are representative design values and are not guaranteed values of the items.
- 2) Although ROHM is confident that the example application circuit reflects the best possible recommendations, be sure to verify circuit characteristics for your particular application. Modification of constants for other externally connected circuits may cause variations in both static and transient characteristics for external components as well as this Rohm IC. Allow for sufficient margins when determining circuit constants.
- 3) Absolute maximum ratings  
Use of the IC in excess of absolute maximum ratings, such as the applied voltage or operating temperature range ( $T_{opr}$ ), may result in IC damage. Assumptions should not be made regarding the state of the IC (short mode or open mode) when such damage is suffered. A physical safety measure, such as a fuse, should be implemented when using the IC at times where the absolute maximum ratings may be exceeded.
- 4) GND potential  
Ensure a minimum GND pin potential in all operating conditions. Make sure that no pins are at a voltage below the GND at any time, regardless of whether it is a transient signal or not.
- 5) Thermal design  
Perform thermal design, in which there are adequate margins, by taking into account the permissible dissipation ( $P_d$ ) in actual states of use.
- 6) Short circuit between terminals and erroneous mounting  
Pay attention to the assembly direction of the ICs. Wrong mounting direction or shorts between terminals, GND, or other components on the circuits, can damage the IC.
- 7) Operation in strong electromagnetic field  
Using the ICs in a strong electromagnetic field can cause operation malfunction.

●Ordering part number



MSOP8

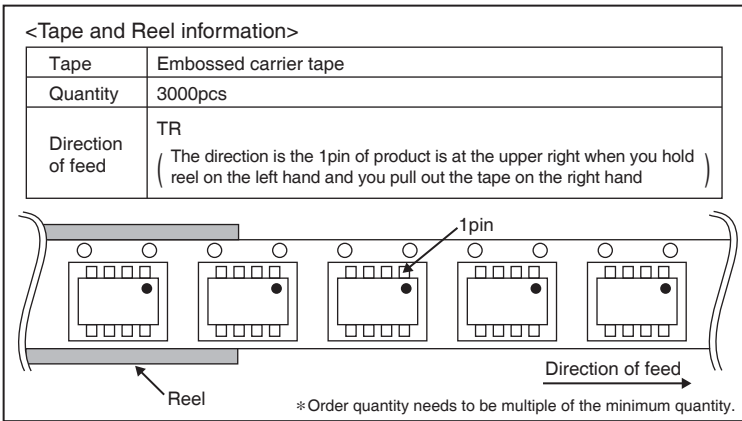
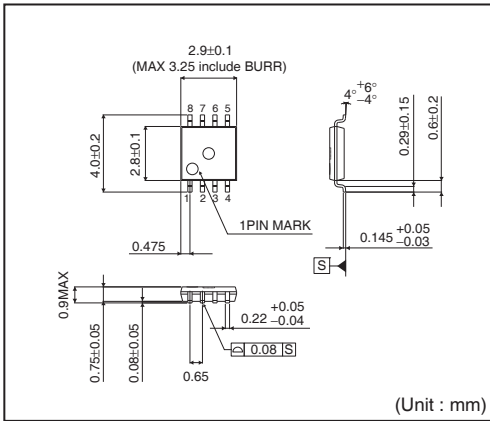

# Notice

## Precaution on using ROHM Products

- Our Products are designed and manufactured for application in ordinary electronic equipments (such as AV equipment, OA equipment, telecommunication equipment, home electronic appliances, amusement equipment, etc.). If you intend to use our Products in devices requiring extremely high reliability (such as medical equipment <sup>(Note 1)</sup>, transport equipment, traffic equipment, aircraft/spacecraft, nuclear power controllers, fuel controllers, car equipment including car accessories, safety devices, etc.) and whose malfunction or failure may cause loss of human life, bodily injury or serious damage to property ("Specific Applications"), please consult with the ROHM sales representative in advance. Unless otherwise agreed in writing by ROHM in advance, ROHM shall not be in any way responsible or liable for any damages, expenses or losses incurred by you or third parties arising from the use of any ROHM's Products for Specific Applications.

(Note1) Medical Equipment Classification of the Specific Applications

JAPAN	USA	EU	CHINA
CLASS III	CLASS III	CLASS II b	CLASS III
CLASS IV		CLASS III	

- ROHM designs and manufactures its Products subject to strict quality control system. However, semiconductor products can fail or malfunction at a certain rate. Please be sure to implement, at your own responsibilities, adequate safety measures including but not limited to fail-safe design against the physical injury, damage to any property, which a failure or malfunction of our Products may cause. The following are examples of safety measures:
  - Installation of protection circuits or other protective devices to improve system safety
  - Installation of redundant circuits to reduce the impact of single or multiple circuit failure
- Our Products are designed and manufactured for use under standard conditions and not under any special or extraordinary environments or conditions, as exemplified below. Accordingly, ROHM shall not be in any way responsible or liable for any damages, expenses or losses arising from the use of any ROHM's Products under any special or extraordinary environments or conditions. If you intend to use our Products under any special or extraordinary environments or conditions (as exemplified below), your independent verification and confirmation of product performance, reliability, etc. prior to use, must be necessary:
  - Use of our Products in any types of liquid, including water, oils, chemicals, and organic solvents
  - Use of our Products outdoors or in places where the Products are exposed to direct sunlight or dust
  - Use of our Products in places where the Products are exposed to sea wind or corrosive gases, including Cl<sub>2</sub>, H<sub>2</sub>S, NH<sub>3</sub>, SO<sub>2</sub>, and NO<sub>2</sub>
  - Use of our Products in places where the Products are exposed to static electricity or electromagnetic waves
  - Use of our Products in proximity to heat-producing components, plastic cords, or other flammable items
  - Sealing or coating our Products with resin or other coating materials
  - Use of our Products without cleaning residue of flux (even if you use no-clean type fluxes, cleaning residue of flux is recommended); or Washing our Products by using water or water-soluble cleaning agents for cleaning residue after soldering
  - Use of the Products in places subject to dew condensation
- The Products are not subject to radiation-proof design.
- Please verify and confirm characteristics of the final or mounted products in using the Products.
- In particular, if a transient load (a large amount of load applied in a short period of time, such as pulse. is applied, confirmation of performance characteristics after on-board mounting is strongly recommended. Avoid applying power exceeding normal rated power; exceeding the power rating under steady-state loading condition may negatively affect product performance and reliability.
- De-rate Power Dissipation (Pd) depending on Ambient temperature (Ta). When used in sealed area, confirm the actual ambient temperature.
- Confirm that operation temperature is within the specified range described in the product specification.
- ROHM shall not be in any way responsible or liable for failure induced under deviant condition from what is defined in this document.

## Precaution for Mounting / Circuit board design

- When a highly active halogenous (chlorine, bromine, etc.) flux is used, the residue of flux may negatively affect product performance and reliability.
- In principle, the reflow soldering method must be used on a surface-mount products, the flow soldering method must be used on a through hole mount products. If the flow soldering method is preferred on a surface-mount products, please consult with the ROHM representative in advance.

For details, please refer to ROHM Mounting specification

**Precautions Regarding Application Examples and External Circuits**

1. If change is made to the constant of an external circuit, please allow a sufficient margin considering variations of the characteristics of the Products and external components, including transient characteristics, as well as static characteristics.
2. You agree that application notes, reference designs, and associated data and information contained in this document are presented only as guidance for Products use. Therefore, in case you use such information, you are solely responsible for it and you must exercise your own independent verification and judgment in the use of such information contained in this document. ROHM shall not be in any way responsible or liable for any damages, expenses or losses incurred by you or third parties arising from the use of such information.

**Precaution for Electrostatic**

This Product is electrostatic sensitive product, which may be damaged due to electrostatic discharge. Please take proper caution in your manufacturing process and storage so that voltage exceeding the Products maximum rating will not be applied to Products. Please take special care under dry condition (e.g. Grounding of human body / equipment / solder iron, isolation from charged objects, setting of Ionizer, friction prevention and temperature / humidity control).

**Precaution for Storage / Transportation**

1. Product performance and soldered connections may deteriorate if the Products are stored in the places where:
  - [a] the Products are exposed to sea winds or corrosive gases, including Cl<sub>2</sub>, H<sub>2</sub>S, NH<sub>3</sub>, SO<sub>2</sub>, and NO<sub>2</sub>
  - [b] the temperature or humidity exceeds those recommended by ROHM
  - [c] the Products are exposed to direct sunshine or condensation
  - [d] the Products are exposed to high Electrostatic
2. Even under ROHM recommended storage condition, solderability of products out of recommended storage time period may be degraded. It is strongly recommended to confirm solderability before using Products of which storage time is exceeding the recommended storage time period.
3. Store / transport cartons in the correct direction, which is indicated on a carton with a symbol. Otherwise bent leads may occur due to excessive stress applied when dropping of a carton.
4. Use Products within the specified time after opening a humidity barrier bag. Baking is required before using Products of which storage time is exceeding the recommended storage time period.

**Precaution for Product Label**

QR code printed on ROHM Products label is for ROHM's internal use only.

**Precaution for Disposition**

When disposing Products please dispose them properly using an authorized industry waste company.

**Precaution for Foreign Exchange and Foreign Trade act**

Since concerned goods might be fallen under listed items of export control prescribed by Foreign exchange and Foreign trade act, please consult with ROHM in case of export.

**Precaution Regarding Intellectual Property Rights**

1. All information and data including but not limited to application example contained in this document is for reference only. ROHM does not warrant that foregoing information or data will not infringe any intellectual property rights or any other rights of any third party regarding such information or data.
2. ROHM shall not have any obligations where the claims, actions or demands arising from the combination of the Products with other articles such as components, circuits, systems or external equipment (including software).
3. No license, expressly or implied, is granted hereby under any intellectual property rights or other rights of ROHM or any third parties with respect to the Products or the information contained in this document. Provided, however, that ROHM will not assert its intellectual property rights or other rights against you or your customers to the extent necessary to manufacture or sell products containing the Products, subject to the terms and conditions herein.

**Other Precaution**



1. This document may not be reprinted or reproduced, in whole or in part, without prior written consent of ROHM.
2. The Products may not be disassembled, converted, modified, reproduced or otherwise changed without prior written consent of ROHM.
3. In no event shall you use in any way whatsoever the Products and the related technical information contained in the Products or this document for any military purposes, including but not limited to, the development of mass-destruction weapons.
4. The proper names of companies or products described in this document are trademarks or registered trademarks of ROHM, its affiliated companies or third parties.

**General Precaution**

1. Before you use our Products, you are requested to carefully read this document and fully understand its contents. ROHM shall not be in any way responsible or liable for failure, malfunction or accident arising from the use of any ROHM's Products against warning, caution or note contained in this document.
2. All information contained in this document is current as of the issuing date and subject to change without any prior notice. Before purchasing or using ROHM's Products, please confirm the latest information with a ROHM sales representative.
3. The information contained in this document is provided on an "as is" basis and ROHM does not warrant that all information contained in this document is accurate and/or error-free. ROHM shall not be in any way responsible or liable for any damages, expenses or losses incurred by you or third parties resulting from inaccuracy or errors of or concerning such information.

## Looking for pricing, stock, or lifecycle information?

Click below to explore more details on WIN SOURCE:

-  [View BH7824FVM-FTR on WIN SOURCE](#)
-  [Rohm Semiconductor](#) Information

## Optimize Your Supply Chain with WIN SOURCE Solutions

-  Global Sourcing Solution
-  Obsolete Management
-  Cost Control Management
-  Shortage Management
-  Alternative Solution
-  Excess Inventory Management