



THE DATASHEET OF BH7600AFS



STRUCTURE Silicon Monolithic Integrated Circuit

PRODUCTS 3ch Video driver for digital STB

TYPE **B H 7 6 0 0 A F S**

PACKAGE S S O P — A 2 4

FEATURES

- 1) Pedestal clamp input with sync mix
- 2) Built in 3ch Inside DC output circuit for D connector control line
- 3) Built in inside D connector connection detect
- 4) I²C-BUS control
- 5) Inside output mute circuit

■ Absolute Maximum Ratings (Ta=25°C)

Parameter	Symbol	Rating	Unit
Power supply Voltage	VCC	7.0	V
Power Dissipation	Pd	800	mW
Input Voltage Range	Vin	0~VCC	V
Operating Temperature Range	Topr	-25~+75	°C
Storage Temperature Range	Tstg	-55~+125	°C

※When absolute temperature exceeds Ta=25°C, the rated value is reduced by 8.0mW/°C.

■ Operating Voltage Ratings

Parameter	Symbol	Min.	Typ.	Max.	Unit
Operation power supply Voltage	VCC	4.5	5.0	5.5	V

※ This product is not designed for protection against radioactive rays.

Status of this document

The Japanese version of this document is the formal specification.

A customer may use this translation version only for a reference to help reading the formal version.

If there are any differences in translation version of this document, formal version takes priority.

Application example

- ROHM cannot provide adequate confirmation of patents.
- The product described in this specification is designed to be used with ordinary electronic equipment or devices (such as audio-visual equipment, office-automation equipment, communications devices, electrical appliances, and electronic toys). Should you intend to use this product with equipment or devices which require an extremely high level of reliability and the malfunction of which would directly endanger human life (such as medical instruments, transportation equipment, aerospace machinery, nuclear-reactor controllers, fuel controllers and other safety devices), please be sure to consult with our sales representative in advance.
- ROHM assumes no responsibility for use of any circuits described herein, conveys no license under any patent or other right, and makes no representations that the circuits are free from patent infringement.

■ Electrical characteristics 【Unless otherwise specified, Ta=25°C, VCC=5V】

Parameter	Symbol	Limit			Unit	Conditions
		Min	Typ	Max		
《All Circuits》						
Circuit Current	I _{CC}	10.8	21.5	32.3	mA	No signal
LINEOUT [H] Voltage	V _{LOH}	4.0	4.9	5.0	V	
LINEOUT [M] Voltage	V _{LOM}	1.5	1.9	2.3	V	
LINEOUT [L] Voltage	V _{LOL}	0.0	0.2	0.5	V	
LINEOUT Impedance	Z _{LO}	1.3	1.8	2.3	kΩ	
《Video Driver Parts》						
Voltage Gain	G _V	-1	-0.5	0	dB	V _{IN} =1Vp-p, f=1MHz
Frequency Characteristics	V _{F1}	-1	0	1	dB	V _{IN} =1Vp-p, f=1M/10MHz
MUTE Input Impedance	Z _{IN}	75	100	125	kΩ	
MUTE [H] Level Input Voltage	V _{MH}	2.0	—	VCC	V	
MUTE [L] Level Input Voltage	V _{ML}	0	—	1.0	V	
《SYNC》						
SYNC1, 2 [H] Level Input Voltage	V _{SYNH}	2.0	—	VCC	V	
SYNC1, 2 [L] Level Input Voltage	V _{SYNL}	0	—	—	V	
SYNC Input Bias Current	I _{SYN}	-20	-2.0	0	uA	
SYNC Mix Level	V _{SYL}	270	300	330	mV	
《Control Part》						
[H] Level Input Voltage	V _H	2.0	—	VCC	V	
[L] Level Input Voltage	V _L	0	—	1.0	V	
SDA [L] Sync Current	I _{SIN}	4.0	—	—	mA	
DET Detection Level [H]	V _{DH}	2.0	—	VCC	V	
DET Detection Level [L]	V _{DL}	0	—	1.0	V	
DET Input Bias Current	I _{DET}	-20	-2.0	0	uA	

■ Outer Dimensions

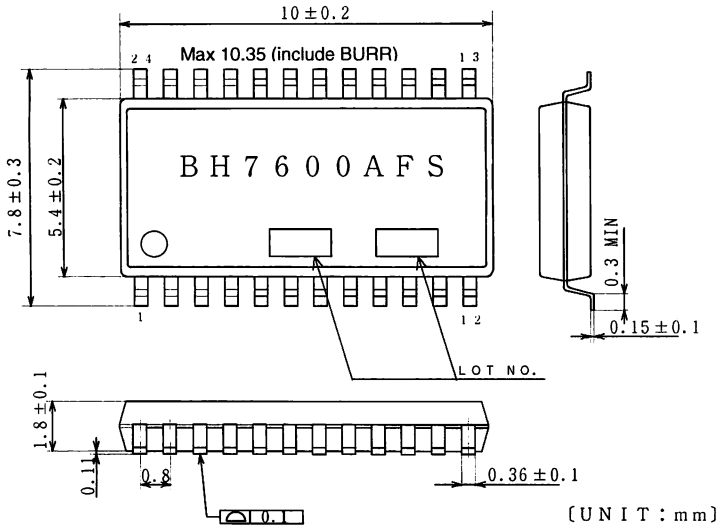

PKG : SSOP-A24

■ Block Diagram

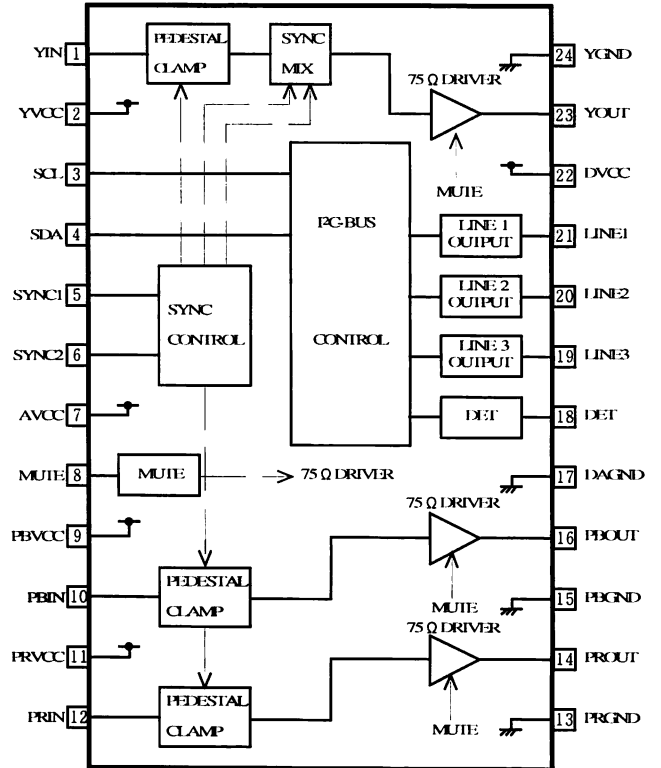

■ PIN number and Pin name

Pin No.	Pin Name	Pin No.	Pin Name
1	YIN	13	PRGND
2	YVCC	14	PROUT
3	SCL	15	PBGND
4	SDA	16	PBOUT
5	SYNC1	17	DAGND
6	SYNC2	18	DET
7	AVCC	19	LINE3
8	MUTE	20	LINE2
9	PBVCC	21	LINE1
10	PBIN	22	DVCC
11	PRVCC	23	YOUT
12	PRIN	24	YGND

■ Caution On Use

- (1) Numbers and data in entries are representative design values and are not guaranteed values of the items.
- (2) Absolute maximum ratings
If applied voltage, operating temperature range, or other absolute maximum ratings are exceeded, the LSI may be damaged. Do not apply voltages or temperatures that exceeded the absolute maximum ratings. If you think of a case in which absolute maximum ratings are exceeded, enforce fuses or other physical safety measures and investigate how not to apply the conditions under which absolute maximum ratings are exceeded to the LSI.
- (3) GND potential
Make the GND pin voltage such that it is the lowest voltage even when operating below it. Actually confirm that the voltage of each pin does not become a lower voltage than the GND pin, including transient phenomena.
- (4) Thermal design
Perform thermal design in which there are adequate margins by taking into account the allowable power dissipation in actual states of use.
- (5) Shorts between pins and misinstallation
When mounting the LSI on a board, pay adequate attention to orientation and placement discrepancies of the LSI. If it is misinstalled and the power is turned on, the LSI may be damaged. It also may be damaged if it is shorted by a foreign substance coming between pins of the LSI or between a pin and a power supply or a pin and a GND.
- (6) Operation in strong magnetic fields
Adequately evaluate use in a strong magnetic, since there is a possibility of malfunction.
- (7) Supply voltage of operation
Although proper operation is guaranteed within the range of supply voltage (4.5V~5.5V) provided that each element functions properly and applied parameters are correct.
- (8) Place the first resistor near the driver output of the IC.
- (9) Place coupling capacitor near the pins as possible.
- (10) VCC for this IC should use the same power source. And impedance should connect as well as possible for each VCC pin, for each GND pin.

Notes

- No technical content pages of this document may be reproduced in any form or transmitted by any means without prior permission of ROHM CO.,LTD.
- The contents described herein are subject to change without notice. The specifications for the product described in this document are for reference only. Upon actual use, therefore, please request that specifications to be separately delivered.
- Application circuit diagrams and circuit constants contained herein are shown as examples of standard use and operation. Please pay careful attention to the peripheral conditions when designing circuits and deciding upon circuit constants in the set.
- Any data, including, but not limited to application circuit diagrams information, described herein are intended only as illustrations of such devices and not as the specifications for such devices. ROHM CO.,LTD. disclaims any warranty that any use of such devices shall be free from infringement of any third party's intellectual property rights or other proprietary rights, and further, assumes no liability of whatsoever nature in the event of any such infringement, or arising from or connected with or related to the use of such devices.
- Upon the sale of any such devices, other than for buyer's right to use such devices itself, resell or otherwise dispose of the same, no express or implied right or license to practice or commercially exploit any intellectual property rights or other proprietary rights owned or controlled by
- ROHM CO., LTD. is granted to any such buyer.
- Products listed in this document are no antiradiation design.

The products listed in this document are designed to be used with ordinary electronic equipment or devices (such as audio visual equipment, office-automation equipment, communications devices, electrical appliances and electronic toys).

Should you intend to use these products with equipment or devices which require an extremely high level of reliability and the malfunction of which would directly endanger human life (such as medical instruments, transportation equipment, aerospace machinery, nuclear-reactor controllers, fuel controllers and other safety devices), please be sure to consult with our sales representative in advance.

About Export Control Order in Japan

Products described herein are the objects of controlled goods in Annex 1 (Item 16) of Export Trade Control Order in Japan.

In case of export from Japan, please confirm if it applies to "objective" criteria or an "informed" (by MITI clause) on the basis of "catch all controls for Non-Proliferation of Weapons of Mass Destruction.

Thank you for your accessing to ROHM product informations.
More detail product informations and catalogs are available,
please contact your nearest sales office.

Please contact our sales offices for details ;

U.S.A / San Diego	TEL : +1(858)625-3630	FAX : +1(858)625-3670
Atlanta	TEL : +1(770)754-5972	FAX : +1(770)754-0691
Dallas	TEL : +1(972)312-8818	FAX : +1(972)312-0330
Germany / Dusseldorf	TEL : +49(2154)9210	FAX : +49(2154)921400
United Kingdom / London	TEL : +44(1)908-282-666	FAX : +44(1)908-282-528
France / Paris	TEL : +33(0)1 56 97 30 60	FAX : +33(0) 1 56 97 30 80
China / Hong Kong	TEL : +852(2)740-6262	FAX : +852(2)375-8971
Shanghai	TEL : +86(21)6279-2727	FAX : +86(21)6247-2066
Dilian	TEL : +86(411)8230-8549	FAX : +86(411)8230-8537
Beijing	TEL : +86(10)8525-2483	FAX : +86(10)8525-2489
Taiwan / Taipei	TEL : +866(2)2500-6956	FAX : +866(2)2503-2869
Korea / Seoul	TEL : +82(2)8182-700	FAX : +82(2)8182-715
Singapore	TEL : +65-6332-2322	FAX : +65-6332-5662
Malaysia / Kuala Lumpur	TEL : +60(3)7958-8355	FAX : +60(3)7958-8377
Philippines / Manila	TEL : +63(2)807-6872	FAX : +63(2)809-1422
Thailand / Bangkok	TEL : +66(2)254-4890	FAX : +66(2)256-6334

Japan /
(Internal Sales)



Tokyo	2-1-1, Yaesu, Chuo-ku, Tokyo 104-0082	TEL : +81(3)5203-0321	FAX : +81(3)5203-0300
Yokohama	2-4-8, Shin Yokohama, Kohoku-ku, Yokohama, Kanagawa 222-8575	TEL : +81(45)476-2131	FAX : +81(45)476-2128
Nagoya	Dainagayo Building 9F 3-28-12, Meieki, Nakamura-ku, Nagoya, Aichi 450-0002	TEL : +81(52)581-8521	FAX : +81(52)561-2173
Kyoto	579-32 Higashi Shiokouji-cho, Karasuma Nishi-iru, Shiokoujidori, Shimogyo-ku, Kyoto 600-8216	TEL : +81(75)311-2121	FAX : +81(75)314-6559

(Contact address for overseas customers in Japan)







Yokohama	TEL : +81(45)476-9270	FAX : +81(045)476-9271
----------	-----------------------	------------------------

Looking for pricing, stock, or lifecycle information?

Click below to explore more details on WIN SOURCE:

-  [View BH7600AFS on WIN SOURCE](#)
-  [Rohm Semiconductor](#) Information

Optimize Your Supply Chain with WIN SOURCE Solutions

-  Global Sourcing Solution
-  Obsolete Management
-  Cost Control Management
-  Shortage Management
-  Alternative Solution
-  Excess Inventory Management