



**THE DATASHEET OF
AS4C128M16MD2A-25BIN**



Revision History

2G (128M x 16 and 64M x 32) Low Power DDR2 SDRAM 134ball FBGA
Package **AS4C128M16MD2A-25BIN/AS4C64M32MD2A-25BIN**

| Revision | Details | Date |
|----------|-----------------------|----------|
| Rev 1.0 | Preliminary datasheet | Jan 2018 |

DDR2 Sync DRAM Features

• Functionality

- VDD2 = 1.14–1.30V
- VDDCA/VDDQ = 1.14–1.30V
- VDD1 = 1.70–1.95V
- Interface : HSUL_12
- Data width : x16 / x32
- Clock frequency range : max 400MHz
- Four-bit pre-fetch DDR architecture
- Eight internal banks for concurrent operation
- Multiplexed, double data rate, command/address inputs; commands entered on every CK edge
- Bidirectional/differential data strobe per byte of data(DQS/DQS#).
- DM masks write data at the both rising and falling edge of the data strobe
- Programmable READ and WRITE latencies (RL/WL)
- Programmable burst lengths: 4, 8, or 16
- Auto refresh and self refresh supported
- All bank auto refresh and per bank auto refresh supported
- Clock stop capability

• Configuration

- 128 Meg X 16 (16 Meg X 16 X 8 Banks).
- 64 Meg X 32 (8 Meg X 32 X 8 Banks).

• Low Power Features

- Low voltage power supply.
- Auto TCSR (Temperature Compensated Self Refresh).
- PASR (Partial Array Self Refresh) power-saving mode.
- DPD (Deep Power Down) Mode.
- DS (Driver Strength) Control.

• Timing – Cycle time

- 1.875ns @ RL = 8
- 2.5ns @ RL = 6
- 3.0ns @ RL = 5

• Operating Temperature Ranges

- Industrial (-40°C to +85°C).

• Package

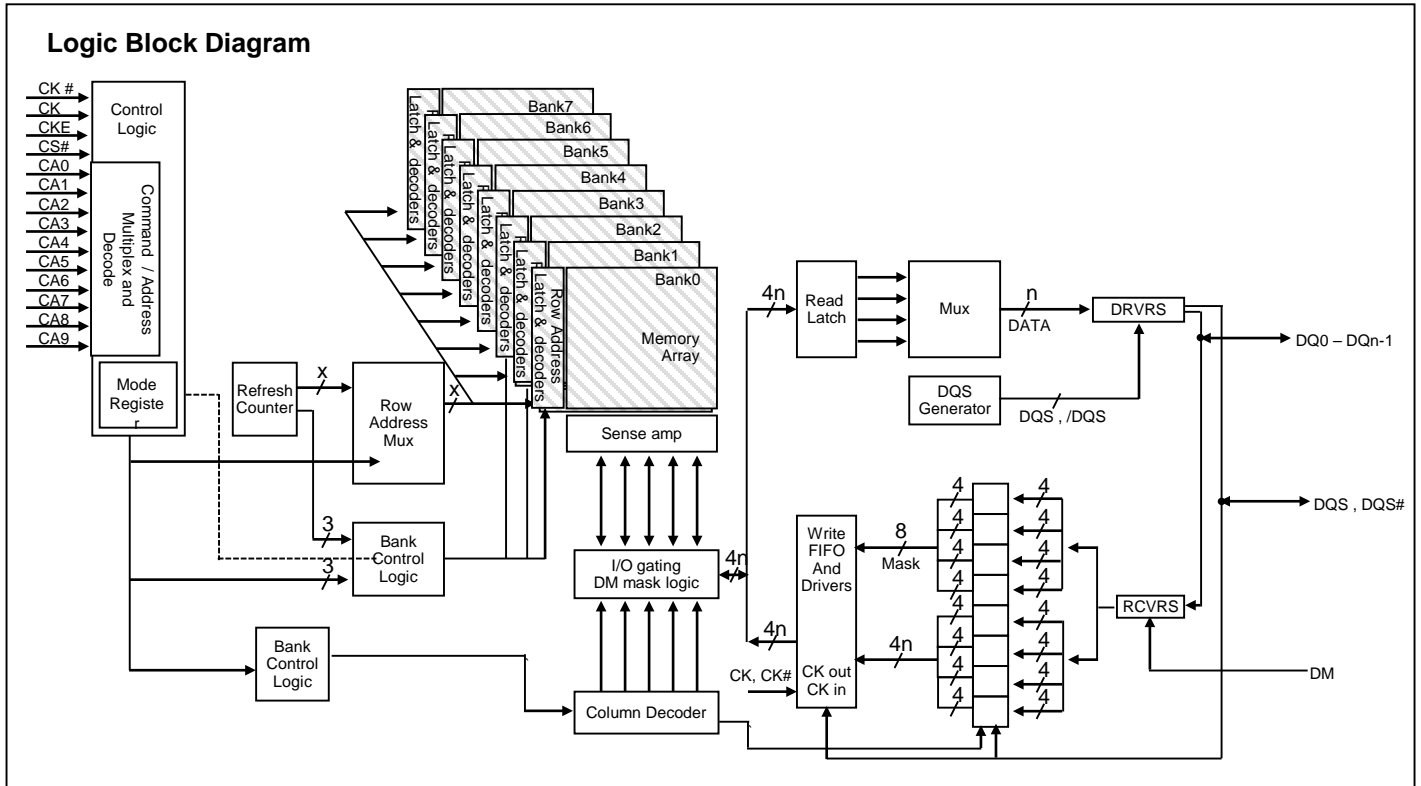
- 134-Ball FBGA(10.0mm x 11.5mm x 1.0mm)

Table 1. Ordering Information

| Product Part No. | Org. | Temperature | Max Clock (MHz) | Package |
|----------------------|-----------|---------------|-----------------|---------------|
| AS4C128M16MD2A-25BIN | 128M x 16 | -40°C to 85°C | 400 | 134-ball FBGA |
| AS4C64M32MD2A-25BIN | 64M x 32 | -40°C to 85°C | 400 | 134-ball FBGA |

Table 2. Speed Grade Information

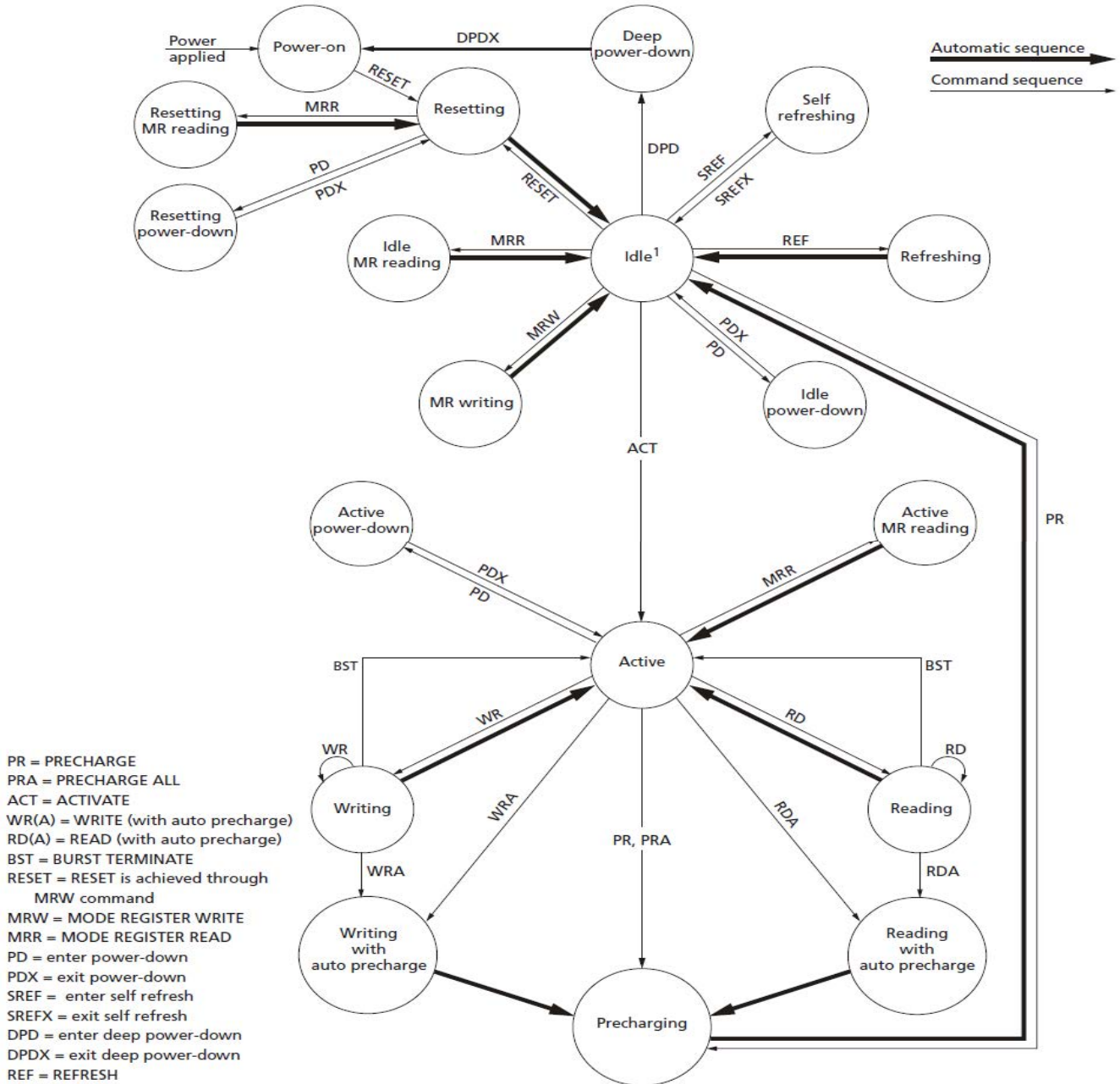
| Speed Grade | Clock Frequency | RL | WL | t _{RCD} (ns) | t _{RP} (ns) |
|-------------|-----------------|----|----|-----------------------|----------------------|
| DDR2L-800 | 400 MHz | 6 | 3 | 18 | 18 |



General Description

The 2Gb Mobile Low-Power DDR2 SDRAM (LPDDR2) is a high-speed CMOS, dynamic random-access memory containing 2,147,483,648 bits. The LPDDR2-S4 device is internally configured as an eight-bank DRAM. Each of the x16's 268,435,456-bit banks is organized as 16,384 rows by 1024 columns by 16 bits. Each of the x32's 268,435,456-bit banks is organized as 16,384 rows by 512 columns by 32 bits.

Simplified Bus Interface State Diagram



Note: 1. All banks are precharged in the idle state.

Address Table

| Parameter | 128Mb X 16 | 64Mb X 32 |
|----------------|--------------------|-------------------|
| Configuration | 16Mb x 8banks x 16 | 8Mb x 8banks x 32 |
| Bank Address | BA0 ~ BA2 | BA0 ~ BA2 |
| Row Address | R0 ~ R13 | R0 ~ R13 |
| Column Address | C0 ~ C9 | C0 ~ C8 |

Note : 1. The least-significant column address CA0 is not transmitted on the CA bus, and is implied to be zero.

Pin Description(X16)

| Symbol | Type | Description |
|------------------------------|-----------|---|
| CK, CK# | Input | Clock : CK and CK# are differential clock inputs. All CA inputs are sampled on both rising and falling edges of CK. CS and CKE inputs are sampled at the rising edge of CK. AC timings are referenced to clock. |
| CKE | Input | Clock enable : CKE HIGH activates and CKE LOW deactivates the internal clock signals, input buffers, and output drivers. Power-saving modes are entered and exited via CKE transitions. CKE is considered part of the command code. CKE is sampled at the rising edge of CK. |
| CS# | Input | Chip select : CS# is considered part of the command code and is sampled at the rising edge of CK. |
| DM0-DM1 | Input | Input data mask : DM is an input mask signal for WRITE data. Although DM balls are input-only, the DM loading is designed to match that of DQ and DQS balls. DM[1:0] is DM for each of the two data bytes, respectively. |
| DQ0 – DQ15 | Input | Data input/output : Bidirectional data bus. |
| DQS0 – DQS1 DQS0# – DQS1# | I/O | Data strobe : The data strobe is bidirectional (used for read and write data) and complementary (DQS and DQS#). It is edge-aligned output with read data and centered input with write data. DQS[1:0]/DQS[1:0]# is DQS for each of the two data bytes, respectively. |
| CA0 – CA9 | Input | Command/address inputs : Provide the command and address inputs according to the command truth table. |
| VDDQ | Supply | DQ Power : Provide isolated power to DQs for improved noise immunity. |
| VSSQ | Supply | DQ Ground : Provide isolated ground to DQs for improved noise immunity. |
| VDDCA | Supply | Command/address power supply : Command/address power supply. |
| VSSCA | Supply | Command/address ground : Isolated on the die for improved noise immunity. |
| VDD1 | Supply | Core power : Supply 1. |
| VDD2 | Supply | Core power : Supply 2. |
| VSS | Supply | Common ground |
| VREFCA, VREFDQ | Supply | Reference voltage : VREFCA is reference for command/address input buffers, VREFDQ is reference for DQ input buffers. |
| ZQ | Reference | External impedance (240 ohm) : This signal is used to calibrate the device output impedance for S4 devices. For S2 devices, ZQ should be tied to VDDCA. |
| DNU | – | Do not use : Must be grounded or left floating. |
| NC | – | No connect : Not internally connected. |
| (NC) | – | No connect : Balls indicated as (NC) are no connects, however, they could be connected together internally. |

Address Table

| Parameter | 128Mb X 16 | 64Mb X 32 |
|----------------|--------------------|-------------------|
| Configuration | 16Mb x 8banks x 16 | 8Mb x 8banks x 32 |
| Bank Address | BA0 ~ BA2 | BA0 ~ BA2 |
| Row Address | R0 ~ R13 | R0 ~ R13 |
| Column Address | C0 ~ C9 | C0 ~ C8 |

Note : 1. The least-significant column address CA0 is not transmitted on the CA bus, and is implied to be zero.

Pin Description(X32)

| Symbol | Type | Description |
|------------------------------|-----------|---|
| CK, CK# | Input | Clock : CK and CK# are differential clock inputs. All CA inputs are sampled on both rising and falling edges of CK. CS and CKE inputs are sampled at the rising edge of CK. AC timings are referenced to clock. |
| CKE | Input | Clock enable : CKE HIGH activates and CKE LOW deactivates the internal clock signals, input buffers, and output drivers. Power-saving modes are entered and exited via CKE transitions. CKE is considered part of the command code. CKE is sampled at the rising edge of CK. |
| CS# | Input | Chip select : CS# is considered part of the command code and is sampled at the rising edge of CK. |
| DM0–DM3 | Input | Input data mask : DM is an input mask signal for WRITE data. Although DM balls are input-only, the DM loading is designed to match that of DQ and DQS balls. DM[3:0] is DM for each of the four data bytes, respectively. |
| DQ0 – DQ31 | Input | Data input/output : Bidirectional data bus. |
| DQS0 – DQS3 DQS0# – DQS3# | I/O | Data strobe : The data strobe is bidirectional (used for read and write data) and complementary (DQS and DQS#). It is edge-aligned output with read data and centered input with write data. DQS[3:0]/DQS[3:0]# is DQS for each of the four data bytes, respectively. |
| CA0 – CA9 | Input | Command/address inputs : Provide the command and address inputs according to the command truth table. |
| VDDQ | Supply | DQ Power : Provide isolated power to DQs for improved noise immunity. |
| VSSQ | Supply | DQ Ground : Provide isolated ground to DQs for improved noise immunity. |
| VDDCA | Supply | Command/address power supply : Command/address power supply. |
| VSSCA | Supply | Command/address ground : Isolated on the die for improved noise immunity. |
| VDD1 | Supply | Core power : Supply 1. |
| VDD2 | Supply | Core power : Supply 2. |
| VSS | Supply | Common ground |
| VREFCA, VREFDQ | Supply | Reference voltage : VREFCA is reference for command/address input buffers, VREFDQ is reference for DQ input buffers. |
| ZQ | Reference | External impedance (240 ohm) : This signal is used to calibrate the device output impedance for S4 devices. For S2 devices, ZQ should be tied to VDDCA. |
| DNU | – | Do not use : Must be grounded or left floating. |
| NC | – | No connect : Not internally connected. |
| (NC) | – | No connect : Balls indicated as (NC) are no connects, however, they could be connected together internally. |

Functional Description

Mobile LPDDR2 is a high-speed SDRAM internally configured as a 8-bank memory device. LPDDR2 devices use a double data rate architecture on the command/address (CA) bus to reduce the number of input pins in the system.

The 10-bit CA bus is used to transmit command, address, and bank information. Each command uses one clock cycle, during which command information is transferred on both the rising and falling edges of the clock.

LPDDR2-S4 devices use a double data rate architecture on the DQ pins to achieve high-speed operation. The double data rate architecture is essentially a $4n$ pre-fetch architecture with an interface designed to transfer two data bits per DQ every clock cycle at the I/O pins. A single read or WRITE access for the LPDDR2-S4 effectively consists of a single $4n$ -bit-wide, one-clock-cycle data transfer at the internal SDRAM core and four corresponding n -bit-wide, one-half-clock-cycle data transfers at the I/O pins.

Read and write accesses are burst oriented; accesses start at a selected location and continue for a programmed number of locations in a programmed sequence.

Accesses begin with the registration of an ACTIVATE command followed by a READ or WRITE command. The address and BA bits registered coincident with the ACTIVATE command are used to select the row and bank to be accessed.

The address bits registered coincident with the READ or WRITE command are used to select the bank and the starting column location for the burst access.

Power-Up

The following sequence must be used to power up the device. Unless specified otherwise, this procedure is mandatory (see Figure1). Power-up and initialization by means other than those specified will result in undefined operation.

1. Voltage Ramp

While applying power (after T_a), CKE must be held LOW ($\leq 0.2 \times V_{DDCA}$), and all other inputs must be between V_{ILMIN} and V_{IHMAX} . The device outputs remain at High-Z while CKE is held LOW. On or before the completion of the voltage ramp (T_b), CKE must be held LOW. DQ, DM, DQS, and DQS# voltage levels must be Between VSSQ and VDDQ during voltage ramp to avoid latch-up. CK, CK#, CS#, and CA input levels must be between VSSCA and VDDCA during voltage ramp to avoid latch up.

The following conditions apply for voltage ramp :

- T_a is the point when any power supply first reaches 300mV.
- Noted conditions apply between T_a and power-down (controlled or uncontrolled).
- T_b is the point at which all supply and reference voltages are within their defined operating ranges.
- Power ramp duration t_{INIT0} ($T_b - T_a$) must not exceed 20ms.
- For supply and reference voltage operating conditions, see the Recommended DC Operating Conditions table.
- The voltage difference between any of VSS, VSSQ, and VSSCA pins must not exceed 100mV.

Voltage Ramp Completion.

After T_a is reached :

- VDD1 must be greater than VDD2 - 200mV
- VDD1 and VDD2 must be greater than VDDCA—200mV
- VDD1 and VDD2 must be greater than VDDQ—200mV
- V_{REF} must always be less than all other supply voltages

Beginning at T_b , CKE must remain LOW for at least $t_{INIT1}=100ns$, after which CKE can be asserted HIGH. The clock must be stable at least $t_{INIT2} = 5 \times t_{CK}$ prior to the first CKE LOW-to-HIGH transition (T_c). CKE, CS#, and CA inputs must observe setup and hold requirements (t_{IS} , t_{IH}) with respect to the first rising clock edge (and to subsequent falling and rising edges). If any MRRs are issued, the clock period must be within the range defined for t_{CKb} (18ns to 100ns). MRWs can be issued at normal clock frequencies as long as all AC timings are met. Some AC parameters (for example, t_{DQCK}) could have relaxed timings (such as t_{DQCKb}) before the system is appropriately configured. While keeping CKE HIGH, NOP commands must be issued for at least $t_{INIT3}=200\mu s$ (T_d).

2. RESET Command

After t_{INIT3} is satisfied, the MRW RESET command must be issued (T_d). An optional PRECHARGE ALL command can be issued prior to the MRW RESET command. Wait at least t_{INIT4} while keeping CKE asserted and issuing NOP commands.

3.MRRs and Device Auto Initialization (DAI) Polling

After t_{INIT4} is satisfied (T_e), only MRR commands and power-down entry/exit commands are supported. After T_e , CKE can go LOW in alignment with power-down entry and exit specifications (see Power-Down (page 53)).

The MRR command can be used to poll the DAI bit, which indicates when device auto initialization is complete; otherwise, the controller must wait a minimum of t_{INIT5} , or until the DAI bit is set, before proceeding. Because the memory output buffers are not properly configured by T_e , some AC parameters must use relaxed timing specifications before the system is appropriately configured.

After the DAI bit (MR0, DAI) is set to zero by the memory device (DAI complete), the device is in the idle state (T_f). DAI status can be determined by issuing the MRR command to MR0. The device sets the DAI bit no later than t_{INIT5} after the RESET command.

The controller must wait at least t_{INIT5} or until the DAI bit is set before proceeding.

4.ZQ Calibration

After t_{INIT5} (T_f), the MRW initialization calibration (ZQ calibration) command can be issued to the memory (MR10).

This command is used to calibrate output impedance over process, voltage, and temperature. In systems where more than one Mobile LPDDR2 device exists on the same bus, the controller must not overlap MRW ZQ calibration commands.

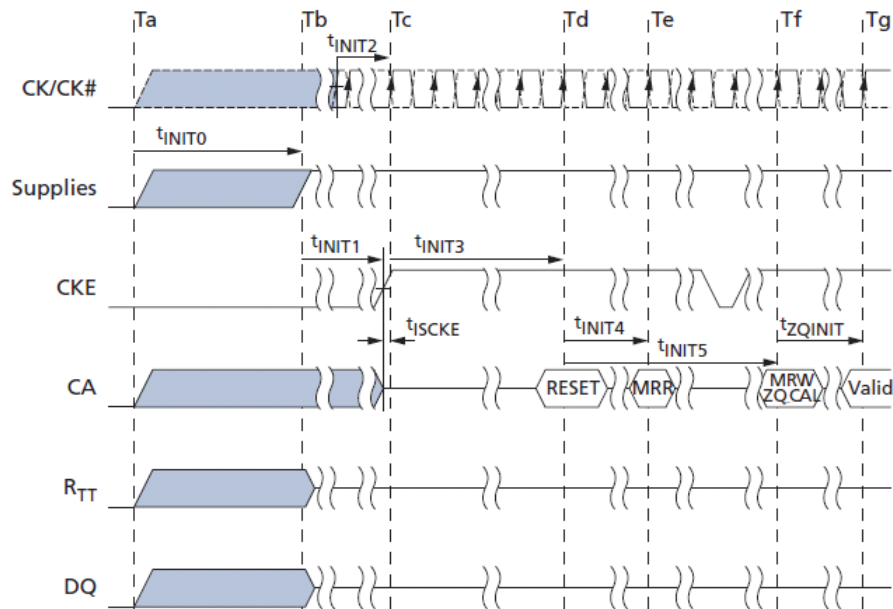
The device is ready for normal operation after t_{ZQINIT} .

5.Normal Operation

After (T_g), MRW commands must be used to properly configure the memory (output buffer drive strength, latencies, etc.).

Specifically, MR1, MR2, and MR3 must be set to configure the memory for the target frequency and memory configuration. After the initialization sequence is complete, the device is ready for any valid command. After T_g , the clock frequency can be changed using the procedure described in Input Clock Frequency Changes and Clock Stop with CKE HIGH (page 62).

Figure 1 : Voltage Ramp and Initialization Sequence



Note : 1. High-Z on the CA bus indicates valid NOP.

Table1 : Initialization Timing Parameters

| Parameter | Value | | Unit | Comment |
|---------------------|-------|-----|-----------------|---|
| | Min | Max | | |
| t _{INIT0} | - | 20 | ms | Maximum voltage ramp time |
| t _{INIT1} | 100 | - | ns | Minimum CKE LOW time after completion of voltage ramp |
| t _{INIT2} | 5 | - | t _{CK} | Minimum stable clock before first CKE HIGH |
| t _{INIT3} | 200 | - | μs | Minimum idle time after first CKE assertion |
| t _{INIT4} | 1 | - | μs | Minimum idle time after RESET command |
| t _{INIT5} | - | 10 | μs | Maximum duration of device auto initialization |
| t _{ZQINIT} | 1 | - | μs | ZQ initial calibration (S4 devices only) |
| t _{CKb} | 18 | - | ns | Clock cycle time during boot |

Initialization After RESET (Without Voltage Ramp)

If the RESET command is issued before or after the power-up initialization sequence, the reinitialization procedure must begin at Td.

Power-Off

While powering off, CKE must be held LOW ($\leq 0.2 \times VDDCA$); all other inputs must be between V_{ILMIN} and V_{IHMAX} .

The device outputs remain at High-Z while CKE is held LOW. DQ, DM, DQS, and DQS# voltage levels must be between VSSQ and VDDQ during the power-off sequence to avoid latch-up. CK, CK#, CS#, and CA input levels must be between VSSCA and VDDCA during the power-off sequence to avoid latch-up.

Tx is the point where any power supply drops below the minimum value specified in the Recommended DC Operating Conditions table. Tz is the point where all power supplies are below 300mV. After Tz, the device is powered off.

Required Power Supply Conditions Between Tx and Tz:

- VDD1 must be greater than VDD2 - 200mV.
- VDD1 must be greater than VDDCA - 200mV.
- VDD1 must be greater than VDDQ - 200mV.
- VREF must always be less than all other supply voltages.

The voltage difference between VSS, VSSQ, and VSSCA must not exceed 100mV.

For supply and reference voltage operating conditions, see Recommended DC Operating Conditions table.

Uncontrolled Power-Off

When an uncontrolled power-off occurs, the following conditions must be met:

- At Tx, when the power supply drops below the minimum values specified in the Recommended DC Operating Conditions table, all power supplies must be turned off and all power-supply current capacity must be at zero, except for any static charge remaining in the system.
- After Tz (the point at which all power supplies first reach 300mV), the device must power off.

The time between Tx and Tz must not exceed tPOFF. During this period, the relative voltage between power supplies is uncontrolled.

VDD1 and VDD2 must decrease with a slope lower than $0.5V/\mu s$ between Tx and Tz.

An uncontrolled power-off sequence can occur a maximum of 400 times over the life of the device.

Table2 : Power-Off Timing

| Parameter | Symbol | Min | Max | Unit |
|-----------------------------|--------|-----|-----|------|
| Maximum power-off ramp time | tPOFF | - | 2 | Sec |

Mode Register Definition

LPDDR2 devices contain a set of mode registers used for programming device operating parameters, reading device information and status, and for initiating special operations such as DQ calibration, ZQ calibration, and device reset.

Mode Register Assignments and Definitions

The MRR command is used to read from a register. The MRW command is used to write to a register. An “R” in the access column of the mode register assignment table indicates read-only; a “W” indicates write-only; “R/W” indicates read or WRITE capable or enabled.

Table3 : Mode Register Assignments

| MR # | MA [7:0] | Function | Access | OP7 | OP6 | OP5 | OP4 | OP3 | OP2 | OP1 | OP0 | Link | |
|---------|----------|--------------------------|--------|---------------------------|---------|-----|-----------|--------------|-----|-----|-----------|-------------|-------------|
| 0 | 00h | Device info | R | RFU | | | RZQI | DNVI | DI | DAI | | go to MR0 | |
| 1 | 01h | Device feature 1 | W | <i>nWR (for AP)</i> | | | WC | BT | BL | | | go to MR1 | |
| 2 | 02h | Device feature 2 | W | RFU | | | RL and WL | | | | go to MR2 | | |
| 3 | 03h | I/O config-1 | W | RFU | | | DS | | | | go to MR3 | | |
| 4 | 04h | SDRAM refresh rate | R | TUF | RFU | | | Refresh rate | | | go to MR4 | | |
| 5 | 05h | Basic config-1 | R | LPDDR2 Manufacturer ID | | | | | | | | go to MR5 | |
| 6 | 06h | Basic config-2 | R | Revision ID1 | | | | | | | | go to MR6 | |
| 7 | 07h | Basic config-3 | R | Revision ID2 | | | | | | | | go to MR7 | |
| 8 | 08h | Basic config-4 | R | I/O width | Density | | | Type | | | go to MR8 | | |
| 9 | 09h | Test mode | W | Vendor-specific test mode | | | | | | | | go to MR9 | |
| 10 | 0Ah | I/O calibration | W | Calibration code | | | | | | | | go to MR10 | |
| 11-15 | 0Bh-0Fh | Reserved | - | RFU | | | | | | | | go to MR11 | |
| 16 | 10h | PASR_Bank | W | Bank mask | | | | | | | | go to MR16 | |
| 17 | 11h | PASR_Seg | W | Segment mask | | | | | | | | go to MR17 | |
| 18-19 | 12h-13h | Reserved | - | RFU | | | | | | | | go to MR18 | |
| 20-31 | 14h-1Fh | Reserved for NVM | | | | | | | | | | go to MR30 | |
| 32 | 20h | DQ calibration pattern A | R | See Table 28 | | | | | | | | go to MR32 | |
| 33-39 | 21h-27h | Do not use | | | | | | | | | | go to MR33 | |
| 40 | 28h | DQ calibration pattern B | R | See Table 28 | | | | | | | | go to MR40 | |
| 41-47 | 29h-2Fh | Do not use | | | | | | | | | | go to MR41 | |
| 48-62 | 30h-3Eh | Reserved | - | RFU | | | | | | | | go to MR48 | |
| 63 | 3Fh | RESET | W | X | | | | | | | | go to MR63 | |
| 64-126 | 40h-7Eh | Reserved | - | RFU | | | | | | | | go to MR64 | |
| 127 | 7Fh | Do not use | | | | | | | | | | go to MR127 | |
| 128-190 | 80h-BEh | Reserved for vendor use | | | RVU | | | | | | | | go to MR128 |
| 191 | BFh | Do not use | | | | | | | | | | go to MR191 | |
| 192-254 | C0h-FEh | Reserved for vendor use | | | RVU | | | | | | | | go to MR192 |
| 255 | FFh | Do not use | | | | | | | | | | go to MR255 | |

- Notes :
1. RFU bits must be set to 0 during MRW.
 2. RFU bits must be read as 0 during MRR.
 3. For READs to a write-only or RFU register, DQS will be toggled and undefined data is returned.
 4. RFU mode registers must not be written.
 5. WRITEs to read-only registers must have no impact on the functionality of the device.

Table4 : MR0 Device information

| OP7 | OP6 | OP5 | OP4 | OP3 | OP2 | OP1 | OP0 |
|--|-----|-----------|---------|---|------|-----|-----|
| RFU | | | RZQI | | DNVI | DI | DAI |
| DAI (Device Auto-Initialization Status) | | Read-only | OP0 | 0b : DAI complete 1b : DAI still in progress | | | |
| DI (Device Information) | | Read-only | OP1 | 0b : SDRAM 1b : NVM | | | |
| DNVI (Data Not Valid Information) | | Read-only | OP2 | LPDDR2 SDRAM will not implement DNV functionality | | | |
| RZQI(Built in Self Test for RZQ Information) | | Read-only | OP[4:3] | 00b : RZQ self test not executed 01b : ZQ-pin may connect to VDDCA or float 10b : ZQ-pin may short to GND 11b : ZQ-pin self test completed, no error condition detected (ZQ-pin may not connect to VDDCA or float nor short to GND) | | | |

Notes : 1. If RZQI is supported, it will be set upon completion of the MRW ZQ initialization calibration.

- If ZQ is connected to VDDCA to set default calibration, OP[4:3] must be set to 01. If ZQ is not connected to VDDCA, either OP[4:3]=01 or OP[4:3]=10 could indicate a ZQ-pin assembly error. It is recommended that the assembly error be corrected.
- In the case of a possible assembly error(either OP[4:3]=01 or OP[4:3]=10, as defined above), the device will default to factory trim settings for RON and will ignore ZQ calibration commands. In either case, the system might not function as Intended.
- If a ZQ self test returns a value of 11b, this indicates that the device has detected a resistor connection to the ZQ pin. Note that this result cannot be used to validate the ZQ resistor value, nor does it indicate that the ZQ resistor tolerance meets the specified limits (240 ohms \pm 1%).

Table5 : MR1 Device Feature 1 (MA[7:0] = 01h)

| OP7 | OP6 | OP5 | OP4 | OP3 | OP2 | OP1 | OP0 |
|---------------------|--------------|---------|-----|---|-----|-----|-----|
| <i>nWR (for AP)</i> | | | WC | BT | BL | | |
| BL | Write - only | OP[2:0] | | 010b : BL4 (default) 011b : BL8 100b : BL16 All others : reserved | | | |
| BT | Write - only | OP3 | | 0b : Sequential (default) 1b : Interleaved | | | |
| WC | Write – only | OP4 | | 0b : Wrap (default) 1b : No wrap (allowed for SDRAM BL4 only) | | | |
| <i>nWR</i> | Write – only | OP[7:5] | | 001b : nWR = 3 (default) 010b : nWR = 4 011b : nWR = 5 100b : nWR = 6 101b : nWR = 7 110b : nWR = 8 All others : reserved | | | |

Note : 1. Programmed value in nWR register is the number of clock cycles which determines when to start internal precharge operation for a write burst with AP enabled. It is determined by $RU(tWR / tCK)$.

Table6 : Burst Sequence by Burst Length(BL), Burst Type(BT), and Wrap Control(WC)

| BL | BT | C3 | C2 | C1 | C0 | WC | Burst Cycle Number and Burst Address Sequence | | | | | | | | | | | | | | | | | | | | |
|-----|-----|-----|----|----|----|---------|---|-------------------------|-----|-----|---|---|---|---|---|----|----|----|----|----|----|----|---|---|--|--|--|
| | | | | | | | 1 | 2 | 3 | 4 | 5 | 6 | 7 | 8 | 9 | 10 | 11 | 12 | 13 | 14 | 15 | 46 | | | | | |
| 4 | Any | X | X | 0b | 0b | Wrap | 0 | 1 | 2 | 3 | | | | | | | | | | | | | | | | | |
| | | X | X | 1b | 0b | | 2 | 3 | 0 | 1 | | | | | | | | | | | | | | | | | |
| | Any | X | X | X | 0b | No Wrap | y | y+1 | y+2 | y+3 | | | | | | | | | | | | | | | | | |
| 8 | Seq | X | 0b | 0b | 0b | Wrap | 0 | 1 | 2 | 3 | 4 | 5 | 6 | 7 | | | | | | | | | | | | | |
| | | X | 0b | 1b | 0b | | 2 | 3 | 4 | 5 | 6 | 7 | 0 | 1 | | | | | | | | | | | | | |
| | | X | 1b | 0b | 0b | | 4 | 5 | 6 | 7 | 0 | 1 | 2 | 3 | | | | | | | | | | | | | |
| | | X | 1b | 1b | 0b | | 6 | 7 | 0 | 1 | 2 | 3 | 4 | 5 | | | | | | | | | | | | | |
| | Int | X | 0b | 0b | 0b | | 0 | 1 | 2 | 3 | 4 | 5 | 6 | 7 | | | | | | | | | | | | | |
| | | X | 0b | 1b | 0b | | 2 | 3 | 0 | 1 | 6 | 7 | 4 | 5 | | | | | | | | | | | | | |
| | | X | 1b | 0b | 0b | | 4 | 5 | 6 | 7 | 0 | 1 | 2 | 3 | | | | | | | | | | | | | |
| | | X | 1b | 1b | 0b | | 6 | 7 | 4 | 5 | 2 | 3 | 0 | 1 | | | | | | | | | | | | | |
| | Any | X | X | X | 0b | | No Wrap | illegal (not supported) | | | | | | | | | | | | | | | | | | | |
| | 16 | Seq | 0b | 0b | 0b | | 0b | Wrap | 0 | 1 | 2 | 3 | 4 | 5 | 6 | 7 | 8 | 9 | A | B | C | D | E | F | | | |
| 0b | | | 0b | 1b | 0b | 2 | 3 | | 4 | 5 | 6 | 7 | 8 | 9 | A | B | C | D | E | F | 0 | 1 | | | | | |
| 0b | | | 1b | 0b | 0b | 4 | 5 | | 6 | 7 | 8 | 9 | A | B | C | D | E | F | 0 | 1 | 2 | 3 | | | | | |
| 0b | | | 1b | 1b | 0b | 6 | 7 | | 8 | 9 | A | B | C | D | E | F | 0 | 1 | 2 | 3 | 4 | 5 | | | | | |
| 1b | | | 0b | 0b | 0b | 8 | 9 | | A | B | C | D | E | F | 0 | 1 | 2 | 3 | 4 | 5 | 6 | 7 | | | | | |
| 1b | | | 0b | 1b | 0b | A | B | | C | D | E | F | 0 | 1 | 2 | 3 | 4 | 5 | 6 | 7 | 8 | 9 | | | | | |
| 1b | | | 1b | 0b | 0b | C | D | | E | F | 0 | 1 | 2 | 3 | 4 | 5 | 6 | 7 | 8 | 9 | A | B | | | | | |
| 1b | | | 1b | 1b | 0b | E | F | | 0 | 1 | 2 | 3 | 4 | 5 | 6 | 7 | 8 | 9 | A | B | C | D | | | | | |
| Int | | X | X | X | 0b | No Wrap | illegal (not supported) | | | | | | | | | | | | | | | | | | | | |
| Any | | X | X | X | 0b | No Wrap | illegal (not supported) | | | | | | | | | | | | | | | | | | | | |

Notes : 1. C0 input is not present on CA bus. It is implied zero.

2. For BL = 4, the burst address represents C[1:0].

3. For BL = 8, the burst address represents C[2:0].

4. For BL = 16, the burst address represents C[3:0].

5. For no-wrap, BL4, the burst must not cross the page boundary or the sub-page boundary.

The variable y can start at any address with C0 equal to 0, but must not start at any address shown in the following table.

Table7 : No – Wrap Restrictions

| Bus Width | 2Gb |
|-----------|-------------------------------|
| | Not across full page boundary |
| X 16 | 3FE, 3FF, 000, 001 |
| X 32 | 1FE, 1FF, 000, 001 |
| | Not across sub page boundary |
| X 16 | 1FE, 1FF, 200, 201 |
| X 32 | None |

Note : 1. No-wrap BL = 4 data orders shown are prohibited.

Table8 : MR2 Device Feature 2 (MA[7:0] = 02h)

| OP7 | OP6 | OP5 | OP4 | OP3 | OP2 | OP1 | OP0 |
|-----------|--------------|----------|-------------------------------|-----------|-----|-----|-----|
| RFU | | | | RL and WL | | | |
| RL and WL | Write - only | OP [3:0] | 0001b : RL=3 / WL=1 (default) | | | | |
| | | | 0010b : RL=4 / WL=2 | | | | |
| | | | 0011b : RL=5 / WL=2 | | | | |
| | | | 0100b : RL=6 / WL=3 | | | | |
| | | | 0101b : RL=7 / WL=4 | | | | |
| | | | 0110b : RL=8 / WL=4 | | | | |
| | | | All others : reserved | | | | |

Table9 : MR3 I/O Configuration 1 (MA [7:0] =03h)

| OP7 | OP6 | OP5 | OP4 | OP3 | OP2 | OP1 | OP0 |
|-----|--------------|----------|---------------------------------------|-----|-----|-----|-----|
| RFU | | | | DS | | | |
| DS | Write - only | OP [3:0] | 0000b : reserved | | | | |
| | | | 0001b : 34.3 ohm typical | | | | |
| | | | 0010b : 40 ohm typical | | | | |
| | | | 0011b : 48 ohm typical | | | | |
| | | | 0100b : 60 ohm typical | | | | |
| | | | 0101b : reserved for 68.6 ohm typical | | | | |
| | | | 0110b : 80 ohm typical | | | | |
| | | | 0111b : 120 ohm typical | | | | |
| | | | All others : reserved | | | | |

Table10 : MR4 Device Temperature (MA [7:0] =04h)

| OP7 | OP6 | OP5 | OP4 | OP3 | OP2 | OP1 | OP0 |
|--------------------|-------------|----------|--|-----|--------------------|-----|-----|
| TUF | RFU | | | | SDRAM Refresh Rate | | |
| SDRAM Refresh rate | Read - only | OP [2:0] | 000b : SDRAM Low temperature operating limit exceeded. | | | | |
| | | | 001b : 4x tREF, 4x tREFIpb, 4x tREFW. | | | | |
| | | | 010b : 2x tREF, 2x tREFIpb, 2x tREFW. | | | | |
| | | | 011b : 1x tREF, 1x tREFIpb, 1x tREFW (<= 85°C). | | | | |
| | | | 100b : Reserved. | | | | |

| | | | |
|-------------------------------|--------------|----------|---|
| SDRAM Refresh rate | Read - only | OP [2:0] | 101b : 0.25x tREF, 0.25x tREFIpb, 0.25x tREFW, do not de-rate SDRAM AC timing . |
| | | | 110b : 0.25x tREF, 0.25x tREFIpb, 0.25x tREFW, de-rate SDRAM AC timing . |
| | | | 111b : SDRAM High temperature operating limit exceeded. |
| Temperature Update Flag (TUF) | Read - only | OP7 | 0b : OP [2:0] value has not changed since last read of MR4. |
| | | | 1b : OP [2:0] value has changed since last read of MR4. |
| RL and WL | Write – only | OP [3:0] | 0001b : RL=3 / WL=1 (default) |
| | | | 0010b : RL=4 / WL=2 |
| | | | 0011b : RL=5 / WL=2 |
| | | | 0100b : RL=6 / WL=3 |
| | | | 0101b : RL=7 / WL=4 |
| | | | 0110b : RL=8 / WL=4 |
| | | | All others : reserved |

Notes:

1. A Mode Register Read from MR4 will reset OP7 to '0'.
2. OP7 is reset to '0' at power-up
3. If OP2 equals '1', the device temperature is greater than 85°C
4. OP7 is set to '1' if OP2-OP0 has changed at any time since the last read of MR4.
5. LPDDR2 might not operate properly when OP[2:0] = 000b or 111b.
6. LPDDR2 devices must be de-rated by adding 1.875ns to the following core timing parameters ; tRCD, tRC, tRAS, tRP, and tRRD. tDQSCK shall be de-rated according to the tDQSCK de-rating value in AC timing table. Prevailing clock frequency spec and related setup and hold timings shall remain unchanged.
7. The recommended frequency for reading MR4 is provided in Temperature Sensor.

Table11 : MR5 Basic Configuration 1 (MA [7:0] = 05h)

| OP7 | OP6 | OP5 | OP4 | OP3 | OP2 | OP1 | OP0 |
|------------------------|-----|-----------|-----|---------|-----|--|-----|
| LPDDR2 Manufacturer ID | | | | | | | |
| LPDDR2 Manufacturer ID | | Read-only | | OP[7:0] | | 1111 1000b : Alliance (F8h) All others : Reserved | |

Table12 : MR6 Basic Configuration 2 (MA [7:0] = 06h)

| OP7 | OP6 | OP5 | OP4 | OP3 | OP2 | OP1 | OP0 |
|--------------|-----|-----------|-----|---------|-----|------------------------|-----|
| Revision ID1 | | | | | | | |
| Revision ID1 | | Read-only | | OP[7:0] | | 0000 0000b : A-version | |

Table13 : MR7 Basic Configuration 3 (MA [7:0] = 07h)

| OP7 | OP6 | OP5 | OP4 | OP3 | OP2 | OP1 | OP0 |
|--------------|-----|-----------|-----|---------|-----|------------------------|-----|
| Revision ID2 | | | | | | | |
| Revision ID2 | | Read-only | | OP[7:0] | | 0000 0000b : A-version | |

Table14 : MR8 Basic Configuration 4 (MA [7:0] = 08H)

| OP7 | OP6 | OP5 | OP4 | OP3 | OP2 | OP1 | OP0 |
|-----------|-----|-------------|-----|----------|-----|----------------|-----|
| I/O width | | Density | | | | Type | |
| Type | | Read – only | | OP [1:0] | | 00b : S4 SDRAM | |
| Density | | Read – only | | OP [5:2] | | 0100b : 1Gb | |
| | | | | | | 0101b : 2Gb | |
| I/O width | | Read – only | | OP [7:6] | | 00b : x32 | |
| | | | | | | 01b : x16 | |

Table15 : MR9 Test Mode (MA [7:0] = 09H)

| OP7 | OP6 | OP5 | OP4 | OP3 | OP2 | OP1 | OP0 |
|-----------------------------|-----|-----|-----|-----|-----|-----|-----|
| Vendor – specific Test Mode | | | | | | | |

Table16 : MR10 Calibration (MA [7:0] = 0AH)

| OP7 | OP6 | OP5 | OP4 | OP3 | OP2 | OP1 | OP0 |
|------------------|-----|--------------|-----|----------|-----|--|-----|
| Calibration Code | | | | | | | |
| Calibration Code | | Write - only | | OP [7:0] | | 0xFF : Calibration command after initialization. | |
| | | | | | | 0xAB : Long calibration | |
| | | | | | | 0x56 : Short calibration | |
| | | | | | | 0xC3 : ZQ Reset | |
| | | | | | | All others : Reserved | |

Notes : 1. Host processor must not write MR10 with reserved values.

2. The device ignores calibration commands when a reserved value is written into MR10.

3. See AC timing table for the calibration latency.

4. If ZQ is connected to VSSCA through RZQ, either the ZQ calibration function (see MRW ZQ Calibration Commands (page 51)) or default calibration (through the ZQRESET command) is supported.

If ZQ is connected to VBDCA, the device operates with default calibration and ZQ calibration commands are ignored.

In both cases, the ZQ connection must not change after power is supplied to the device.

Table17 : MR[11-15] Reserved (MA [7:0] = 0BH – 0FH)

| OP7 | OP6 | OP5 | OP4 | OP3 | OP2 | OP1 | OP0 |
|----------|-----|-----|-----|-----|-----|-----|-----|
| Reserved | | | | | | | |

Table18 : MR16 PASR Bank Mask (MA [7:0] = 10H)

| OP7 | OP6 | OP5 | OP4 | OP3 | OP2 | OP1 | OP0 |
|------------------------------|-----|--------------|-----|----------|-----|--|-----|
| Bank Mask (4-bank or 8-bank) | | | | | | | |
| Bank [7:0] Mask | | Write - only | | OP [7:0] | | 0b : Refresh enable to the bank = unmasked (default) | |
| | | | | | | 1b : Refresh blocked = masked | |

Table19 : MR17 PASR Segment Mask (MA [7:0] = 11H)

| OP7 | OP6 | OP5 | OP4 | OP3 | OP2 | OP1 | OP0 |
|--------------------|-----|--------------|-----|--------------|-----|-----|---|
| Segment Mask | | | | | | | |
| Segment | | Write – only | | OP [7:0] | | | 0b : Refresh enable to the Segment = unmasked (default) |
| | | | | | | | 1b : Refresh blocked = masked |
| Segment [7:0] Mask | | OP | | Segment Mask | | | R [13:11] |
| 0 | | 0 | | XXXXXXXX1 | | | 000b |
| 1 | | 1 | | XXXXXXXX1X | | | 001b |
| 2 | | 2 | | XXXXX1XX | | | 010b |
| 3 | | 3 | | XXXX1XXX | | | 011b |
| 4 | | 4 | | XXX1XXXX | | | 100b |
| 5 | | 5 | | XX1XXXXX | | | 101b |
| 6 | | 6 | | X1XXXXXX | | | 110b |
| 7 | | 7 | | 1XXXXXXX | | | 111b |

Table20 : Reserved Mode Register

| Mode Register | MA | 0 | Restriction | OP7 | OP6 | OP5 | OP4 | OP3 | OP2 | OP1 | OP0 |
|---------------|---------|---------|------------------|----------|-----|-----|-----|-----|-----|-----|-----|
| MR[18:19] | MA[7:0] | 12h-13h | RFU | Reserved | | | | | | | |
| MR[20:31] | | 14h-1Fh | NVM ¹ | | | | | | | | |
| MR[33:39] | | 21h-27h | DNU ¹ | | | | | | | | |
| MR[41:47] | | 29h-2Fh | | | | | | | | | |
| MR[48:62] | | 30h-3Eh | RFU | | | | | | | | |
| MR[64:126] | | 40h-7Eh | RFU | | | | | | | | |
| MR[127] | | 7Fh | DNU | | | | | | | | |
| MR[128:190] | | 80h-BEh | RVU ¹ | | | | | | | | |
| MR[191] | | BFh | DNU | | | | | | | | |
| MR[192:254] | | C0h-FEh | RVU | | | | | | | | |
| MR[255] | | FFh | DNU | | | | | | | | |

Note : 1. NVM = nonvolatile memory use only; DNU = Do not use; RVU = Reserved for vendor use.

Table21 : MR63 Reset (MA [7:0] = 3FH) – MRW Only

| OP7 | OP6 | OP5 | OP4 | OP3 | OP2 | OP1 | OP0 |
|-----|-----|-----|-----|-----|-----|-----|-----|
| X | | | | | | | |

Note : For additional information on MRW RESET see MODE REGISTER WRITE Command (page 50).

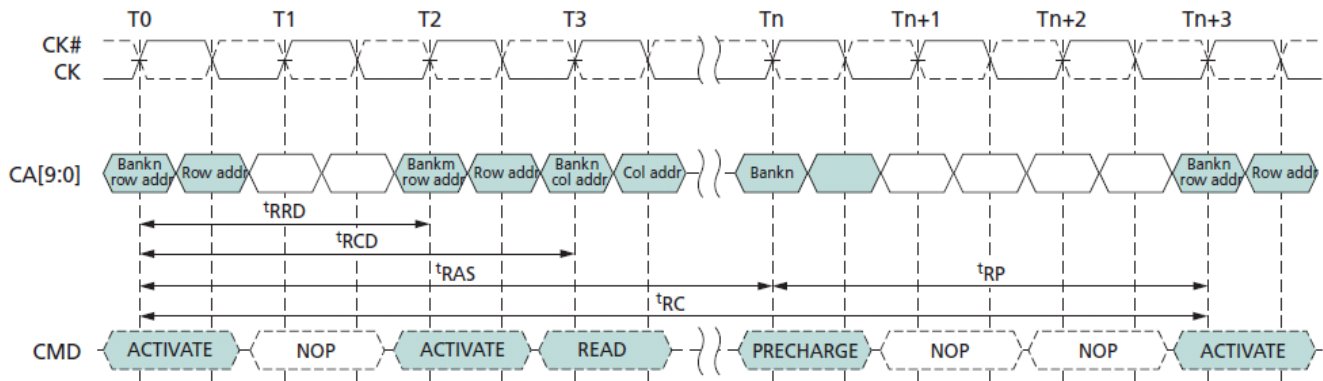
ACTIVATE Command

The ACTIVATE command is issued by holding CS# LOW, CA0 LOW, and CA1 HIGH at the rising edge of the clock.

The bank addresses BA[2:0] are used to select the desired bank. Row addresses are used to determine which row to activate in the selected bank. The ACTIVATE command must be applied before any READ or WRITE operation can be executed. The device can accept a READ or WRITE command at tRCD after the ACTIVATE command is issued. After a bank has been activated, it must be precharged before another ACTIVATE command can be applied to the same bank. The bank active and precharge times are defined as tRAS and tRP, respectively.

The minimum time interval between successive ACTIVATE commands to the same bank is determined by the RAS cycle time of the device (tRC). The minimum time interval between ACTIVATE commands to different banks is tRRD.

Figure 2: ACTIVATE Command



Notes : 1. tRCD = 3, tRP = 3, tRRD = 2.

2. A PRECHARGE ALL command uses tRPab timing, and a single-bank PRECHARGE command uses tRPpb timing.

In this figure, tRP is used to denote either an all-bank PRECHARGE or a single-bank PRECHARGE.

8-Bank Device Operation

Two rules regarding 8-bank device operation must be observed.

One rule restricts the number of sequential ACTIVATE commands that can be issued; the second provides additional RAS precharge time for a PRECHARGE ALL command.

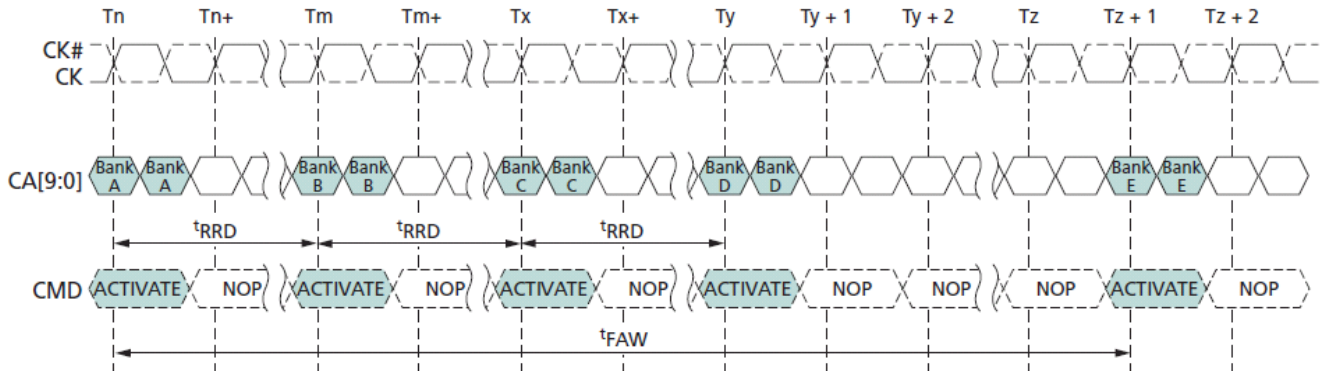
The 8-Bank Device Sequential Bank Activation Restriction :

No more than four banks can be activated (or refreshed, in the case of REFpb) in a rolling tFAW window. To convert to clocks, divide tFAW[ns] by tCK[ns], and round up to the next integer value.

For example, if $RU(tFAW/tCK)$ is 10 clocks, and an ACTIVATE command is issued in clock n , no more than three further ACTIVATE commands can be issued at or between clock $n + 1$ and $n + 9$. REFpb also counts as bank activation for purposes of tFAW.

The 8-Bank Device PRECHARGE ALL Provision:

tRP for a PRECHARGE ALL command must equal tRPab, which is greater than tRPpb.

Figure 3 : tFAW Timing (8-Bank Devices)


Note : 1. Exclusively for 8-bank devices.

Read and Write Access Modes

After a bank is activated, a READ or WRITE command can be issued with CS# LOW, CA0 HIGH, and CA1 LOW at the rising edge of the clock. CA2 must also be defined at this time to determine whether the access cycle is a READ operation (CA2 HIGH) or a WRITE operation (CA2 LOW). A single READ or WRITE command initiates a burst READ or burst WRITE operation on successive clock cycles. A new burst access must not interrupt the previous 4-bit burst operation when BL = 4. When BL = 8 or BL = 16, READs can be interrupted by READs and WRITEs can be interrupted by WRITEs, provided that the interrupt occurs on a 4-bit boundary and that tCCD is met.

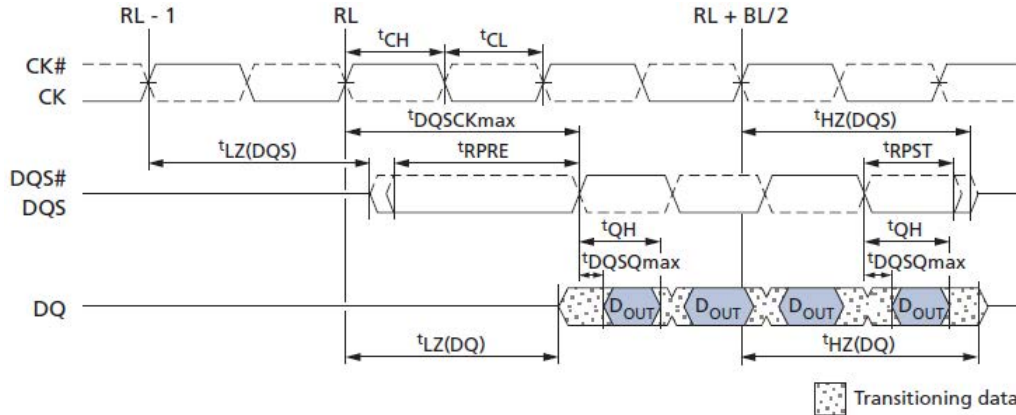
Burst READ Command

The burst READ command is initiated with CS# LOW, CA0 HIGH, CA1 LOW, and CA2 HIGH at the rising edge of the clock. The command address bus inputs, CA5r–CA6r and CA1f–CA9f, determine the starting column address for the burst. The read latency (RL) is defined from the rising edge of the clock on which the READ command is issued to the rising edge of the clock from which the tDQSCK delay is measured. The first valid data is available $RL \times tCK + tDQSCK + tDQSQ$ after the rising edge of the clock when the READ command is issued.

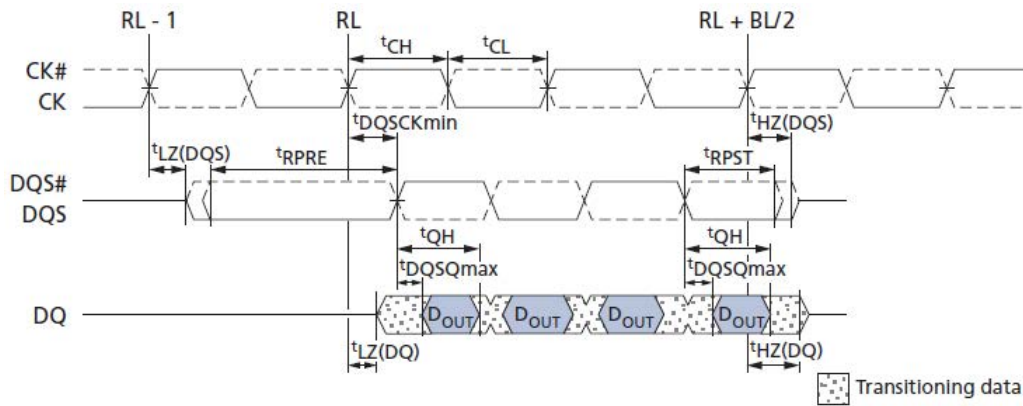
The data strobe output is driven LOW tRPRE before the first valid rising strobe edge.

The first bit of the burst is synchronized with the first rising edge of the data strobe. Each subsequent data-out appears on each DQ pin, edge-aligned with the data strobe. The RL is programmed in the mode registers.

Pin input timings for the data strobe are measured relative to the crosspoint of DQS and its complement, DQS#.

Figure 4 : READ Output Timing – tDQSK (MAX)


- Notes : 1. tDQSK can span multiple clock periods.
2 An effective burst length of 4 is shown.

Figure 5 : READ Output Timing – tDQSK (MIN)


- Note : 1. An effective burst length of 4 is shown.

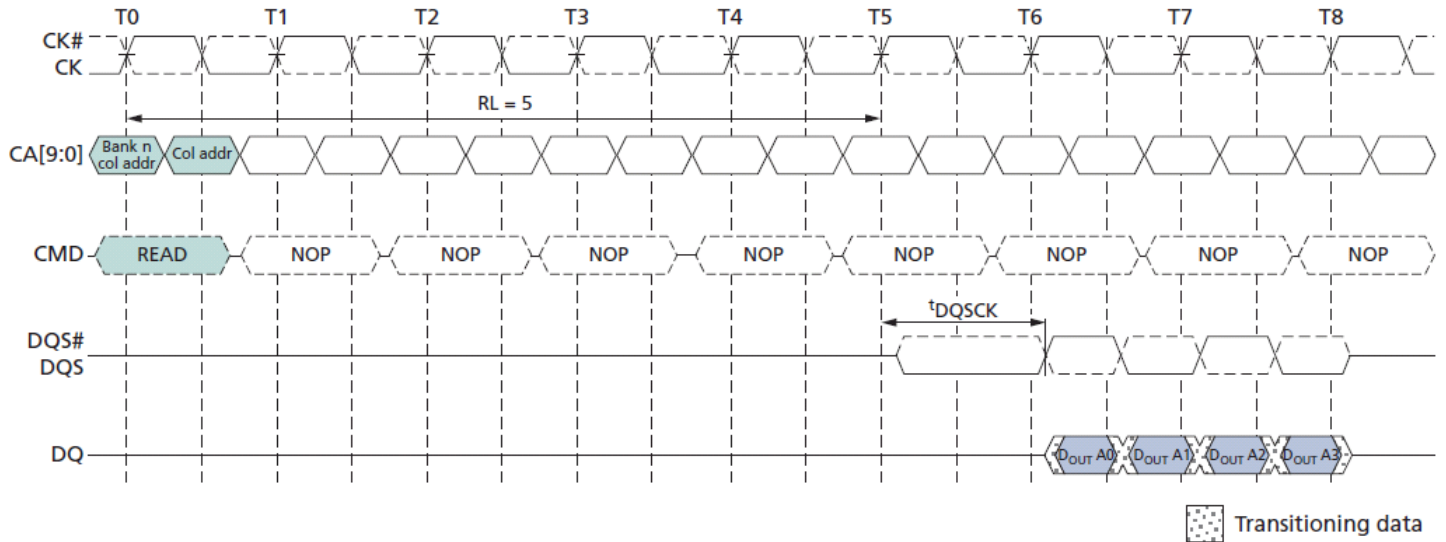
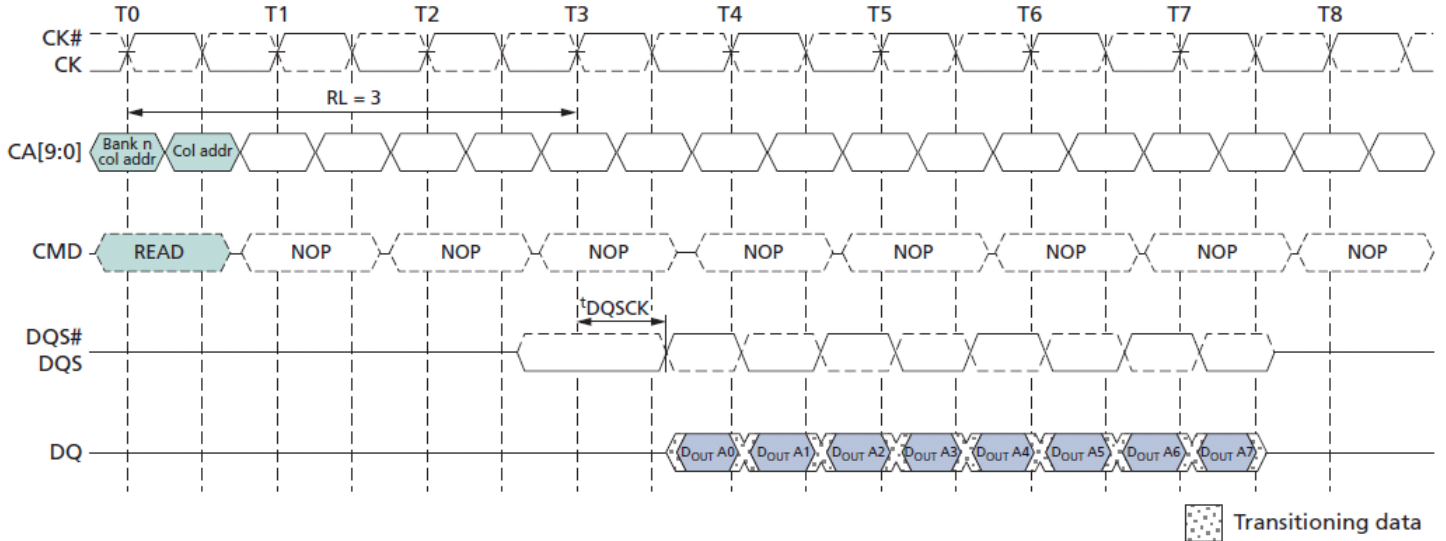
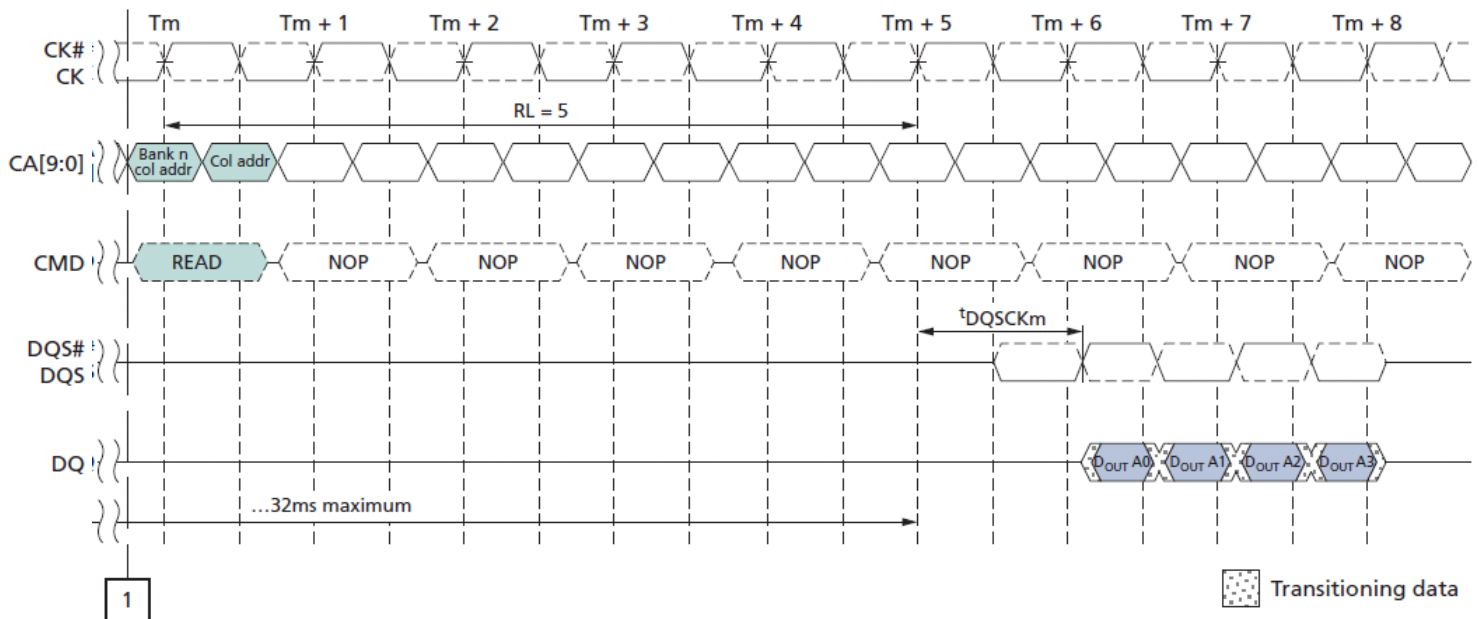
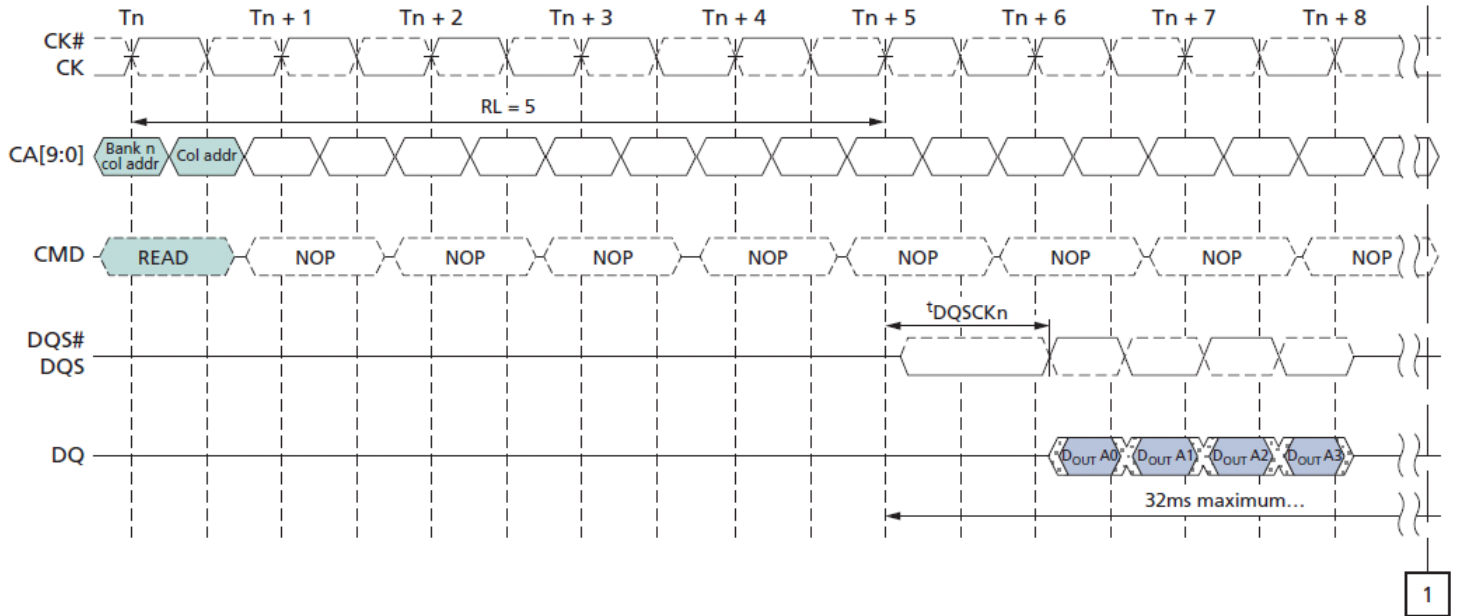
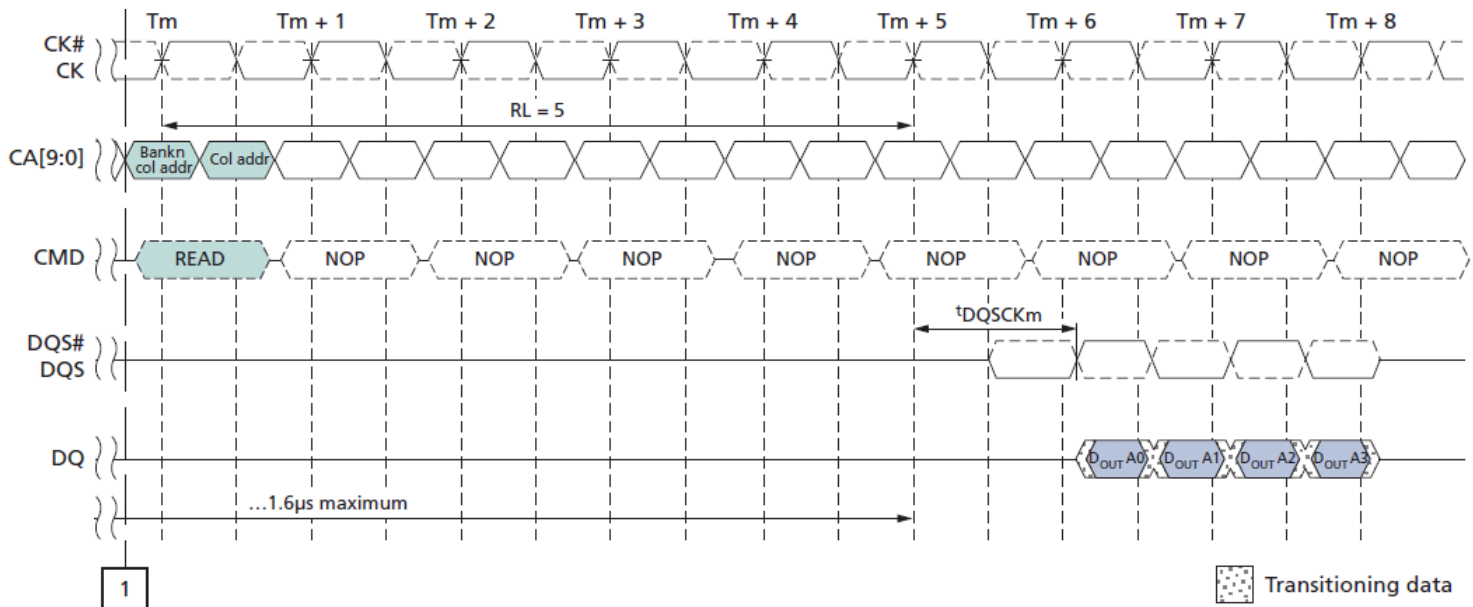
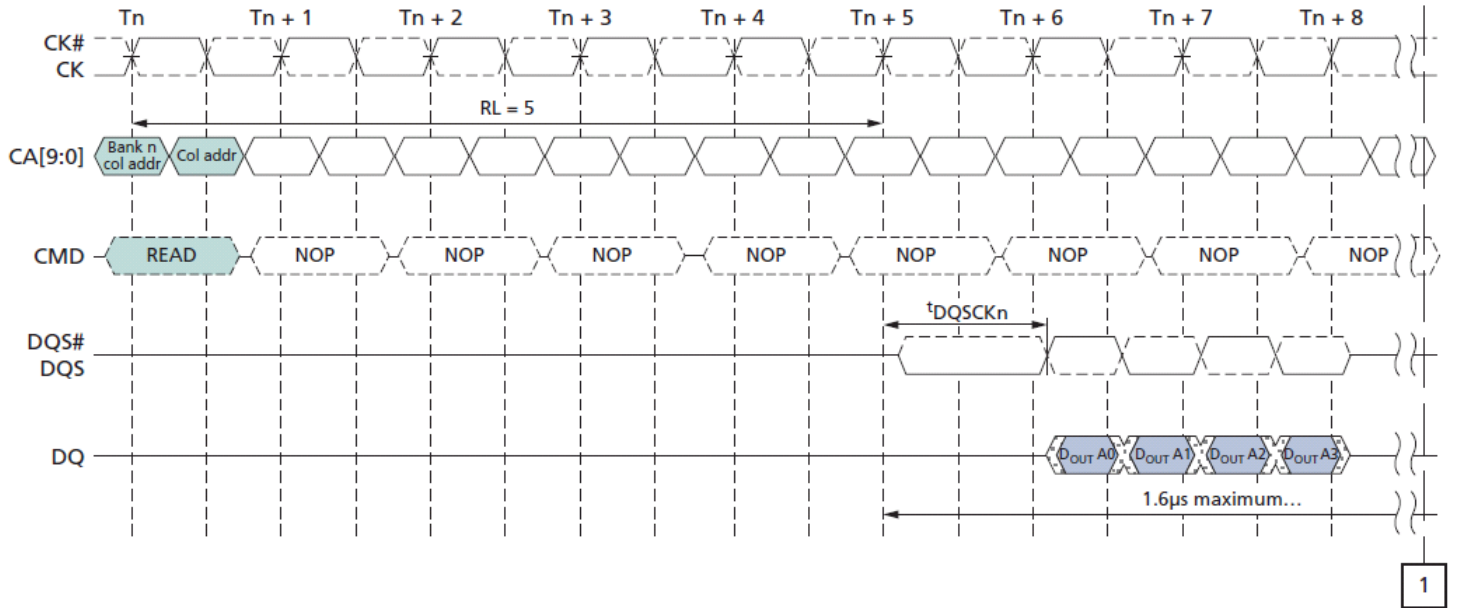
Figure 6 : Burst READ – RL = 5, BL = 4, $t_{DQSCK} > t_{CK}$

Figure 7 : Burst READ – RL = 3, BL = 8, $t_{DQSCK} < t_{CK}$


Figure 8 : tDQCKDL Timing


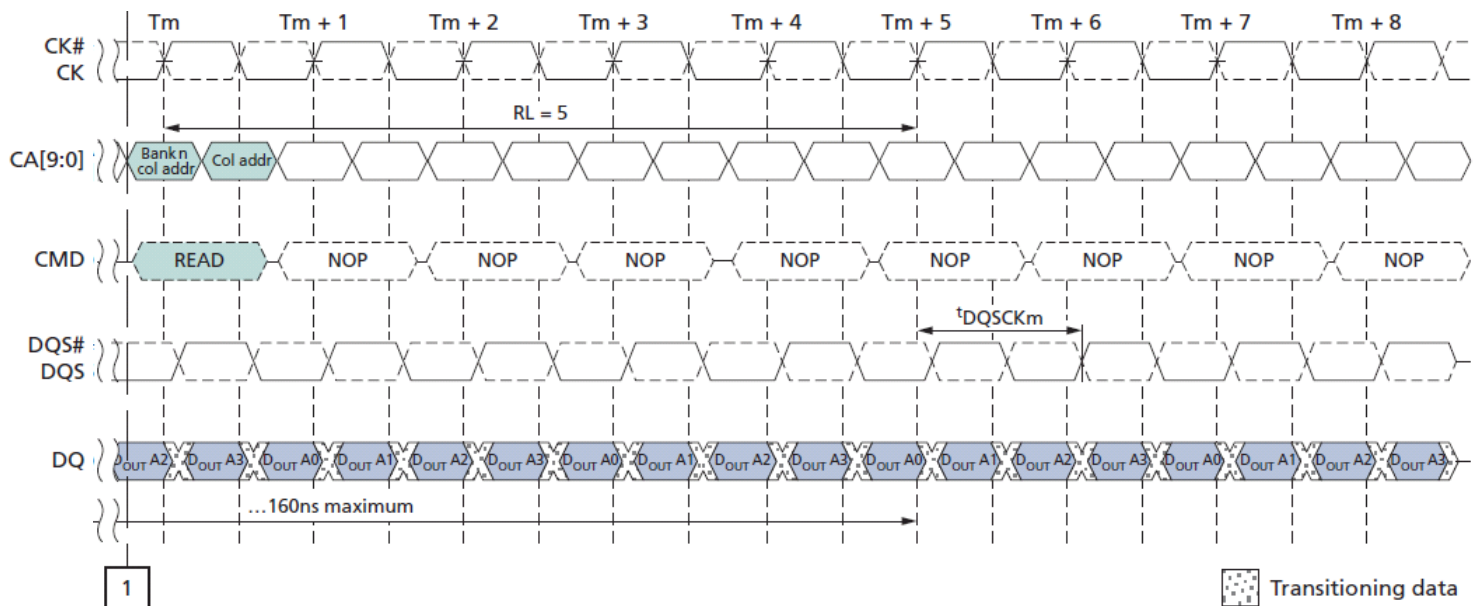
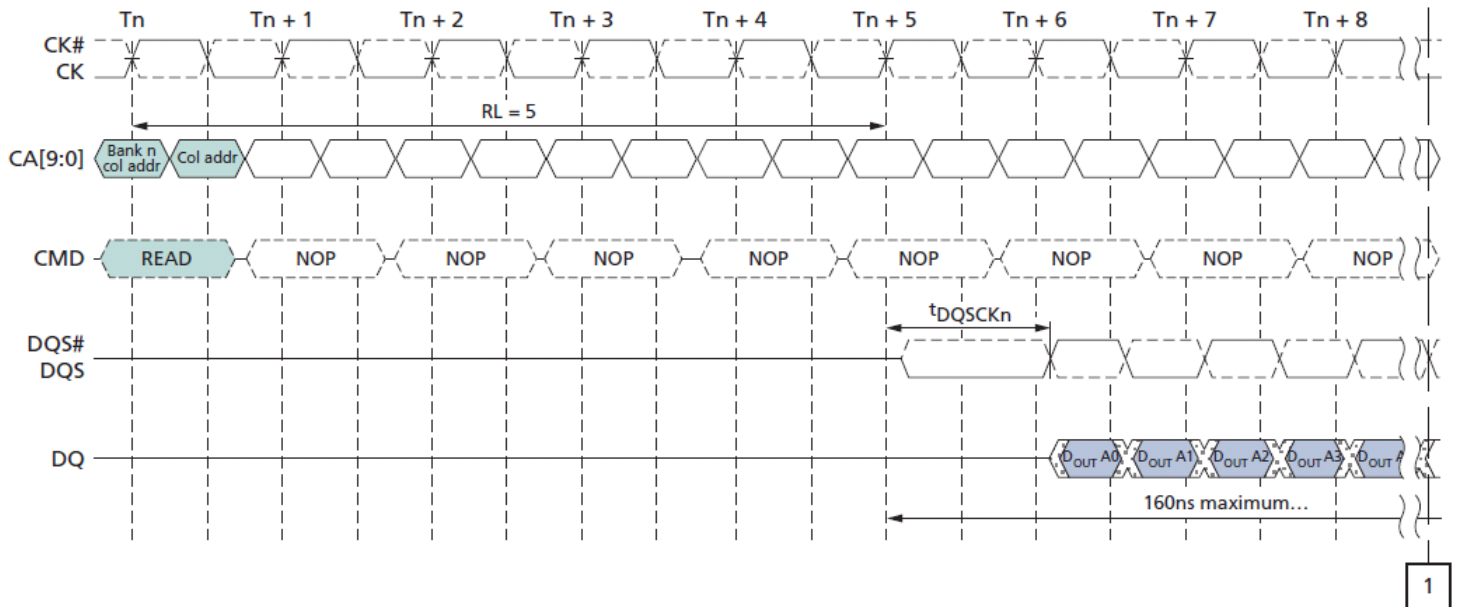
Notes : 1. $tDQCKDL = (tDQCK_n - tDQCK_m)$.

2. $tDQCKDL (MAX)$ is defined as the maximum of $ABS(tDQCK_n - tDQCK_m)$ for any $(tDQCK_n, tDQCK_m)$ pair within any 32ms rolling window.

Figure 9 : tDQSKDM Timing


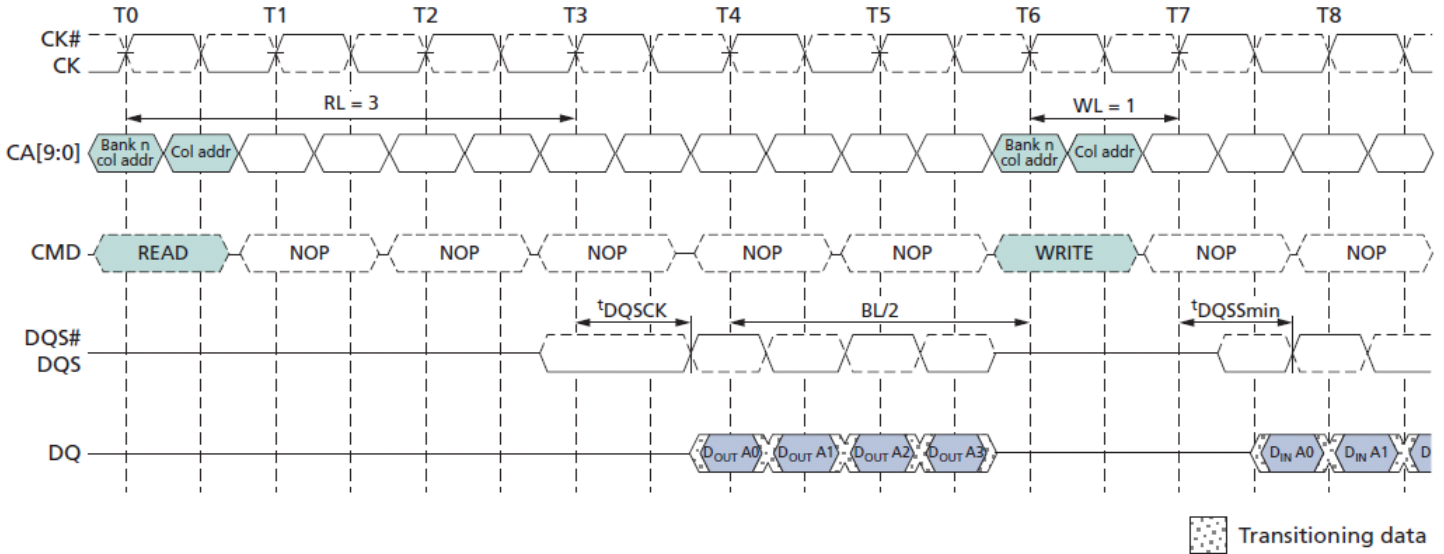
Notes : 1. $tDQSKDM = (tDQSKM_n - tDQSKM_m)$.

2. $tDQSKDM (MAX)$ is defined as the maximum of ABS ($tDQSKM_n - tDQSKM_m$) for any ($tDQSKM_n, tDQSKM_m$) pair within any 1.6µs rolling window.

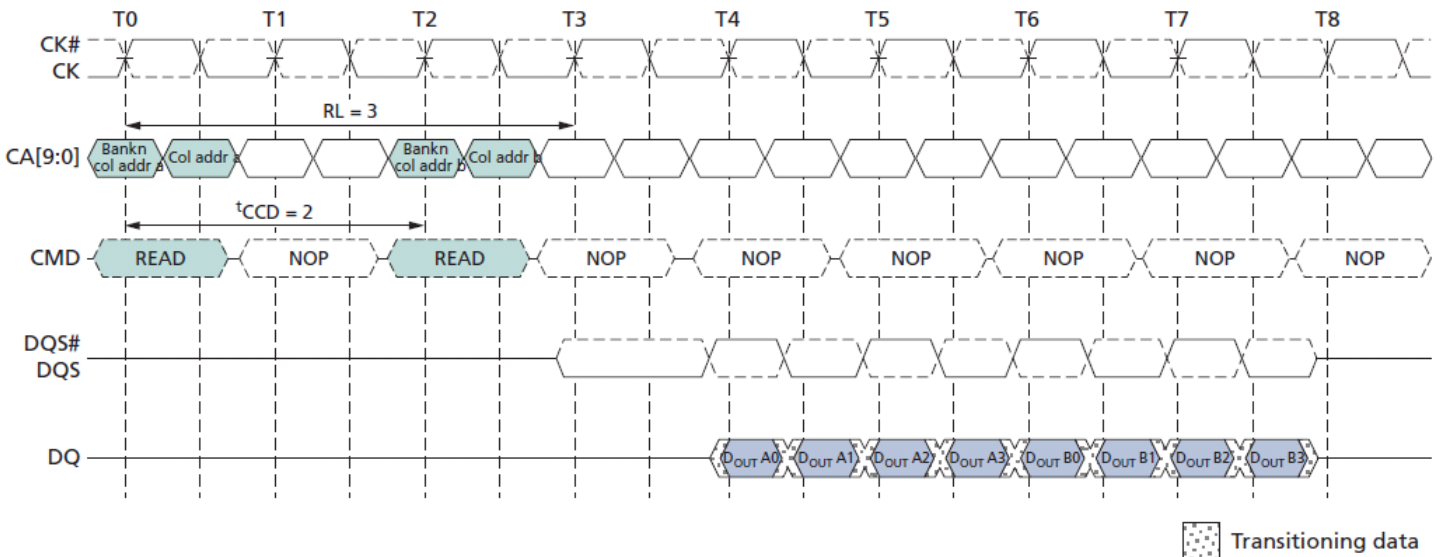
Figure 10 : tDQCKDS Timing

 Transitioning data

Notes : 1. $tDQCKDS = (tDQCKn - tDQCKm)$.

2. $tDQCKDS (MAX)$ is defined as the maximum of $ABS(tDQCKn - tDQCKm)$ for any $(tDQCKn, tDQCKm)$ pair for READs within a consecutive burst, within any 160ns rolling window.

Figure 11: Burst READ Followed by Burst WRITE – RL = 3, WL = 1, BL = 4


The minimum time from the burst READ command to the burst WRITE command is defined by the read latency (RL) and the burst length (BL). Minimum READ-to-WRITE latency is $RL + RU(t_{DQSCK}(MAX)/t_{CK}) + BL/2 + 1 - WL$ clock cycles. Note that if a READ burst is truncated with a burst TERMINATE (BST) command, the effective burst length of the truncated READ burst should be used for BL when calculating the minimum READ-to-WRITE delay.

Figure 12: Seamless Burst READ – RL = 3, BL = 4, CCD = 2


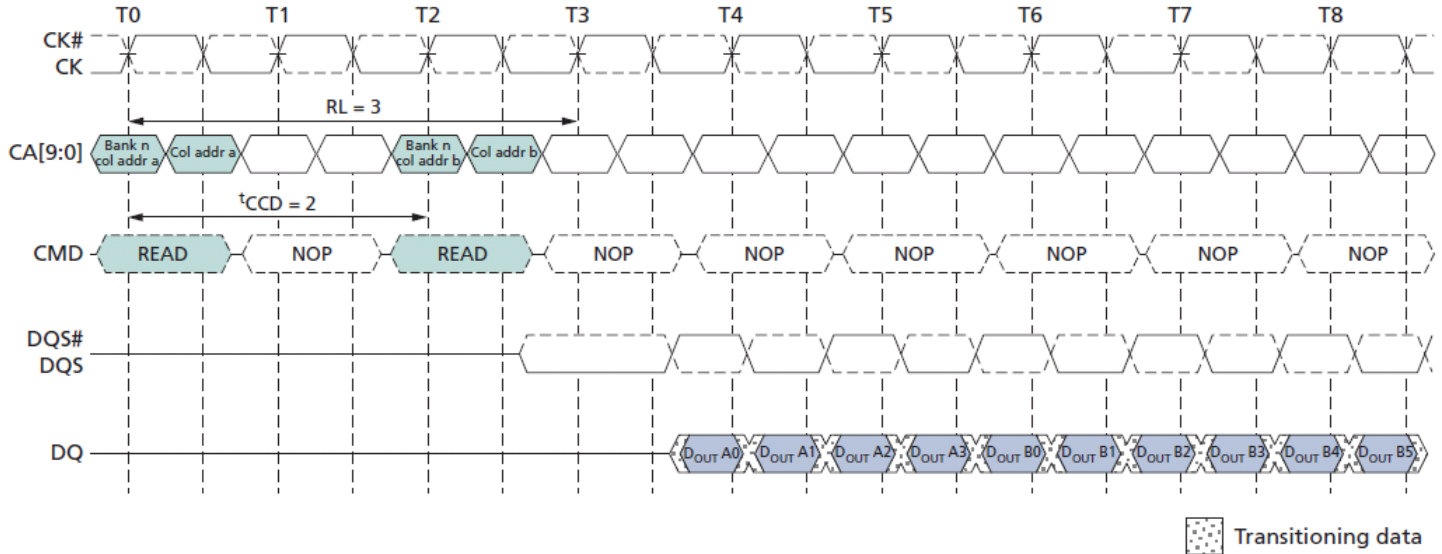
A seamless burst READ operation is supported by enabling a READ command at every other clock cycle for BL = 4 operation, every fourth clock cycle for BL = 8 operation, and every eighth clock cycle for BL = 16 operation. This operation is supported as long as the banks are activated, whether the accesses read the same or different banks.

READS Interrupted by a READ

A burst READ can be interrupted by another READ with a 4-bit burst boundary, provided that t_{CCD} is met.

A burst READ can be interrupted by other READS on any subsequent clock, provided that t_{CCD} is met.

Figure 13: READ Burst Interrupt Example – RL = 3, BL = 8, $t_{CCD} = 2$



Note : 1. READS can only be interrupted by other READS or the BST command.

Burst WRITE Command

The burstWRITE command is initiated with CS# LOW, CA0 HIGH, CA1 LOW, and CA2 LOW at the rising edge of the clock.

The command address bus inputs, CA5r–CA6r and CA1f–CA9f, determine the starting column address for the burst.

Write latency (WL) is defined from the rising edge of the clock on which theWRITE command is issued to the rising edge of the clock from which the t_{DQSS} delay is measured. The first valid data must be driven $WL \times t_{CK} + t_{DQSS}$ from the rising edge of the clock from which the WRITE command is issued. The data strobe signal (DQS) must be driven LOW t_{WPRE} prior to data input.

The burst cycle data bits must be applied to the DQ pins t_{DS} prior to the associated edge of the DQS and held valid until t_{DH} after that edge. Burst data is sampled on successive edges of the DQS until the 4-, 8-, or 16-bit burst length is completed.

After a burstWRITE operation, t_{WR} must be satisfied before a PRECHARGE command to the same bank can be issued.

Pin input timings are measured relative to the crosspoint of DQS and its complement, DQS#.

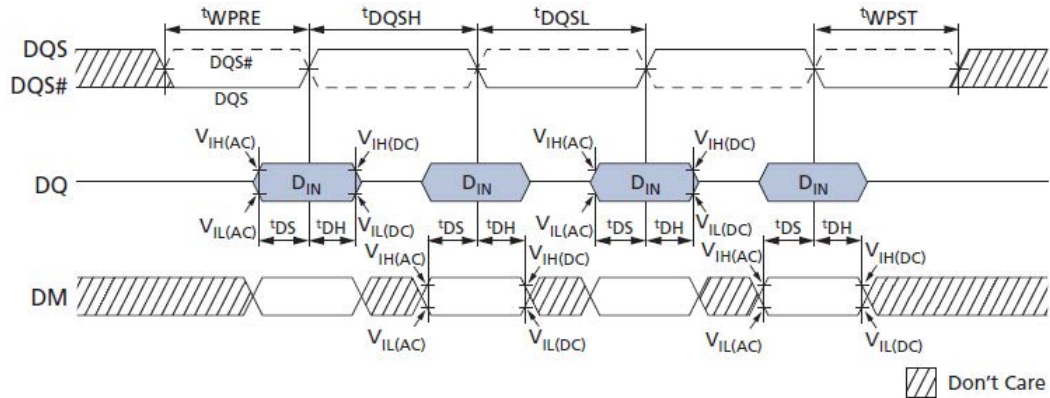
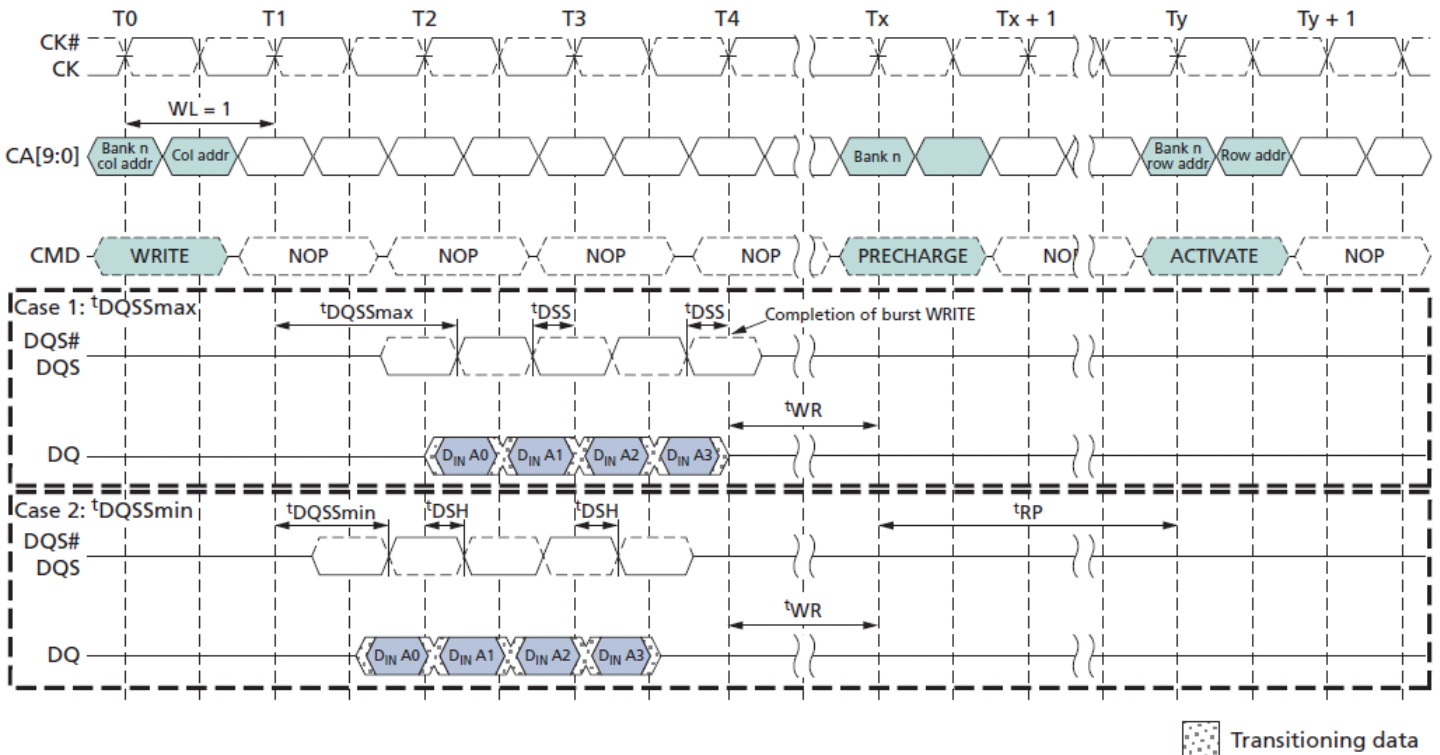
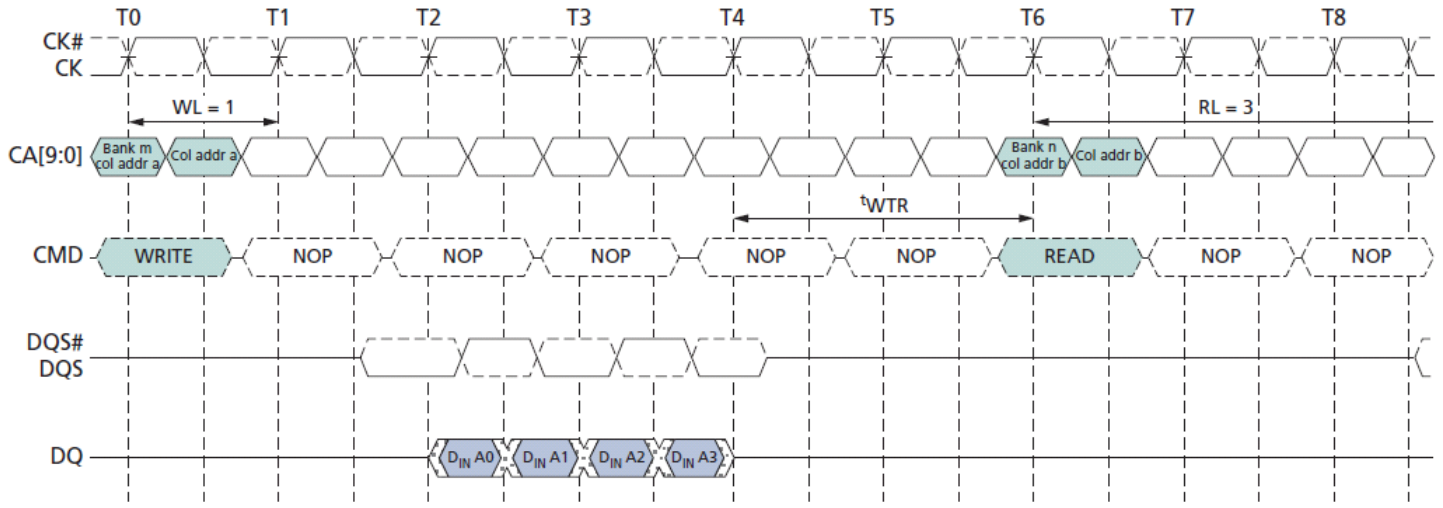

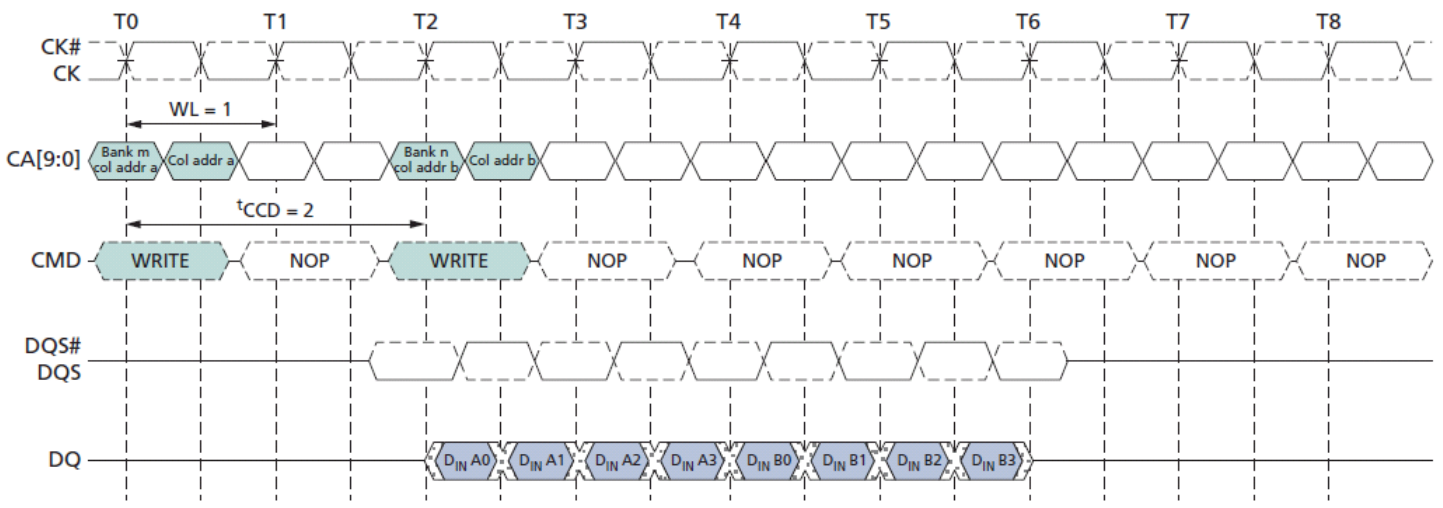

Figure 14 : Data Input (WRITE) Timing

Figure 15 : Burst WRITE – WL = 1, BL = 4


Figure 16: Burst WRITE Followed by Burst READ – RL = 3, WL = 1, BL = 4

 Transitioning data

- Notes :
1. The minimum number of clock cycles from the burst WRITE command to the burst READ command for any bank is $[WL + 1 + BL/2 + RU(t_{WTR} / t_{CK})]$.
 2. t_{WTR} starts at the rising edge of the clock after the last valid input data.
 3. If a WRITE burst is truncated with a BST command, the effective burst length of the truncated WRITE burst should be used as BL to calculate the minimum WRITE-to-READ delay.

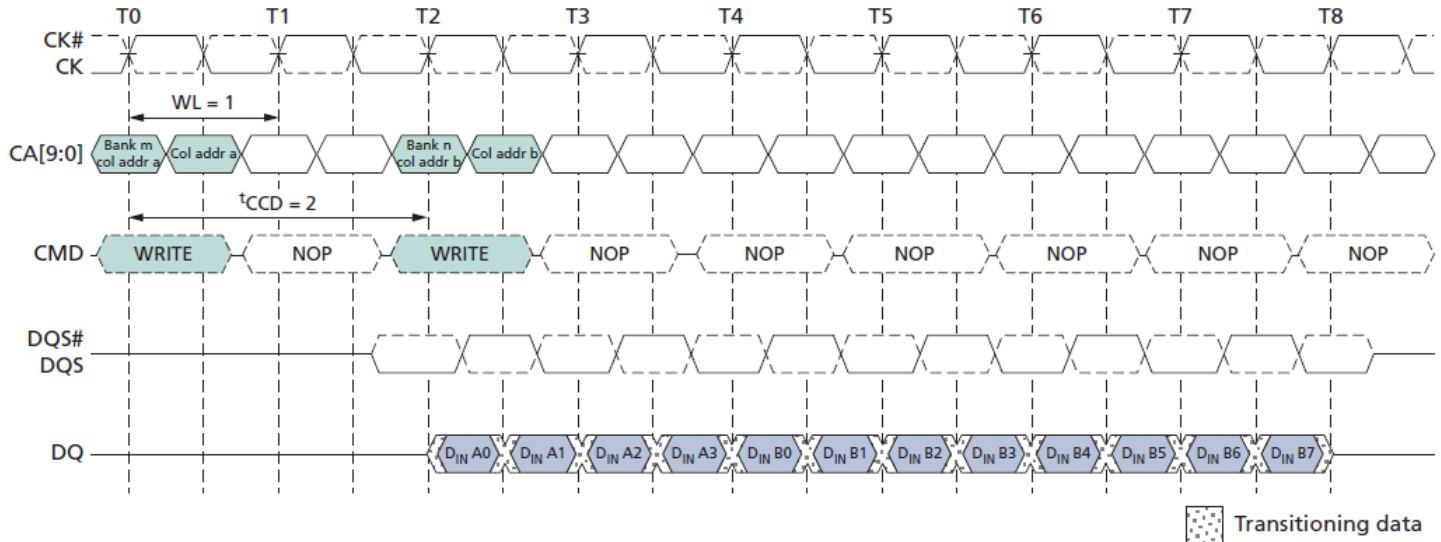
Figure 17 : Seamless Burst WRITE – WL = 1, BL = 4, t_{CCD} = 2

 Transitioning data

- Note :
1. The seamless burst WRITE operation is supported by enabling a WRITE command every other clock for BL = 4 operation, every four clocks for BL = 8 operation, or every eight clocks for BL = 16 operation. This operation is supported for any activated bank.

WRITES Interrupted by a WRITE

A burstWRITE can only be interrupted by anotherWRITE with a 4-bit burst boundary, provided that tCCD (MIN) is met. A WRITE burst interrupt can occur on even clock cycles after the initial WRITE command, provided that tCCD (MIN) is met.

Figure 18: WRITE Burst Interrupt Timing – WL = 1, BL = 8, tCCD = 2



Notes : 1. WRITES can only be interrupted by other WRITES or the BST command.

2. The effective burst length of the first WRITE equals two times the number of clock cycles between the first WRITE and the interrupting WRITE.

BURST TERMINATE Command

The BURST TERMINATE (BST) command is initiated with CS# LOW, CA0 HIGH, CA1 HIGH, CA2 LOW, and CA3 LOW at the rising edge of the clock. A BST command can only be issued to terminate an active READ or WRITE burst.

Therefore, a BST command can only be issued up to and including BL/2 - 1 clock cycles after a READ or WRITE command.

The effective burst length of a READ or WRITE command truncated by a BST command is as follows :

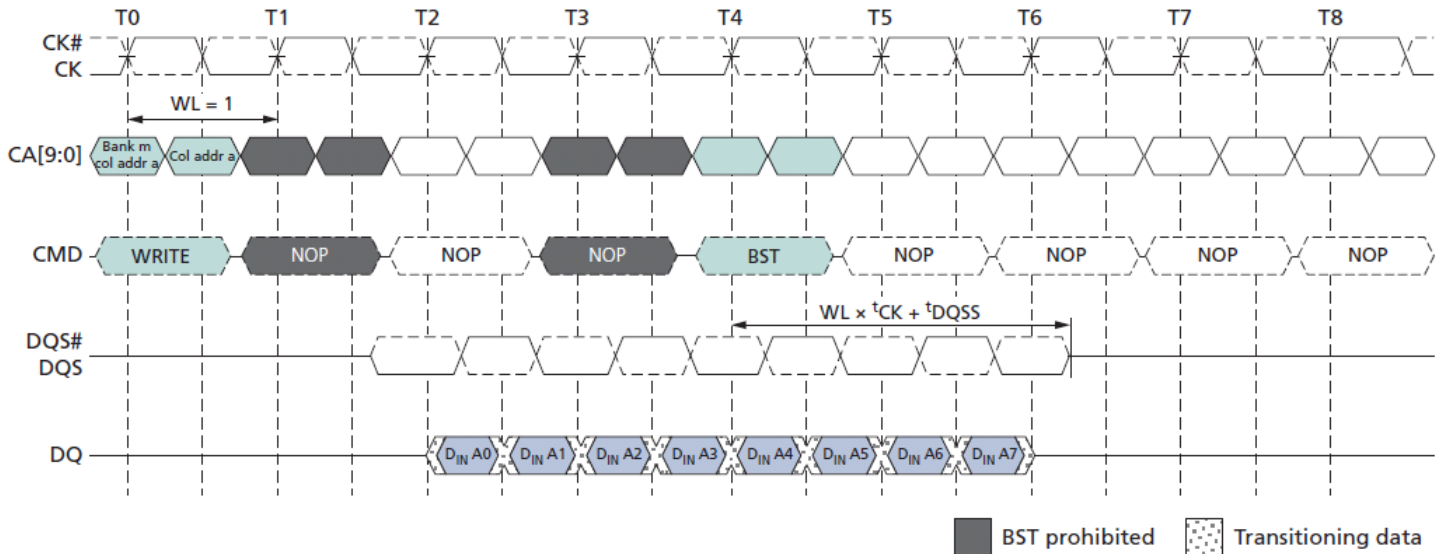
- Effective burst length = 2 × (number of clock cycles from the READ or WRITE command to the BST command).
- If a READ or WRITE burst is truncated with a BST command, the effective burst length of the truncated burst should be used for BL when calculating the minimum READ-to-WRITE or WRITE-to-READ delay.
- The BST command only affects the most recent READ or WRITE command.

The BST command truncates an ongoing READ burst $RL \times tCK + tDQSCK + tDQSQ$ after the rising edge of the clock where the BST command is issued.

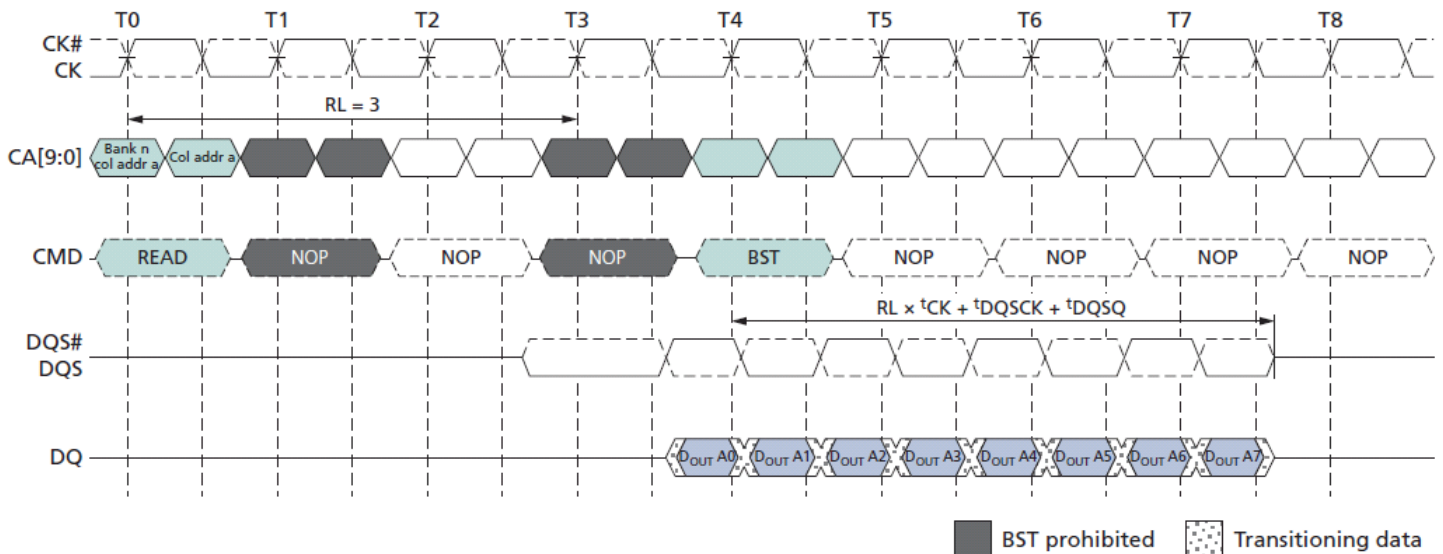
The BST command truncates an on going WRITE burst $WL \times tCK + tDQSS$ after the rising edge of the clock where the BST command is issued.

- The 4-bit prefetch architecture enables BST command assertion on even clock cycles following a WRITE or READ command.

The effective burst length of a READ or WRITE command truncated by a BST command is thus an integer multiple of four.

Figure 19 : Burst WRITE Truncated by BST – WL = 1, BL = 16


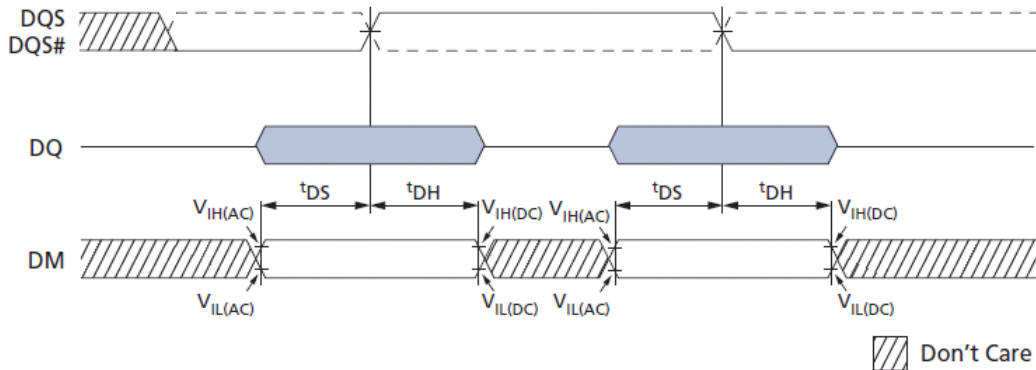
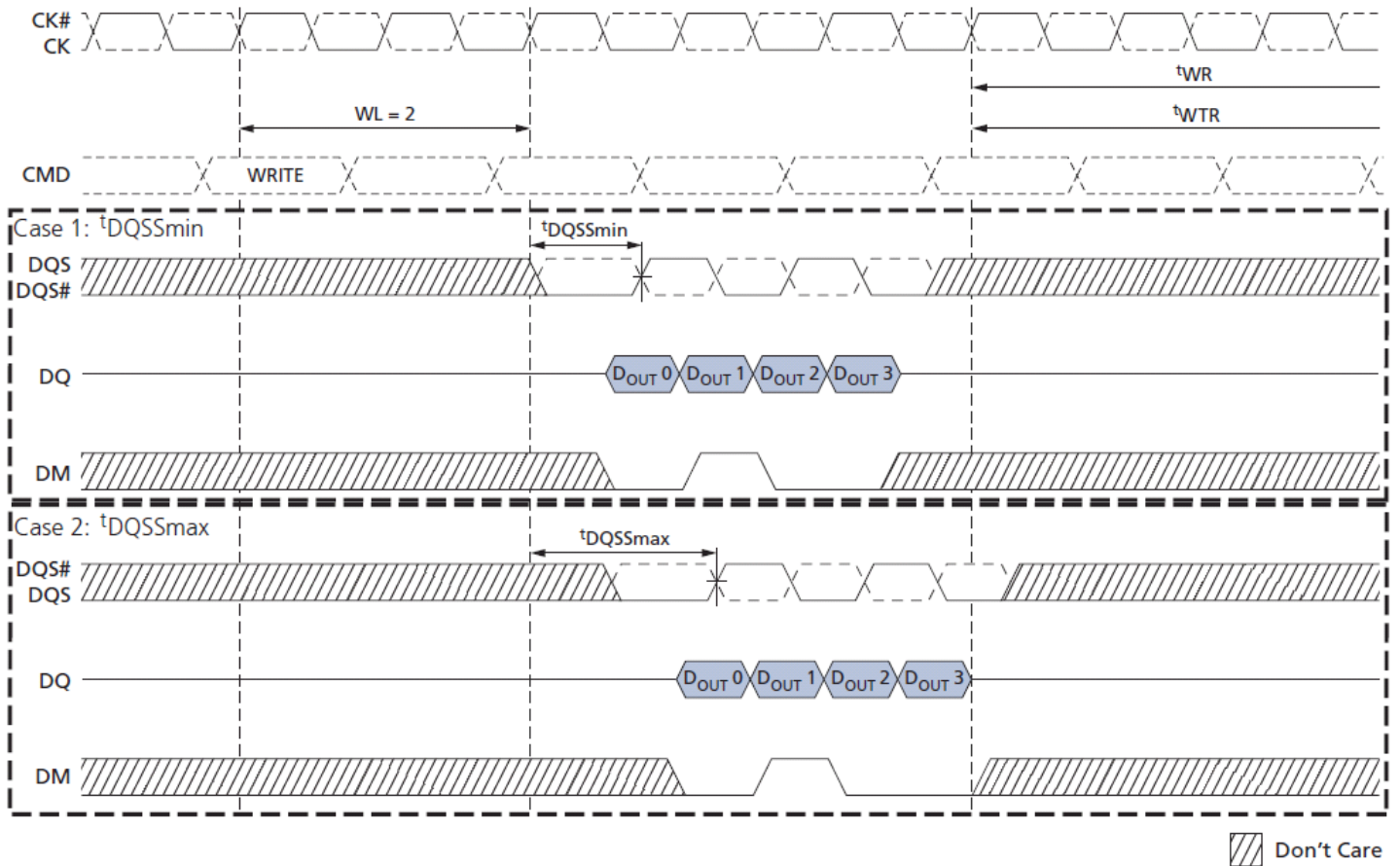
- Notes :
1. The BST command truncates an ongoing WRITE burst $WL \times tCK + tDQSS$ after the rising edge of the clock where the BST command is issued.
 2. BST can only be issued an even number of clock cycles after the WRITE command.
 3. Additional BST commands are not supported after T4 and must not be issued until after the next READ or WRITE command.

Figure 20: Burst READ Truncated by BST – RL = 3, BL = 16


- Notes :
1. The BST command truncates an ongoing READ burst $RL \times tCK + tDQSK + tDQSQ$ after the rising edge of the clock where the BST command is issued.
 2. BST can only be issued an even number of clock cycles after the READ command.
 3. Additional BST commands are not supported after T4 and must not be issued until after the next READ or WRITE command.

Write Data Mask

On LPDDR2 devices, one write data mask (DM) pin for each data byte (DQ) is supported, consistent with the implementation on LPDDR SDRAM. Each DM can mask its respective DQ for any given cycle of the burst. Data mask timings match data bit timing, but are inputs only. Internal data mask loading is identical to data bit loading to ensure matched system timing.

Figure 21: Data Mask Timing

Figure 22: Write Data Mask – Second Data Bit Masked


Note : 1. For the data mask function, WL = 2, BL = 4 is shown; the second data bit is masked.

PRECHARGE Command

The PRECHARGE command is used to precharge or close a bank that has been activated.

The PRECHARGE command is initiated with CS# LOW, CA0 HIGH, CA1 HIGH, CA2 LOW, and CA3 HIGH at the rising edge of the clock. The PRECHARGE command can be used to precharge each bank independently or all banks simultaneously. For 4-bank devices, the AB flag and bank address bits BA0 and BA1 are used to determine which bank(s) to precharge.

For 8-bank devices, the AB flag and the bank address bits BA0, BA1, and BA2 are used to determine which bank(s) to precharge.

The precharged bank(s) will be available for subsequent row access tRPab after an all bank PRECHARGE command is issued, or tRPpb after a single-bank PRECHARGE command is issued.

To ensure that 8-bank devices can meet the instantaneous current demand required to operate, the row precharge time (tRP) for an all bank PRECHARGE in 8-bank devices (tRPab) will be longer than the row precharge time for a single-bank PRECHARGE (tRPpb). ACTIVATE to PRECHARGE timing is shown in ACTIVATE Command (page 17).

Table 22: Bank Selection for PRECHARGE by Address Bits

| AB(CA4r) | BA2 (CA9r) | BA1 (CA8r) | BA0 (CA7r) | Precharged Bank(s) 8-Bank Device |
|----------|---------------|---------------|---------------|-------------------------------------|
| 0 | 0 | 0 | 0 | Bank 0 only |
| 0 | 0 | 0 | 1 | Bank 1 only |
| 0 | 0 | 1 | 0 | Bank 2 only |
| 0 | 0 | 1 | 1 | Bank 3 only |
| 0 | 1 | 0 | 0 | Bank 4 only |
| 0 | 1 | 0 | 1 | Bank 5 only |
| 0 | 1 | 1 | 0 | Bank 6 only |
| 0 | 1 | 1 | 1 | Bank 7 only |
| 1 | Don't Care | Don't Care | Don't Care | All Banks |

READ Burst Followed by PRECHARGE

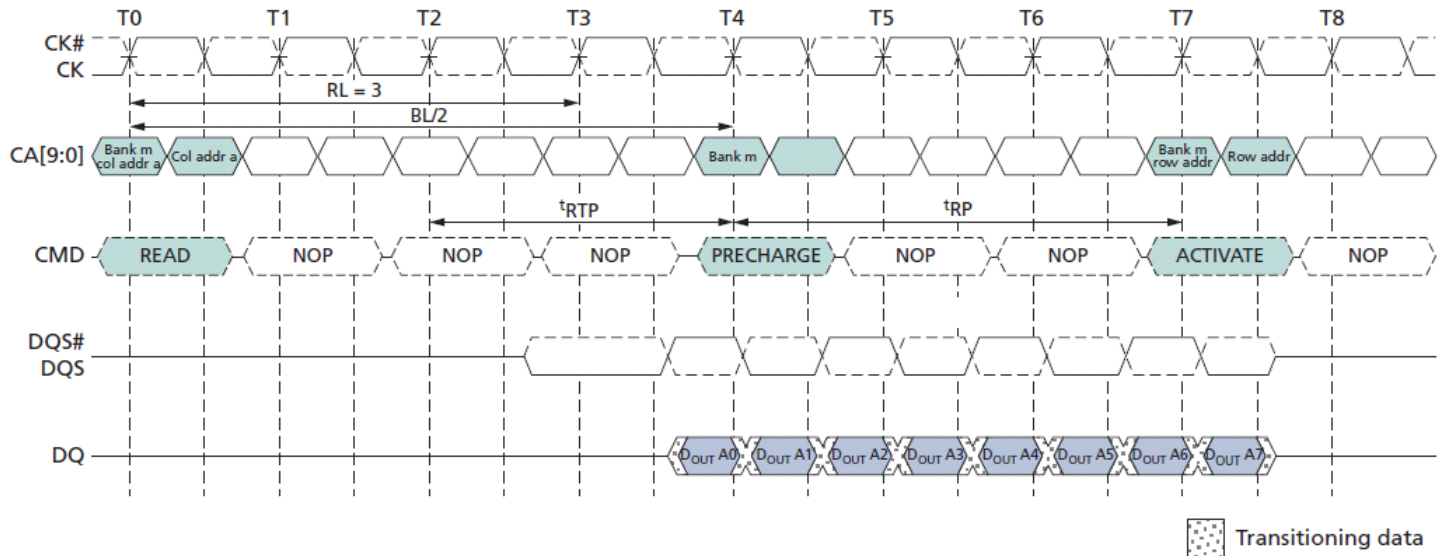
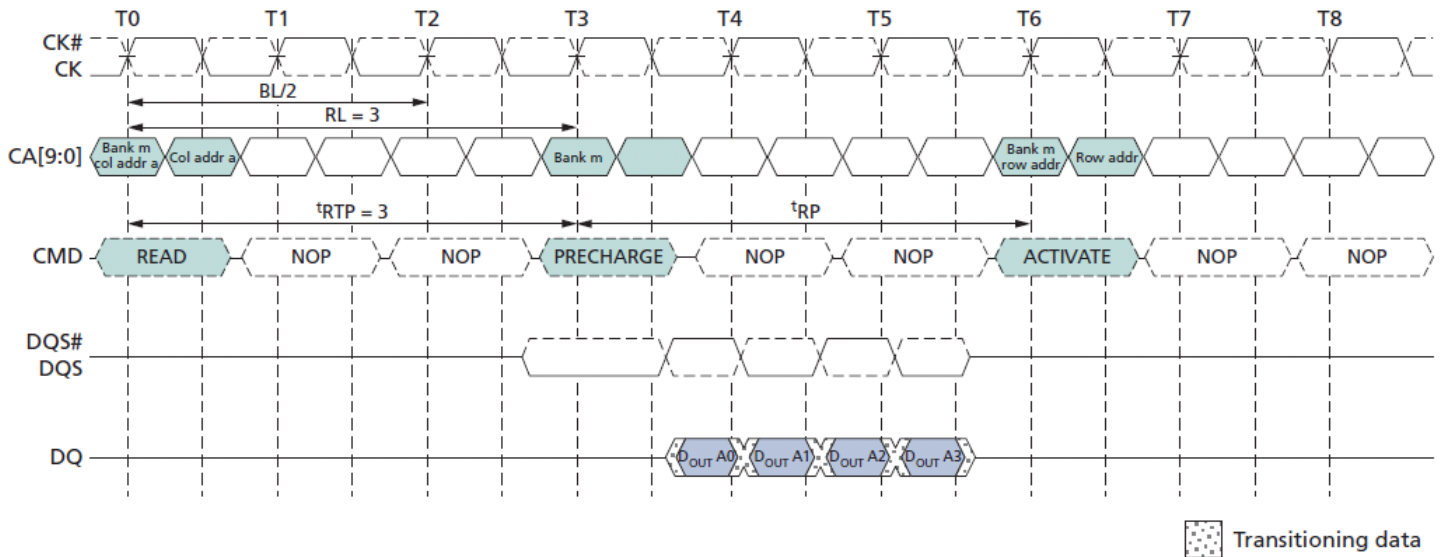
For the earliest possible precharge, the PRECHARGE command can be issued BL/2 clock cycles after a READ command.

A new bank ACTIVATE command can be issued to the same bank after the row precharge time (tRP) has elapsed.

A PRECHARGE command cannot be issued until after tRAS is satisfied.

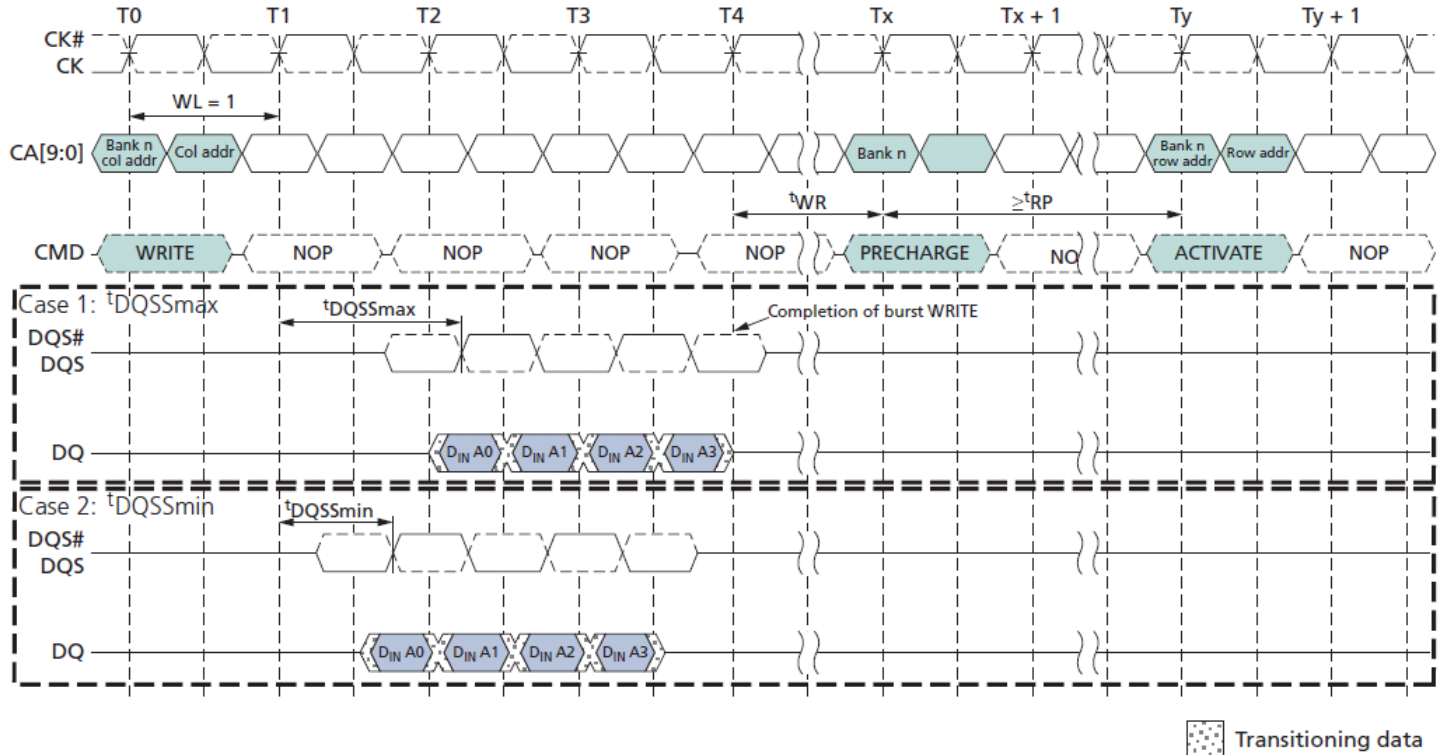
The minimum READ-to-PRECHARGE time (tRTP) must also satisfy a minimum analog time from the rising clock edge that initiates the last 4-bit prefetch of a READ command. tRTP begins BL/2 - 2 clock cycles after the READ command.

If the burst is truncated by a BST command, the effective BL value is used to calculate when tRTP begins.

Figure 23: READ Burst Followed by PRECHARGE – RL = 3, BL = 8, RU(tRTP(MIN)/tCK) = 2

Figure 24: READ Burst Followed by PRECHARGE – RL = 3, BL = 4, RU(tRTP(MIN)/tCK) = 3


WRITE Burst Followed by PRECHARGE

For WRITE cycles, aWRITE recovery time (tWR) must be provided before a PRECHARGE command can be issued. tWR delay is referenced from the completion of the burst WRITE. The PRECHARGE command must not be issued prior to the tWR delay. For WRITE-to-PRECHARGE timings see Table 23. These devices write data to the array in prefetch quadruples (prefetch = 4). An internal WRITE operation can only begin after a prefetch group has been completely latched. The minimumWRITE-to-PRECHARGE time for commands to the same bank is WL + BL/2 + 1 + RU(tWR/tCK) clock cycles. For untruncated bursts, BL is the value set in the mode register. For truncated bursts, BL is the effective burst length.

Figure 25 : WRITE Burst Followed by PRECHARGE – WL = 1, BL = 4


Auto Precharge

Before a new row can be opened in an active bank, the active bank must be precharged using either the PRECHARGE command or the auto precharge function. When a READ or WRITE command is issued to the device, the auto precharge bit (AP) can be set to enable the active bank to automatically begin precharge at the earliest possible moment during the burst READ or WRITE cycle. If AP is LOW when the READ or WRITE command is issued, then normal READ or WRITE burst operation is executed and the bank remains active at the completion of the burst.

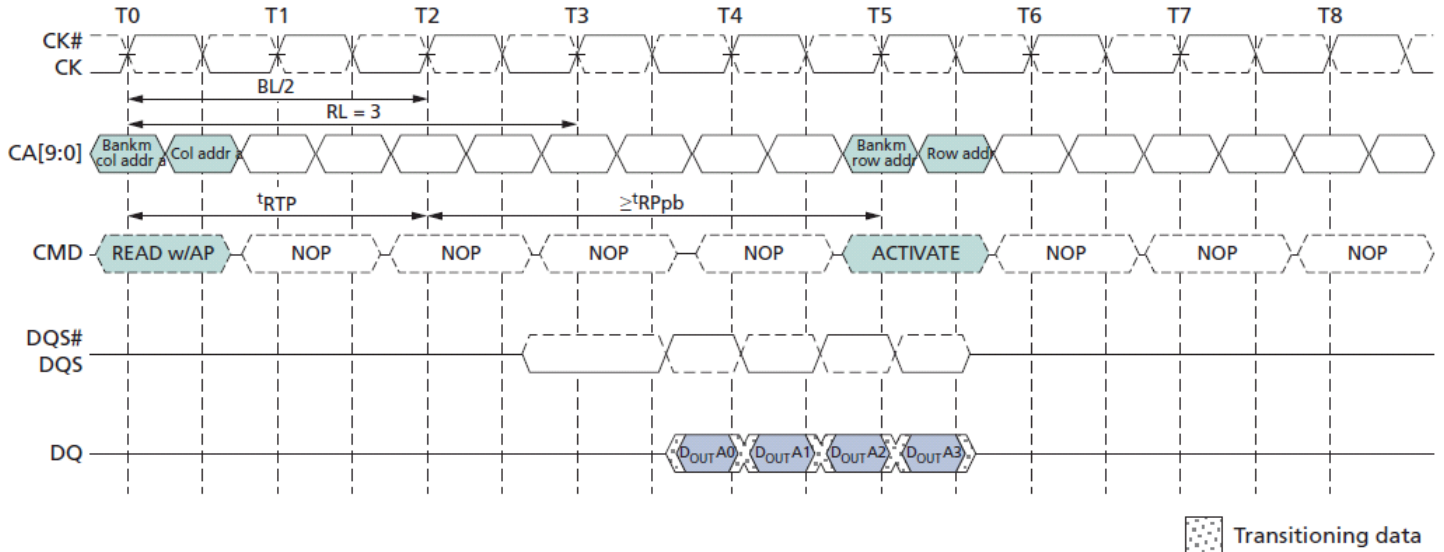
If AP is HIGH when the READ or WRITE command is issued, the auto precharge function is engaged. This feature enables the PRECHARGE operation to be partially or completely hidden during burst READ cycles (dependent upon READ or WRITE latency), thus improving system performance for random data access.

READ Burst with Auto Precharge

If AP (CA0f) is HIGH when a READ command is issued, the READ with auto precharge function is engaged.

These devices start an auto precharge on the rising edge of the clock BL/2 or BL/2 - 2 + RU(tRTP/tCK) clock cycles later than the READ with auto precharge command, whichever is greater. For auto precharge calculations see Table 23. Following an auto precharge operation, an ACTIVATE command can be issued to the same bank if the following two conditions are satisfied simultaneously:

- The RAS precharge time (tRP) has been satisfied from the clock at which the auto precharge begins.
- The RAS cycle time (tRC) from the previous bank activation has been satisfied.

Figure 26 : READ Burst with Auto Precharge – RL = 3, BL = 4, RU(tRTP(MIN)/tCK) = 2


WRITE Burst with Auto Precharge

If AP (CA0f) is HIGH when a WRITE command is issued, the WRITE with auto precharge function is engaged.

The device starts an auto precharge at the clock rising edge t_{WR} cycles after the completion of the burst WRITE. Following a WRITE with auto precharge, an ACTIVATE command can be issued to the same bank if the following two conditions are met:

- The RAS precharge time (t_{RP}) has been satisfied from the clock at which the auto precharge begins.
- The RAS cycle time (t_{RC}) from the previous bank activation has been satisfied.

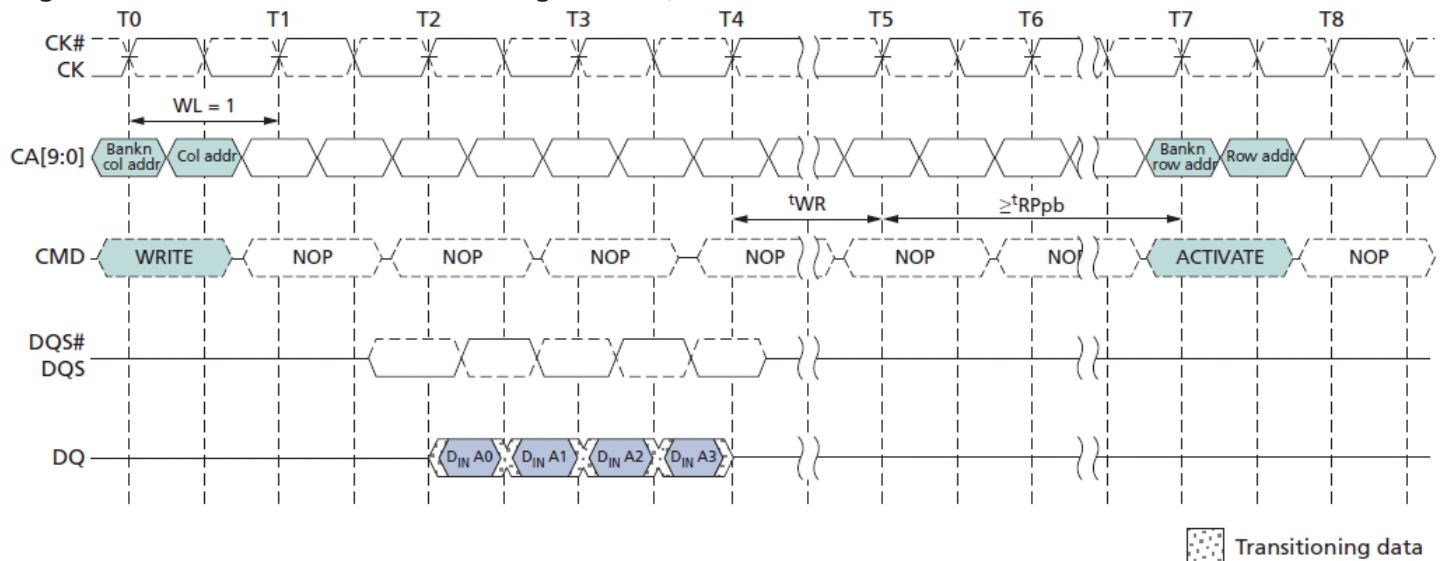
Figure 27 : Write Burst with Auto Precharge – WL=1, BL=4


Table23 : Precharge and Auto Precharge Clarification

| From Command | To Command | Minimum Delay Between Commands | Unit | Notes |
|---------------|--------------------------------------|--|------|-------|
| READ | Precharge to same bank as read | $BL/2 + \text{MAX}(2, RU(tRTP/tCK)) - 2$ | CLK | 1 |
| | Precharge all | $BL/2 + \text{MAX}(2, RU(tRTP/tCK)) - 2$ | CLK | 1 |
| BST | Precharge to same bank as read | 1 | CLK | 1 |
| | Precharge all | 1 | CLK | 1 |
| READ w/AP | Precharge to same bank as read w/AP | $BL/2 + \text{MAX}(2, RU(tRTP/tCK)) - 2$ | CLK | 1, 2 |
| | Precharge all | $BL/2 + \text{MAX}(2, RU(tRTP/tCK)) - 2$ | CLK | 1 |
| | Activate to same bank as read w/AP | $BL/2 + \text{MAX}(2, RU(tRTP/tCK)) - 2 + RU(tRPpb/tCK)$ | CLK | 1 |
| | Write or WRITE w/AP (same bank) | Illegal | CLK | 3 |
| | Write or WRITE w/AP (different bank) | $RL + BL/2 + RU(tDQSCkmax/tCK) - WL + 1$ | CLK | 3 |
| | Read or read w/AP (same bank) | Illegal | CLK | 3 |
| WRITE | Precharge to same bank as write | $WL + BL/2 + RU(tWR/tCK) + 1$ | CLK | 1 |
| | Precharge all | $WL + BL/2 + RU(tWR/tCK) + 1$ | CLK | 1 |
| BST | Precharge to same bank as write | $WL + RU(tWR/tCK) + 1$ | CLK | 1 |
| | Precharge all | $WL + RU(tWR/tCK) + 1$ | CLK | 1 |
| WRITE w/AP | Precharge to same bank as WRITE w/AP | $WL + BL/2 + RU(tWR/tCK) + 1$ | CLK | 1, 2 |
| | Precharge all | $WL + BL/2 + RU(tWR/tCK) + 1$ | CLK | 1 |
| | Activate to same bank as write w/AP | $WL + BL/2 + RU(tWR/tCK) + 1 + RU(tRPpb/tCK)$ | CLK | 1 |
| | Write or WRITE w/ap (same bank) | Illegal | CLK | 3 |
| | Write or WRITE w/ap (different bank) | $BL/2$ | CLK | 3 |
| | Read or read w/ap (same bank) | Illegal | CLK | 3 |
| Precharge | Precharge to same bank as precharge | 1 | CLK | 1 |
| | Precharge all | 1 | CLK | 1 |
| Precharge all | Precharge | 1 | CLK | 1 |
| | Precharge all | 1 | CLK | 1 |

Notes : 1. For a given bank, the PRECHARGE period should be counted from the latest PRECHARGE command either a one-bank RECHARGE or PRECHARGE ALL issued to that bank.

The PRECHARGE period is satisfied after tRP, depending on the latest PRECHARGE command issued to that bank.

2. Any command issued during the specified minimum delay time is illegal.

3. After READ with auto precharge, seamless READ operations to different banks are supported. After WRITE with auto precharge, seamless WRITE operations to different banks are supported. READ with auto precharge and WRITE with auto precharge must not be interrupted or truncated.

REFRESH Command

The REFRESH command is initiated with CS# LOW, CA0 LOW, CA1 LOW, and CA2 HIGH at the rising edge of the clock.

Per-bank REFRESH is initiated with CA3 LOW at the rising edge of the clock. All-bank REFRESH is initiated with CA3 HIGH at the rising edge of the clock. Per-bank REFRESH is only supported in devices with eight banks.

A per-bank REFRESH command (REFpb) performs a per-bank REFRESH operation to the bank scheduled by the bank counter in the memory device. The bank sequence for per-bank REFRESH is fixed to be a sequential round-robin :

0-1-2-3-4-5-6-7-0-1-.... The bank count is synchronized between the controller and the SDRAM by resetting the bank count to zero.

Synchronization can occur upon issuing a RESET command or at every exit from self refresh.

Bank addressing for the per-bank REFRESH count is the same as established for the single-bank PRECHARGE command (see Table 22). A bank must be idle before it can be refreshed. The controller must track the bank being refreshed by the per-bank REFRESH command. The REFpb command must not be issued to the device until the following conditions have been met:

- tRFCab has been satisfied after the prior REFab command.
- tRFCpb has been satisfied after the prior REFpb command.
- tRP has been satisfied after the prior PRECHARGE command to that bank .
- tRRD has been satisfied after the prior ACTIVATE command (if applicable, for example after activating a row in a different bank than the one affected by the REFpb command).

The target bank is inaccessible during per-bank REFRESH cycle time (tRFCpb), however, other banks within the device are accessible and can be addressed during the cycle.

During the REFpb operation, any of the banks other than the one being refreshed can be maintained in an active state or accessed by a READ or WRITE command. When the per-bank REFRESH cycle has completed, the affected bank will be in the idle state.

After issuing REFpb, the following conditions must be met:

- tRFCpb must be satisfied before issuing a REFab command.
- tRFCpb must be satisfied before issuing an ACTIVATE command to the same bank.
- tRRD must be satisfied before issuing an ACTIVATE command to a different bank.
- tRFCpb must be satisfied before issuing another REFpb command.

An all-bank REFRESH command (REFab) issues a REFRESH command to all banks.

All banks must be idle when REFab is issued (for instance, by issuing a PRECHARGE ALL command prior to issuing an all-bank REFRESH command). REFab also synchronizes the bank count between the controller and the SDRAM to zero.

The REFab command must not be issued to the device until the following conditions have been met:

- tRFCab has been satisfied following the prior REFab command.
- tRFCpb has been satisfied following the prior REFpb command.
- tRP has been satisfied following the prior PRECHARGE commands.

After an all-bank REFRESH cycle has completed, all banks will be idle. After issuing REFab:

- tRFCab latency must be satisfied before issuing an ACTIVATE command.
- tRFCab latency must be satisfied before issuing a REFab or REFpb command.

Table24 : Refresh Command Scheduling Separation Requirements

| Symbol | Minimum delay From | To | Notes |
|--------|--------------------|--|-------|
| tRFCab | REFab | REFab | |
| | | ACTIVATE command to any bank | |
| | | REFpb | |
| tRFCpb | REFpb | REFab | |
| | | ACTIVATE command to same bank as REFpb | |
| | | REFpb | |
| tRRD | REFpb | ACTIVATE command to a different bank than REFpb | |
| | ACTIVATE | REFpb | 1 |
| | | ACTIVATE command to a different bank than the prior ACTIVATE command | |

Note : 1. A bank must be in the idle state before it is refreshed, so REFab is prohibited following an ACTIVATE command.
REFpb is supported only if it affects a bank that is in the idle state.

Mobile LPDDR2 devices provide significant flexibility in scheduling REFRESH commands as long as the required boundary conditions are met (see Figure 32).

In the most straightforward implementations, a REFRESH command should be scheduled every tREFI. In this case, self refresh can be entered at any time. Users may choose to deviate from this regular refresh pattern, for instance, to enable a period in which no refresh is required. As an example, using a 1Gb LPDDR2 device, the user can choose to issue a refresh burst of 4096 REFRESH commands at the maximum supported rate (limited by tREFBW), followed by an extended period without issuing any REFRESH commands, until the refresh window is complete. The maximum supported time without REFRESH commands is calculated as follows :

$$tREFW - (R/8) \times tREFBW = tREFW - R \times 4 \times tRFCab.$$

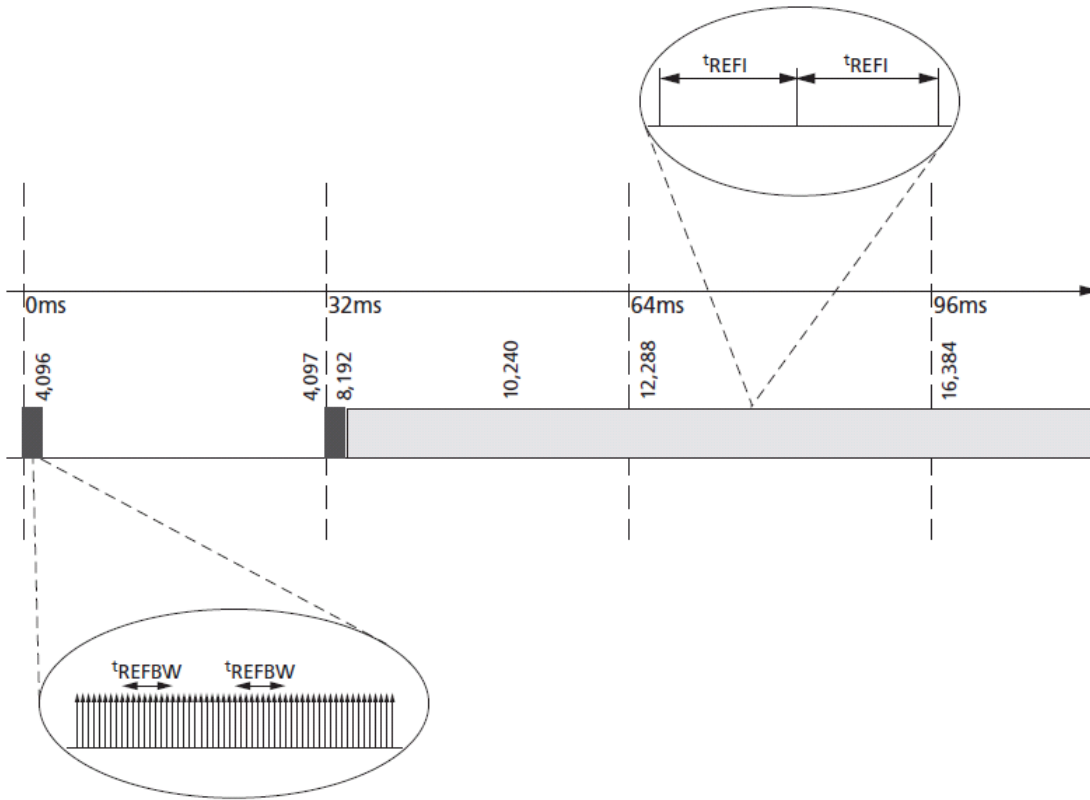
For example, a 1Gb device at TC ≤ 85°C can be operated without a refresh for up to 32ms - 4096 × 4 × 130ns ≈ 30ms.

Both the regular and the burst/pause patterns can satisfy refresh requirements if they are repeated in every 32ms window. It is critical to satisfy the refresh requirement in every rolling refresh window during refresh pattern transitions.

The supported transition from a burst pattern to a regular distributed pattern is shown in Figure 28. If this transition occurs immediately after the burst refresh phase, all rolling tREFW intervals will meet the minimum required number of REFRESH commands.

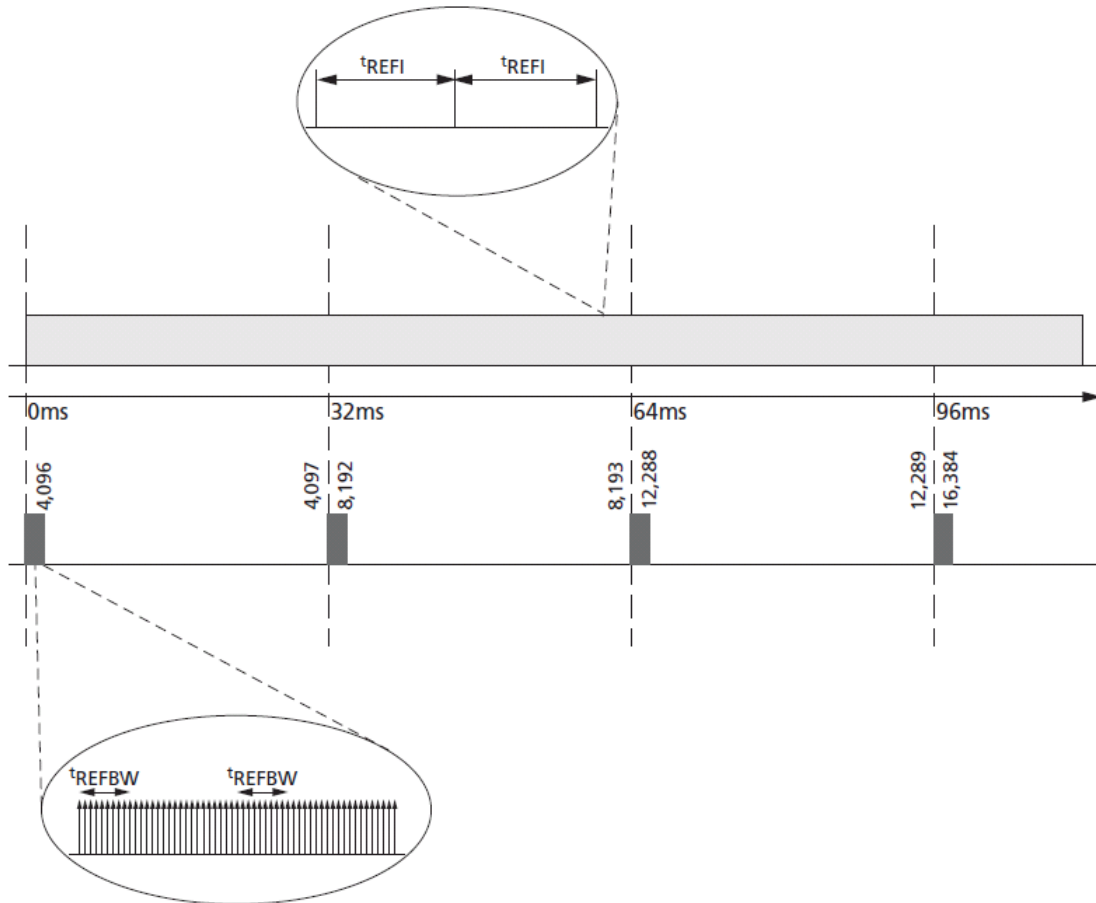
A nonsupported transition is shown in Figure 55. In this example, the regular refresh pattern starts after the completion of the pause phase of the burst/pause refresh pattern. For several rolling tREFW intervals, the minimum number of REFRESH commands is not satisfied.

Understanding this pattern transition is extremely important, even when only one pattern is employed. In self refresh mode, a regular distributed refresh pattern must be assumed. Alliance Memory recommends entering self refresh mode immediately following the burst phase of a burst/pause refresh pattern; upon exiting self refresh, begin with the burst phase (see Figure 31).

Figure28 : Regular Distributed Refresh Pattern


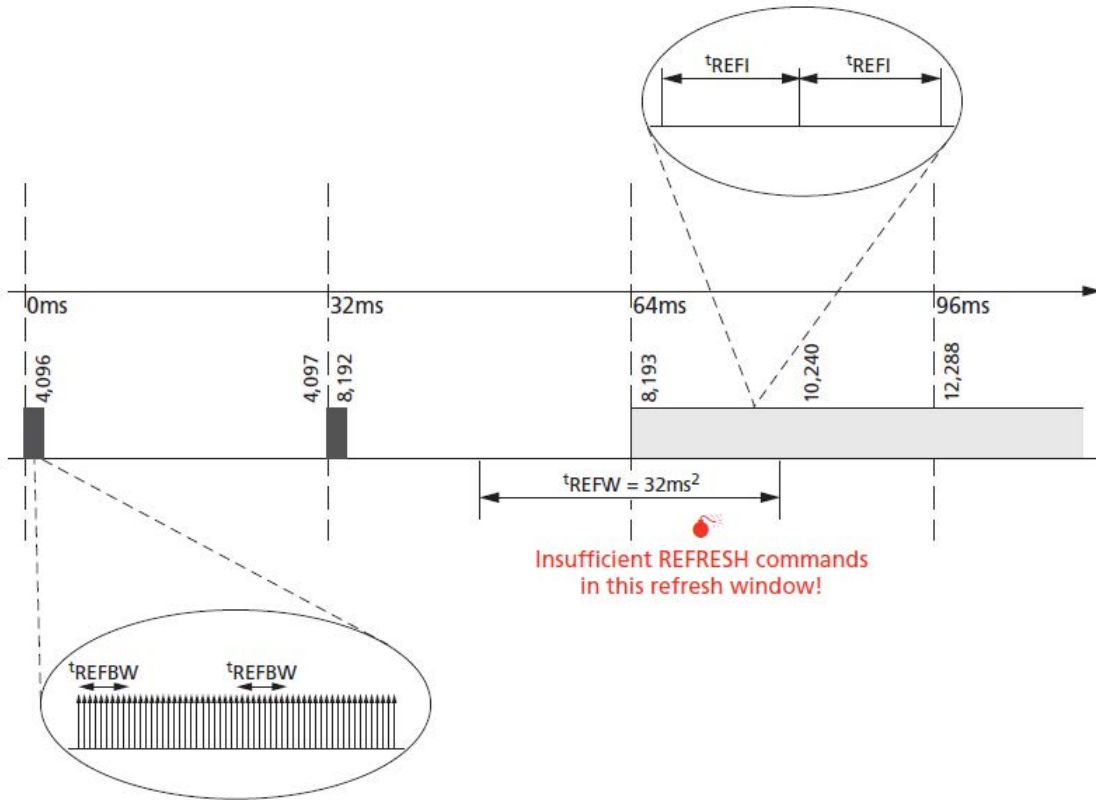
Notes : 1. Compared to repetitive burst REFRESH with subsequent REFRESH pause.

2. As an example, in a 1Gb LPDDR2 device at $TC \leq 85^{\circ}C$, the distributed refresh pattern has one REFRESH command per $7.8\mu s$; the burst refresh pattern has one REFRESH command per $0.52\mu s$, followed by $\approx 30ms$ without any REFRESH command.

Figure29 : Supported Transition from Repetitive REFRESH Burst


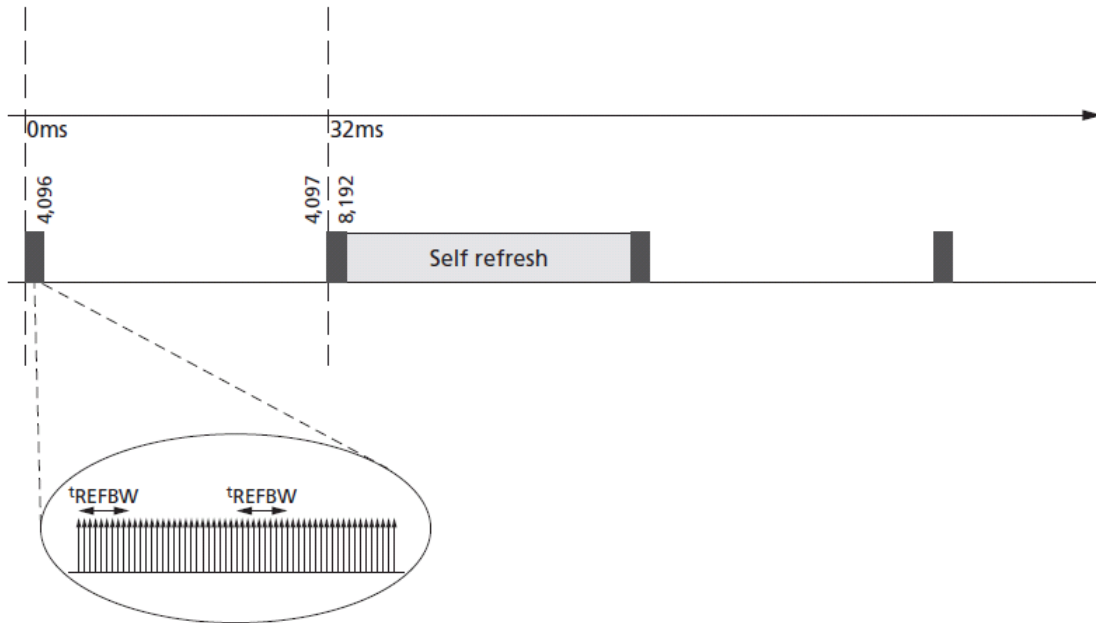
Notes : 1. Shown with subsequent REFRESH pause to regular distributed refresh pattern.

2. As an example, in a 1Gb LPDDR2 device at $TC \leq 85^{\circ}C$, the distributed refresh pattern has one REFRESH command per $7.8\mu s$; the burst refresh pattern has one REFRESH command per $0.52\mu s$, followed by $\approx 30ms$ without any REFRESH command.

Figure30 : Nonsupported Transition from Repetitive REFRESH Burst


Notes : 1. Shown with subsequent REFRESH pause to regular distributed refresh pattern.

2. There are only ≈ 2048 REFRESH commands in the indicated t_{REFW} window. This does not provide the required minimum number of REFRESH commands (R). PDF:

Figure31 : Recommended Self Refresh Entry and Exit


Note : 1. In conjunction with a burst/pause refresh pattern.

REFRESH Requirements

1. Minimum Number of REFRESH Commands

Mobile LPDDR2 requires a minimum number, R, of REFRESH (REFab) commands within any rolling refresh window ($t_{REFW} = 32 \text{ ms} @ \text{MR4}[2:0] = 011$ or $\text{TC} \leq 85^\circ\text{C}$). For actual values per density and the resulting average refresh interval (t_{REFI}), (see Table 75).

For t_{REFW} and t_{REFI} refresh multipliers at different MR4 settings, see the MR4 Device Temperature (MA[7:0] = 04h) table.

For devices supporting per-bank REFRESH, a REFab command can be replaced by a full cycle of eight REFpb commands.

2. Burst REFRESH Limitation

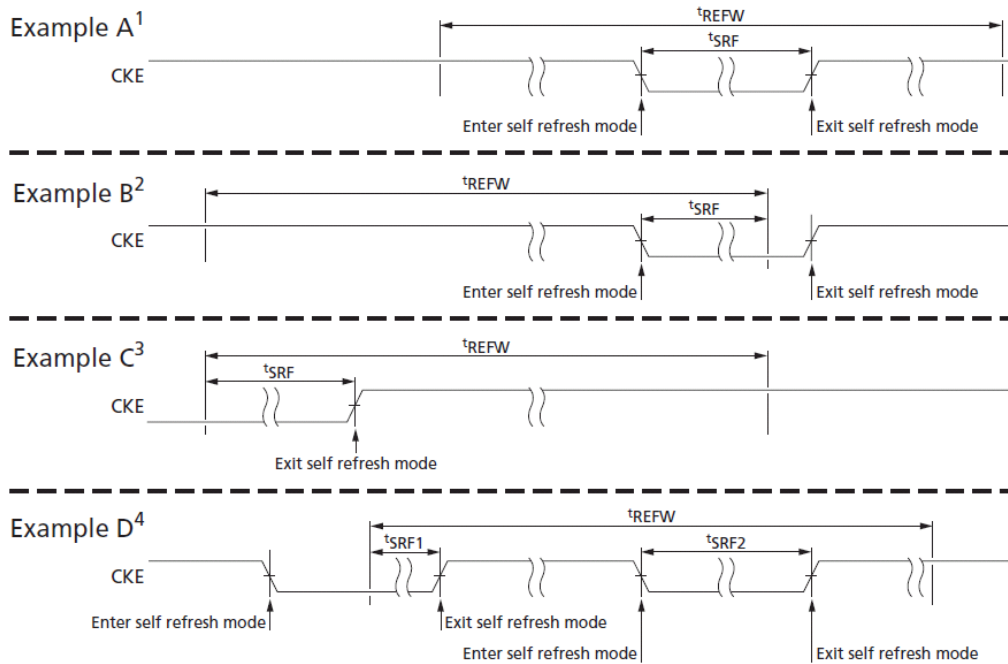
To limit current consumption, a maximum of eight REFab commands can be issued in any rolling t_{REFBW} ($t_{REFBW} = 4 \times 8 \times t_{RFCab}$). This condition does not apply if REFpb commands are used.

3. REFRESH Requirements and Self Refresh

If any time within a refresh window is spent in self refresh mode, the number of required REFRESH commands in that window is reduced to the following:

$$R' = RU\left(\frac{t_{SRF}}{t_{REFI}}\right) = R - RU\left(R \times \frac{t_{SRF}}{t_{REFW}}\right)$$

Where RU represents the round-up function.

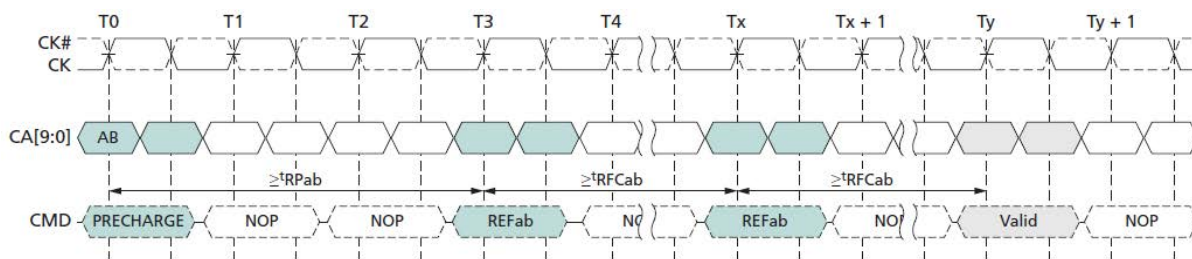
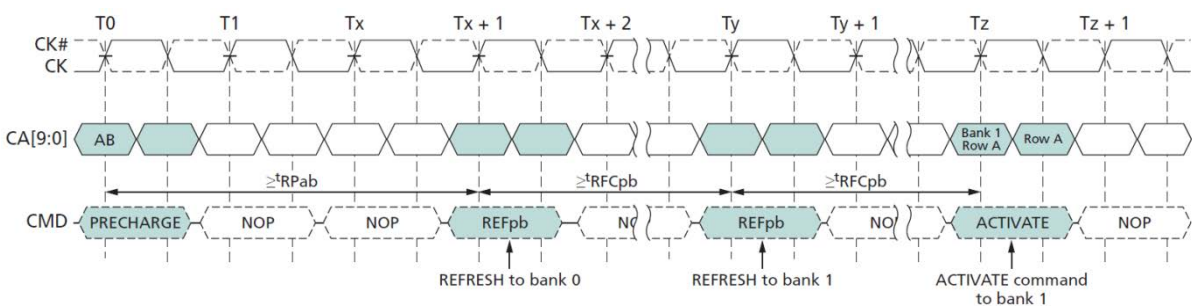
Figure 32: tSRF Definition


Notes : 1. Time in self refresh mode is fully enclosed in the refresh window (t_{REFW}).

2. At self refresh entry.

3. At self refresh exit.

4. Several intervals in self refresh during one t_{REFW} interval. In this example, $t_{SRF} = t_{SRF1} + t_{SRF2}$.

Figure 33 All-Bank REFRESH Operation

Figure 34 Per-Bank REFRESH Operation


Notes : 1. Prior to T_0 , the REFpb bank counter points to bank 0.

2. Operations to banks other than the bank being refreshed are supported during the t_{RFCpb} period.

SELF REFRESH Operation

The SELF REFRESH command can be used to retain data in the array, even if the rest of the system is powered down. When in the self refresh mode, the device retains data without external clocking. The device has a built-in timer to accommodate SELF REFRESH operation. The SELF REFRESH command is executed by taking CKE LOW, CS# LOW, CA0 LOW, CA1 LOW, and CA2 HIGH at the rising edge of the clock.

CKE must be HIGH during the clock cycle preceding a SELF REFRESH command. A NOP command must be driven in the clock cycle following the SELF REFRESH command. After the power-down command is registered, CKE must be held LOW to keep the device in self refresh mode.

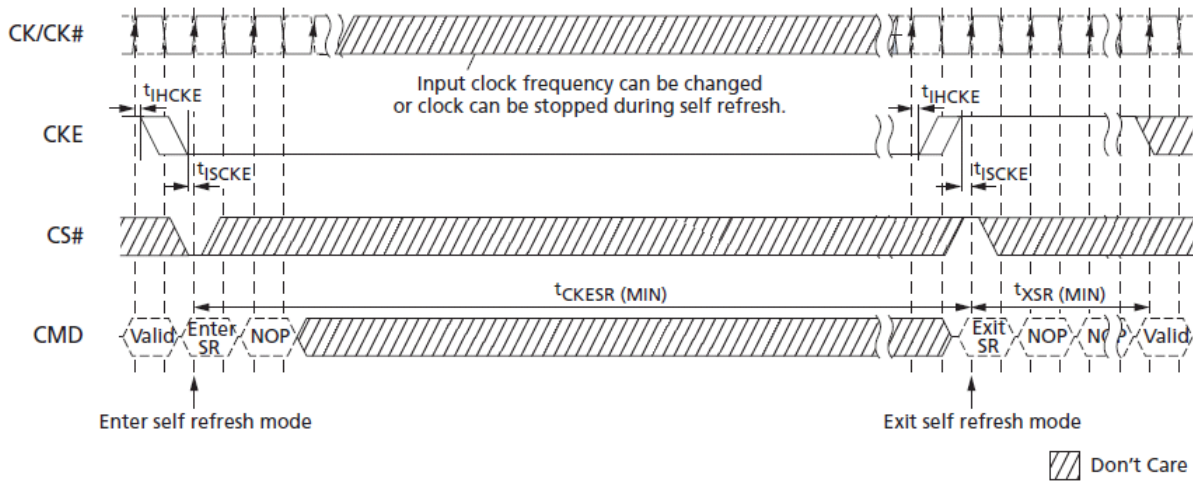
Mobile LPDDR2 devices can operate in self refresh mode in both the standard and extended temperature ranges. These devices also manage self refresh power consumption when the operating temperature changes, resulting in the lowest possible power consumption across the operating temperature range. See Table 59 for details.

After the device has entered self refresh mode, all external signals other than CKE are “Don’t Care.” For proper self refresh operation, power supply pins (VDD1, VDD2, VDDQ, and VDDCA) must be at valid levels. VDDQ can be turned off during self refresh. If VDDQ is turned off, VREFDQ must also be turned off. Prior to exiting self refresh, both VDDQ and VREFDQ must be within their respective minimum/maximum operating ranges (see the Single-Ended AC and DC Input Levels for DQ and DM table). VREFDQ can be at any level between 0 and VDDQ; VREFCA can be at any level between 0 and VDDCA during self refresh.

Before exiting self refresh, VREFDQ and VREFCA must be within specified limits (see AC and DC Logic Input Measurement Levels for Single-Ended Signals (page 78)). After entering self refresh mode, the device initiates at least one all-bank REFRESH command internally during tCKESR. The clock is internally disabled during SELF REFRESH operation to save power. The device must remain in self refresh mode for at least tCKESR. The user can change the external clock frequency or halt the external clock one clock after self refresh entry is registered; however, the clock must be restarted and stable before the device can exit SELF REFRESH operation.

Exiting self refresh requires a series of commands. First, the clock must be stable prior to CKE returning HIGH. After the self refresh exit is registered, a minimum delay, at least equal to the self refresh exit interval (tXSR), must be satisfied before a valid command can be issued to the device. This provides completion time for any internal refresh in progress. For proper operation, CKE must remain HIGH throughout tXSR, except during self refresh re-entry. NOP commands must be registered on each rising clock edge during tXSR.

Using self refresh mode introduces the possibility that an internally timed refresh event could be missed when CKE is driven HIGH for exit from self refresh mode. Upon exiting self refresh, at least one REFRESH command (one all-bank command or eight per-bank commands) must be issued before issuing a subsequent SELF REFRESH command.

Figure 35: SELF REFRESH Operation


- Notes :
1. Input clock frequency can be changed or stopped during self refresh, provided that upon exiting self-refresh, a minimum of two cycles of stable clocks are provided, and the clock frequency is between the minimum and maximum frequencies for the particular speed grade.
 2. The device must be in the all banks idle state prior to entering self refresh mode.
 3. tXSR begins at the rising edge of the clock after CKE is driven HIGH.
 4. A valid command can be issued only after tXSR is satisfied. NOPs must be issued during tXSR.

Partial-Array Self Refresh – Bank Masking

Devices in densities of 64Mb–512Mb are comprised of four banks; densities of 1Gb and higher are comprised of eight banks. Each bank can be configured independently whether or not a SELF REFRESH operation will occur in that bank. One 8-bit mode register (accessible via the MRW command) is assigned to program the bank-masking status of each bank up to eight banks. For bank masking bit assignments, see the MR16 PASR Bank Mask (MA[7:0] = 010h) and MR16 Op-Code Bit Definitions tables.

The mask bit to the bank enables or disables a refresh operation of the entire memory space within the bank.

If a bank is masked using the bank mask register, a REFRESH operation to the entire bank is blocked and bank data retention is not guaranteed in self refresh mode. To enable a REFRESH operation to a bank, the corresponding bank mask bit must be programmed as “unmasked.” When a bank mask bit is unmasked, the array space being refreshed within that bank is determined by the programmed status of the segment mask bits.

Partial-Array Self Refresh – Segment Masking

Programming segment mask bits is similar to programming bank mask bits. For densities 1Gb and higher, eight segments are used for masking (see the MR17 PASR Segment Mask (MA[7:0] = 011h) and MR17 PASR Segment Mask Definitions tables). A mode register is used for programming segment mask bits up to eight bits. For densities less than 1Gb, segment masking is not supported.

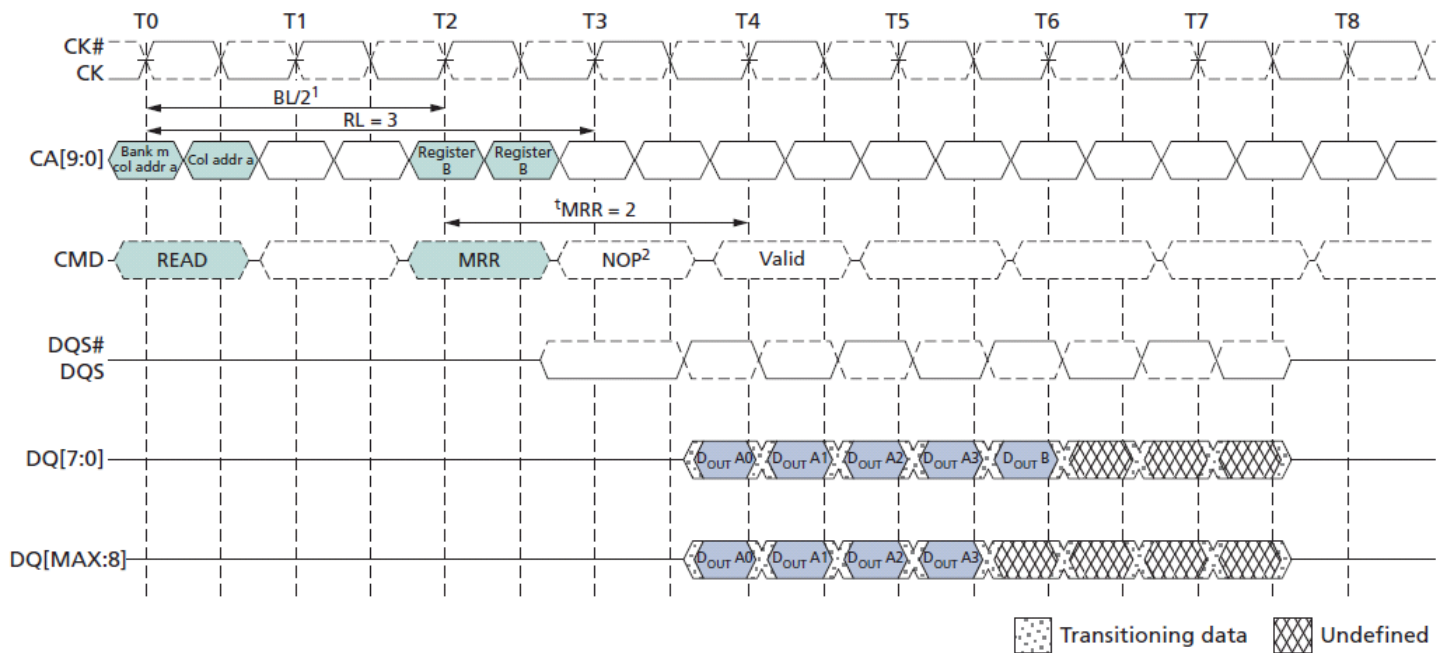
When the mask bit to an address range (represented as a segment) is programmed as “masked,” a REFRESH operation to that segment is blocked. Conversely, when a segment mask bit to an address range is unmasked, refresh to that segment is enabled.

A segment masking scheme can be used in place of or in combination with a bank masking scheme. Each segment mask bit setting is applied across all banks. For segment masking bit assignments, see the tables noted above.

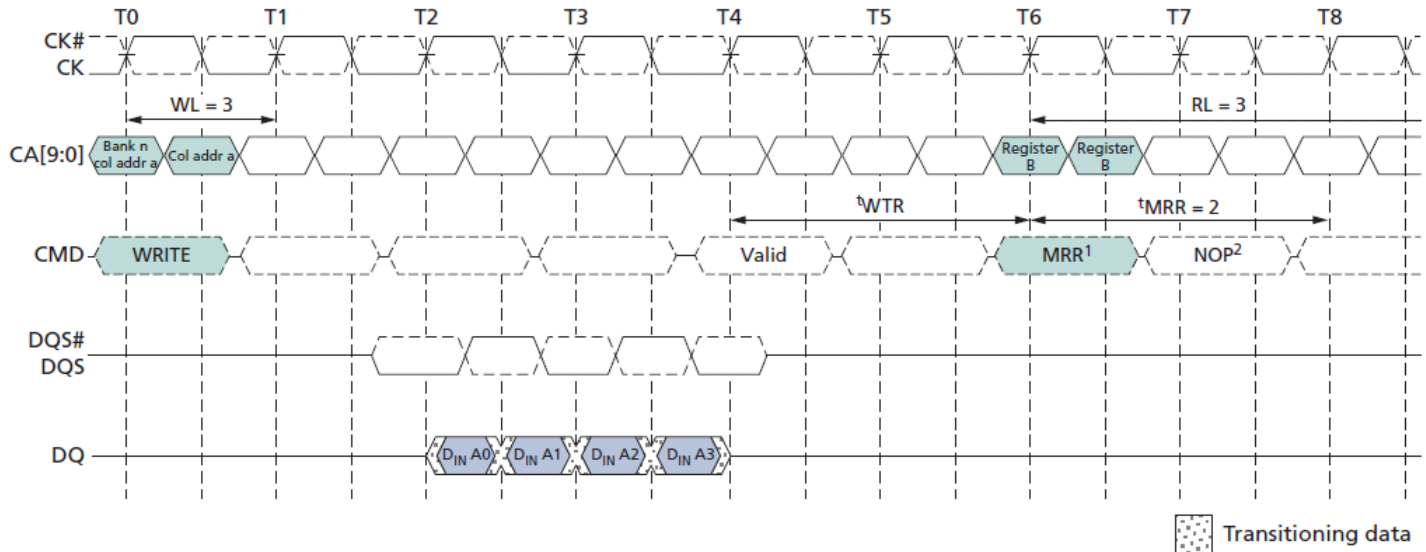
- Notes :
1. MRRs to DQ calibration registers MR32 and MR40 are described in DQ Calibration (page 48).
 2. Only the NOP command is supported during tMRR.
 3. Mode register data is valid only on DQ[7:0] on the first beat. Subsequent beats contain valid but undefined data. DQ[MAX:8] contain valid but undefined data for the duration of the MRR burst.
 4. Minimum MRR to write latency is $RL + RU(tDQSCkmax/tCK) + 4/2 + 1 - WL$ clock cycles.
 5. Minimum MRR to MRW latency is $RL + RU(tDQSCkmax/tCK) + 4/2 + 1$ clock cycles.

READ bursts and WRITE bursts cannot be truncated by MRR. Following a READ command, the MRR command must not be issued before $BL/2$ clock cycles have completed. Following a WRITE command, the MRR command must not be issued before $WL + 1 + BL/2 + RU(tWTR/tCK)$ clock cycles have completed. If a READ or WRITE burst is truncated with a BST command, the effective burst length of the truncated burst should be used for the BL value.

Figure 37: READ to MRR Timing – $RL = 3$, $tMRR = 2$



- Notes :
1. The minimum number of clock cycles from the burst READ command to the MRR command is $BL/2$.
 2. Only the NOP command is supported during tMRR.

Figure 38: Burst WRITE Followed by MRR – RL = 3, WL = 1, BL = 4


- Notes : 1. The minimum number of clock cycles from the burst WRITE command to the MRR command is $[WL+1+BL/2+ RU(tWTR/tCK)]$.
2. Only the NOP command is supported during tMRR.

Temperature Sensor

Mobile LPDDR2 devices feature a temperature sensor whose status can be read from MR4.

This sensor can be used to determine an appropriate refresh rate, determine whether AC timing derating is required in the extended temperature range, and/or monitor the operating temperature. Either the temperature sensor or the device operating temperature can be used to determine whether operating temperature requirements are being met (see Operating Temperature Range table).

Temperature sensor data can be read from MR4 using the mode register read protocol. Upon exiting self-refresh or power-down, the device temperature status bits will be no older than tTSI.

When using the temperature sensor, the actual device case temperature may be higher than the operating temperature specification that applies for the standard or extended temperature ranges (see table noted above).

For example, TCASE could be above 85°C when MR4[2:0] equals 011b. To ensure proper operation using the temperature sensor, applications must accommodate the parameters in the temperature sensor definitions table.

Table 27: Temperature Sensor Definitions and Operating Conditions

| Parameter | Description | Symbol | Min/Max | Value | Unit |
|-----------------------------|--|--------------|---------|------------------|------|
| System Temperature Gradient | Maximum temperature gradient experienced by the memory device at the temperature of interest over a range of 2°C | TempGradient | MAX | System dependent | °C/s |
| MR4 READ interval | Time period between MR4 READs from the System | ReadInterval | MAX | System dependent | ms |
| Temperature Sensor interval | Maximum delay between internal updates of MR4 | tTSI | MAX | 32 | ms |
| System response delay | Maximum response time from an MR4 READ to the system response | SysRespDelay | MAX | System dependent | ms |
| Device temperature margin | Margin above maximum temperature to support controller response | TempMargin | MAX | 2 | °C |

Mobile LPDDR2 devices accommodate the temperature margin between the point at which the device temperature enters the extended temperature range and the point at which the controller reconfigures the system accordingly. To determine the required MR4 polling frequency, the system must use the maximum TempGradient and the maximum response time of the system according to the following equation:

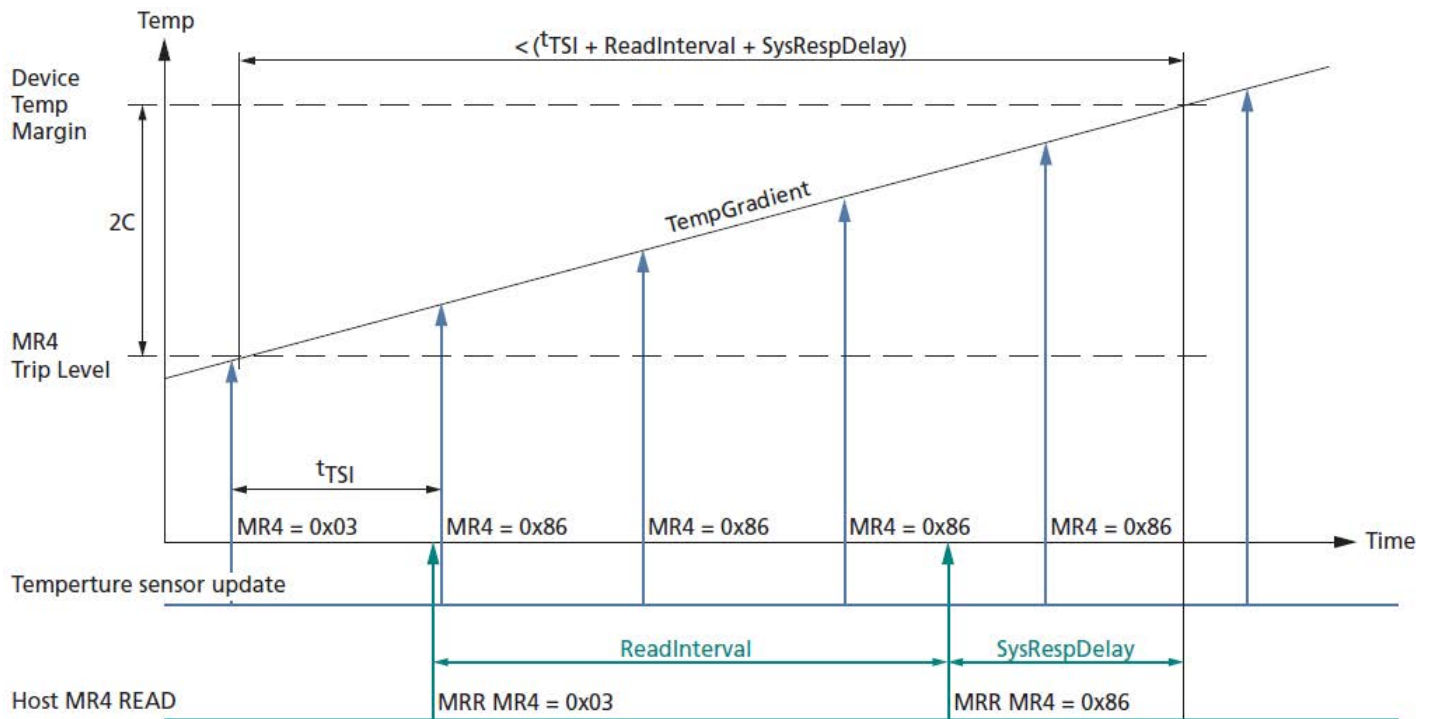
$$\text{TempGradient} \times (\text{ReadInterval} + t_{\text{TSI}} + \text{SysRespDelay}) \leq 2^{\circ}\text{C}$$

For example, if TempGradient is 10°C/s and the SysRespDelay is 1ms:

$$10^{\circ}\text{C/s} \times (\text{ReadInterval} + 32\text{ms} + 1\text{ms}) \leq 2^{\circ}\text{C}$$

In this case, ReadInterval must not exceed 167ms.

Figure 39: Temperature Sensor Timing

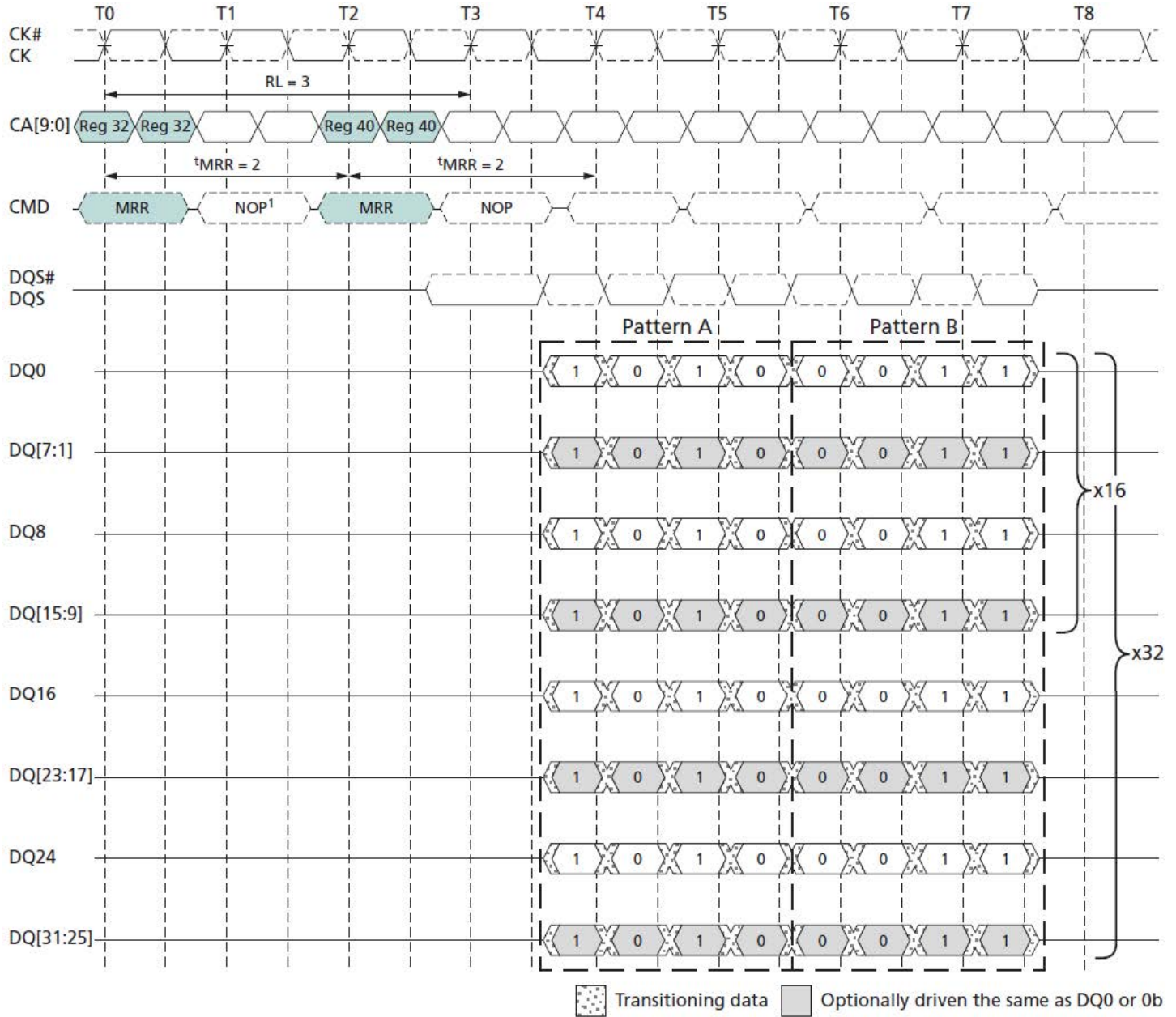


DQ Calibration

Mobile LPDDR2 devices feature a DQ calibration function that outputs one of two predefined system timing calibration patterns.

For x16 devices, pattern A (MRR to MRR32), and pattern B (MRR to MRR40), will return the specified pattern on DQ0 and DQ8; x32 devices return the specified pattern on DQ0, DQ8, DQ16, and DQ24.

For x16 devices, DQ[7:1] and DQ[15:9] drive the same information as DQ0 during the MRR burst. For x32 devices, DQ[7:1], DQ[15:9], DQ[23:17], and DQ[31:25] drive the same information as DQ0 during the MRR burst. MRR DQ calibration commands can occur only in the idle state.

Figure 40: MR32 and MR40 DQ Calibration Timing – RL = 3, tMRR = 2


Note : 1. Only the NOP command is supported during tMRR.

Table28 : Data Calibration Pattern Description

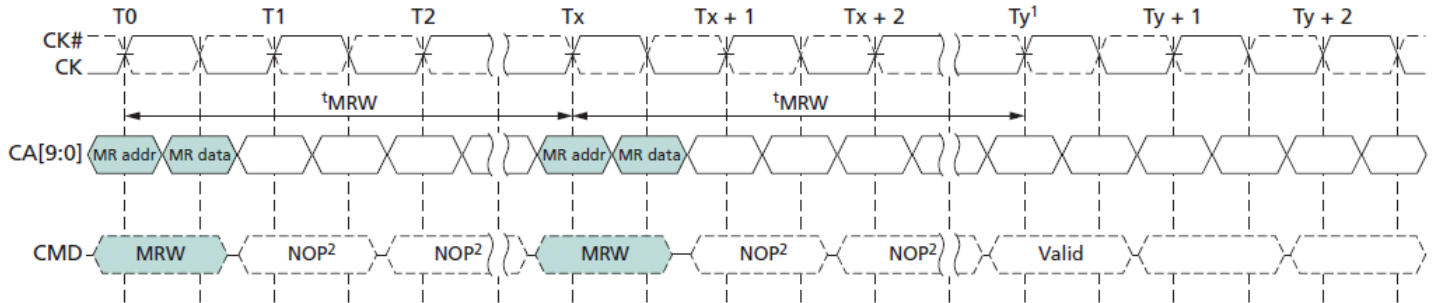
| Pattern | MR# | Bit Time 0 | Bit Time 1 | Bit Time 2 | Bit Time 3 | Description |
|-----------|------|------------|------------|------------|------------|---|
| Pattern A | MR32 | 1 | 0 | 1 | 0 | Reads to MR32 return DQ calibration pattern A |
| Pattern B | MR40 | 0 | 0 | 1 | 1 | Reads to MR40 return DQ calibration pattern B |

MODE REGISTER WRITE Command

The MODE REGISTERWRITE (MRW) command is used to write configuration data to the mode registers.

The MRW command is initiated with CS# LOW, CA0 LOW, CA1 LOW, CA2 LOW, and CA3 LOW at the rising edge of the clock. The mode register is selected by CA1f–CA0f, CA9r–CA4r. The data to be written to the mode register is contained in CA9f–CA2f. The MRW command period is defined by tMRW. MRWs to read-only registers have no impact on the functionality of the device. MRW can only be issued when all banks are in the idle precharge state. One method of ensuring that the banks are in this state is to issue a PRECHARGE ALL command.

Figure 41: MODE REGISTER WRITE Timing – RL = 3, tMRW = 5



Notes : 1. At time Ty, the device is in the idle state.

2. Only the NOP command is supported during tMRW.

Table29 : Truth Table for MRR and MRW

| Current State | Command | Intermediate State | Next State |
|----------------|-------------|---------------------------------------|----------------|
| All banks idle | MRR | Reading mode register, all banks idle | All banks idle |
| | MRW | Writing mode register, all banks idle | All banks idle |
| | MRW (RESET) | Resetting, device auto initialization | All banks idle |
| Bank(s) active | MRR | Reading mode register, bank(s) idle | Bank(s) active |
| | MRW | Not allowed | Not allowed |
| | MRW (RESET) | Not allowed | Not allowed |

MRW RESET Command

The MRW RESET command brings the device to the device auto initialization (resetting) state in the power-on initialization sequence (see 2. RESET Command under Power-Up (page 7)).

The MRW RESET command can be issued from the idle state. This command resets all mode registers to their default values.

Only the NOP command is supported during tINIT4.

After MRW RESET, boot timings must be observed until the device initialization sequence is complete and the device is in the idle state. Array data is undefined after the MRW RESET command has completed. For MRW RESET timing, see Figure 1.

MRW ZQ Calibration Commands

The MRW command is used to initiate a ZQ calibration command that calibrates output driver impedance across process, temperature, and voltage. LPDDR2-S4 devices support ZQ calibration. To achieve tighter tolerances, proper ZQ calibration must be performed. There are four ZQ calibration commands and related timings: tZQINIT, tZQRESET, tZQCL, and tZQCS. tZQINIT is used for initialization calibration; tZQRESET is used for resetting ZQ to the default output impedance; tZQCL is used for long calibration(s); and tZQCS is used for short calibration(s). See the MR10 Calibration (MA[7:0] = 0Ah) table for ZQ calibration command code definitions.

ZQINIT must be performed for LPDDR2 devices. ZQINIT provides an output impedance accuracy of ±15%.

After initialization, the ZQ calibration long (ZQCL) can be used to recalibrate the system to an output impedance accuracy of ±15%.

A ZQ calibration short (ZQCS) can be used periodically to compensate for temperature and voltage drift in the system.

ZQRESET resets the output impedance calibration to a default accuracy of ±30% across process, voltage, and temperature.

This command is used to ensure output impedance accuracy to ±30% when ZQCS and ZQCL commands are not used.

One ZQCS command can effectively correct at least 1.5% (ZQ correction) of output impedance errors within tZQCS for all speed bins, assuming the maximum sensitivities specified in Table 68 and Table 69 are met. The appropriate interval between ZQCS commands can be determined using these tables and system-specific parameters.

Mobile LPDDR2 devices are subject to temperature drift rate (Tdriftrate) and voltage drift rate (Vdriftrate) in various applications.

To accommodate drift rates and calculate the necessary interval between ZQCS commands, apply the following formula:

$$\frac{ZQ_{\text{correction}}}{(T_{\text{sens}} \times T_{\text{driftrate}}) + (V_{\text{sens}} \times V_{\text{driftrate}})}$$

Where Tsens = MAX (dRONdT) and Vsens = MAX (dRONdV) define temperature and voltage sensitivities.

For example, if Tsens = 0.75%/°C, Vsens = 0.20%/mV, Tdriftrate = 1°C/sec, and Vdriftrate = 15 mV/sec, then the interval between ZQCS commands is calculated as:

$$\frac{1.5}{(0.75 \times 1) + (0.20 \times 15)} = 0.4\text{s}$$

A ZQ calibration command can only be issued when the device is in the idle state with all banks precharged.

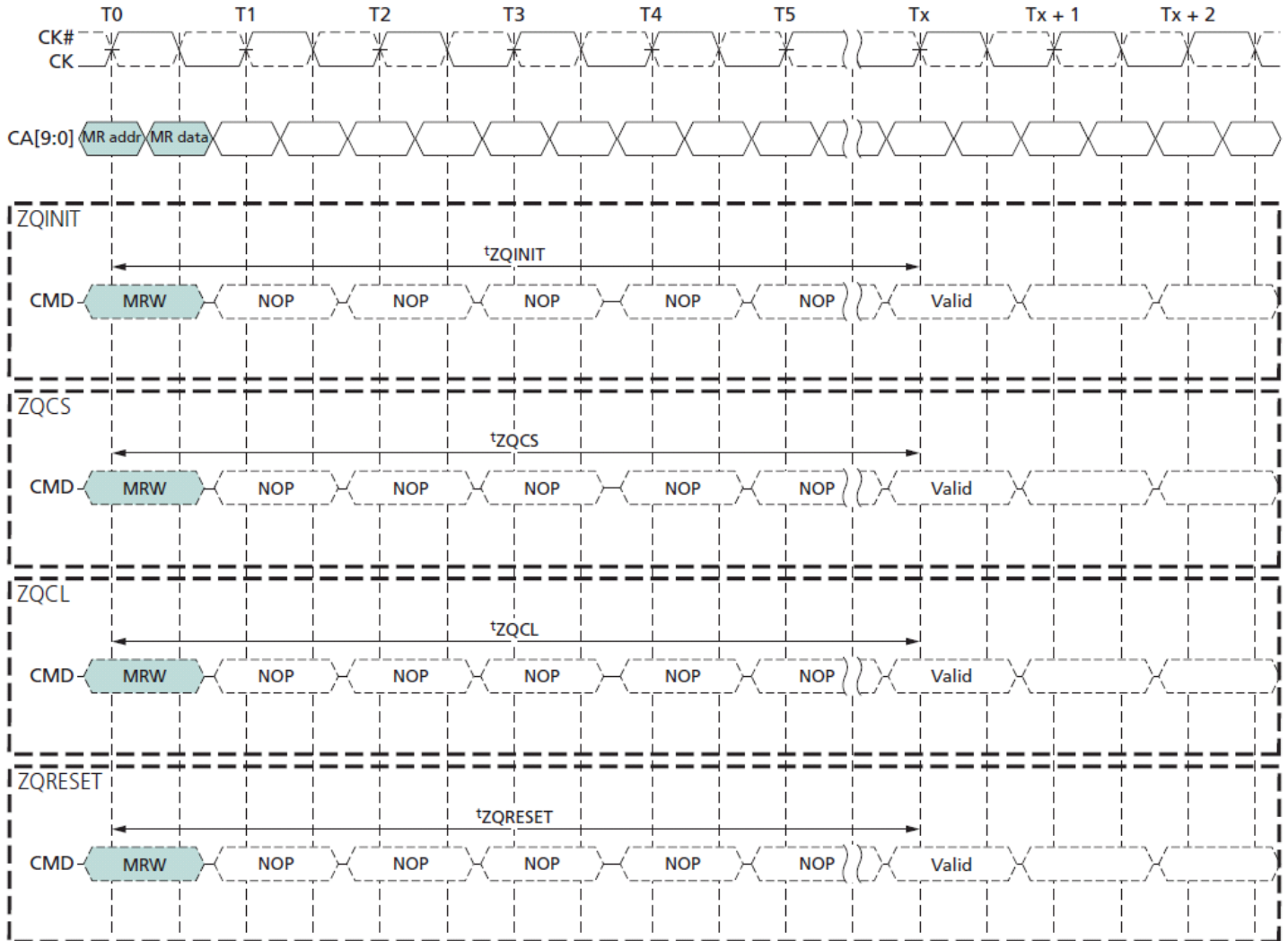
No other activities can be performed on the data bus during calibration periods (tZQINIT, tZQCL, or tZQCS).

The quiet time on the data bus helps to accurately calibrate output impedance.

There is no required quiet time after the ZQRESET command. If multiple devices share a single ZQ resistor, only one device can be calibrating at any given time. After calibration is complete, the ZQ ball circuitry is disabled to reduce power consumption.

In systems sharing a ZQ resistor between devices, the controller must prevent tZQINIT, tZQCS, and tZQCL overlap between the devices. ZQRESET overlap is acceptable. If the ZQ resistor is absent from the system, ZQ must be connected to VDDCA.

In this situation, the device must ignore ZQ calibration commands and the device will use the default calibration settings.

Figure 42: ZQ Timings


- Notes :
1. Only the NOP command is supported during ZQ calibrations.
 2. CKE must be registered HIGH continuously during the calibration period.
 3. All devices connected to the DQ bus should be High-Z during the calibration process.

ZQ External Resistor Value, Tolerance, and Capacitive Loading

To use the ZQ calibration function, a 240 ohm ($\pm 1\%$ tolerance) external resistor must be connected between the ZQ pin and ground. A single resistor can be used for each device or one resistor can be shared between multiple devices if the ZQ calibration timings for each device do not overlap. The total capacitive loading on the ZQ pin must be limited (see the Input/Output Capacitance table).

Power-Down

Power-down is entered synchronously when CKE is registered LOW and CS# is HIGH at the rising edge of clock. A NOP command must be driven in the clock cycle following power-down entry. CKE must not go LOW while MRR, MRW, READ, or WRITE operations are in progress. CKE can go LOW while any other operations such as ACTIVATE, PRECHARGE, auto precharge, or REFRESH are in progress, but the power-down IDD specification will not be applied until such operations are complete.

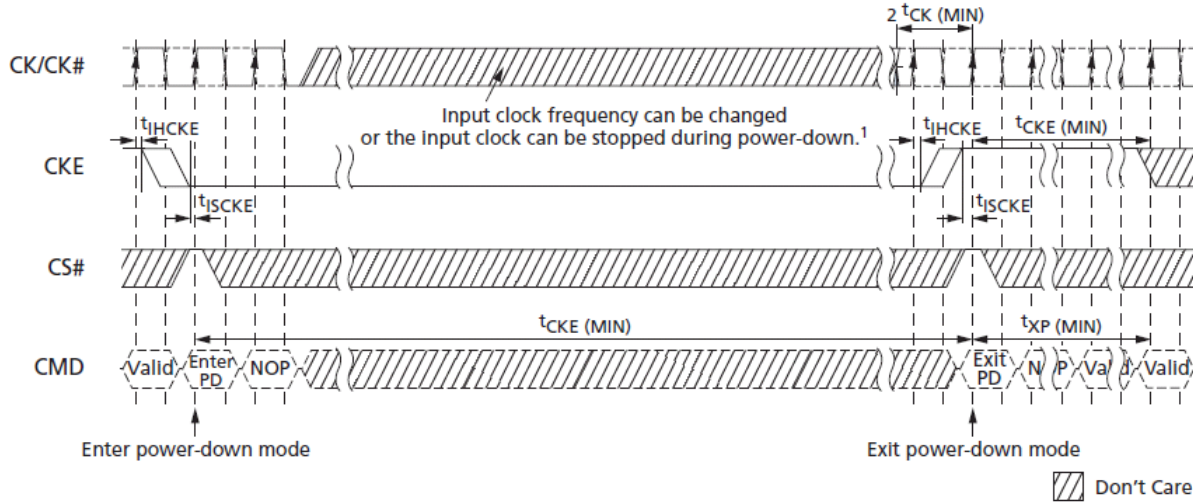
If power-down occurs when all banks are idle, this mode is referred to as idle power-down;

if power-down occurs when there is a row active in any bank, this mode is referred to as active power-down.

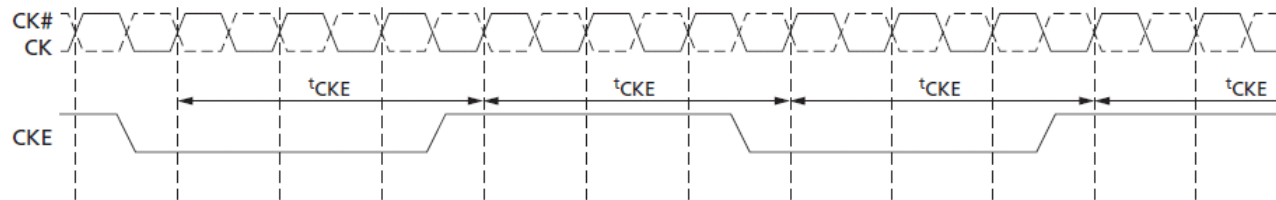
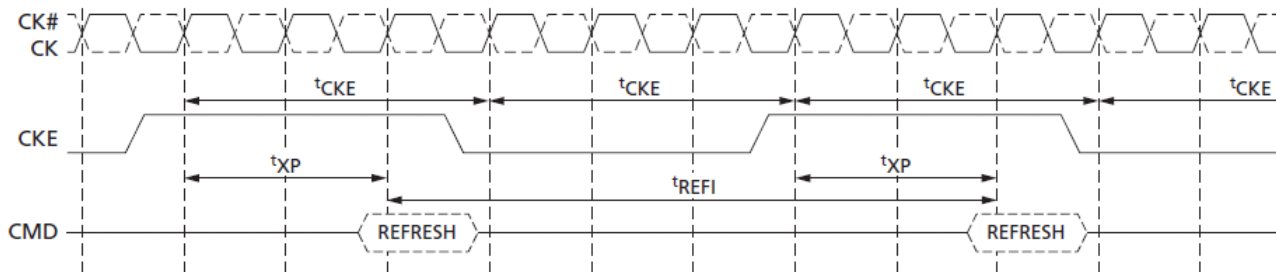
Entering power-down deactivates the input and output buffers, excluding CK, CK#, and CKE. In power-down mode, CKE must be held LOW; all other input signals are "Don't Care." CKE LOW must be maintained until tCKE is satisfied. VREFCA must be Maintained at a valid level during power-down. VDDQ can be turned off during power-down. If VDDQ is turned off, VREFDQ must also be turned off. Prior to exiting power-down, both VDDQ and VREFDQ must be within their respective minimum/maximum operating ranges (see AC and DC Operating Conditions).

No refresh operations are performed in power-down mode. The maximum duration in power-down mode is only limited by the refresh requirements outlined in REFRESH Command. The power-down state is exited when CKE is registered HIGH.

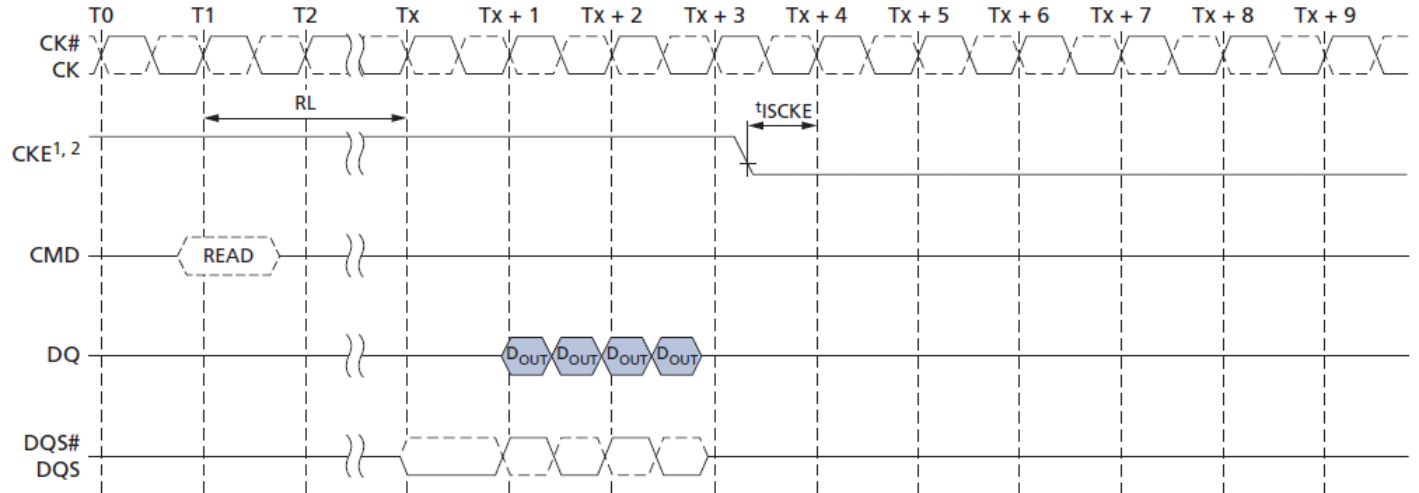
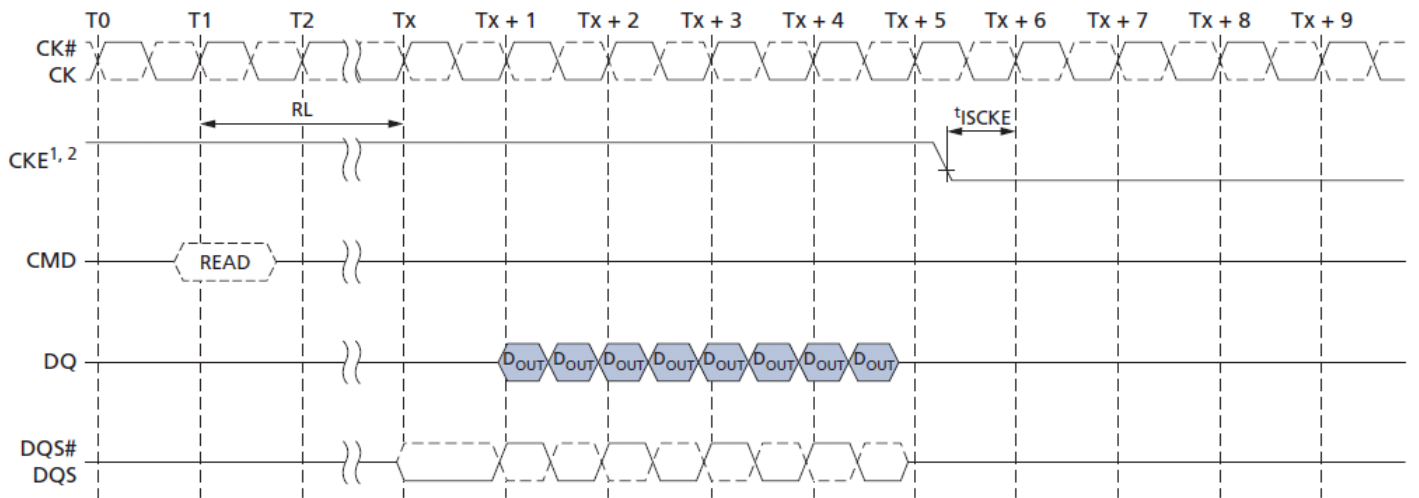
The controller must drive CS# HIGH in conjunction with CKE HIGH when exiting the power-down state. CKE HIGH must be maintained until tCKE is satisfied. A valid, executable command can be applied with power-down exit latency tXP after CKE goes HIGH. Power-down exit latency is defined in the ACTiming section.

Figure 43: Power-Down Entry and Exit Timing


Note : 1. Input clock frequency can be changed or the input clock stopped during power-down, provided that the clock frequency is between the minimum and maximum specified frequencies for the speed grade in use, and that prior to power-down exit, a minimum of two stable clocks complete.

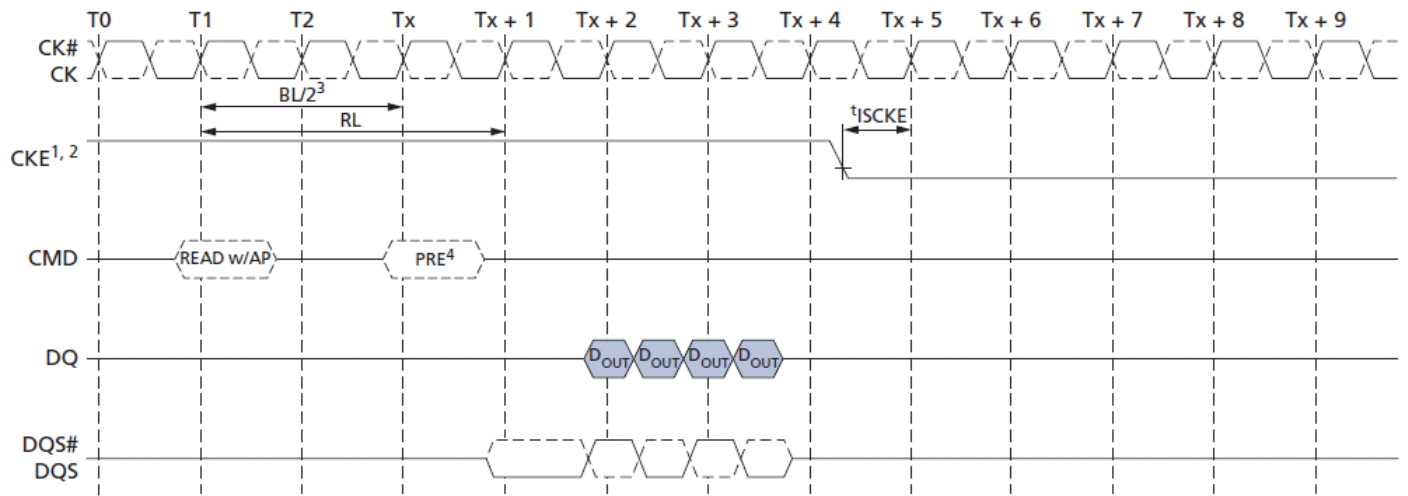
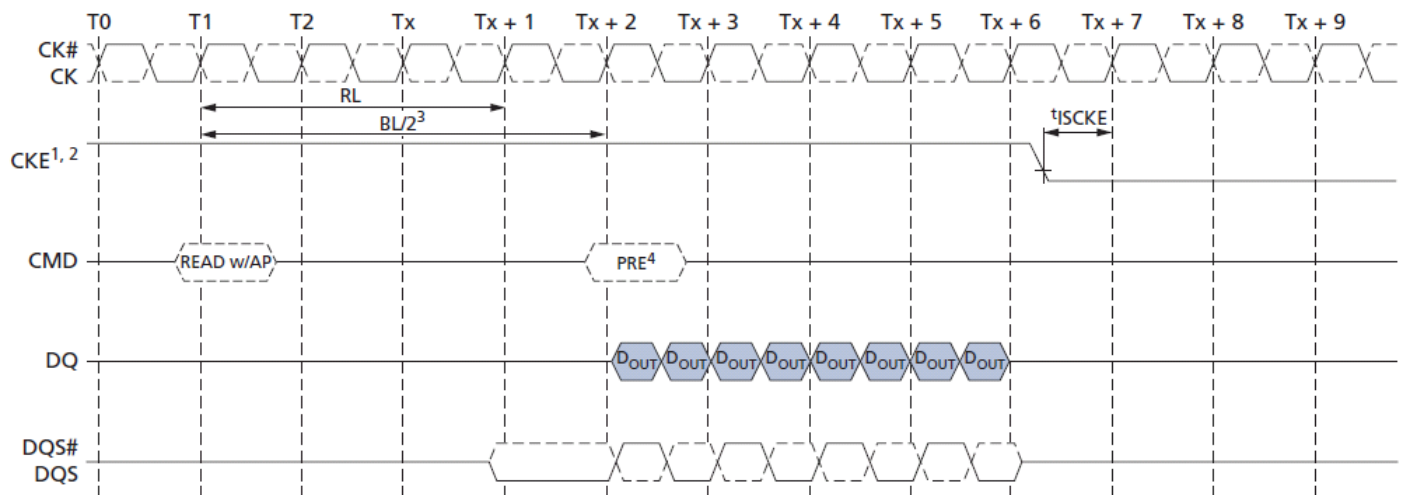
Figure 44: CKE Intensive Environment

Figure 45: REFRESH-to-REFRESH Timing in CKE Intensive Environments


Note : 1. The pattern shown can repeat over an extended period of time. With this pattern, all AC and DC timing and voltage specifications with temperature and voltage drift are ensured.

Figure 46: READ to Power-Down Entry
BL = 4

BL = 8


Notes : 1. CKE must be held HIGH until the end of the burst operation.

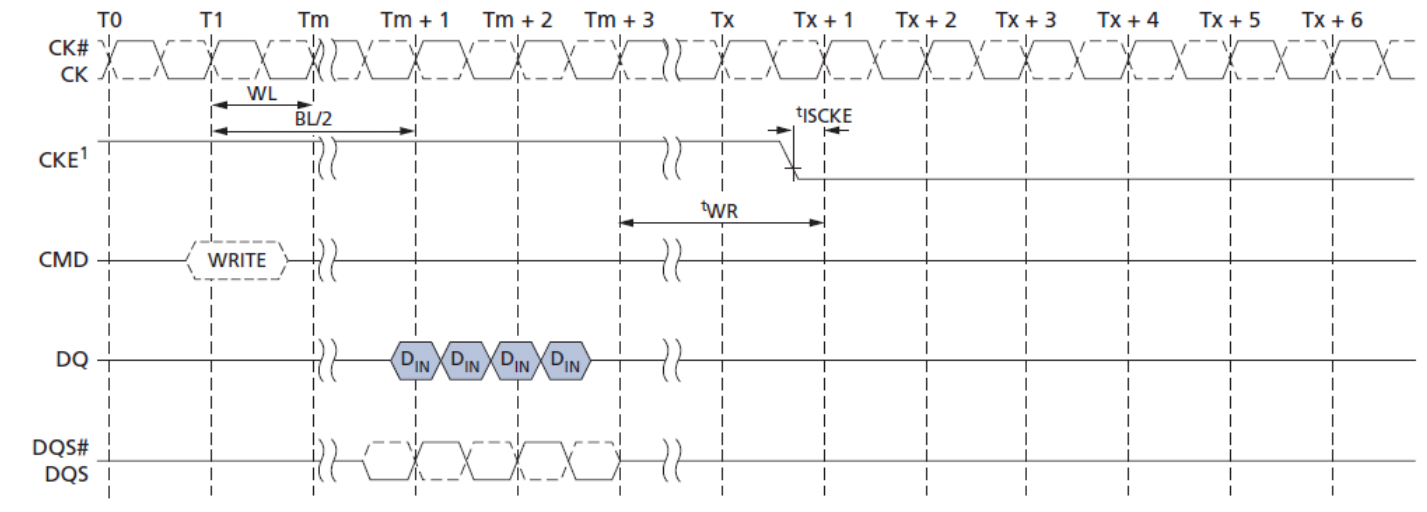
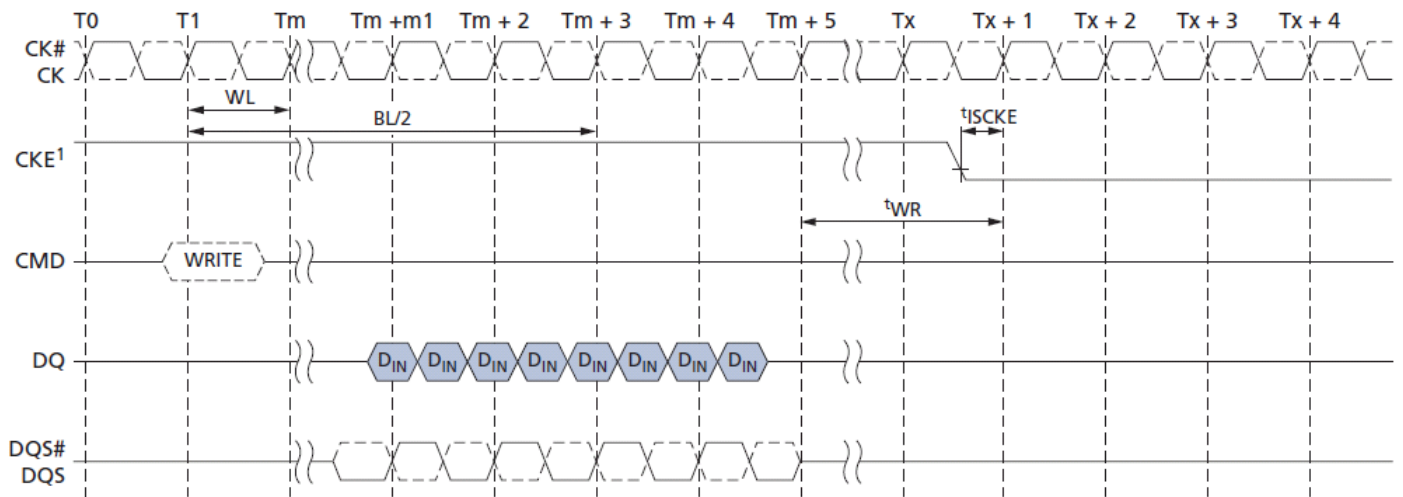
2. CKE can be registered LOW at $(RL + RU(t_{DQSK}(MAX)/t_{CK}) + BL/2 + 1)$ clock cycles after the clock on which the READ command is registered.

Figure 47: READ with Auto Precharge to Power-Down Entry
BL = 4

BL = 8

Notes : 1. CKE must be held HIGH until the end of the burst operation.

 2. CKE can be registered LOW at $(RL + RU(t_{DQ\text{SCK}}/CK) + BL/2 + 1)$ clock cycles after the clock on which the READ command is registered.

 3. $BL/2$ with $t_{RTP} = 7.5\text{ns}$ and $t_{RAS}(\text{MIN})$ is satisfied.

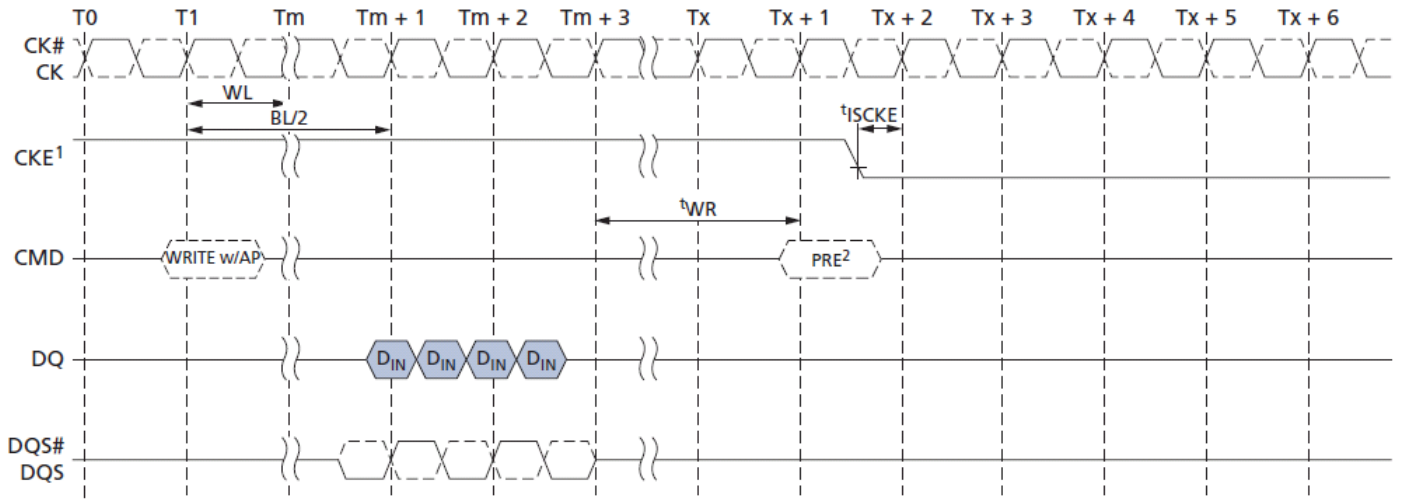
4. Start internal PRECHARGE.

Figure 48: WRITE to Power-Down Entry
BL = 4

BL = 8


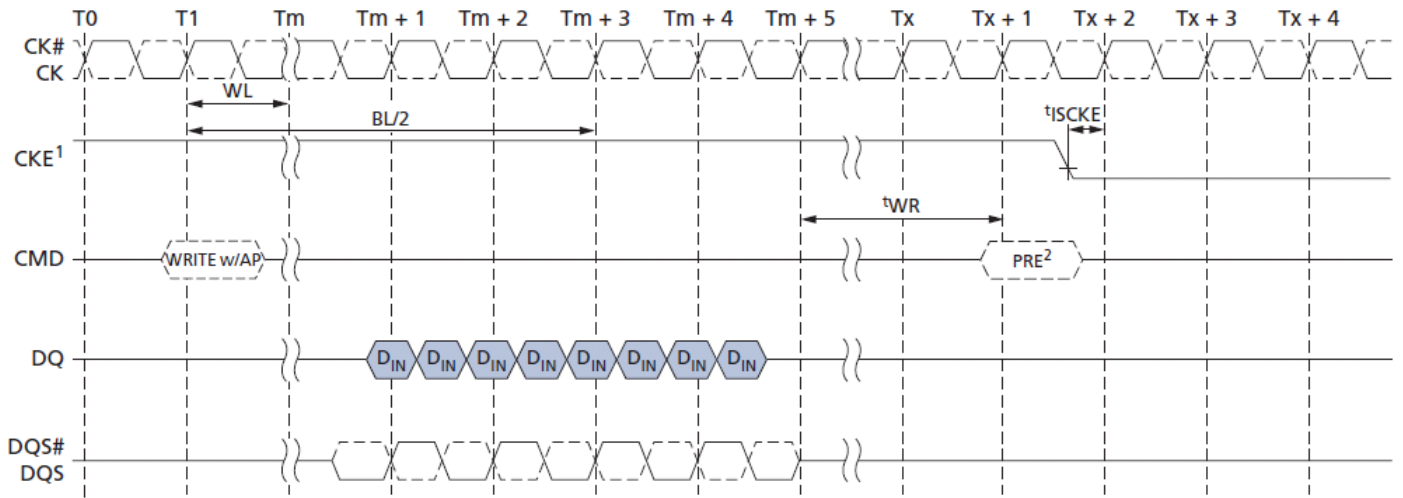
Note : 1. CKE can be registered LOW at $(WL + 1 + BL/2 + RU(t_{WR}/CK))$ clock cycles after the clock on which the WRITE command is registered.

Figure 49: WRITE with Auto Precharge to Power-Down Entry

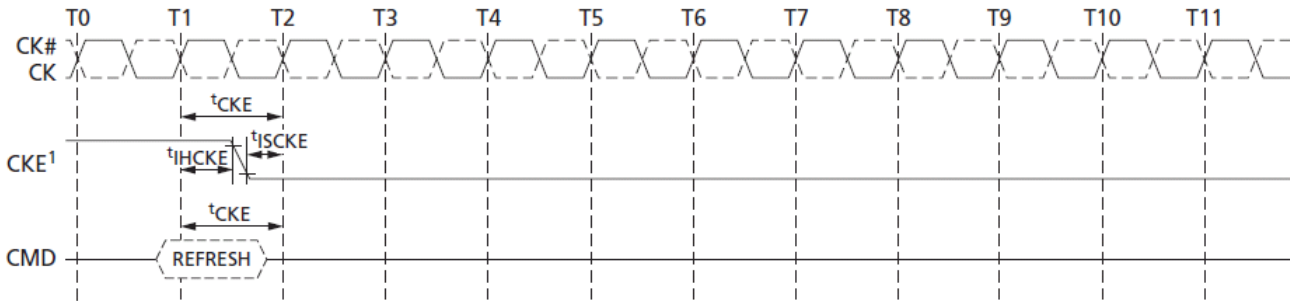
BL = 4



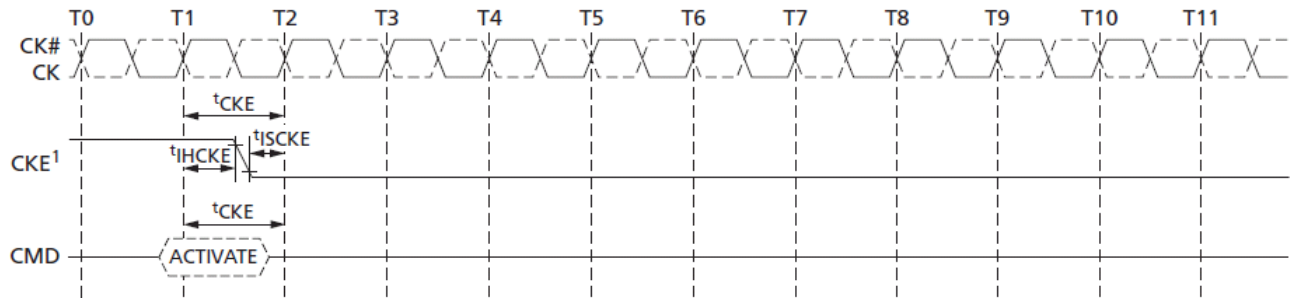
BL = 8



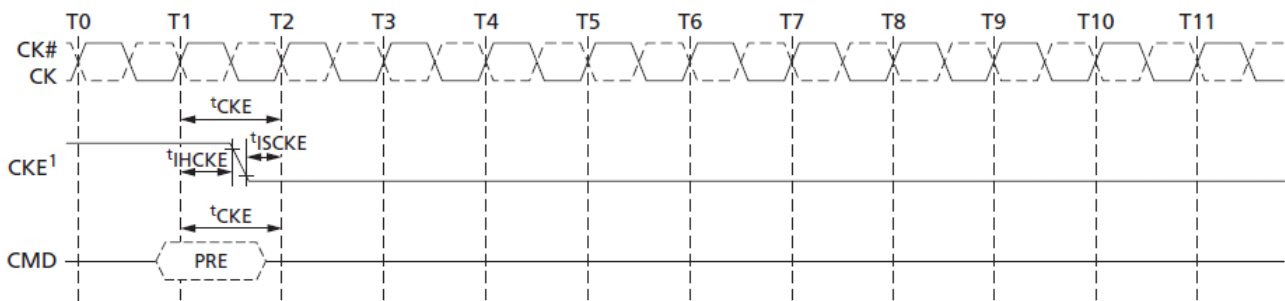
- Notes : 1. CKE can be registered LOW at $(WL + 1 + BL/2 + RU(t_{WR}/t_{CK} + 1))$ clock cycles after the WRITE command is registered.
 2. Start internal PRECHARGE.

Figure 50: REFRESH Command to Power-Down Entry


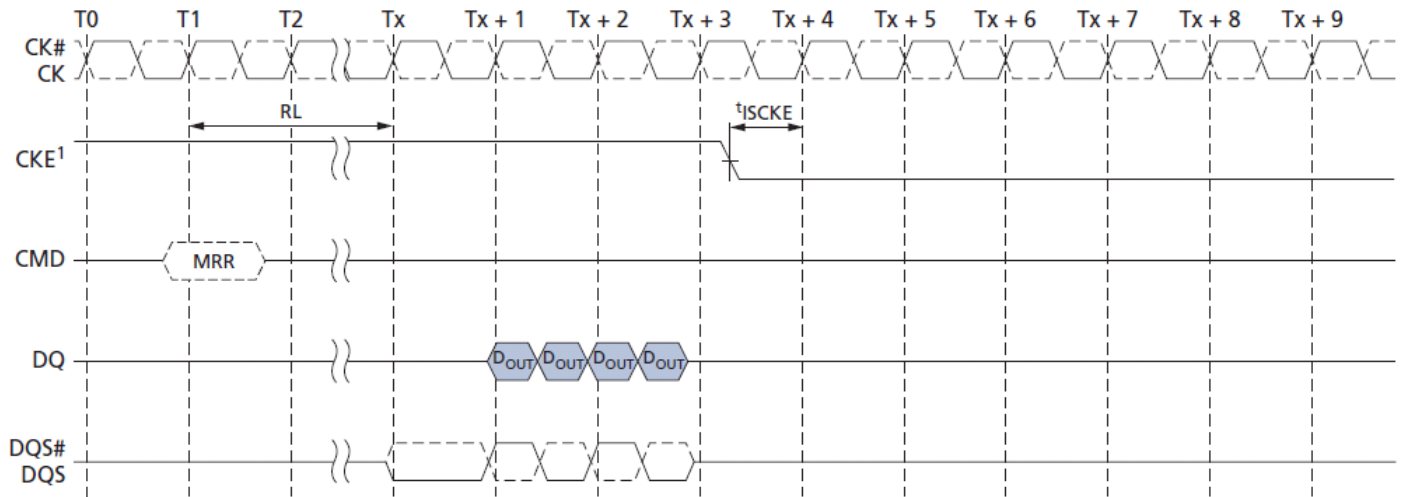
Note : 1. CKE can go LOW t_{IHCKE} after the clock on which the REFRESH command is registered.

Figure 51: ACTIVATE Command to Power-Down Entry


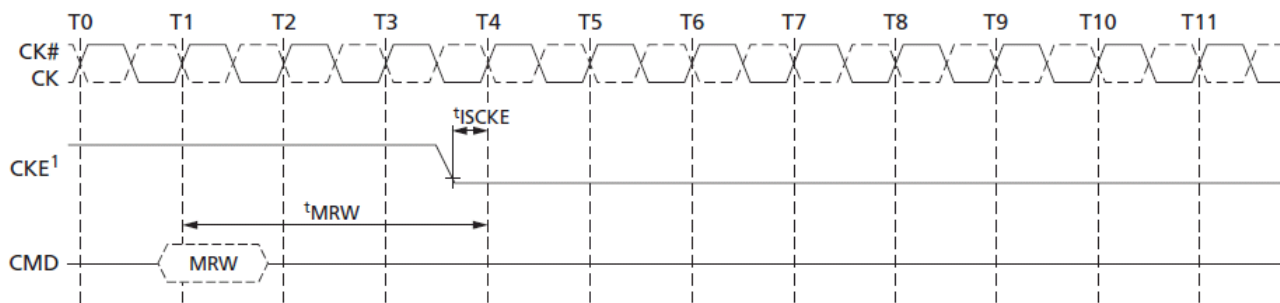
Note : 1. CKE can go LOW at t_{IHCKE} after the clock on which the ACTIVATE command is registered.

Figure 52: PRECHARGE Command to Power-Down Entry


Note : 1. CKE can go LOW t_{IHCKE} after the clock on which the PRECHARGE command is registered.

Figure 53: MRR Command to Power-Down Entry


Note : 1. CKE can be registered LOW at $(RL + RU(tDQSCK/tCK) + BL/2 + 1)$ clock cycles after the clock on which the MRR command is registered.

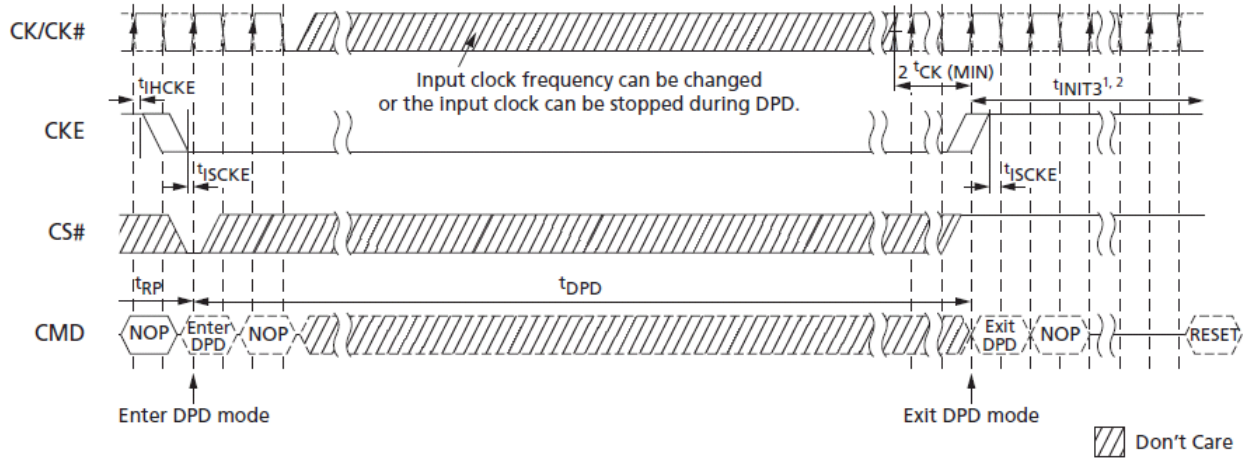
Figure 54: MRW Command to Power-Down Entry


Note : 1. CKE can be registered LOW $tMRW$ after the clock on which the MRW command is registered.

Deep Power-Down

Deep power-down (DPD) is entered when CKE is registered LOW with CS# LOW, CA0 HIGH, CA1 HIGH, and CA2 LOW at the rising edge of the clock. The NOP command must be driven in the clock cycle following power-down entry. CKE must not go LOW while MRR or MRW operations are in progress. CKE can go LOW while other operations such as ACTIVATE, auto precharge, PRECHARGE, or REFRESH are in progress, however, deep power-down IDD specifications will not be applied until those operations complete. The contents of the array will be lost upon entering DPD mode.

In DPD mode, all input buffers except CKE, all output buffers, and the power supply to internal circuitry are disabled within the device. VREFDQ can be at any level between 0 and VDDQ, and VREFCA can be at any level between 0 and VDDCA during DPD. All power supplies (including VREF) must be within the specified limits prior to exiting DPD (see AC and DC Operating Conditions). To exit DPD, CKE must be HIGH, $tISCKE$ must be complete, and the clock must be stable. To resume operation, the device must be fully reinitialized using the power-up initialization sequence.

Figure 55: Deep Power-Down Entry and Exit Timing


Notes : 1. The initialization sequence can start at any time after $T_x + 1$.

2. t_{INIT3} and $T_x + 1$ refer to timings in the initialization sequence. For details, see Mode Register Definition.

Input Clock Frequency Changes and Stop Events

Input Clock Frequency Changes and Clock Stop with CKE LOW

During CKE LOW, Mobile LPDDR2 devices support input clock frequency changes and clock stop under the following conditions:

- Refresh requirements are met
- Only REFab or REFpb commands can be in process
- Any ACTIVATE or PRECHARGE commands have completed prior to changing the frequency
- Related timing conditions, t_{RCD} and t_{RP} , have been met prior to changing the frequency
- The initial clock frequency must be maintained for a minimum of two clock cycles after CKE goes LOW
- The clock satisfies $t_{CH(abs)}$ and $t_{CL(abs)}$ for a minimum of two clock cycles prior to CKE going HIGH

For input clock frequency changes, $t_{CK(MIN)}$ and $t_{CK(MAX)}$ must be met for each clock cycle.

After the input clock frequency is changed and CKE is held HIGH, additional MRW commands may be required to set the WR, RL, etc.

These settings may require adjustment to meet minimum timing requirements at the target clock frequency.

For clock stop, CK is held LOW and CK# is held HIGH.

Input Clock Frequency Changes and Clock Stop with CKE HIGH

During CKE HIGH, LPDDR2 devices support input clock frequency changes and clock stop under the following conditions:

- REFRESH requirements are met.
- Any ACTIVATE, READ, WRITE, PRECHARGE, MRW, or MRR commands must have completed, including any associated data bursts, prior to changing the frequency.
- Related timing conditions, tRCD, tWR, tWRA, tRP, tMRW, and tMRR, etc., are met
- CS# must be held HIGH
- Only REFab or REFpb commands can be in process

The device is ready for normal operation after the clock satisfies tCH(abs) and tCL(abs) for a minimum of $2 \times tCK + tXP$.

For input clock frequency changes, tCK(MIN) and tCK(MAX) must be met for each clock cycle.

After the input clock frequency is changed, additional MRW commands may be required to set the WR, RL, etc. These settings may

require adjustment to meet minimum timing requirements at the target clock frequency.

For clock stop, CK is held LOW and CK# is held HIGH.

NO OPERATION Command

The NO OPERATION (NOP) command prevents the device from registering any unwanted commands issued between operations. A NOP command can only be issued at clock cycle N when the CKE level is constant for clock cycle N-1 and clock cycle N. The NOP command has two possible encodings: CS# HIGH at the clock rising edge N; and CS# LOW with CA0, CA1, CA2 HIGH at the clock rising edge N.

The NOP command will not terminate a previous operation that is still in process, such as a READ burst or WRITE burst cycle.

Simplified Bus Interface State Diagram

The state diagram provides a simplified illustration of the bus interface, supported state transitions, and the commands that control them. For a complete description of device behavior, use the information provided in the state diagram with the truth tables and timing specifications. The truth tables describe device behavior and applicable restrictions when considering the actual state of all banks.

Truth Tables



































Truth tables provide complementary information to the state diagram. They also clarify device behavior and applicable restrictions when

considering the actual state of the banks. Unspecified operations and timings are illegal. To ensure proper operation after an illegal event, the

device must be powered down and then restarted using the specified initialization sequence before normal operation can continue.

Table30 : Command Truth table

Notes 1–11 apply to all parameters conditions

| Command | Command Pins | | | CA Pins | | | | | | | | | | CK Edge |
|-------------------------------------|--------------|-------|-----|---------|-----|-----|-----|-----|-----|-----|-----|-----|---|---|
| | CKE | | CS# | CA0 | CA1 | CA2 | CA3 | CA4 | CA5 | CA6 | CA7 | CA8 | CA9 | |
| | CK(n-1) | CK(n) | | | | | | | | | | | | |
| MRW | H | H | L | L | L | L | L | MA0 | MA1 | MA2 | MA3 | MA4 | MA5 |  |
| | H | H | X | MA6 | MA7 | OP0 | OP1 | OP2 | OP3 | OP4 | OP5 | OP6 | OP7 |  |
| MRR | H | H | L | L | L | L | H | MA0 | MA1 | MA2 | MA3 | MA4 | MA5 |  |
| | H | H | X | MA6 | MA7 | X | | | | | | |  | |
| REFRESH (per bank) | H | H | L | L | L | H | L | X | | | | | |  |
| | H | H | X | X | | | | | | | | | |  |
| REFRESH (all banks) | H | H | L | L | L | H | H | X | | | | | |  |
| | H | H | X | X | | | | | | | | | |  |
| Enter self refresh | H | L | L | L | L | H | X | | | | | |  | |
| | X | L | X | X | | | | | | | | | |  |
| ACTIVATE (bank) | H | H | L | L | H | R8 | R9 | R10 | R11 | R12 | BA0 | BA1 | BA2 |  |
| | H | H | X | R0 | R1 | R2 | R3 | R4 | R5 | R6 | R7 | R13 | R14 |  |
| WRITE(bank) | H | H | L | H | L | L | RFU | RFU | C1 | C2 | BA0 | BA1 | BA2 |  |
| | H | H | X | AP | C3 | C4 | C5 | C6 | C7 | C8 | C9 | C10 | C11 |  |
| READ bank) | H | H | L | H | L | H | RFU | RFU | C1 | C2 | BA0 | BA1 | BA2 |  |
| | H | H | X | AP | C3 | C4 | C5 | C6 | C7 | C8 | C9 | C10 | C11 |  |
| PRECHARGE (bank) | H | H | L | H | H | L | H | AB | X | X | BA0 | BA1 | BA2 |  |
| | H | H | X | X | | | | | | | | | |  |
| BST | H | H | L | H | H | L | L | X | | | | | |  |
| | H | H | X | X | | | | | | | | | |  |
| Enter DPD | H | L | L | H | H | L | X | | | | | |  | |
| | X | L | X | X | | | | | | | | | |  |
| NOP | H | H | L | H | H | H | X | | | | | |  | |
| | H | H | X | X | | | | | | | | | |  |
| Maintain PD, SREF, DPD, (NOP) | L | L | L | H | H | H | X | | | | | |  | |
| | L | L | X | X | | | | | | | | | |  |
| NOP | H | H | H | X | | | | | | | | | |  |
| | H | H | X | X | | | | | | | | | |  |
| Maintain PD, SREF, DPD, (NOP) | L | L | H | X | | | | | | | | | |  |
| | L | L | X | X | | | | | | | | | |  |
| Enter power-down | H | L | H | X | | | | | | | | | |  |
| | X | L | X | X | | | | | | | | | |  |
| Exit PD, SREF, DPD | L | H | H | X | | | | | | | | | |  |
| | X | H | X | X | | | | | | | | | |  |

- Notes :
1. All commands are defined by the current state of CS#, CA0, CA1, CA2, CA3, and CKE at the rising edge of the clock.
 2. Bank addresses (BA) determine which bank will be operated upon.
 3. AP HIGH during a READ or WRITE command indicates that an auto precharge will occur To the bank associated with the READ or WRITE command.

4. X indicates a “Don’t Care” state, with a defined logic level, either HIGH (H) or LOW (L).
5. Self refresh exit and DPD exit are asynchronous.
6. VREF must be between 0 and VDDQ during self refresh and DPD operation.
7. CA_{xr} refers to command/address bit “x” on the rising edge of clock.
8. CA_{xf} refers to command/address bit “x” on the falling edge of clock.
9. CS# and CKE are sampled on the rising edge of the clock.
10. Per-bank refresh is only supported in devices with eight banks.
11. The least-significant column address C0 is not transmitted on the CA bus, and is inferred to be zero.

Table31 : CKE Truth Table

Notes 1–5 apply to all parameters and conditions ; L=LOW , H=HIGH , X=“Don’t Care”

| Current State | CKEn-1 | CKEn | CS# | Command n | Operation n | Next State | Notes | |
|---------------------------|--------|------|----------------------------------|--------------------|-------------------------------|----------------------|---------|--|
| Active power-down | L | L | X | X | Maintain active power-down | Active power-down | | |
| | L | H | H | NOP | Exit active power-down | Active | 6, 7 | |
| Idle power-down | L | L | X | X | Maintain idle power-down | Idle power-down | | |
| | L | H | H | NOP | Exit idle power-down | Idle | 6, 7 | |
| Resetting idle power-down | L | L | X | X | Maintain resetting power-down | Resetting power-down | | |
| | L | H | H | NOP | Exit resetting power-down | Idle or resetting | 6, 7, 8 | |
| Deep power-down | L | L | X | X | Maintain deep power-down | Deep power-down | | |
| | L | H | H | NOP | Exit deep power-down | Power-on | 9 | |
| Self refresh | L | L | X | X | Maintain self refresh | Self refresh | | |
| | L | H | H | NOP | Exit self refresh | Idle | 10, 11 | |
| Bank(s) active | H | L | H | NOP | Enter active power-down | Active power-down | | |
| All banks idle | H | L | H | NOP | Enter idle power-down | Idle power-down | | |
| | H | L | L | Enter self refresh | Enter self refresh | Self refresh | | |
| | H | L | L | DPD | Enter deep power-down | Deep power-down | | |
| Resetting | H | L | H | NOP | Enter deep power-down | Resetting power-down | | |
| Other states | H | H | Refer to the command truth table | | | | | |

- Notes :
1. Current state = the state of the device immediately prior to the clock rising edge *n*.
 2. All states and sequences not shown are illegal or reserved unless explicitly described elsewhere in this document.
 3. CKEn = the logic state of CKE at clock rising edge *n*; CKEn-1 was the state of CKE at the previous clock edge.
 4. CS# = the logic state of CS# at the clock rising edge *n*.
 5. Command *n* = the command registered at clock edge *n*, and operation *n* is a result of command *n*.
 6. Power-down exit time (t_{XP}) must elapse before any command other than NOP is issued.

7. The clock must toggle at least twice prior to the tXP period.
8. Upon exiting the resetting power-down state, the device will return to the idle state if tINIT5 has expired.
9. The DPD exit procedure must be followed as described in Deep Power-Down (page 60).
10. Self refresh exit time (tXSR) must elapse before any command other than NOP is issued.
11. The clock must toggle at least twice prior to the tXSR time.

Table32 : Current State Bank *n* to Command to Bank *n* Truth Table

Notes 1–5 apply to all parameters and conditions

| Current State | Command | Operation | Next State | Notes |
|---------------|---------------------|---|------------------------|------------|
| Any | NOP | Continue previous operation | Current state | |
| Idle | ACTIVATE | Select and activate row | Active | |
| | Refresh (per bank) | Begin to refresh | Refreshing (per bank) | 6 |
| | Refresh (all banks) | Begin to refresh | Refreshing (all banks) | 7 |
| | MRW | Load value to mode register | MR writing | 7 |
| | MRR | Read value from mode register | Idle, MR reading | |
| | RESET | Begin device auto initialization | Resetting | 7, 8 |
| | PRECHARGE | Deactivate row(s) in bank or banks | Precharging | 9, 10 |
| Row active | READ | Select column and start read burst | Reading | |
| | WRITE | Select column and start write burst | Writing | |
| | MRR | Read value from mode register | Active MR reading | |
| | PRECHARGE | Deactivate row(s) in bank or banks | Precharging | 9 |
| Reading | READ | Select column and start new read burst | Reading | 11, 12 |
| | WRITE | Select column and start write burst | Writing | 11, 12, 13 |
| | BST | Read burst terminate | Active | 14 |
| Writing | WRITE | Select column and start new write burst | Writing | 11, 12 |
| | READ | Select column and start read burst | Reading | 11, 12, 15 |
| | BST | Write burst terminate | Active | 14 |
| Power-on | MRW RESET | Begin device auto initialization | Resetting | 7, 9 |
| Resetting | MRR | Read value from mode register | Resetting MR reading | |

- Notes :
1. Values in this table apply when both CKE_{n-1} and CKE_n are HIGH, and after tXSR or tXP has been met, if the previous state was power-down.
 2. All states and sequences not shown are illegal or reserved.
 3. Current state definitions: Idle: The bank or banks have been precharged, and tRP has been met.
Active : A row in the bank has been activated, and tRCD has been met. No data bursts or accesses and no register accesses are in progress. Reading: A READ burst has been initiated with auto precharge disabled and has not yet terminated or been terminated. Writing: A WRITE burst has been initiated with auto precharge disabled and has not yet terminated or been terminated.
 4. The states listed below must not be interrupted by a command issued to the same bank.
NOP commands or supported commands to the other bank must be issued on any clock edge occurring during these states. Supported commands to the other banks are determined by that bank's current state, and the definitions given in Table 33.

Precharge: Starts with registration of a PRECHARGE command and ends when tRP is met. After tRP is met, the bank is in the idle state.

Row activate: Starts with registration of an ACTIVATE command and ends when tRCD is met. After tRCD is met, the bank is in the active state. READ with AP enabled: Starts with registration of a READ command with auto precharge enabled and ends when tRP is met. After tRP is met, the bank is in the idle state.

WRITE with AP enabled: Starts with registration of a WRITE command with auto precharge enabled and ends when tRP is met. After tRP is met, the bank is in the idle state.

5. The states listed below must not be interrupted by any executable command. NOP commands must be applied to each rising clock edge during these states. Refresh (per bank): Starts with registration of a REFRESH (per bank) command and ends when tRFCpb is met. After tRFCpb is met, the bank is in the idle state. Refresh (all banks): Starts with registration of a REFRESH (all banks) command and ends when tRFCab is met. After tRFCab is met, the device is in the all banks idle state. Idle MR reading: Starts with registration of the MRR command and ends when tMRR is met. After tMRR is met, the device is in the all banks idle state. Resetting MR reading: Starts with registration of the MRR command and ends when tMRR is met. After tMRR is met, the device is in the all banks idle state. Active MR reading: Starts with registration of the MRR command and ends when tMRR is met. After tMRR is met, the bank is in the active state. MR writing: Starts with registration of the MRW command and ends when tMRW is met. After tMRW is met, the device is in the all banks idle state. Precharging all: Starts with registration of a PRECHARGE ALL command and ends when tRP is met. After tRP is met, the device is in the all banks idle state.
6. Bank-specific; requires that the bank is idle and no bursts are in progress.
7. Not bank-specific; requires that all banks are idle and no bursts are in progress.
8. Not bank-specific.
9. This command may or may not be bank specific. If all banks are being precharged, they must be in a valid state for precharging.
10. If a PRECHARGE command is issued to a bank in the idle state, tRP still applies.
11. A command other than NOP should not be issued to the same bank while a burst READ or burst WRITE with auto precharge is enabled.
12. The new READ or WRITE command could be auto precharge enabled or auto precharge disabled.
13. A WRITE command can be issued after the completion of the READ burst; otherwise, a BST must be issued to end the READ prior to asserting a WRITE command.
14. Not bank-specific. The BST command affects the most recent READ/WRITE burst started by the most recent READ / WRITE command, regardless of bank.
15. A READ command can be issued after completion of the WRITE burst; otherwise, a BST must be used to end the WRITE prior to asserting another READ command.

Table 33: Current State Bank *n* to Command to Bank *m* Truth Table

Notes 1–6 apply to all parameters and conditions

| Current State of Bank <i>n</i> | Command to Bank <i>m</i> | Operation | Next State for Bank <i>m</i> | notes |
|--|--------------------------|--|--------------------------------------|----------|
| Any | NOP | Continue previous operation | Current State of Bank <i>m</i> | |
| Idle | Any | Any command supported to Bank <i>m</i> | - | 7 |
| Row activating, active, or precharging | ACTIVATE | Select and activate row in bank <i>m</i> | Active | 8 |
| | READ | Select column and start READ Burst from bank <i>m</i> | Reading | 9 |
| | WRITE | Select column and start WRITE burst to bank <i>m</i> | Writing | 9 |
| | PRECHARGE | Deactivate row(s) in bank or banks | Precharging | 10 |
| | MRR | READ value from mode register | Idle MR reading or Active MR reading | 11,12,13 |
| | BST | READ or WRITE burst terminates an ongoing READ/WRITE from/to bank <i>m</i> | Active | 7 |
| Reading (auto precharge disabled) | READ | Select column and start READ burst from bank <i>m</i> | Reading | 9 |
| | WRITE | Select column and start WRITE burst to bank <i>m</i> | Writing | 9,14 |
| | ACTIVATE | Select and activate row in bank <i>m</i> | Active | |
| | PRECHARGE | Deactivate row(s) in bank or banks | Precharging | 10 |
| Writing (auto precharge disabled) | READ | Select column and start READ burst from bank <i>m</i> | Reading | 9,15 |
| | WRITE | Select column and start WRITE burst to bank <i>m</i> | Writing | 9 |
| | ACTIVATE | Select and activate row in bank <i>m</i> | Active | |
| | PRECHARGE | Deactivate row(s) in bank or banks | Precharging | 10 |
| Reading with auto precharge | READ | Select column and start READ burst from bank <i>m</i> | Reading | 9,16 |
| | WRITE | Select column and start WRITE burst to bank <i>m</i> | Writing | 9,14,16 |
| | ACTIVATE | Select and activate row in bank <i>m</i> | Active | |
| | PRECHARGE | Deactivate row(s) in bank or banks | Precharging | 10 |
| Writing with auto precharge | READ | Select column and start READ burst from bank <i>m</i> | Reading | 9,15,16 |
| | WRITE | Select column and start WRITE burst to bank <i>m</i> | Writing | 9,16 |
| | ACTIVATE | Select and activate row in bank <i>m</i> | Active | |
| | PRECHARGE | Deactivate row(s) in bank or banks | Precharging | 10 |
| Power-on | MRW RESET | Begin device auto initialization | Resetting | 17,18 |
| Resetting | MRR | Read value from mode register | Resetting MR reading | |

Notes : 1. This table applies when: the previous state was self refresh or power-down ; after tXSR or tXP has been met; and both *CKEn -1* and *CKEn* are HIGH.

2. All states and sequences not shown are illegal or reserved.

3. Current state definitions:

Idle: The bank has been precharged and tRP has been met.

Active: A row in the bank has been activated, tRCD has been met, no data bursts or accesses and no register accesses

are in progress. Read: A READ burst has been initiated with auto precharge disabled and the READ has not yet terminated or been terminated. Write: A WRITE burst has been initiated with auto precharge disabled and the WRITE has not yet terminated or been terminated.

4. Refresh, self refresh, and MRW commands can only be issued when all banks are idle.

5. A BST command cannot be issued to another bank; it applies only to the bank represented by the current state.

6. The states listed below must not be interrupted by any executable command.

NOP commands must be applied during each clock cycle while in these states:

Idle MRR: Starts with registration of the MRR command and ends when tMRR has been met.

After tMRR is met, the device is in the all banks idle state.

Reset MRR: Starts with registration of the MRR command and ends when tMRR has been met.

After tMRR is met, the device is in the all banks idle state.

Active MRR: Starts with registration of the MRR command and ends when tMRR has been met.

After tMRR is met, the bank is in the active state.

MRW: Starts with registration of the MRW command and ends when tMRW has been met.

After tMRW is met, the device is in the all banks idle state.

7. BST is supported only if a READ or WRITE burst is ongoing.

8. tRRD must be met between the ACTIVATE command to bank *n* and any subsequent ACTIVATE command to bank *m*.

9. READs or WRITEs listed in the command column include READs and WRITEs with or without auto precharge enabled.

10. This command may or may not be bank-specific.

If all banks are being precharged, they must be in a valid state for precharging.

11. MRR is supported in the row-activating state.

12. MRR is supported in the precharging state.

13. The next state for bank *m* depends on the current state of bank *m* (*idle*, *row-activating*, *precharging*, or *active*).

14. A WRITE command can be issued after the completion of the READ burst;

otherwise a BST must be issued to end the READ prior to asserting a WRITE command.

15. A READ command can be issued after the completion of the WRITE burst;

otherwise, a BST must be issued to end the WRITE prior to asserting another READ command.

16. A READ with auto precharge enabled or a WRITE with auto precharge enabled can be followed by any valid command to

other banks provided that the timing restrictions in the PRECHARGE and Auto Precharge Clarification table are met.

17. Not bank-specific; requires that all banks are idle and no bursts are in progress.

18. RESET command is achieved through MODE REGISTER WRITE command.

Table 34: DM Truth Table

| Functional Name | DM | DQ | notes |
|-----------------|----|-------|-------|
| Write enable | L | Valid | 1 |
| Write inhibit | H | X | 1 |

Note : 1. Used to mask write data, and is provided simultaneously with the corresponding input data.

Electrical Specifications

Absolute Maximum Ratings

Stresses greater than those listed below may cause permanent damage to the device.

This is a stress rating only, and functional operation of the device at these or any other conditions outside those indicated in the operational sections of this document is not implied.

Exposure to absolute maximum rating conditions for extended periods may adversely affect reliability.

Table 35: Absolute Maximum DC Ratings

| Parameter | Symbol | Min | Max | Unit | Notes |
|--|------------------------------------|------|------|------|-------|
| VDD1 supply voltage relative to VSS | VDD1 | -0.4 | +2.3 | V | 1 |
| VDD2 supply voltage relative to VSS | VDD2 (1.2V) | -0.4 | +1.6 | V | 1 |
| VDDCA supply voltage relative to VSSCA | VDDCA | -0.4 | +1.6 | V | 1,2 |
| VDDQ supply voltage relative to VSSQ | VDDQ | -0.4 | +1.6 | V | 1,3 |
| Voltage on any ball relative to VSS | V _{IN} , V _{OUT} | -0.4 | +1.6 | V | |
| Storage temperature | T _{STG} | -55 | +125 | °C | 4 |

Notes : 1. See 1. Voltage Ramp under Power-Up (page 7).

2. VREFCA 0.6 ≤ VDDCA; however, VREFCA may be ≥ VDDCA provided that VREFCA ≤ 300mV.

3. VREFDQ 0.6 ≤ VDDQ; however, VREFDQ may be ≥ VDDQ provided that VREFDQ ≤ 300mV.

4. Storage temperature is the case surface temperature on the center/top side of the device.

For measurement conditions, refer to the JESD51-2 standard.

Input/Output Capacitance

Table 36: Input/Output Capacitance

Note 1 applies to all parameters and conditions

| Parameter | Symbol | LPDDR2 800-466 | | LPDDR2 400-200 | | Unit | Notes |
|--|--------|----------------|-------|----------------|-------|------|-------|
| | | Min | Max | Min | Max | | |
| Input capacitance, CK and CK# | CCK | 1.0 | 2.0 | 1.0 | 2.0 | pF | 1 |
| Input capacitance delta, CK and CK# | CDCK | 0 | 0.2 | 0 | 0.25 | pF | 1 |
| Input capacitance, all other input Only pins | CI | 1.0 | 2.0 | 1.0 | 2.0 | pF | 1,2 |
| Input capacitance delta, all other input Only pins | CDI | -0.40 | +0.40 | -0.50 | +0.50 | pF | 1,3 |
| Input/output capacitance, DQ,DM,DQS, DQS# | CIO | 1.25 | 2.5 | 1.25 | 2.5 | pF | |
| Input/output capacitance delta, DQS, DQS# | CDDQS | 0 | 0.25 | 0 | 0.30 | pF | |
| Input/output capacitance delta, DQ,DM | CDIO | -0.5 | +0.5 | -0.6 | +0.6 | pF | |
| Input/output capacitance ZQ | CZQ | 0 | 2.5 | 0 | 2.5 | pF | 4 |

Notes : 1. T_c -40°C to +105°C; VDDQ = 1.14–1.3V; VDDCA = 1.14–1.3V; VDD1 = 1.7–1.95V; VDD2 = 1.14–1.3V.

2. This parameter applies to die devices only (does not include package capacitance).

3. This parameter is not subject to production testing. It is verified by design and characterization.

The capacitance is measured according to JEP147 (procedure for measuring input capacitance using a vector network analyzer), with VDD1, VDD2, VDDQ, VSS, VSSCA, and VSSQ applied; all other pins are left floating.

4. Absolute value of C_{ck} - C_{ck#}.

5. C_i applies to CS#, CKE, and CA[9:0].

6. $C_{DI} = C_I - 0.5 \times (C_{CK} + C_{CK\#})$.
7. DM loading matches DQ and DQS.
8. MR3 I/O configuration drive strength OP[3:0] = 0001b (34.3 ohm typical).
9. Absolute value of C_{DQS} and $C_{DQS\#}$.
10. $C_{DIO} = C_{IO} - 0.5 \times (C_{DQS} + C_{DQS\#})$ in byte-lane.
11. Maximum external load capacitance on ZQ pin: 5pF.

Electrical Specifications – IDD Specifications and Conditions

The following definitions and conditions are used in the IDD measurement tables unless stated otherwise:

- LOW: $V_{IN} \leq V_{IL}(DC)_{max}$
- HIGH: $V_{IN} \geq V_{IH}(DC)_{min}$
- STABLE: Inputs are stable at a HIGH or LOW level
- SWITCHING: See the following three tables

Table 37: Switching for CA Input Signals

Notes 1–3 apply to all parameters and conditions

| Parameter | CK Rising/ CK# Falling | CK Rising/ CK# Falling | CK Rising/ CK# Falling | CK Rising/ CK# Falling | CK Rising/ CK# Falling | CK Rising/ CK# Falling | CK Rising/ CK# Falling | CK Rising/ CK# Falling |
|-----------|---------------------------|---------------------------|---------------------------|---------------------------|---------------------------|---------------------------|---------------------------|---------------------------|
| Cycle | N | | N+1 | | N+2 | | N+3 | |
| CS# | HIGH | | HIGH | | HIGH | | HIGH | |
| CA0 | H | L | L | L | L | H | H | H |
| CA1 | H | H | H | L | L | L | L | H |
| CA2 | H | L | L | L | L | H | H | H |
| CA3 | H | H | H | L | L | L | L | H |
| CA4 | H | L | L | L | L | H | H | H |
| CA5 | H | H | H | L | L | L | L | H |
| CA6 | H | L | L | L | L | H | H | H |
| CA7 | H | H | H | L | L | L | L | H |
| CA8 | H | L | L | L | L | H | H | H |
| CA9 | H | H | H | L | L | L | L | H |

- Notes : 1. CS# must always be driven HIGH.
2. For each clock cycle, 50% of the CA bus is changing between HIGH and LOW.
 3. The noted pattern (N, N + 1, N + 2, N + 3...) is used continuously during I_{DD} measurement for I_{DD} values that require switching on the CA bus.

Table 38: Switching for IDD4R

| Clock | CKE | CS# | Clock Cycle Number | Command | CA[2:0] | CA[9:3] | All DQ |
|---------|-----|-----|--------------------|--------------|---------|---------|--------|
| Rising | H | L | N | Read_Rising | HLH | LHLHLHL | L |
| Falling | H | L | N | Read_Falling | LLL | LLLLLLL | L |
| Rising | H | H | N+1 | NOP | LLL | LLLLLLL | H |
| Falling | H | H | N+1 | NOP | HLH | LHLLHLH | L |
| Rising | H | L | N+2 | Read_Rising | HLH | LHLLHLH | H |
| Falling | H | L | N+2 | Read_Falling | LLL | HHHHHHH | H |
| Rising | H | H | N+3 | NOP | LLL | HHHHHHH | H |
| Falling | H | H | N+3 | NOP | HLH | LHLHLHL | L |

Notes : 1. Data strobe (DQS) is changing between HIGH and LOW with every clock cycle.

2. The noted pattern (N, N + 1...) is used continuously during IDD measurement for IDD4R

Table 39: Switching for IDD4W

| Clock | CKE | CS# | Clock Cycle Number | Command | CA[2:0] | CA[9:3] | All DQ |
|---------|-----|-----|--------------------|---------------|---------|---------|--------|
| Rising | H | L | N | Write Rising | LLH | LHLHLHL | L |
| Falling | H | L | N | Write Falling | LLL | LLLLLLL | L |
| Rising | H | H | N+1 | NOP | LLL | LLLLLLL | H |
| Falling | H | H | N+1 | NOP | LLH | LHLLHLH | L |
| Rising | H | L | N+2 | Write Rising | LLH | LHLLHLH | H |
| Falling | H | L | N+2 | Write Falling | LLL | HHHHHHH | H |
| Rising | H | H | N+3 | NOP | LLL | HHHHHHH | H |
| Falling | H | H | N+3 | NOP | LLH | LHLHLHL | L |

Notes : 1. Data strobe (DQS) is changing between HIGH and LOW with every clock cycle.

2. Data masking (DM) must always be driven LOW.

3. The noted pattern (N, N + 1...) is used continuously during IDD measurement for IDD4W.

Table 40: IDD Specification and Conditions(X16)

| Parameter / Condition | Symbol | Power Supply | Data Rate | Unit | Notes |
|---|-----------|--------------|-----------|------|-------|
| | | | -25 | | |
| Operating one bank active-precharge current (SDRAM) : tCK = tCKmin; tRC = tRCmin; CKE is HIGH; CS# is HIGH between valid commands; CA bus inputs are switching; Data bus inputs are stable | IDD01 | VDD1 | 15 | mA | 4 |
| | IDD02 | VDD2 | 65 | | |
| | IDD0in | VDDCA,VDDQ | 6 | | |
| Idle power-down standby current: tCK = tCKmin; CKE is LOW; CS# is HIGH; All banks are idle; CA bus inputs are switching; Data bus inputs are stable | IDD2P1 | VDD1 | 500 | μA | 4 |
| | IDD2P2 | VDD2 | 500 | | |
| | IDD2P,in | VDDCA,VDDQ | 20 | | |
| Idle power-down standby current with clock stop: CK = LOW, CK# = HIGH; CKE is LOW; CS# is HIGH; All banks are idle; CA bus inputs are stable; Data bus inputs are stable | IDD2PS1 | VDD1 | 500 | μA | 4 |
| | IDD2PS2 | VDD2 | 500 | | |
| | IDD2PS,in | VDDCA,VDDQ | 20 | | |
| Idle non-power-down standby current: tCK = tCKmin; CKE is HIGH; CS# is HIGH; All banks are idle; CA bus inputs are switching; Data bus inputs are stable | IDD2N1 | VDD1 | 1 | mA | 4 |
| | IDD2N2 | VDD2 | 33 | | |
| | IDD2N,in | VDDCA,VDDQ | 6 | | |
| Idle non-power-down standby current with clock stopped: CK = LOW; CK# = HIGH; CKE is HIGH; CS# is HIGH; All banks are idle; CA bus inputs are stable; Data bus inputs are stable | IDD2NS1 | VDD1 | 1 | mA | 4 |
| | IDD2NS2 | VDD2 | 3 | | |
| | IDD2NS,in | VDDCA, VDDQ | 6 | | |
| Active power-down standby current: tCK = tCKmin; CKE is LOW; CS# is HIGH; One bank is active; CA bus inputs are switching; Data bus inputs are stable | IDD3P1 | VDD1 | 500 | μA | 4 |
| | IDD3P2 | VDD2 | 2 | mA | |
| | IDD3P,in | VDDCA, VDDQ | 20 | μA | |
| Active power-down standby current with clock stop: CK = LOW, CK# = HIGH; CKE is LOW; CS# is HIGH; One bank is active; CA bus inputs are stable; Data bus inputs are stable | IDD3PS1 | VDD1 | 500 | μA | 4 |
| | IDD3PS2 | VDD2 | 2 | mA | |
| | IDD3PS,in | VDDCA, VDDQ | 20 | μA | |
| Active non-power-down standby current: tCK = tCKmin; CKE is HIGH; CS# is HIGH; One bank is active; CA bus inputs are switching; Data bus inputs are stable | IDD3N1 | VDD1 | 2 | mA | 4 |
| | IDD3N2 | VDD2 | 40 | | |
| | IDD3N,in | VDDCA, VDDQ | 6 | | |
| Active non-power-down standby current with clock stopped : CK = LOW, CK# = HIGH CKE is HIGH; CS# is HIGH; One bank is active; CA bus inputs are stable; Data bus inputs are stable | IDD3NS1 | VDD1 | 2 | mA | 4 |
| | IDD3NS2 | VDD2 | 4 | | |
| | IDD3NS,in | VDDCA, VDDQ | 4 | | |

Table 41: IDD Specification and Conditions(X16) (continued)

| Parameter / Condition | Symbol | Power Supply | Data Rate | Unit | Notes |
|--|-----------|--------------|-----------|------|-------|
| | | | -25 | | |
| Operating burst READ current: tCK = tCKmin; CS# is HIGH between valid commands; One bank is active; BL = 4; RL = RL (MIN); CA bus inputs are switching; 50% data change each burst transfer | IDD4R1 | VDD1 | 4 | mA | |
| | IDD4R2 | VDD2 | 150 | | |
| | IDD4R,in | VDDCA | 6 | | |
| Operating burst WRITE current: tCK = tCKmin; CS# is HIGH between valid commands; One bank is active; BL = 4; WL = WLmin; CA bus inputs are switching; 50% data change each burst transfer | IDD4W1 | VDD1 | 4 | mA | |
| | IDD4W2 | VDD2 | 130 | | |
| | IDD4W,in | VDDCA, VDDQ | 10 | | 4 |
| All-bank REFRESH burst current: tCK = tCKmin; CKE is HIGH between valid commands; tRC = tRFCabmin; Burst refresh; CA bus inputs are switching; Data bus inputs are stable | IDD51 | VDD1 | 15 | mA | |
| | IDD52 | VDD2 | 120 | | |
| | IDD5IN | VDDCA, VDDQ | 6 | | 4 |
| All-bank REFRESH average current: tCK = tCKmin; CKE is HIGH between valid commands; tRC = tREFI; CA bus inputs are switching; Data bus inputs are stable | IDD5AB1 | VDD1 | 2 | mA | |
| | IDD5AB2 | VDD2 | 35 | | |
| | IDD5AB,in | VDDCA, VDDQ | 6 | | 4 |
| Per-bank REFRESH average current: tCK = tCKmin; CKE is HIGH between valid commands; tRC = tREFI/8; CA bus inputs are switching; Data bus inputs are stable | IDD5PB1 | VDD1 | 2 | mA | 5 |
| | IDD5PB2 | VDD2 | 35 | | 5 |
| | IDD5PB,in | VDDCA, VDDQ | 6 | | 4, 5 |
| Self refresh current (-25°C to +85°C): CK = LOW, CK# = HIGH; CKE is LOW; CA bus inputs are stable; Data bus inputs are stable; Maximum 1x self refresh rate | IDD61 | VDD1 | 1000 | µA | 6 |
| | IDD62 | VDD2 | 2500 | | 6 |
| | IDD6IN | VDDCA, VDDQ | 30 | | 4,6 |
| Deep power-down current: CK = LOW, CK# = HIGH; CKE is LOW; CA bus inputs are stable; Data bus inputs are stable | IDD81 | VDD1 | 10 | µA | 7 |
| | IDD82 | VDD2 | 30 | | 7 |
| | IDD8IN | VDDCA, VDDQ | 30 | | 4, 7 |

- Notes :
1. IDD values are the maximum of the distribution of the arithmetic mean.
 2. IDD current specifications are tested after the device is properly initialized.
 3. The 1x self refresh rate is the rate at which the device is refreshed internally during self refresh, before going into the extended temperature range.
 4. Measured currents are the sum of VDDQ and VDDCA.
 5. Per-bank REFRESH is only applicable for LPDDR2-S4 device densities 1Gb or higher.
 6. This is the general definition that applies to full-array self refresh.
 7. IDD6ET and IDD8 are typical values, are sampled only, and are not tested.

Table 42: IDD Specification and Conditions(X32)

| Parameter / Condition | Symbol | Power Supply | Data Rate | Unit | Notes |
|---|-----------|--------------|-----------|------|-------|
| | | | -25 | | |
| Operating one bank active-precharge current (SDRAM) : tCK = tCKmin; tRC = tRCmin; CKE is HIGH; CS# is HIGH between valid commands; CA bus inputs are switching; Data bus inputs are stable | IDD01 | VDD1 | 15 | mA | 4 |
| | IDD02 | VDD2 | 65 | | |
| | IDD0in | VDDCA,VDDQ | 6 | | |
| Idle power-down standby current: tCK = tCKmin; CKE is LOW; CS# is HIGH; All banks are idle; CA bus inputs are switching; Data bus inputs are stable | IDD2P1 | VDD1 | 500 | μA | 4 |
| | IDD2P2 | VDD2 | 500 | | |
| | IDD2P,in | VDDCA,VDDQ | 20 | | |
| Idle power-down standby current with clock stop: CK = LOW, CK# = HIGH; CKE is LOW; CS# is HIGH; All banks are idle; CA bus inputs are stable; Data bus inputs are stable | IDD2PS1 | VDD1 | 500 | μA | 4 |
| | IDD2PS2 | VDD2 | 500 | | |
| | IDD2PS,in | VDDCA,VDDQ | 20 | | |
| Idle non-power-down standby current: tCK = tCKmin; CKE is HIGH; CS# is HIGH; All banks are idle; CA bus inputs are switching; Data bus inputs are stable | IDD2N1 | VDD1 | 1 | mA | 4 |
| | IDD2N2 | VDD2 | 33 | | |
| | IDD2N,in | VDDCA,VDDQ | 6 | | |
| Idle non-power-down standby current with clock stopped: CK = LOW; CK# = HIGH; CKE is HIGH; CS# is HIGH; All banks are idle; CA bus inputs are stable; Data bus inputs are stable | IDD2NS1 | VDD1 | 1 | mA | 4 |
| | IDD2NS2 | VDD2 | 3 | | |
| | IDD2NS,in | VDDCA, VDDQ | 6 | | |
| Active power-down standby current: tCK = tCKmin; CKE is LOW; CS# is HIGH; One bank is active; CA bus inputs are switching; Data bus inputs are stable | IDD3P1 | VDD1 | 500 | μA | 4 |
| | IDD3P2 | VDD2 | 2 | mA | |
| | IDD3P,in | VDDCA, VDDQ | 20 | μA | |
| Active power-down standby current with clock stop: CK = LOW, CK# = HIGH; CKE is LOW; CS# is HIGH; One bank is active; CA bus inputs are stable; Data bus inputs are stable | IDD3PS1 | VDD1 | 500 | μA | 4 |
| | IDD3PS2 | VDD2 | 2 | mA | |
| | IDD3PS,in | VDDCA, VDDQ | 20 | μA | |
| Active non-power-down standby current: tCK = tCKmin; CKE is HIGH; CS# is HIGH; One bank is active; CA bus inputs are switching; Data bus inputs are stable | IDD3N1 | VDD1 | 2 | mA | 4 |
| | IDD3N2 | VDD2 | 40 | | |
| | IDD3N,in | VDDCA, VDDQ | 6 | | |
| Active non-power-down standby current with clock stopped : CK = LOW, CK# = HIGH CKE is HIGH; CS# is HIGH; One bank is active; CA bus inputs are stable; Data bus inputs are stable | IDD3NS1 | VDD1 | 2 | mA | 4 |
| | IDD3NS2 | VDD2 | 4 | | |
| | IDD3NS,in | VDDCA, VDDQ | 4 | | |

Table 43: IDD Specification and Conditions(X32) (continued)

| Parameter / Condition | Symbol | Power Supply | Data Rate | Unit | Notes |
|--|-----------|--------------|-----------|------|-------|
| | | | -25 | | |
| Operating burst READ current: tCK = tCKmin; CS# is HIGH between valid commands; One bank is active; BL = 4; RL = RL (MIN); CA bus inputs are switching; 50% data change each burst transfer | IDD4R1 | VDD1 | 4 | mA | |
| | IDD4R2 | VDD2 | 150 | | |
| | IDD4R,in | VDDCA | 6 | | |
| Operating burst WRITE current: tCK = tCKmin; CS# is HIGH between valid commands; One bank is active; BL = 4; WL = WLmin; CA bus inputs are switching; 50% data change each burst transfer | IDD4W1 | VDD1 | 4 | mA | |
| | IDD4W2 | VDD2 | 130 | | |
| | IDD4W,in | VDDCA, VDDQ | 10 | | 4 |
| All-bank REFRESH burst current: tCK = tCKmin; CKE is HIGH between valid commands; tRC = tRFCabmin; Burst refresh; CA bus inputs are switching; Data bus inputs are stable | IDD51 | VDD1 | 15 | mA | |
| | IDD52 | VDD2 | 120 | | |
| | IDD5IN | VDDCA, VDDQ | 6 | | 4 |
| All-bank REFRESH average current: tCK = tCKmin; CKE is HIGH between valid commands; tRC = tREFI; CA bus inputs are switching; Data bus inputs are stable | IDD5AB1 | VDD1 | 2 | mA | |
| | IDD5AB2 | VDD2 | 35 | | |
| | IDD5AB,in | VDDCA, VDDQ | 6 | | 4 |
| Per-bank REFRESH average current: tCK = tCKmin; CKE is HIGH between valid commands; tRC = tREFI/8; CA bus inputs are switching; Data bus inputs are stable | IDD5PB1 | VDD1 | 2 | mA | 5 |
| | IDD5PB2 | VDD2 | 35 | | 5 |
| | IDD5PB,in | VDDCA, VDDQ | 6 | | 4, 5 |
| Self refresh current (-25°C to +85°C): CK = LOW, CK# = HIGH; CKE is LOW; CA bus inputs are stable; Data bus inputs are stable; Maximum 1x self refresh rate | IDD61 | VDD1 | 1000 | µA | 6 |
| | IDD62 | VDD2 | 2500 | | 6 |
| | IDD6IN | VDDCA, VDDQ | 30 | | 4,6 |
| Deep power-down current: CK = LOW, CK# = HIGH; CKE is LOW; CA bus inputs are stable; Data bus inputs are stable | IDD81 | VDD1 | 10 | µA | 7 |
| | IDD82 | VDD2 | 30 | | 7 |
| | IDD8IN | VDDCA, VDDQ | 30 | | 4, 7 |

- Notes :
1. IDD values are the maximum of the distribution of the arithmetic mean.
 2. IDD current specifications are tested after the device is properly initialized.
 3. The 1x self refresh rate is the rate at which the device is refreshed internally during self refresh, before going into the extended temperature range.
 4. Measured currents are the sum of VDDQ and VDDCA.
 5. Per-bank REFRESH is only applicable for LPDDR2-S4 device densities 1Gb or higher.
 6. This is the general definition that applies to full-array self refresh.
 7. IDD6ET and IDD8 are typical values, are sampled only, and are not tested.

Table 44: IDD6 Partial-Array Self Refresh Current

VDD2, VDDQ, VDDCA = 1.14–1.30V; VDD1 = 1.70–1.95V

| PASR | Symbol | Power Supply | Unit |
|------------|--------|--------------|------|
| Full array | VDD1 | 1400 | μA |
| | VDD2 | 3000 | |
| | VDDi | 100 | |
| 1/2 array | VDD1 | 1200 | |
| | VDD2 | 2500 | |
| | VDDi | 100 | |
| 1/4 array | VDD1 | 1000 | |
| | VDD2 | 2300 | |
| | VDDi | 100 | |
| 1/8 array | VDD1 | 1000 | |
| | VDD2 | 2000 | |
| | VDDi | 100 | |

AC and DC Operating Conditions

Operation or timing that is not specified is illegal. To ensure proper operation, the device must be initialized properly.

Table 45: Recommended DC Operating Conditions

| Symbol | LPDDR2-S4B | | | Power Supply | Unit |
|--------|------------|------|------|--------------------|------|
| | Min | Typ | Max | | |
| VDD1 | 1.70 | 1.80 | 1.95 | Core power 1 | V |
| VDD2 | 1.14 | 1.20 | 1.30 | Core power2 | V |
| VDDCA | 1.14 | 1.20 | 1.30 | Input buffer power | V |
| VDDQ | 1.14 | 1.20 | 1.30 | I/O buffer power | V |

Note : 1. VDD1 uses significantly less power than VDD2.

Table 46: Input Leakage Current

| Parameter/Condition | Symbol | Min | Max | Unit | Notes |
|--|-------------------|-----|-----|------|-------|
| Input leakage current : For CA, CKE, CS#, CK, CK#; Any input $0V \leq V_{IN} \leq V_{DDCA}$; (All other pins not under test = 0V) | IL | -2 | 2 | uA | 1 |
| VREF supply leakage current : $V_{REFDQ} = V_{DDQ}/2$, or $V_{REFCA} = V_{DDCA}/2$; (All other pins not under test = 0V) | I _{VREF} | -1 | 1 | uA | 2 |

Note : 1. Although DM is for input only, the DM leakage must match the DQ and DQS/DQS# output leakage specification.

2. The minimum limit requirement is for testing purposes. The leakage current on VREFCA and VREFDQ pins should be minimal.

Table 47: Operating Temperature Range

| Parameter/Condition | Symbol | Min | Max | Unit |
|----------------------|--------|-----|-----|------|
| IT temperature range | TCASE | -40 | +85 | °C |

Note : 1. Operating temperature is the case surface temperature at the center of the top side of the device.

For measurement conditions, refer to the JESD51-2 standard.

- Some applications require operation in the maximum case temperature range, between 85°C and 105°C. For some LPDDR2 devices, derating may be necessary to operate in this range (see the MR4 Device Temperature (MA[7:0] = 04h) table).
- Either the device operating temperature or the temperature sensor can be used to set an appropriate refresh rate, determine the need for AC timing derating, and/or monitor the operating temperature (see Temperature Sensor (page 47)). When using the temperature sensor, the actual device case temperature may be higher than the TCASE rating that applies for the operating temperature range. For example, TCASE could be above 85°C when the temperature sensor indicates a temperature of less than 85°C.

AC and DC Logic Input Measurement Levels for Single-Ended Signals

Table 48: Single-Ended AC and DC Input Levels for CA and CS# Inputs

| Symbol | Parameter | LPDDR2-800 to LPDDR2-466 | | LPDDR2-400 to LPDDR2-200 | | Unit | notes |
|-------------------------|---|--------------------------|--------------------------|--------------------------|--------------------------|------|-------|
| | | Min | Max | Min | Max | | |
| V _{IHCA} (AC) | AC input logic HIGH | V _{REF} +0.220 | Note 2 | V _{REF} +0.300 | Note 2 | V | 1,2 |
| V _{ILCA} (AC) | AC input logic LOW | note 2 | V _{REF} -0.220 | note 2 | V _{REF} -0.300 | V | 1,2 |
| V _{IHCA} (DC) | DC input logic HIGH | V _{REF} +0.130 | V _{DDCA} | V _{REF} +0.200 | V _{DDCA} | V | 1 |
| V _{ILCA} (DC) | DC input logic LOW | V _{SSCA} | V _{REF} -0.130 | V _{SSCA} | V _{REF} -0.200 | V | 1 |
| V _{REFCA} (DC) | Reference voltage for CA and CS# inputs | 0.49 × V _{DDCA} | 0.51 × V _{DDCA} | 0.49 × V _{DDCA} | 0.51 × V _{DDCA} | V | 3, 4 |

- Note : 1. For CA and CS# input-only pins. V_{REF} = V_{REFCA}(DC).
 2. See Figure 65.
 3. The AC peak noise on V_{REFCA} could prevent V_{REFCA} from deviating more than ±1% V_{DDCA} from V_{REFCA}(DC) (for reference, approximately ±12mV).
 4. For reference, approximately V_{DDCA}/2 ±12mV.

Table 49: Single-Ended AC and DC Input Levels for CKE

| Symbol | Parameter | Min | Max | Unit | notes |
|--------------------|----------------------|-------------------------|-------------------------|------|-------|
| V _{IHCKE} | CKE input HIGH level | 0.8 X V _{DDCA} | Note 1 | V | 1 |
| V _{ILCKE} | CKE input LOW level | Note 1 | 0.2 X V _{DDCA} | V | 1 |

- Note : 1. See Figure 65.

Table 50: Single-Ended AC and DC Input Levels for DQ and DM

| Symbol | Parameter | LPDDR2-800 to LPDDR2-466 | | LPDDR2-400 to LPDDR2-200 | | Unit | notes |
|-------------------------|--|--------------------------|-------------------------|--------------------------|-------------------------|------|-------|
| | | Min | Max | Min | Max | | |
| V _{IHDQ} (AC) | AC input logic HIGH | V _{REF} +0.220 | Note 2 | V _{REF} +0.300 | Note 2 | V | 1,2 |
| V _{ILDQ} (AC) | AC input logic LOW | note 2 | V _{REF} -0.220 | Note 2 | V _{REF} -0.300 | V | 1,2 |
| V _{IHDQ} (DC) | DC input logic HIGH | V _{REF} +0.130 | V _{DDQ} | V _{REF} +0.200 | V _{DDQ} | V | 1 |
| V _{ILDQ} (DC) | DC input logic LOW | V _{SSQ} | V _{REF} -0.130 | V _{SSQ} | V _{REF} -0.200 | V | 1 |
| V _{REFDQ} (DC) | Reference voltage for DQ and DM inputs | 0.49 X V _{DDQ} | 0.51X V _{DDQ} | 0.49 X V _{DDQ} | 0.51 X V _{DDQ} | V | 3, 4 |

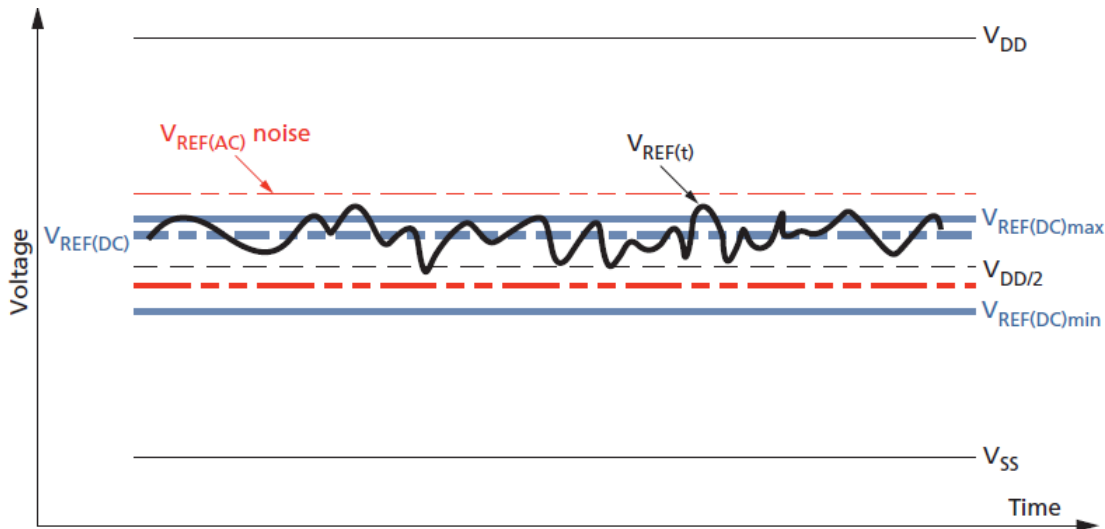
- Note : 1. For DQ input-only pins. V_{REF} = V_{REFDQ}(DC).
 2. See Figure 65.
 3. The AC peak noise on V_{REFDQ} could prevent V_{REFDQ} from deviating more than ±1% V_{DDQ} from V_{REFDQ}(DC) (for reference, approximately ±12mV).
 4. For reference, approximately. V_{DDQ}/2 ±12mV.

VREF Tolerances

The DC tolerance limits and AC noise limits for the reference voltages VREFCA and VREFDQ are illustrated below.

This figure shows a valid reference voltage VREF(t) as a function of time. VDD is used in place of VDDCA for VREFCA, and VDDQ for VREFDQ. VREF(DC) is the linear average of VREF(t) over a very long period of time (for example, 1 second) and is specified as a fraction of the linear average of VDDQ or VDDCA, also over a very long period of time (for example, 1 second). This average must meet the MIN/MAX requirements in Table 48. Additionally, VREF(t) can temporarily deviate from VREF(DC) by no more than ±1%VDD. VREF(t) cannot track noise on VDDQ or VDDCA if doing so would force VREF outside these specifications.

Figure 56: VREF DC Tolerance and VREF AC Noise Limits



The voltage levels for setup and hold time measurements $V_{IH}(AC)$, $V_{IH}(DC)$, $V_{IL}(AC)$, and $V_{IL}(DC)$ are dependent on VREF.

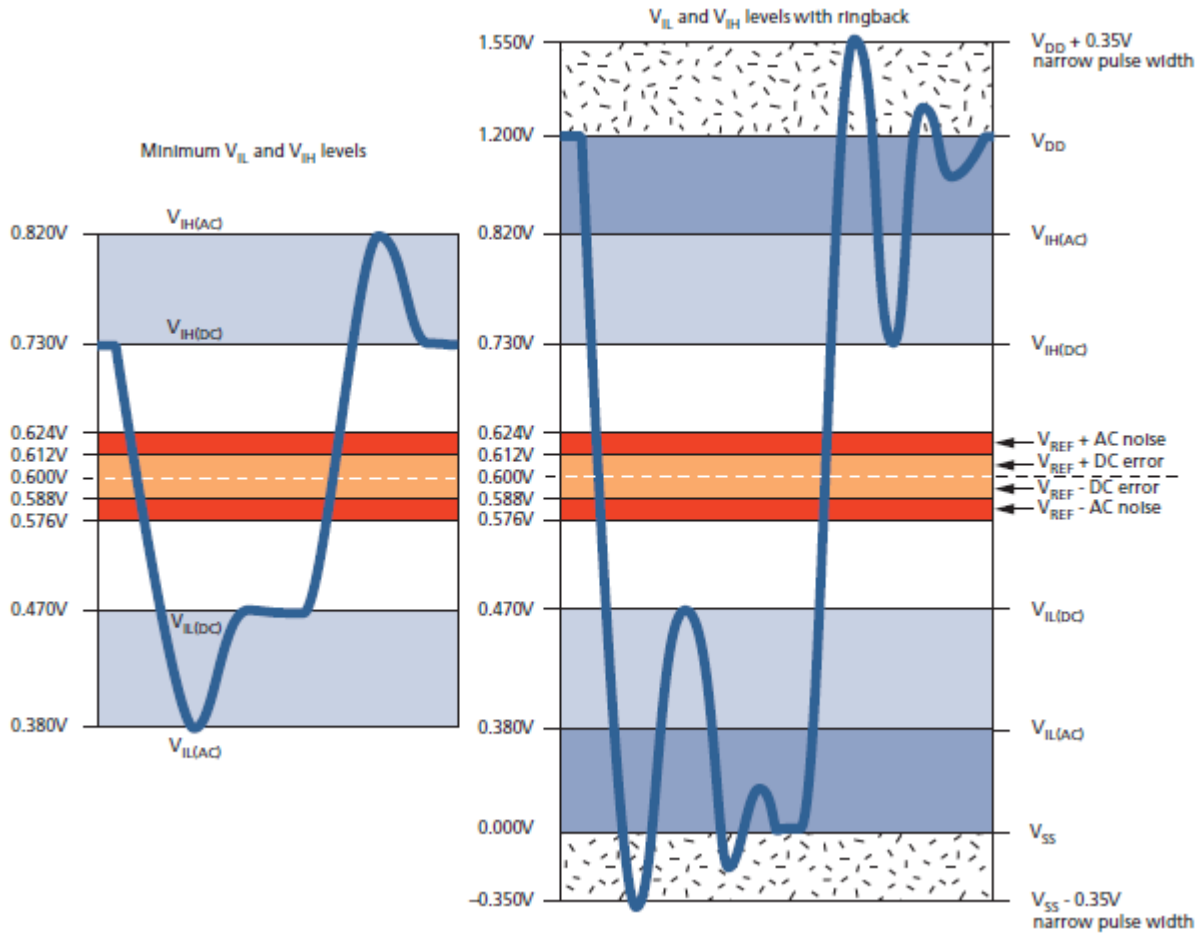
VREF DC variations affect the absolute voltage a signal must reach to achieve a valid HIGH or LOW, as well as the time from which setup and hold times are measured. When VREF is outside the specified levels, devices will function correctly with appropriate timing deratings as long as:

- VREF is maintained between $0.44 \times V_{DDQ}$ (or V_{DDCA}) and $0.56 \times V_{DDQ}$ (or V_{DDCA}), and
- the controller achieves the required single-ended AC and DC input levels from instantaneous VREF (see Table).

System timing and voltage budgets must account for VREF deviations outside this range. The setup/hold specification and derating values must include time and voltage associated with VREF AC noise. Timing and voltage effects due to AC noise on VREF up to the specified limit ($\pm 1\%V_{DD}$) are included in LPDDR2 timings and their associated deratings.

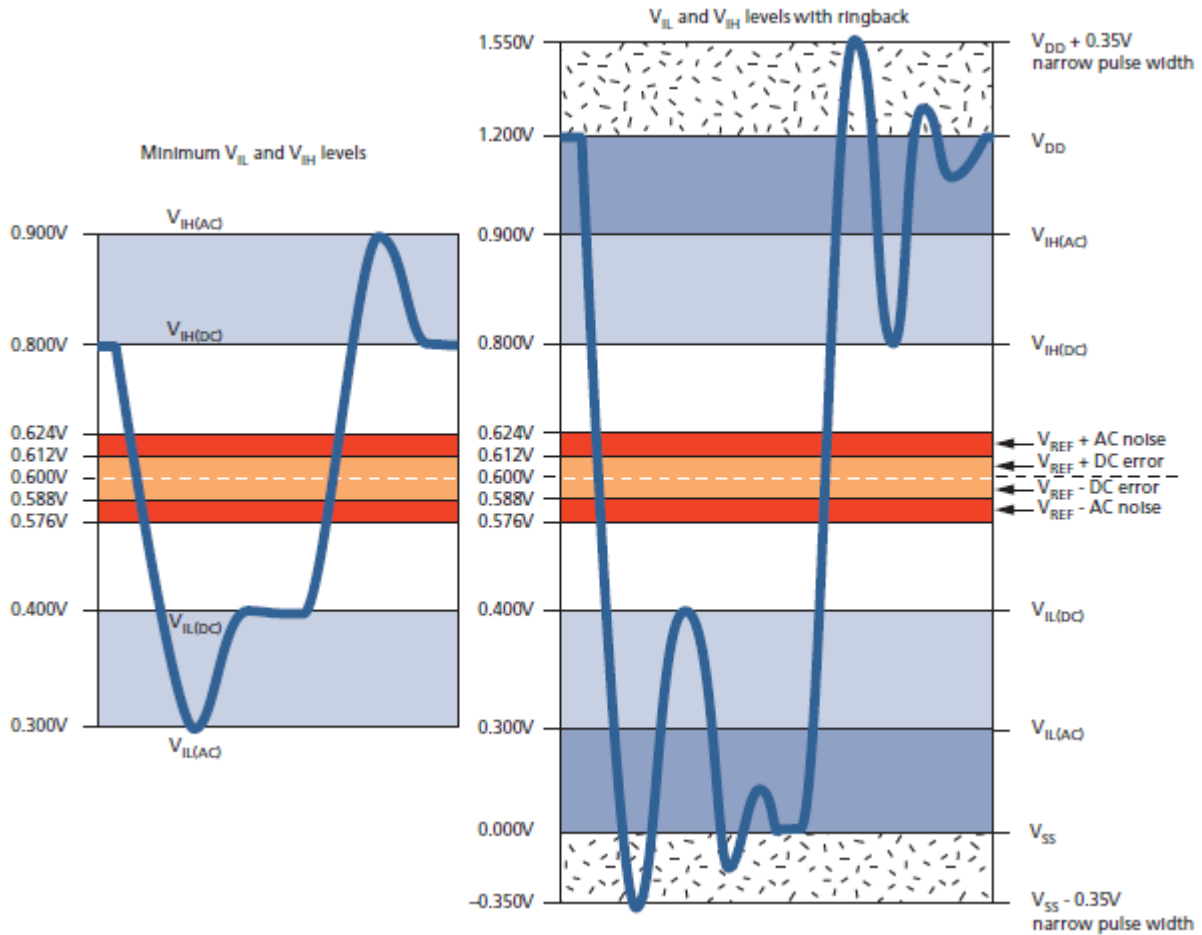
Input Signal

Figure 57: LPDDR2-466 to LPDDR2-800 Input Signal



Notes : 1. Numbers reflect typical values.

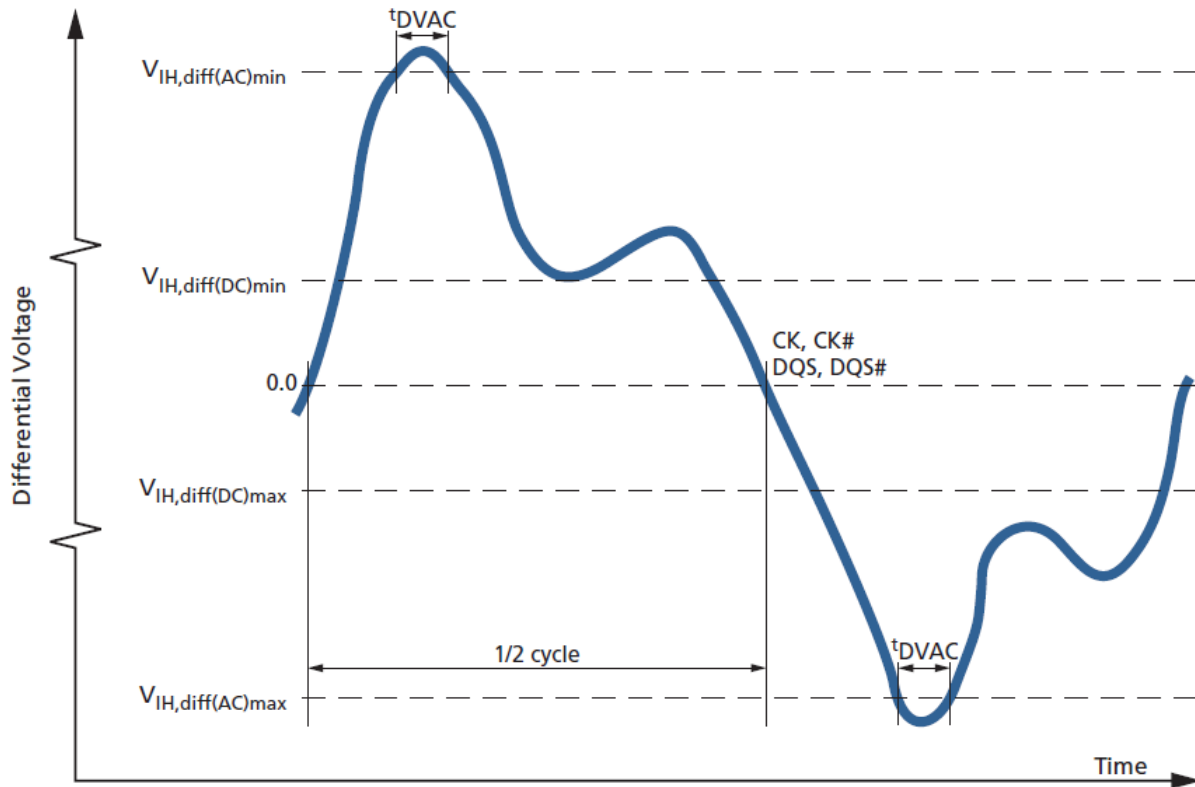
2. For CA[9:0], CK, CK#, and CS# V_{DD} stands for V_{DDCA}. For DQ, DM, DQS, and DQS#, V_{DD} stands for V_{DDQ}.
3. For CA[9:0], CK, CK#, and CS# V_{SS} stands for V_{SSCA}. For DQ, DM, DQS, and DQS#, V_{SS} stands for V_{SSQ}.

Figure 58: LPDDR2-200 to LPDDR2-400 Input Signal


Notes : 1. Numbers reflect typical values.

2. For CA[9:0], CK, CK#, and CS# V_{DD} stands for V_{DDCA} . For DQ, DM, DQS, and DQS#, V_{DD} stands for V_{DDQ} .

3. For CA[9:0], CK, CK#, and CS# V_{SS} stands for V_{SSCA} . For DQ, DM, DQS, and DQS#, V_{SS} stands for V_{SSQ} .

Figure 59: Differential AC Swing Time and tDVAC

Table 51: Differential AC and DC Input Levels

For CK and CK#, $V_{REF} = V_{REFCA}(DC)$; For DQS and DQS# $V_{REF} = V_{REFDQ}(DC)$

| Symbol | Parameter | LPDDR2-800 to LPDDR2-466 | | LPDDR2-400 to LPDDR2-200 | | Unit | notes |
|-------------------|----------------------------|-----------------------------------|-----------------------------------|-----------------------------------|-----------------------------------|------|-------|
| | | Min | Max | Min | Max | | |
| $V_{IH,diff}(AC)$ | Differential input HIGH AC | $2 \times (V_{IH}(AC) - V_{REF})$ | note1 | $2 \times (V_{IH}(AC) - V_{REF})$ | note1 | V | 2 |
| $V_{IL,diff}(AC)$ | Differential input LOW AC | note 1 | $2 \times (V_{IH}(AC) - V_{REF})$ | note 1 | $2 \times (V_{REF} - V_{IL}(AC))$ | V | 2 |
| $V_{IH,diff}(DC)$ | Differential input HIGH | $2 \times (V_{IH}(DC) - V_{REF})$ | note 1 | $2 \times (V_{IH}(DC) - V_{REF})$ | note 1 | V | 3 |
| $V_{IL,diff}(DC)$ | Differential input LOW | note1 | $2 \times (V_{REF} - V_{IL}(DC))$ | note1 | $2 \times (V_{REF} - V_{IL}(DC))$ | V | 3 |

- Notes :
1. These values are not defined, however the single-ended signals CK, CK#, DQS, and DQS# must be within the respective limits ($V_{IH}(DC)_{max}$, $V_{IL}(DC)_{min}$) for single-ended signals and must comply with the specified limitations for overshoot and undershoot (see Figure 65).
 2. For CK and CK#, use $V_{IH}/V_{IL}(AC)$ of CA and V_{REFCA} ; for DQS and DQS#, use $V_{IH}/V_{IL}(AC)$ of DQ and V_{REFDQ} . If a reduced AC HIGH or AC LOW is used for a signal group, the reduced voltage level also applies.
 3. Used to define a differential signal slew rate.

Table 52: CK/CK# and DQS/DQS# Time Requirements Before Ringback (t_{DVAC})

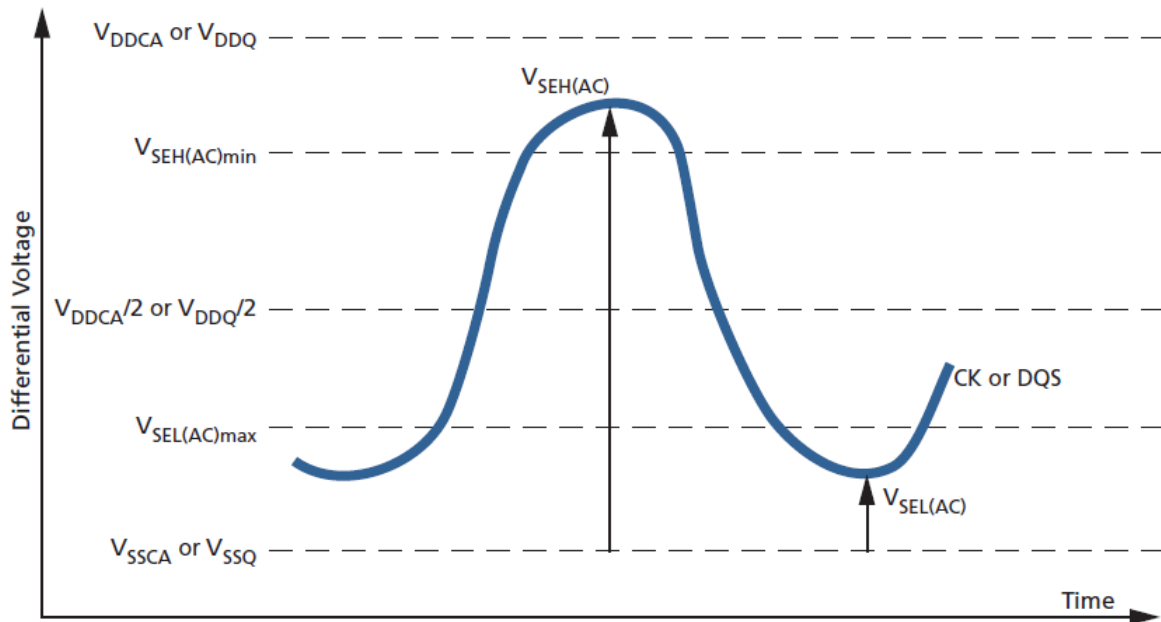
| Slew Rate (V/ns) | $t_{DVAC}(ps)$ at $V_{IH}/V_{ILdiff}(AC) = 440mV$ | | $t_{DVAC}(ps)$ at $V_{IH}/V_{ILdiff}(AC) = 600mV$ | |
|------------------|---|--|---|--|
| | Min | | Min | |
| >4.0 | 175 | | 75 | |
| 4.0 | 170 | | 57 | |
| 3.0 | 167 | | 50 | |
| 2.0 | 163 | | 38 | |
| 1.8 | 162 | | 34 | |
| 1.6 | 161 | | 29 | |
| 1.4 | 159 | | 22 | |
| 1.2 | 155 | | 13 | |
| 1.0 | 150 | | 0 | |
| <1.0 | 150 | | 0 | |

Single-Ended Requirements for Differential Signals

Each individual component of a differential signal(CK, CK#, DQS, and DQS#) must also comply with certain requirements for single-ended signals.

CK and CK# must meet $V_{SEH}(AC)_{min}/V_{SEL}(AC)_{max}$ in every half cycle. DQS, DQS# must meet $V_{SEH}(AC)_{min}/V_{SEL}(AC)_{max}$ in every half cycle preceding and following a valid transition.

The applicable AC levels for CA and DQ differ by speed bin.

Figure 60: Single-Ended Requirements for Differential Signals


Note that while CA and DQ signal requirements are referenced to VREF, the single-ended components of differential signals also have a requirement with respect to VDDQ/2 for DQS, and VDDCA/2 for CK.

The transition of single-ended signals through the AC levels is used to measure setup time. For single-ended components of differential signals, the requirement to reach VSEL(AC)max or VSEH(AC)min has no bearing on timing. This requirement does, however, add a restriction on the common mode characteristics of these signals (see Table 48) for CK/CK# single-ended requirements, and Table 48 for DQ and DQM single-ended requirements).

Table 53: Single-Ended Levels for CK, CK#, DQS, DQS#

| Symbol | Parameter | LPDDR2-800 to LPDDR2-466 | | LPDDR2-400 to LPDDR2-200 | | Unit | notes |
|----------|-------------------------------------|--------------------------|-----------------|--------------------------|-----------------|------|-------|
| | | Min | Max | Min | Max | | |
| VSEH(AC) | Single-ended HIGH level for strobes | (VDDQ/2)+0.220 | note1 | (VDDQ/2)+0.300 | note1 | V | 2,3 |
| | Single-ended HIGH level for CK, CK# | (VDDCA/2)+0.220 | note1 | (VDDCA/2)+0.300 | note1 | V | 2,3 |
| VSEL(AC) | Single-ended LOW level for strobes | note1 | (VDDQ/2)-0.220 | note1 | (VDDQ/2)+0.300 | V | 2,3 |
| | Single-ended LOW level for CK, CK# | note1 | (VDDCA/2)-0.220 | note1 | (VDDCA/2)+0.300 | V | 2,3 |

Notes : 1. These values are not defined, however, the single-ended signals CK, CK#, DQS0, DQS#0, DQS1, DQS#1, DQS2, DQS#2, DQS3, DQS#3 must be within the respective limits (VIH(DC)max/ VIL(DC)min) for single-ended signals, and must comply with the specified limitations for overshoot and undershoot (see Figure 65).

2. For CK and CK#, use VSEH/VSEL(AC) of CA; for strobes (DQS[3:0] and DQS#[3:0]), use VIH/VIL(AC) of DQ.

3. VIH(AC) and VIL(AC) for DQ are based on VREFDQ; VSEH(AC) and VSEL(AC) for CA are based on VREFCA.

If a reduced AC HIGH or AC LOW is used for a signal group, the reduced level applies.

Differential Input Crosspoint Voltage

To ensure tight setup and hold times as well as output skew parameters with respect to clock and strobe, each crosspoint voltage of differential input signals (CK, CK#, DQS, and DQS#) must meet the specifications in Table 53.

The differential input crosspoint voltage (V_{IX}) is measured from the actual crosspoint of the true signal and its complement to the midlevel between V_{DD} and V_{SS} .

Figure 61: V_{IX} Definition

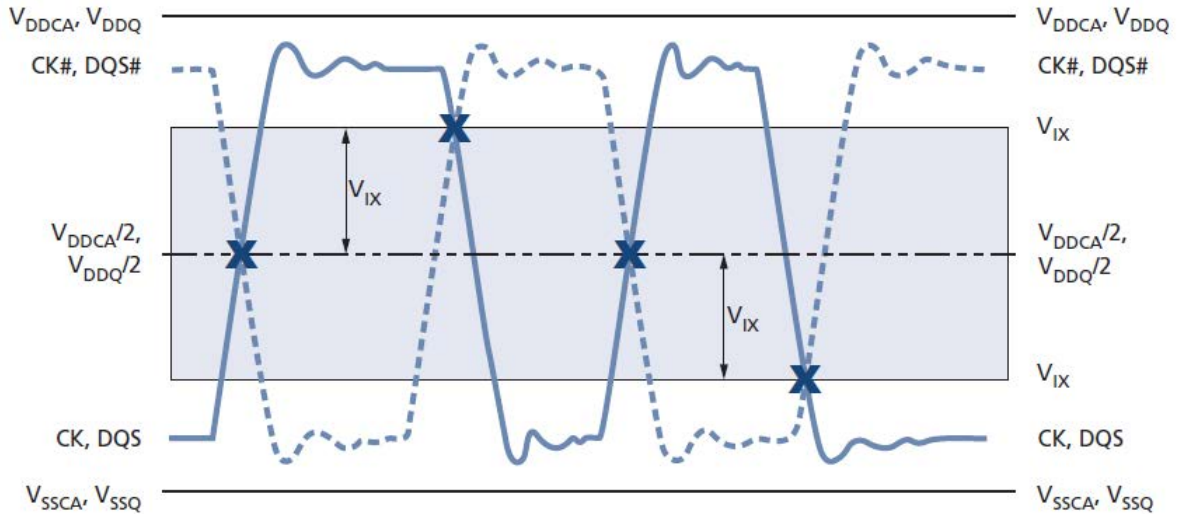


Table 54: Crosspoint Voltage for Differential Input Signals (CK, CK#, DQS, DQS#)

| Symbol | Parameter | LPDDR2-800 to LPDDR2-200 | | Unit | notes |
|----------------|--|--------------------------|-----|------|-------|
| | | Min | Max | | |
| $V_{IXCA(AC)}$ | Differential input cross point voltage relative to $V_{DDCA}/2$ for CK and CK# | -120 | 120 | mV | 1,2 |
| $V_{IXDQ(AC)}$ | Differential input cross point voltage relative to $V_{DDQ}/2$ for DQS and DQ# | -120 | 120 | mV | 1,2 |

Notes : 1. The typical value of $V_{IX(AC)}$ is expected to be about $0.5 \times V_{DD}$ of the transmitting device, and it is expected to track variations in V_{DD} . $V_{IX(AC)}$ indicates the voltage at which differential input signals must cross.

2. For CK and CK#, $V_{REF} = V_{REFCA(DC)}$. For DQS and DQS#, $V_{REF} = V_{REFDQ(DC)}$.

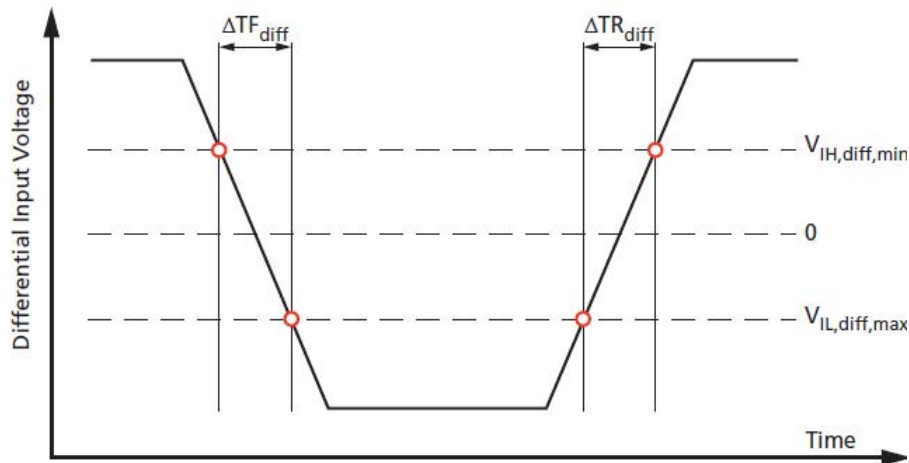
Input Slew Rate

Table 55: Differential Input Slew Rate Definition

| Description | Measured | | Defined by |
|--|-------------------|-------------------|--|
| | From | To | |
| Differential input slew rate for rising edge (CK/CK# and DQS/DQS#) | $V_{IL,diff,max}$ | $V_{IH,diff,min}$ | $[V_{IH,diff,min} - V_{IL,diff,max}] / \Delta TR_{diff}$ |
| Differential input slew rate for falling edge (CK/CK# and DQS/DQS#) | $V_{IH,diff,min}$ | $V_{IL,diff,max}$ | $[V_{IH,diff,min} - V_{IL,diff,max}] / \Delta TF_{diff}$ |

Note : 1. The differential signals (CK/CK# and DQS/DQS#) must be linear between these thresholds.

Figure 62: Differential Input Slew Rate Definition for CK, CK#, DQS, and DQS#



Output Characteristics and Operating Conditions

Table 56: Single-Ended AC and DC Output Levels

| Symbol | Parameter | Value | Unit | Notes |
|--------------|--|----------------------|------|-------|
| $V_{OH(AC)}$ | AC output HIGH measurement level(for output slew rate) | $V_{REF}+0.12$ | V | |
| $V_{OL(AC)}$ | AC output LOW measurement level(for output slew rate) | $V_{REF}-0.12$ | V | |
| $V_{OH(DC)}$ | DC output HIGH measurement level(for I-V curve linearity) | $0.9 \times V_{DDQ}$ | V | 1 |
| $V_{OL(DC)}$ | DC output LOW measurement level(for I-V curve linearity) | $0.1 \times V_{DDQ}$ | V | 2 |
| I_{oz} | Output leakage current (DQ, DM, DQS, DQS#); DQ, DQS, DQS# are disabled; $0V \leq V_{OUT} \leq V_{DDQ}$ | MIN | -5 | uA |
| | | MAX | +5 | uA |
| MMpupd | Delta output impedance between pull-up and pull-down for DQ/DM | MIN | -15 | % |
| | | MAX | +15 | % |

Notes : 1. $I_{OH} = -0.1mA$
2. $I_{OL} = 0.1mA$

Table 57: Differential AC and DC Output Levels

| Symbol | Parameter | Value | Unit |
|------------------|--|-----------------------|------|
| $V_{OHdiff(AC)}$ | AC differential output HIGH measurement level(for output SR) | $+0.2 \times V_{DDQ}$ | V |
| $V_{OLdiff(AC)}$ | AC differential output LOW measurement level(for output SR) | $-0.2 \times V_{DDQ}$ | V |

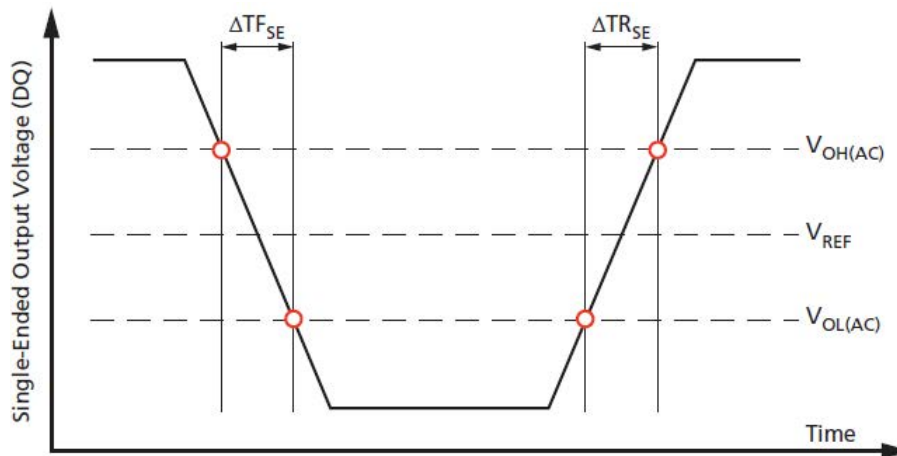
Single-Ended Output Slew Rate

With the reference load for timing measurements, the output slew rate for falling and rising edges is defined and measured between $V_{OL(AC)}$ and $V_{OH(AC)}$ for single-ended signals.

Table 58: Single-Ended Output Slew Rate Definition

| Description | Measured | | Defined by |
|--|--------------|--------------|--|
| | From | To | |
| Single-ended output slew rate for rising edge | $V_{OL(AC)}$ | $V_{OH(AC)}$ | $[V_{OH(AC)} - V_{OL(AC)}] / \Delta TR_{SE}$ |
| Single-ended output slew rate for falling edge | $V_{OH(AC)}$ | $V_{OL(AC)}$ | $[V_{OH(AC)} - V_{OL(AC)}] / \Delta TF_{SE}$ |

Note : 1. Output slew rate is verified by design and characterization and may not be subject to production testing.

Figure 63: Single-Ended Output Slew Rate Definition

Table 59: Single-Ended Output Slew Rate

Notes 1–5 apply to all parameters conditions

| Parameter | Symbol | Value | | Unit |
|---|------------|-------|-----|------|
| | | Min | Max | |
| single-ended output slew rate(output impedance= $40\Omega \pm 30\%$) | SRQ_{SE} | 1.5 | 3.5 | V/ns |
| single-ended output slew rate(output impedance= $60\Omega \pm 30\%$) | SRQ_{SE} | 1.0 | 2.5 | V/ns |
| Output slew-rate-matching ratio(pull-up to pull-down) | | 0.7 | 1.4 | - |

Notes : 1. Definitions: SR = slew rate; Q = output (similar to DQ = data-in, data-out); SE = single-ended signals.

2. Measured with output reference load.

3. The ratio of pull-up to pull-down slew rate is specified for the same temperature and voltage over the entire temperature and voltage range. For a given output, the ratio represents the maximum difference between pull-up and pull-down drivers due to process variation.
4. The output slew rate for falling and rising edges is defined and measured between VOL(AC) and VOH(AC).
5. Slew rates are measured under typical simultaneous switching output (SSO) conditions, with one-half of DQ signals per data byte driving HIGH and one-half of DQ signals per data byte driving LOW.

Differential Output Slew Rate

With the reference load for timing measurements, the output slew rate for falling and rising edges is defined and measured between VOL,diff(AC) and VOH,diff(AC) for differential signals.

Table 60: Differential Output Slew Rate Definition

| Description | Measured | | Defined by |
|--|--------------|--------------|--|
| | From | To | |
| Differential output slew rate for rising edge | VOL,diff(AC) | VOH,diff(AC) | $[VOH, diff(AC) - VOL, diff(AC)] / \Delta TR_{diff}$ |
| Differential output slew rate for falling edge | VOH,diff(AC) | VOL,diff(AC) | $[VOH, diff(AC) - VOL, diff(AC)] / \Delta TF_{diff}$ |

Note : 1. Output slew rate is verified by design and characterization and may not be subject to production testing.

Figure 64: Differential Output Slew Rate Definition

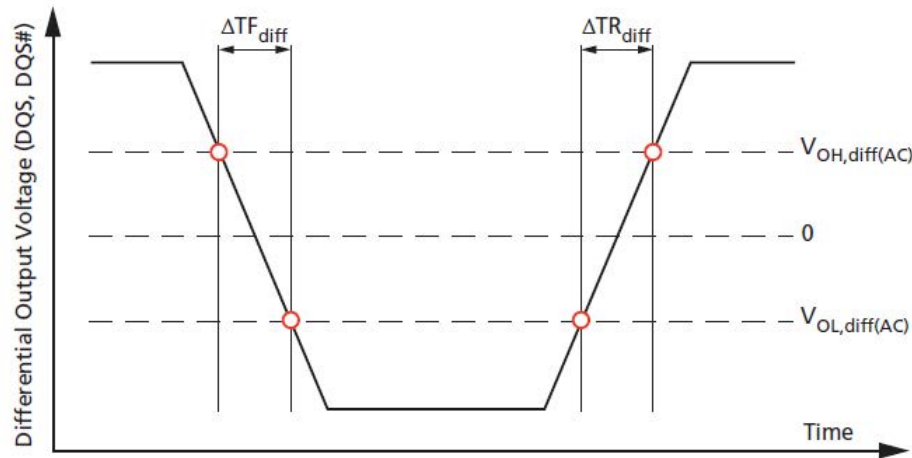


Table 61: Differential Output Slew Rate

| Parameter | Symbol | Value | | Unit |
|---|---------|-------|-----|------|
| | | Min | Max | |
| Differential output slew rate(output impedance=40Ω±30%) | SRQdiff | 3.0 | 7.0 | V/ns |

Table 62: Differential Output Slew Rate (Continued)

| Parameter | Symbol | Value | | Unit |
|---|---------|-------|-----|------|
| | | Min | Max | |
| Differential output slew rate(output impedance=60Ω±30%) | SRQdiff | 2.0 | 5.0 | V/ns |

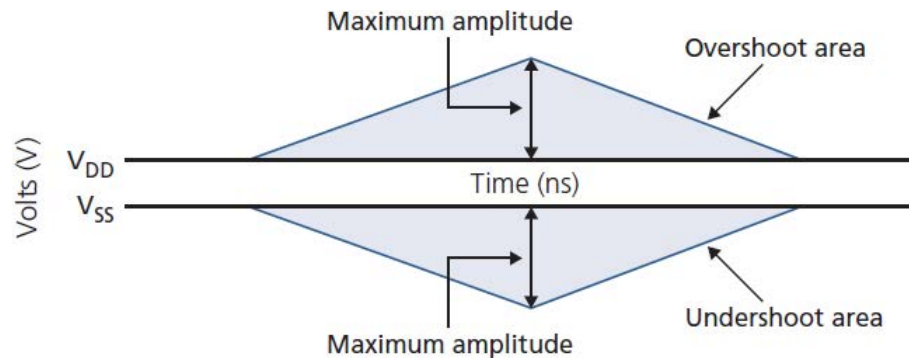
- Notes :
1. Definitions: SR = slew rate; Q = output (similar to DQ = data-in, data-out); SE = single-ended signals.
 2. Measured with output reference load.
 3. The output slew rate for falling and rising edges is defined and measured between $V_{OL(AC)}$ and $V_{OH(AC)}$.
 4. Slew rates are measured under typical simultaneous switching output (SSO) conditions, with one-half of DQ signals per data byte driving HIGH and one-half of DQ signals per data byte driving LOW.

Table 63: AC Overshoot/Undershoot Specification

Applies for CA[9:0], CS#, CKE, CK, CK#, DQ, DQS, DQS#, DM

| Parameter | 800 | 667 | 533 | 400 | 333 | Unit |
|---|------|------|------|------|------|------|
| Maximum peak amplitude provided for overshoot area | 0.35 | 0.35 | 0.35 | 0.35 | 0.35 | V |
| Maximum peak amplitude provided for undershoot area | 0.35 | 0.35 | 0.35 | 0.35 | 0.35 | V |
| Maximum area above V_{DD} | 0.20 | 0.24 | 0.30 | 0.40 | 0.48 | V/ns |
| Maximum area below V_{SS} | 0.20 | 0.24 | 0.30 | 0.40 | 0.48 | V/ns |

- Notes :
1. V_{DD} stands for V_{DDCA} for CA[9:0], CK, CK#, CS#, and CKE. V_{DD} stands for V_{DDQ} for DQ, DM, DQS, and DQS#.
 2. V_{SS} stands for V_{SSCA} for CA[9:0], CK, CK#, CS#, and CKE. V_{SS} stands for V_{SSQ} for DQ, DM, DQS, and DQS#.

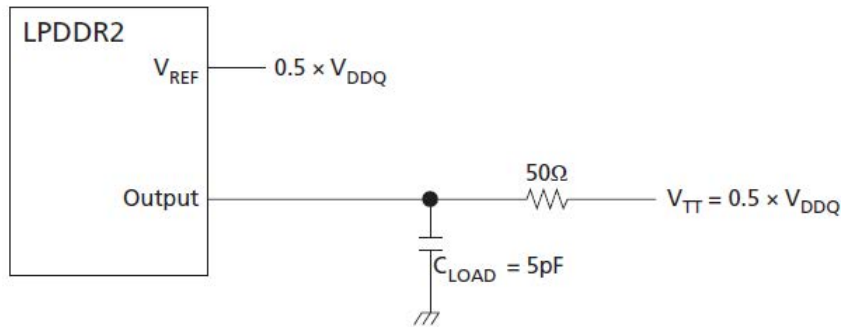
Figure 65: Overshoot and Undershoot Definition


- Notes :
1. V_{DD} stands for V_{DDCA} for CA[9:0], CK, CK#, CS#, and CKE. V_{DD} stands for V_{DDQ} for DQ, DM, DQS, and DQS#.
 2. V_{SS} stands for V_{SSCA} for CA[9:0], CK, CK#, CS#, and CKE. V_{SS} stands for V_{SSQ} for DQ, DM, DQS, and DQS#.

HSUL_12 Driver Output Timing Reference Load

The timing reference loads are not intended as a precise representation of any particular system environment or a depiction of the actual load presented by a production tester. System designers should use IBIS or other simulation tools to correlate the timing reference load to a system environment. Manufacturers correlate to their production test conditions, generally with one or more coaxial transmission lines terminated at the tester electronics.

Figure 66: HSUL_12 Driver Output Reference Load for Timing and Slew Rate



Note : 1. All output timing parameter values (t_{DQSCK} , t_{DQSQ} , t_{QHS} , t_{HZ} , t_{RPRE} etc.) are reported with respect to this reference load. This reference load is also used to report slew rate.

Output Driver Impedance

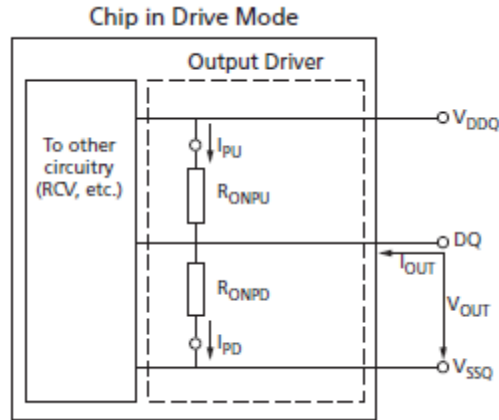
Output driver impedance is selected by a mode register during initialization. To achieve tighter tolerances, ZQ calibration is required. Output specifications refer to the default output drive unless specifically stated otherwise. The output driver impedance R_{ON} is defined by the value of the external reference resistor R_{ZQ} as follows:

$$R_{ONPU} = \frac{V_{DDQ} - V_{OUT}}{ABS(I_{OUT})}$$

When R_{ONPD} is turned off.

$$R_{ONPD} = \frac{V_{OUT}}{ABS(I_{OUT})}$$

When R_{ONPU} is turned off.

Figure 67: Output Driver

Output Driver Impedance Characteristics with ZQ Calibration

Output driver impedance is defined by the value of the external reference resistor RZQ. Typical RZQ is 240 ohms.

Table 67: Output Driver DC Electrical Characteristics with ZQ Calibration

Notes 1–4 apply to all parameters and conditions

| RONnom | Resistor | Vout | Min | Typ | Max | Unit | notes |
|--|----------|------------|--------|------|--------|-------|-------|
| 34.3Ω | RON34PD | 0.5 × VDDQ | 0.85 | 1.00 | 1.15 | Rzq/7 | |
| | RON34PU | 0.5 × VDDQ | 0.85 | 1.00 | 1.15 | Rzq/7 | |
| 40.0Ω | RON40PD | 0.5 × VDDQ | 0.85 | 1.00 | 1.15 | Rzq/6 | |
| | RON40PU | 0.5 × VDDQ | 0.85 | 1.00 | 1.15 | Rzq/6 | |
| 48.0Ω | RON48PD | 0.5 × VDDQ | 0.85 | 1.00 | 1.15 | Rzq/5 | |
| | RON48PU | 0.5 × VDDQ | 0.85 | 1.00 | 1.15 | Rzq/5 | |
| 60.0Ω | RON60PD | 0.5 × VDDQ | 0.85 | 1.00 | 1.15 | Rzq/4 | |
| | RON60PU | 0.5 × VDDQ | 0.85 | 1.00 | 1.15 | Rzq/4 | |
| 80.0Ω | RON80PD | 0.5 × VDDQ | 0.85 | 1.00 | 1.15 | Rzq/3 | |
| | RON80PU | 0.5 × VDDQ | 0.85 | 1.00 | 1.15 | Rzq/3 | |
| 120.0Ω | RON120PD | 0.5 × VDDQ | 0.85 | 1.00 | 1.15 | Rzq/2 | |
| | RON120PU | 0.5 × VDDQ | 0.85 | 1.00 | 1.15 | Rzq/2 | |
| Mismatch between pull-up and pull-down | MMpUPD | | -15.00 | | +15.00 | % | 5 |

Notes : 1. Applies across entire operating temperature range after calibration.

2. RZQ=240Ω

3. The tolerance limits are specified after calibration, with fixed voltage and temperature.

4. For behavior of the tolerance limits if temperature or voltage changes after calibration.

5. Pull-down and pull-up output driver impedances should be calibrated at 0.5 × VDDQ.

6. Measurement definition for mismatch between pull-up and pull-down, MMpUPD:

Measure RONPU and RONPD, both at 0.5 × VDDQ:

$$\text{MMpUPD} = \frac{\text{RONPU} - \text{RONPD}}{\text{RON,nom}} \times 100$$

For example, with MMpUPD (MAX) = 15% and RONPD = 0.85, RONPU must be less than 1.0.

Output Driver Temperature and Voltage Sensitivity

If temperature and/or voltage change after calibration, the tolerance limits widen.

Table 68: Output Driver Sensitivity Definition

| Resistor | V _{OUT} | Min | Max | Unit |
|-------------------|------------------------|--|---|------|
| R _{ONPD} | 0.5 × V _{DDQ} | 85-(dR _{OND} T· ΔT)-(dR _{OND} V· ΔV) | 115-(dR _{OND} T· ΔT)-(dR _{OND} V· ΔV) | % |
| R _{ONPU} | | | | |

Notes : 1. ΔT = T - T (at calibration). ΔV = V - V (at calibration).

2. dR_{OND}T and dR_{OND}V are not subject to production testing; they are verified by design and characterization.

Table 69: Output Driver Temperature and Voltage Sensitivity

| Symbol | Parameter | V _{OUT} | Min | Max | Unit |
|-------------------|---|------------------------|------|------|------|
| R _{ONPD} | R _{ON} temperature sensitivity | 0.5 × V _{DDQ} | 0.00 | 0.75 | %/°C |
| R _{ONPU} | R _{ON} voltage sensitivity | 0.5 × V _{DDQ} | 0.00 | 0.20 | %/mV |

Output Impedance Characteristics Without ZQ Calibration

Output driver impedance is defined by design and characterization as the default setting.

Table 70: Output Driver DC Electrical Characteristics Without ZQ Calibration

| R _{ONnom} | Resistor | V _{OUT} | Min | Typ | Max | Unit |
|--------------------|----------------------|------------------------|------|------|------|--------------------|
| 34.3Ω | R _{ON34PD} | 0.5 × V _{DDQ} | 0.70 | 1.00 | 1.30 | R _{ZQ} /7 |
| | R _{ON34PU} | 0.5 × V _{DDQ} | 0.70 | 1.00 | 1.30 | R _{ZQ} /7 |
| 40.0Ω | R _{ON40PD} | 0.5 × V _{DDQ} | 0.70 | 1.00 | 1.30 | R _{ZQ} /6 |
| | R _{ON40PU} | 0.5 × V _{DDQ} | 0.70 | 1.00 | 1.30 | R _{ZQ} /6 |
| 48.0Ω | R _{ON48PD} | 0.5 × V _{DDQ} | 0.70 | 1.00 | 1.30 | R _{ZQ} /5 |
| | R _{ON48PU} | 0.5 × V _{DDQ} | 0.70 | 1.00 | 1.30 | R _{ZQ} /5 |
| 60.0Ω | R _{ON60PD} | 0.5 × V _{DDQ} | 0.70 | 1.00 | 1.30 | R _{ZQ} /4 |
| | R _{ON60PU} | 0.5 × V _{DDQ} | 0.70 | 1.00 | 1.30 | R _{ZQ} /4 |
| 80.0Ω | R _{ON80PD} | 0.5 × V _{DDQ} | 0.70 | 1.00 | 1.30 | R _{ZQ} /3 |
| | R _{ON80PU} | 0.5 × V _{DDQ} | 0.70 | 1.00 | 1.30 | R _{ZQ} /3 |
| 120.0Ω | R _{ON120PD} | 0.5 × V _{DDQ} | 0.70 | 1.00 | 1.30 | R _{ZQ} /2 |
| | R _{ON120PU} | 0.5 × V _{DDQ} | 0.70 | 1.00 | 1.30 | R _{ZQ} /2 |

Notes : 1. Applies across entire operating temperature range without calibration.

2. R_{ZQ}=240Ω

Table 71: I-V Curves

| Voltage | Ron=240Ω(Rzq) | | | | | | | |
|---------|-----------------------------|---------|------------------|---------|-----------------------------|---------|------------------|---------|
| | Pull-Down | | | | Pull-Up | | | |
| | Current(mA) / Ron(ohms) | | | | Current(mA) / Ron(ohms) | | | |
| | Default Value after ZQRESET | | With Calibration | | Default Value after ZQRESET | | With Calibration | |
| | Min(mA) | Max(mA) | Min(mA) | Max(mA) | Min(mA) | Max(mA) | Min(mA) | Max(mA) |
| 0.00 | 0.00 | 0.00 | 0.00 | 0.00 | 0.00 | 0.00 | 0.00 | 0.00 |
| 0.05 | 0.19 | 0.32 | 0.21 | 0.26 | -0.19 | -0.32 | -0.21 | -0.26 |
| 0.10 | 0.38 | 0.64 | 0.40 | 0.53 | -0.38 | -0.64 | -0.40 | -0.53 |
| 0.15 | 0.56 | 0.94 | 0.60 | 0.78 | -0.56 | -0.94 | -0.60 | -0.78 |
| 0.20 | 0.74 | 1.26 | 0.79 | 1.04 | -0.74 | -1.26 | -0.79 | -1.04 |
| 0.25 | 0.92 | 1.57 | 0.98 | 1.29 | -0.92 | -1.57 | -0.98 | -1.29 |
| 0.30 | 1.08 | 1.86 | 1.17 | 1.53 | -1.08 | -1.86 | -1.17 | -1.53 |
| 0.35 | 1.25 | 2.17 | 1.35 | 1.79 | -1.25 | -2.17 | -1.35 | -1.79 |
| 0.40 | 1.40 | 2.46 | 1.52 | 2.03 | -1.40 | -2.46 | -1.52 | -2.03 |
| 0.45 | 1.54 | 2.74 | 1.69 | 2.26 | -1.54 | -2.74 | -1.69 | -2.26 |
| 0.50 | 1.68 | 3.02 | 1.86 | 2.49 | -1.68 | -3.02 | -1.86 | -2.49 |
| 0.55 | 1.81 | 3.30 | 2.02 | 2.72 | -1.81 | -3.30 | -2.02 | -2.72 |
| 0.60 | 1.92 | 3.57 | 2.17 | 2.94 | -1.92 | -3.57 | -2.17 | -2.94 |
| 0.65 | 2.02 | 3.83 | 2.32 | 3.15 | -2.02 | -3.83 | -2.32 | -3.15 |
| 0.70 | 2.11 | 4.08 | 2.46 | 3.36 | -2.11 | -4.08 | -2.46 | -3.36 |
| 0.75 | 2.19 | 4.31 | 2.58 | 3.55 | -2.19 | -4.31 | -2.58 | -3.55 |
| 0.80 | 2.25 | 4.54 | 2.70 | 3.74 | -2.25 | -4.54 | -2.70 | -3.74 |
| 0.85 | 2.30 | 4.74 | 2.81 | 3.91 | -2.30 | -4.74 | -2.81 | -3.91 |
| 0.90 | 2.34 | 4.92 | 2.89 | 4.05 | -2.34 | -4.92 | -2.89 | -4.05 |
| 0.95 | 2.37 | 5.08 | 2.97 | 4.23 | -2.37 | -5.08 | -2.97 | -4.23 |
| 1.00 | 2.41 | 5.20 | 3.04 | 4.33 | -2.41 | -5.20 | -3.04 | -4.33 |
| 1.05 | 2.43 | 5.31 | 3.09 | 4.44 | -2.43 | -5.31 | -3.09 | -4.44 |
| 1.10 | 2.46 | 5.41 | 3.14 | 4.52 | -2.46 | -5.41 | -3.14 | -4.52 |
| 1.15 | 2.48 | 5.48 | 3.19 | 4.59 | -2.48 | -5.48 | -3.19 | -4.59 |
| 1.20 | 2.50 | 5.55 | 3.23 | 4.65 | -2.50 | -5.55 | -3.23 | -4.65 |

Figure 68 : Output Impedance = 240 Ohms, I-V Curves After ZQRESET

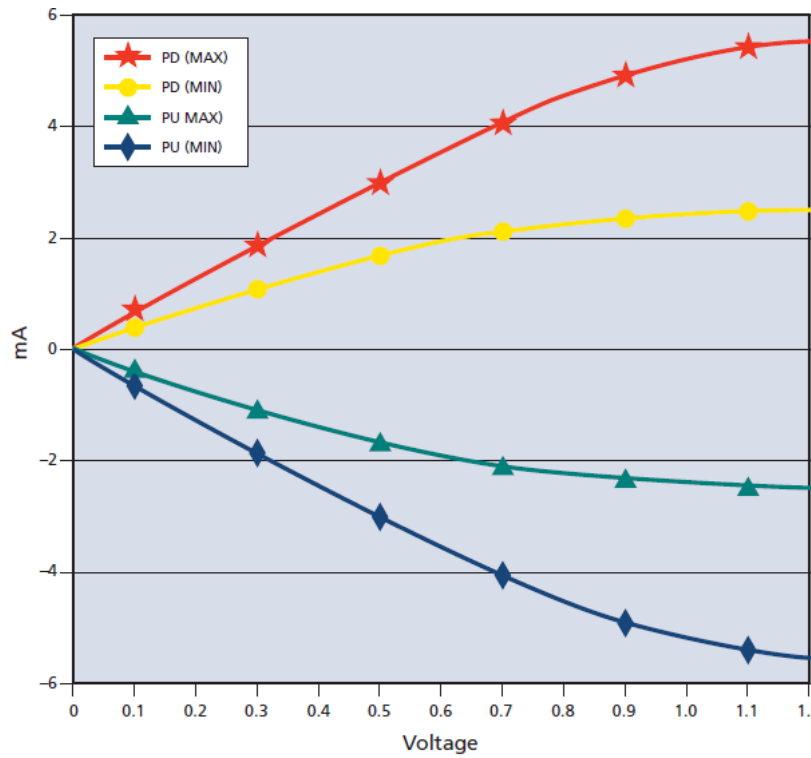
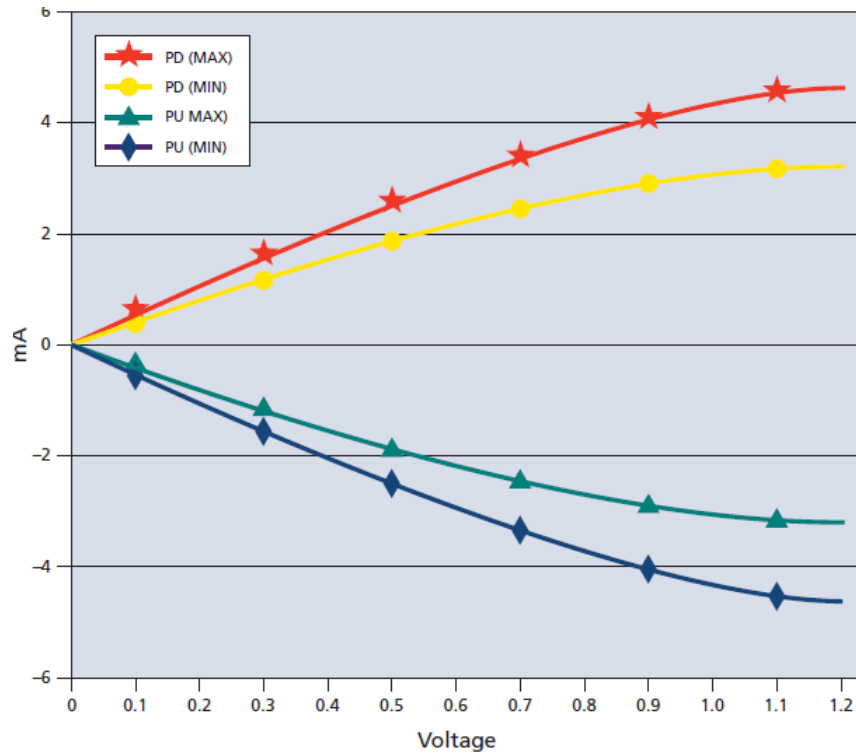


Figure 69: Output Impedance = 240 Ohms, I-V Curves After Calibration



Clock Specification

The specified clock jitter is a random jitter with Gaussian distribution. Input clocks violating minimum or maximum values may result in device malfunction.

Table 72: Definitions and Calculations

| Symbol | Description | Calculation | Notes |
|---------------------|---|--|-------|
| tCK(avg) and nCK | <p>The average clock period across any consecutive 200-cycle window. Each clock period is calculated from rising clock edge to rising clock edge.</p> <p>Unit tCK(avg) represents the actual clock average tCK (avg) of the input clock under operation. Unit nCK represents one clock cycle of the input clock, counting from actual clock edge to actual clock edge.</p> <p>tCK (avg) can change no more than ±1% within a 100clock cycle window, provided that all jitter and timing specifications are met.</p> | $tCK(avg) = \frac{\sum_{j=1}^N tCK_j}{N}$ <p>Where N = 200</p> | |
| tCK(abs) | The absolute clock period, as measured from one rising clock edge to the next consecutive rising clock edge. | | 1 |
| tCH(avg) | The average HIGH pulse width, as calculated across any 200 consecutive HIGH pulses. | $tCH(avg) = \frac{\sum_{j=1}^N tCH_j}{(N \times tCK(avg))}$ <p>Where N = 200</p> | |
| tJIT(per) | The single-period jitter defined as the largest deviation of any signal tCK from tCK(avg). | $tCL(avg) = \frac{\sum_{j=1}^N tCL_j}{(N \times tCK(avg))}$ <p>Where N = 200</p> | |
| tJIT(per), act | The actual clock jitter for a given system. | $tJIT(per) = \min/\max \text{ of } (tCK_i - tCK(avg))$ <p>Where i = 1 to 200</p> | |
| tJIT(per), allowed | The specified clock period jitter allowance. | | |
| tJIT(CC) | The absolute difference in clock periods between two consecutive clock cycles. tJIT(cc) defines the cycle-to-cycle jitter. | $tJIT(cc) = \max \text{ of } (tCK_{i+1} - tCK_i)$ | 1 |
| tERR(nper) | The cumulative error across n multiple consecutive cycles from tCK(avg). | $tERR(nper) = \left(\sum_{j=i}^{i+n-1} tCK_j \right) - (N \times tCK(avg))$ | 1 |
| tERR(nper), act | The actual cumulative error over n cycles for a given system. | | |
| tERR(nper), allowed | The specified cumulative error allowance over n cycles. | | |
| tERR(nper), min | The minimum tERR(nper). | $tERR(nper),min = (1 + 0.68LN(n)) \times tJIT(per),min$ | 2 |

Table 73: Definitions and Calculations (Continued)

| Symbol | description | Calculation | Notes |
|-----------------|---|--|-------|
| tERR(nper), max | The maximum tERR(nper). | tERR(nper),max = (1 + 0.68LN(n)) × tJIT(per),max | 2 |
| tJIT(duty) | Defined with absolute and average specifications for tCH and tCL, respectively. | tJIT(duty),min = MIN((tCH(abs),min – tCH(avg),min), (tCL(abs),min – tCL(avg),min)) × tCK(avg) tJIT(duty),max = MAX((tCH(abs),max – tCH(avg),max), (tCL(abs),max – tCL(avg),max)) × tCK(avg) | |

Notes : 1. Not subject to production testing.

2. Using these equations, tERR(nper) tables can be generated for each tJIT(per),act value.

tCK(abs), tCH(abs), and tCL(abs)

These parameters are specified with their average values; however, the relationship between the average timing and the absolute instantaneous timing (defined in the following table) is applicable at all times.

Table 74: tCK(abs), tCH(abs), and tCL(abs) Definitions

| Parameter | Symbol | Minimum | Unit |
|---------------------------------|----------|--|----------|
| Absolute clock period | tCK(abs) | tCK(avg),min + tJIT(per),min | ps |
| Absolute clock HIGH pulse width | tCH(abs) | tCH(avg),min + tJIT(duty),min2/tCK(avg)min | tCK(avg) |
| Absolute clock LOW width | tCL(abs) | tCL(avg),min + tJIT(duty),min2/tCK(avg)min | tCK(avg) |

Notes : 1. tCK(avg),min is expressed in ps for this table.

2. tJIT(duty),min is a negative value.

Clock Period Jitter

LPDDR2 devices can tolerate some clock period jitter without core timing parameter derating. This section describes device timing requirements with clock period jitter (tJIT(per)) in excess of the values found in the ACTiming section. Calculating cycle time derating and clock cycle derating are also described.

Clock Period Jitter Effects on Core Timing Parameters

Core timing parameters (tRCD, tRP, tRTP, tWR, tWRA, tWTR, tRC, tRAS, tRRD, tFAW) extend across multiple clock cycles. Clock period jitter impacts these parameters when measured in numbers of clock cycles. Within the specification limits, the device is characterized and verified to support $t_{nPARAM} = RU[t_{PARAM}/t_{CK}(avg)]$. During device operation where clock jitter is outside specification limits, the number of clocks or tCK(avg), may need to be increased based on the values for each core timing parameter.

Cycle Time Derating for Core Timing Parameters

For a given number of clocks (tnPARAM), when tCK(avg) and tERR(tnPARAM),act exceed tERR(tnPARAM),allowed, cycle time derating may be required for core timing parameters.

$$\text{CycleTimeDerating} = \max\left\{\frac{t_{PARAM} + t_{ERR}(t_{nPARAM}),act - t_{ERR}(t_{nPARAM}),allowed}{t_{nPARAM}} - t_{CK}(avg), 0\right\}$$

Cycle time derating analysis should be conducted for each core timing parameter. The amount of cycle time derating required is the maximum of the cycle time deratings determined for each individual core timing parameter.

Clock Cycle Derating for Core Timing Parameters

For each core timing parameter and a given number of clocks (t_{nPARAM}), *clock cycle* derating should be specified with $t_{JIT(per)}$. For a given number of clocks (t_{nPARAM}), when $t_{CK(avg)}$ plus ($t_{ERR}(t_{nPARAM},act)$) exceed the supported cumulative $t_{ERR}(t_{nPARAM},allowed)$, derating is required. If the equation below results in a positive value for a core timing parameter (t_{CORE}), the required clock cycle derating will be that positive value (in clocks).

$$\text{ClockCycleDerating} = RU \left\{ \frac{t_{PARAM} + t_{ERR}(t_{nPARAM},act) - t_{ERR}(t_{nPARAM},allowed)}{t_{CK(avg)}} \right\} - t_{nPARAM}$$

Cycle-time derating analysis should be conducted for each core timing parameter.

Clock Jitter Effects on Command/Address Timing Parameters

Command/address timing parameters (t_{IS} , t_{IH} , t_{ISCKE} , t_{IHCKE} , t_{ISb} , t_{IHb} , t_{ISCKEb} , t_{IHCKEb}) are measured from a command / address signal (CKE, CS, or CA[9:0]) transition edge to its respective clock signal (CK/CK#) crossing. The specification values are not affected by the $t_{JIT(per)}$ applied, because the setup and hold times are relative to the clock signal crossing that latches the command/address. Regardless of clock jitter values, these values must be met.

Clock Jitter Effects on READ Timing Parameters

tRPRE

When the device is operated with input clock jitter, t_{RPRE} must be derated by the $t_{JIT(per),act,max}$ of the input clock that exceeds $t_{JIT(per),allowed,max}$. Output deratings are relative to the input clock :

$$t_{RPRE}(min,derated) = 0.9 - \left[\frac{t_{JIT(per),act,max} - t_{JIT(per),allowed,max}}{t_{CK(avg)}} \right]$$

For example,

if the measured jitter into a LPDDR2-800 device has $t_{CK(avg)} = 2500ps$, $t_{JIT(per),act,min} = -172ps$, and $t_{JIT(per),act,max} = +193ps$, then $t_{RPRE,min,derated} = 0.9 - (t_{JIT(per),act,max} - t_{JIT(per),allowed,max})/t_{CK(avg)} = 0.9 - (193 - 100)/2500 = 0.8628 t_{CK(avg)}$.

tLZ(DQ), tHZ(DQ), tDQSCK, tLZ(DQS), tHZ(DQS)

These parameters are measured from a specific clock edge to a data signal transition (DM_n or DQ_m , where: $n = 0, 1, 2, \text{ or } 3$; and $m = DQ[31:0]$), and specified timings must be met with respect to that clock edge. Therefore, they are not affected by $t_{JIT(per)}$.

tQSH, tQSL

These parameters are affected by duty cycle jitter, represented by $t_{CH(abs)min}$ and $t_{CL(abs)min}$. These parameters determine the absolute data valid window at the device pin. The absolute minimum data valid window at the device pin = $\min [(t_{QSH}(abs)min \times t_{CK}(avg)min - t_{DQS}max - t_{QHS}max), (t_{QSL}(abs)min \times t_{CK}(avg)min - t_{DQS}max - t_{QHS}max)]$. This minimum data valid window must be met at the target frequency regardless of clock jitter.

tRPST

t_{RPST} is affected by duty cycle jitter, represented by $t_{CL(abs)}$. Therefore, $t_{RPST}(abs)min$ can be specified by $t_{CL}(abs)min$. $t_{RPST}(abs)min = t_{CL}(abs)min - 0.05 = t_{QSL}(abs)min$.

Clock Jitter Effects on WRITE Timing Parameters

tDS, tDH

These parameters are measured from a data signal (DM_n or DQ_m, where $n = 0, 1, 2, 3$; and $m = \text{DQ}[31:0]$) transition edge to its respective data strobe signal (DQS_n, DQS_{n#}: $n = 0, 1, 2, 3$) crossing. The specification values are not affected by the amount of tJIT(per) applied, because the setup and hold times are relative to the clock signal crossing that latches the command/address. Regardless of clock jitter values, these values must be met.

tDSS, tDSH

These parameters are measured from a data strobe signal crossing (DQS_x, DQS_{x#}) to its clock signal crossing (CK/CK#).

The specification values are not affected by the amount of tJIT(per) applied, because the setup and hold times are relative to the clock signal crossing that latches the command/address. Regardless of clock jitter values, these values must be met.

tDQSS

tDQSS is measured from the clock signal crossing (CK/CK#) to the first latching data strobe signal crossing (DQS_x, DQS_{x#}). *When the device is operated with input clock jitter, this parameter must be derated by the actual tJIT(per),act of the input clock in excess of tJIT(per),allowed.*

$$t_{DQSS}(\text{min,derated}) = 0.75 - \left(\frac{t_{JIT}(\text{per),act,min} - t_{JIT}(\text{per),allowed,min}}{t_{CK}(\text{avg})} \right)$$

$$t_{DQSS}(\text{max,derated}) = 1.25 - \left(\frac{t_{JIT}(\text{per),act,max} - t_{JIT}(\text{per),allowed,max}}{t_{CK}(\text{avg})} \right)$$

For example,

if the measured jitter into an LPDDR2-800 device has tCK(avg)=2500ps, tJIT(per) ,act, min=-172ps, and tJIT(per) ,act, max=+193ps, then : tDQSS,(min, derated)=0.75 - (tJIT(per) ,act, min - tJIT(per) ,allowed, min)/tCK(avg)=0.75 - (-172 + 100)/2500=0.7788 tCK(avg), and tDQSS,(max, derated)=1.25 - (tJIT(per) ,act, max - tJIT(per) ,allowed, max)/tCK(avg)=1.25 - (193 - 100)/2500=1.2128 tCK(avg).

Refresh Requirements

Table 75: Refresh Requirement Parameters (Per Density)

| Parameter | Symbol | 64Mb | 128Mb | 256Mb | 512Mb | 1Gb | 2Gb | 4Gb | 8Gb | Unit | |
|--|--------|---------|---------------------------------|-------|-------|------|--------|--------|--------|--------|----|
| Number of banks | | 4 | 4 | 4 | 4 | 8 | 8 | 8 | 8 | | |
| Refreshwindow:TCASE≤85° | tREFW | 32 | 32 | 32 | 32 | 32 | 32 | 32 | 32 | ms | |
| Refresh window 85°C<TCASE≤105°C | tREFW | 8 | 8 | 8 | 8 | 8 | 8 | 8 | 8 | ms | |
| Required number of REFRESH command(MIN) | R | 2048 | 2048 | 4096 | 4096 | 4096 | 8192 | 8192 | 8192 | | |
| Average time between REFRESH commands (for reference only) TCASE ≤ 85°C | REFab | tREFI | 15.6 | 15.6 | 7.8 | 7.8 | 7.8 | 3.9 | 3.9 | 3.9 | us |
| | REFpb | tREFIpb | (REFpb not supported below 1Gb) | | | | 0.9750 | 0.4875 | 0.4875 | 0.4875 | us |
| Refresh cycle time | tRFCab | 90 | 90 | 90 | 90 | 130 | 130 | 130 | 210 | ns | |
| Per-bank REFRESH cycle time | tRFCpb | na | | | | 60 | 60 | 60 | 90 | ns | |
| Burst REFRESH window = 4 × 8 × tRFCab | tREFBW | 2.88 | 2.88 | 2.88 | 2.88 | 4.16 | 4.16 | 4.16 | 6.72 | us | |

Table 77: AC Timing

Notes 1–2 apply to all parameters and conditions.

AC timing parameters must satisfy the tCK minimum conditions (in multiples of tCK) as well as the timing specifications when values for both are indicated.

| Parameter | Symbol | Min / Max | tCK Min | Data Rate | | | | | Unit | Notes |
|---|--------------------|-----------|---------|---|------|------|------|------|-----------|-------|
| | | | | 800 | 667 | 533 | 400 | 333 | | |
| Maximum frequency | | - | - | 400 | 333 | 266 | 200 | 166 | MHz | |
| Clock timing | | | | | | | | | | |
| Average clock period | tCK (avg) | MIN | - | 2.5 | 3 | 3.75 | 5 | 6 | ns | |
| | | MAX | - | - | - | - | - | - | | |
| Average HIGH pulse width | tCH (avg) | MIN | - | 0.45 | 0.45 | 0.45 | 0.45 | 0.45 | tCK (avg) | |
| | | MAX | - | 0.55 | 0.55 | 0.55 | 0.55 | 0.55 | | |
| Average LOW pulse width | tCL (avg) | MIN | - | 0.45 | 0.45 | 0.45 | 0.45 | 0.45 | tCK (avg) | |
| | | MAX | - | 0.55 | 0.55 | 0.55 | 0.55 | 0.55 | | |
| Absolute clock period | tCK (abs) | MIN | - | tCK(avg)min ± JIT(per)min | | | | | ps | |
| Absolute clock HIGH pulse width | tCH (abs) | MIN | - | 0.43 | 0.43 | 0.43 | 0.43 | 0.43 | tCK (avg) | |
| | | MAX | - | 0.57 | 0.57 | 0.57 | 0.57 | 0.57 | | |
| Absolute clock LOW pulse width | tCL (abs) | MIN | - | 0.43 | 0.43 | 0.43 | 0.43 | 0.43 | tCK (avg) | |
| | | MAX | - | 0.57 | 0.57 | 0.57 | 0.57 | 0.57 | | |
| Clock period jitter (with supported jitter) | tJIT(per), allowed | MIN | - | -100 | -110 | -120 | -140 | -150 | ps | |
| | | MAX | - | 100 | 110 | 120 | 140 | 150 | | |
| Maximum clock jitter between two consecutive clock cycles (with supported jitter) | tJIT(cc), allowed | MAX | - | 200 | 220 | 240 | 280 | 300 | ps | |
| Duty cycle jitter (with supported jitter) | JIT(duty), allowed | MIN | - | MIN ((tCH(abs),min - tCH(avg),min), (tCL(abs),min - tCL(avg),min)) × tCK(avg) | | | | | ps | |
| | | MAX | - | MAX ((tCH(abs),max - tCH(avg), max), (tCL(abs),max - tCL(avg), max)) × tCK(avg) | | | | | | |
| Cumulative errors across 2cycles | ERR(2per), allowed | MIN | - | -147 | -162 | -177 | -206 | -221 | ps | |
| | | MAX | - | 147 | 162 | 177 | 206 | 221 | | |
| Cumulative errors across 3cycles | ERR(3per), allowed | MIN | - | -175 | -192 | -210 | -245 | -262 | ps | |
| | | MAX | - | 175 | 192 | 210 | 245 | 262 | | |
| Cumulative errors across 4cycles | ERR(4per), allowed | MIN | - | -194 | -214 | -233 | -272 | -291 | ps | |
| | | MAX | - | 194 | 214 | 233 | 272 | 291 | | |
| Cumulative errors across 5cycles | ERR(5per), allowed | MIN | - | -209 | -230 | -251 | -293 | -314 | ps | |
| | | MAX | - | 209 | 230 | 251 | 293 | 314 | | |
| Cumulative errors across 6cycles | ERR(6per), allowed | MIN | - | -222 | -244 | -266 | -311 | -333 | ps | |
| | | MAX | - | 222 | 244 | 266 | 311 | 333 | | |
| Cumulative errors across 7cycles | ERR(7per), allowed | MIN | - | -232 | -256 | -279 | -325 | -348 | ps | |
| | | MAX | - | 232 | 256 | 279 | 325 | 348 | | |

Table 77: AC Timing (Continued)

Notes 1–2 apply to all parameters and conditions.

AC timing parameters must satisfy the tCK minimum conditions (in multiples of tCK) as well as the timing specifications when values for both are indicated.

| Parameter | Symbol | Min /Max | tCK Min | Data Rate | | | | | Unit | Notes |
|---|---------------------|----------|---------|---|------|------|------|------|-----------|-------|
| | | | | 800 | 667 | 533 | 400 | 333 | | |
| Cumulative errors across 8 cycles | tERR(8per) allowed | MIN | - | -241 | -266 | -290 | -338 | -362 | ps | |
| | | MAX | - | 241 | 266 | 290 | 338 | 362 | | |
| Cumulative errors across 9 cycles | tERR(9per) allowed | MIN | - | -249 | -274 | -299 | -349 | -374 | ps | |
| | | MAX | - | 249 | 274 | 299 | 349 | 374 | | |
| Cumulative errors across 10 cycles | tERR(10per) allowed | MIN | - | -257 | -282 | -308 | -359 | -385 | ps | |
| | | MAX | - | 257 | 282 | 308 | 359 | 385 | | |
| Cumulative errors across 11 cycles | tERR(11per) allowed | MIN | - | -263 | -289 | -316 | -368 | -395 | ps | |
| | | MAX | - | 263 | 289 | 316 | 368 | 395 | | |
| Cumulative errors across 12 cycles | tERR(12per) allowed | MIN | - | -269 | -296 | -323 | -377 | -403 | ps | |
| | | MAX | - | 269 | 296 | 323 | 377 | 403 | | |
| Cumulative errors across n = 13, 14, 15, ..., 49, 50 cycles | tERR(nper) allowed | MIN | - | tERR(nper), allowed, min = (1 + 0.68ln(n)) × tJIT(per), allowed, min | | | | | ps | |
| | | MAX | - | tERR(nper), allowed, max = (1 + 0.68ln(n)) × tJIT(per), allowed, max | | | | | | |
| ZQ Calibration Parameters | | | | | | | | | | |
| Initialization calibration time | tZQINIT | MIN | - | 1 | 1 | 1 | 1 | 1 | us | |
| Long calibration time | tZQCL | MIN | 6 | 360 | 360 | 360 | 360 | 360 | ns | |
| Short calibration time | tZQCS | MIN | 6 | 90 | 90 | 90 | 90 | 90 | ns | |
| Calibration RESET time | tZQRESET | MIN | 3 | 50 | 50 | 50 | 50 | 50 | ns | |
| READ Parameter | | | | | | | | | | |
| DQS output access Time from CK/CK# | tDQSCK | MIN | - | 2500 | 2500 | 2500 | 2500 | 2500 | ps | |
| | | MAX | - | 5500 | 5500 | 5500 | 5500 | 5500 | | |
| DQSCK delta short | tDQSCKDS | MAX | - | 450 | 540 | 670 | 900 | 1080 | ps | 4 |
| DQSCK delta medium | tDQSCKDM | MAX | - | 900 | 1050 | 1350 | 1800 | 1900 | ps | 5 |
| DQSCK delta long | tDQSCKDL | MAX | - | 1200 | 1400 | 1800 | 2400 | - | ps | 6 |
| DQS-DQ skew | tDQSQ | MAX | - | 240 | 280 | 340 | 400 | 500 | ps | |
| Data-hold skew factor | tQHS | MAX | - | 280 | 340 | 400 | 480 | 600 | ps | |
| DQS output HIGH pulse width | tQSH | MIN | - | tCH(abs) - 0.05 | | | | | tCK (avg) | |
| DQS output LOW pulse width | tQSL | MIN | - | tCL(abs) - 0.05 | | | | | tCK (avg) | |
| DATA half period | tQHP | MIN | - | MIN (tQSH, tQSL) | | | | | tCK (avg) | |
| DQ/DQS output hold time from DQS | tQH | MIN | - | tQHP - tQHS | | | | | ps | |

Table 78: AC Timing (Continued)

Notes 1–2 apply to all parameters and conditions.

AC timing parameters must satisfy the tCK minimum conditions (in multiples of tCK) as well as the timing specifications when values for both are indicated.

| Parameter | Symbol | Min / Max | tCK Min | Data Rate | | | | | Unit | Notes |
|--|----------|-----------|---------|----------------------------------|------|------|------|------|-----------|-------|
| | | | | 800 | 667 | 533 | 400 | 333 | | |
| READ preamble | tRPRE | MIN | - | 0.9 | 0.9 | 0.9 | 0.9 | 0.9 | tCK (avg) | |
| READ postamble | tRPST | MIN | - | tCL(abs) - 0.05 | | | | | tCK (avg) | |
| DQS Low-Z from clock | tLZ(DQS) | MIN | - | tDQSCK (MIN) - 300 | | | | | ps | |
| DQ Low-Z from clock | tLZ(DQ) | MIN | - | tDQSCK(MIN) - (1.4 × tQHS(MAX)) | | | | | ps | |
| DQS High-Z from clock | tHZ(DQS) | MAX | - | tDQSCK (MAX) - 100 | | | | | ps | |
| DQ High-Z from clock | tHZ(DQ) | MAX | - | tDQSCK(MAX) + (1.4 × tDQSQ(MAX)) | | | | | ps | |
| WRITE Parameter | | | | | | | | | | |
| DQ and DM input hold time(VREF=based) | tDH | MIN | - | 270 | 350 | 430 | 480 | 600 | ps | |
| DQ and DM input setup time(VREF=based) | tDS | MIN | - | 270 | 350 | 430 | 480 | 600 | ps | |
| DQ and DM input pulse width | tDIPW | MIN | - | 0.35 | 0.35 | 0.35 | 0.35 | 0.35 | tCK (avg) | |
| Write command to first DQS latching transition | tDQSS | MIN | - | 0.75 | 0.75 | 0.75 | 0.75 | 0.75 | tCK (avg) | |
| | | MAX | - | 1.25 | 1.25 | 1.25 | 1.25 | 1.25 | | |
| DQS input high-level width | tDQSH | MIN | - | 0.4 | 0.4 | 0.4 | 0.4 | 0.4 | tCK (avg) | |
| DQS input low-level width | tDQSL | MIN | - | 0.4 | 0.4 | 0.4 | 0.4 | 0.4 | tCK (avg) | |
| DQS falling edge to CK setup time | tDSS | MIN | - | 0.2 | 0.2 | 0.2 | 0.2 | 0.2 | tCK (avg) | |
| DQS falling edge hold time from CK | tDSH | MIN | - | 0.2 | 0.2 | 0.2 | 0.2 | 0.2 | tCK (avg) | |
| Write postamble | tWPST | MIN | - | 0.4 | 0.4 | 0.4 | 0.4 | 0.4 | tCK (avg) | |
| Write preamble | tWPRE | MIN | - | 0.35 | 0.35 | 0.35 | 0.35 | 0.35 | tCK (avg) | |
| CKE Input Parameters | | | | | | | | | | |
| CKE minimum pulse width (HIGH and LOW pulse width) | tCKE | MIN | 3 | 3 | 3 | 3 | 3 | 3 | tCK (avg) | |
| CKE input setup time | tISCKE | MIN | - | 0.25 | 0.25 | 0.25 | 0.25 | 0.25 | tCK (avg) | 9 |
| CKE input hold time | tIHCKE | MIN | - | 0.25 | 0.25 | 0.25 | 0.25 | 0.25 | tCK (avg) | 10 |

Table 79: AC Timing (Continued)

Notes 1–2 apply to all parameters and conditions.

AC timing parameters must satisfy the tCK minimum conditions (in multiples of tCK) as well as the timing specifications when values for both are indicated.

| Parameter | Symbol | Min / Max | tCK Min | Data Rate | | | | | Unit | Notes |
|---|---------|-----------|---------|---|------|------|------|------|-----------|-------|
| | | | | 800 | 667 | 533 | 400 | 333 | | |
| Command Address Input Parameter | | | | | | | | | | |
| Address and control input setup time | tIS | MIN | - | 290 | 370 | 460 | 600 | 740 | ps | 11 |
| Address and control input hold time | tIH | MIN | - | 290 | 370 | 460 | 600 | 740 | ps | 11 |
| Address and control input pulse width | tIPW | MIN | - | 0.40 | 0.40 | 0.40 | 0.40 | 0.40 | tCK (avg) | |
| Boot Parameters(max 55MHz) | | | | | | | | | | |
| Clock cycle time | tCKb | MAX | - | - | - | - | - | - | ns | |
| | | MIN | | 18 | 18 | 18 | 18 | 18 | | |
| CKE input setup time | tISCKEb | MIN | - | 2.5 | 2.5 | 2.5 | 2.5 | 2.5 | ns | |
| CKE input hold time | tIHCKEb | MIN | - | 2.5 | 2.5 | 2.5 | 2.5 | 2.5 | ns | |
| Address and control input setup time | tISb | MIN | - | 1150 | 1150 | 1150 | 1150 | 1150 | ps | |
| Address and control input hold time | tIHb | MIN | - | 1150 | 1150 | 1150 | 1150 | 1150 | ps | |
| DQS output data Access time from CK/CK# | tDQSCKb | MIN | - | 2.0 | 2.0 | 2.0 | 2.0 | 2.0 | ns | |
| | | MAX | - | 10.0 | 10.0 | 10.0 | 10.0 | 10.0 | | |
| Data strobe edge to output data edge | tDQSQb | MIN | - | 1.2 | 1.2 | 1.2 | 1.2 | 1.2 | ns | |
| Data hold skew factor | tQHSb | MIN | - | 1.2 | 1.2 | 1.2 | 1.2 | 1.2 | ns | |
| Mode Register Parameter | | | | | | | | | | |
| MODE REGISTER WRITE command period | tMRW | MIN | 3 | 3 | 3 | 3 | 3 | 3 | tCK (avg) | |
| MODE REGISTER READ command period | tMRR | MIN | 2 | 2 | 2 | 2 | 2 | 2 | tCK (avg) | |
| Core Parameter | | | | | | | | | | |
| READ latency | RL | MIN | 3 | 6 | 5 | 4 | 3 | 3 | tCK (avg) | |
| WRITE latency | WL | MIN | 1 | 3 | 2 | 2 | 1 | 1 | tCK (avg) | |
| ACTIVATE-to-ACTIVATE command period | tRC | MIN | - | tRAS + tRPab (with all-bank precharge), tRAS + tRPpb (with per-bank precharge) | | | | | ns | 17 |
| CKE minimum pulse width during SELF REFRESH (low pulse width during SELF REFRESH) | tCKESR | MIN | 3 | 15 | 15 | 15 | 15 | 15 | ns | |
| SELF REFRESH exit to next valid command delay | tXSR | MIN | 2 | tRFCab + 10 | | | | | ns | |

Table 80: AC Timing (Continued)

Notes 1–2 apply to all parameters and conditions.

AC timing parameters must satisfy the tCK minimum conditions (in multiples of tCK) as well as the timing specifications when values for both are indicated.

| Parameter | Symbol | Min / Max | tCK Min | Data Rate | | | | | Unit | Notes |
|--|------------------|-----------|---------|-----------|------|------|------|------|-----------|-------|
| | | | | 800 | 667 | 533 | 400 | 333 | | |
| Exit power-down to next valid | tXP | MIN | 2 | 7.5 | 7.5 | 7.5 | 7.5 | 7.5 | ns | |
| LPDDR2-S4 CAS-to-CAS delay | tCCD | MIN | - | 2 | 2 | 2 | 2 | 2 | tCK (avg) | |
| Internal READ to PRECHARGE | tRTP | MIN | 2 | 7.5 | 7.5 | 7.5 | 7.5 | 7.5 | ns | |
| RAS-to-CAS delay | tRCD | Fast | 3 | 15 | 15 | 15 | 15 | 15 | ns | |
| | | Typ | 3 | 18 | 18 | 18 | 18 | 18 | | |
| Row precharge time (single bank) | tRPpb | Fast | 3 | 15 | 15 | 15 | 15 | 15 | ns | |
| | | Typ | 3 | 18 | 18 | 18 | 18 | 18 | | |
| Row precharge time (all banks) | tRPpab 8-bank | Fast | 3 | 18 | 18 | 18 | 18 | 18 | ns | |
| | | Typ | 3 | 21 | 21 | 21 | 21 | 21 | | |
| Row active time | tRAS | MIN | 3 | 42 | 42 | 42 | 42 | 42 | ns | |
| | | MAX | - | 70 | 70 | 70 | 70 | 70 | us | |
| WRITE recovery time | tWR | MIN | 3 | 15 | 15 | 15 | 15 | 15 | ns | |
| Internal WT-to-RD command delay | tWTR | MIN | 2 | 7.5 | 7.5 | 7.5 | 10 | 10 | ns | |
| Active bank <i>a</i> to active bank <i>b</i> | tRRD | MIN | 2 | 10 | 10 | 10 | 10 | 10 | ns | |
| Four-bank activate window | tFAW | MIN | 8 | 50 | 50 | 50 | 50 | 60 | ns | |
| Minimum deep power-down time | tDPD | MIN | - | 500 | 500 | 500 | 500 | 500 | us | |
| Temperature Derating | | | | | | | | | | |
| tDQSK derating | tDQSK (derating) | MAX | - | 6000 | 6000 | 6000 | 6000 | 6000 | ps | |

Table 81: AC Timing (Continued)

Notes 1–2 apply to all parameters and conditions.

AC timing parameters must satisfy the tCK minimum conditions (in multiples of tCK) as well as the timing specifications when values for both are indicated.

| Parameter | Symbol | Min / Max | tCK Min | Data Rate | | | | | Unit | Notes |
|--|-------------------|-----------|---------|--------------|-----|-----|-----|-----|------|-------|
| | | | | 800 | 667 | 533 | 400 | 333 | | |
| Core timing Temperature derating | tRCD (derated) | MIN | - | tRCD + 1.875 | | | | | ns | |
| | tRC (derated) | MIN | - | tRC + 1.875 | | | | | ns | |
| | tRAS (derated) | MIN | - | tRAS + 1.875 | | | | | ns | |
| | tRP (derated) | MIN | - | tRP + 1.875 | | | | | ns | |
| | tRRD (derated) | MIN | - | tRRD + 1.875 | | | | | ns | |

Notes : 1. Frequency values are for reference only. Clock cycle time (tCK) is used to determine device capabilities.

2. All AC timings assume an input slew rate of 1 V/ns.

3. READ, WRITE, and input setup and hold values are referenced to V_{REF}.

4. tDQSCKDS is the absolute value of the difference between any two tDQSCK measurements (in a byte lane) within a contiguous sequence of bursts in a 160ns rolling window. tDQSCKDS is not tested and is guaranteed by design.

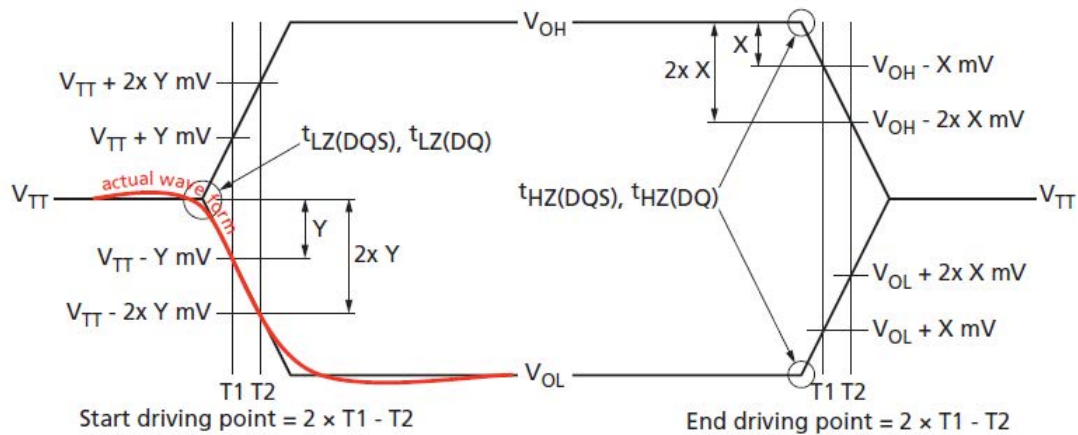
Temperature drift in the system is <10°C/s. Values do not include clock jitter.

5. tDQSCKDM is the absolute value of the difference between any two tDQSCK measurements (in a byte lane) within a 1.6µs rolling window. tDQSCKDM is not tested and is guaranteed by design. Temperature drift in the system is <10°C/s. Values do not include clock jitter.

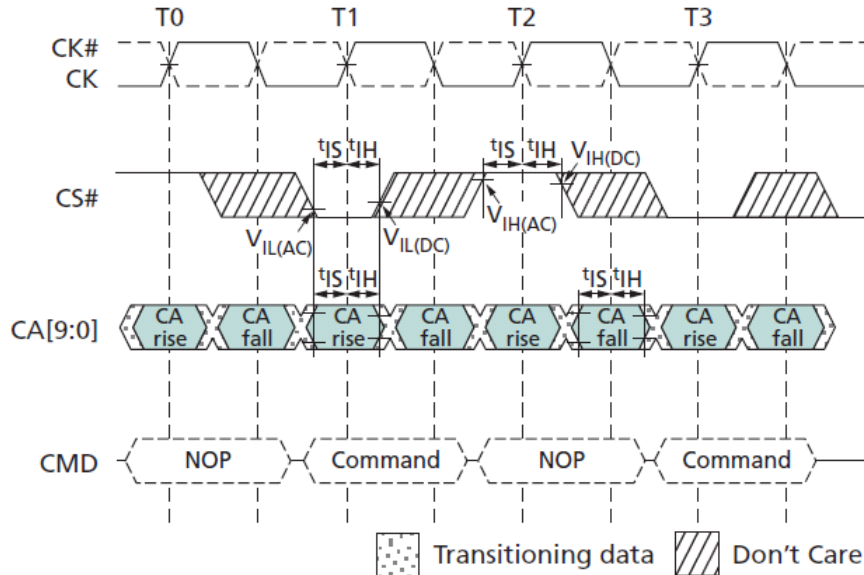
6. tDQSCKDL is the absolute value of the difference between any two tDQSCK measurements (in a byte lane) within a 32ms rolling window. tDQSCKDL is not tested and is guaranteed by design. Temperature drift in the system is <10°C/s. Values do not include clock jitter. For LOW-to-HIGH and HIGH-to-LOW transitions, the timing reference is at the point when the signal crosses the transition threshold (V_T). tHZ and tLZ transitions occur in the same access time (with respect to clock) as valid data transitions.

These parameters are not referenced to a specific voltage level but to the time when the device output is no longer driving (for tRPST, tHZ(DQS) and tHZ(DQ)), or begins driving (for tRPRE, tLZ(DQS), tLZ(DQ)). The figure below shows a method to calculate the point when the device is no longer driving tHZ(DQS) and tHZ(DQ) or begins driving tLZ(DQS) and tLZ(DQ) by measuring the signal at two different voltages. The actual voltage measurement points are not critical as long as the calculation is consistent. The parameters tLZ(DQS), tLZ(DQ), tHZ(DQS), and tHZ(DQ) are defined as single-ended.

The timing parameters tRPRE and tRPST are determined from the differential signal DQS/DQS#.

Output Transition Timing


7. Measured from the point when DQS/DQS# begins driving the signal, to the point when DQS/DQS# begins driving the first rising strobe edge.
8. Measured from the last falling strobe edge of DQS/DQS# to the point when DQS/DQS# finishes driving the signal.
9. CKE input setup time is measured from CKE reaching a HIGH/LOW voltage level to CK/CK# crossing.
10. CKE input hold time is measured from CK/CK# crossing to CKE reaching a HIGH/LOW voltage level.
11. Input setup/hold time for signal (CA[9:0], CS#).
12. To ensure device operation before the device is configured, a number of AC boot timing parameters are defined in this table. The letter b is appended to the boot parameter symbols (for example, t_{CK} during boot is t_{CKb}).
13. Mobile LPDDR2 devices set some mode register default values upon receiving a RESET (MRW) command, as specified in Mode Register Definition.
14. The output skew parameters are measured with default output impedance settings using the reference load.
15. The minimum t_{CK} column applies only when t_{CK} is greater than 6ns.
16. Timing derating applies for operation at 85°C to 105°C when the requirement to derate is indicated by mode register 4 op-code (see the MR4 Device Temperature (MA[7:0] =04h) table).
17. DRAM devices should be evenly addressed when being accessed. Disproportionate accesses to a particular row address may result in reduction of the product lifetime.

Figure 70: Command Input Setup and Hold Timing


Notes :1. The setup and hold timing shown applies to all commands.

2. Setup and hold conditions also apply to the CKE pin. For timing diagrams related to the CKE pin, see Power-Down.

CA and CS# Setup, Hold, and Derating

For all input signals (CA and CS#), the total required setup time (t_{IS}) and hold time (t_{IH}) is calculated by adding the data sheet t_{IS} (base) and t_{IH} (base) values to the Δt_{IS} and Δt_{IH} derating values, respectively. Example: t_{IS} (total setup time) = t_{IS} (base) + Δt_{IS} . (See the series of tables following this section.)

The typical setup slew rate (t_{IS}) for a rising signal is defined as the slew rate between the last crossing of $V_{REF(DC)}$ and the first crossing of $V_{IH(AC)MIN}$. The typical setup slew rate for a falling signal is defined as the slew rate between the last crossing of $V_{REF(DC)}$ and the first crossing of $V_{IL(AC)MAX}$. If the actual signal is consistently earlier than the typical slew rate line between the shaded $V_{REF(DC)}$ -to-(AC) region, use the typical slew rate for the derating value (see Figure 71). If the actual signal is later than the typical slew rate line anywhere between the shaded $V_{REF(DC)}$ -to-AC region, the slew rate of a tangent line to the actual signal from the AC level to the DC level is used for the derating value (see Figure 73).

The hold (t_{IH}) typical slew rate for a rising signal is defined as the slew rate between the last crossing of $V_{IL(DC)MAX}$ and the first crossing of $V_{REF(DC)}$. The hold (t_{IH}) typical slew rate for a falling signal is defined as the slew rate between the last crossing of $V_{IH(DC)MIN}$ and the first crossing of $V_{REF(DC)}$.

If the actual signal is consistently later than the typical slew rate line between the shaded DC-to- $V_{REF(DC)}$ region, use the typical slew rate for the derating value (see Figure 72). If the actual signal is earlier than the typical slew rate line anywhere between the shaded DC-to- $V_{REF(DC)}$ region, the slew rate of a tangent line to the actual signal from the DC level to $V_{REF(DC)}$ level is used for the derating value (see Figure 74).

For a valid transition, the input signal must remain above or below $V_{IH/VIL(AC)}$ for a specified time, t_{VAC} (see Table 86).

For slow slew rates the total setup time could be a negative value (that is, a valid input signal will not have reached $V_{IH/VIL(AC)}$ at the time of the rising clock transition). A valid input signal is still required to complete the transition and reach $V_{IH/VIL(AC)}$. For slew rates between the values listed in Table 84, the derating values are obtained using linear interpolation.

Slew rate values are not typically subject to production testing. They are verified by design and characterization.

Table 82: CA and CS# Setup and Hold Base Values (>400 MHz, 1 V/ns Slew Rate)

| Parameter | Data Rate | | | | Reference |
|-----------|-----------|-----|-----|-----|--|
| | 800 | 667 | 533 | 466 | |
| tIS(base) | 70 | 150 | 240 | 300 | $V_{IH/VIL(AC)} = V_{REF(DC)} \pm 220mV$ |
| tIH(base) | 160 | 240 | 330 | 390 | $V_{IH/VIL(DC)} = V_{REF(DC)} \pm 130mV$ |

Note : 1. AC/DC referenced for 1 V/ns CA and CS# slew rate, and 2 V/ns differential CK/CK# slew rate

Table 83: CA and CS# Setup and Hold Base Values (<400 MHz, 1 V/ns Slew Rate)

| Parameter | Data Rate | | | | Reference |
|-----------|-----------|-----|-----|-----|--|
| | 400 | 333 | 255 | 200 | |
| tIS(base) | 300 | 440 | 600 | 850 | $V_{IH/VIL(AC)} = V_{REF(DC)} \pm 300mV$ |
| tIH(base) | 400 | 540 | 700 | 950 | $V_{IH/VIL(DC)} = V_{REF(DC)} \pm 200mV$ |

Note : 1. AC/DC referenced for 1 V/ns CA and CS# slew rate, and 2 V/ns differential CK/CK# slew rate

Table 84: Derating Values for AC/DC-Based tIS/tIH (AC220)

ΔtIS , ΔtIH derating in ps

| | | CK, CK# Differential Slew Rate | | | | | | | | | | | | | | | |
|------------------------------------|-----|--------------------------------|--------------|--------------|--------------|--------------|--------------|--------------|--------------|--------------|--------------|--------------|--------------|--------------|--------------|--------------|--------------|
| | | 4.0V/ns | | 3.0V/ns | | 2.0V/ns | | 1.8V/ns | | 1.6V/ns | | 1.4V/ns | | 1.2V/ns | | 1.0V/ns | |
| | | ΔtIS | ΔtIH | ΔtIS | ΔtIH | ΔtIS | ΔtIH | ΔtIS | ΔtIH | ΔtIS | ΔtIH | ΔtIS | ΔtIH | ΔtIS | ΔtIH | ΔtIS | ΔtIH |
| CA, CS# slew rate V/ns | 2.0 | 110 | 65 | 110 | 65 | 110 | 65 | | | | | | | | | | |
| | 1.5 | 74 | 43 | 73 | 43 | 73 | 43 | 89 | 59 | | | | | | | | |
| | 1.0 | 0 | 0 | 0 | 0 | 0 | 0 | 16 | 16 | 32 | 32 | | | | | | |
| | 0.9 | | | -3 | -5 | -3 | -5 | 13 | 11 | 29 | 27 | 45 | 43 | | | | |
| | 0.8 | | | | | -8 | -13 | 8 | 3 | 24 | 19 | 40 | 35 | 56 | 55 | | |
| | 0.7 | | | | | | | 2 | -6 | 18 | 10 | 34 | 26 | 50 | 46 | 66 | 78 |
| | 0.6 | | | | | | | | | 10 | -3 | 26 | 13 | 42 | 33 | 58 | 65 |
| | 0.5 | | | | | | | | | | | 4 | -4 | 20 | 16 | 36 | 48 |
| | 0.4 | | | | | | | | | | | | | -7 | 2 | 17 | 34 |

Note : 1. Shaded cells are not supported.

Table 85: Derating Values for AC/DC-Based tIS/tIH (AC300)
 ΔtIS , ΔtIH derating in ps

| | | CK, CK# Differential Slew Rate | | | | | | | | | | | | | | | |
|------------------------------------|-----|--------------------------------|--------------|--------------|--------------|--------------|--------------|--------------|--------------|--------------|--------------|--------------|--------------|--------------|--------------|--------------|--------------|
| | | 4.0V/ns | | 3.0V/ns | | 2.0V/ns | | 1.8V/ns | | 1.6V/ns | | 1.4V/ns | | 1.2V/ns | | 1.0V/ns | |
| | | ΔtIS | ΔtIH | ΔtIS | ΔtIH | ΔtIS | ΔtIH | ΔtIS | ΔtIH | ΔtIS | ΔtIH | ΔtIS | ΔtIH | ΔtIS | ΔtIH | ΔtIS | ΔtIH |
| CA, CS# slew rate V/ns | 2.0 | 150 | 100 | 150 | 100 | 150 | 100 | | | | | | | | | | |
| | 1.5 | 100 | 67 | 100 | 67 | 100 | 67 | 116 | 83 | | | | | | | | |
| | 1.0 | 0 | 0 | 0 | 0 | 0 | 0 | 16 | 16 | 32 | 32 | | | | | | |
| | 0.9 | | | -4 | -8 | -4 | -8 | 12 | 8 | 28 | 24 | 44 | 40 | | | | |
| | 0.8 | | | | | -12 | -20 | 4 | -4 | 20 | 12 | 36 | 28 | 52 | 48 | | |
| | 0.7 | | | | | | | -3 | -18 | 13 | -2 | 29 | 14 | 45 | 34 | 61 | 66 |
| | 0.6 | | | | | | | | | 2 | -21 | 18 | -5 | 34 | 15 | 50 | 47 |
| | 0.5 | | | | | | | | | | | -12 | -32 | 4 | -12 | 20 | 20 |
| | 0.4 | | | | | | | | | | | | | -35 | -40 | -11 | -8 |

Note : 1. Shaded cells are not supported.

Table 86: Required Time for Valid Transition – $tVAC > V_{IH(AC)}$ and $< V_{IL(AC)}$

| Slew Rate (V/ns) | tVAC at 300mV(ps) | | tVAC at 220mV(ps) | |
|------------------|-------------------|-----|-------------------|-----|
| | Min | Max | Min | Max |
| >2.0 | 75 | - | 175 | - |
| 2.0 | 57 | - | 170 | - |
| 1.5 | 50 | - | 167 | - |
| 1.0 | 38 | - | 163 | - |
| 0.9 | 34 | - | 162 | - |
| 0.8 | 29 | - | 161 | - |
| 0.7 | 22 | - | 159 | - |
| 0.6 | 13 | - | 155 | - |
| 0.5 | 0 | - | 150 | - |
| <0.5 | 0 | - | 150 | - |

Figure 71: Typical Slew Rate and $t_{VAC} - t_{IS}$ for CA and CS# Relative to Clock

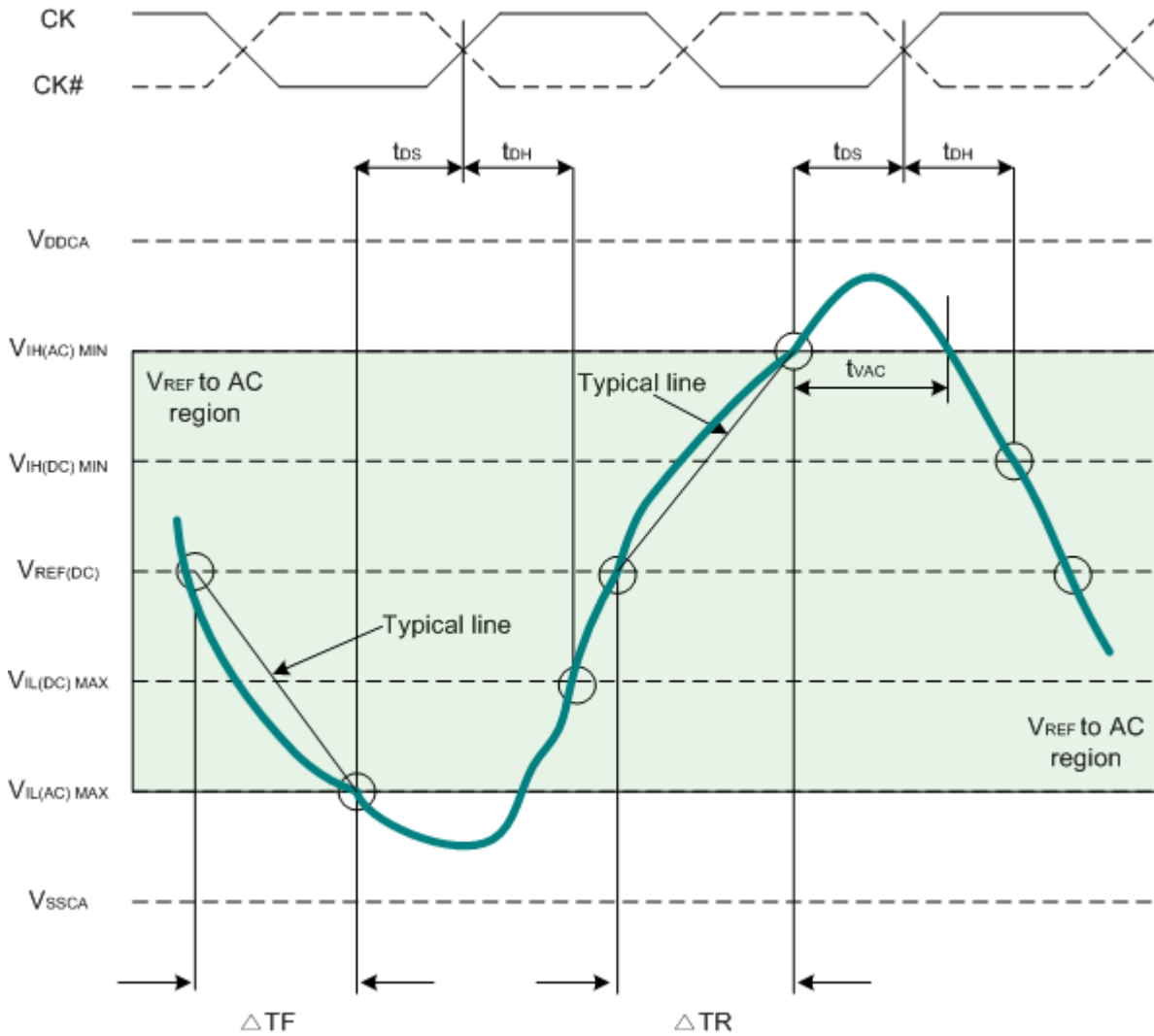


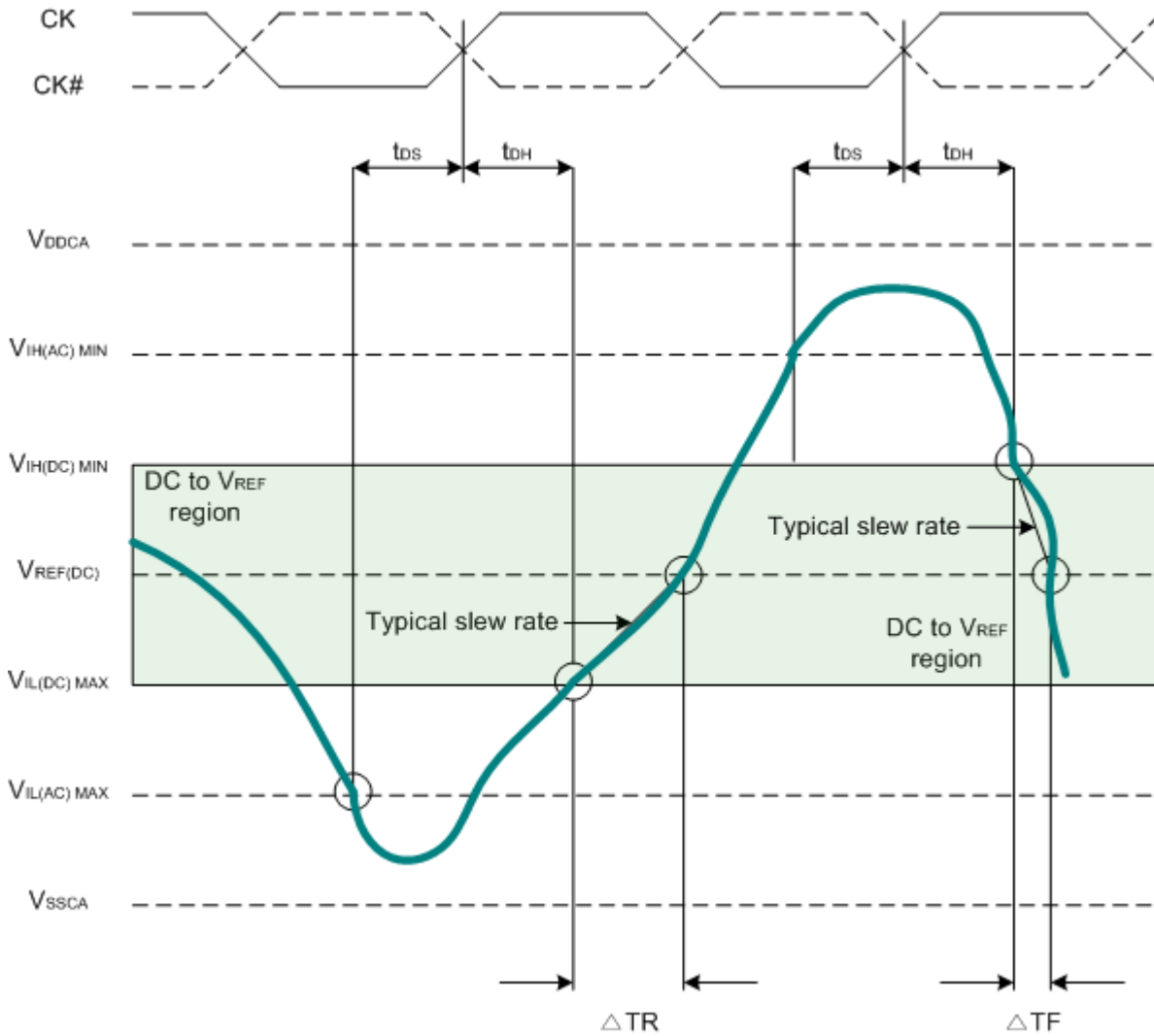
Figure 72: Typical Slew Rate – t_{IH} for CA and CS# Relative to Clock


Figure 73: Tangent Line – tIS for CA and CS# Relative to Clock

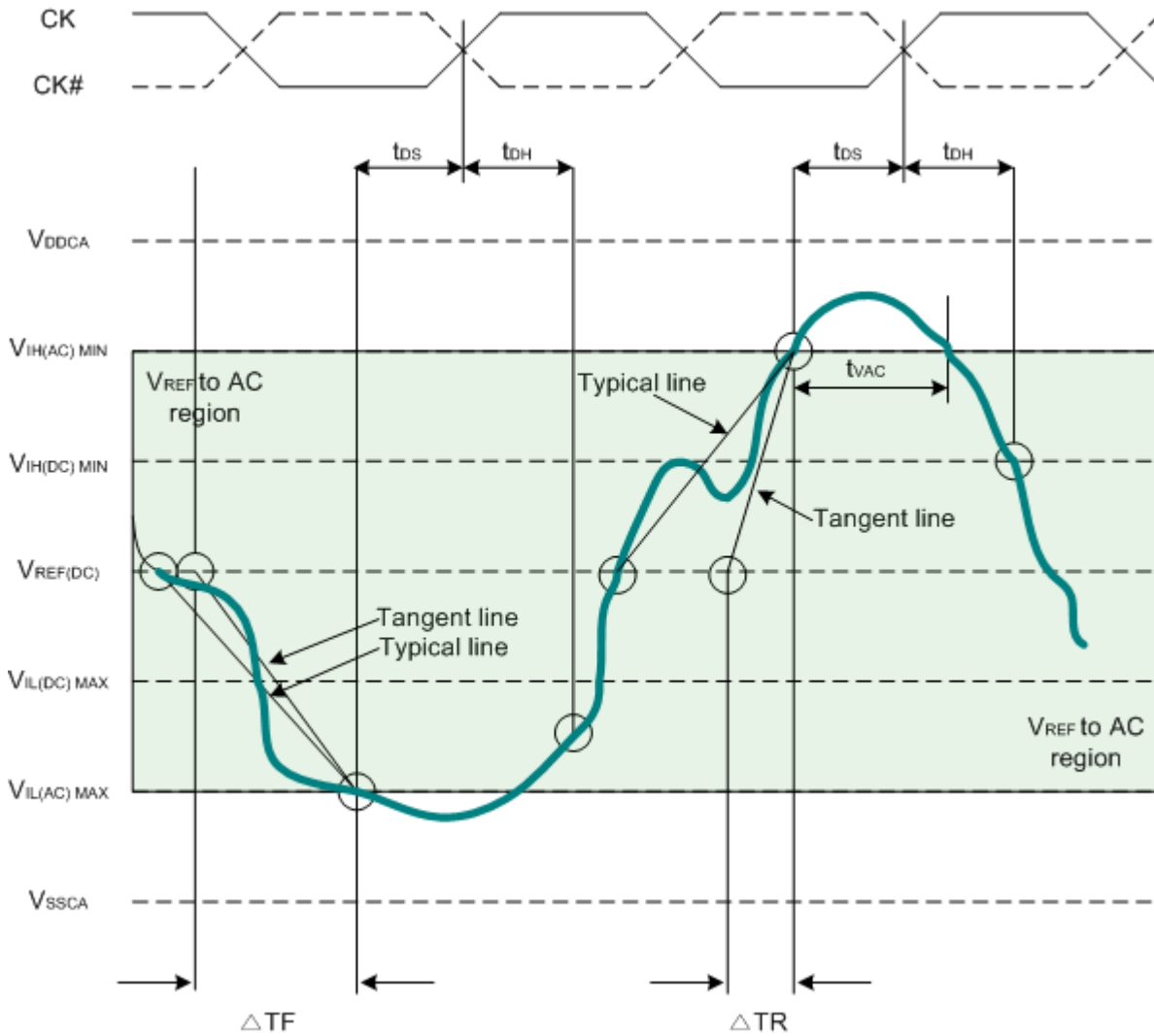
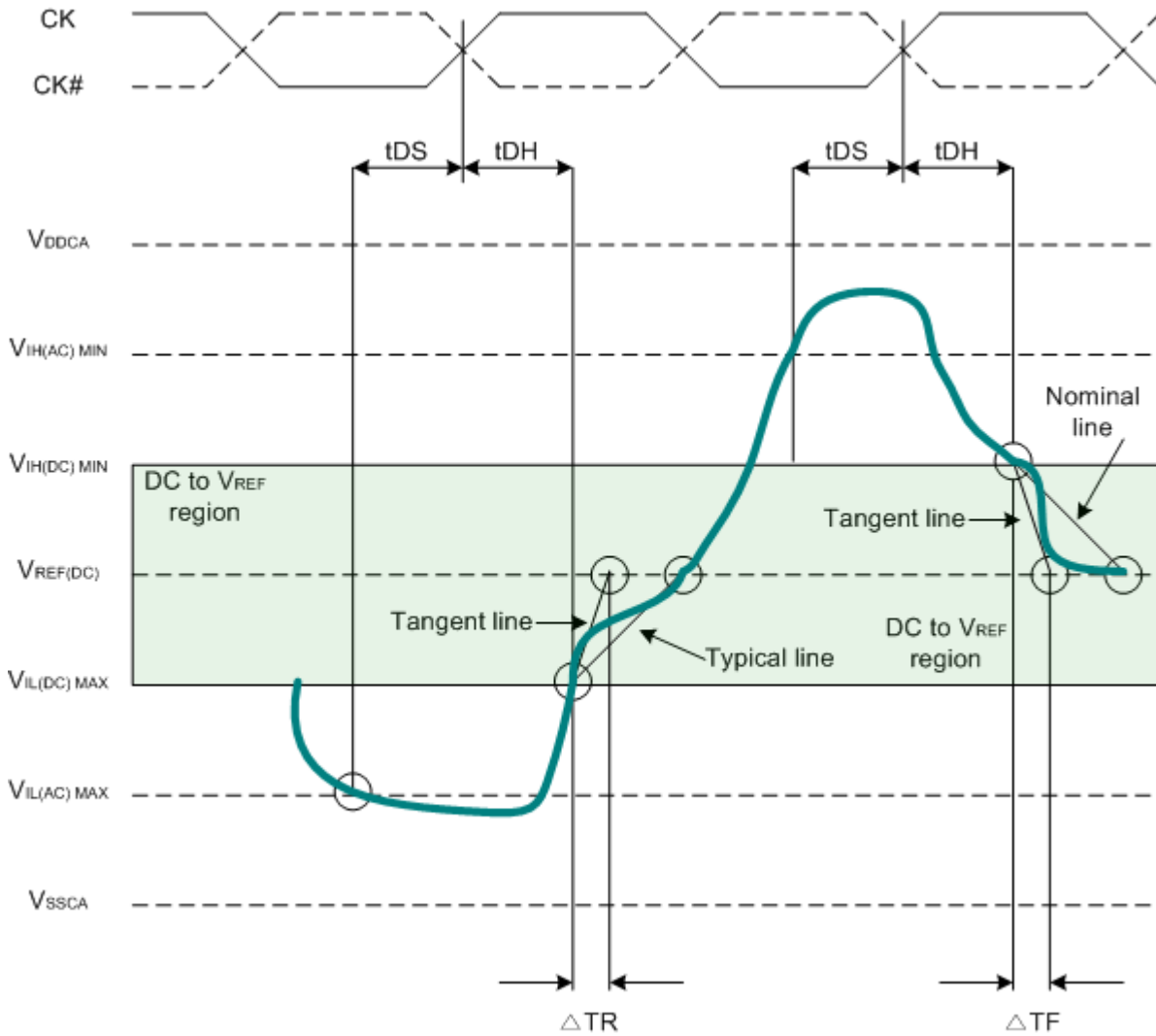


Figure 74: Tangent Line – tIH for CA and CS# Relative to Clock



Data Setup, Hold, and Slew Rate Derating

For all input signals (DQ, DM) calculate the total required setup time (t_{DS}) and hold time (t_{DH}) by adding the data sheet $t_{DS}(\text{base})$ and $t_{DH}(\text{base})$ values (see Table 87) to the Δt_{DS} and Δt_{DH} derating values, respectively (see Table 89 and Table 90).

Example: $t_{DS} = t_{DS}(\text{base}) + \Delta t_{DS}$. The typical t_{DS} slew rate for a rising signal is defined as the slew rate between the last crossing of $V_{REF(DC)}$ and the first crossing of $V_{IH(AC)MIN}$. The typical t_{DS} slew rate for a falling signal is defined as the slew rate between the last crossing of $V_{REF(DC)}$ and the first crossing of $V_{IL(AC)MAX}$ (see Figure 75).

If the actual signal is consistently earlier than the typical slew rate line in Figure 71) the area shaded gray between the $V_{REF(DC)}$ region and the AC region, use the typical slew rate for the derating value. If the actual signal is later than the typical slew rate line anywhere between the shaded $V_{REF(DC)}$ region and the AC region, the slew rate of a tangent line to the actual signal from the AC level to the DC level is used for the derating value (see Figure 73).

The typical t_{DH} slew rate for a rising signal is defined as the slew rate between the last crossing of $V_{IL(DC)MAX}$ and the first crossing of $V_{REF(DC)}$. The typical t_{DH} slew rate for a falling signal is defined as the slew rate between the last crossing of $V_{IH(DC)MIN}$ and the first crossing of $V_{REF(DC)}$ (see Figure 76).

If the actual signal is consistently later than the typical slew rate line between the shaded DC-level-to- $V_{REF(DC)}$ region, use the typical slew rate for the derating value. If the actual signal is earlier than the typical slew rate line anywhere between shaded DC-to- $-V_{REF(DC)}$ region, the slew rate of a tangent line to the actual signal from the DC level to the $V_{REF(DC)}$ level is used for the derating value (see Figure 78).

For a valid transition, the input signal must remain above or below $V_{IH/VIL(AC)}$ for the specified time, t_{VAC} (see Table 91).

The total setup time for slow slew rates could be negative (that is, a valid input signal may not have reached $V_{IH/VIL(AC)}$ at the time of the rising clock transition). A valid input signal is still required to complete the transition and reach $V_{IH/VIL(AC)}$.

For slew rates between the values listed in Table 87 and Table 88, the derating values can be obtained using linear interpolation. Slew rate values are not typically subject to production testing. They are verified by design and characterization.

Table 87: Data Setup and Hold Base Values (>400 MHz, 1 V/ns Slew Rate)

| Parameter | Data Rate | | | | Reference |
|-----------------------|-----------|-----|-----|-----|---|
| | 800 | 667 | 533 | 466 | |
| $t_{DS}(\text{base})$ | 50 | 130 | 210 | 230 | $V_{IH/VIL(AC)} = V_{REF(DC)} \pm 220\text{mV}$ |
| $t_{DH}(\text{base})$ | 140 | 220 | 300 | 320 | $V_{IH/VIL(DC)} = V_{REF(DC)} \pm 130\text{mV}$ |

Table 88: Data Setup and Hold Base Values (<400 MHz, 1 V/ns Slew Rate)

| Parameter | Data Rate | | | | Reference |
|-----------------------|-----------|-----|-----|-----|---|
| | 400 | 333 | 255 | 200 | |
| $t_{DS}(\text{base})$ | 180 | 300 | 450 | 700 | $V_{IH/VIL(AC)} = V_{REF(DC)} \pm 300\text{mV}$ |
| $t_{DH}(\text{base})$ | 280 | 400 | 550 | 800 | $V_{IH/VIL(DC)} = V_{REF(DC)} \pm 200\text{mV}$ |

Note : 1. AC/DC referenced for 1 V/ns DQ, DM slew rate, and 2 V/ns differential DQS/DQS# slew rate

Table 89: Derating Values for AC/DC-Based tDS/tDH (AC220)
 ΔtDS , ΔtDH derating in ps

| | | DQS, DQS# Differential Slew Rate | | | | | | | | | | | | | | | |
|-----------------------------------|-----|----------------------------------|--------------|--------------|--------------|--------------|--------------|--------------|--------------|--------------|--------------|--------------|--------------|--------------|--------------|--------------|--------------|
| | | 4.0V/ns | | 3.0V/ns | | 2.0V/ns | | 1.8V/ns | | 1.6V/ns | | 1.4V/ns | | 1.2V/ns | | 1.0V/ns | |
| | | ΔtDS | ΔtDH | ΔtDS | ΔtDH | ΔtDS | ΔtDH | ΔtDS | ΔtDH | ΔtDS | ΔtDH | ΔtDS | ΔtDH | ΔtDS | ΔtDH | ΔtDS | ΔtDH |
| DQ, DM slew rate V/ns | 2.0 | 110 | 65 | 110 | 65 | 110 | 65 | | | | | | | | | | |
| | 1.5 | 74 | 43 | 73 | 43 | 73 | 43 | 89 | 59 | | | | | | | | |
| | 1.0 | 0 | 0 | 0 | 0 | 0 | 0 | 16 | 16 | 32 | 32 | | | | | | |
| | 0.9 | | | -3 | -5 | -3 | -5 | 13 | 11 | 29 | 27 | 45 | 43 | | | | |
| | 0.8 | | | | | -8 | -13 | 8 | 3 | 24 | 19 | 40 | 35 | 56 | 55 | | |
| | 0.7 | | | | | | | 2 | -6 | 18 | 10 | 34 | 26 | 50 | 46 | 66 | 78 |
| | 0.6 | | | | | | | | | 10 | -3 | 26 | 13 | 42 | 33 | 58 | 65 |
| | 0.5 | | | | | | | | | | | 4 | -4 | 20 | 16 | 36 | 48 |
| | 0.4 | | | | | | | | | | | | | -7 | 2 | 17 | 34 |

Note : 1. Shaded cells are not supported.

Table 90: Derating Values for AC/DC-Based tDS/tDH (AC300)
 ΔtDS , ΔtDH derating in ps

| | | DQS, DQS# Differential Slew Rate | | | | | | | | | | | | | | | |
|-----------------------------------|-----|----------------------------------|--------------|--------------|--------------|--------------|--------------|--------------|--------------|--------------|--------------|--------------|--------------|--------------|--------------|--------------|--------------|
| | | 4.0V/ns | | 3.0V/ns | | 2.0V/ns | | 1.8V/ns | | 1.6V/ns | | 1.4V/ns | | 1.2V/ns | | 1.0V/ns | |
| | | ΔtDS | ΔtDH | ΔtDS | ΔtDH | ΔtDS | ΔtDH | ΔtDS | ΔtDH | ΔtDS | ΔtDH | ΔtDS | ΔtDH | ΔtDS | ΔtDH | ΔtDS | ΔtDH |
| DQ, DM slew rate V/ns | 2.0 | 150 | 100 | 150 | 100 | 150 | 100 | | | | | | | | | | |
| | 1.5 | 100 | 67 | 100 | 67 | 100 | 67 | 116 | 83 | | | | | | | | |
| | 1.0 | 0 | 0 | 0 | 0 | 0 | 0 | 16 | 16 | 32 | 32 | | | | | | |
| | 0.9 | | | -4 | -8 | -4 | -8 | 12 | 8 | 28 | 24 | 44 | 40 | | | | |
| | 0.8 | | | | | -12 | -20 | 4 | -4 | 20 | 12 | 36 | 28 | 52 | 48 | | |
| | 0.7 | | | | | | | -3 | -18 | 13 | -2 | 29 | 14 | 45 | 34 | 61 | 66 |
| | 0.6 | | | | | | | | | 2 | -21 | 18 | -5 | 34 | 15 | 50 | 47 |
| | 0.5 | | | | | | | | | | | -12 | -32 | 4 | -12 | 20 | 20 |
| | 0.4 | | | | | | | | | | | 4 | -35 | -40 | -11 | -8 | |

Note : 1. Shaded cells are not supported.

Table 91: Required Time for Valid Transition – $t_{VAC} > V_{IH(AC)}$ or $< V_{IL(AC)}$

| Slew Rate (V/ns) | tVAC at 300mV(ps) | | tVAC at 220mV(ps) | |
|------------------|-------------------|-----|-------------------|-----|
| | Min | Max | Min | Max |
| >2.0 | 75 | - | 175 | - |
| 2.0 | 57 | - | 170 | - |
| 1.5 | 50 | - | 167 | - |
| 1.0 | 38 | - | 163 | - |
| 0.9 | 34 | - | 162 | - |
| 0.8 | 29 | - | 161 | - |
| 0.7 | 22 | - | 159 | - |
| 0.6 | 13 | - | 155 | - |
| 0.5 | 0 | - | 150 | - |
| <0.5 | 0 | - | 150 | - |

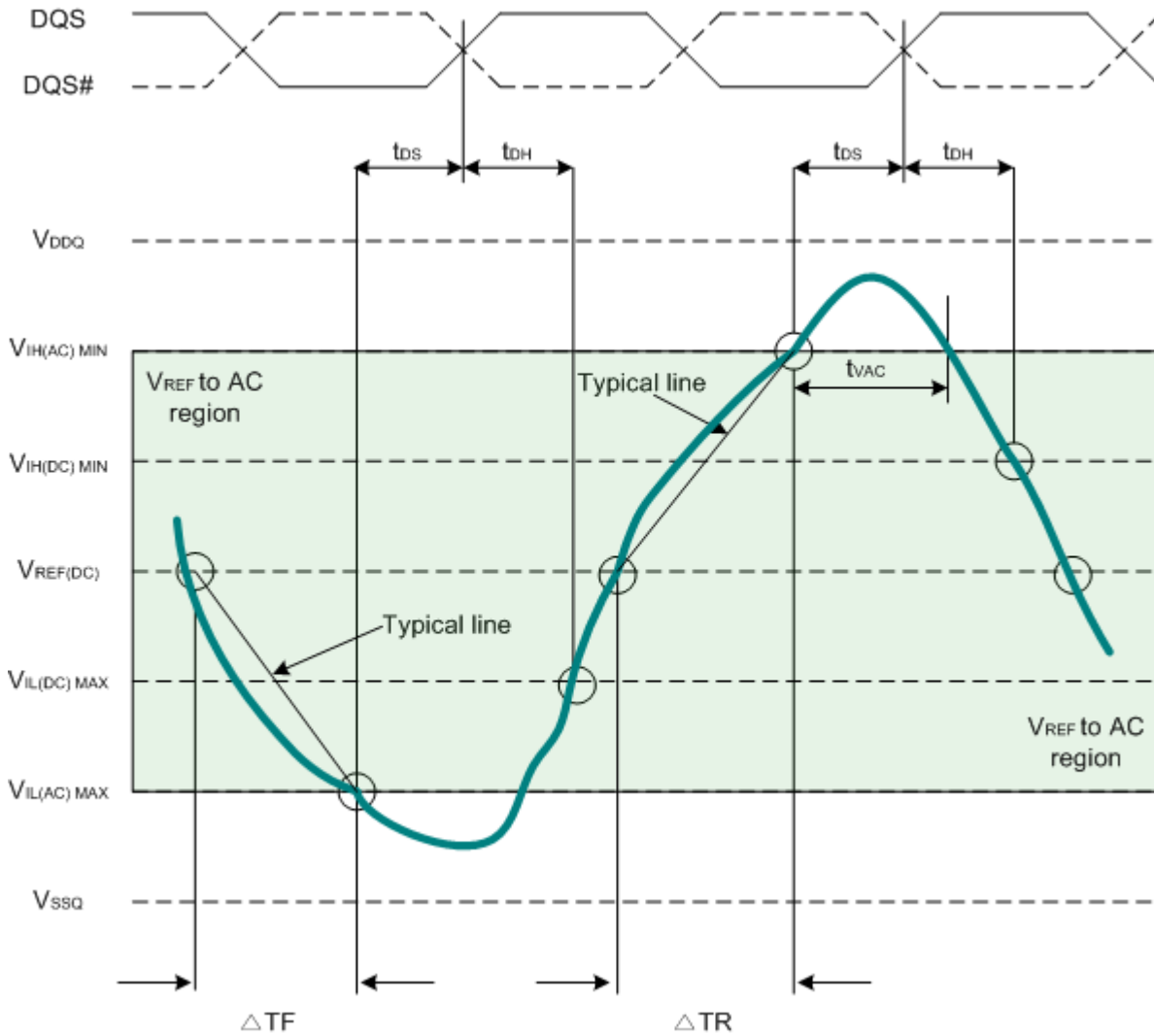
Table 90: Derating Values for AC/DC-Based t_{DS}/t_{DH} (AC300)
 Δt_{DS} , Δt_{DH} derating in ps

| | | DQS, DQS# Differential Slew Rate | | | | | | | | | | | | | | | |
|-----------------------------------|-----|----------------------------------|-----------------|-----------------|-----------------|-----------------|-----------------|-----------------|-----------------|-----------------|-----------------|-----------------|-----------------|-----------------|-----------------|-----------------|-----------------|
| | | 4.0V/ns | | 3.0V/ns | | 2.0V/ns | | 1.8V/ns | | 1.6V/ns | | 1.4V/ns | | 1.2V/ns | | 1.0V/ns | |
| | | Δt_{DS} | Δt_{DH} | Δt_{DS} | Δt_{DH} | Δt_{DS} | Δt_{DH} | Δt_{DS} | Δt_{DH} | Δt_{DS} | Δt_{DH} | Δt_{DS} | Δt_{DH} | Δt_{DS} | Δt_{DH} | Δt_{DS} | Δt_{DH} |
| DQ, DM slew rate V/ns | 2.0 | 150 | 100 | 150 | 100 | 150 | 100 | | | | | | | | | | |
| | 1.5 | 100 | 67 | 100 | 67 | 100 | 67 | 116 | 83 | | | | | | | | |
| | 1.0 | 0 | 0 | 0 | 0 | 0 | 0 | 16 | 16 | 32 | 32 | | | | | | |
| | 0.9 | | | -4 | -8 | -4 | -8 | 12 | 8 | 28 | 24 | 44 | 40 | | | | |
| | 0.8 | | | | | -12 | -20 | 4 | -4 | 20 | 12 | 36 | 28 | 52 | 48 | | |
| | 0.7 | | | | | | | -3 | -18 | 13 | -2 | 29 | 14 | 45 | 34 | 61 | 66 |
| | 0.6 | | | | | | | | | 2 | -21 | 18 | -5 | 34 | 15 | 50 | 47 |
| | 0.5 | | | | | | | | | | | -12 | -32 | 4 | -12 | 20 | 20 |
| | 0.4 | | | | | | | | | | | | 4 | -35 | -40 | -11 | -8 |

Note : 1. Shaded cells are not supported.

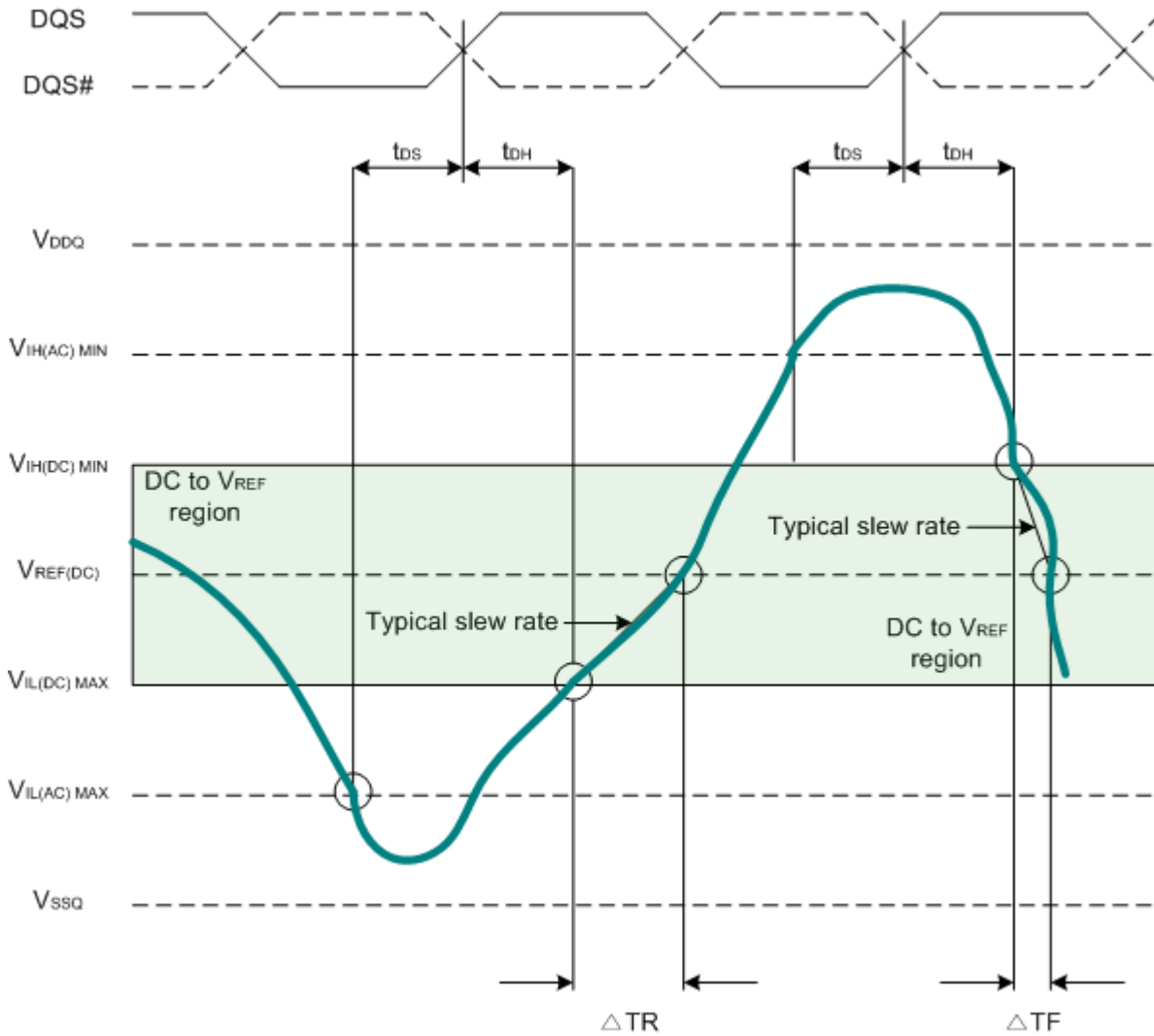
Table 91: Required Time for Valid Transition – $t_{VAC} > V_{IH(AC)}$ or $< V_{IL(AC)}$

| Slew Rate (V/ns) | tVAC at 300mV(ps) | | tVAC at 220mV(ps) | |
|------------------|-------------------|-----|-------------------|-----|
| | Min | Max | Min | Max |
| >2.0 | 75 | - | 175 | - |
| 2.0 | 57 | - | 170 | - |
| 1.5 | 50 | - | 167 | - |
| 1.0 | 38 | - | 163 | - |
| 0.9 | 34 | - | 162 | - |
| 0.8 | 29 | - | 161 | - |
| 0.7 | 22 | - | 159 | - |
| 0.6 | 13 | - | 155 | - |
| 0.5 | 0 | - | 150 | - |
| <0.5 | 0 | - | 150 | - |

Figure 75: Typical Slew Rate and tVAC – tDS for DQ Relative to Strobe


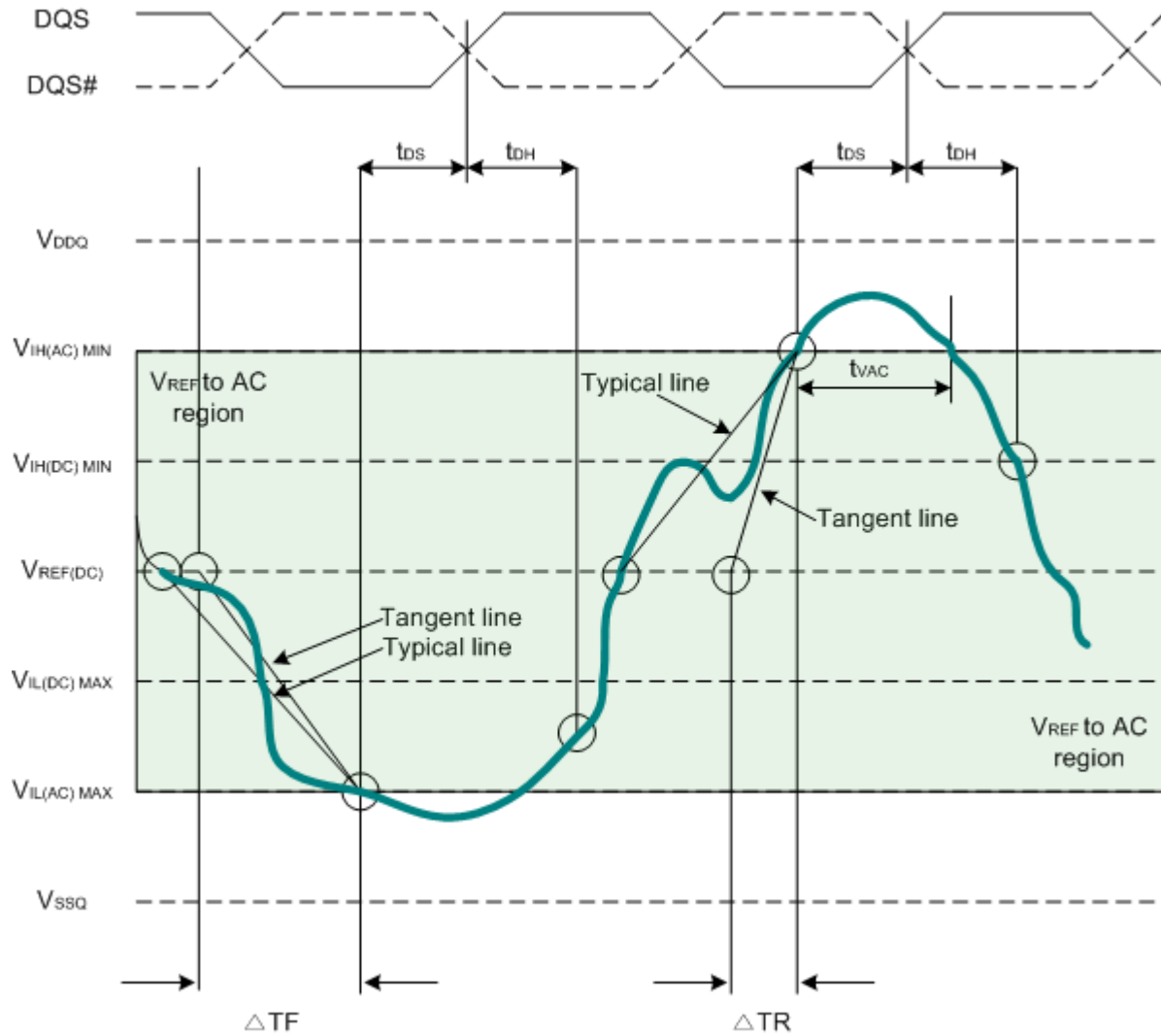
Setup slew rate falling signal = $\frac{V_{REF(DC)} - V_{IL(AC)max}}{\Delta TF}$

Setup slew rate rising signal = $\frac{V_{IH(AC)min} - V_{REF(DC)}}{\Delta TR}$

Figure 76: Typical Slew Rate – t_{DH} for DQ Relative to Strobe


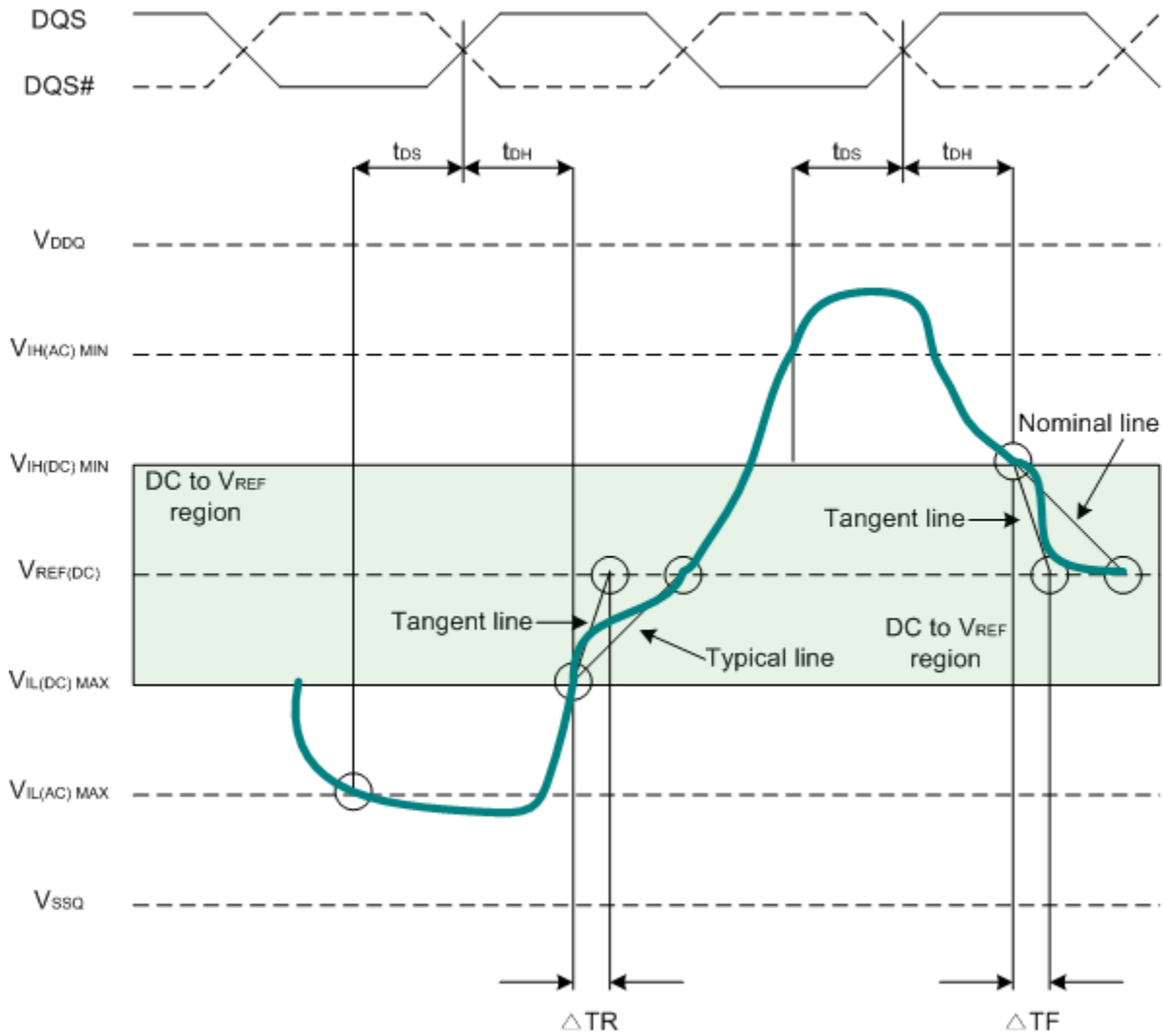
$$\text{Hold slew rate falling signal} = \frac{V_{IH(DC)min} - V_{REF(DC)}}{\Delta TF}$$

$$\text{Hold slew rate rising signal} = \frac{V_{REF(DC)} - V_{IL(DC)max}}{\Delta TR}$$

Figure 77: Tangent Line – tDS for DQ with Respect to Strobe


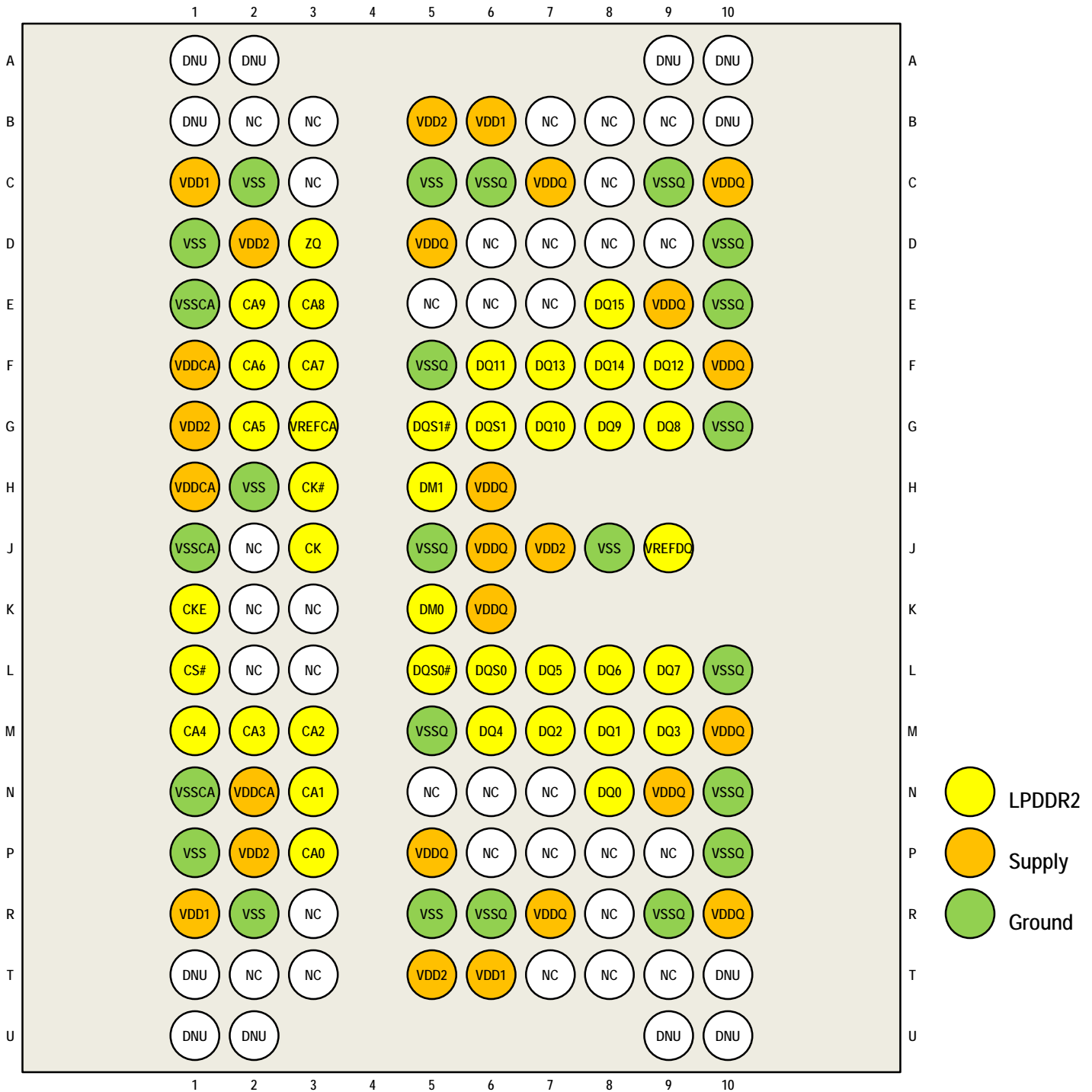
$$\text{Setup slew rate falling signal} = \frac{\text{tangent line } [V_{REF(DC)} - V_{IL(AC)max}]}{\Delta TF}$$

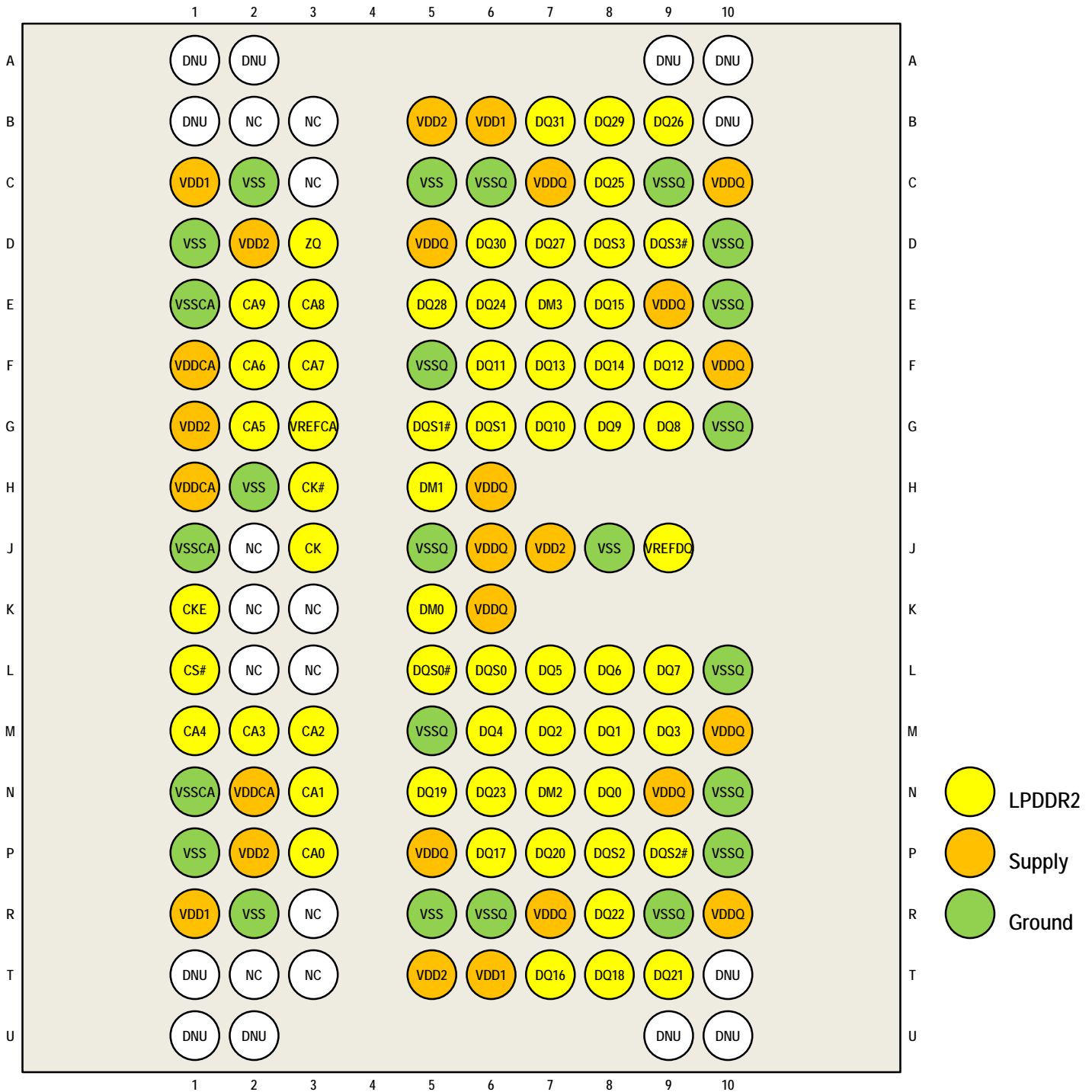
$$\text{Setup slew rate rising signal} = \frac{\text{tangent line } [V_{IH(AC)min} - V_{REF(DC)}]}{\Delta TR}$$

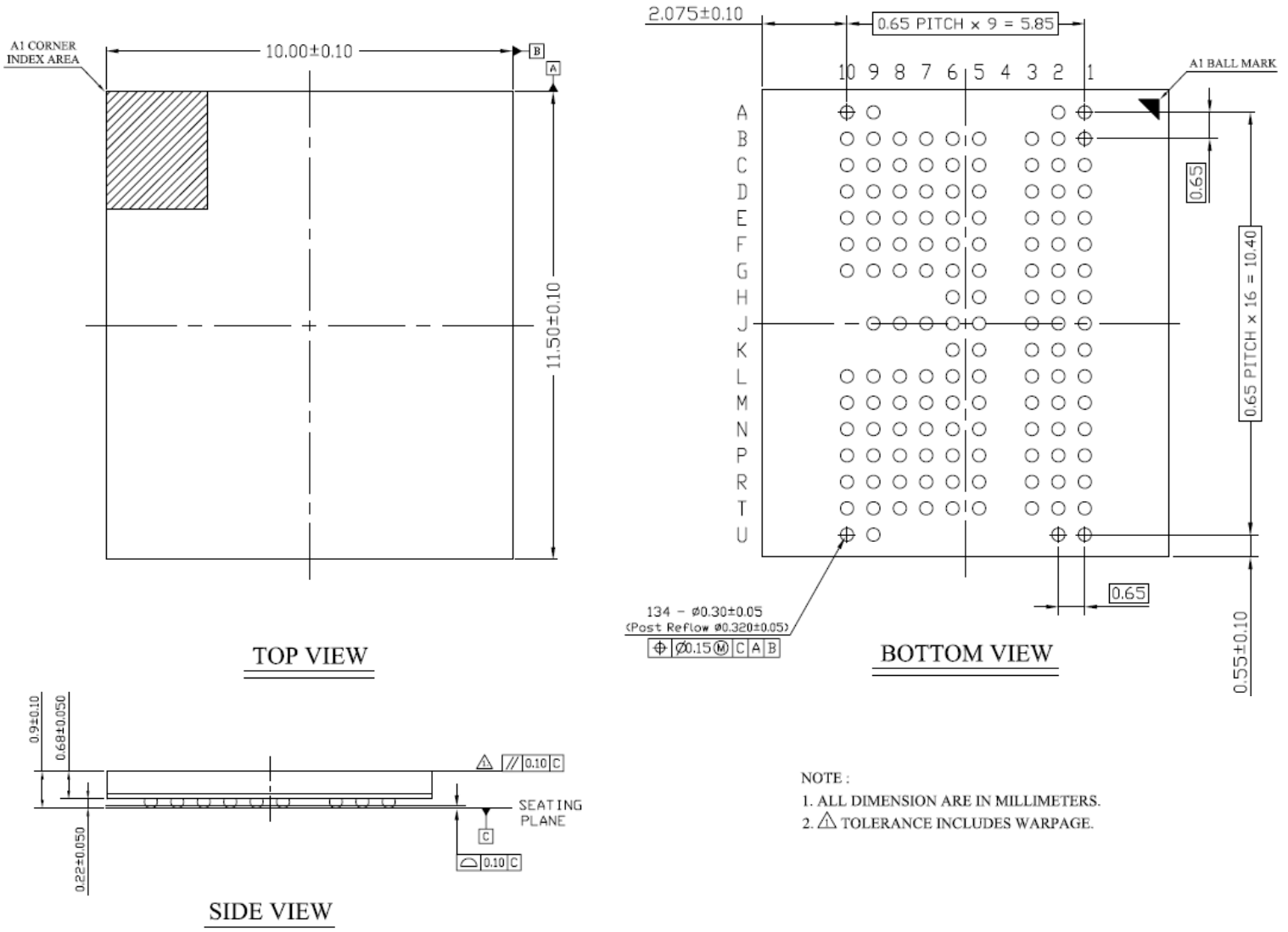
Figure 78: Tangent Line – t_{DH} for DQ with Respect to Strobe


$$\text{Hold slew rate falling signal} = \frac{\text{tangent line } [V_{IH(DC)min} - V_{REF(DC)}]}{\Delta TF}$$

$$\text{Hold slew rate rising signal} = \frac{\text{tangent line } [V_{REF(DC)} - V_{IL(DC)max}]}{\Delta TR}$$

Pin Configuration – 134Ball FBGA(X16)

Top View (Ball Down)

Pin Configuration – 134Ball FBGA(X32)

Top View (Ball Down)

Package Dimension – 134Ball FBGA


PART NUMBERING SYSTEM

| AS4C | 128M16MD2A | -25 | B | I | N | XX |
|------|---|-----------|----------|---------------------------------|----------------------------------|--------------------------------------|
| DRAM | 128M16=128Mx16 MD2= Mobile DDR2 A = A die | 25=400MHz | B = FBGA | I=Industrial (-40° C~+85° C) | Indicates Pb and Halogen Free | Packing Type None:Tray TR:Reel |

| AS4C | 64M32MD2A | -25 | B | I | N | XX |
|------|---|-----------|----------|---------------------------------|----------------------------------|--------------------------------------|
| DRAM | 64M32=64Mx32 MD2= Mobile DDR2 A = A die | 25=400MHz | B = FBGA | I=Industrial (-40° C~+85° C) | Indicates Pb and Halogen Free | Packing Type None:Tray TR:Reel |



Alliance Memory, Inc.
 511 Taylor Way,
 San Carlos, CA 94070
 Tel: 650-610-6800
 Fax: 650-620-9211
www.alliancememory.com

Copyright © Alliance Memory
 All Rights Reserved

© Copyright 2007 Alliance Memory, Inc. All rights reserved. Our three-point logo, our name and Intelliwatt are trademarks or registered trademarks of Alliance. All other brand and product names may be the trademarks of their respective companies. Alliance reserves the right to make changes to this document and its products at any time without notice. Alliance assumes no responsibility for any errors that may appear in this document. The data contained herein represents Alliance's best data and/or estimates at the time of issuance. Alliance reserves the right to change or correct this data at any time, without notice. If the product described herein is under development, significant changes to these specifications are possible. The information in this product data sheet is intended to be general descriptive information for potential customers and users, and is not intended to operate as, or provide, any guarantee or warranty to any user or customer. Alliance does not assume any responsibility or liability arising out of the application or use of any product described herein, and disclaims any express or implied warranties related to the sale and/or use of Alliance products including liability or warranties related to fitness for a particular purpose, merchantability, or infringement of any intellectual property rights, except as express agreed to in Alliance's Terms and Conditions of Sale (which are available from Alliance). All sales of Alliance products are made exclusively according to Alliance's Terms and Conditions of Sale. The purchase of products from Alliance does not convey a license under any patent rights, copyrights; mask works rights, trademarks, or any other intellectual property rights of Alliance or third parties. Alliance does not authorize its products for use as critical components in life-supporting systems where a malfunction or failure may reasonably be expected to result in significant injury to the user, and the inclusion of Alliance products in such life-supporting systems implies that the manufacturer assumes all risk of such use and agrees to indemnify Alliance against all claims arising from such use.

Looking for pricing, stock, or lifecycle information?

Click below to explore more details on WIN SOURCE:

- ⊖ [View AS4C128M16MD2A-25BIN on WIN SOURCE](#)
- ⊖ [Alliance Memory, Inc. Information](#)

Optimize Your Supply Chain with WIN SOURCE Solutions

- ✓ Global Sourcing Solution
- ✓ Obsolete Management
- ✓ Cost Control Management
- ✓ Shortage Management
- ✓ Alternative Solution
- ✓ Excess Inventory Management