

Automotive Mobile LPDDR2 SDRAM

EDB5432BEBH, EDB5432BEPA

Features¹

- Ultra low-voltage core and I/O power supplies
 - $V_{DD2} = 1.14\text{--}1.30\text{V}$
 - $V_{DDCA}/V_{DDQ} = 1.14\text{--}1.30\text{V}$
 - $V_{DD1} = 1.70\text{--}1.95\text{V}$
- Clock frequency range
 - 533–10 MHz (data rate range: 1066–20 Mb/s/pin)
- Four-bit prefetch DDR architecture
- Four internal banks for concurrent operation
- Multiplexed, double data rate, command/address inputs; commands entered on every CK edge
- Bidirectional/differential data strobe per byte of data (DQS/DQS#)
- Programmable READ and WRITE latencies (RL/WL)
- Programmable burst lengths: 4, 8, or 16
- On-chip temperature sensor to control self refresh rate
- Partial-array self refresh (PASR)²
- Deep power-down mode (DPD)
- Selectable output drive strength (DS)
- Clock stop capability
- RoHS-compliant, “green” packaging

Options

- V_{DD2} : 1.2V
- Density/Page Size
 - 512Mb/2KB - single die
- Organization
 - x32
- FBGA “green” package
 - 134-ball VFBGA (10mm x 11.5mm)
 - 168-ball WFBGA (12mm x 12mm)
- Timing – cycle time
 - 1.875ns @ RL = 8
- Special options
 - Standard
 - Automotive certified (Package-level burn-in)
- Operating temperature range
 - From –40°C to +85°C
 - From –40°C to +105°C
 - From –40°C to +125°C
- Revision

Marking

- B
- 54
- 32
- BH
- PA
- 1D
- None
- A
- IT
- AT
- UT³
- :E

Table 1: Key Timing Parameters

Speed Grade	Clock Rate (MHz)	Data Rate (Mb/s/pin)	RL	WL	t _{RCD} /t _{RP}
-1D	533	1066	8	4	Typical

- Notes:
1. All items related to 8-bank in this data sheet are not available. For example per-bank refresh option is not supported.
 2. When $T_c > 105^\circ\text{C}$, self-refresh mode is not available.
 3. UT option use based on automotive usage model. Please contact Micron sales representative if you have questions.

Table 2: Single Channel S4 Configuration Addressing

Architecture	16 Meg x 32
Die configuration	4 Meg x 32 x 4 banks
Row addressing	8K (A[12:0])
Column addressing	512 (A[8:0])
Number of die	1
Die per rank	1
Ranks per channel ¹	1

Note: 1. A channel is a complete LPDRAM interface, including command/address and data pins.

Figure 1: 512Mb LPDDR2 Part Numbering

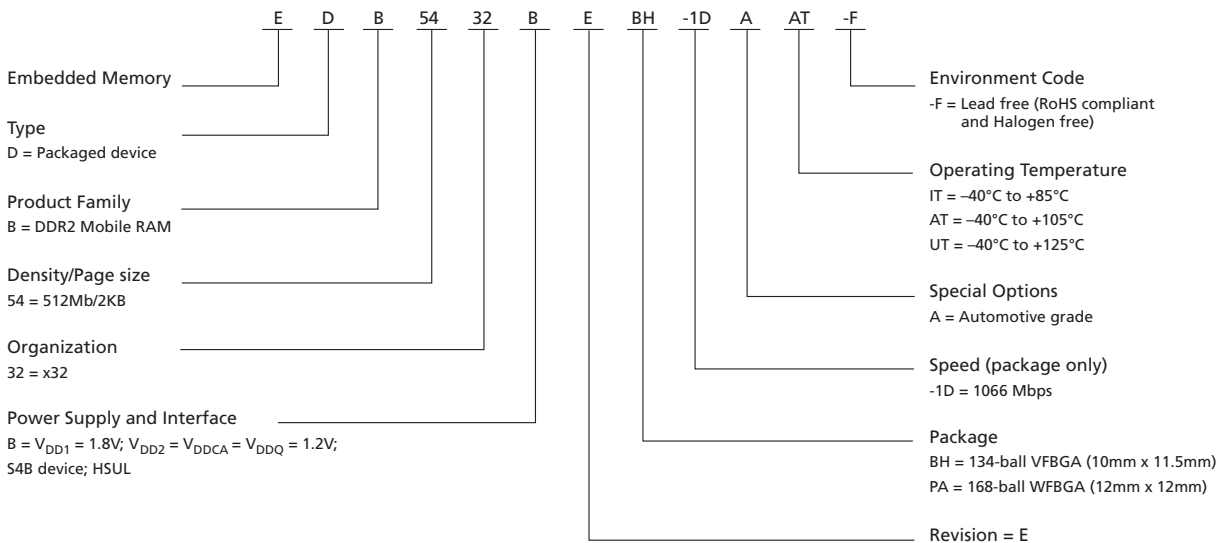

FBGA Part Marking Decoder

Due to space limitations, FBGA-packaged components have an abbreviated part marking that is different from the part number. Micron's FBGA part marking decoder is available at www.micron.com/decoder.

Table 3: Package Codes and Descriptions

Package Code	Ball Count	# Ranks	# Channels	Size (mm)	Die per Package	Solder Ball Composition
BH	134	1	1	10 x 11.5 x 1.0, 0.65 pitch	SDP	SAC302
PA	168	1	1	12 x 12 x 0.8, 0.5 pitch	SDP	SAC302

- Notes: 1. SDP = Single-die package.
2. Solder ball material: SAC302 (96.8% Sn, 3% Ag, 0.2% Cu).

Contents

General Description	9
General Notes	9
I _{DD} Specifications	10
Package Block Diagrams	13
Package Dimensions	14
Ball Assignments and Descriptions	16
Functional Description	19
Power-Up	20
Initialization After RESET (Without Voltage Ramp)	22
Power-Off	22
Uncontrolled Power-Off	23
Mode Register Definition	23
Mode Register Assignments and Definitions	23
ACTIVATE Command	34
Read and Write Access Modes	34
Burst READ Command	34
READs Interrupted by a READ	41
Burst WRITE Command	41
WRITEs Interrupted by a WRITE	44
BURST TERMINATE Command	44
Write Data Mask	46
PRECHARGE Command	47
READ Burst Followed by PRECHARGE	48
WRITE Burst Followed by PRECHARGE	49
Auto Precharge	50
READ Burst with Auto Precharge	50
WRITE Burst with Auto Precharge	51
REFRESH Command	53
REFRESH Requirements	59
SELF REFRESH Operation	61
Partial-Array Self Refresh – Bank Masking	62
Partial-Array Self Refresh – Segment Masking	63
MODE REGISTER READ	64
Temperature Sensor	66
DQ Calibration	68
MODE REGISTER WRITE Command	70
MRW RESET Command	70
MRW ZQ Calibration Commands	71
ZQ External Resistor Value, Tolerance, and Capacitive Loading	73
Power-Down	73
Deep Power-Down	80
Input Clock Frequency Changes and Stop Events	81
Input Clock Frequency Changes and Clock Stop with CKE LOW	81
Input Clock Frequency Changes and Clock Stop with CKE HIGH	82
NO OPERATION Command	82
Simplified Bus Interface State Diagram	82
Truth Tables	84
Electrical Specifications	92
Absolute Maximum Ratings	92
Input/Output Capacitance	92



Electrical Specifications – I _{DD} Specifications and Conditions	93
AC and DC Operating Conditions	96
AC and DC Logic Input Measurement Levels for Single-Ended Signals	98
V _{REF} Tolerances	99
Input Signal	99
AC and DC Logic Input Measurement Levels for Differential Signals	102
Single-Ended Requirements for Differential Signals	103
Differential Input Crosspoint Voltage	105
Input Slew Rate	105
Output Characteristics and Operating Conditions	106
Single-Ended Output Slew Rate	107
Differential Output Slew Rate	108
HSUL ₁₂ Driver Output Timing Reference Load	111
Output Driver Impedance	111
Output Driver Impedance Characteristics with ZQ Calibration	112
Output Driver Temperature and Voltage Sensitivity	113
Output Impedance Characteristics Without ZQ Calibration	113
Clock Specification	117
^t CK(abs), ^t CH(abs), and ^t CL(abs)	118
Clock Period Jitter	118
Clock Period Jitter Effects on Core Timing Parameters	118
Cycle Time Derating for Core Timing Parameters	119
Clock Cycle Derating for Core Timing Parameters	119
Clock Jitter Effects on Command/Address Timing Parameters	119
Clock Jitter Effects on READ Timing Parameters	119
Clock Jitter Effects on WRITE Timing Parameters	120
Refresh Requirements	121
AC Timing	122
CA and CS# Setup, Hold, and Derating	128
Data Setup, Hold, and Slew Rate Derating	135
Revision History	142
Rev. D – 01/16	142
Rev. C – 12/15	142
Rev. B – 10/15	142
Rev. A – 07/15	142

List of Figures

Figure 1: 512Mb LPDDR2 Part Numbering	2
Figure 2: V_{DD1} Typical Self-Refresh Current vs. Temperature	12
Figure 3: V_{DD2} Typical Self-Refresh Current vs. Temperature	12
Figure 4: Single Rank, Single Channel Package Block Diagram	13
Figure 5: 134-Ball VFBGA – 10mm x 11.5mm (Package Code: BH)	14
Figure 6: 168-Ball WFBGA – 12mm x 12mm (Package Code: PA)	15
Figure 7: 134-Ball VFBGA (x32)	16
Figure 8: 168-Ball WFBGA – 12mm x 12mm	17
Figure 9: Functional Block Diagram	19
Figure 10: Voltage Ramp and Initialization Sequence	22
Figure 11: ACTIVATE Command	34
Figure 12: READ Output Timing – $t_{DQSCK}(\text{MAX})$	35
Figure 13: READ Output Timing – $t_{DQSCK}(\text{MIN})$	35
Figure 14: Burst READ – RL = 5, BL = 4, $t_{DQSCK} > t_{CK}$	36
Figure 15: Burst READ – RL = 3, BL = 8, $t_{DQSCK} < t_{CK}$	36
Figure 16: $t_{DQSCKDL}$ Timing	37
Figure 17: $t_{DQSCKDM}$ Timing	38
Figure 18: $t_{DQSCKDS}$ Timing	39
Figure 19: Burst READ Followed by Burst WRITE – RL = 3, WL = 1, BL = 4	40
Figure 20: Seamless Burst READ – RL = 3, BL = 4, $t_{CCD} = 2$	40
Figure 21: READ Burst Interrupt Example – RL = 3, BL = 8, $t_{CCD} = 2$	41
Figure 22: Data Input (WRITE) Timing	42
Figure 23: Burst WRITE – WL = 1, BL = 4	42
Figure 24: Burst WRITE Followed by Burst READ – RL = 3, WL = 1, BL = 4	43
Figure 25: Seamless Burst WRITE – WL = 1, BL = 4, $t_{CCD} = 2$	43
Figure 26: WRITE Burst Interrupt Timing – WL = 1, BL = 8, $t_{CCD} = 2$	44
Figure 27: Burst WRITE Truncated by BST – WL = 1, BL = 16	45
Figure 28: Burst READ Truncated by BST – RL = 3, BL = 16	46
Figure 29: Data Mask Timing	46
Figure 30: Write Data Mask – Second Data Bit Masked	47
Figure 31: READ Burst Followed by PRECHARGE – RL = 3, BL = 8, $RU(t_{RTP}(\text{MIN})/t_{CK}) = 2$	48
Figure 32: READ Burst Followed by PRECHARGE – RL = 3, BL = 4, $RU(t_{RTP}(\text{MIN})/t_{CK}) = 3$	49
Figure 33: WRITE Burst Followed by PRECHARGE – WL = 1, BL = 4	50
Figure 34: READ Burst with Auto Precharge – RL = 3, BL = 4, $RU(t_{RTP}(\text{MIN})/t_{CK}) = 2$	51
Figure 35: WRITE Burst with Auto Precharge – WL = 1, BL = 4	52
Figure 36: Regular Distributed Refresh Pattern	56
Figure 37: Supported Transition from Repetitive REFRESH Burst	57
Figure 38: Nonsupported Transition from Repetitive REFRESH Burst	58
Figure 39: Recommended Self Refresh Entry and Exit	59
Figure 40: t_{SRF} Definition	60
Figure 41: All-Bank REFRESH Operation	61
Figure 42: SELF REFRESH Operation	62
Figure 43: MRR Timing – RL = 3, $t_{MRR} = 2$	64
Figure 44: READ to MRR Timing – RL = 3, $t_{MRR} = 2$	65
Figure 45: Burst WRITE Followed by MRR – RL = 3, WL = 1, BL = 4	66
Figure 46: Temperature Sensor Timing	68
Figure 47: MR32 and MR40 DQ Calibration Timing – RL = 3, $t_{MRR} = 2$	69
Figure 48: MODE REGISTER WRITE Timing – RL = 3, $t_{MRW} = 5$	70
Figure 49: ZQ Timings	72
Figure 50: Power-Down Entry and Exit Timing	74



Figure 51: CKE Intensive Environment	74
Figure 52: REFRESH-to-REFRESH Timing in CKE Intensive Environments	74
Figure 53: READ to Power-Down Entry	75
Figure 54: READ with Auto Precharge to Power-Down Entry	76
Figure 55: WRITE to Power-Down Entry	77
Figure 56: WRITE with Auto Precharge to Power-Down Entry	78
Figure 57: REFRESH Command to Power-Down Entry	79
Figure 58: ACTIVATE Command to Power-Down Entry	79
Figure 59: PRECHARGE Command to Power-Down Entry	79
Figure 60: MRR Command to Power-Down Entry	80
Figure 61: MRW Command to Power-Down Entry	80
Figure 62: Deep Power-Down Entry and Exit Timing	81
Figure 63: Simplified Bus Interface State Diagram	83
Figure 64: V_{REF} DC Tolerance and V_{REF} AC Noise Limits	99
Figure 65: LPDDR2-466 to LPDDR2-1066 Input Signal	100
Figure 66: LPDDR2-200 to LPDDR2-400 Input Signal	101
Figure 67: Differential AC Swing Time and t_{DVAC}	102
Figure 68: Single-Ended Requirements for Differential Signals	104
Figure 69: V_{IX} Definition	105
Figure 70: Differential Input Slew Rate Definition for CK, CK#, DQS, and DQS#	106
Figure 71: Single-Ended Output Slew Rate Definition	107
Figure 72: Differential Output Slew Rate Definition	109
Figure 73: Overshoot and Undershoot Definition	110
Figure 74: HSUL ₁₂ Driver Output Reference Load for Timing and Slew Rate	111
Figure 75: Output Driver	112
Figure 76: Output Impedance = 240 Ohms, I-V Curves After ZQRESET	115
Figure 77: Output Impedance = 240 Ohms, I-V Curves After Calibration	116
Figure 78: Command Input Setup and Hold Timing	128
Figure 79: Typical Slew Rate and $t_{VAC} - t_{IS}$ for CA and CS# Relative to Clock	131
Figure 80: Typical Slew Rate - t_{IH} for CA and CS# Relative to Clock	132
Figure 81: Tangent Line - t_{IS} for CA and CS# Relative to Clock	133
Figure 82: Tangent Line - t_{IH} for CA and CS# Relative to Clock	134
Figure 83: Typical Slew Rate and $t_{VAC} - t_{DS}$ for DQ Relative to Strobe	138
Figure 84: Typical Slew Rate - t_{DH} for DQ Relative to Strobe	139
Figure 85: Tangent Line - t_{DS} for DQ with Respect to Strobe	140
Figure 86: Tangent Line - t_{DH} for DQ with Respect to Strobe	141

List of Tables

Table 1: Key Timing Parameters	1
Table 2: Single Channel S4 Configuration Addressing	2
Table 3: Package Codes and Descriptions	2
Table 4: 16 Meg x 32 I _{DD} Specifications	10
Table 5: I _{DD6} Partial-Array Self Refresh Current	11
Table 6: Ball/Pad Descriptions	18
Table 7: Initialization Timing Parameters	22
Table 8: Power-Off Timing	23
Table 9: Mode Register Assignments	24
Table 10: MR0 Device Information (MA[7:0] = 00h)	25
Table 11: MR0 Op-Code Bit Definitions	25
Table 12: MR1 Device Feature 1 (MA[7:0] = 01h)	25
Table 13: MR1 Op-Code Bit Definitions	26
Table 14: Burst Sequence by Burst Length (BL), Burst Type (BT), and Wrap Control (WC)	26
Table 15: No-Wrap Restrictions	27
Table 16: MR2 Device Feature 2 (MA[7:0] = 02h)	27
Table 17: MR2 Op-Code Bit Definitions	28
Table 18: MR3 I/O Configuration 1 (MA[7:0] = 03h)	28
Table 19: MR3 Op-Code Bit Definitions	28
Table 20: MR4 Device Temperature (MA[7:0] = 04h)	28
Table 21: MR4 Op-Code Bit Definitions	29
Table 22: MR5 Basic Configuration 1 (MA[7:0] = 05h)	29
Table 23: MR5 Op-Code Bit Definitions	29
Table 24: MR6 Basic Configuration 2 (MA[7:0] = 06h)	30
Table 25: MR6 Op-Code Bit Definitions	30
Table 26: MR7 Basic Configuration 3 (MA[7:0] = 07h)	30
Table 27: MR7 Op-Code Bit Definitions	30
Table 28: MR8 Basic Configuration 4 (MA[7:0] = 08h)	30
Table 29: MR8 Op-Code Bit Definitions	30
Table 30: MR9 Test Mode (MA[7:0] = 09h)	31
Table 31: MR10 Calibration (MA[7:0] = 0Ah)	31
Table 32: MR10 Op-Code Bit Definitions	31
Table 33: MR[11:15] Reserved (MA[7:0] = 0Bh–0Fh)	32
Table 34: MR16 PASR Bank Mask (MA[7:0] = 010h)	32
Table 35: MR16 Op-Code Bit Definitions	32
Table 36: MR17 PASR Segment Mask (MA[7:0] = 011h)	32
Table 37: MR17 PASR Segment Mask Definitions	32
Table 38: MR17 PASR Row Address Ranges in Masked Segments	32
Table 39: Reserved Mode Registers	33
Table 40: MR63 RESET (MA[7:0] = 3Fh) – MRW Only	33
Table 41: Bank Selection for PRECHARGE by Address Bits	47
Table 42: PRECHARGE and Auto Precharge Clarification	52
Table 43: REFRESH Command Scheduling Separation Requirements	54
Table 44: Bank and Segment Masking Example	63
Table 45: Temperature Sensor Definitions and Operating Conditions	67
Table 46: Data Calibration Pattern Description	69
Table 47: Truth Table for MRR and MRW	70
Table 48: Command Truth Table	84
Table 49: CKE Truth Table	85
Table 50: Current State Bank <i>n</i> to Command to Bank <i>n</i> Truth Table	86



Table 51: Current State Bank <i>n</i> to Command to Bank <i>m</i> Truth Table	88
Table 52: DM Truth Table	91
Table 53: Absolute Maximum DC Ratings	92
Table 54: Input/Output Capacitance	92
Table 55: Switching for CA Input Signals	93
Table 56: Switching for I _{DD4R}	94
Table 57: Switching for I _{DD4W}	94
Table 58: I _{DD} Specification Parameters and Operating Conditions	95
Table 59: Recommended DC Operating Conditions	96
Table 60: Input Leakage Current	97
Table 61: Operating Temperature Range	97
Table 62: Single-Ended AC and DC Input Levels for CA and CS# Inputs	98
Table 63: Single-Ended AC and DC Input Levels for CKE	98
Table 64: Single-Ended AC and DC Input Levels for DQ and DM	98
Table 65: Differential AC and DC Input Levels	102
Table 66: CK/CK# and DQS/DQS# Time Requirements Before Ringback (^t DVAC)	103
Table 67: Single-Ended Levels for CK, CK#, DQS, DQS#	104
Table 68: Crosspoint Voltage for Differential Input Signals (CK, CK#, DQS, DQS#)	105
Table 69: Differential Input Slew Rate Definition	106
Table 70: Single-Ended AC and DC Output Levels	106
Table 71: Differential AC and DC Output Levels	107
Table 72: Single-Ended Output Slew Rate Definition	107
Table 73: Single-Ended Output Slew Rate	107
Table 74: Differential Output Slew Rate Definition	108
Table 75: Differential Output Slew Rate	109
Table 76: AC Overshoot/Undershoot Specification	109
Table 77: Output Driver DC Electrical Characteristics with ZQ Calibration	112
Table 78: Output Driver Sensitivity Definition	113
Table 79: Output Driver Temperature and Voltage Sensitivity	113
Table 80: Output Driver DC Electrical Characteristics Without ZQ Calibration	113
Table 81: I-V Curves	114
Table 82: Definitions and Calculations	117
Table 83: ^t CK(abs), ^t CH(abs), and ^t CL(abs) Definitions	118
Table 84: Refresh Requirement Parameters (Per Density)	121
Table 85: AC Timing	122
Table 86: CA and CS# Setup and Hold Base Values (>400 MHz, 1 V/ns Slew Rate)	129
Table 87: CA and CS# Setup and Hold Base Values (<400 MHz, 1 V/ns Slew Rate)	129
Table 88: Derating Values for AC/DC-Based ^t IS/ ^t IH (AC220)	130
Table 89: Derating Values for AC/DC-Based ^t IS/ ^t IH (AC300)	130
Table 90: Required Time for Valid Transition – ^t VAC > V _{IH(AC)} and < V _{IL(AC)}	130
Table 91: Data Setup and Hold Base Values (>400 MHz, 1 V/ns Slew Rate)	135
Table 92: Data Setup and Hold Base Values (<400 MHz, 1 V/ns Slew Rate)	136
Table 93: Derating Values for AC/DC-Based ^t DS/ ^t DH (AC220)	136
Table 94: Derating Values for AC/DC-Based ^t DS/ ^t DH (AC300)	137
Table 95: Required Time for Valid Transition – ^t VAC > V _{IH(AC)} or < V _{IL(AC)}	137

General Description

The 512Mb Mobile Low-Power DDR2 SDRAM (LPDDR2) is a high-speed CMOS, dynamic random-access memory containing 536,870,912 bits. The LPDDR2-S4 device is internally configured as an four-bank DRAM. Each of the x32's 134,217,728-bit banks is organized as 8192 rows by 512 columns by 32 bits.

General Notes

Throughout the data sheet, figures and text refer to DQs as "DQ." DQ should be interpreted as any or all DQ collectively, unless specifically stated otherwise.

"DQS" and "CK" should be interpreted as DQS, DQS# and CK, CK# respectively, unless specifically stated otherwise. "BA" includes all BA pins used for a given density.

In timing diagrams, "CMD" is used as an indicator only. Actual signals occur on CA[9:0].

V_{REF} indicates V_{REFCA} and V_{REFDQ} .

Complete functionality may be described throughout the entire document. Any page or diagram may have been simplified to convey a topic and may not be inclusive of all requirements.

Any specific requirement takes precedence over a general statement.

Any functionality not specifically stated herein is considered undefined, illegal, is not supported, and will result in unknown operation.

I_{DD} Specifications

Table 4: 16 Meg x 32 I_{DD} Specifications
 $V_{DD2}, V_{DDQ}, V_{DDCA} = 1.14\text{--}1.30\text{V}; V_{DD1} = 1.70\text{--}1.95\text{V}$

Parameter	Supply	Speed Grade	Unit
		-1D	
I _{DD01}	V _{DD1}	6	mA
I _{DD02}	V _{DD2}	30	
I _{DD0,in}	V _{DDCA} + V _{DDQ}	1	
I _{DD2P1}	V _{DD1}	0.6	mA
I _{DD2P2}	V _{DD2}	1.6	
I _{DD2P,in}	V _{DDCA} + V _{DDQ}	0.1	
I _{DD2PS1}	V _{DD1}	0.6	mA
I _{DD2PS2}	V _{DD2}	1.6	
I _{DD2PS,in}	V _{DDCA} + V _{DDQ}	0.1	
I _{DD2N1}	V _{DD1}	0.6	mA
I _{DD2N2}	V _{DD2}	20	
I _{DD2N,in}	V _{DDCA} + V _{DDQ}	1	
I _{DD2NS1}	V _{DD1}	0.6	mA
I _{DD2NS2}	V _{DD2}	12	
I _{DD2NS,in}	V _{DDCA} + V _{DDQ}	1	
I _{DD3P1}	V _{DD1}	1.4	mA
I _{DD3P2}	V _{DD2}	5	
I _{DD3P,in}	V _{DDCA} + V _{DDQ}	0.1	
I _{DD3PS1}	V _{DD1}	1.4	mA
I _{DD3PS2}	V _{DD2}	5	
I _{DD3PS,in}	V _{DDCA} + V _{DDQ}	0.1	
I _{DD3N1}	V _{DD1}	1.5	mA
I _{DD3N2}	V _{DD2}	22	
I _{DD3N,in}	V _{DDCA} + V _{DDQ}	1	
I _{DD3NS1}	V _{DD1}	1.5	mA
I _{DD3NS2}	V _{DD2}	14	
I _{DD3NS,in}	V _{DDCA} + V _{DDQ}	1	
I _{DD4R1}	V _{DD1}	2	mA
I _{DD4R2}	V _{DD2}	180	
I _{DD4R,in}	V _{DDCA}	2	
I _{DD4W1}	V _{DD1}	2	mA
I _{DD4W2}	V _{DD2}	200	
I _{DD4W,in}	V _{DDCA} + V _{DDQ}	1	

Table 4: 16 Meg x 32 I_{DD} Specifications (Continued)
 $V_{DD2}, V_{DDQ}, V_{DDCA} = 1.14\text{--}1.30\text{V}; V_{DD1} = 1.70\text{--}1.95\text{V}$

Parameter	Supply	Speed Grade	Unit
		-1D	
I _{DD51}	V _{DD1}	20	mA
I _{DD52}	V _{DD2}	70	
I _{DD5,in}	V _{DDCA} + V _{DDQ}	1	
I _{DD5AB1}	V _{DD1}	2	mA
I _{DD5AB2}	V _{DD2}	23	
I _{DD5AB,in}	V _{DDCA} + V _{DDQ}	1	
I _{DD61}	V _{DD1}	–	See Table 5
I _{DD62}	V _{DD2}	–	
I _{DD6,in}	V _{DDCA} + V _{DDQ}	–	
I _{DD81}	V _{DD1}	0.05	mA
I _{DD82}	V _{DD2}	0.05	
I _{DD8,in}	V _{DDCA} + V _{DDQ}	0.02	

Table 5: I_{DD6} Partial-Array Self Refresh Current
 $V_{DD2}, V_{DDQ}, V_{DDCA} = 1.14\text{--}1.30\text{V}; V_{DD1} = 1.70\text{--}1.95\text{V}$

PASR	Supply	Value (-40°C to +85°C)	Value (+85°C to +105°C)	Value (+105°C to +125°C)	Unit
Full array	V _{DD1}	230	2100	–	μA
	V _{DD2}	700	4400	–	
	V _{DDi}	20	20	–	
1/2 array	V _{DD1}	200	2000	–	
	V _{DD2}	500	2900	–	
	V _{DDi}	20	20	–	
1/4 array	V _{DD1}	190	1800	–	
	V _{DD2}	400	2000	–	
	V _{DDi}	20	20	–	
1/8 array	V _{DD1}	185	1700	–	
	V _{DD2}	360	1800	–	
	V _{DDi}	20	20	–	

- Notes: 1. LPDDR2-S4 SDRAM devices support both bank-masking and segment-masking. I_{DD6} PASR currents are measured using bank-masking only.
2. When TC > 105°C: self-refresh mode is not available.

Figure 2: V_{DD1} Typical Self-Refresh Current vs. Temperature

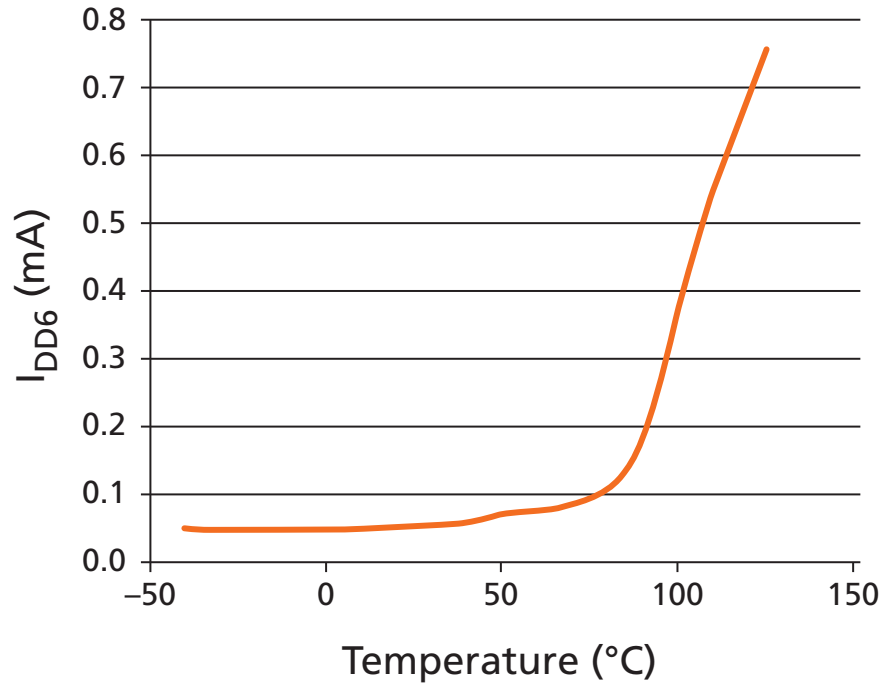
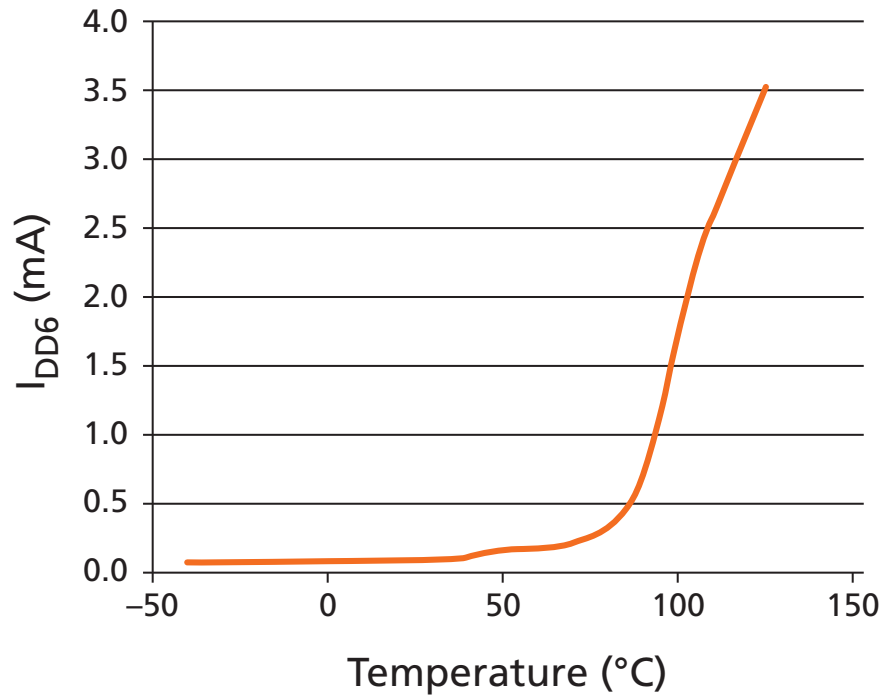
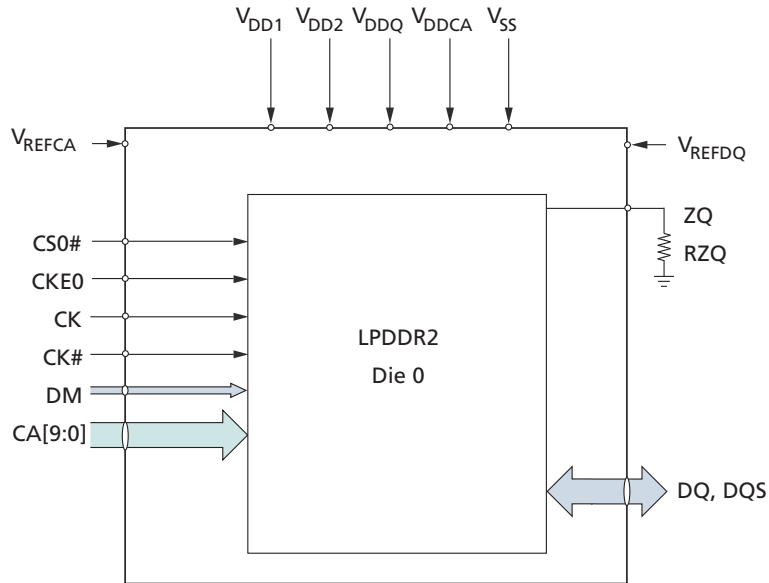

Figure 3: V_{DD2} Typical Self-Refresh Current vs. Temperature



Package Block Diagrams

Figure 4: Single Rank, Single Channel Package Block Diagram



Package Dimensions

Figure 5: 134-Ball VFBGA – 10mm x 11.5mm (Package Code: BH)

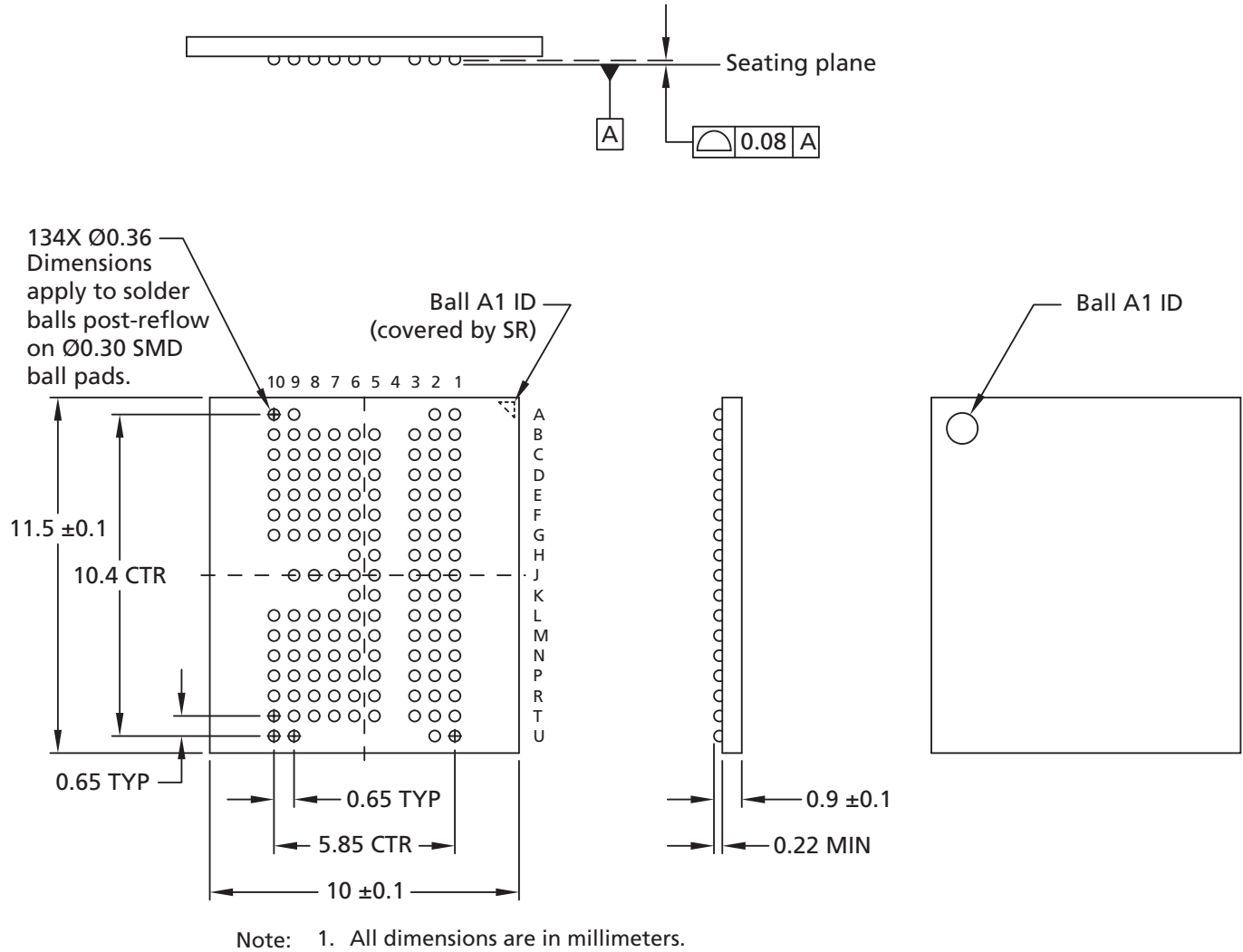
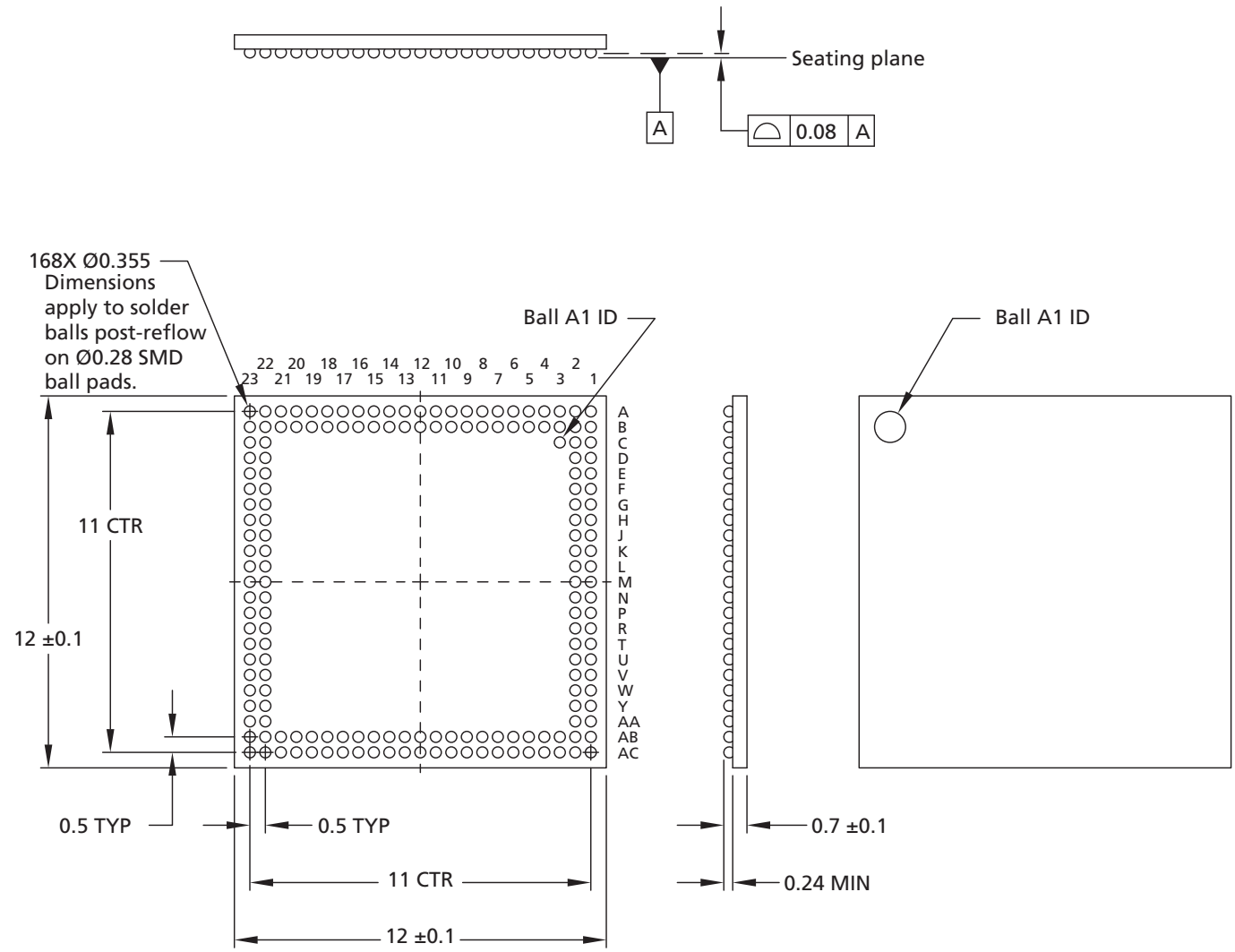

Figure 6: 168-Ball WFBGA – 12mm x 12mm (Package Code: PA)



Note: 1. All dimensions are in millimeters.

Ball Assignments and Descriptions

Figure 7: 134-Ball VFBGA (x32)

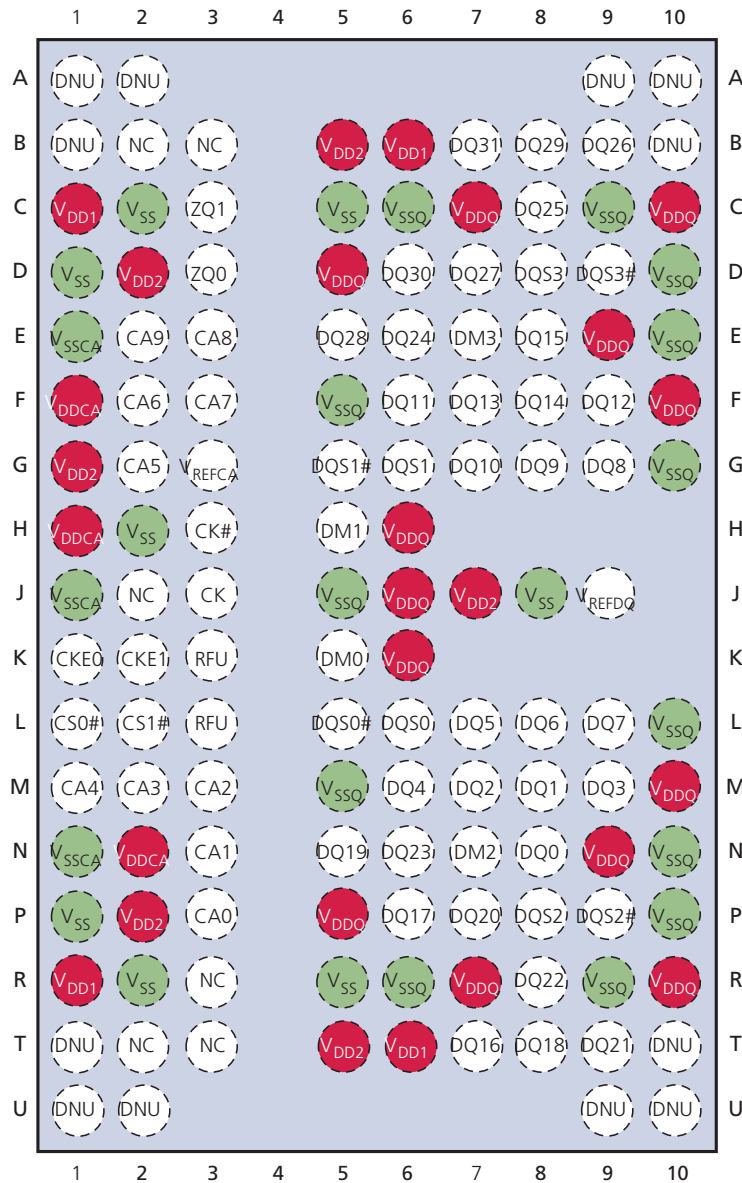

- Notes:
1. CS1#, CKE1, and ZQ1 are reserved for the second rank use.
 2. V_{DDCA} is unnecessary. F1, H1, and N2 pins are no care of the external connection.

Figure 8: 168-Ball WFBGA – 12mm x 12mm

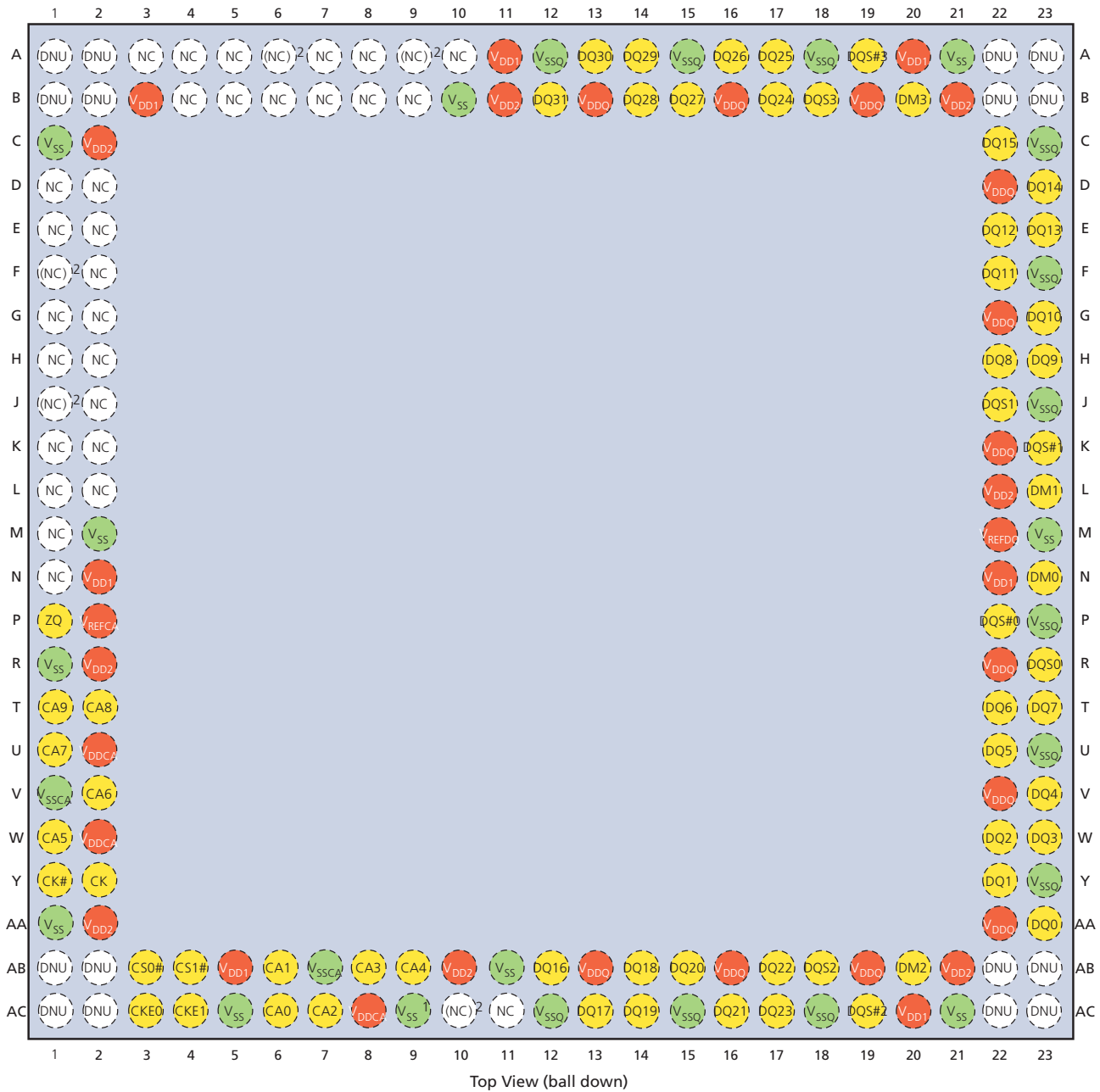

- Notes:
- Ball AC9 may be V_{SS} or left unconnected.
 - Balls labeled NC = no connect; however, they can be connected together internally.
 - CS1# and CKE1 are reserved for the second rank use.
 - V_{DDCA} is unnecessary. U2, W2, and CA8 pins are no care of the external connection.

Table 6: Ball/Pad Descriptions

Symbol	Type	Description
CA[9:0]	Input	Command/address inputs: Provide the command and address inputs according to the command truth table.
CK, CK#	Input	Clock: CK and CK# are differential clock inputs. All CA inputs are sampled on both rising and falling edges of CK. CS and CKE inputs are sampled at the rising edge of CK. AC timings are referenced to clock.
CKE[1:0]	Input	Clock enable: CKE HIGH activates and CKE LOW deactivates the internal clock signals, input buffers, and output drivers. Power-saving modes are entered and exited via CKE transitions. CKE is considered part of the command code. CKE is sampled at the rising edge of CK.
CS[1:0]#	Input	Chip select: CS# is considered part of the command code and is sampled at the rising edge of CK.
DM[3:0]	Input	Input data mask: DM is an input mask signal for write data. Although DM balls are input-only, the DM loading is designed to match that of DQ and DQS balls. DM[3:0] is DM for each of the four data bytes, respectively.
DQ[31:0]	I/O	Data input/output: Bidirectional data bus.
DQS[3:0], DQS[3:0]#	I/O	Data strobe: The data strobe is bidirectional (used for read and write data) and complementary (DQS and DQS#). It is edge-aligned output with read data and centered input with write data. DQS[3:0]/DQS[3:0]# is DQS for each of the four data bytes, respectively.
V _{DDQ}	Supply	DQ power supply: Isolated on the die for improved noise immunity.
V _{SSQ}	Supply	DQ ground: Isolated on the die for improved noise immunity.
V _{DDCA}	Supply	Command/address power supply: Command/address power supply.
V _{SSCA}	Supply	Command/address ground: Isolated on the die for improved noise immunity.
V _{DD1}	Supply	Core power: Supply 1.
V _{DD2}	Supply	Core power: Supply 2.
V _{SS}	Supply	Common ground
V _{REFCA} , V _{REFDQ}	Supply	Reference voltage: V _{REFCA} is reference for command/address input buffers, V _{REFDQ} is reference for DQ input buffers.
ZQ	Reference	External impedance (240 ohm): This signal is used to calibrate the device output impedance.
DNU	–	Do not use: Must be grounded or left floating.
NC	–	No connect: Not internally connected.
(NC)	–	No connect: Balls indicated as (NC) are no connects, however, they could be connected together internally.

Note: 1. CS1# and CKE1 are reserved for the second rank use.

Functional Description

Mobile LPDDR2 is a high-speed SDRAM internally configured as a 4-bank memory device. LPDDR2 devices use a double data rate architecture on the command/address (CA) bus to reduce the number of input pins in the system. The 10-bit CA bus is used to transmit command, address, and bank information. Each command uses one clock cycle, during which command information is transferred on both the rising and falling edges of the clock.

LPDDR2-S4 devices use a double data rate architecture on the DQ pins to achieve high-speed operation. The double data rate architecture is essentially a $4n$ prefetch architecture with an interface designed to transfer two data bits per DQ every clock cycle at the I/O pins. A single read or write access for the LPDDR2-S4 effectively consists of a single $4n$ -bit-wide, one-clock-cycle data transfer at the internal SDRAM core and four corresponding n -bit-wide, one-half-clock-cycle data transfers at the I/O pins.

Read and write accesses are burst oriented; accesses start at a selected location and continue for a programmed number of locations in a programmed sequence.

Accesses begin with the registration of an ACTIVATE command followed by a READ or WRITE command. The address and BA bits registered coincident with the ACTIVATE command are used to select the row and bank to be accessed. The address bits registered coincident with the READ or WRITE command are used to select the bank and the starting column location for the burst access.

Figure 9: Functional Block Diagram

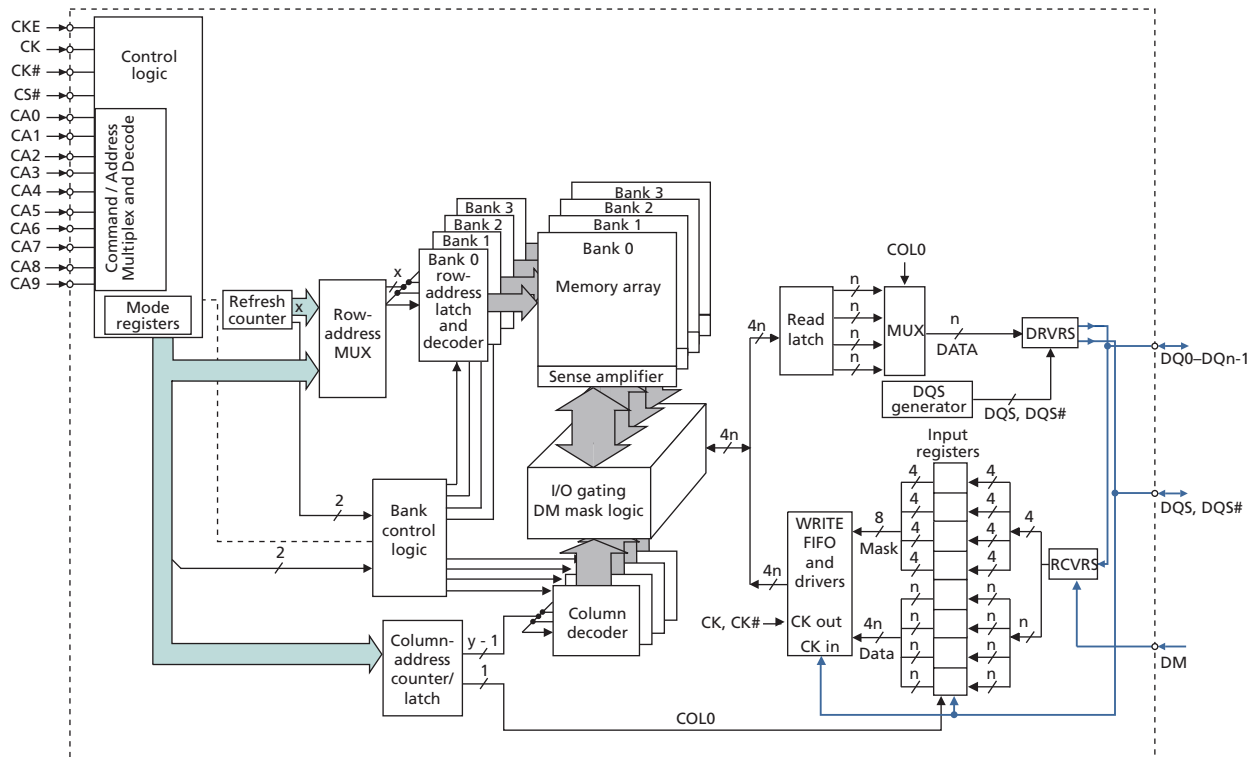

Power-Up

The following sequence must be used to power up the device. Unless specified otherwise, this procedure is mandatory (see Figure 10 (page 22)). Power-up and initialization by means other than those specified will result in undefined operation.

1. Voltage Ramp

While applying power (after T_a), CKE must be held LOW ($\leq 0.2 \times V_{DDCA}$), and all other inputs must be between V_{ILmin} and V_{IHmax} . The device outputs remain at High-Z while CKE is held LOW.

On or before the completion of the voltage ramp (T_b), CKE must be held LOW. DQ, DM, DQS, and DQS# voltage levels must be between V_{SSQ} and V_{DDQ} during voltage ramp to avoid latchup. CK, CK#, CS#, and CA input levels must be between V_{SSCA} and V_{DDCA} during voltage ramp to avoid latchup.

The following conditions apply for voltage ramp:

- T_a is the point when any power supply first reaches 300mV.
- Noted conditions apply between T_a and power-down (controlled or uncontrolled).
- T_b is the point at which all supply and reference voltages are within their defined operating ranges.
- Power ramp duration t_{INIT0} ($T_b - T_a$) must not exceed 20ms.
- For supply and reference voltage operating conditions, see the Recommended DC Operating Conditions table.
- The voltage difference between any of V_{SS} , V_{SSQ} , and V_{SSCA} pins must not exceed 100mV.

Voltage Ramp Completion

After T_a is reached:

- V_{DD1} must be greater than $V_{DD2} - 200mV$
- V_{DD1} and V_{DD2} must be greater than $V_{DDCA} - 200mV$
- V_{DD1} and V_{DD2} must be greater than $V_{DDQ} - 200mV$
- V_{REF} must always be less than all other supply voltages

Beginning at T_b , CKE must remain LOW for at least $t_{INIT1} = 100ns$, after which CKE can be asserted HIGH. The clock must be stable at least $t_{INIT2} = 5 \times t_{CK}$ prior to the first CKE LOW-to-HIGH transition (T_c). CKE, CS#, and CA inputs must observe setup and hold requirements (t_{IS} , t_{IH}) with respect to the first rising clock edge (and to subsequent falling and rising edges).

If any MRRs are issued, the clock period must be within the range defined for t_{CKb} (18ns to 100ns). MRWs can be issued at normal clock frequencies as long as all AC timings are met. Some AC parameters (for example, t_{DQSCK}) could have relaxed timings (such as t_{DQSCKb}) before the system is appropriately configured. While keeping CKE HIGH, NOP commands must be issued for at least $t_{INIT3} = 200\mu s$ (T_d).

2. RESET Command

After t_{INIT3} is satisfied, the MRW RESET command must be issued (T_d). An optional PRECHARGE ALL command can be issued prior to the MRW RESET command.

Wait at least t_{INIT4} while keeping CKE asserted and issuing NOP commands.

3. MRRs and Device Auto Initialization (DAI) Polling

After t_{INIT4} is satisfied (T_e), only MRR commands and power-down entry/exit commands are supported. After T_e , CKE can go LOW in alignment with power-down entry and exit specifications (see Power-Down (page 73)).

The MRR command can be used to poll the DAI bit, which indicates when device auto initialization is complete; otherwise, the controller must wait a minimum of t_{INIT5} , or until the DAI bit is set, before proceeding.

Because the memory output buffers are not properly configured by T_e , some AC parameters must use relaxed timing specifications before the system is appropriately configured.

After the DAI bit (MR0, DAI) is set to zero by the memory device (DAI complete), the device is in the idle state (T_f). DAI status can be determined by issuing the MRR command to MR0.

The device sets the DAI bit no later than t_{INIT5} after the RESET command. The controller must wait at least t_{INIT5} or until the DAI bit is set before proceeding.

4. ZQ Calibration

After t_{INIT5} (T_f), the MRW initialization calibration (ZQ calibration) command can be issued to the memory (MR10).

This command is used to calibrate output impedance over process, voltage, and temperature. In systems where more than one Mobile LPDDR2 device exists on the same bus, the controller must not overlap MRW ZQ calibration commands. The device is ready for normal operation after t_{ZQINIT} .

5. Normal Operation

After (T_g), MRW commands must be used to properly configure the memory (output buffer drive strength, latencies, etc.). Specifically, MR1, MR2, and MR3 must be set to configure the memory for the target frequency and memory configuration.

After the initialization sequence is complete, the device is ready for any valid command. After T_g , the clock frequency can be changed using the procedure described in Input Clock Frequency Changes and Clock Stop with CKE HIGH (page 82).

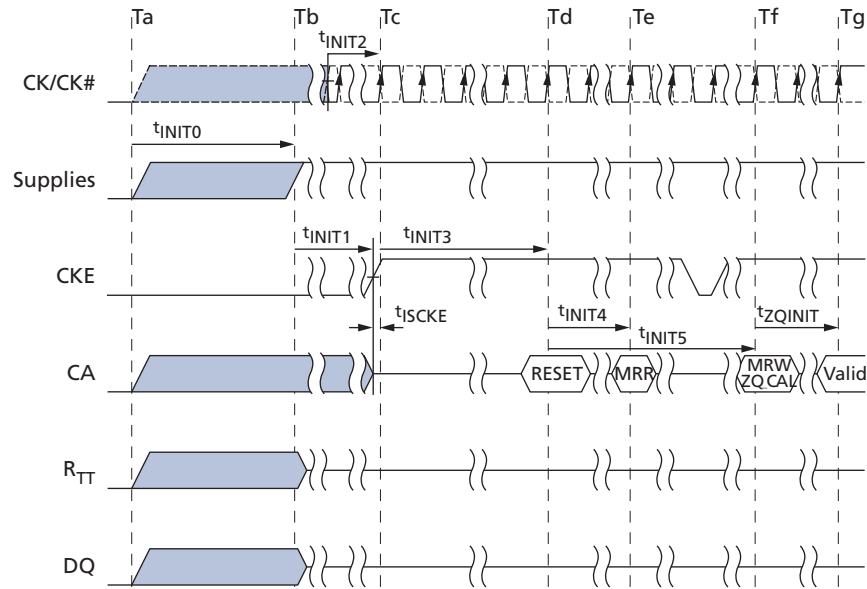
Figure 10: Voltage Ramp and Initialization Sequence

Note: 1. High-Z on the CA bus indicates valid NOP.

Table 7: Initialization Timing Parameters

Parameter	Value		Unit	Comment
	Min	Max		
t_{INIT0}	–	20	ms	Maximum voltage ramp time
t_{INIT1}	100	–	ns	Minimum CKE LOW time after completion of voltage ramp
t_{INIT2}	5	–	t_{CK}	Minimum stable clock before first CKE HIGH
t_{INIT3}	200	–	μs	Minimum idle time after first CKE assertion
t_{INIT4}	1	–	μs	Minimum idle time after RESET command
t_{INIT5}	–	10	μs	Maximum duration of device auto initialization
t_{ZQINIT}	1	–	μs	ZQ initial calibration (S4 devices only)
t_{CKb}	18	100	ns	Clock cycle time during boot

Note: 1. The t_{INIT0} maximum specification is not a tested limit and should be used as a general guideline. For voltage ramp times exceeding t_{INIT0} MAX, please contact the factory.

Initialization After RESET (Without Voltage Ramp)

If the RESET command is issued before or after the power-up initialization sequence, the reinitialization procedure must begin at Td.

Power-Off

While powering off, CKE must be held LOW ($\leq 0.2 \times V_{DDCA}$); all other inputs must be between V_{ILmin} and V_{IHmax} . The device outputs remain at High-Z while CKE is held LOW.

DQ, DM, DQS, and DQS# voltage levels must be between V_{SSQ} and V_{DDQ} during the power-off sequence to avoid latchup. CK, CK#, CS#, and CA input levels must be between V_{SSCA} and V_{DDCA} during the power-off sequence to avoid latchup.

Tx is the point where any power supply drops below the minimum value specified in the Recommended DC Operating Conditions table.

Tz is the point where all power supplies are below 300mV. After Tz, the device is powered off.

Required Power Supply Conditions Between Tx and Tz:

- V_{DD1} must be greater than $V_{DD2} - 200\text{mV}$
- V_{DD1} must be greater than $V_{DDCA} - 200\text{mV}$
- V_{DD1} must be greater than $V_{DDQ} - 200\text{mV}$
- V_{REF} must always be less than all other supply voltages

The voltage difference between V_{SS} , V_{SSQ} , and V_{SSCA} must not exceed 100mV.

For supply and reference voltage operating conditions, see Recommended DC Operating Conditions table.

Uncontrolled Power-Off

When an uncontrolled power-off occurs, the following conditions must be met:

- At Tx, when the power supply drops below the minimum values specified in the Recommended DC Operating Conditions table, all power supplies must be turned off and all power-supply current capacity must be at zero, except for any static charge remaining in the system.
- After Tz (the point at which all power supplies first reach 300mV), the device must power off. The time between Tx and Tz must not exceed t_{POFF} . During this period, the relative voltage between power supplies is uncontrolled. V_{DD1} and V_{DD2} must decrease with a slope lower than $0.5\text{ V}/\mu\text{s}$ between Tx and Tz.

An uncontrolled power-off sequence can occur a maximum of 400 times over the life of the device.

Table 8: Power-Off Timing

Parameter	Symbol	Min	Max	Unit
Maximum power-off ramp time	t_{POFF}	–	2	sec

Mode Register Definition

LPDDR2 devices contain a set of mode registers used for programming device operating parameters, reading device information and status, and for initiating special operations such as DQ calibration, ZQ calibration, and device reset.

Mode Register Assignments and Definitions

The MRR command is used to read from a register. The MRW command is used to write to a register. An “R” in the access column of the mode register assignment table indicates read-only; a “W” indicates write-only; “R/W” indicates read or write capable or enabled.

Table 9: Mode Register Assignments

Notes 1–5 apply to all parameters and conditions

MR#	MA[7:0]	Function	Access	OP7	OP6	OP5	OP4	OP3	OP2	OP1	OP0	Link
0	00h	Device info	R	RFU			RZQI		DNVI	DI	DAI	go to MR0
1	01h	Device feature 1	W	nWR (for AP)			WC	BT	BL			go to MR1
2	02h	Device feature 2	W	RFU			RL and WL					go to MR2
3	03h	I/O config-1	W	RFU			DS					go to MR3
4	04h	SDRAM refresh rate	R	TUF	RFU			Refresh rate				go to MR4
5	05h	Basic config-1	R	LPDDR2 Manufacturer ID								go to MR5
6	06h	Basic config-2	R	Revision ID1								go to MR6
7	07h	Basic config-3	R	Revision ID2								go to MR7
8	08h	Basic config-4	R	I/O width	Density				Type		go to MR8	
9	09h	Test mode	W	Vendor-specific test mode								go to MR9
10	0Ah	I/O calibration	W	Calibration code								go to MR10
11–15	0Bh ~ 0Fh	Reserved	–	RFU								go to MR11
16	10h	PASR_Bank	W	Bank mask								go to MR16
17	11h	PASR_Seg	W	Segment mask								go to MR17
18–19	12h–13h	Reserved	–	RFU								go to MR18
20–31	14h–1Fh	Reserved for NVM										MR20–MR30
32	20h	DQ calibration pattern A	R	See Table 46 (page 69).								go to MR32
33–39	21h–27h	Do not use										go to MR33
40	28h	DQ calibration pattern B	R	See Table 46 (page 69).								go to MR40
41–47	29h–2Fh	Do not use										go to MR41
48–62	30h–3Eh	Reserved	–	RFU								go to MR48
63	3Fh	RESET	W	X								go to MR63
64–126	40h–7Eh	Reserved	–	RFU								go to MR64
127	7Fh	Do not use										go to MR127
128–190	80h–BEh	Reserved for vendor use		RVU								go to MR128
191	BFh	Do not use										go to MR191
192–254	C0h–FEh	Reserved for vendor use		RVU								go to MR192
255	FFh	Do not use										go to MR255

- Notes:
1. RFU bits must be set to 0 during MRW.
 2. RFU bits must be read as 0 during MRR.
 3. For READs to a write-only or RFU register, DQS will be toggled and undefined data is returned.
 4. RFU mode registers must not be written.
 5. WRITEs to read-only registers must have no impact on the functionality of the device.

Table 10: MR0 Device Information (MA[7:0] = 00h)

OP7	OP6	OP5	OP4	OP3	OP2	OP1	OP0
RFU			RZQI		DNVI	DI	DAI

Table 11: MR0 Op-Code Bit Definitions

Notes 1–4 apply to all parameters and conditions

Register Information	Tag	Type	OP	Definition
Device auto initialization status	DAI	Read-only	OP0	0b: DAI complete
				1b: DAI in progress
Device information	DI	Read-only	OP1	0b
				1b: NVM
Data not valid information	DNVI	Read-only	OP2	0b: DNVI not supported
Built-in self test for RZQ information	RZQI	Read-only	OP[4:3]	00b: RZQ self test not supported
				01b: ZQ pin might be connected to V_{DDCA} or left floating
				10b: ZQ pin might be shorted to ground
				11b: ZQ pin self test complete; no error condition detected

- Notes:
1. If RZQI is supported, it will be set upon completion of the MRW ZQ initialization calibration.
 2. If ZQ is connected to V_{DDCA} to set default calibration, OP[4:3] must be set to 01. If ZQ is not connected to V_{DDCA} , either OP[4:3] = 01 or OP[4:3] = 10 could indicate a ZQ-pin assembly error. It is recommended that the assembly error be corrected.
 3. In the case of a possible assembly error (either OP[4:3] = 01 or OP[4:3] = 10, as defined above), the device will default to factory trim settings for R_{ON} and will ignore ZQ calibration commands. In either case, the system might not function as intended.
 4. If a ZQ self test returns a value of 11b, this indicates that the device has detected a resistor connection to the ZQ pin. Note that this result cannot be used to validate the ZQ resistor value, nor does it indicate that the ZQ resistor tolerance meets the specified limits (240 ohms $\pm 1\%$).

Table 12: MR1 Device Feature 1 (MA[7:0] = 01h)

OP7	OP6	OP5	OP4	OP3	OP2	OP1	OP0
nWR (for AP)			WC	BT	BL		

Table 13: MR1 Op-Code Bit Definitions

Feature	Type	OP	Definition	Notes
BL = burst length	Write-only	OP[2:0]	010b: BL4 (default)	
			011b: BL8	
			100b: BL16	
			All others: Reserved	
BT = burst type	Write-only	OP3	0b: Sequential (default)	
			1b: Interleaved	
WC = wrap control	Write-only	OP4	0b: Wrap (default)	
			1b: No wrap	
nWR = number of t _{WR} clock cycles	Write-only	OP[7:5]	001b: nWR = 3 (default)	1
			010b: nWR = 4	
			011b: nWR = 5	
			100b: nWR = 6	
			101b: nWR = 7	
			110b: nWR = 8	
			All others: Reserved	

Note: 1. The programmed value in nWR register is the number of clock cycles that determines when to start internal precharge operation for a WRITE burst with AP enabled. It is determined by RU (t_{WR}/t_{CK}).

Table 14: Burst Sequence by Burst Length (BL), Burst Type (BT), and Wrap Control (WC)

Notes 1–5 apply to all parameters and conditions

BL	BT	C3	C2	C1	C0	WC	Burst Cycle Number and Burst Address Sequence																	
							1	2	3	4	5	6	7	8	9	10	11	12	13	14	15	16		
4	Any	X	X	0b	0b	Wrap	0	1	2	3														
		X	X	1b	0b		2	3	0	1														
	Any	X	X	X	0b	No wrap	y	y+1	y+2	y+3														
8	Seq	X	0b	0b	0b	Wrap	0	1	2	3	4	5	6	7										
		X	0b	1b	0b		2	3	4	5	6	7	0	1										
		X	1b	0b	0b		4	5	6	7	0	1	2	3										
		X	1b	1b	0b		6	7	0	1	2	3	4	5										
	Int	X	0b	0b	0b		0	1	2	3	4	5	6	7										
		X	0b	1b	0b		2	3	0	1	6	7	4	5										
		X	1b	0b	0b		4	5	6	7	0	1	2	3										
		X	1b	1b	0b		6	7	4	5	2	3	0	1										
Any	X	X	X	0b	No wrap	Illegal (not supported)																		

Table 14: Burst Sequence by Burst Length (BL), Burst Type (BT), and Wrap Control (WC) (Continued)

Notes 1–5 apply to all parameters and conditions

BL	BT	C3	C2	C1	C0	WC	Burst Cycle Number and Burst Address Sequence															
							1	2	3	4	5	6	7	8	9	10	11	12	13	14	15	16
16	Seq	0b	0b	0b	0b	Wrap	0	1	2	3	4	5	6	7	8	9	A	B	C	D	E	F
		0b	0b	1b	0b		2	3	4	5	6	7	8	9	A	B	C	D	E	F	0	1
		0b	1b	0b	0b		4	5	6	7	8	9	A	B	C	D	E	F	0	1	2	3
		0b	1b	1b	0b		6	7	8	9	A	B	C	D	E	F	0	1	2	3	4	5
		1b	0b	0b	0b		8	9	A	B	C	D	E	F	0	1	2	3	4	5	6	7
		1b	0b	1b	0b		A	B	C	D	E	F	0	1	2	3	4	5	6	7	8	9
		1b	1b	0b	0b		C	D	E	F	0	1	2	3	4	5	6	7	8	9	A	B
		1b	1b	1b	0b		E	F	0	1	2	3	4	5	6	7	8	9	A	B	C	D
	Int	X	X	X	0b	Illegal (not supported)																
Any	X	X	X	0b	Illegal (not supported)																	
					No wrap																	

- Notes:
1. C0 input is not present on CA bus. It is implied zero.
 2. For BL = 4, the burst address represents C[1:0].
 3. For BL = 8, the burst address represents C[2:0].
 4. For BL = 16, the burst address represents C[3:0].
 5. For no-wrap, BL4, the burst must not cross the page boundary or the sub-page boundary. The variable y can start at any address with C0 equal to 0, but must not start at any address shown in the following table.

Table 15: No-Wrap Restrictions

Width	64Mb	128Mb/256Mb	512Mb/1Gb/2Gb	4Gb/8Gb
Cannot cross full-page boundary				
x16	FE, FF, 00, 01	1FE, 1FF, 000, 001	3FE, 3FF, 000, 001	7FE, 7FF, 000, 001
x32	7E, 7F, 00, 01	FE, FF, 00, 01	1FE, 1FF, 000, 001	3FE, 3FF, 000, 001
Cannot cross sub-page boundary				
x16	7E, 7F, 80, 81	0FE, 0FF, 100, 101	1FE, 1FF, 200, 201	3FE, 3FF, 400, 401
x32	None	None	None	None

Note: 1. No-wrap BL = 4 data orders shown are prohibited.

Table 16: MR2 Device Feature 2 (MA[7:0] = 02h)

OP7	OP6	OP5	OP4	OP3	OP2	OP1	OP0
RFU				RL and WL			

Table 17: MR2 Op-Code Bit Definitions

Feature	Type	OP	Definition
RL and WL	Write-only	OP[3:0]	0001b: RL3/WL1 (default)
			0010b: RL4/WL2
			0011b: RL5/WL2
			0100b: RL6/WL3
			0101b: RL7/WL4
			0110b: RL8/WL4
			All others: Reserved

Table 18: MR3 I/O Configuration 1 (MA[7:0] = 03h)

OP7	OP6	OP5	OP4	OP3	OP2	OP1	OP0
RFU				DS			

Table 19: MR3 Op-Code Bit Definitions

Feature	Type	OP	Definition
DS	Write-only	OP[3:0]	0000b: Reserved
			0001b: 34.3 ohm typical
			0010b: 40 ohm typical (default)
			0011b: 48 ohm typical
			0100b: 60 ohm typical
			0101b: Reserved
			0110b: 80 ohm typical
			0111b: 120 ohm typical
All others: Reserved			

Table 20: MR4 Device Temperature (MA[7:0] = 04h)

OP7	OP6	OP5	OP4	OP3	OP2	OP1	OP0
TUF	RFU				SDRAM refresh rate		

Table 21: MR4 Op-Code Bit Definitions

Notes 1–10 apply to all parameters and conditions

Feature	Type	OP	Definition
SDRAM refresh rate	Read-only	OP[2:0]	000b: SDRAM low temperature operating limit exceeded
			001b: $4 \times t_{REFI}$, $4 \times t_{REFIpb}$, $4 \times t_{REFW}$
			010b: $2 \times t_{REFI}$, $2 \times t_{REFIpb}$, $2 \times t_{REFW}$
			011b: $1 \times t_{REFI}$, $1 \times t_{REFIpb}$, $1 \times t_{REFW}$ ($\leq 85^\circ\text{C}$)
			100b: Reserved
			101b: $0.25 \times t_{REFI}$, $0.25 \times t_{REFIpb}$, $0.25 \times t_{REFW}$, do not derate SDRAM AC timing
			110b: $0.25 \times t_{REFI}$, $0.25 \times t_{REFIpb}$, $0.25 \times t_{REFW}$, derate SDRAM AC timing
			111b: SDRAM high temperature operating limit exceeded
Temperature update flag (TUF)	Read-only	OP7	0b: OP[2:0] value has not changed since last read of MR4
			1b: OP[2:0] value has changed since last read of MR4

- Notes:
1. A MODE REGISTER READ from MR4 will reset OP7 to 0.
 2. OP7 is reset to 0 at power-up.
 3. If OP2 = 1, the device temperature is greater than 85°C.
 4. OP7 is set to 1 if OP[2:0] has changed at any time since the last MR4 read.
 5. The device might not operate properly when OP[2:0] = 000b or 111b.
 6. For specified operating temperature range and maximum operating temperature, refer to the Operating Temperature Range table.
 7. LPDDR2 devices must be derated by adding 1.875ns to the following core timing parameters: t_{RCD} , t_{RC} , t_{RAS} , t_{RP} , and t_{RRD} . The t_{DQSCK} parameter must be derated as specified in AC Timing. Prevailing clock frequency specifications and related setup and hold timings remain unchanged.
 8. The recommended frequency for reading MR4 is provided in Temperature Sensor (page 66).
 9. While the AT grade product is guaranteed to operate from $T_{CASE} -40^\circ\text{C}$ to 105°C , the temperature sensor accuracy relative to this is not guaranteed. The temperature sensor embedded in the LPDDR2 device is not an accurate reflection of the DRAM T_{CASE} operating temperature. Sampling of the sensor has shown up to a $\pm 7^\circ\text{C}$ variance from actual T_{CASE} .
 10. The temp sensor is not working above 105°C , but datasheet functionality guaranteed for products raged up to 125°C (AUT).

Table 22: MR5 Basic Configuration 1 (MA[7:0] = 05h)

OP7	OP6	OP5	OP4	OP3	OP2	OP1	OP0
LPDDR2 Manufacturer ID							

Table 23: MR5 Op-Code Bit Definitions

Feature	Type	OP	Definition
Manufacturer ID	Read-only	OP[7:0]	0000 0011b: Micron
			All others: Reserved

Table 24: MR6 Basic Configuration 2 (MA[7:0] = 06h)

OP7	OP6	OP5	OP4	OP3	OP2	OP1	OP0
Revision ID1							

Note: 1. MR6 is vendor-specific.

Table 25: MR6 Op-Code Bit Definitions

Feature	Type	OP	Definition
Revision ID1	Read-only	OP[7:0]	0000 0000b: Version A

Table 26: MR7 Basic Configuration 3 (MA[7:0] = 07h)

OP7	OP6	OP5	OP4	OP3	OP2	OP1	OP0
Revision ID2							

Table 27: MR7 Op-Code Bit Definitions

Feature	Type	OP	Definition
Revision ID2	Read-only	OP[7:0]	0000 0000b: Version A

Note: 1. MR7 is vendor-specific.

Table 28: MR8 Basic Configuration 4 (MA[7:0] = 08h)

OP7	OP6	OP5	OP4	OP3	OP2	OP1	OP0
I/O width		Density				Type	

Table 29: MR8 Op-Code Bit Definitions

Feature	Type	OP	Definition
Type	Read-only	OP[1:0]	00b
			01b
			10b: NVM
			11b: Reserved

Table 29: MR8 Op-Code Bit Definitions (Continued)

Feature	Type	OP	Definition
Density	Read-only	OP[5:2]	0000b: 64Mb
			0001b: 128Mb
			0010b: 256Mb
			0011b: 512Mb
			0100b: 1Gb
			0101b: 2Gb
			0110b: 4Gb
			0111b: 8Gb
			1000b: 16Gb
			1001b: 32Gb
			All others: Reserved
I/O width	Read-only	OP[7:6]	00b: x32
			01b: x16
			10b: x8
			11b: not used

Table 30: MR9 Test Mode (MA[7:0] = 09h)

OP7	OP6	OP5	OP4	OP3	OP2	OP1	OP0
Vendor-specific test mode							

Table 31: MR10 Calibration (MA[7:0] = 0Ah)

	OP7	OP6	OP5	OP4	OP3	OP2	OP1	OP0
S4	Calibration code							

Table 32: MR10 Op-Code Bit Definitions

Notes 1–4 apply to all parameters and conditions

Feature	Type	OP	Definition
Calibration code	Write-only	OP[7:0]	0xFF: Calibration command after initialization
			0xAB: Long calibration
			0x56: Short calibration
			0xC3: ZQRESET
			All others: Reserved

- Notes:
1. Host processor must not write MR10 with reserved values.
 2. The device ignores calibration commands when a reserved value is written into MR10.
 3. See AC timing table for the calibration latency.

- If ZQ is connected to V_{SSCA} through R_{ZQ} , either the ZQ calibration function (see MRW ZQ Calibration Commands (page 71)) or default calibration (through the ZQRESET command) is supported. If ZQ is connected to V_{DDCA} , the device operates with default calibration, and ZQ calibration commands are ignored. In both cases, the ZQ connection must not change after power is supplied to the device.

Table 33: MR[11:15] Reserved (MA[7:0] = 0Bh–0Fh)

OP7	OP6	OP5	OP4	OP3	OP2	OP1	OP0
Reserved							

Table 34: MR16 PASR Bank Mask (MA[7:0] = 010h)

OP7	OP6	OP5	OP4	OP3	OP2	OP1	OP0
Bank mask (4-bank)							

Table 35: MR16 Op-Code Bit Definitions

Feature	Type	OP	Definition
Bank[7:0] mask	Write-only	OP[7:0]	0b: refresh enable to the bank = unmasked (default)
			1b: refresh blocked = masked

Note: 1. For 4-bank devices, only OP[3:0] are used.

Table 36: MR17 PASR Segment Mask (MA[7:0] = 011h)

OP7	OP6	OP5	OP4	OP3	OP2	OP1	OP0
Segment mask							

Note: 1. This table applies for 1Gb to 8Gb devices only.

Table 37: MR17 PASR Segment Mask Definitions

Feature	Type	OP	Definition
Segment[7:0] mask	Write-only	OP[7:0]	0b: refresh enable to the segment: = unmasked (default)
			1b: refresh blocked: = masked

Table 38: MR17 PASR Row Address Ranges in Masked Segments

Segment	OP	Segment Mask	1Gb	2Gb, 4Gb	8Gb
			R[12:10]	R[13:11]	R[14:12]
0	0	XXXXXXXX1	000b		
1	1	XXXXXX1X	001b		
2	2	XXXXX1XX	010b		
3	3	XXXX1XXX	011b		

Table 38: MR17 PASR Row Address Ranges in Masked Segments (Continued)

Segment	OP	Segment Mask	1Gb	2Gb, 4Gb	8Gb
			R[12:10]	R[13:11]	R[14:12]
4	4	XXX1XXXX	100b		
5	5	XX1XXXXX	101b		
6	6	X1XXXXXX	110b		
7	7	1XXXXXXX	111b		

Note: 1. X is "Don't Care" for the designated segment.

Table 39: Reserved Mode Registers

Mode Register	MA	Address	Restriction	OP7	OP6	OP5	OP4	OP3	OP2	OP1	OP0
MR[18:19]	MA[7:0]	12h–13h	RFU	Reserved							
MR[20:31]		14h–1Fh	NVM ¹								
MR[33:39]		21h–27h	DNU ¹								
MR[41:47]		29h–2Fh									
MR[48:62]		30h–3Eh	RFU								
MR[64:126]		40h–7Eh	RFU								
MR127		7Fh	DNU								
MR[128:190]		80h–BEh	RVU ¹								
MR191		BFh	DNU								
MR[192:254]		C0h–FEh	RVU								
MR255		FFh	DNU								

Note: 1. NVM = nonvolatile memory use only; DNU = Do not use; RVU = Reserved for vendor use.

Table 40: MR63 RESET (MA[7:0] = 3Fh) – MRW Only

OP7	OP6	OP5	OP4	OP3	OP2	OP1	OP0
X							

Note: 1. For additional information on MRW RESET see MODE REGISTER WRITE Command (page 70).

ACTIVATE Command

The ACTIVATE command is issued by holding CS# LOW, CA0 LOW, and CA1 HIGH at the rising edge of the clock. The bank addresses BA[1:0] are used to select the desired bank. Row addresses are used to determine which row to activate in the selected bank. The ACTIVATE command must be applied before any READ or WRITE operation can be executed. The device can accept a READ or WRITE command at t_{RCD} after the ACTIVATE command is issued. After a bank has been activated, it must be precharged before another ACTIVATE command can be applied to the same bank. The bank active and precharge times are defined as t_{RAS} and t_{RP} , respectively. The minimum time interval between successive ACTIVATE commands to the same bank is determined by the RAS cycle time of the device (t_{RC}). The minimum time interval between ACTIVATE commands to different banks is t_{RRD} .

Figure 11: ACTIVATE Command

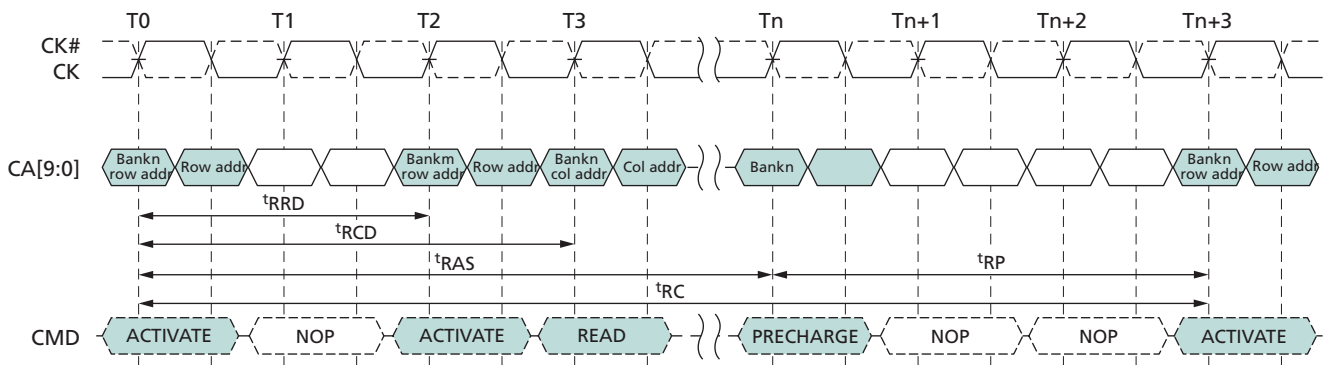

- Notes:
1. $t_{RCD} = 3$, $t_{RP} = 3$, $t_{RRD} = 2$.
 2. A PRECHARGE ALL command uses t_{RPab} timing, and a single-bank PRECHARGE command uses t_{RPpb} timing. In this figure, t_{RP} is used to denote either an all-bank PRECHARGE or a single-bank PRECHARGE.

Read and Write Access Modes

After a bank is activated, a READ or WRITE command can be issued with CS# LOW, CA0 HIGH, and CA1 LOW at the rising edge of the clock. CA2 must also be defined at this time to determine whether the access cycle is a READ operation (CA2 HIGH) or a WRITE operation (CA2 LOW). A single READ or WRITE cycles command initiates a burst READ or burst WRITE operation on successive clock cycles.

A new burst access must not interrupt the previous 4-bit burst operation when BL = 4. When BL = 8 or BL = 16, READs can be interrupted by READs and WRITEs can be interrupted by WRITEs, provided that the interrupt occurs on a 4-bit boundary and that t_{CCD} is met.

Burst READ Command

The burst READ command is initiated with CS# LOW, CA0 HIGH, CA1 LOW, and CA2 HIGH at the rising edge of the clock. The command address bus inputs, CA5r–CA6r and CA1f–CA9f, determine the starting column address for the burst. The read latency (RL) is defined from the rising edge of the clock on which the READ command is issued to

the rising edge of the clock from which the t_{DQSK} delay is measured. The first valid data is available $RL \times t_{CK} + t_{DQSK} + t_{DQSQ}$ after the rising edge of the clock when the READ command is issued. The data strobe output is driven LOW t_{RPRE} before the first valid rising strobe edge. The first bit of the burst is synchronized with the first rising edge of the data strobe. Each subsequent data-out appears on each DQ pin, edge-aligned with the data strobe. The RL is programmed in the mode registers.

Pin input timings for the data strobe are measured relative to the crosspoint of DQS and its complement, DQS#.

Figure 12: READ Output Timing – t_{DQSK} (MAX)

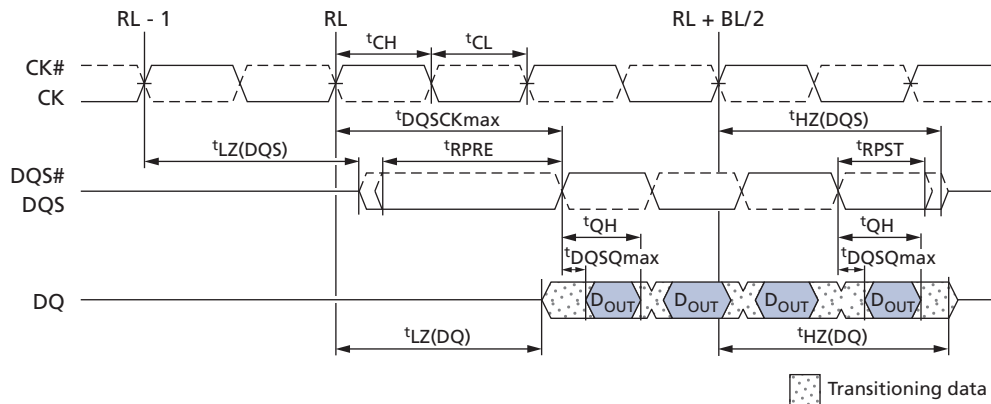

- Notes:
1. t_{DQSK} can span multiple clock periods.
 2. An effective burst length of 4 is shown.

Figure 13: READ Output Timing – t_{DQSK} (MIN)

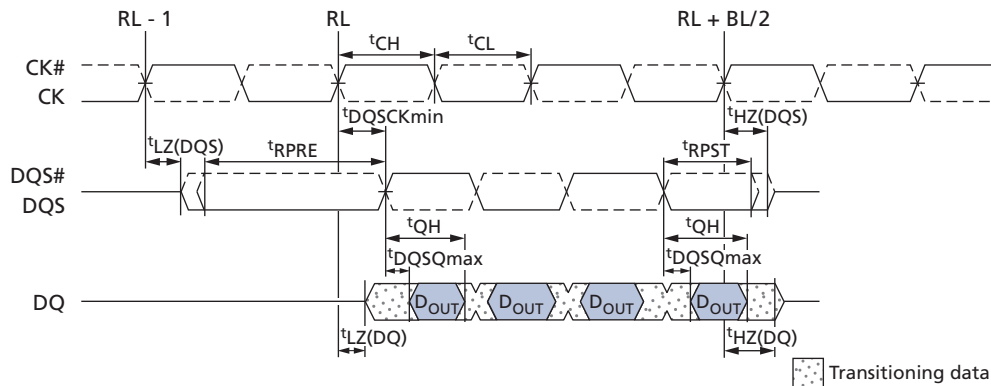

- Note:
1. An effective burst length of 4 is shown.

Figure 14: Burst READ – RL = 5, BL = 4, $t_{DQSCK} > t_{CK}$

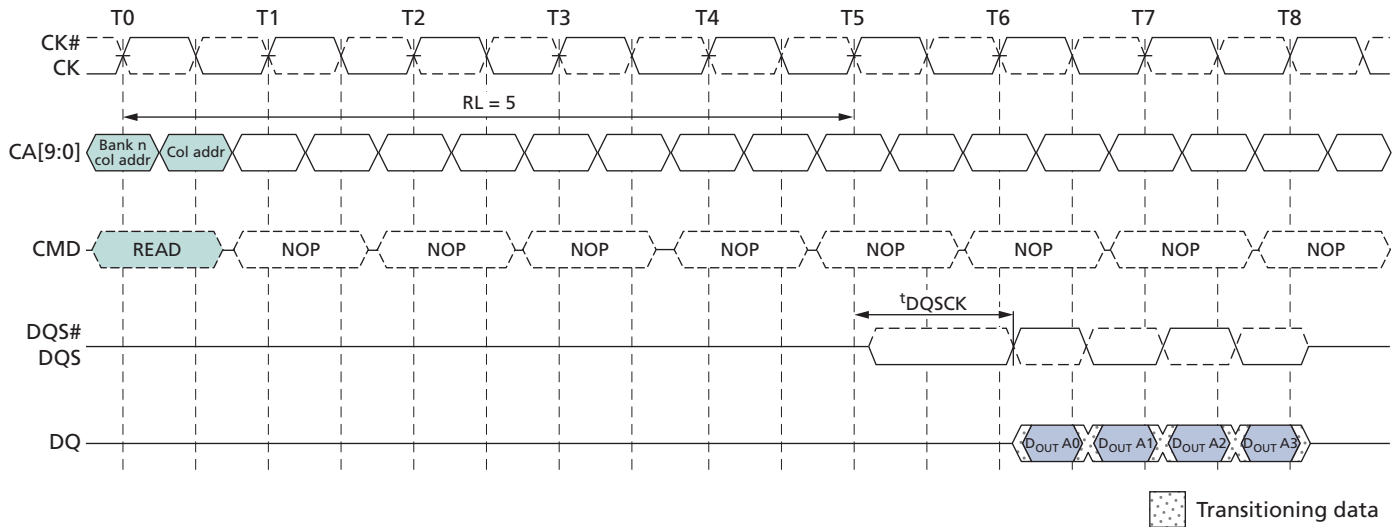

Figure 15: Burst READ – RL = 3, BL = 8, $t_{DQSCK} < t_{CK}$

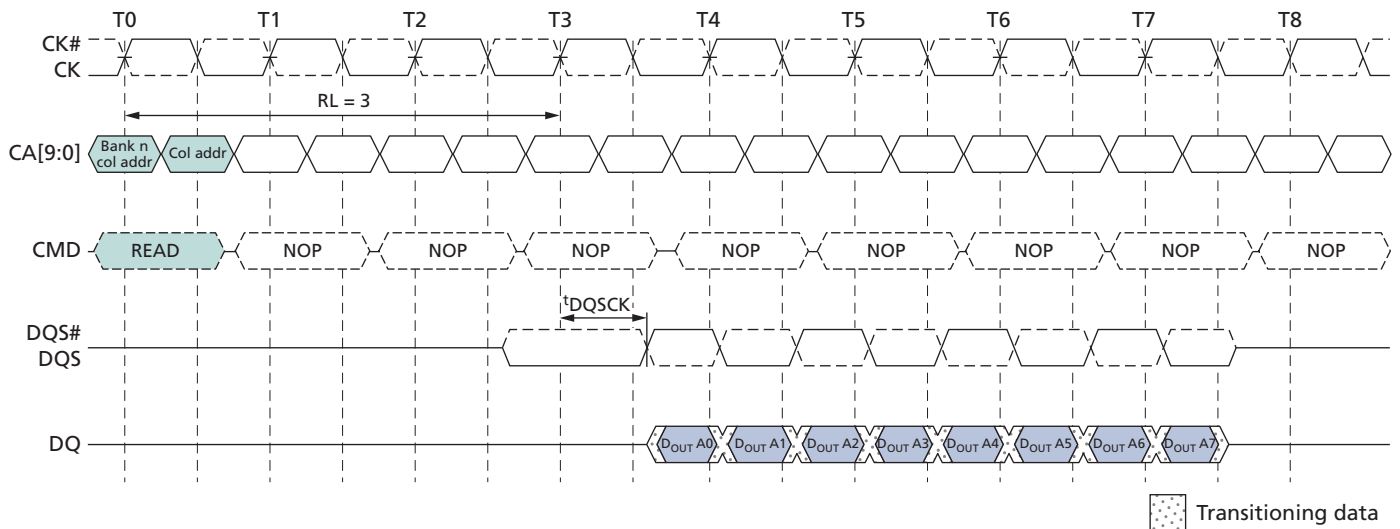
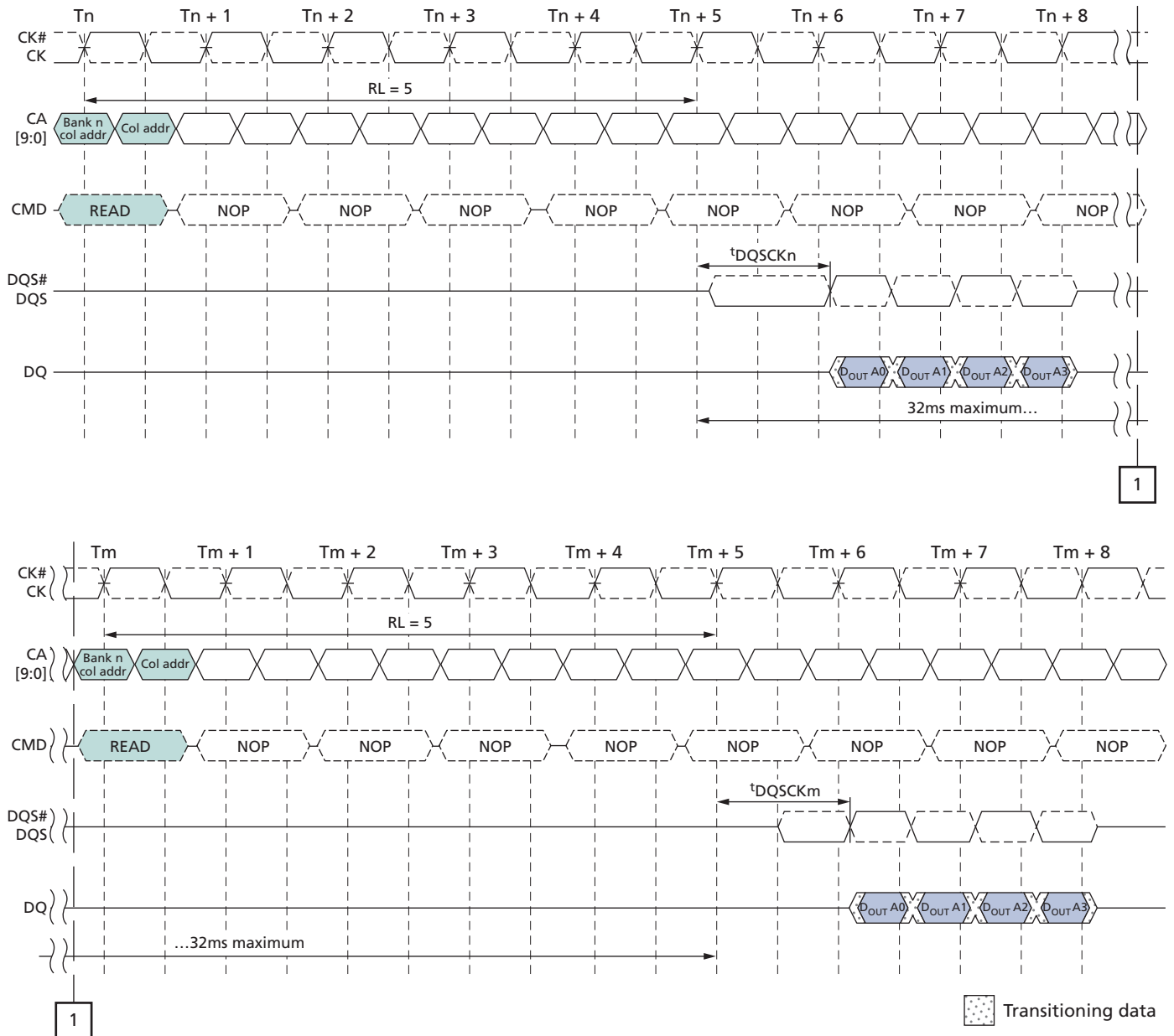
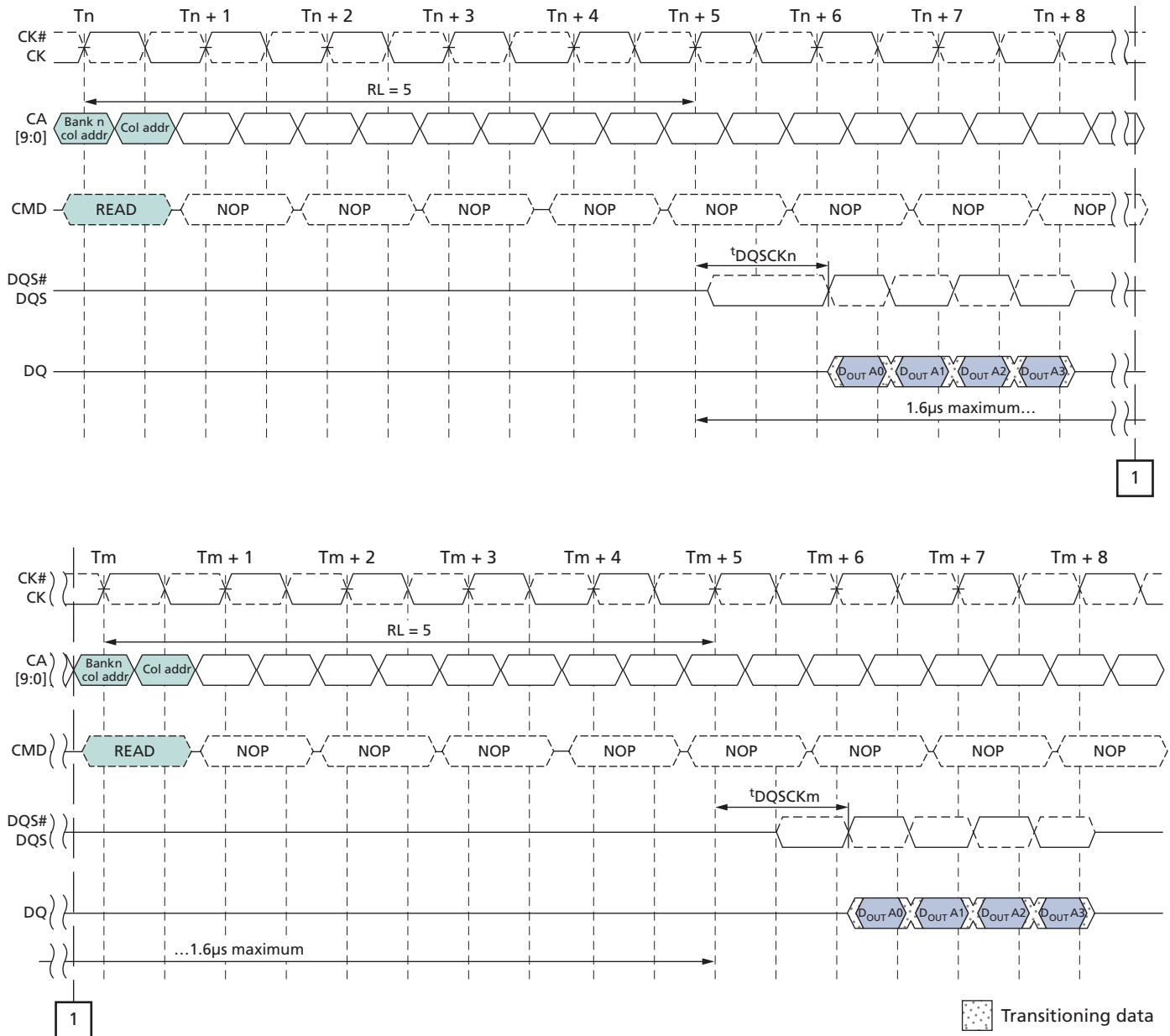

Figure 16: t_{DQSKDL} Timing



- Notes:
1. $t_{DQSKDL} = (t_{DQSKn} - t_{DQSKm})$.
 2. $t_{DQSKDL} (MAX)$ is defined as the maximum of ABS ($t_{DQSKn} - t_{DQSKm}$) for any (t_{DQSKn} , t_{DQSKm}) pair within any 32ms rolling window.

Figure 17: t_{DQSKDM} Timing



- Notes:
1. $t_{DQSKDM} = (t_{DQSKn} - t_{DQSKm})$.
 2. $t_{DQSKDM} (MAX)$ is defined as the maximum of ABS ($t_{DQSKn} - t_{DQSKm}$) for any (t_{DQSKn} , t_{DQSKm}) pair within any 1.6µs rolling window.

Figure 18: t_{DQCKDS} Timing

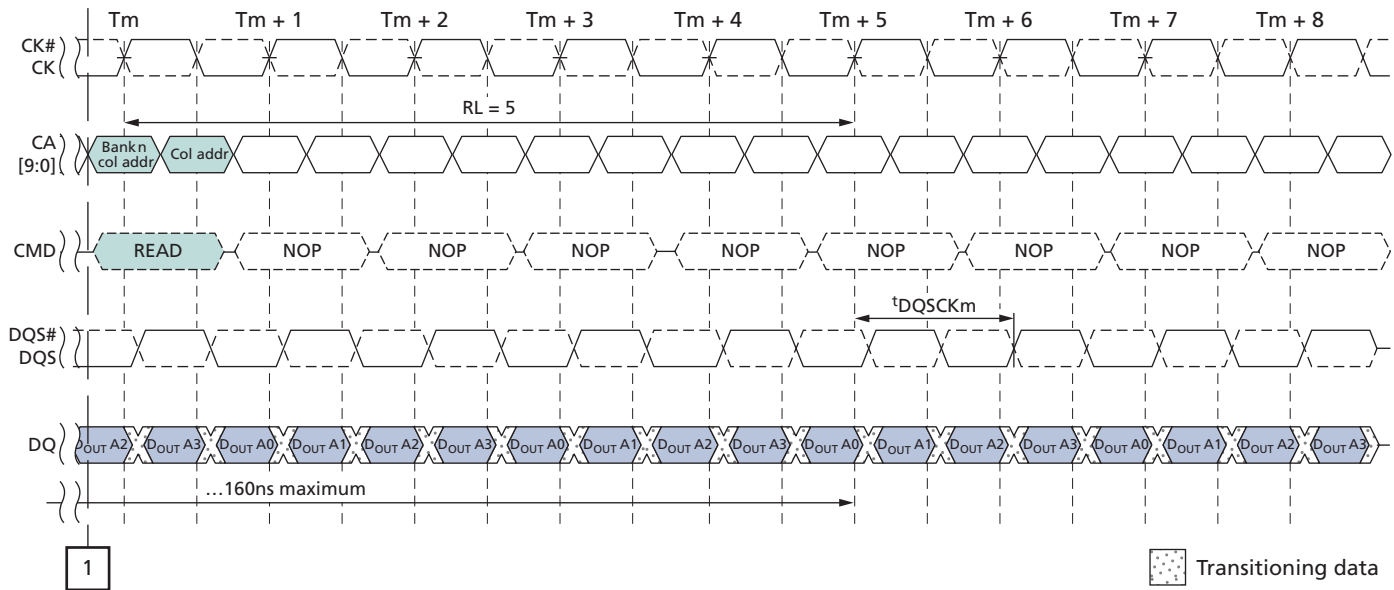
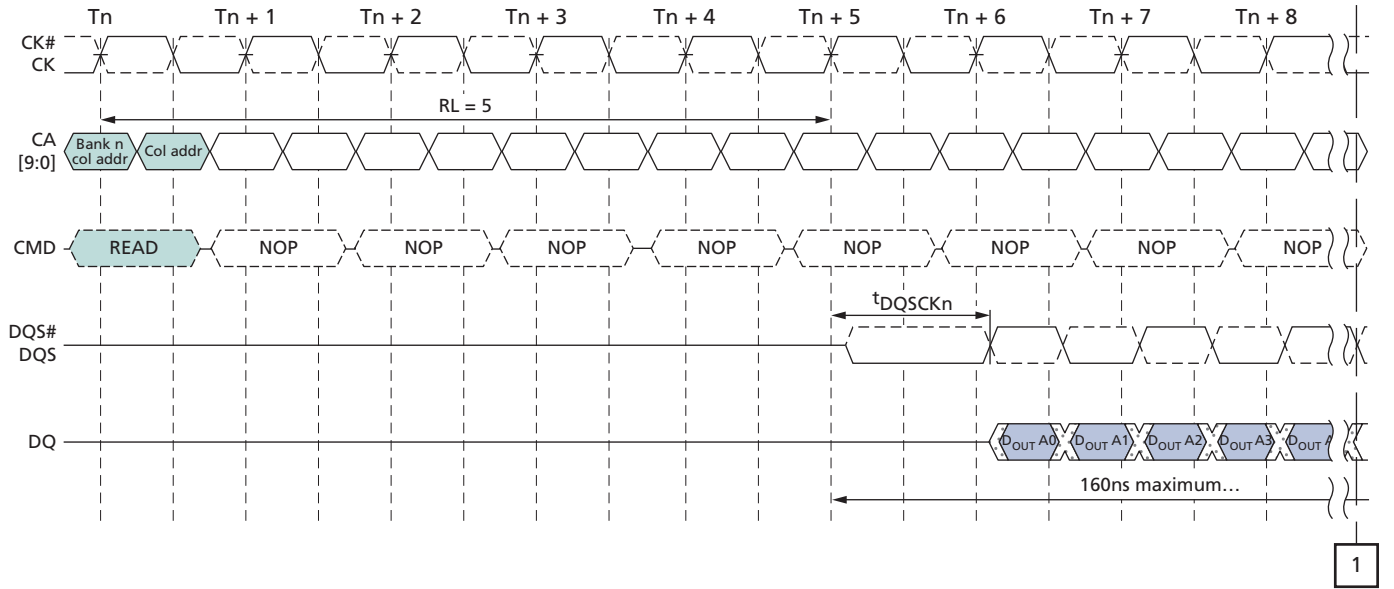

- Notes:
1. $t_{DQCKDS} = (t_{DQCKn} - t_{DQCKm})$.
 2. $t_{DQCKDS} (MAX)$ is defined as the maximum of ABS ($t_{DQCKn} - t_{DQCKm}$) for any (t_{DQCKn} , t_{DQCKm}) pair for READs within a consecutive burst, within any 160ns rolling window.

Figure 19: Burst READ Followed by Burst WRITE – RL = 3, WL = 1, BL = 4

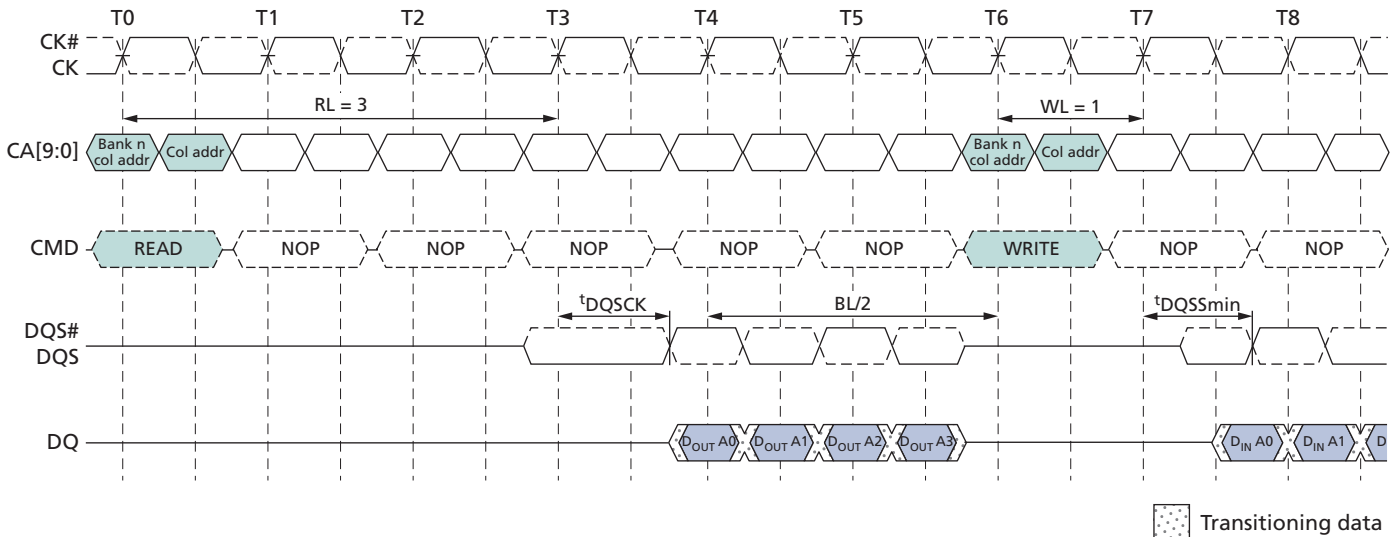

The minimum time from the burst READ command to the burst WRITE command is defined by the read latency (RL) and the burst length (BL). Minimum READ-to-WRITE latency is $RL + RU(t_{DQSCK}(\text{MAX})/t_{CK}) + BL/2 + 1 - WL$ clock cycles. Note that if a READ burst is truncated with a burst TERMINATE (BST) command, the effective burst length of the truncated READ burst should be used for BL when calculating the minimum READ-to-WRITE delay.

Figure 20: Seamless Burst READ – RL = 3, BL = 4, t_{CCD} = 2

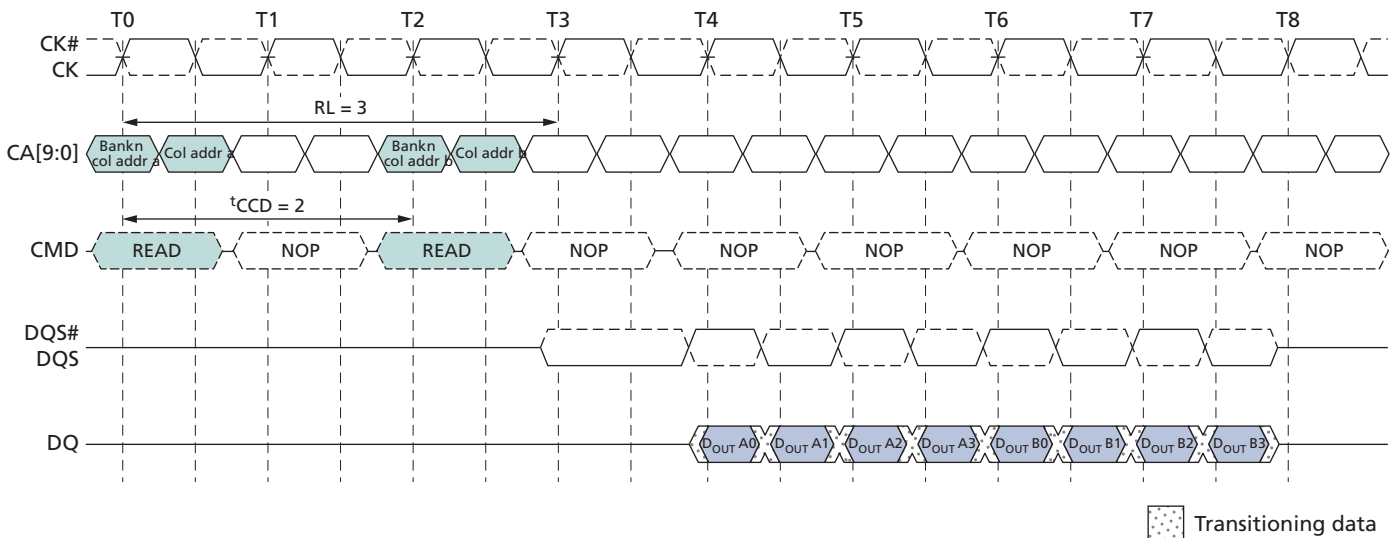

A seamless burst READ operation is supported by enabling a READ command at every other clock cycle for BL = 4 operation, every fourth clock cycle for BL = 8 operation, and every eighth clock cycle for BL = 16 operation. This operation is supported as long as the banks are activated, whether the accesses read the same or different banks.

READs Interrupted by a READ

A burst READ can be interrupted by another READ with a 4-bit burst boundary, provided that t_{CCD} is met.

Figure 21: READ Burst Interrupt Example – RL = 3, BL = 8, $t_{CCD} = 2$

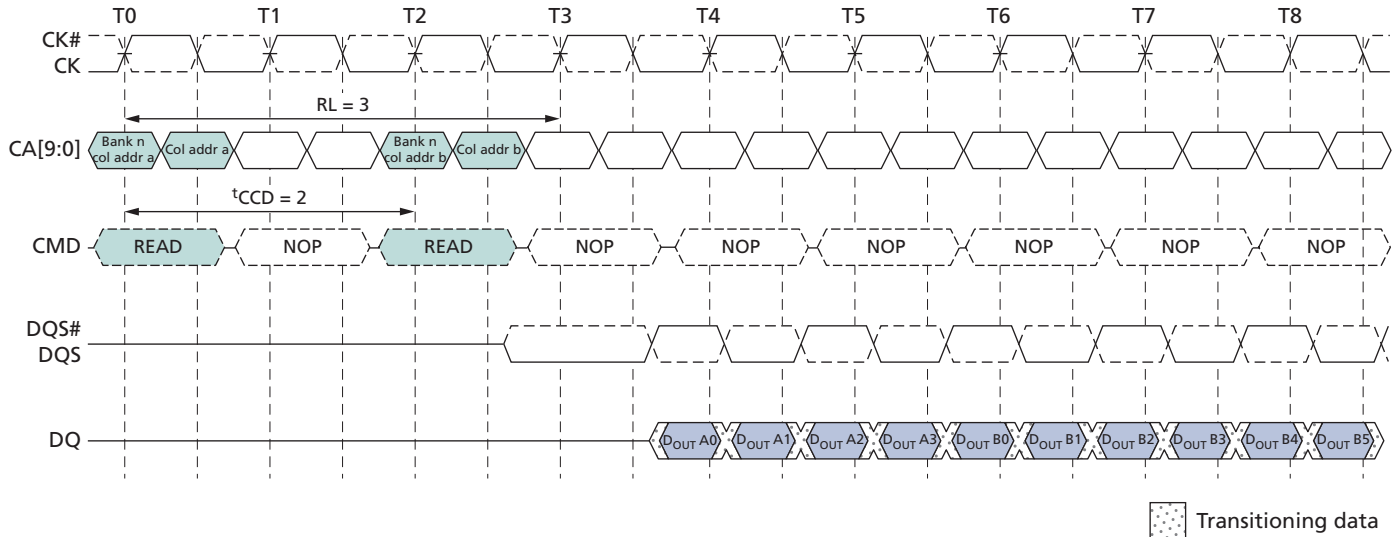

Note: 1. READs can only be interrupted by other READs or the BST command.

Burst WRITE Command

The burst WRITE command is initiated with CS# LOW, CA0 HIGH, CA1 LOW, and CA2 LOW at the rising edge of the clock. The command address bus inputs, CA5r–CA6r and CA1f–CA9f, determine the starting column address for the burst. Write latency (WL) is defined from the rising edge of the clock on which the WRITE command is issued to the rising edge of the clock from which the t_{DQSS} delay is measured. The first valid data must be driven $WL \times t_{CK} + t_{DQSS}$ from the rising edge of the clock from which the WRITE command is issued. The data strobe signal (DQS) must be driven LOW t_{WPRE} prior to data input. The burst cycle data bits must be applied to the DQ pins t_{DS} prior to the associated edge of the DQS and held valid until t_{DH} after that edge. Burst data is sampled on successive edges of the DQS until the 4-, 8-, or 16-bit burst length is completed. After a burst WRITE operation, t_{WR} must be satisfied before a PRECHARGE command to the same bank can be issued.

Pin input timings are measured relative to the crosspoint of DQS and its complement, DQS#.

Figure 22: Data Input (WRITE) Timing

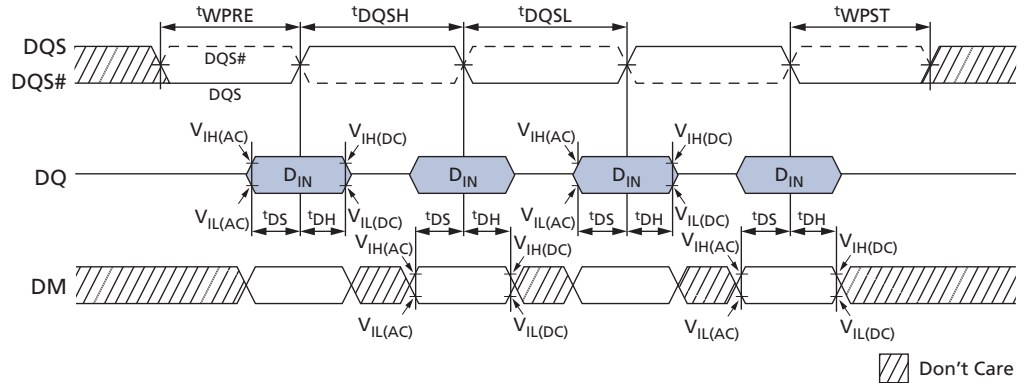

Figure 23: Burst WRITE – WL = 1, BL = 4

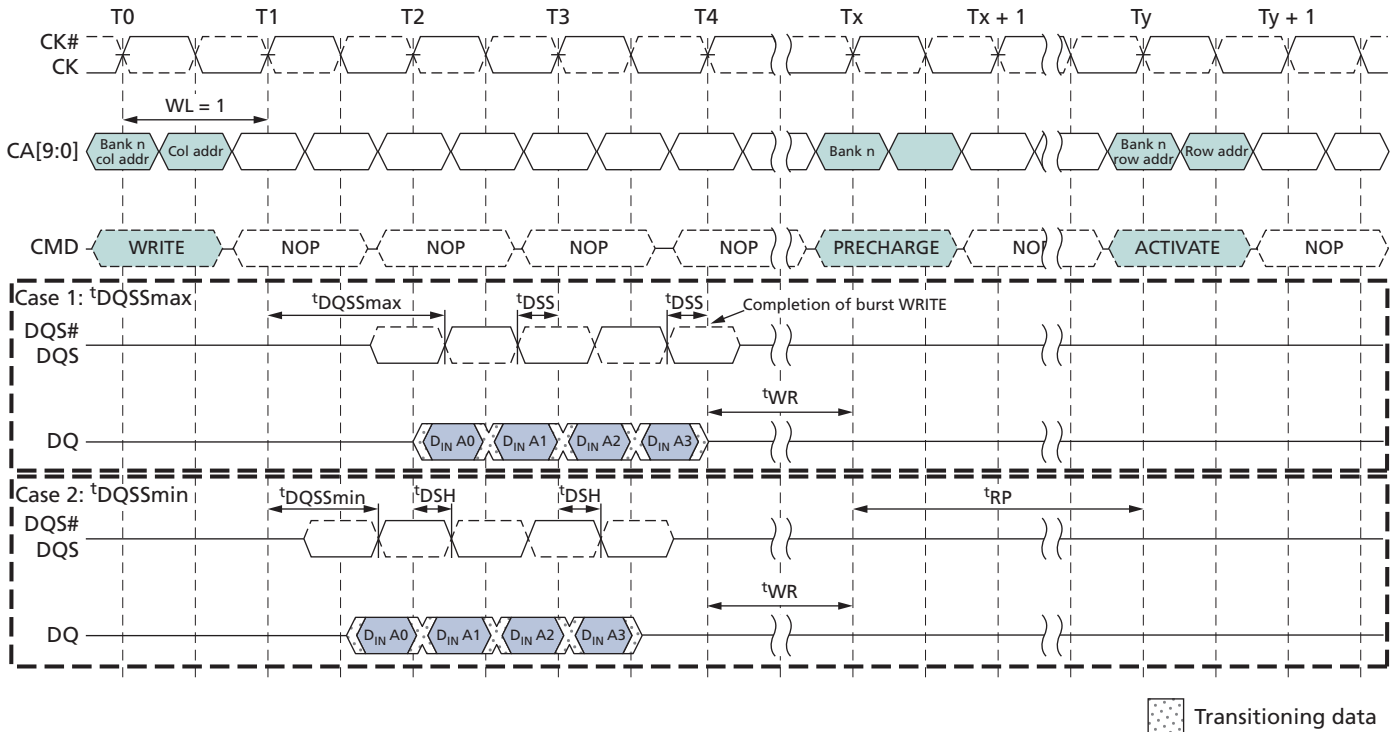
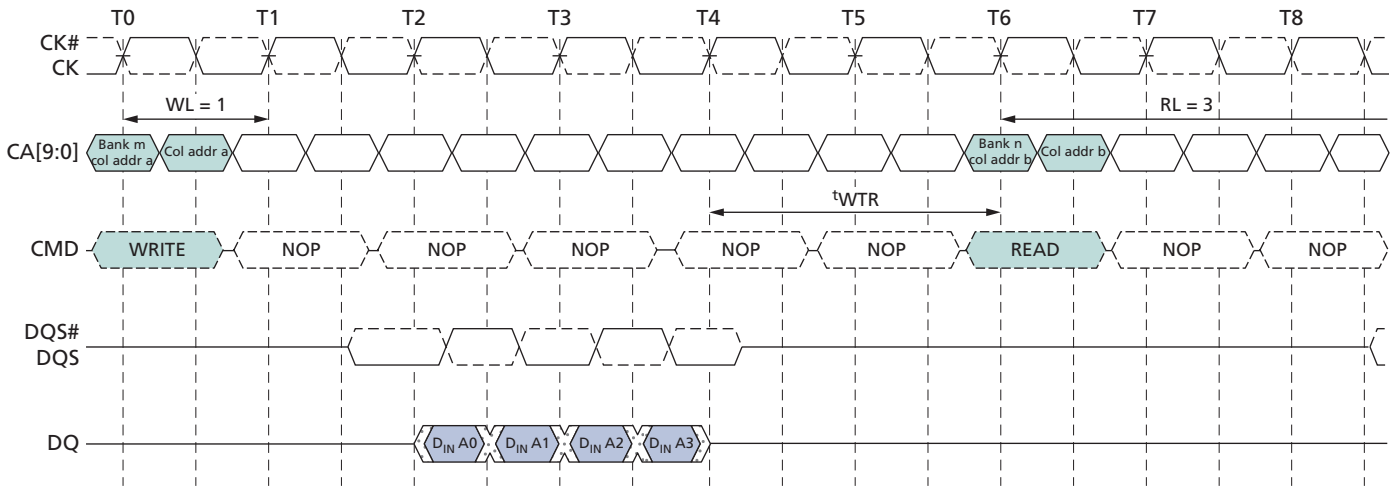

Figure 24: Burst WRITE Followed by Burst READ – RL = 3, WL = 1, BL = 4



Transitioning data

- Notes:
1. The minimum number of clock cycles from the burst WRITE command to the burst READ command for any bank is $[WL + 1 + BL/2 + RU(t_{WTR}/t_{CK})]$.
 2. t_{WTR} starts at the rising edge of the clock after the last valid input data.
 3. If a WRITE burst is truncated with a BST command, the effective burst length of the truncated WRITE burst should be used as BL to calculate the minimum WRITE-to-READ delay.

Figure 25: Seamless Burst WRITE – WL = 1, BL = 4, $t_{CCD} = 2$

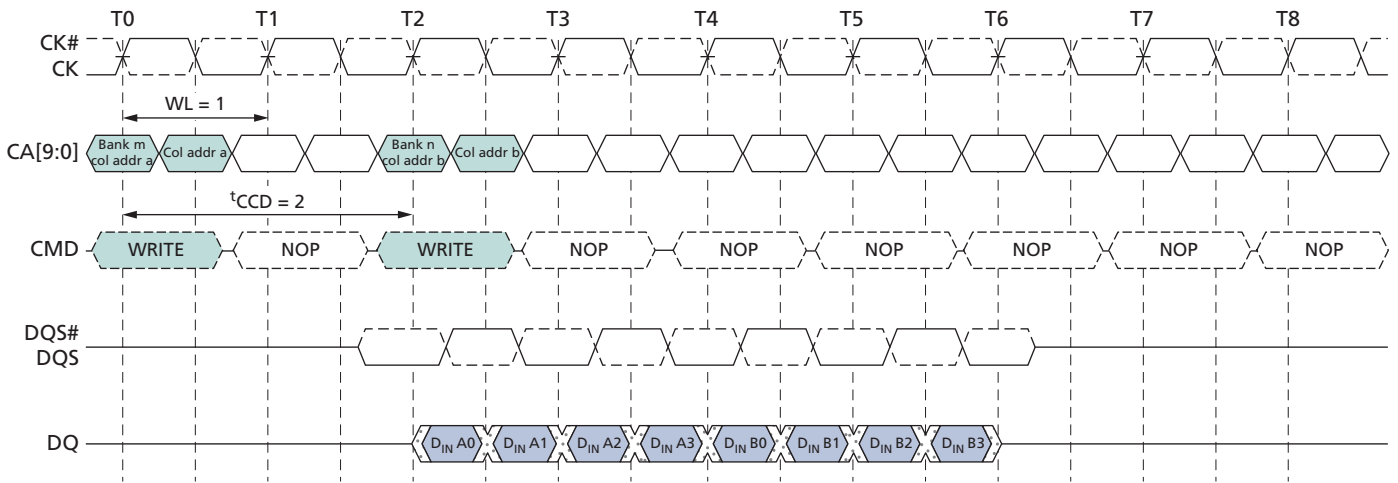

Transitioning data

- Note:
1. The seamless burst WRITE operation is supported by enabling a WRITE command every other clock for BL = 4 operation, every four clocks for BL = 8 operation, or every eight clocks for BL = 16 operation. This operation is supported for any activated bank.

WRITES Interrupted by a WRITE

A burst WRITE can only be interrupted by another WRITE with a 4-bit burst boundary, provided that t_{CCD} (MIN) is met.

A WRITE burst interrupt can occur on even clock cycles after the initial WRITE command, provided that t_{CCD} (MIN) is met.

Figure 26: WRITE Burst Interrupt Timing – WL = 1, BL = 8, $t_{CCD} = 2$

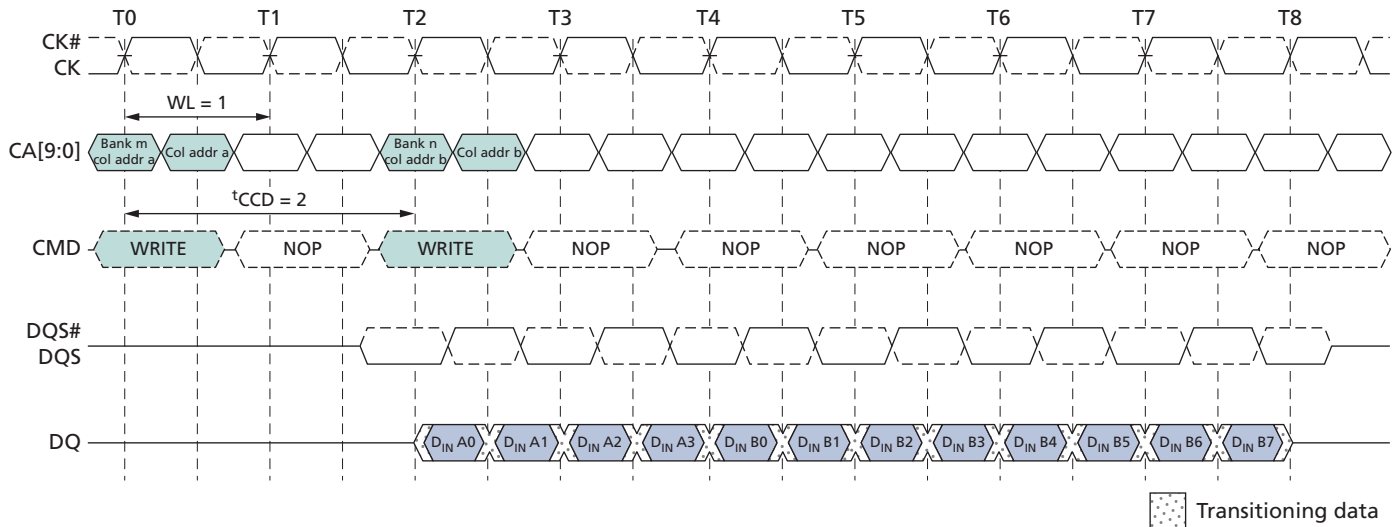

- Notes:
1. WRITES can only be interrupted by other WRITES or the BST command.
 2. The effective burst length of the first WRITE equals two times the number of clock cycles between the first WRITE and the interrupting WRITE.

BURST TERMINATE Command

The BURST TERMINATE (BST) command is initiated with CS# LOW, CA0 HIGH, CA1 HIGH, CA2 LOW, and CA3 LOW at the rising edge of the clock. A BST command can only be issued to terminate an active READ or WRITE burst. Therefore, a BST command can only be issued up to and including $BL/2 - 1$ clock cycles after a READ or WRITE command. The effective burst length of a READ or WRITE command truncated by a BST command is as follows:

- Effective burst length = $2 \times$ (number of clock cycles from the READ or WRITE command to the BST command).
- If a READ or WRITE burst is truncated with a BST command, the effective burst length of the truncated burst should be used for BL when calculating the minimum READ-to-WRITE or WRITE-to-READ delay.
- The BST command only affects the most recent READ or WRITE command. The BST command truncates an ongoing READ burst $RL \times t_{CK} + t_{DQSCK} + t_{DQSQ}$ after the rising edge of the clock where the BST command is issued. The BST command truncates an ongoing WRITE burst $WL \times t_{CK} + t_{DQSS}$ after the rising edge of the clock where the BST command is issued.

- The 4-bit prefetch architecture enables BST command assertion on even clock cycles following a WRITE or READ command. The effective burst length of a READ or WRITE command truncated by a BST command is thus an integer multiple of four.

Figure 27: Burst WRITE Truncated by BST – WL = 1, BL = 16

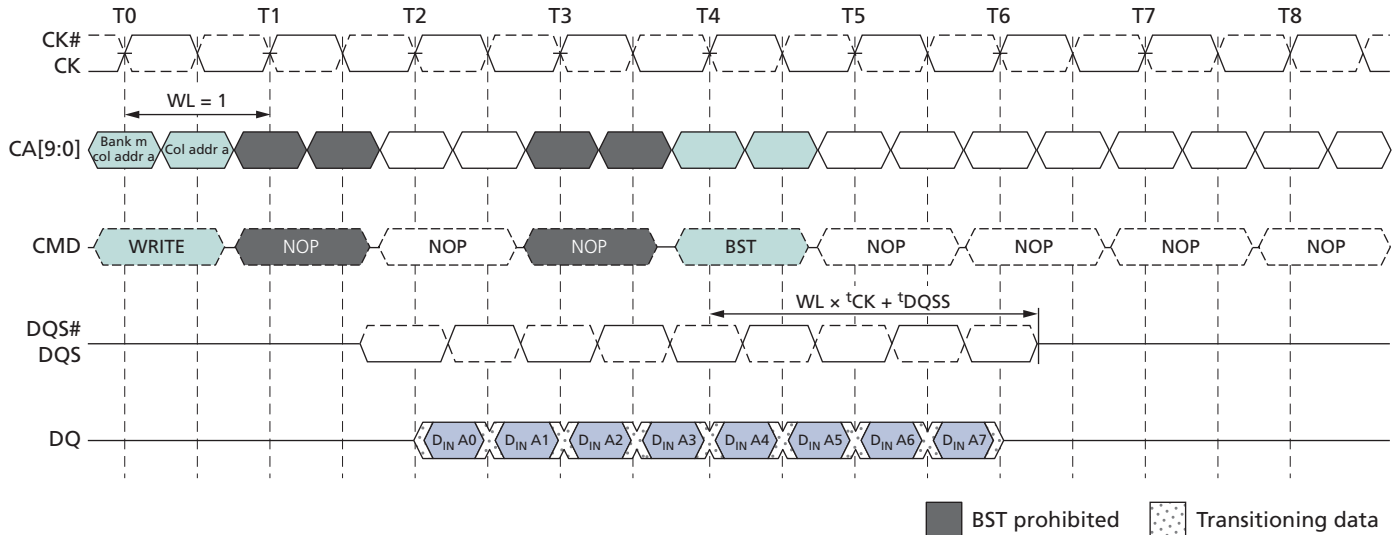

- Notes:
- The BST command truncates an ongoing WRITE burst $WL \times t_{CK} + t_{DQSS}$ after the rising edge of the clock where the BST command is issued.
 - BST can only be issued an even number of clock cycles after the WRITE command.
 - Additional BST commands are not supported after T4 and must not be issued until after the next READ or WRITE command.

Figure 28: Burst READ Truncated by BST – RL = 3, BL = 16

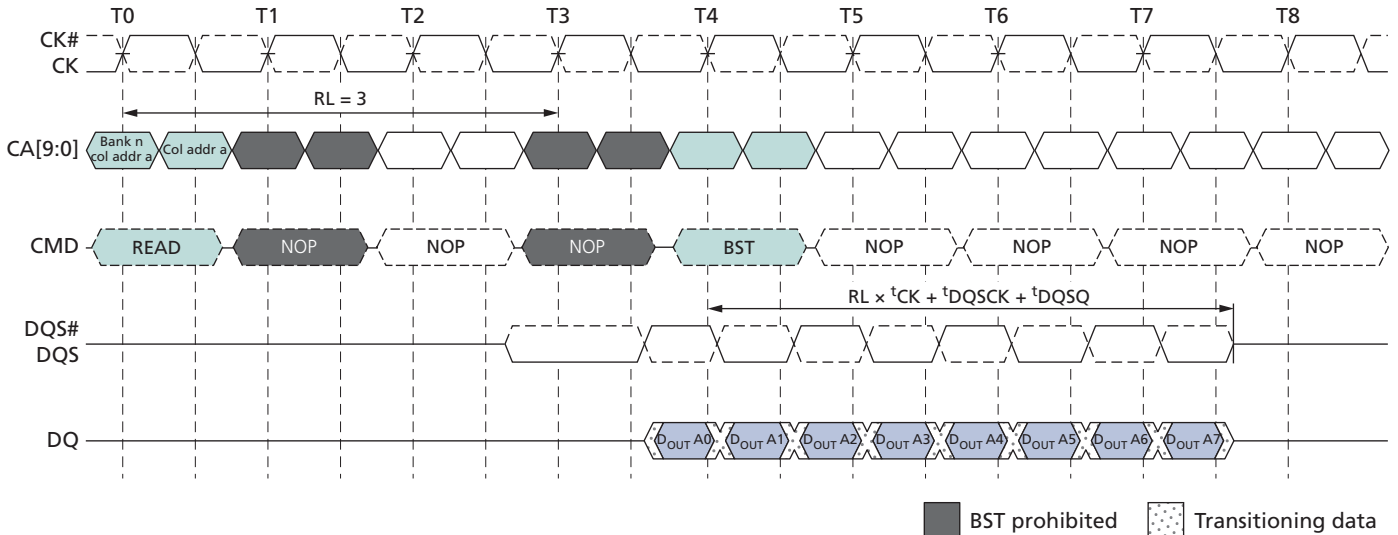

- Notes:
1. The BST command truncates an ongoing READ burst ($RL \times t_{CK} + t_{DQSK} + t_{DQSQ}$) after the rising edge of the clock where the BST command is issued.
 2. BST can only be issued an even number of clock cycles after the READ command.
 3. Additional BST commands are not supported after T4 and must not be issued until after the next READ or WRITE command.

Write Data Mask

On LPDDR2 devices, one write data mask (DM) pin for each data byte (DQ) is supported, consistent with the implementation on LPDDR SDRAM. Each DM can mask its respective DQ for any given cycle of the burst. Data mask timings match data bit timing, but are inputs only. Internal data mask loading is identical to data bit loading to ensure matched system timing.

Figure 29: Data Mask Timing

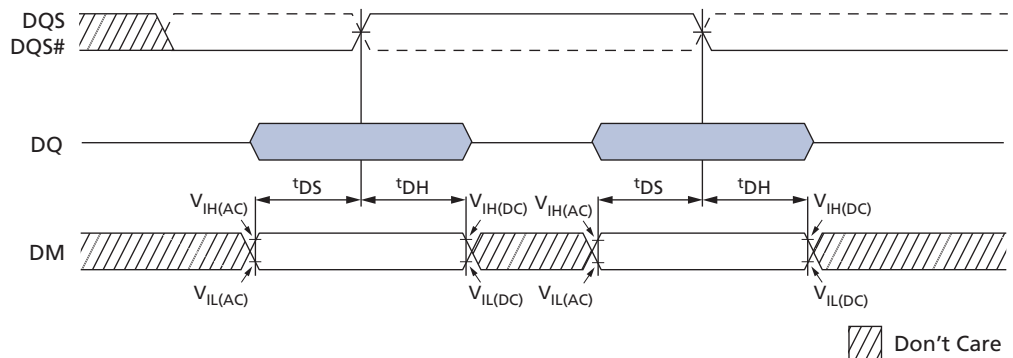
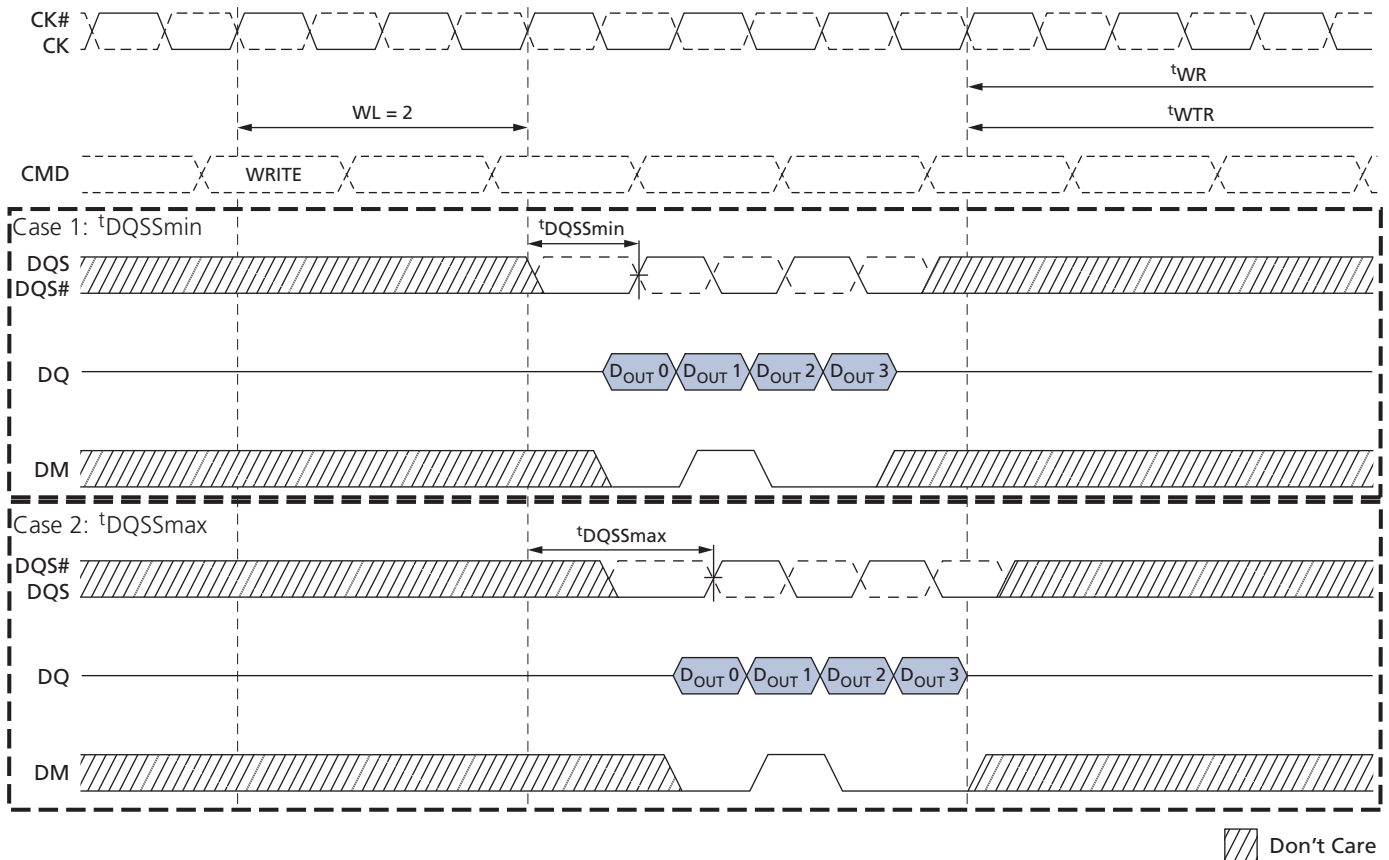

Figure 30: Write Data Mask – Second Data Bit Masked



Note: 1. For the data mask function, $WL = 2$, $BL = 4$ is shown; the second data bit is masked.

PRECHARGE Command

The PRECHARGE command is used to precharge or close a bank that has been activated. The PRECHARGE command is initiated with CS# LOW, CA0 HIGH, CA1 HIGH, CA2 LOW, and CA3 HIGH at the rising edge of the clock. The PRECHARGE command can be used to precharge each bank independently or all banks simultaneously. For 4-bank devices, the AB flag and bank address bits BA0 and BA1 are used to determine which bank(s) to precharge. The precharged bank(s) will be available for subsequent row access t_{RPab} after an all bank PRECHARGE command is issued, or t_{RPpb} after a single-bank PRECHARGE command is issued.

For 4-bank devices, t_{RPab} is equal to t_{RPpb} .

ACTIVATE to PRECHARGE timing is shown in ACTIVATE Command.

Table 41: Bank Selection for PRECHARGE by Address Bits

AB (CA4r)	BA2 (CA9r)	BA1 (CA8r)	BA0 (CA7r)	Precharged Bank(s) 4-Bank Device
0	0	0	0	Bank 0 only

Table 41: Bank Selection for PRECHARGE by Address Bits (Continued)

AB (CA4r)	BA2 (CA9r)	BA1 (CA8r)	BA0 (CA7r)	Precharged Bank(s) 4-Bank Device
0	0	0	1	Bank 1 only
0	0	1	0	Bank 2 only
0	0	1	1	Bank 3 only
0	1	0	0	Bank 0 only
0	1	0	1	Bank 1 only
0	1	1	0	Bank 2 only
0	1	1	1	Bank 3 only
1	Don't Care	Don't Care	Don't Care	All banks

READ Burst Followed by PRECHARGE

For the earliest possible precharge, the PRECHARGE command can be issued BL/2 clock cycles after a READ command. A new bank ACTIVATE command can be issued to the same bank after the row precharge time (t_{RP}) has elapsed. A PRECHARGE command cannot be issued until after t_{RAS} is satisfied.

The minimum READ-to-PRECHARGE time (t_{RTP}) must also satisfy a minimum analog time from the rising clock edge that initiates the last 4-bit prefetch of a READ command. t_{RTP} begins BL/2 - 2 clock cycles after the READ command.

If the burst is truncated by a BST command, the effective BL value is used to calculate when t_{RTP} begins.

Figure 31: READ Burst Followed by PRECHARGE – RL = 3, BL = 8, $RU(t_{RTP(MIN)}/t_{CK}) = 2$

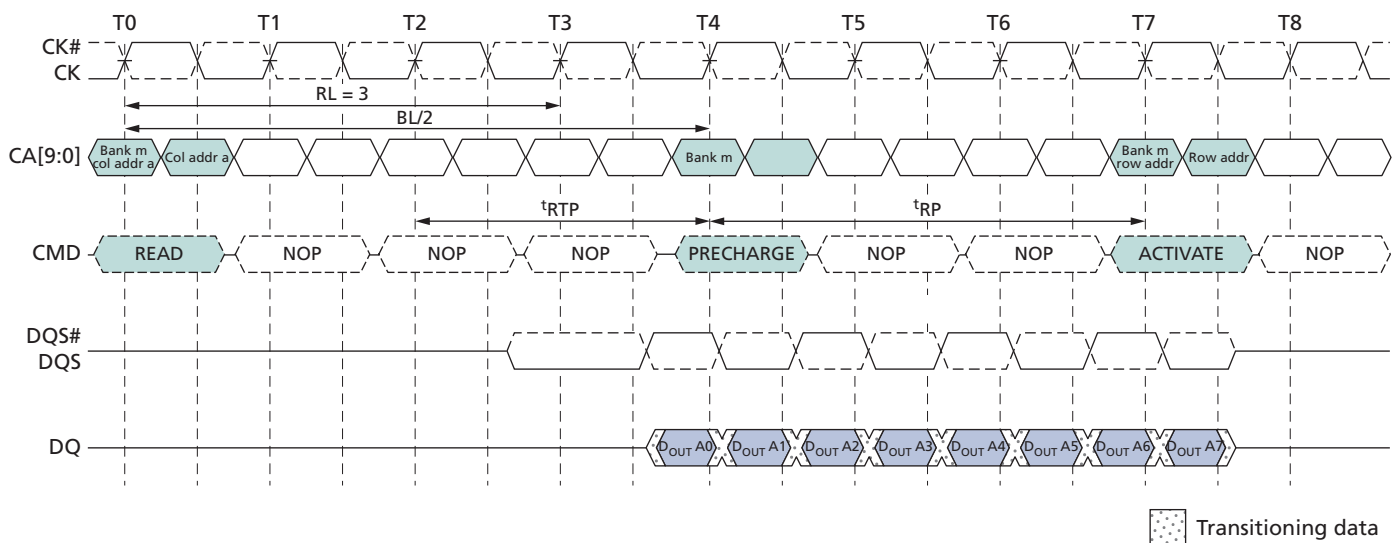
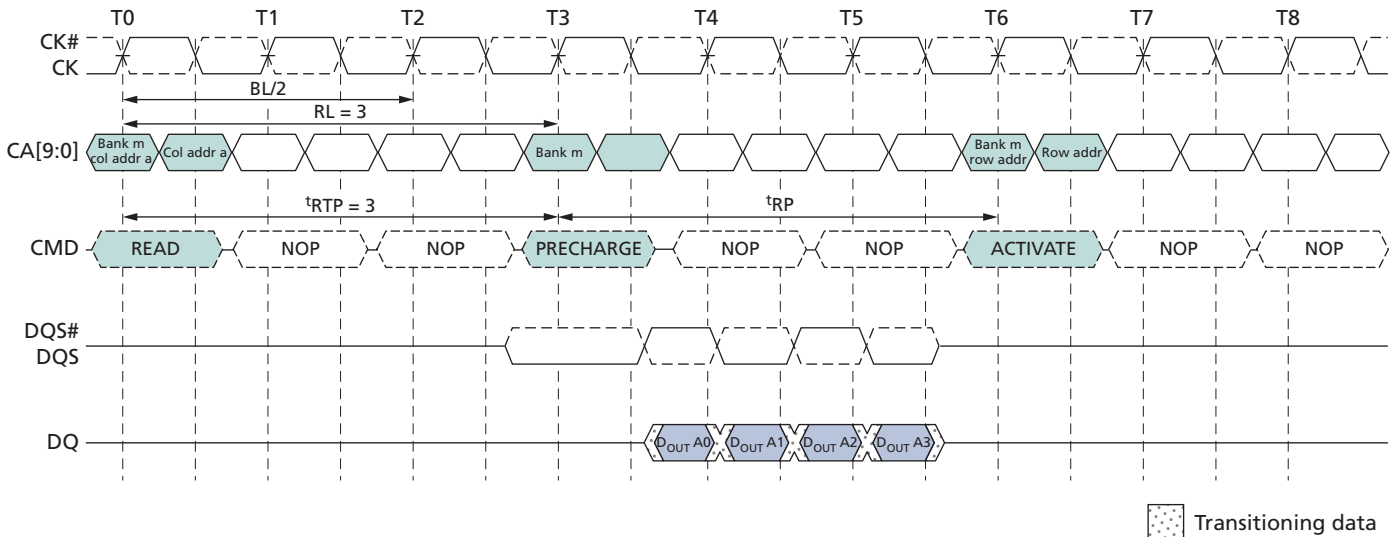

Figure 32: READ Burst Followed by PRECHARGE – RL = 3, BL = 4, $RU(t_{RTP(MIN)}/t_{CK}) = 3$



WRITE Burst Followed by PRECHARGE

For WRITE cycles, a WRITE recovery time (t_{WR}) must be provided before a PRECHARGE command can be issued. t_{WR} delay is referenced from the completion of the burst WRITE. The PRECHARGE command must not be issued prior to the t_{WR} delay. For WRITE-to-PRECHARGE timings, see the PRECHARGE and Auto Precharge Clarification table.

These devices write data to the array in prefetch quadruples (prefetch = 4). An internal WRITE operation can only begin after a prefetch group has been completely latched.

The minimum WRITE-to-PRECHARGE time for commands to the same bank is $WL + BL/2 + 1 + RU(t_{WR}/t_{CK})$ clock cycles. For untruncated bursts, BL is the value set in the mode register. For truncated bursts, BL is the effective burst length.

Figure 33: WRITE Burst Followed by PRECHARGE – WL = 1, BL = 4

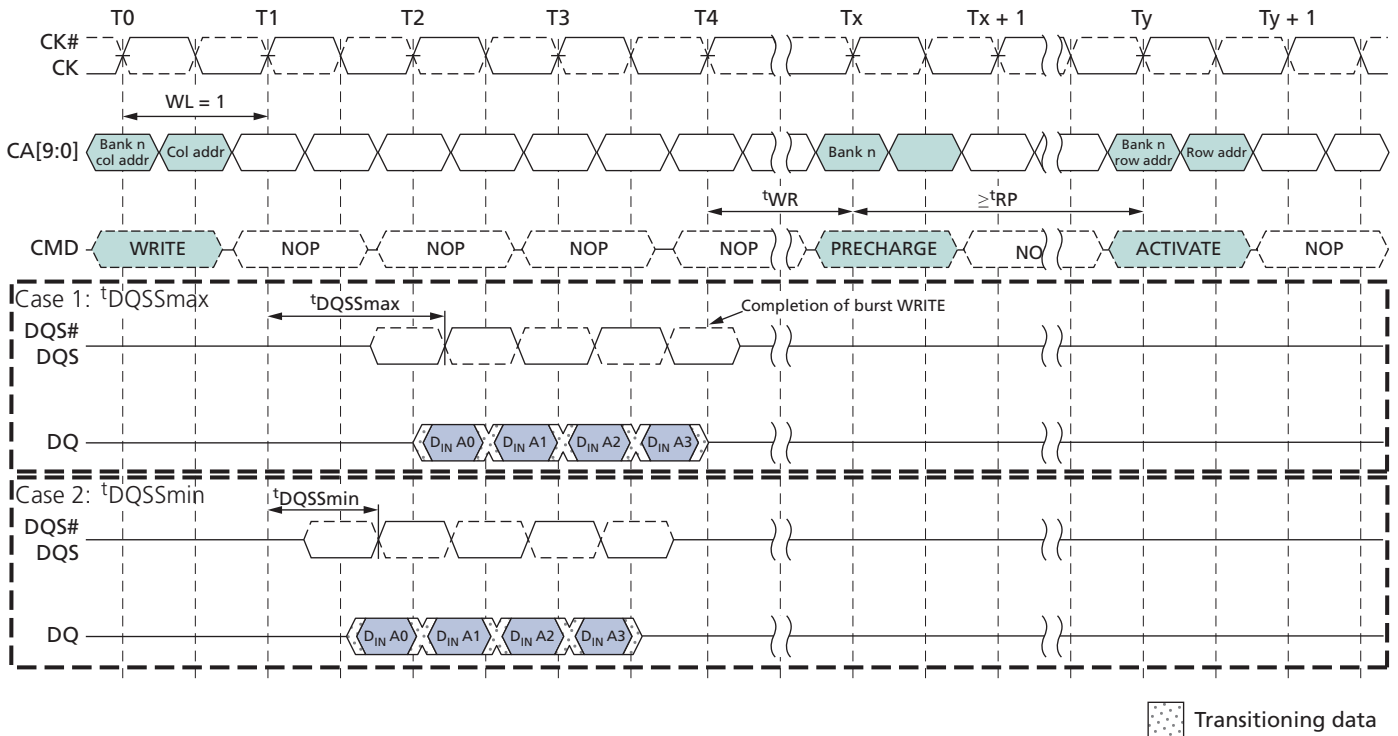

Auto Precharge

Before a new row can be opened in an active bank, the active bank must be precharged using either the PRECHARGE command or the auto precharge function. When a READ or WRITE command is issued to the device, the auto precharge bit (AP) can be set to enable the active bank to automatically begin precharge at the earliest possible moment during the burst READ or WRITE cycle.

If AP is LOW when the READ or WRITE command is issued, then normal READ or WRITE burst operation is executed and the bank remains active at the completion of the burst.

If AP is HIGH when the READ or WRITE command is issued, the auto precharge function is engaged. This feature enables the PRECHARGE operation to be partially or completely hidden during burst READ cycles (dependent upon READ or WRITE latency), thus improving system performance for random data access.

READ Burst with Auto Precharge

If AP (CA0f) is HIGH when a READ command is issued, the READ with auto precharge function is engaged.

These devices start an auto precharge on the rising edge of the clock BL/2 or BL/2 - 2 + RU (t_{RTP}/t_{CK}) clock cycles later than the READ with auto precharge command, whichever is greater. For auto precharge calculations, see the PRECHARGE and Auto Precharge Clarification table.

Following an auto precharge operation, an ACTIVATE command can be issued to the same bank if the following two conditions are satisfied simultaneously:

- The RAS precharge time (t^{RP}) has been satisfied from the clock at which the auto precharge begins.
- The RAS cycle time (t^{RC}) from the previous bank activation has been satisfied.

Figure 34: READ Burst with Auto Precharge – RL = 3, BL = 4, $RU(t^{\text{RTP(MIN)}}/t^{\text{CK}}) = 2$

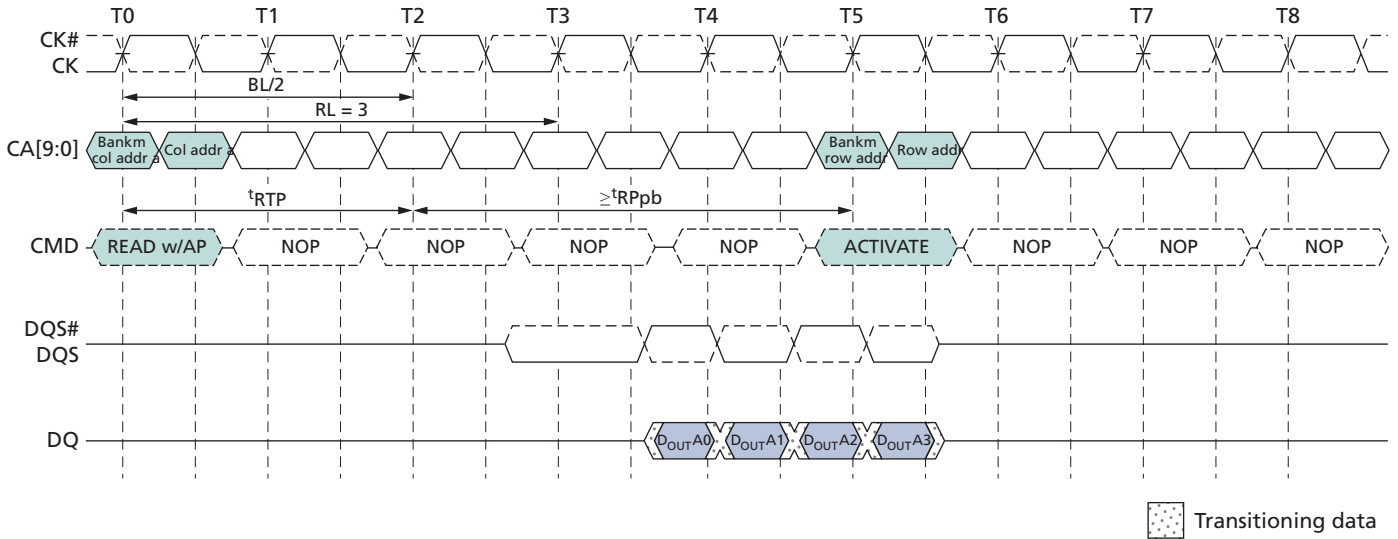

WRITE Burst with Auto Precharge

If AP (CA0f) is HIGH when a WRITE command is issued, the WRITE with auto precharge function is engaged. The device starts an auto precharge at the clock rising edge t^{WR} cycles after the completion of the burst WRITE.

Following a WRITE with auto precharge, an ACTIVATE command can be issued to the same bank if the following two conditions are met:

- The RAS precharge time (t^{RP}) has been satisfied from the clock at which the auto precharge begins.
- The RAS cycle time (t^{RC}) from the previous bank activation has been satisfied.

Figure 35: WRITE Burst with Auto Precharge – WL = 1, BL = 4

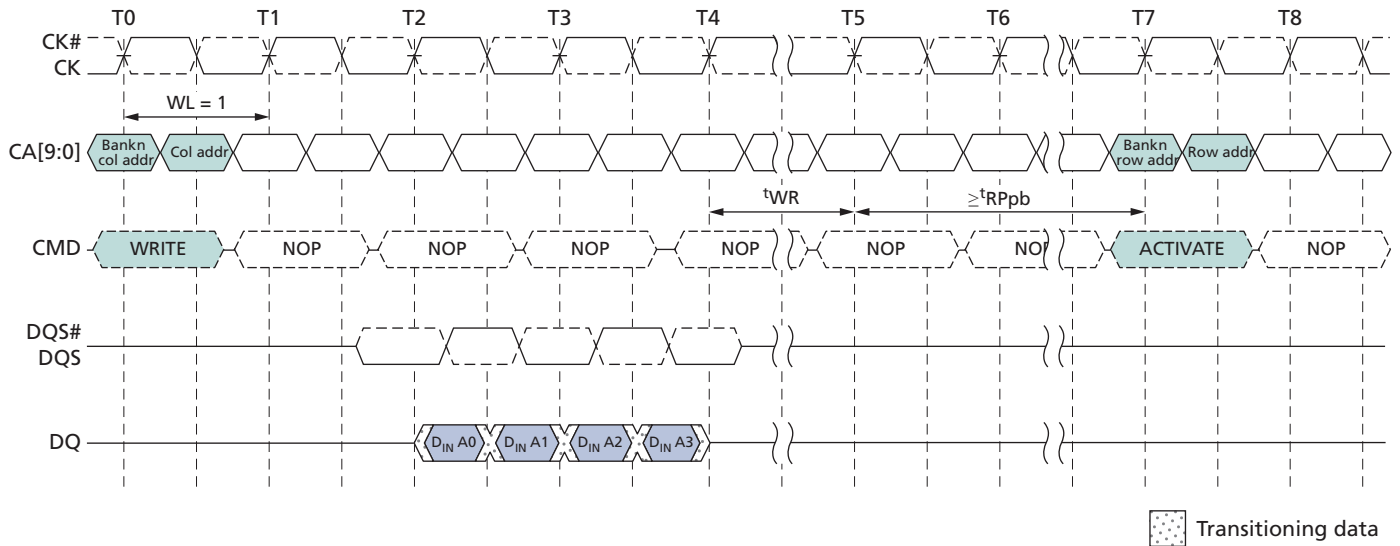

Table 42: PRECHARGE and Auto Precharge Clarification

From Command	To Command	Minimum Delay Between Commands	Unit	Notes
READ	PRECHARGE to same bank as READ	$BL/2 + \text{MAX}(2, RU(t_{RTP}/t_{CK})) - 2$	CLK	1
	PRECHARGE ALL	$BL/2 + \text{MAX}(2, RU(t_{RTP}/t_{CK})) - 2$	CLK	1
BST	PRECHARGE to same bank as READ	1	CLK	1
	PRECHARGE ALL	1	CLK	1
READ w/AP	PRECHARGE to same bank as READ w/AP	$BL/2 + \text{MAX}(2, RU(t_{RTP}/t_{CK})) - 2$	CLK	1, 2
	PRECHARGE ALL	$BL/2 + \text{MAX}(2, RU(t_{RTP}/t_{CK})) - 2$	CLK	1
	ACTIVATE to same bank as READ w/AP	$BL/2 + \text{MAX}(2, RU(t_{RTP}/t_{CK})) - 2 + RU(t_{RPpb}/t_{CK})$	CLK	1
	WRITE or WRITE w/AP (same bank)	Illegal	CLK	3
	WRITE or WRITE w/AP (different bank)	$RL + BL/2 + RU(t_{DQSCKmax}/t_{CK}) - WL + 1$	CLK	3
	READ or READ w/AP (different bank)	$BL/2$	CLK	3
WRITE	PRECHARGE to same bank as WRITE	$WL + BL/2 + RU(t_{WR}/t_{CK}) + 1$	CLK	1
	PRECHARGE ALL	$WL + BL/2 + RU(t_{WR}/t_{CK}) + 1$	CLK	1
BST	PRECHARGE to same bank as WRITE	$WL + RU(t_{WR}/t_{CK}) + 1$	CLK	1
	PRECHARGE ALL	$WL + RU(t_{WR}/t_{CK}) + 1$	CLK	1

Table 42: PRECHARGE and Auto Precharge Clarification (Continued)

From Command	To Command	Minimum Delay Between Commands	Unit	Notes
WRITE w/AP	PRECHARGE to same bank as WRITE w/AP	$WL + BL/2 + RU(t^{WR}/t^{CK}) + 1$	CLK	1, 2
	PRECHARGE ALL	$WL + BL/2 + RU(t^{WR}/t^{CK}) + 1$	CLK	1
	ACTIVATE to same bank as WRITE w/AP	$WL + BL/2 + RU(t^{WR}/t^{CK}) + 1 + RU(t^{RPpb}/t^{CK})$	CLK	1
	WRITE or WRITE w/AP (same bank)	Illegal	CLK	3
	WRITE or WRITE w/AP (different bank)	BL/2	CLK	3
	READ or READ w/AP (same bank)	Illegal	CLK	3
	READ or READ w/AP (different bank)	$WL + BL/2 + RU(t^{WTR}/t^{CK}) + 1$	CLK	3
PRECHARGE	PRECHARGE to same bank as PRECHARGE	1	CLK	1
	PRECHARGE ALL	1	CLK	1
PRECHARGE ALL	PRECHARGE	1	CLK	1
	PRECHARGE ALL	1	CLK	1

- Notes:
- For a given bank, the PRECHARGE period should be counted from the latest PRECHARGE command—either a one-bank PRECHARGE or PRECHARGE ALL—issued to that bank. The PRECHARGE period is satisfied after t^{RP} , depending on the latest PRECHARGE command issued to that bank.
 - Any command issued during the specified minimum delay time is illegal.
 - After READ with auto precharge, seamless READ operations to different banks are supported. After WRITE with auto precharge, seamless WRITE operations to different banks are supported. READ with auto precharge and WRITE with auto precharge must not be interrupted or truncated.

REFRESH Command

The REFRESH command is initiated with CS# LOW, CA0 LOW, CA1 LOW, and CA2 HIGH at the rising edge of the clock. Per-bank REFRESH is initiated with CA3 LOW at the rising edge of the clock. All-bank REFRESH is initiated with CA3 HIGH at the rising edge of the clock. Per-bank REFRESH is only supported in devices with eight banks.

A per-bank REFRESH command (REFpb) performs a per-bank REFRESH operation to the bank scheduled by the bank counter in the memory device. The bank sequence for per-bank REFRESH is fixed to be a sequential round-robin: 0-1-2-3-4-5-6-7-0-1-.... The bank count is synchronized between the controller and the SDRAM by resetting the bank count to zero. Synchronization can occur upon issuing a RESET command or at every exit from self refresh.

A bank must be idle before it can be refreshed. The controller must track the bank being refreshed by the per-bank REFRESH command.

The REFpb command must not be issued to the device until the following conditions have been met:

- t^{RFCab} has been satisfied after the prior REFab command
- t^{RFCpb} has been satisfied after the prior REFpb command
- t^{RP} has been satisfied after the prior PRECHARGE command to that bank

- t_{RRD} has been satisfied after the prior ACTIVATE command (if applicable, for example after activating a row in a different bank than the one affected by the REFpb command)

The target bank is inaccessible during per-bank REFRESH cycle time (t_{RFCpb}), however, other banks within the device are accessible and can be addressed during the cycle. During the REFpb operation, any of the banks other than the one being refreshed can be maintained in an active state or accessed by a READ or WRITE command.

When the per-bank REFRESH cycle has completed, the affected bank will be in the idle state.

After issuing REFpb, the following conditions must be met:

- t_{RFCpb} must be satisfied before issuing a REFab command
- t_{RFCpb} must be satisfied before issuing an ACTIVATE command to the same bank
- t_{RRD} must be satisfied before issuing an ACTIVATE command to a different bank
- t_{RFCpb} must be satisfied before issuing another REFpb command

An all-bank REFRESH command (REFab) issues a REFRESH command to all banks. All banks must be idle when REFab is issued (for instance, by issuing a PRECHARGE ALL command prior to issuing an all-bank REFRESH command). REFab also synchronizes the bank count between the controller and the SDRAM to zero. The REFab command must not be issued to the device until the following conditions have been met:

- t_{RFCab} has been satisfied following the prior REFab command
- t_{RFCpb} has been satisfied following the prior REFpb command
- t_{RP} has been satisfied following the prior PRECHARGE commands

After an all-bank REFRESH cycle has completed, all banks will be idle. After issuing REFab:

- t_{RFCab} latency must be satisfied before issuing an ACTIVATE command
- t_{RFCab} latency must be satisfied before issuing a REFab or REFpb command

Table 43: REFRESH Command Scheduling Separation Requirements

Symbol	Minimum Delay From	To	Notes
t_{RFCab}	REFab	REFab	
		ACTIVATE command to any bank	
		REFpb	
t_{RFCpb}	REFpb	REFab	
		ACTIVATE command to same bank as REFpb	
		REFpb	

Table 43: REFRESH Command Scheduling Separation Requirements (Continued)

Symbol	Minimum Delay From	To	Notes
^t RRD	REFpb	ACTIVATE command to a different bank than REFpb	
	ACTIVATE	REFpb	1
		ACTIVATE command to a different bank than the prior ACTIVATE command	

Note: 1. A bank must be in the idle state before it is refreshed, so REFpb is prohibited following an ACTIVATE command. REFpb is supported only if it affects a bank that is in the idle state.

Mobile LPDDR2 devices provide significant flexibility in scheduling REFRESH commands as long as the required boundary conditions are met (see the ^tSRF Definition figure).

In the most straightforward implementations, a REFRESH command should be scheduled every ^tREFI. In this case, self refresh can be entered at any time.

Users may choose to deviate from this regular refresh pattern, for instance, to enable a period in which no refresh is required. As an example, using a 1Gb LPDDR2 device, the user can choose to issue a refresh burst of 4096 REFRESH commands at the maximum supported rate (limited by ^tREFBW), followed by an extended period without issuing any REFRESH commands, until the refresh window is complete. The maximum supported time without REFRESH commands is calculated as follows: ${}^t\text{REFW} - (R/8) \times {}^t\text{REFBW} = {}^t\text{REFW} - R \times 4 \times {}^t\text{RFCab}$.

For example, a 1Gb device at $T_C \leq 85^\circ\text{C}$ can be operated without a refresh for up to 32ms - $4096 \times 4 \times 130\text{ns} \approx 30\text{ms}$.

Both the regular and the burst/pause patterns can satisfy refresh requirements if they are repeated in every 32ms window. It is critical to satisfy the refresh requirement in every rolling refresh window during refresh pattern transitions. The supported transition from a burst pattern to a regular distributed pattern is shown in the Supported Transition from Repetitive REFRESH Burst figure. If this transition occurs immediately after the burst refresh phase, all rolling ^tREFW intervals will meet the minimum required number of REFRESH commands.

A nonsupported transition is shown in Figure 38 (page 58). In this example, the regular refresh pattern starts after the completion of the pause phase of the burst/pause refresh pattern. For several rolling ^tREFW intervals, the minimum number of REFRESH commands is not satisfied.

Understanding this pattern transition is extremely important, even when only one pattern is employed. In self refresh mode, a regular distributed refresh pattern must be assumed. Micron recommends entering self refresh mode immediately following the burst phase of a burst/pause refresh pattern; upon exiting self refresh, begin with the burst phase (see the Recommended Self Refresh Entry and Exit figure).

Figure 36: Regular Distributed Refresh Pattern

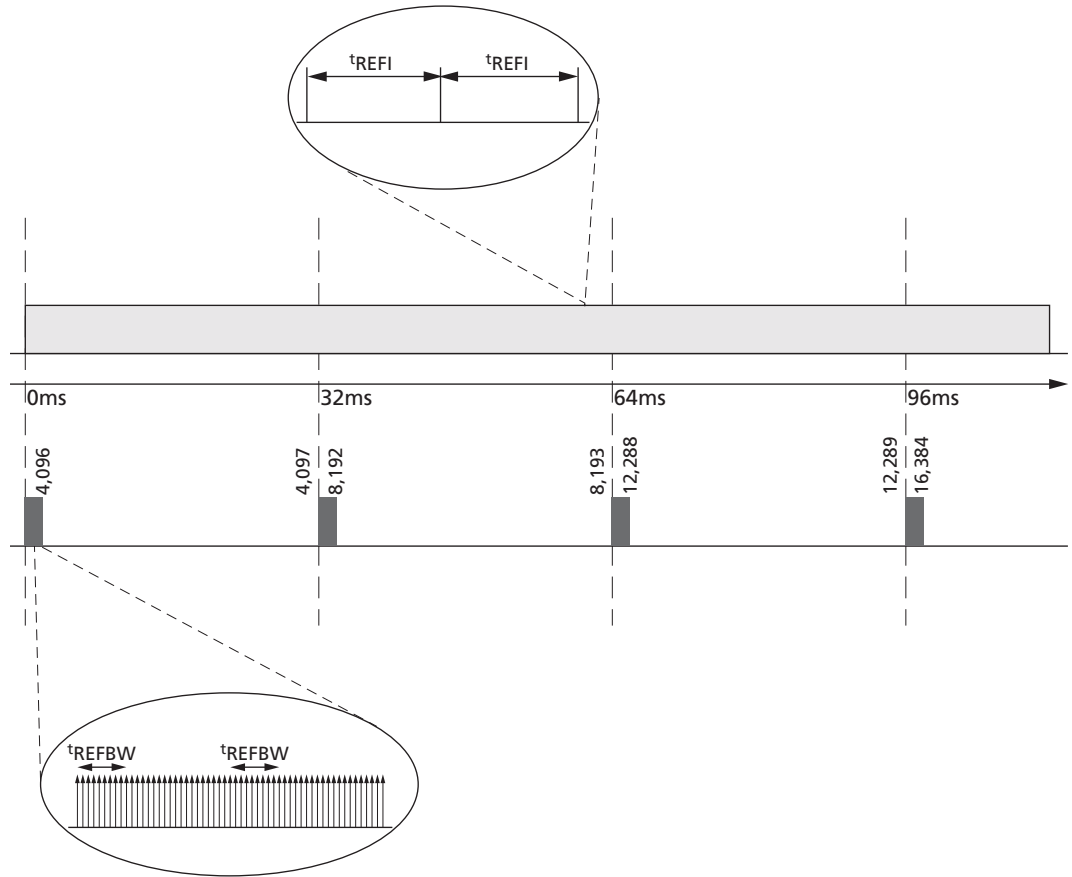

- Notes:
1. Compared to repetitive burst REFRESH with subsequent REFRESH pause.
 2. As an example, in a 1Gb LPDDR2 device at $T_C \leq 85^\circ\text{C}$, the distributed refresh pattern has one REFRESH command per $7.8\mu\text{s}$; the burst refresh pattern has one REFRESH command per $0.52\mu\text{s}$, followed by $\approx 30\text{ms}$ without any REFRESH command.

Figure 37: Supported Transition from Repetitive REFRESH Burst

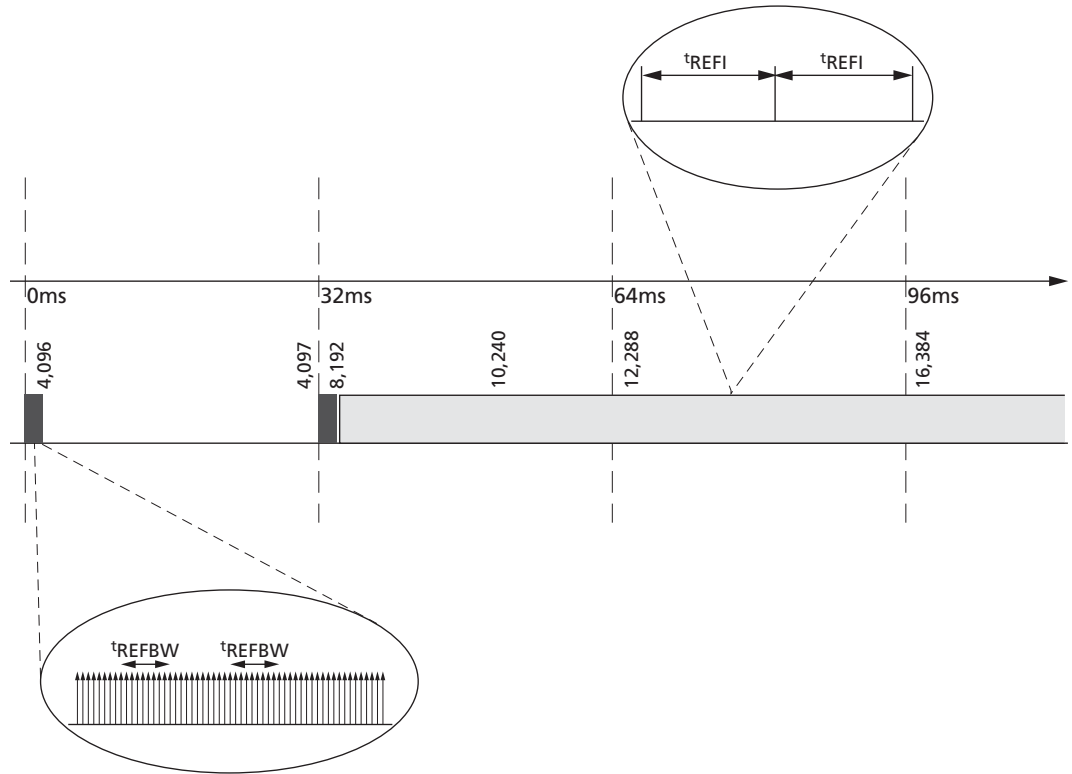

- Notes:
1. Shown with subsequent REFRESH pause to regular distributed refresh pattern.
 2. As an example, in a 1Gb LPDDR2 device at $T_C \leq 85^\circ\text{C}$, the distributed refresh pattern has one REFRESH command per $7.8\mu\text{s}$; the burst refresh pattern has one REFRESH command per $0.52\mu\text{s}$, followed by $\approx 30\text{ms}$ without any REFRESH command.

Figure 38: Nonsupported Transition from Repetitive REFRESH Burst

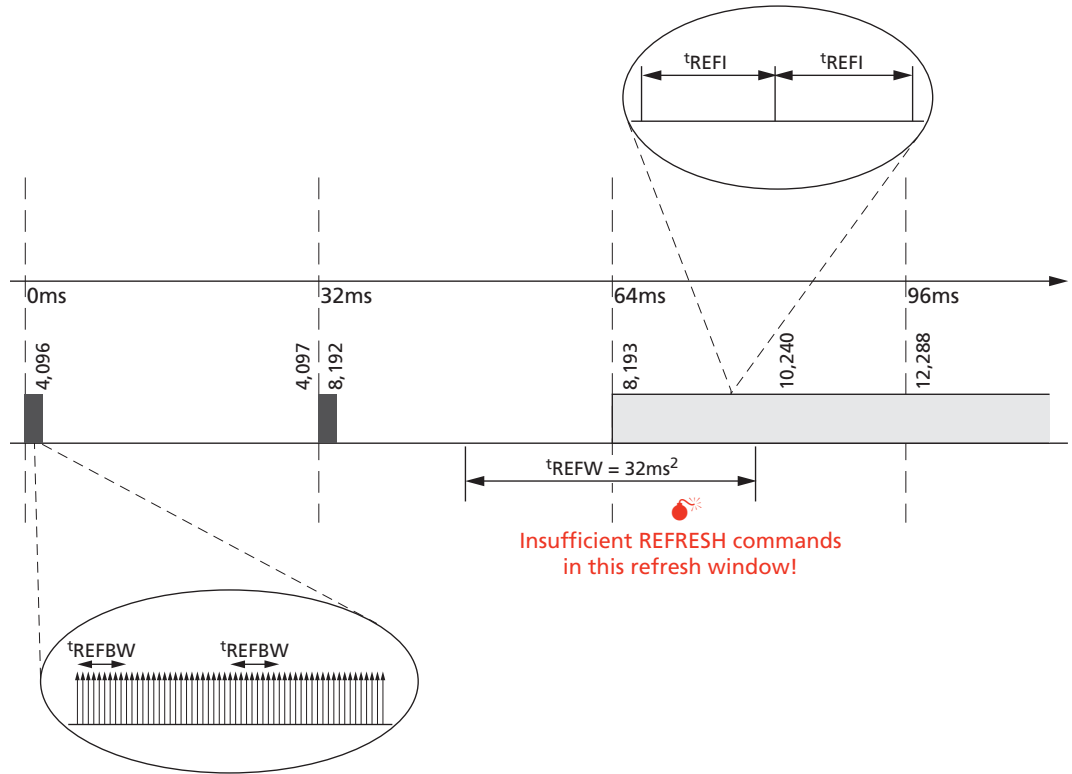

- Notes:
1. Shown with subsequent REFRESH pause to regular distributed refresh pattern.
 2. There are only ≈ 2048 REFRESH commands in the indicated t_{REFW} window. This does not provide the required minimum number of REFRESH commands (R).

Figure 39: Recommended Self Refresh Entry and Exit

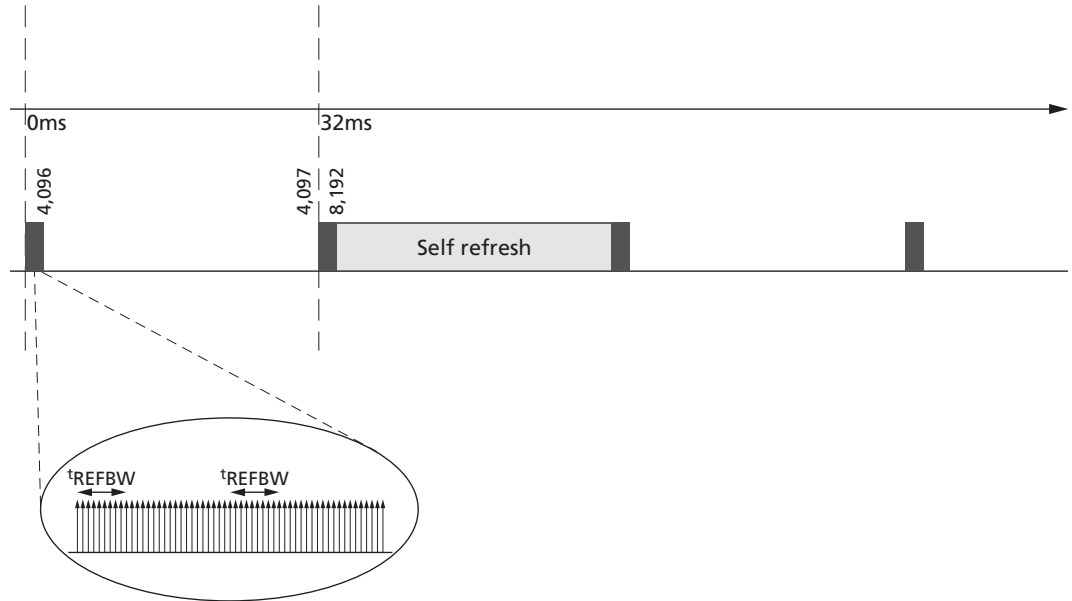

Note: 1. In conjunction with a burst/pause refresh pattern.

REFRESH Requirements

1. Minimum Number of REFRESH Commands

Mobile LPDDR2 requires a minimum number, R, of REFRESH (REFab) commands within any rolling refresh window ($t_{REFW} = 32 \text{ ms @ MR4}[2:0] = 011$ or $T_C \leq 85^\circ\text{C}$). For actual values per density and the resulting average refresh interval (t_{REFI}), see Refresh Requirements.

For t_{REFW} and t_{REFI} refresh multipliers at different MR4 settings, see the MR4 Device Temperature (MA[7:0] = 04h) table.

For devices supporting per-bank REFRESH, a REFab command can be replaced by a full cycle of eight REFpb commands.

2. Burst REFRESH Limitation

To limit current consumption, a maximum of eight REFab commands can be issued in any rolling t_{REFBW} ($t_{REFBW} = 4 \times 8 \times t_{RFCab}$). This condition does not apply if REFpb commands are used.

3. REFRESH Requirements and Self Refresh

If any time within a refresh window is spent in self refresh mode, the number of required REFRESH commands in that window is reduced to the following:

$$R' = RU \left(\frac{t_{SRF}}{t_{REFI}} \right) = R - RU \left(R \times \frac{t_{SRF}}{t_{REFW}} \right)$$

Where RU represents the round-up function.

Figure 40: t_{SRF} Definition

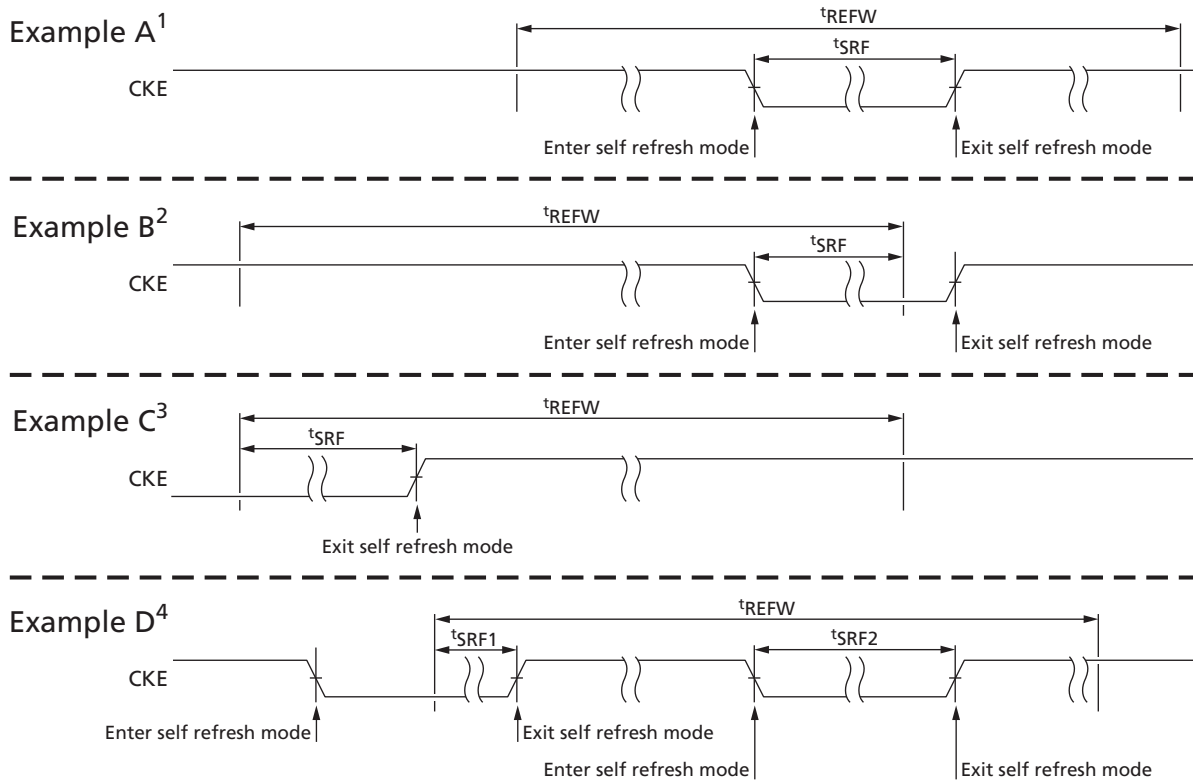

- Notes:
1. Time in self refresh mode is fully enclosed in the refresh window (t_{REFW}).
 2. At self refresh entry.
 3. At self refresh exit.
 4. Several intervals in self refresh during one t_{REFW} interval. In this example, $t_{SRF} = t_{SRF1} + t_{SRF2}$.

Figure 41: All-Bank REFRESH Operation

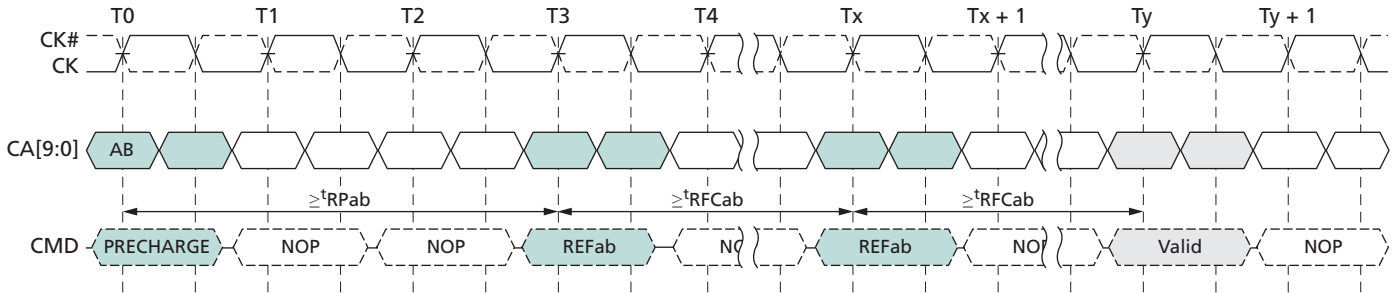

SELF REFRESH Operation

The SELF REFRESH command can be used to retain data in the array, even if the rest of the system is powered down. When in the self refresh mode, the device retains data without external clocking. The device has a built-in timer to accommodate SELF REFRESH operation. The SELF REFRESH command is executed by taking CKE LOW, CS# LOW, CA0 LOW, CA1 LOW, and CA2 HIGH at the rising edge of the clock.

CKE must be HIGH during the clock cycle preceding a SELF REFRESH command. A NOP command must be driven in the clock cycle following the SELF REFRESH command. After the power-down command is registered, CKE must be held LOW to keep the device in self refresh mode.

Mobile LPDDR2 devices can operate in self refresh mode in both the standard and extended temperature ranges. These devices also manage self refresh power consumption when the operating temperature changes, resulting in the lowest possible power consumption across the operating temperature range. See Table 61 (page 97) for details.

After the device has entered self refresh mode, all external signals other than CKE are “Don’t Care.” For proper self refresh operation, power supply pins (V_{DD1} , V_{DD2} , V_{DDQ} , and V_{DDCA}) must be at valid levels. V_{DDQ} can be turned off during self refresh. If V_{DDQ} is turned off, V_{REFDQ} must also be turned off. Prior to exiting self refresh, both V_{DDQ} and V_{REFDQ} must be within their respective minimum/maximum operating ranges (see the Single-Ended AC and DC Input Levels for DQ and DM table). V_{REFDQ} can be at any level between 0 and V_{DDQ} ; V_{REFCA} can be at any level between 0 and V_{DDCA} during self refresh.

Before exiting self refresh, V_{REFDQ} and V_{REFCA} must be within specified limits (see AC and DC Logic Input Measurement Levels for Single-Ended Signals (page 98)). After entering self refresh mode, the device initiates at least one all-bank REFRESH command internally during t_{CKESR} . The clock is internally disabled during SELF REFRESH operation to save power. The device must remain in self refresh mode for at least t_{CKESR} . The user can change the external clock frequency or halt the external clock one clock after self refresh entry is registered; however, the clock must be restarted and stable before the device can exit SELF REFRESH operation.

Exiting self refresh requires a series of commands. First, the clock must be stable prior to CKE returning HIGH. After the self refresh exit is registered, a minimum delay, at least equal to the self refresh exit interval (t_{XSR}), must be satisfied before a valid command can be issued to the device. This provides completion time for any internal refresh in

progress. For proper operation, CKE must remain HIGH throughout t^{XSR} . NOP commands must be registered on each rising clock edge during t^{XSR} .

Using self refresh mode introduces the possibility that an internally timed refresh event could be missed when CKE is driven HIGH for exit from self refresh mode. Upon exiting self refresh, at least one REFRESH command (one all-bank command or eight per-bank commands) must be issued before issuing a subsequent SELF REFRESH command.

Figure 42: SELF REFRESH Operation

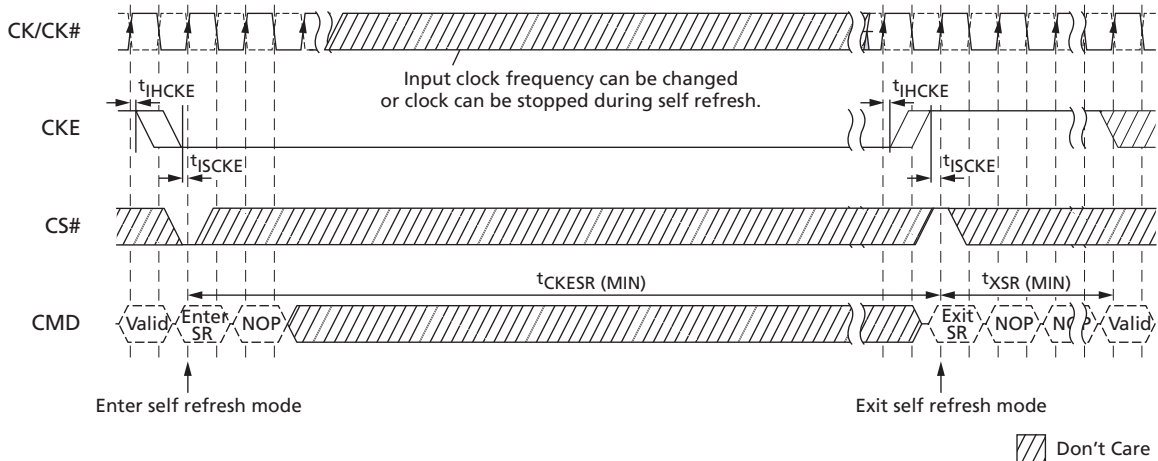

- Notes:
1. Input clock frequency can be changed or stopped during self refresh, provided that upon exiting self refresh, a minimum of two cycles of stable clocks are provided, and the clock frequency is between the minimum and maximum frequencies for the particular speed grade.
 2. The device must be in the all banks idle state prior to entering self refresh mode.
 3. t^{XSR} begins at the rising edge of the clock after CKE is driven HIGH.
 4. A valid command can be issued only after t^{XSR} is satisfied. NOPs must be issued during t^{XSR} .

Partial-Array Self Refresh – Bank Masking

Devices in densities of 64Mb–512Mb are comprised of four banks; densities of 1Gb and higher are comprised of eight banks. Each bank can be configured independently whether or not a SELF REFRESH operation will occur in that bank. One 8-bit mode register (accessible via the MRW command) is assigned to program the bank-masking status of each bank up to eight banks. For bank masking bit assignments, see the MR16 PASR Bank Mask (MA[7:0] = 010h) and MR16 Op-Code Bit Definitions tables.

The mask bit to the bank enables or disables a refresh operation of the entire memory space within the bank. If a bank is masked using the bank mask register, a REFRESH operation to the entire bank is blocked and bank data retention is not guaranteed in self refresh mode. To enable a REFRESH operation to a bank, the corresponding bank mask bit must be programmed as “unmasked.” When a bank mask bit is unmasked, the array space being refreshed within that bank is determined by the programmed status of the segment mask bits.

Partial-Array Self Refresh – Segment Masking

Programming segment mask bits is similar to programming bank mask bits. For densities 1Gb and higher, eight segments are used for masking (see the MR17 PASR Segment Mask (MA[7:0] = 011h) and MR17 PASR Segment Mask Definitions tables). A mode register is used for programming segment mask bits up to eight bits. For densities less than 1Gb, segment masking is not supported.

When the mask bit to an address range (represented as a segment) is programmed as “masked,” a REFRESH operation to that segment is blocked. Conversely, when a segment mask bit to an address range is unmasked, refresh to that segment is enabled.

A segment masking scheme can be used in place of or in combination with a bank masking scheme. Each segment mask bit setting is applied across all banks. For segment masking bit assignments, see the tables noted above.

Table 44: Bank and Segment Masking Example

	Segment Mask (MR17)	Bank 0	Bank 1	Bank 2	Bank 3
Bank Mask (MR16)		0	1	0	0
Segment 0	0	–	M	–	–
Segment 1	0	–	M	–	–
Segment 2	1	M	M	M	M
Segment 3	0	–	M	–	–
Segment 4	0	–	M	–	–
Segment 5	0	–	M	–	–
Segment 6	0	–	M	–	–
Segment 7	1	M	M	M	M

Note: 1. This table provides values for an 4-bank device with REFRESH operations masked to banks 1 and 3, and segments 2 and 7.

MODE REGISTER READ

The MODE REGISTER READ (MRR) command is used to read configuration and status data from SDRAM mode registers. The MRR command is initiated with CS# LOW, CA0 LOW, CA1 LOW, CA2 LOW, and CA3 HIGH at the rising edge of the clock. The mode register is selected by CA1f–CA0f and CA9r–CA4r. The mode register contents are available on the first data beat of DQ[7:0] after $RL \times ^tCK + ^tDQSCK + ^tDQSQ$ and following the rising edge of the clock where MRR is issued. Subsequent data beats contain valid but undefined content, except in the case of the DQ calibration function, where subsequent data beats contain valid content as described in the Data Calibration Pattern Description table. All DQS are toggled for the duration of the mode register READ burst.

The MRR command has a burst length of four. MRR operation (consisting of the MRR command and the corresponding data traffic) must not be interrupted. The MRR command period (tMRR) is two clock cycles.

Figure 43: MRR Timing – $RL = 3$, $^tMRR = 2$

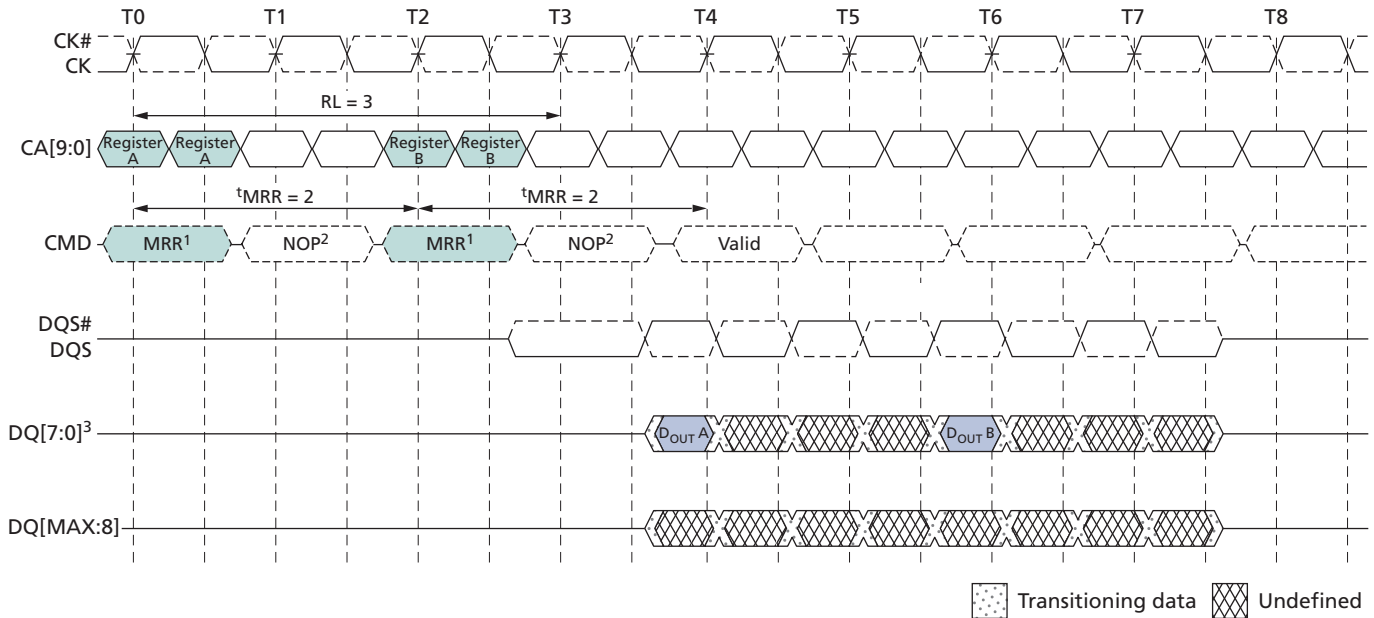

- Notes:
1. MRRs to DQ calibration registers MR32 and MR40 are described in Data Calibration.
 2. Only the NOP command is supported during tMRR .
 3. Mode register data is valid only on DQ[7:0] on the first beat. Subsequent beats contain valid but undefined data. DQ[MAX:8] contain valid but undefined data for the duration of the MRR burst.
 4. Minimum MRR to write latency is $RL + RU(^tDQSCK_{max}/^tCK) + 4/2 + 1 - WL$ clock cycles.
 5. Minimum MRR to MRW latency is $RL + RU(^tDQSCK_{max}/^tCK) + 4/2 + 1$ clock cycles.

READ bursts and WRITE bursts cannot be truncated by MRR. Following a READ command, the MRR command must not be issued before $BL/2$ clock cycles have completed. Following a WRITE command, the MRR command must not be issued before $WL + 1 + BL/2 + RU(^tWTR/^tCK)$ clock cycles have completed. If a READ or WRITE burst is truncated with a BST command, the effective burst length of the truncated burst should be used for the BL value.

Figure 44: READ to MRR Timing – RL = 3, $t^{\text{MRR}} = 2$

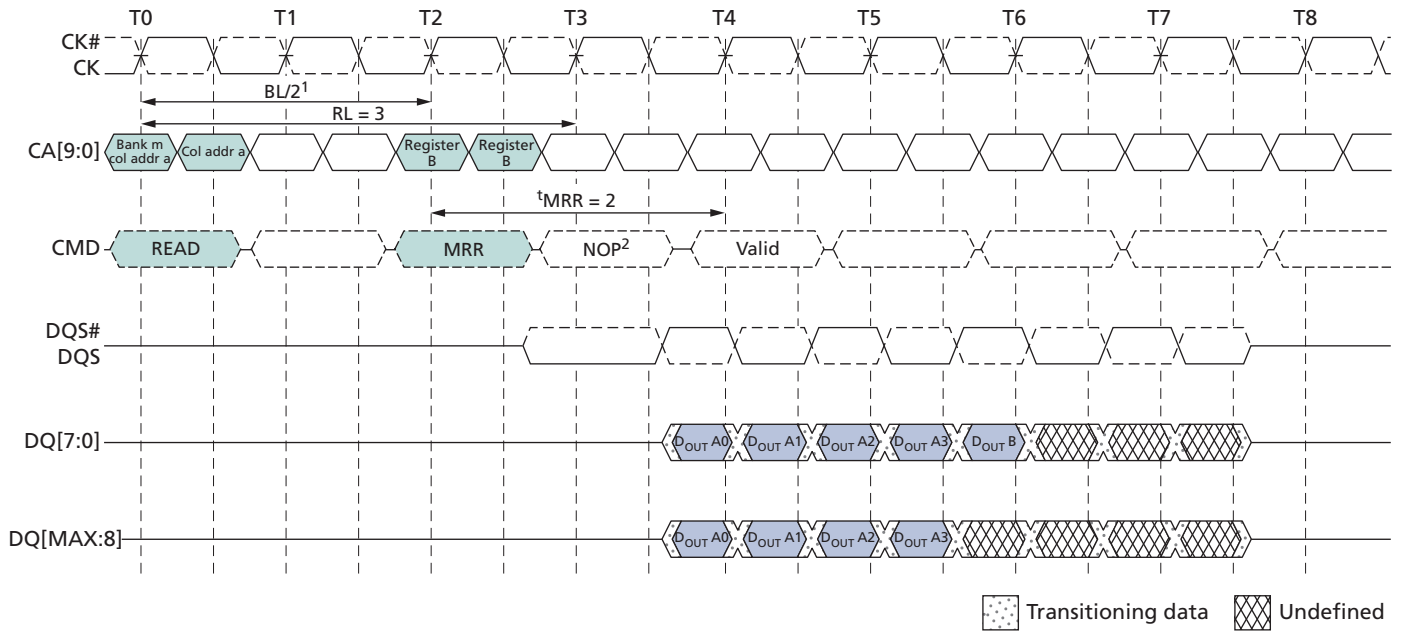

- Notes:
1. The minimum number of clock cycles from the burst READ command to the MRR command is BL/2.
 2. Only the NOP command is supported during t^{MRR} .

Figure 45: Burst WRITE Followed by MRR – RL = 3, WL = 1, BL = 4

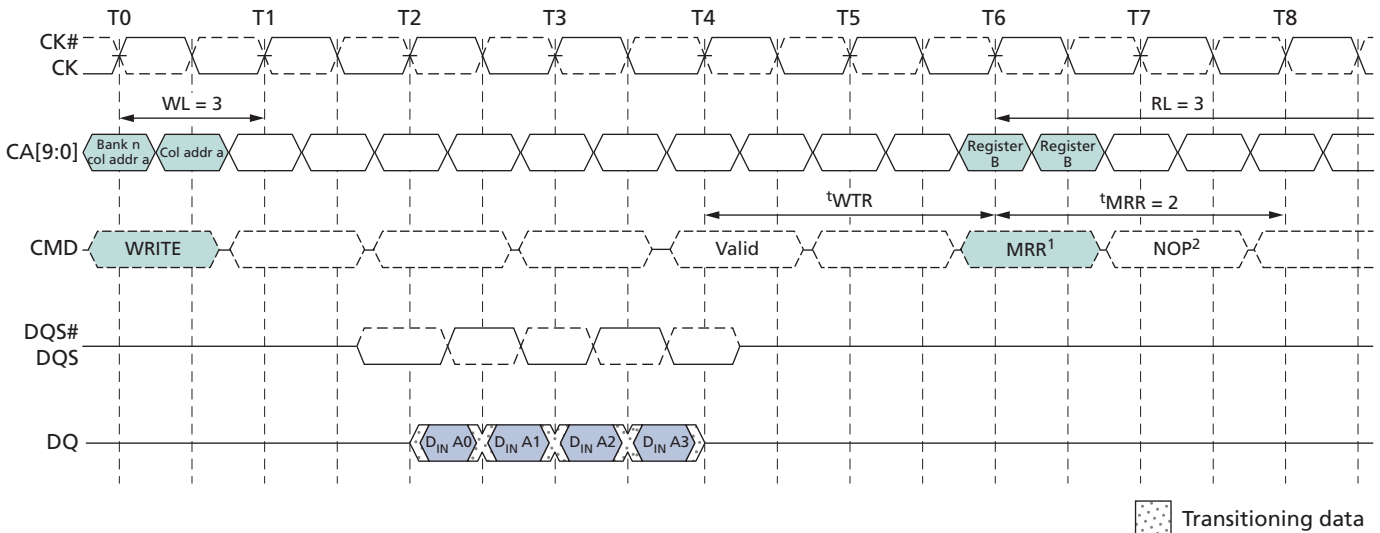

- Notes:
1. The minimum number of clock cycles from the burst WRITE command to the MRR command is $[WL + 1 + BL/2 + RU(t_{WTR}/t_{CK})]$.
 2. Only the NOP command is supported during t_{MRR} .

Temperature Sensor

Mobile LPDDR2 devices feature a temperature sensor whose status can be read from MR4. This sensor can be used to determine an appropriate refresh rate, determine whether AC timing derating is required in the extended temperature range, and/or monitor the operating temperature. Either the temperature sensor or the device operating temperature can be used to determine whether operating temperature requirements are being met (see Operating Temperature Range table).

Temperature sensor data can be read from MR4 using the mode register read protocol. Upon exiting self-refresh or power-down, the device temperature status bits will be no older than t_{TSI} .

When using the temperature sensor, the actual device case temperature may be higher than the operating temperature specification that applies for the standard or extended temperature ranges (see table noted above). For example, T_{CASE} could be above 85°C when MR4[2:0] equals 011b.

To ensure proper operation using the temperature sensor, applications must accommodate the parameters in the temperature sensor definitions table.

Table 45: Temperature Sensor Definitions and Operating Conditions

Parameter	Description	Symbol	Min/Max	Value	Unit
System temperature gradient	Maximum temperature gradient experienced by the memory device at the temperature of interest over a range of 2°C	TempGradient	MAX	System-dependent	°C/s
MR4 READ interval	Time period between MR4 READs from the system	ReadInterval	MAX	System-dependent	ms
Temperature sensor interval	Maximum delay between internal updates of MR4	^t TSI	MAX	32	ms
System response delay	Maximum response time from an MR4 READ to the system response	SysRespDelay	MAX	System-dependent	ms
Device temperature margin	Margin above maximum temperature to support controller response	TempMargin	MAX	2	°C

Mobile LPDDR2 devices accommodate the temperature margin between the point at which the device temperature enters the extended temperature range and the point at which the controller reconfigures the system accordingly. To determine the required MR4 polling frequency, the system must use the maximum TempGradient and the maximum response time of the system according to the following equation:

$$\text{TempGradient} \times (\text{ReadInterval} + {}^t\text{TSI} + \text{SysRespDelay}) \leq 2^\circ\text{C}$$

For example, if TempGradient is 10°C/s and the SysRespDelay is 1ms:

$$\frac{10^\circ\text{C}}{\text{s}} \times (\text{ReadInterval} + 32\text{ms} + 1\text{ms}) \leq 2^\circ\text{C}$$

In this case, ReadInterval must not exceed 167ms.

Figure 46: Temperature Sensor Timing

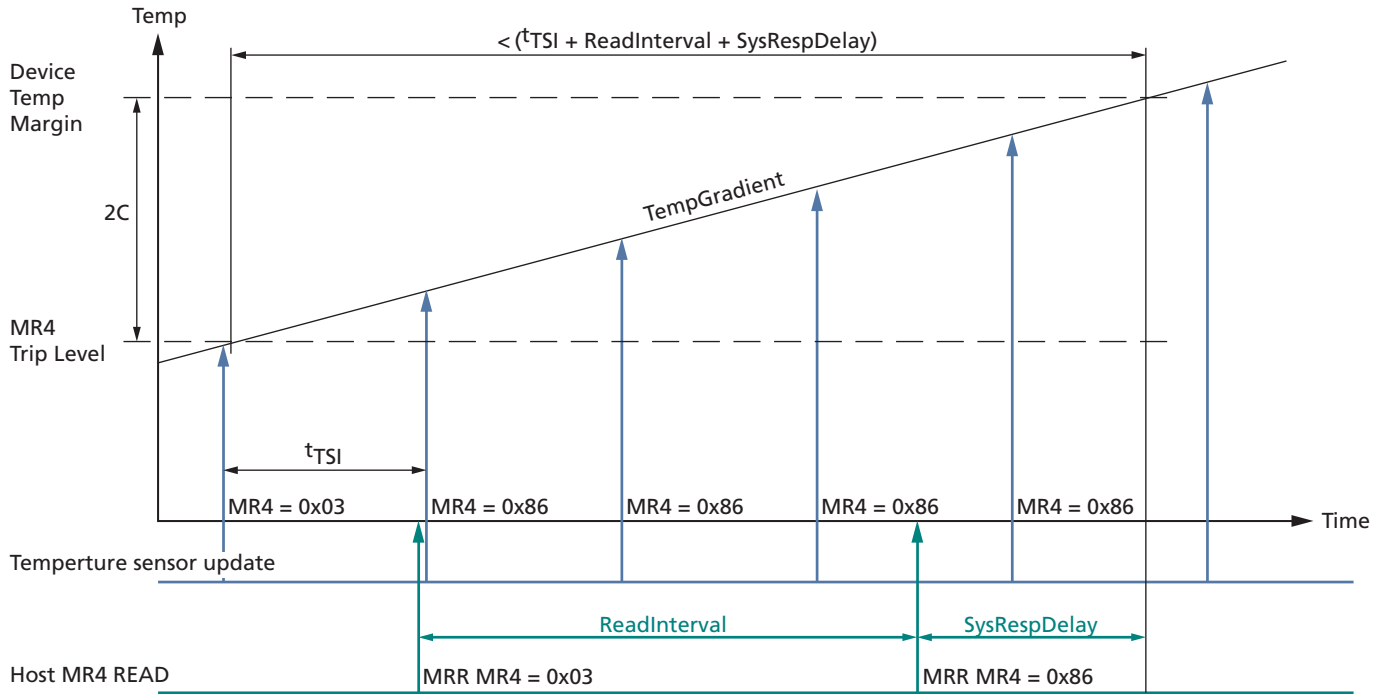

DQ Calibration

Mobile LPDDR2 devices feature a DQ calibration function that outputs one of two pre-defined system timing calibration patterns. For x16 devices, pattern A (MRR to MRR32), and pattern B (MRR to MRR40), will return the specified pattern on DQ0 and DQ8; x32 devices return the specified pattern on DQ0, DQ8, DQ16, and DQ24.

For x16 devices, DQ[7:1] and DQ[15:9] drive the same information as DQ0 during the MRR burst. For x32 devices, DQ[7:1], DQ[15:9], DQ[23:17], and DQ[31:25] drive the same information as DQ0 during the MRR burst. MRR DQ calibration commands can occur only in the idle state.

Figure 47: MR32 and MR40 DQ Calibration Timing – RL = 3, $t_{MRR} = 2$

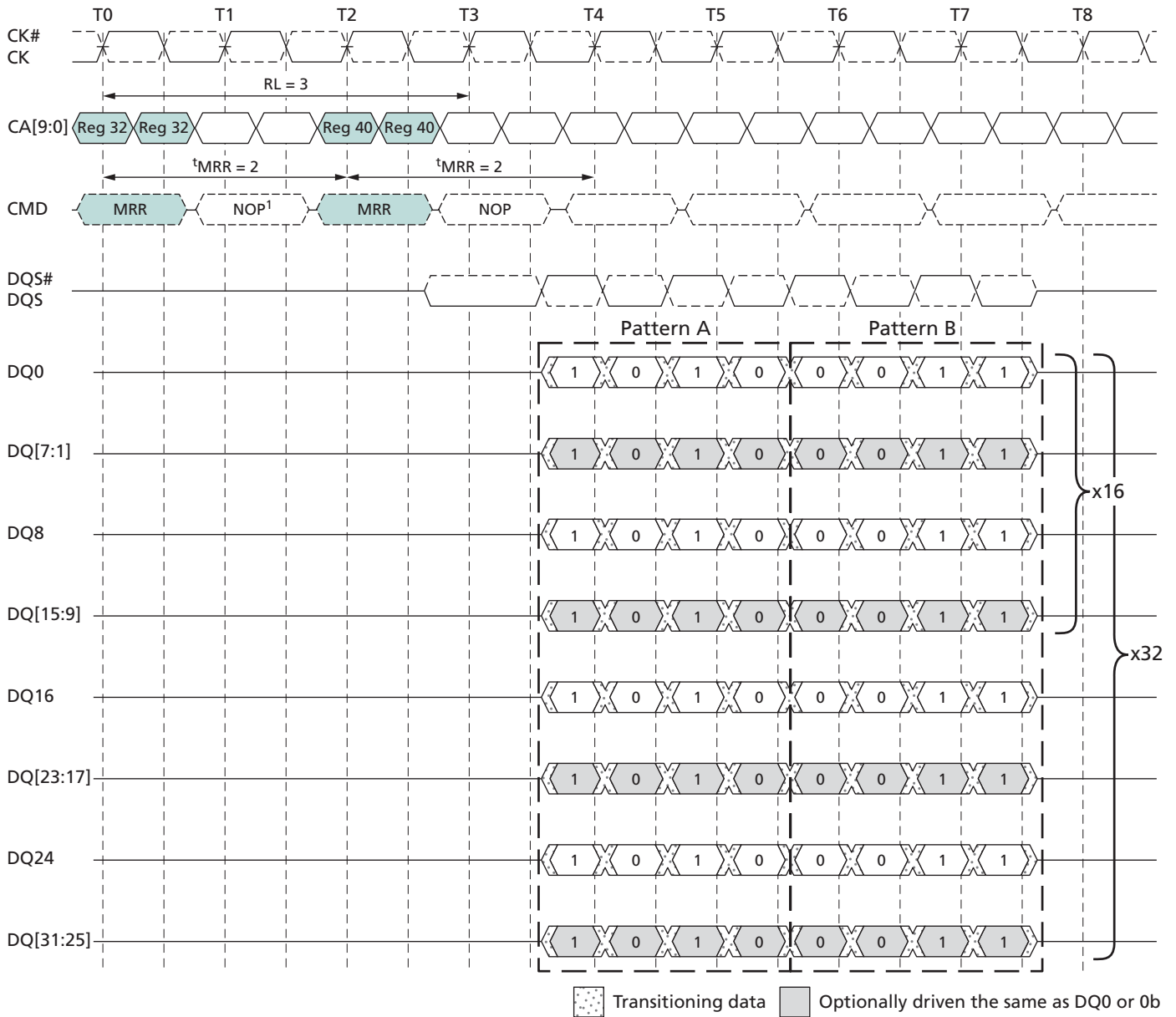

Note: 1. Only the NOP command is supported during t_{MRR} .

Table 46: Data Calibration Pattern Description

Pattern	MR#	Bit Time 0	Bit Time 1	Bit Time 2	Bit Time 3	Description
Pattern A	MR32	1	0	1	0	Reads to MR32 return DQ calibration pattern A
Pattern B	MR40	0	0	1	1	Reads to MR40 return DQ calibration pattern B

MODE REGISTER WRITE Command

The MODE REGISTER WRITE (MRW) command is used to write configuration data to the mode registers. The MRW command is initiated with CS# LOW, CA0 LOW, CA1 LOW, CA2 LOW, and CA3 LOW at the rising edge of the clock. The mode register is selected by CA1f–CA0f, CA9r–CA4r. The data to be written to the mode register is contained in CA9f–CA2f. The MRW command period is defined by t_{MRW} . MRWs to read-only registers have no impact on the functionality of the device.

MRW can only be issued when all banks are in the idle precharge state. One method of ensuring that the banks are in this state is to issue a PRECHARGE ALL command.

Figure 48: MODE REGISTER WRITE Timing – RL = 3, $t_{MRW} = 5$

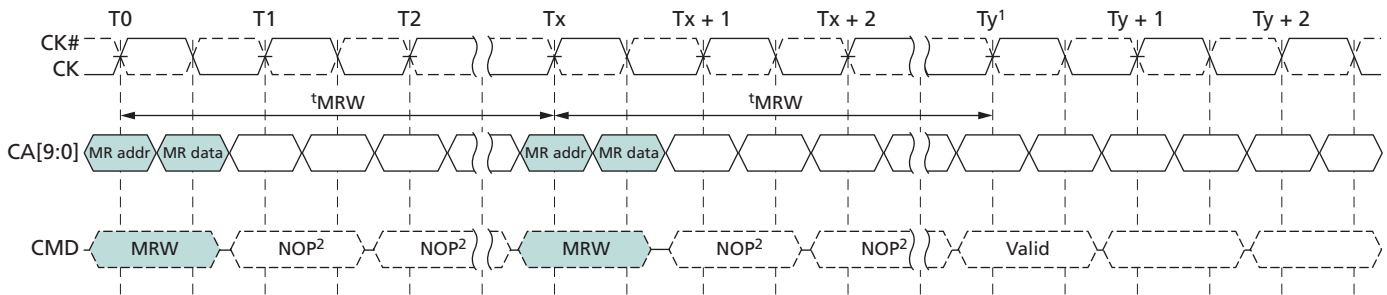

- Notes: 1. At time T_y , the device is in the idle state.
2. Only the NOP command is supported during t_{MRW} .

Table 47: Truth Table for MRR and MRW

Current State	Command	Intermediate State	Next State
All banks idle	MRR	Reading mode register, all banks idle	All banks idle
	MRW	Writing mode register, all banks idle	All banks idle
	MRW (RESET)	Resetting, device auto initialization	All banks idle
Bank(s) active	MRR	Reading mode register, bank(s) idle	Bank(s) active
	MRW	Not allowed	Not allowed
	MRW (RESET)	Not allowed	Not allowed

MRW RESET Command

The MRW RESET command brings the device to the device auto initialization (resetting) state in the power-on initialization sequence (see 2. RESET Command under Power-Up (page 20)). The MRW RESET command can be issued from the idle state. This command resets all mode registers to their default values. Only the NOP command is supported during t_{INIT4} . After MRW RESET, boot timings must be observed until the device initialization sequence is complete and the device is in the idle state. Array data is undefined after the MRW RESET command has completed.

For MRW RESET timing, see Figure 10 (page 22).

MRW ZQ Calibration Commands

The MRW command is used to initiate a ZQ calibration command that calibrates output driver impedance across process, temperature, and voltage. LPDDR2-S4 devices support ZQ calibration. To achieve tighter tolerances, proper ZQ calibration must be performed.

There are four ZQ calibration commands and related timings: t_{ZQINIT} , $t_{ZQRESET}$, t_{ZQCL} , and t_{ZQCS} . t_{ZQINIT} is used for initialization calibration; $t_{ZQRESET}$ is used for resetting ZQ to the default output impedance; t_{ZQCL} is used for long calibration(s); and t_{ZQCS} is used for short calibration(s). See the MR10 Calibration (MA[7:0] = 0Ah) table for ZQ calibration command code definitions.

ZQINIT must be performed for LPDDR2 devices. ZQINIT provides an output impedance accuracy of $\pm 15\%$. After initialization, the ZQ calibration long (ZQCL) can be used to recalibrate the system to an output impedance accuracy of $\pm 15\%$. A ZQ calibration short (ZQCS) can be used periodically to compensate for temperature and voltage drift in the system.

ZQRESET resets the output impedance calibration to a default accuracy of $\pm 30\%$ across process, voltage, and temperature. This command is used to ensure output impedance accuracy to $\pm 30\%$ when ZQCS and ZQCL commands are not used.

One ZQCS command can effectively correct at least 1.5% (ZQ correction) of output impedance errors within t_{ZQCS} for all speed bins, assuming the maximum sensitivities specified in Table 78 and Table 79 (page 113) are met. The appropriate interval between ZQCS commands can be determined using these tables and system-specific parameters.

Mobile LPDDR2 devices are subject to temperature drift rate ($T_{driftrate}$) and voltage drift rate ($V_{driftrate}$) in various applications. To accommodate drift rates and calculate the necessary interval between ZQCS commands, apply the following formula:

$$\frac{ZQ_{correction}}{(T_{sens} \times T_{driftrate}) + (V_{sens} \times V_{driftrate})}$$

Where $T_{sens} = \text{MAX}(dR_{ON}dT)$ and $V_{sens} = \text{MAX}(dR_{ON}dV)$ define temperature and voltage sensitivities.

For example, if $T_{sens} = 0.75\%/^{\circ}\text{C}$, $V_{sens} = 0.20\%/mV$, $T_{driftrate} = 1^{\circ}\text{C}/\text{sec}$, and $V_{driftrate} = 15\text{ mV}/\text{sec}$, then the interval between ZQCS commands is calculated as:

$$\frac{1.5}{(0.75 \times 1) + (0.20 \times 15)} = 0.4s$$

A ZQ calibration command can only be issued when the device is in the idle state with all banks precharged.

No other activities can be performed on the data bus during calibration periods (t_{ZQINIT} , t_{ZQCL} , or t_{ZQCS}). The quiet time on the data bus helps to accurately calibrate output impedance. There is no required quiet time after the ZQRESET command. If multiple devices share a single ZQ resistor, only one device can be calibrating at any given time. After calibration is complete, the ZQ ball circuitry is disabled to reduce power consumption.

In systems sharing a ZQ resistor between devices, the controller must prevent t_{ZQINIT} , t_{ZQCS} , and t_{ZQCL} overlap between the devices. ZQRESET overlap is acceptable. If the ZQ resistor is absent from the system, ZQ must be connected to V_{DDCA} . In this situation, the device must ignore ZQ calibration commands and the device will use the default calibration settings.

Figure 49: ZQ Timings

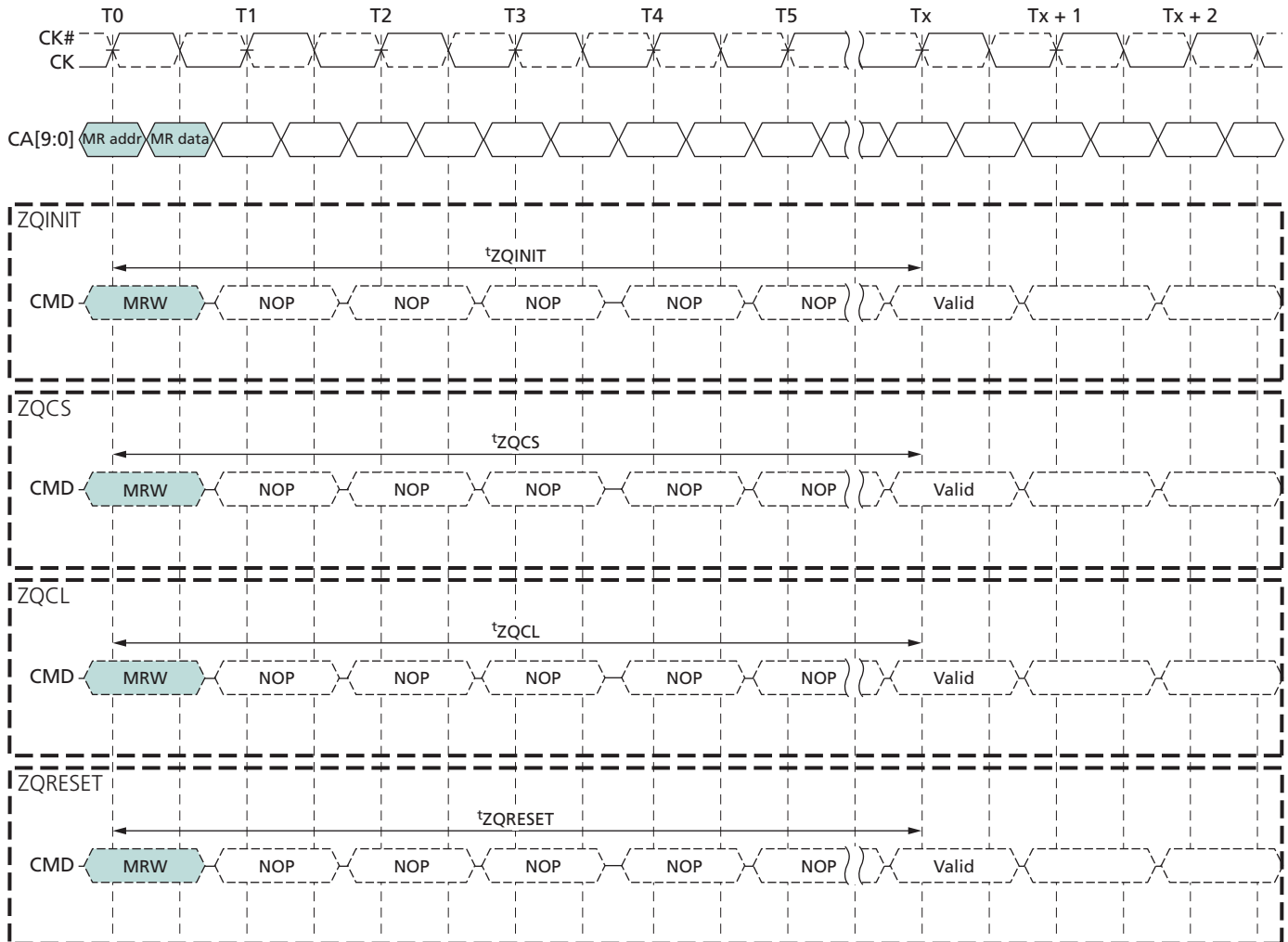

- Notes:
1. Only the NOP command is supported during ZQ calibrations.
 2. CKE must be registered HIGH continuously during the calibration period.
 3. All devices connected to the DQ bus should be High-Z during the calibration process.

ZQ External Resistor Value, Tolerance, and Capacitive Loading

To use the ZQ calibration function, a 240 ohm ($\pm 1\%$ tolerance) external resistor must be connected between the ZQ pin and ground. A single resistor can be used for each device or one resistor can be shared between multiple devices if the ZQ calibration timings for each device do not overlap. The total capacitive loading on the ZQ pin must be limited (see the Input/Output Capacitance table).

Power-Down

Power-down is entered synchronously when CKE is registered LOW and CS# is HIGH at the rising edge of clock. A NOP command must be driven in the clock cycle following power-down entry. CKE must not go LOW while MRR, MRW, READ, or WRITE operations are in progress. CKE can go LOW while any other operations such as ACTIVATE, PRECHARGE, auto precharge, or REFRESH are in progress, but the power-down I_{DD} specification will not be applied until such operations are complete.

If power-down occurs when all banks are idle, this mode is referred to as idle power-down; if power-down occurs when there is a row active in any bank, this mode is referred to as active power-down.

Entering power-down deactivates the input and output buffers, excluding CK, CK#, and CKE. In power-down mode, CKE must be held LOW; all other input signals are “Don’t Care.” CKE LOW must be maintained until t_{CKE} is satisfied. V_{REFCA} must be maintained at a valid level during power-down.

V_{DDQ} can be turned off during power-down. If V_{DDQ} is turned off, V_{REFDQ} must also be turned off. Prior to exiting power-down, both V_{DDQ} and V_{REFDQ} must be within their respective minimum/maximum operating ranges (see AC and DC Operating Conditions).

No refresh operations are performed in power-down mode. The maximum duration in power-down mode is only limited by the refresh requirements outlined in REFRESH Command.

The power-down state is exited when CKE is registered HIGH. The controller must drive CS# HIGH in conjunction with CKE HIGH when exiting the power-down state. CKE HIGH must be maintained until t_{CKE} is satisfied. A valid, executable command can be applied with power-down exit latency t_{XP} after CKE goes HIGH. Power-down exit latency is defined in the AC Timing section.

Figure 50: Power-Down Entry and Exit Timing

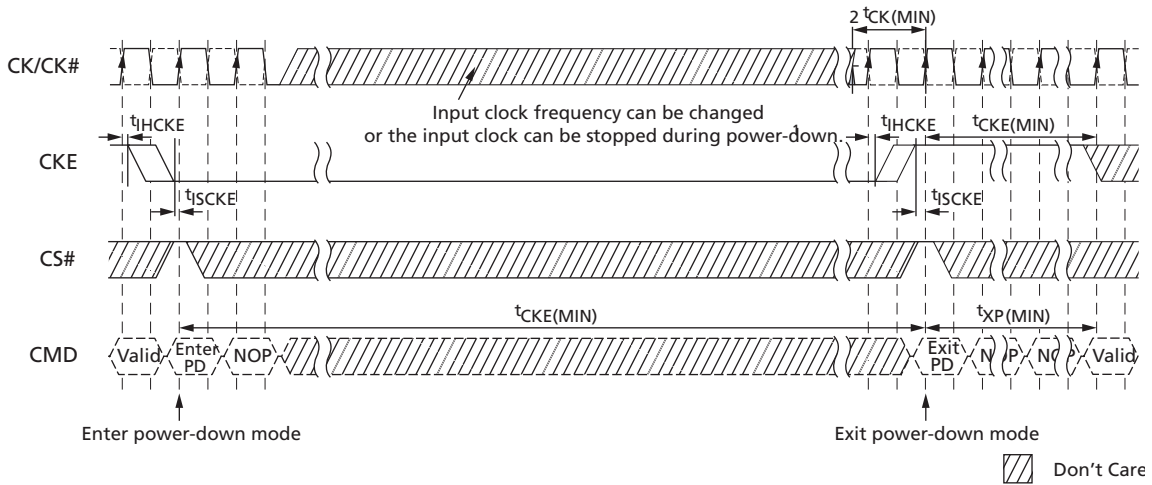

Note: 1. Input clock frequency can be changed or the input clock stopped during power-down, provided that the clock frequency is between the minimum and maximum specified frequencies for the speed grade in use, and that prior to power-down exit, a minimum of two stable clocks complete.

Figure 51: CKE Intensive Environment

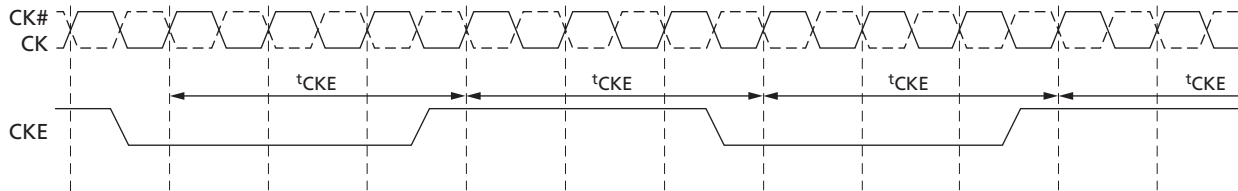
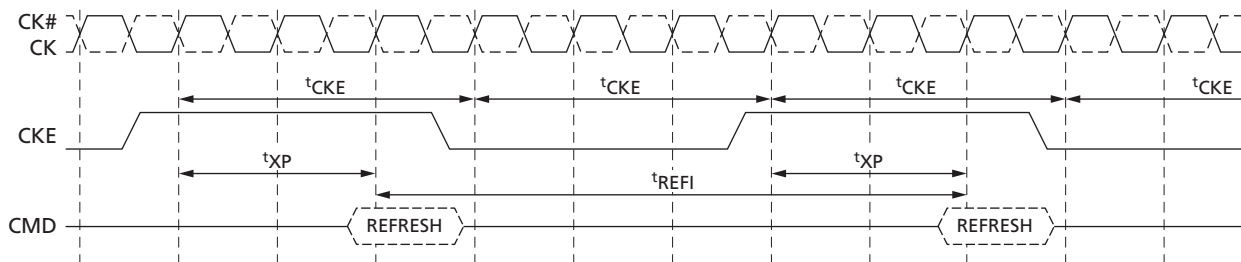

Figure 52: REFRESH-to-REFRESH Timing in CKE Intensive Environments



Note: 1. The pattern shown can repeat over an extended period of time. With this pattern, all AC and DC timing and voltage specifications with temperature and voltage drift are ensured.

Figure 53: READ to Power-Down Entry

BL = 4

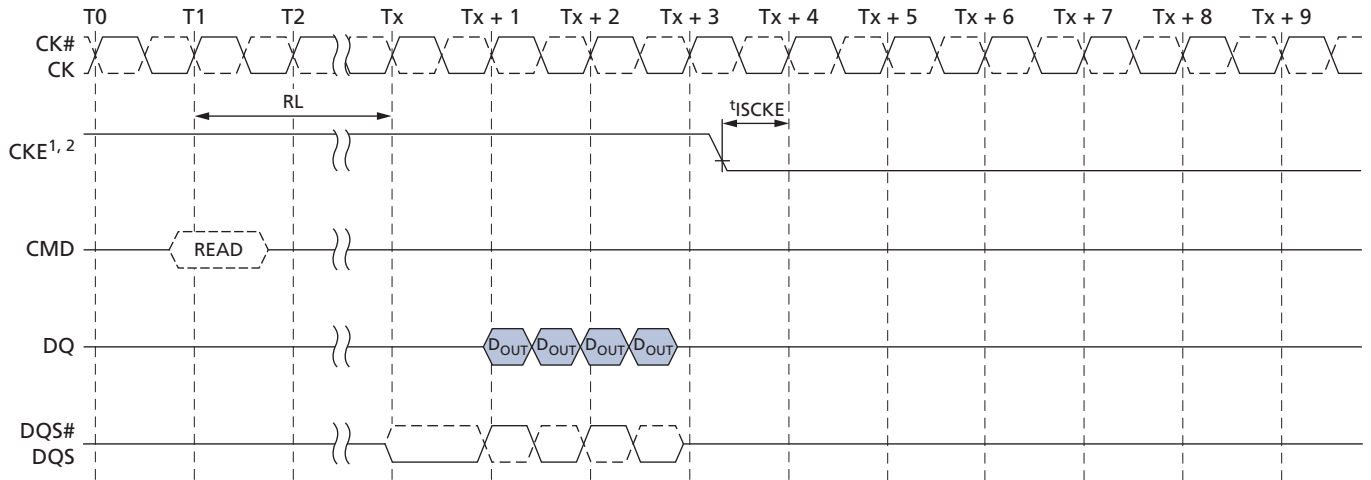

BL = 8

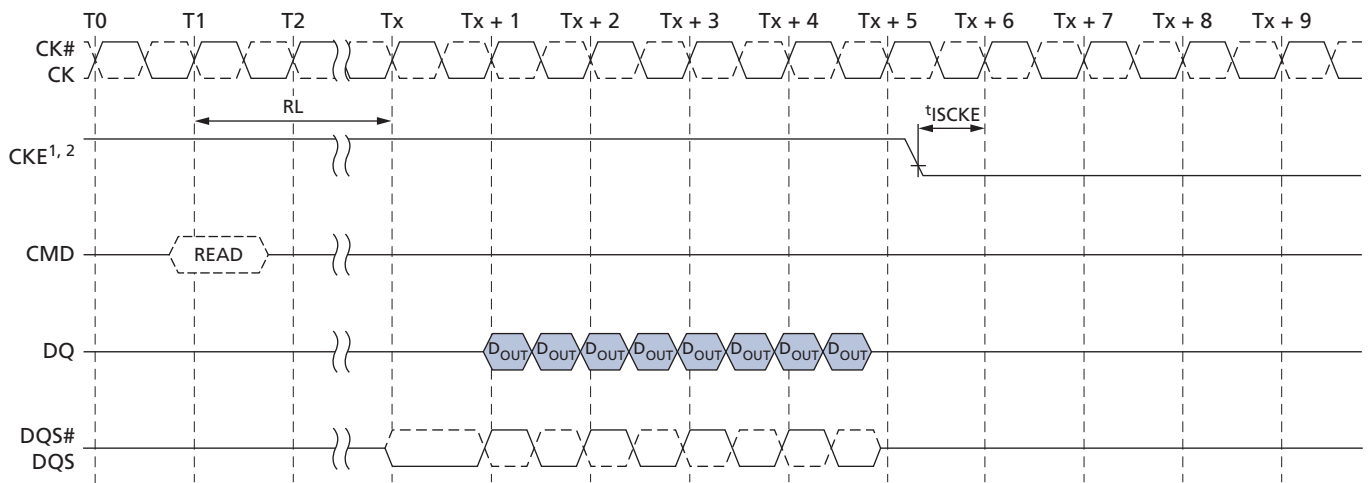

- Notes:
1. CKE must be held HIGH until the end of the burst operation.
 2. CKE can be registered LOW at $(RL + RU(t_{DQSCK(MAX)}/t_{CK}) + BL/2 + 1)$ clock cycles after the clock on which the READ command is registered.

Figure 54: READ with Auto Precharge to Power-Down Entry

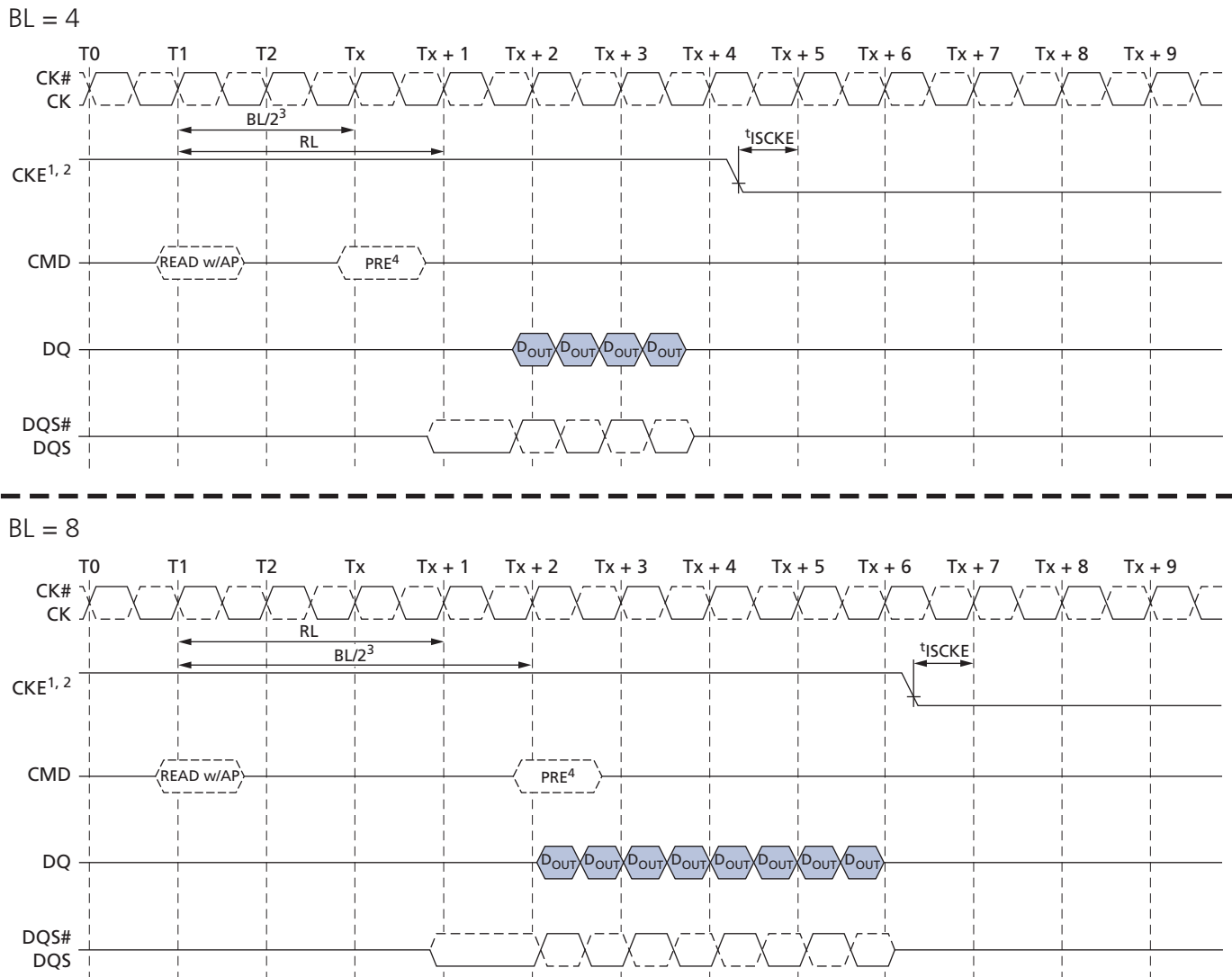

- Notes:
1. CKE must be held HIGH until the end of the burst operation.
 2. CKE can be registered LOW at $(RL + RU(\text{tDQSCK}/\text{tCK}) + BL/2 + 1)$ clock cycles after the clock on which the READ command is registered.
 3. $BL/2$ with $\text{tRTP} = 7.5\text{ns}$ and $\text{tRAS}(\text{MIN})$ is satisfied.
 4. Start internal PRECHARGE.

Figure 55: WRITE to Power-Down Entry

BL = 4

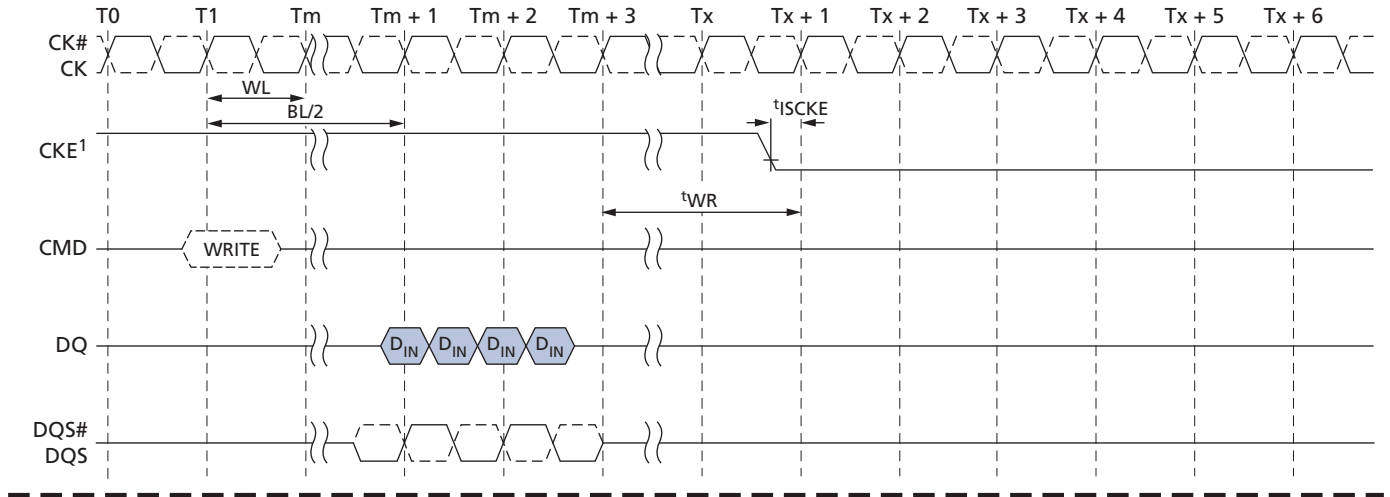

BL = 8

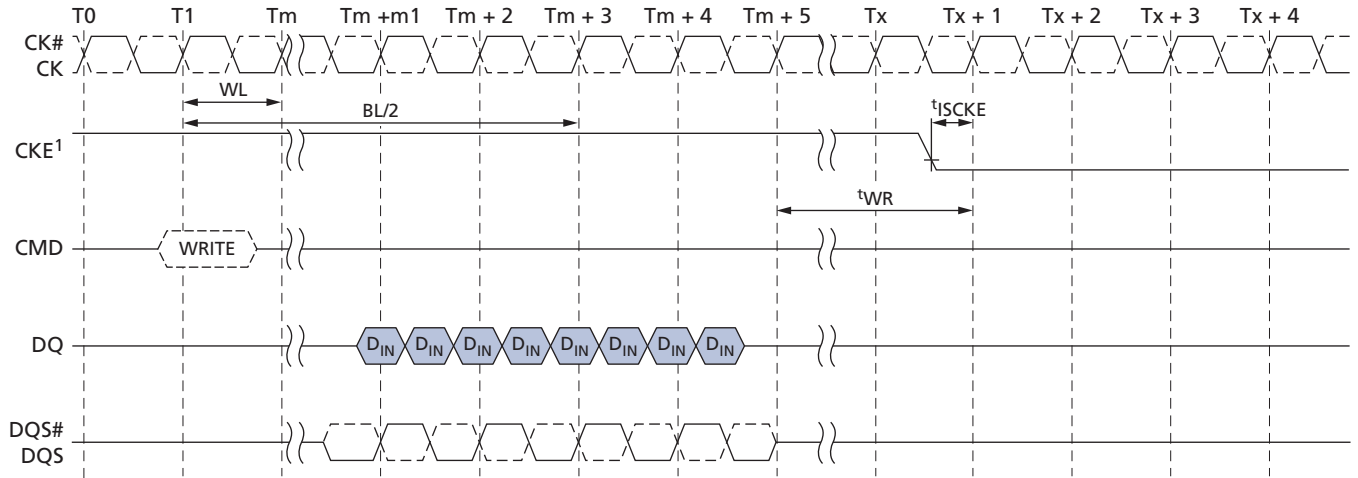

Note: 1. CKE can be registered LOW at $(WL + 1 + BL/2 + RU(t_{WR}/t_{CK}))$ clock cycles after the clock on which the WRITE command is registered.

Figure 56: WRITE with Auto Precharge to Power-Down Entry

BL = 4

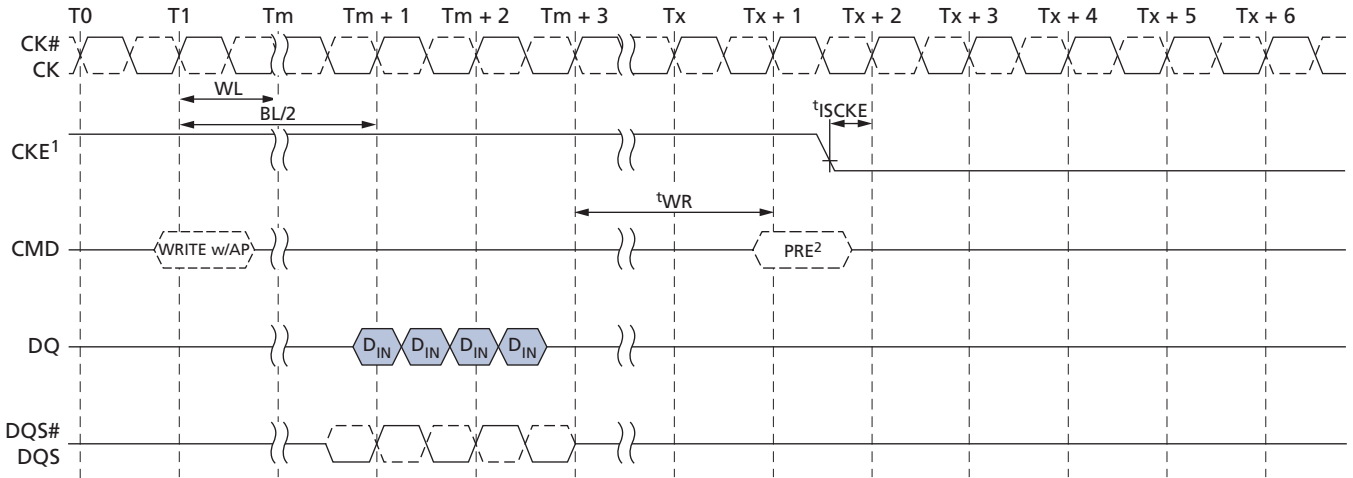

BL = 8

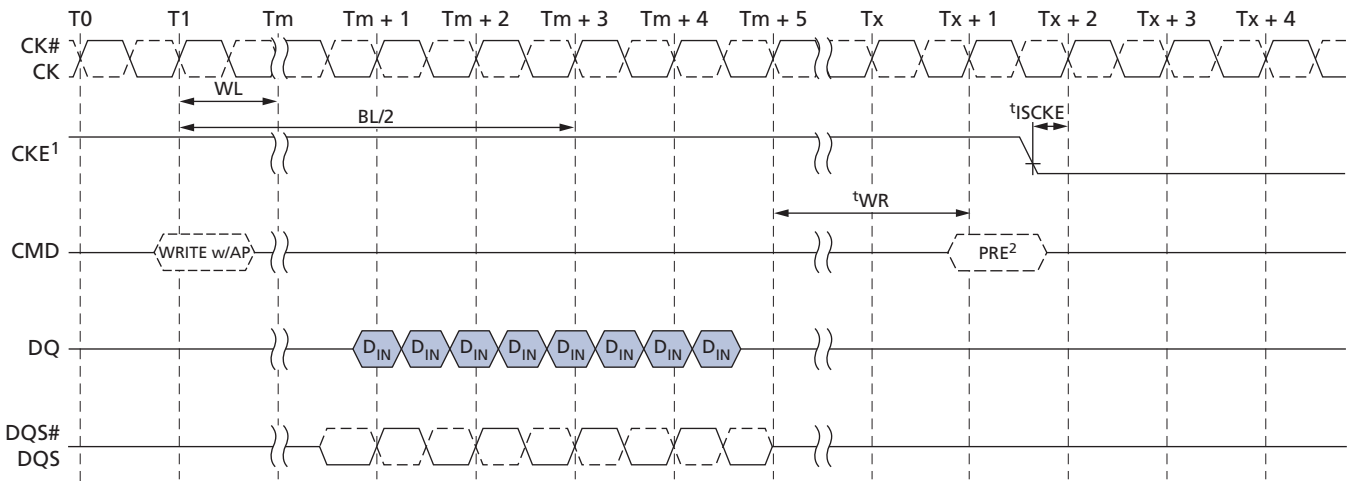

- Notes:
1. CKE can be registered LOW at $(WL + 1 + BL/2 + RU(t_{WR}/t_{CK} + 1))$ clock cycles after the WRITE command is registered.
 2. Start internal PRECHARGE.

Figure 57: REFRESH Command to Power-Down Entry

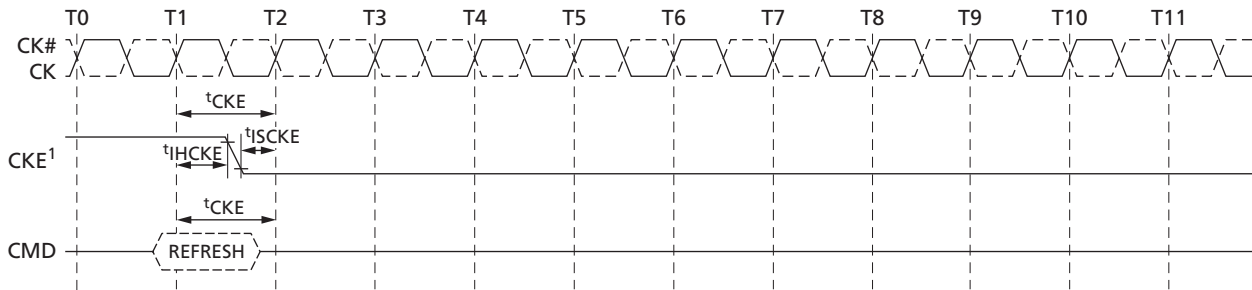

Note: 1. CKE can go LOW t_{IHCKE} after the clock on which the REFRESH command is registered.

Figure 58: ACTIVATE Command to Power-Down Entry

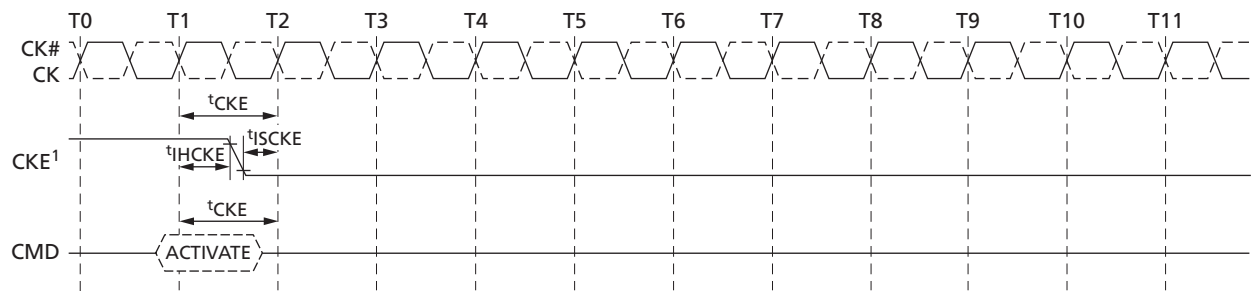

Note: 1. CKE can go LOW at t_{IHCKE} after the clock on which the ACTIVATE command is registered.

Figure 59: PRECHARGE Command to Power-Down Entry

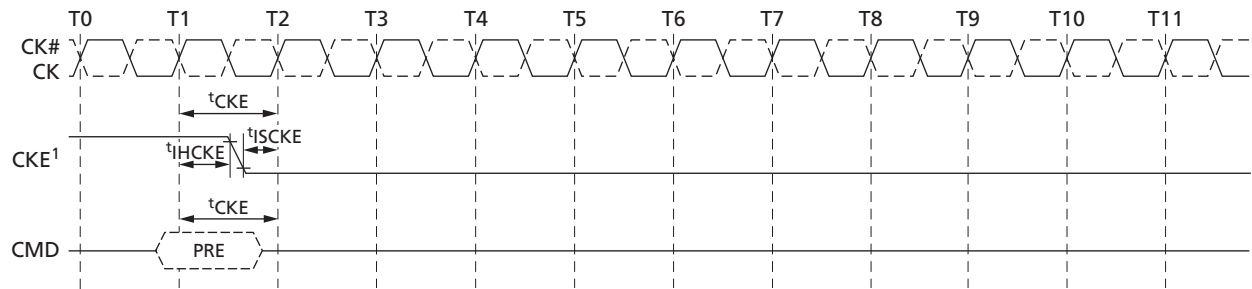

Note: 1. CKE can go LOW t_{IHCKE} after the clock on which the PRECHARGE command is registered.

Figure 60: MRR Command to Power-Down Entry

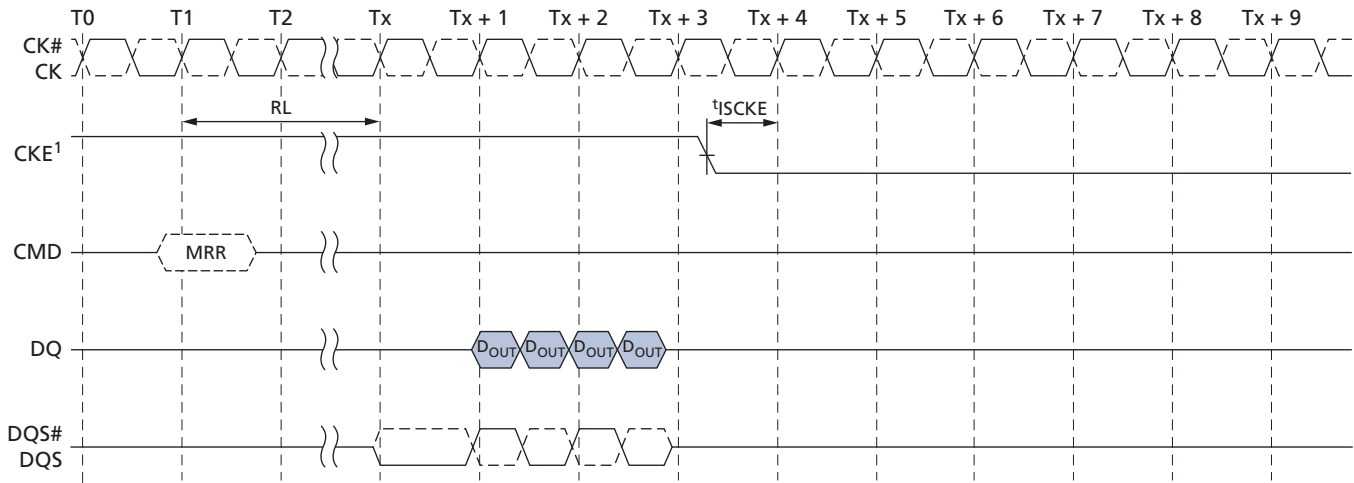

Note: 1. CKE can be registered LOW at $(RL + RU(t_{DQSCK}/t_{CK}) + BL/2 + 1)$ clock cycles after the clock on which the MRR command is registered.

Figure 61: MRW Command to Power-Down Entry

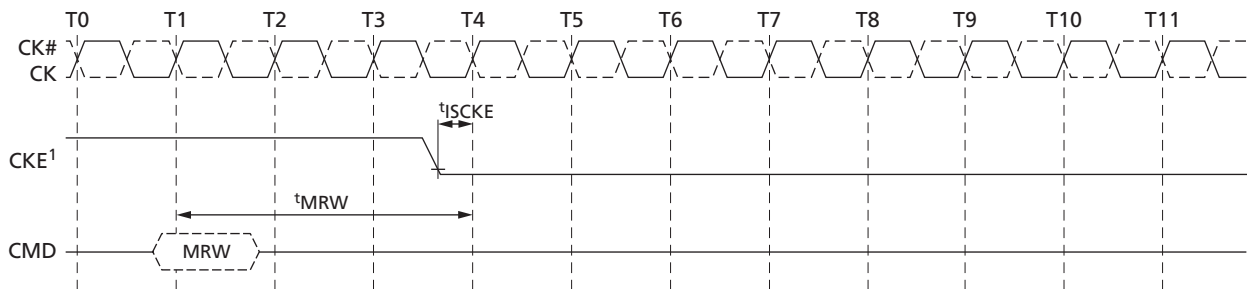

Note: 1. CKE can be registered LOW t_{MRW} after the clock on which the MRW command is registered.

Deep Power-Down

Deep power-down (DPD) is entered when CKE is registered LOW with CS# LOW, CA0 HIGH, CA1 HIGH, and CA2 LOW at the rising edge of the clock. The NOP command must be driven in the clock cycle following power-down entry. CKE must not go LOW while MRR or MRW operations are in progress. CKE can go LOW while other operations such as ACTIVATE, auto precharge, PRECHARGE, or REFRESH are in progress, however, deep power-down I_{DD} specifications will not be applied until those operations complete. The contents of the array will be lost upon entering DPD mode.

In DPD mode, all input buffers except CKE, all output buffers, and the power supply to internal circuitry are disabled within the device. V_{REFDQ} can be at any level between 0 and V_{DDQ} , and V_{REFCA} can be at any level between 0 and V_{DDCA} during DPD. All power supplies (including V_{REF}) must be within the specified limits prior to exiting DPD (see AC and DC Operating Conditions).

To exit DPD, CKE must be HIGH, t_{ISCKE} must be complete, and the clock must be stable. To resume operation, the device must be fully reinitialized using the power-up initialization sequence.

Figure 62: Deep Power-Down Entry and Exit Timing

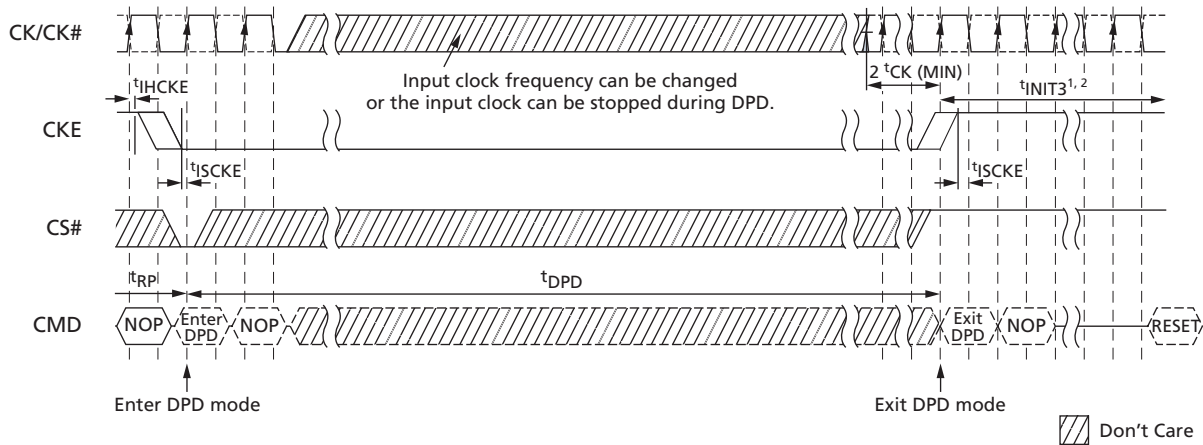

- Notes:
1. The initialization sequence can start at any time after $T_x + 1$.
 2. t_{INIT3} and $T_x + 1$ refer to timings in the initialization sequence. For details, see Mode Register Definition.

Input Clock Frequency Changes and Stop Events

Input Clock Frequency Changes and Clock Stop with CKE LOW

During CKE LOW, Mobile LPDDR2 devices support input clock frequency changes and clock stop under the following conditions:

- Refresh requirements are met
- Only REFab or REFpb commands can be in process
- Any ACTIVATE or PRECHARGE commands have completed prior to changing the frequency
- Related timing conditions, t_{RCD} and t_{RP} , have been met prior to changing the frequency
- The initial clock frequency must be maintained for a minimum of two clock cycles after CKE goes LOW
- The clock satisfies $t_{\text{CH(abs)}}$ and $t_{\text{CL(abs)}}$ for a minimum of two clock cycles prior to CKE going HIGH

For input clock frequency changes, $t_{\text{CK(MIN)}}$ and $t_{\text{CK(MAX)}}$ must be met for each clock cycle.

After the input clock frequency is changed and CKE is held HIGH, additional MRW commands may be required to set the WR, RL, etc. These settings may require adjustment to meet minimum timing requirements at the target clock frequency.

For clock stop, CK is held LOW and CK# is held HIGH.

Input Clock Frequency Changes and Clock Stop with CKE HIGH

During CKE HIGH, LPDDR2 devices support input clock frequency changes and clock stop under the following conditions:

- REFRESH requirements are met
- Any ACTIVATE, READ, WRITE, PRECHARGE, MRW, or MRR commands must have completed, including any associated data bursts, prior to changing the frequency
- Related timing conditions, t_{RCD} , t_{WR} , t_{WRA} , t_{RP} , t_{MRW} , and t_{MRR} , etc., are met
- CS# must be held HIGH
- Only REFab or REFpb commands can be in process

The device is ready for normal operation after the clock satisfies $t_{CH(ABS)}$ and $t_{CL(ABS)}$ for a minimum of $2 \times t_{CK} + t_{XP}$.

For input clock frequency changes, $t_{CK(MIN)}$ and $t_{CK(MAX)}$ must be met for each clock cycle.

After the input clock frequency is changed, additional MRW commands may be required to set the WR, RL, etc. These settings may require adjustment to meet minimum timing requirements at the target clock frequency.

For clock stop, CK is held LOW and CK# is held HIGH.

NO OPERATION Command

The NO OPERATION (NOP) command prevents the device from registering any unwanted commands issued between operations. A NOP command can only be issued at clock cycle N when the CKE level is constant for clock cycle N-1 and clock cycle N. The NOP command has two possible encodings: CS# HIGH at the clock rising edge N; and CS# LOW with CA0, CA1, CA2 HIGH at the clock rising edge N.

The NOP command will not terminate a previous operation that is still in process, such as a READ burst or WRITE burst cycle.

Simplified Bus Interface State Diagram

The state diagram (see Figure 63 (page 83)) provides a simplified illustration of the bus interface, supported state transitions, and the commands that control them. For a complete description of device behavior, use the information provided in the state diagram with the truth tables and timing specifications.

The truth tables describe device behavior and applicable restrictions when considering the actual state of all banks.

Figure 63: Simplified Bus Interface State Diagram

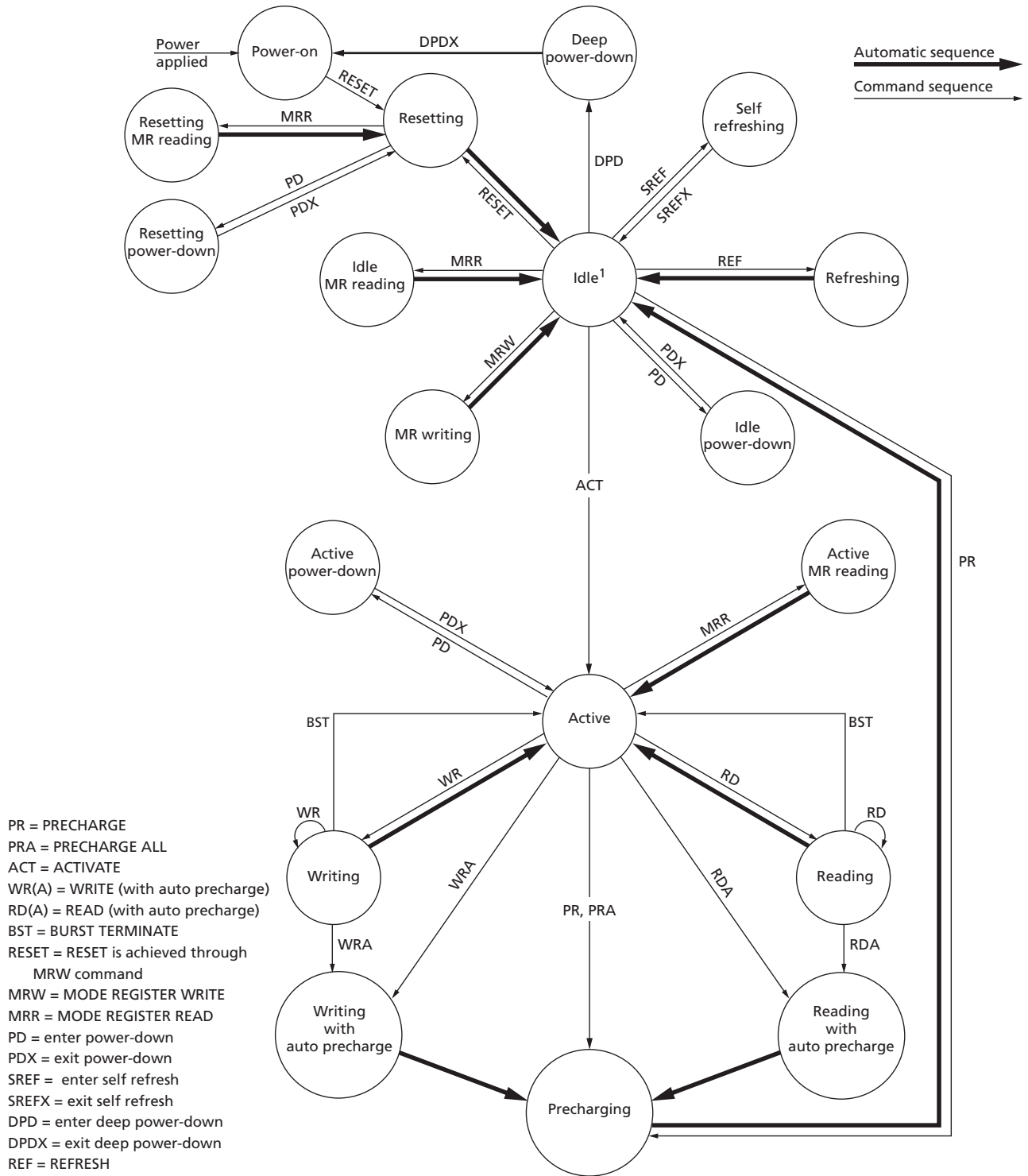

Note: 1. All banks are precharged in the idle state.

Truth Tables

Truth tables provide complementary information to the state diagram. They also clarify device behavior and applicable restrictions when considering the actual state of the banks.

Unspecified operations and timings are illegal. To ensure proper operation after an illegal event, the device must be powered down and then restarted using the specified initialization sequence before normal operation can continue.

Table 48: Command Truth Table

Notes 1–11 apply to all parameters conditions

Command	Command Pins			CA Pins										CK Edge
	CKE		CS#	CA0	CA1	CA2	CA3	CA4	CA5	CA6	CA7	CA8	CA9	
	CK(n-1)	CK(n)												
MRW	H	H	L	L	L	L	L	MA0	MA1	MA2	MA3	MA4	MA5	
	H	H	X	MA6	MA7	OP0	OP1	OP2	OP3	OP4	OP5	OP6	OP7	
MRR	H	H	L	L	L	L	H	MA0	MA1	MA2	MA3	MA4	MA5	
	H	H	X	MA6	MA7	X								
REFRESH (per bank)	H	H	L	L	L	H	L	X						
	H	H	X	X										
REFRESH (all banks)	H	H	L	L	L	H	H	X						
	H	H	X	X										
Enter self refresh	H	L	L	L	L	H	X							
	X	L	X	X										
ACTIVATE (bank)	H	H	L	L	H	R8	R9	R10	R11	R12	BA0	BA1	BA2	
	H	H	X	R0	R1	R2	R3	R4	R5	R6	R7	R13	R14	
WRITE (bank)	H	H	L	H	L	L	RFU	RFU	C1	C2	BA0	BA1	BA2	
	H	H	X	AP	C3	C4	C5	C6	C7	C8	C9	C10	C11	
READ (bank)	H	H	L	H	L	H	RFU	RFU	C1	C2	BA0	BA1	BA2	
	H	H	X	AP	C3	C4	C5	C6	C7	C8	C9	C10	C11	
PRECHARGE (bank)	H	H	L	H	H	L	H	AB	X	X	BA0	BA1	BA2	
	H	H	X	X										
BST	H	H	L	H	H	L	L	X						
	H	H	X	X										
Enter DPD	H	L	L	H	H	L	X							
	X	L	X	X										
NOP	H	H	L	H	H	H	X							
	H	H	X	X										
Maintain PD, SREF, DPD, (NOP)	L	L	L	H	H	H	X							
	L	L	X	X										

Table 48: Command Truth Table (Continued)

Notes 1–11 apply to all parameters conditions

Command	Command Pins			CA Pins									CK Edge	
	CKE		CS#	CA0	CA1	CA2	CA3	CA4	CA5	CA6	CA7	CA8		CA9
	CK(n-1)	CK(n)												
NOP	H	H	H	X										
	H	H	X	X										
Maintain PD, SREF, DPD, (NOP)	L	L	H	X										
	L	L	X	X										
Enter power-down	H	L	H	X										
	X	L	X	X										
Exit PD, SREF, DPD	L	H	H	X										
	X	H	X	X										

- Notes:
- All commands are defined by the current state of CS#, CA0, CA1, CA2, CA3, and CKE at the rising edge of the clock.
 - Bank addresses (BA) determine which bank will be operated upon.
 - AP HIGH during a READ or WRITE command indicates that an auto precharge will occur to the bank associated with the READ or WRITE command.
 - X indicates a “Don’t Care” state, with a defined logic level, either HIGH (H) or LOW (L).
 - Self refresh exit and DPD exit are asynchronous.
 - V_{REF} must be between 0 and V_{DDQ} during self refresh and DPD operation.
 - CA_{xr} refers to command/address bit “x” on the rising edge of clock.
 - CA_{xf} refers to command/address bit “x” on the falling edge of clock.
 - CS# and CKE are sampled on the rising edge of the clock.
 - Per-bank refresh is only supported in devices with eight banks.
 - The least-significant column address C0 is not transmitted on the CA bus, and is inferred to be zero.

Table 49: CKE Truth Table

Notes 1–5 apply to all parameters and conditions; L = LOW, H = HIGH, X = “Don’t Care”

Current State	CKEn-1	CKEn	CS#	Command n	Operation n	Next State	Notes
Active power-down	L	L	X	X	Maintain active power-down	Active power-down	
	L	H	H	NOP	Exit active power-down	Active	6, 7
Idle power-down	L	L	X	X	Maintain idle power-down	Idle power-down	
	L	H	H	NOP	Exit idle power-down	Idle	6, 7
Resetting idle power-down	L	L	X	X	Maintain resetting power-down	Resetting power-down	
	L	H	H	NOP	Exit resetting power-down	Idle or resetting	6, 7, 8

Table 49: CKE Truth Table (Continued)

Notes 1–5 apply to all parameters and conditions; L = LOW, H = HIGH, X = “Don’t Care”

Current State	CKEn-1	CKEn	CS#	Command <i>n</i>	Operation <i>n</i>	Next State	Notes	
Deep power-down	L	L	X	X	Maintain deep power-down	Deep power-down		
	L	H	H	NOP	Exit deep power-down	Power-on	9	
Self refresh	L	L	X	X	Maintain self refresh	Self refresh		
	L	H	H	NOP	Exit self refresh	Idle	10, 11	
Bank(s) active	H	L	H	NOP	Enter active power-down	Active power-down		
All banks idle	H	L	H	NOP	Enter idle power-down	Idle power-down		
	H	L	L	Enter self refresh	Enter self refresh	Self refresh		
	H	L	L	DPD	Enter deep power-down	Deep power-down		
Resetting	H	L	H	NOP	Enter resetting power-down	Resetting power-down		
Other states	H	H	Refer to the command truth table					

- Notes:
1. Current state = the state of the device immediately prior to the clock rising edge *n*.
 2. All states and sequences not shown are illegal or reserved unless explicitly described elsewhere in this document.
 3. CKEn = the logic state of CKE at clock rising edge *n*; CKEn-1 was the state of CKE at the previous clock edge.
 4. CS# = the logic state of CS# at the clock rising edge *n*.
 5. Command *n* = the command registered at clock edge *n*, and operation *n* is a result of command *n*.
 6. Power-down exit time (^tXP) must elapse before any command other than NOP is issued.
 7. The clock must toggle at least twice prior to the ^tXP period.
 8. Upon exiting the resetting power-down state, the device will return to the idle state if ^tINIT5 has expired.
 9. The DPD exit procedure must be followed as described in Deep Power Down.
 10. Self refresh exit time (^tXSR) must elapse before any command other than NOP is issued.
 11. The clock must toggle at least twice prior to the ^tXSR time.

Table 50: Current State Bank *n* to Command to Bank *n* Truth Table

Notes 1–5 apply to all parameters and conditions

Current State	Command	Operation	Next State	Notes
Any	NOP	Continue previous operation	Current state	

Table 50: Current State Bank *n* to Command to Bank *n* Truth Table (Continued)

Notes 1–5 apply to all parameters and conditions

Current State	Command	Operation	Next State	Notes
Idle	ACTIVATE	Select and activate row	Active	
	Refresh (per bank)	Begin to refresh	Refreshing (per bank)	6
	Refresh (all banks)	Begin to refresh	Refreshing (all banks)	7
	MRW	Load value to mode register	MR writing	7
	MRR	Read value from mode register	Idle, MR reading	
	RESET	Begin device auto initialization	Resetting	7, 8
	PRECHARGE	Deactivate row(s) in bank or banks	Precharging	9, 10
Row active	READ	Select column and start read burst	Reading	
	WRITE	Select column and start write burst	Writing	
	MRR	Read value from mode register	Active MR reading	
	PRECHARGE	Deactivate row(s) in bank or banks	Precharging	9
Reading	READ	Select column and start new read burst	Reading	11, 12
	WRITE	Select column and start write burst	Writing	11, 12, 13
	BST	Read burst terminate	Active	14
Writing	WRITE	Select column and start new write burst	Writing	11, 12
	READ	Select column and start read burst	Reading	11, 12, 15
	BST	Write burst terminate	Active	14
Power-on	MRW RESET	Begin device auto initialization	Resetting	7, 9
Resetting	MRR	Read value from mode register	Resetting MR reading	

- Notes:
1. Values in this table apply when both $CKEn -1$ and $CKEn$ are HIGH, and after t^XSR or t^XP has been met, if the previous state was power-down.
 2. All states and sequences not shown are illegal or reserved.
 3. Current state definitions:

Idle: The bank or banks have been precharged, and t^RP has been met.

Active: A row in the bank has been activated, and t^RCD has been met. No data bursts or accesses and no register accesses are in progress.

Reading: A READ burst has been initiated with auto precharge disabled and has not yet terminated or been terminated.

Writing: A WRITE burst has been initiated with auto precharge disabled and has not yet terminated or been terminated.

4. The states listed below must not be interrupted by a command issued to the same bank. NOP commands or supported commands to the other bank must be issued on any clock edge occurring during these states. Supported commands to the other banks are determined by that bank's current state, and the definitions given in the following table.

Precharge: Starts with registration of a PRECHARGE command and ends when t^RP is met. After t^RP is met, the bank is in the idle state.

Row activate: Starts with registration of an ACTIVATE command and ends when t^RCD is met. After t^RCD is met, the bank is in the active state.

- READ with AP enabled: Starts with registration of a READ command with auto pre-charge enabled and ends when t^{RP} is met. After t^{RP} is met, the bank is in the idle state.
- WRITE with AP enabled: Starts with registration of a WRITE command with auto pre-charge enabled and ends when t^{RP} is met. After t^{RP} is met, the bank is in the idle state.
5. The states listed below must not be interrupted by any executable command. NOP commands must be applied to each rising clock edge during these states.
- Refresh (per bank): Starts with registration of a REFRESH (per bank) command and ends when t^{RFCpb} is met. After t^{RFCpb} is met, the bank is in the idle state.
- Refresh (all banks): Starts with registration of a REFRESH (all banks) command and ends when t^{RFCab} is met. After t^{RFCab} is met, the device is in the all banks idle state.
- Idle MR reading: Starts with registration of the MRR command and ends when t^{MRR} is met. After t^{MRR} is met, the device is in the all banks idle state.
- Resetting MR reading: Starts with registration of the MRR command and ends when t^{MRR} is met. After t^{MRR} is met, the device is in the all banks idle state.
- Active MR reading: Starts with registration of the MRR command and ends when t^{MRR} is met. After t^{MRR} is met, the bank is in the active state.
- MR writing: Starts with registration of the MRW command and ends when t^{MRW} is met. After t^{MRW} is met, the device is in the all banks idle state.
- Precharging all: Starts with registration of a PRECHARGE ALL command and ends when t^{RP} is met. After t^{RP} is met, the device is in the all banks idle state.
6. Bank-specific; requires that the bank is idle and no bursts are in progress.
7. Not bank-specific; requires that all banks are idle and no bursts are in progress.
8. Not bank-specific.
9. This command may or may not be bank specific. If all banks are being precharged, they must be in a valid state for precharging.
10. If a PRECHARGE command is issued to a bank in the idle state, t^{RP} still applies.
11. A command other than NOP should not be issued to the same bank while a burst READ or burst WRITE with auto precharge is enabled.
12. The new READ or WRITE command could be auto precharge enabled or auto precharge disabled.
13. A WRITE command can be issued after the completion of the READ burst; otherwise, a BST must be issued to end the READ prior to asserting a WRITE command.
14. Not bank-specific. The BST command affects the most recent READ/WRITE burst started by the most recent READ/WRITE command, regardless of bank.
15. A READ command can be issued after completion of the WRITE burst; otherwise, a BST must be used to end the WRITE prior to asserting another READ command.

Table 51: Current State Bank n to Command to Bank m Truth Table

Notes 1–6 apply to all parameters and conditions

Current State of Bank n	Command to Bank m	Operation	Next State for Bank m	Notes
Any	NOP	Continue previous operation	Current state of bank m	
Idle	Any	Any command supported to bank m	–	7

Table 51: Current State Bank *n* to Command to Bank *m* Truth Table (Continued)

Notes 1–6 apply to all parameters and conditions

Current State of Bank <i>n</i>	Command to Bank <i>m</i>	Operation	Next State for Bank <i>m</i>	Notes
Row activating, active, or pre-charging	ACTIVATE	Select and activate row in bank <i>m</i>	Active	8
	READ	Select column and start READ burst from bank <i>m</i>	Reading	9
	WRITE	Select column and start WRITE burst to bank <i>m</i>	Writing	9
	PRECHARGE	Deactivate row(s) in bank or banks	Precharging	10
	MRR	READ value from mode register	Idle MR reading or active MR reading	11, 12, 13
	BST	READ or WRITE burst terminates an on-going READ/WRITE from/to bank <i>m</i>	Active	7
Reading (auto precharge disabled)	READ	Select column and start READ burst from bank <i>m</i>	Reading	9
	WRITE	Select column and start WRITE burst to bank <i>m</i>	Writing	9, 14
	ACTIVATE	Select and activate row in bank <i>m</i>	Active	
	PRECHARGE	Deactivate row(s) in bank or banks	Precharging	10
Writing (auto precharge disabled)	READ	Select column and start READ burst from bank <i>m</i>	Reading	9, 15
	WRITE	Select column and start WRITE burst to bank <i>m</i>	Writing	9
	ACTIVATE	Select and activate row in bank <i>m</i>	Active	
	PRECHARGE	Deactivate row(s) in bank or banks	Precharging	10
Reading with auto precharge	READ	Select column and start READ burst from bank <i>m</i>	Reading	9, 16
	WRITE	Select column and start WRITE burst to bank <i>m</i>	Writing	9, 14, 16
	ACTIVATE	Select and activate row in bank <i>m</i>	Active	
	PRECHARGE	Deactivate row(s) in bank or banks	Precharging	10
Writing with auto precharge	READ	Select column and start READ burst from bank <i>m</i>	Reading	9, 15, 16
	WRITE	Select column and start WRITE burst to bank <i>m</i>	Writing	9, 16
	ACTIVATE	Select and activate row in bank <i>m</i>	Active	
	PRECHARGE	Deactivate row(s) in bank or banks	Precharging	10
Power-on	MRW RESET	Begin device auto initialization	Resetting	17, 18
Resetting	MRR	Read value from mode register	Resetting MR reading	

- Notes: 1. This table applies when: the previous state was self refresh or power-down; after ^tXSR or ^tXP has been met; and both CKEn -1 and CKEn are HIGH.
2. All states and sequences not shown are illegal or reserved.

3. Current state definitions:

Idle: The bank has been precharged and t_{RP} has been met.

Active: A row in the bank has been activated, t_{RCD} has been met, no data bursts or accesses and no register accesses are in progress.

Read: A READ burst has been initiated with auto precharge disabled and the READ has not yet terminated or been terminated.

Write: A WRITE burst has been initiated with auto precharge disabled and the WRITE has not yet terminated or been terminated.

4. Refresh, self refresh, and MRW commands can only be issued when all banks are idle.
5. A BST command cannot be issued to another bank; it applies only to the bank represented by the current state.
6. The states listed below must not be interrupted by any executable command. NOP commands must be applied during each clock cycle while in these states:

Idle MRR: Starts with registration of the MRR command and ends when t_{MRR} has been met. After t_{MRR} is met, the device is in the all banks idle state.

Reset MRR: Starts with registration of the MRR command and ends when t_{MRR} has been met. After t_{MRR} is met, the device is in the all banks idle state.

Active MRR: Starts with registration of the MRR command and ends when t_{MRR} has been met. After t_{MRR} is met, the bank is in the active state.

MRW: Starts with registration of the MRW command and ends when t_{MRW} has been met. After t_{MRW} is met, the device is in the all banks idle state.

7. BST is supported only if a READ or WRITE burst is ongoing.
8. t_{RRD} must be met between the ACTIVATE command to bank n and any subsequent ACTIVATE command to bank m .
9. READs or WRITEs listed in the command column include READs and WRITEs with or without auto precharge enabled.
10. This command may or may not be bank-specific. If all banks are being precharged, they must be in a valid state for precharging.
11. MRR is supported in the row-activating state.
12. MRR is supported in the precharging state.
13. The next state for bank m depends on the current state of bank m (idle, row-activating, precharging, or active).
14. A WRITE command can be issued after the completion of the READ burst; otherwise a BST must be issued to end the READ prior to asserting a WRITE command.
15. A READ command can be issued after the completion of the WRITE burst; otherwise, a BST must be issued to end the WRITE prior to asserting another READ command.
16. A READ with auto precharge enabled or a WRITE with auto precharge enabled can be followed by any valid command to other banks provided that the timing restrictions in the PRECHARGE and Auto Precharge Clarification table are met.
17. Not bank-specific; requires that all banks are idle and no bursts are in progress.
18. RESET command is achieved through MODE REGISTER WRITE command.

Table 52: DM Truth Table

Functional Name	DM	DQ	Notes
Write enable	L	Valid	1
Write inhibit	H	X	1

Note: 1. Used to mask write data, and is provided simultaneously with the corresponding input data.

Electrical Specifications

Absolute Maximum Ratings

Stresses greater than those listed below may cause permanent damage to the device. This is a stress rating only, and functional operation of the device at these or any other conditions outside those indicated in the operational sections of this document is not implied. Exposure to absolute maximum rating conditions for extended periods may adversely affect reliability.

Table 53: Absolute Maximum DC Ratings

Parameter	Symbol	Min	Max	Unit	Notes
V _{DD1} supply voltage relative to V _{SS}	V _{DD1}	-0.4	+2.3	V	1
V _{DD2} supply voltage relative to V _{SS}	V _{DD2} (1.2V)	-0.4	+1.6	V	1
V _{DDCA} supply voltage relative to V _{SSCA}	V _{DDCA}	-0.4	+1.6	V	1, 2
V _{DDQ} supply voltage relative to V _{SSQ}	V _{DDQ}	-0.4	+1.6	V	1, 3
Voltage on any ball relative to V _{SS}	V _{IN} , V _{OUT}	-0.4	+1.6	V	
Storage temperature	T _{STG}	-55	+125	°C	4

- Notes:
- See 1. Voltage Ramp under Power-Up (page 20).
 - V_{REFCA} 0.6 ≤ V_{DDCA}; however, V_{REFCA} may be ≥ V_{DDCA} provided that V_{REFCA} ≤ 300mV.
 - V_{REFDQ} 0.6 ≤ V_{DDQ}; however, V_{REFDQ} may be ≥ V_{DDQ} provided that V_{REFDQ} ≤ 300mV.
 - Storage temperature is the case surface temperature on the center/top side of the device. For measurement conditions, refer to the JESD51-2 standard.

Input/Output Capacitance

Table 54: Input/Output Capacitance

Note 1 applies to all parameters and conditions

Parameter	Symbol	LPDDR2 1066-466		LPDDR2 400-200		Unit	Notes
		MIN	MAX	MIN	MAX		
Input capacitance, CK and CK#	C _{CK}	1.0	2.0	1.0	2.0	pF	2, 3
Input capacitance delta, CK and CK#	C _{DCK}	0	0.20	0	0.25	pF	2, 3, 4
Input capacitance, all other input-only pins	C _I	1.0	2.0	1.0	2.0	pF	2, 3, 5
Input capacitance delta, all other input-only pins	C _{DI}	-0.40	+0.40	-0.50	+0.50	pF	2, 3, 6
Input/output capacitance, DQ, DM, DQS, DQS#	C _{IO}	1.25	2.5	1.25	2.5	pF	2, 3, 7, 8
Input/output capacitance delta, DQS, DQS#	C _{DDQS}	0	0.25	0	0.30	pF	2, 3, 8, 9
Input/output capacitance delta, DQ, DM	C _{DIO}	-0.5	+0.5	-0.6	+0.6	pF	2, 3, 8, 10



512Mb: x32 Automotive Mobile LPDDR2 SDRAM Electrical Specifications – I_{DD} Specifications and Conditions

Table 54: Input/Output Capacitance (Continued)

Note 1 applies to all parameters and conditions

Parameter	Symbol	LPDDR2 1066-466		LPDDR2 400-200		Unit	Notes
		MIN	MAX	MIN	MAX		
Input/output capacitance ZQ	C _{ZQ}	0	2.5	0	2.5	pF	2, 3, 11

- Notes:
1. T_C –40°C to +105°C; V_{DDQ} = 1.14–1.3V; V_{DDCA} = 1.14–1.3V; V_{DD1} = 1.7–1.95V; V_{DD2} = 1.14–1.3V.
 2. This parameter applies to die devices only (does not include package capacitance).
 3. This parameter is not subject to production testing. It is verified by design and characterization. The capacitance is measured according to JEP147 (procedure for measuring input capacitance using a vector network analyzer), with V_{DD1}, V_{DD2}, V_{DDQ}, V_{SS}, V_{SSCA}, and V_{SSQ} applied; all other pins are left floating.
 4. Absolute value of C_{CK} - C_{CK#}.
 5. C_I applies to CS#, CKE, and CA[9:0].
 6. C_{DI} = C_I - 0.5 × (C_{CK} + C_{CK#}).
 7. DM loading matches DQ and DQS.
 8. MR3 I/O configuration drive strength OP[3:0] = 0001b (34.3 ohm typical).
 9. Absolute value of C_{DQS} and C_{DQS#}.
 10. C_{DIO} = C_{IO} - 0.5 × (C_{DQS} + C_{DQS#}) in byte-lane.
 11. Maximum external load capacitance on ZQ pin: 5pF.

Electrical Specifications – I_{DD} Specifications and Conditions

The following definitions and conditions are used in the I_{DD} measurement tables unless stated otherwise:

- LOW: V_{IN} ≤ V_{IL(DC)max}
- HIGH: V_{IN} ≥ V_{IH(DC)min}
- STABLE: Inputs are stable at a HIGH or LOW level
- SWITCHING: See the following three tables

Table 55: Switching for CA Input Signals

Notes 1–3 apply to all parameters and conditions

	CK Rising/ CK#Falling	CK Falling/ CK# Rising	CK Rising/ CK#Falling	CK Falling/ CK# Rising	CK Rising/ CK#Falling	CK Falling/ CK# Rising	CK Rising/ CK#Falling	CK Falling/ CK# Rising
Cycle	N		N + 1		N + 2		N + 3	
CS#	HIGH		HIGH		HIGH		HIGH	
CA0	H	L	L	L	L	H	H	H
CA1	H	H	H	L	L	L	L	H
CA2	H	L	L	L	L	H	H	H
CA3	H	H	H	L	L	L	L	H
CA4	H	L	L	L	L	H	H	H
CA5	H	H	H	L	L	L	L	H
CA6	H	L	L	L	L	H	H	H
CA7	H	H	H	L	L	L	L	H

Table 55: Switching for CA Input Signals (Continued)

Notes 1–3 apply to all parameters and conditions

	CK Rising/ CK#Falling	CK Falling/ CK# Rising	CK Rising/ CK#Falling	CK Falling/ CK# Rising	CK Rising/ CK#Falling	CK Falling/ CK# Rising	CK Rising/ CK#Falling	CK Falling/ CK# Rising
CA8	H	L	L	L	L	H	H	H
CA9	H	H	H	L	L	L	L	H

- Notes: 1. CS# must always be driven HIGH.
 2. For each clock cycle, 50% of the CA bus is changing between HIGH and LOW.
 3. The noted pattern (N, N + 1, N + 2, N + 3...) is used continuously during I_{DD} measurement for I_{DD} values that require switching on the CA bus.

Table 56: Switching for I_{DD4R}

Clock	CKE	CS#	Clock Cycle Number	Command	CA[2:0]	CA[9:3]	All DQ
Rising	H	L	N	Read_Rising	HLH	LHLHLHL	L
Falling	H	L	N	Read_Falling	LLL	LLLLLLL	L
Rising	H	H	N + 1	NOP	LLL	LLLLLLL	H
Falling	H	H	N + 1	NOP	HLH	LHLHLHL	L
Rising	H	L	N + 2	Read_Rising	HLH	LHLHLHL	H
Falling	H	L	N + 2	Read_Falling	LLL	HHHHHHH	H
Rising	H	H	N + 3	NOP	LLL	HHHHHHH	H
Falling	H	H	N + 3	NOP	HLH	LHLHLHL	L

- Notes: 1. Data strobe (DQS) is changing between HIGH and LOW with every clock cycle.
 2. The noted pattern (N, N + 1...) is used continuously during I_{DD} measurement for I_{DD4R}.

Table 57: Switching for I_{DD4W}

Clock	CKE	CS#	Clock Cycle Number	Command	CA[2:0]	CA[9:3]	All DQ
Rising	H	L	N	Write_Rising	LLH	LHLHLHL	L
Falling	H	L	N	Write_Falling	LLL	LLLLLLL	L
Rising	H	H	N + 1	NOP	LLL	LLLLLLL	H
Falling	H	H	N + 1	NOP	HLH	LHLHLHL	L
Rising	H	L	N + 2	Write_Rising	LLH	LHLHLHL	H
Falling	H	L	N + 2	Write_Falling	LLL	HHHHHHH	H
Rising	H	H	N + 3	NOP	LLL	HHHHHHH	H
Falling	H	H	N + 3	NOP	HLH	LHLHLHL	L

- Notes: 1. Data strobe (DQS) is changing between HIGH and LOW with every clock cycle.
 2. Data masking (DM) must always be driven LOW.
 3. The noted pattern (N, N + 1...) is used continuously during I_{DD} measurement for I_{DD4W}.



512Mb: x32 Automotive Mobile LPDDR2 SDRAM Electrical Specifications – I_{DD} Specifications and Conditions

Table 58: I_{DD} Specification Parameters and Operating Conditions

Notes 1–3 apply to all parameters and conditions

Parameter/Condition	Symbol	Power Supply	Notes
Operating one bank active-precharge current (SDRAM): ^t CK = ^t CK _{min} ; ^t RC = ^t RC _{min} ; CKE is HIGH; CS# is HIGH between valid commands; CA bus inputs are switching; Data bus inputs are stable	I _{DD01}	V _{DD1}	
	I _{DD02}	V _{DD2}	
	I _{DD0in}	V _{DDCA} , V _{DDQ}	4
Idle power-down standby current: ^t CK = ^t CK _{min} ; CKE is LOW; CS# is HIGH; All banks are idle; CA bus inputs are switching; Data bus inputs are stable	I _{DD2P1}	V _{DD1}	
	I _{DD2P2}	V _{DD2}	
	I _{DD2P,in}	V _{DDCA} , V _{DDQ}	4
Idle power-down standby current with clock stop: CK = LOW, CK# = HIGH; CKE is LOW; CS# is HIGH; All banks are idle; CA bus inputs are stable; Data bus inputs are stable	I _{DD2PS1}	V _{DD1}	
	I _{DD2PS2}	V _{DD2}	
	I _{DD2PS,in}	V _{DDCA} , V _{DDQ}	4
Idle non-power-down standby current: ^t CK = ^t CK _{min} ; CKE is HIGH; CS# is HIGH; All banks are idle; CA bus inputs are switching; Data bus inputs are stable	I _{DD2N1}	V _{DD1}	
	I _{DD2N2}	V _{DD2}	
	I _{DD2N,in}	V _{DDCA} , V _{DDQ}	4
Idle non-power-down standby current with clock stopped: CK = LOW; CK# = HIGH; CKE is HIGH; CS# is HIGH; All banks are idle; CA bus inputs are stable; Data bus inputs are stable	I _{DD2NS1}	V _{DD1}	
	I _{DD2NS2}	V _{DD2}	
	I _{DD2NS,in}	V _{DDCA} , V _{DDQ}	4
Active power-down standby current: ^t CK = ^t CK _{min} ; CKE is LOW; CS# is HIGH; One bank is active; CA bus inputs are switching; Data bus inputs are stable	I _{DD3P1}	V _{DD1}	
	I _{DD3P2}	V _{DD2}	
	I _{DD3P,in}	V _{DDCA} , V _{DDQ}	4
Active power-down standby current with clock stop: CK = LOW, CK# = HIGH; CKE is LOW; CS# is HIGH; One bank is active; CA bus inputs are stable; Data bus inputs are stable	I _{DD3PS1}	V _{DD1}	
	I _{DD3PS2}	V _{DD2}	
	I _{DD3PS,in}	V _{DDCA} , V _{DDQ}	4
Active non-power-down standby current: ^t CK = ^t CK _{min} ; CKE is HIGH; CS# is HIGH; One bank is active; CA bus inputs are switching; Data bus inputs are stable	I _{DD3N1}	V _{DD1}	
	I _{DD3N2}	V _{DD2}	
	I _{DD3N,in}	V _{DDCA} , V _{DDQ}	4
Active non-power-down standby current with clock stopped: CK = LOW, CK# = HIGH CKE is HIGH; CS# is HIGH; One bank is active; CA bus inputs are stable; Data bus inputs are stable	I _{DD3NS1}	V _{DD1}	
	I _{DD3NS2}	V _{DD2}	
	I _{DD3NS,in}	V _{DDCA} , V _{DDQ}	4
Operating burst READ current: ^t CK = ^t CK _{min} ; CS# is HIGH between valid commands; One bank is active; BL = 4; RL = RL (MIN); CA bus inputs are switching; 50% data change each burst transfer	I _{DD4R1}	V _{DD1}	
	I _{DD4R2}	V _{DD2}	
	I _{DD4R,in}	V _{DDCA}	
	I _{DD4RQ}	V _{DDQ}	5
Operating burst WRITE current: ^t CK = ^t CK _{min} ; CS# is HIGH between valid commands; One bank is active; BL = 4; WL = WL _{min} ; CA bus inputs are switching; 50% data change each burst transfer	I _{DD4W1}	V _{DD1}	
	I _{DD4W2}	V _{DD2}	
	I _{DD4W,in}	V _{DDCA} , V _{DDQ}	4
All-bank REFRESH burst current: ^t CK = ^t CK _{min} ; CKE is HIGH between valid commands; ^t RC = ^t RFC _{abmin} ; Burst refresh; CA bus inputs are switching; Data bus inputs are stable	I _{DD51}	V _{DD1}	
	I _{DD52}	V _{DD2}	
	I _{DD5IN}	V _{DDCA} , V _{DDQ}	4

Table 58: I_{DD} Specification Parameters and Operating Conditions (Continued)

Notes 1–3 apply to all parameters and conditions

Parameter/Condition	Symbol	Power Supply	Notes
All-bank REFRESH average current: ^t CK = ^t CKmin; CKE is HIGH between valid commands; ^t RC = ^t REFI; CA bus inputs are switching; Data bus inputs are stable	I _{DD5AB1}	V _{DD1}	
	I _{DD5AB2}	V _{DD2}	
	I _{DD5AB,in}	V _{DDCA} , V _{DDQ}	4
Self refresh current (–40°C to +85°C): CK = LOW, CK# = HIGH; CKE is LOW; CA bus inputs are stable; Data bus inputs are stable; Maximum 1x self refresh rate	I _{DD61}	V _{DD1}	7
	I _{DD62}	V _{DD2}	7
	I _{DD6IN}	V _{DDCA} , V _{DDQ}	4, 7
Self refresh current (+85°C to +105°C): CK = LOW, CK# = HIGH; CKE is LOW; CA bus inputs are stable; Data bus inputs are stable	I _{DD6ET1}	V _{DD1}	7, 8
	I _{DD6ET2}	V _{DD2}	7, 8
	I _{DD6ET,in}	V _{DDCA} , V _{DDQ}	4, 7, 8
Self refresh current (+105°C to +125°C): Not available.			9
Deep power-down current: CK = LOW, CK# = HIGH; CKE is LOW; CA bus inputs are stable; Data bus inputs are stable	I _{DD81}	V _{DD1}	8
	I _{DD82}	V _{DD2}	8
	I _{DD8IN}	V _{DDCA} , V _{DDQ}	4, 8

- Notes:
- I_{DD} values are the maximum of the distribution of the arithmetic mean.
 - I_{DD} current specifications are tested after the device is properly initialized.
 - The 1x self refresh rate is the rate at which the device is refreshed internally during self refresh, before going into the extended temperature range.
 - Measured currents are the sum of V_{DDQ} and V_{DDCA}.
 - Guaranteed by design with output reference load and R_{ON} = 40 ohm.
 - Per-bank REFRESH is only applicable for LPDDR2-S4 device densities 1Gb or higher.
 - This is the general definition that applies to full-array self refresh.
 - I_{DD6ET} and I_{DD8} are typical values, are sampled only, and are not tested.
 - When TC > 105°C, self-refresh mode is not available.

AC and DC Operating Conditions

Operation or timing that is not specified is illegal. To ensure proper operation, the device must be initialized properly.

Table 59: Recommended DC Operating Conditions

Symbol	LPDDR2-S4B			Power Supply	Unit
	Min	Typ	Max		
V _{DD1} ¹	1.70	1.80	1.95	Core power 1	V
V _{DD2}	1.14	1.20	1.30	Core power 2	V
V _{DDCA}	1.14	1.20	1.30	Input buffer power	V
V _{DDQ}	1.14	1.20	1.30	I/O buffer power	V

Note: 1. V_{DD1} uses significantly less power than V_{DD2}.

Table 60: Input Leakage Current

Parameter/Condition	Symbol	Min	Max	Unit	Notes
Input leakage current: For CA, CKE, CS#, CK, CK#; Any input $0V \leq V_{IN} \leq V_{DDCA}$; (All other pins not under test = 0V)	I_L	-2	2	μA	1
V_{REF} supply leakage current: $V_{REFDQ} = V_{DDQ}/2$, or $V_{REFCA} = V_{DDCA}/2$; (All other pins not under test = 0V)	I_{VREF}	-1	1	μA	2

- Notes:
- Although DM is for input only, the DM leakage must match the DQ and DQS/DQS# output leakage specification.
 - The minimum limit requirement is for testing purposes. The leakage current on V_{REFCA} and V_{REFDQ} pins should be minimal.

Table 61: Operating Temperature Range

Parameter/Condition	Symbol	Min	Max	Unit
IT temperature range	T_{CASE}^1	-40	+85	$^{\circ}C$
AT temperature range		-40	+105	$^{\circ}C$
UT temperature range		-40	+125	$^{\circ}C$

- Notes:
- Operating temperature is the case surface temperature at the center of the top side of the device. For measurement conditions, refer to the JESD51-2 standard.
 - Some applications require operation in the maximum case temperature range, between $85^{\circ}C$ and $105^{\circ}C$. For some LPDDR2 devices, derating may be necessary to operate in this range (see the MR4 Device Temperature (MA[7:0] = 04h) table).
 - Either the device operating temperature or the temperature sensor can be used to set an appropriate refresh rate, determine the need for AC timing derating, and/or monitor the operating temperature (see Temperature Sensor). When using the temperature sensor, the actual device case temperature may be higher than the T_{CASE} rating that applies for the operating temperature range. For example, T_{CASE} could be above $85^{\circ}C$ when the temperature sensor indicates a temperature of less than $85^{\circ}C$.
 - UT option use based on automotive usage model. Please contact Micron sales representative if you have questions.

AC and DC Logic Input Measurement Levels for Single-Ended Signals

Table 62: Single-Ended AC and DC Input Levels for CA and CS# Inputs

Symbol	Parameter	LPDDR2-1066 to LPDDR2-466		LPDDR2-400 to LPDDR2-200		Unit	Notes
		Min	Max	Min	Max		
V _{IHCA(AC)}	AC input logic HIGH	V _{REF} + 0.220	Note 2	V _{REF} + 0.300	Note 2	V	1, 2
V _{ILCA(AC)}	AC input logic LOW	Note 2	V _{REF} - 0.220	Note 2	V _{REF} - 0.300	V	1, 2
V _{IHCA(DC)}	DC input logic HIGH	V _{REF} + 0.130	V _{DDCA}	V _{REF} + 0.200	V _{DDCA}	V	1
V _{ILCA(DC)}	DC input logic LOW	V _{SSCA}	V _{REF} - 0.130	V _{SSCA}	V _{REF} - 0.200	V	1
V _{REFCA(DC)}	Reference voltage for CA and CS# inputs	0.49 × V _{DDCA}	0.51 × V _{DDCA}	0.49 × V _{DDCA}	0.51 × V _{DDCA}	V	3, 4

- Notes:
- For CA and CS# input-only pins. V_{REF} = V_{REFCA(DC)}.
 - See Overshoot and Undershoot Definition.
 - The AC peak noise on V_{REFCA} could prevent V_{REFCA} from deviating more than ±1% V_{DDCA} from V_{REFCA(DC)} (for reference, approximately ±12mV).
 - For reference, approximately V_{DDCA}/2 ±12mV.

Table 63: Single-Ended AC and DC Input Levels for CKE

Symbol	Parameter	Min	Max	Unit	Notes
V _{IHCKE}	CKE input HIGH level	0.8 × V _{DDCA}	Note 1	V	1
V _{ILCKE}	CKE input LOW level	Note 1	0.2 × V _{DDCA}	V	1

- Note:
- See Overshoot and Undershoot Definition.

Table 64: Single-Ended AC and DC Input Levels for DQ and DM

Symbol	Parameter	LPDDR2-1066 to LPDDR2-466		LPDDR2-400 to LPDDR2-200		Unit	Notes
		Min	Max	Min	Max		
V _{IHDQ(AC)}	AC input logic HIGH	V _{REF} + 0.220	Note 2	V _{REF} + 0.300	Note 2	V	1, 2
V _{ILDQ(AC)}	AC input logic LOW	Note 2	V _{REF} - 0.220	Note 2	V _{REF} - 0.300	V	1, 2
V _{IHDQ(DC)}	DC input logic HIGH	V _{REF} + 0.130	V _{DDQ}	V _{REF} + 0.200	V _{DDQ}	V	1
V _{ILDQ(DC)}	DC input logic LOW	V _{SSQ}	V _{REF} - 0.130	V _{SSQ}	V _{REF} - 0.200	V	1
V _{REFDQ(DC)}	Reference voltage for DQ and DM inputs	0.49 × V _{DDQ}	0.51 × V _{DDQ}	0.49 × V _{DDQ}	0.51 × V _{DDQ}	V	3, 4

- Notes:
- For DQ input-only pins. V_{REF} = V_{REFDQ(DC)}.
 - See Overshoot and Undershoot Definition.
 - The AC peak noise on V_{REFDQ} could prevent V_{REFDQ} from deviating more than ±1% V_{DDQ} from V_{REFDQ(DC)} (for reference, approximately ±12mV).
 - For reference, approximately V_{DDQ}/2 ±12mV.

V_{REF} Tolerances

The DC tolerance limits and AC noise limits for the reference voltages V_{REFCA} and V_{REFDQ} are illustrated below. This figure shows a valid reference voltage $V_{REF}(t)$ as a function of time. V_{DD} is used in place of V_{DDCA} for V_{REFCA} , and V_{DDQ} for V_{REFDQ} . $V_{REF(DC)}$ is the linear average of $V_{REF}(t)$ over a very long period of time (for example, 1 second) and is specified as a fraction of the linear average of V_{DDQ} or V_{DDCA} , also over a very long period of time (for example, 1 second). This average must meet the MIN/MAX requirements in Table 62 (page 98). Additionally, $V_{REF}(t)$ can temporarily deviate from $V_{REF(DC)}$ by no more than $\pm 1\% V_{DD}$. $V_{REF}(t)$ cannot track noise on V_{DDQ} or V_{DDCA} if doing so would force V_{REF} outside these specifications.

Figure 64: V_{REF} DC Tolerance and V_{REF} AC Noise Limits

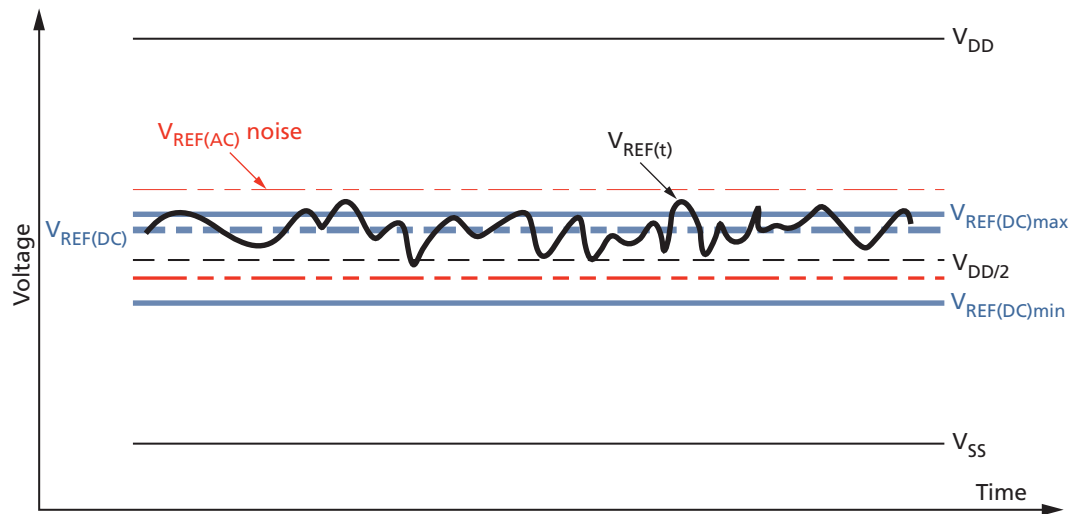

The voltage levels for setup and hold time measurements $V_{IH(AC)}$, $V_{IH(DC)}$, $V_{IL(AC)}$, and $V_{IL(DC)}$ are dependent on V_{REF} .

V_{REF} DC variations affect the absolute voltage a signal must reach to achieve a valid HIGH or LOW, as well as the time from which setup and hold times are measured. When V_{REF} is outside the specified levels, devices will function correctly with appropriate timing deratings as long as:

- V_{REF} is maintained between $0.44 \times V_{DDQ}$ (or V_{DDCA}) and $0.56 \times V_{DDQ}$ (or V_{DDCA}), and
- the controller achieves the required single-ended AC and DC input levels from instantaneous V_{REF} (see Table 62 (page 98)).

System timing and voltage budgets must account for V_{REF} deviations outside this range.

The setup/hold specification and derating values must include time and voltage associated with V_{REF} AC noise. Timing and voltage effects due to AC noise on V_{REF} up to the specified limit ($\pm 1\% V_{DD}$) are included in LPDDR2 timings and their associated deratings.

Input Signal

Figure 65: LPDDR2-466 to LPDDR2-1066 Input Signal

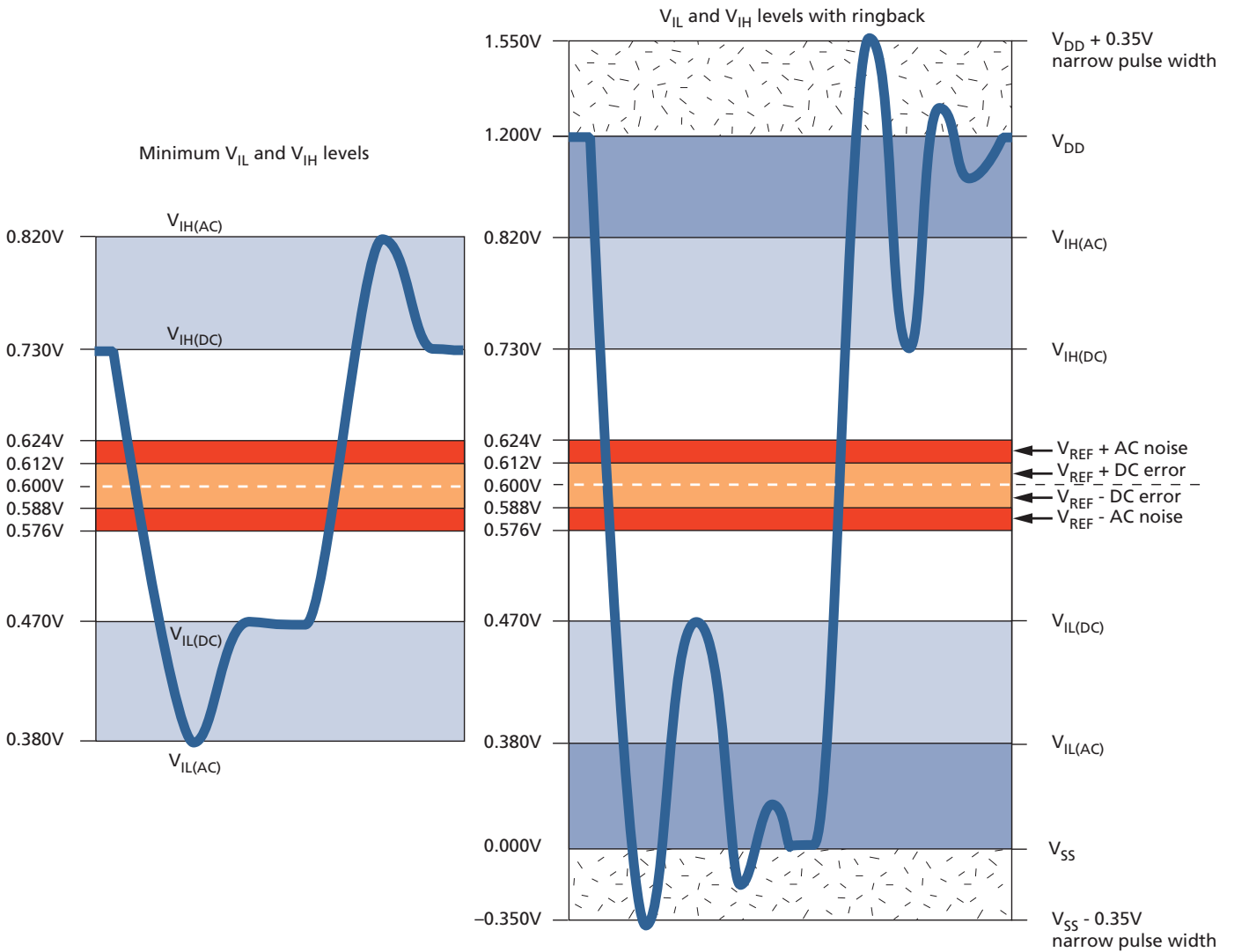

- Notes:
1. Numbers reflect typical values.
 2. For CA[9:0], CK, CK#, and CS# V_{DD} stands for V_{DDCA} . For DQ, DM, DQS, and DQS#, V_{DD} stands for V_{DDQ} .
 3. For CA[9:0], CK, CK#, and CS# V_{SS} stands for V_{SSCA} . For DQ, DM, DQS, and DQS#, V_{SS} stands for V_{SSQ} .

Figure 66: LPDDR2-200 to LPDDR2-400 Input Signal

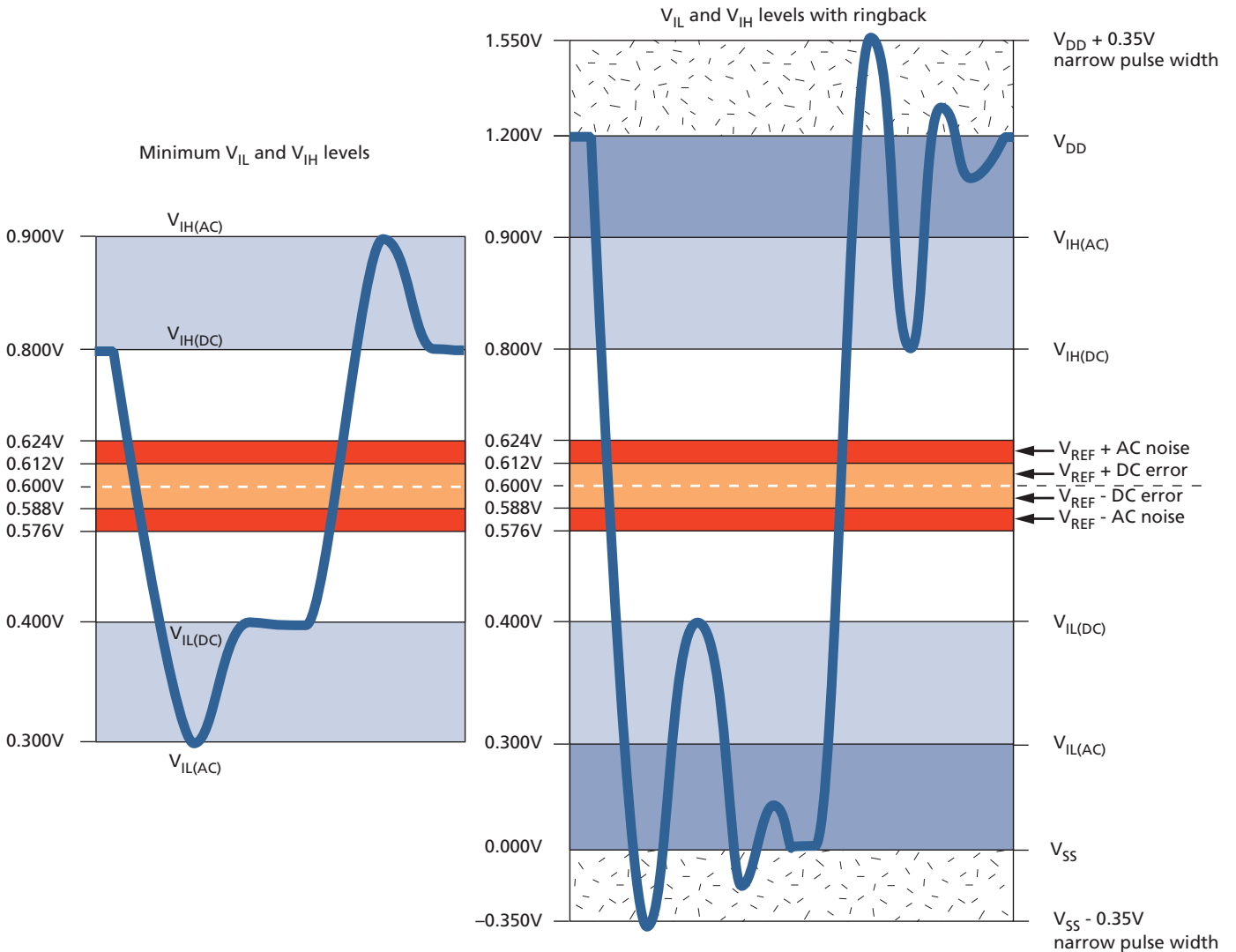

- Notes:
1. Numbers reflect typical values.
 2. For CA[9:0], CK, CK#, and CS# V_{DD} stands for V_{DDCA} . For DQ, DM, DQS, and DQS#, V_{DD} stands for V_{DDQ} .
 3. For CA[9:0], CK, CK#, and CS# V_{SS} stands for V_{SSCA} . For DQ, DM, DQS, and DQS#, V_{SS} stands for V_{SSQ} .

AC and DC Logic Input Measurement Levels for Differential Signals

Figure 67: Differential AC Swing Time and t_{DVAC}

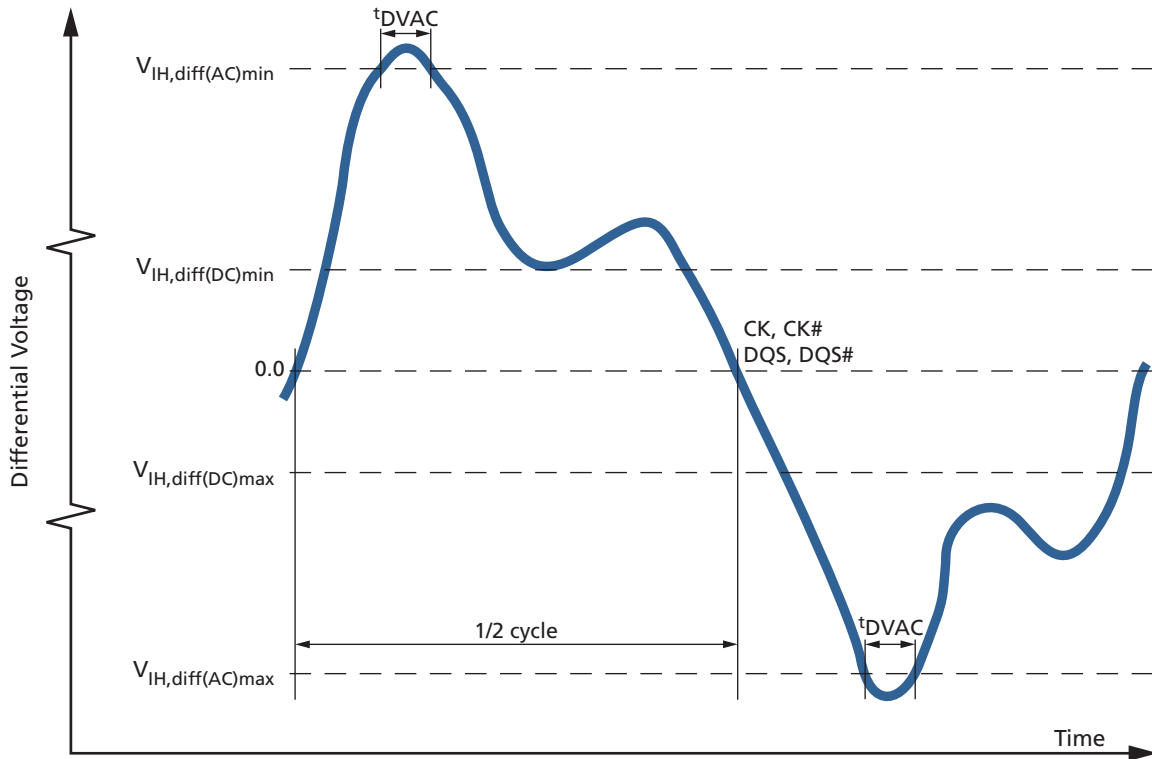

Table 65: Differential AC and DC Input Levels

For CK and CK#, $V_{REF} = V_{REFCA(DC)}$; For DQS and DQS# $V_{REF} = V_{REFDQ(DC)}$

Symbol	Parameter	LPDDR2-1066 to LPDDR2-466		LPDDR2-400 to LPDDR2-200		Unit	Notes
		Min	Max	Min	Max		
$V_{IH,diff(AC)}$	Differential input HIGH AC	$2 \times (V_{IH(AC)} - V_{REF})$	Note 1	$2 \times (V_{IH(AC)} - V_{REF})$	Note 1	V	2
$V_{IL,diff(AC)}$	Differential input LOW AC	Note 1	$2 \times (V_{REF} - V_{IL(AC)})$	Note 1	$2 \times (V_{REF} - V_{IL(AC)})$	V	2
$V_{IH,diff(DC)}$	Differential input HIGH	$2 \times (V_{IH(DC)} - V_{REF})$	Note 1	$2 \times (V_{IH(DC)} - V_{REF})$	Note 1	V	3
$V_{IL,diff(DC)}$	Differential input LOW	Note 1	$2 \times (V_{REF} - V_{IL(DC)})$	Note 1	$2 \times (V_{REF} - V_{IL(DC)})$	V	3

Notes: 1. These values are not defined, however the single-ended signals CK, CK#, DQS, and DQS# must be within the respective limits ($V_{IH(DC)max}$, $V_{IL(DC)min}$) for single-ended signals and must comply with the specified limitations for overshoot and undershoot (see Overshoot and Undershoot Definition).



512Mb: x32 Automotive Mobile LPDDR2 SDRAM AC and DC Logic Input Measurement Levels for Differential Signals

2. For CK and CK#, use $V_{IH}/V_{IL(AC)}$ of CA and V_{REFCA} ; for DQS and DQS#, use $V_{IH}/V_{IL(AC)}$ of DQ and V_{REFDQ} . If a reduced AC HIGH or AC LOW is used for a signal group, the reduced voltage level also applies.
3. Used to define a differential signal slew rate.

Table 66: CK/CK# and DQS/DQS# Time Requirements Before Ringback (t^{DVAC})

Slew Rate (V/ns)	t^{DVAC} (ps) at $V_{IH}/V_{ILdiff(AC)} = 440mV$	t^{DVAC} (ps) at $V_{IH}/V_{ILdiff(AC)} = 600mV$
	Min	Min
> 4.0	175	75
4.0	170	57
3.0	167	50
2.0	163	38
1.8	162	34
1.6	161	29
1.4	159	22
1.2	155	13
1.0	150	0
< 1.0	150	0

Single-Ended Requirements for Differential Signals

Each individual component of a differential signal (CK, CK#, DQS, and DQS#) must also comply with certain requirements for single-ended signals.

CK and CK# must meet $V_{SEH(AC)min}/V_{SEL(AC)max}$ in every half cycle. DQS, DQS# must meet $V_{SEH(AC)min}/V_{SEL(AC)max}$ in every half cycle preceding and following a valid transition.

The applicable AC levels for CA and DQ differ by speed bin.

Figure 68: Single-Ended Requirements for Differential Signals

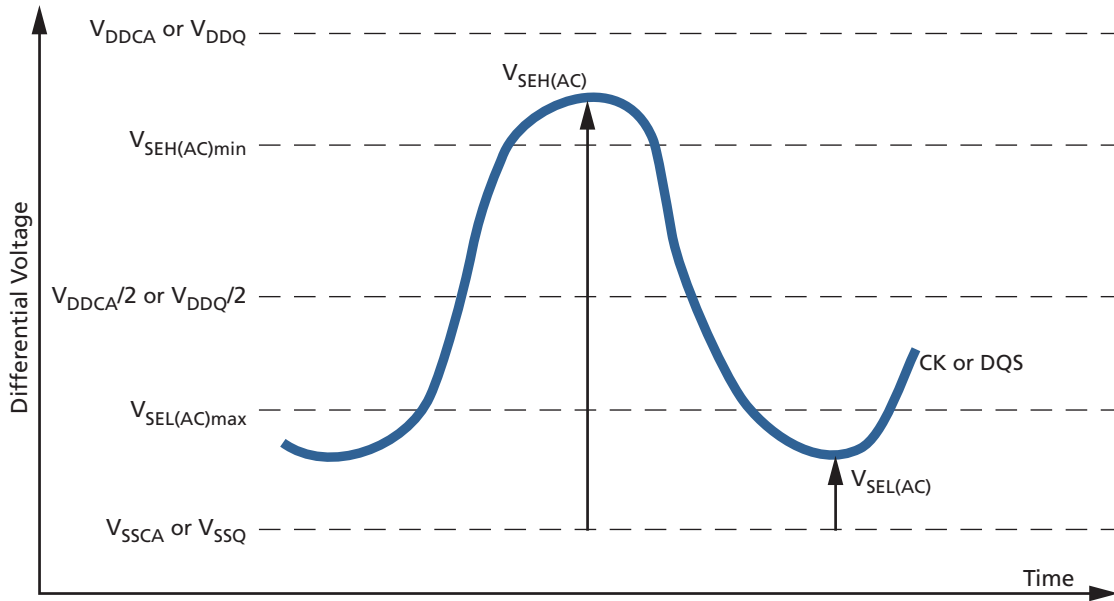

Note that while CA and DQ signal requirements are referenced to V_{REF} , the single-ended components of differential signals also have a requirement with respect to $V_{DDQ}/2$ for DQS, and $V_{DDCA}/2$ for CK.

The transition of single-ended signals through the AC levels is used to measure setup time. For single-ended components of differential signals, the requirement to reach $V_{SEL(AC)max}$ or $V_{SEH(AC)min}$ has no bearing on timing. This requirement does, however, add a restriction on the common mode characteristics of these signals (see "Single-Ended AC and DC Input Levels for CA and CS# Inputs" for CK/CK# single-ended requirements, and "Single-Ended AC and DC Input Levels for DQ and DM" for DQ and DQM single-ended requirements).

Table 67: Single-Ended Levels for CK, CK#, DQS, DQS#

Symbol	Parameter	LPDDR2-1066 to LPDDR2-466		LPDDR2-400 to LPDDR2-200		Unit	Notes
		Min	Max	Min	Max		
$V_{SEH(AC)}$	Single-ended HIGH level for strobes	$(V_{DDQ}/2) + 0.220$	Note 1	$(V_{DDQ}/2) + 0.300$	Note 1	V	2, 3
	Single-ended HIGH level for CK, CK#	$(V_{DDCA}/2) + 0.220$	Note 1	$(V_{DDCA}/2) + 0.300$	Note 1	V	2, 3
$V_{SEL(AC)}$	Single-ended LOW level for strobes	Note 1	$(V_{DDQ}/2) - 0.220$	Note 1	$(V_{DDQ}/2) - 0.300$	V	2, 3
	Single-ended LOW level for CK, CK#	Note 1	$(V_{DDCA}/2) - 0.220$	Note 1	$(V_{DDCA}/2) - 0.300$	V	2, 3

Notes: 1. These values are not defined, however, the single-ended signals CK, CK#, DQS0, DQS#0, DQS1, DQS#1, DQS2, DQS#2, DQS3, DQS#3 must be within the respective limits ($V_{IH(DC)max}/V_{IL(DC)min}$) for single-ended signals, and must comply with the specified limitations for overshoot and undershoot (See Overshoot and Undershoot Definition).

2. For CK and CK#, use $V_{SEH}/V_{SEL(AC)}$ of CA; for strobes (DQS[3:0] and DQS#[3:0]), use $V_{IH}/V_{IL(AC)}$ of DQ.
3. $V_{IH(AC)}$ and $V_{IL(AC)}$ for DQ are based on V_{REFDQ} ; $V_{SEH(AC)}$ and $V_{SEL(AC)}$ for CA are based on V_{REFCA} . If a reduced AC HIGH or AC LOW is used for a signal group, the reduced level applies.

Differential Input Crosspoint Voltage

To ensure tight setup and hold times as well as output skew parameters with respect to clock and strobe, each crosspoint voltage of differential input signals (CK, CK#, DQS, and DQS#) must meet the specifications in Table 67 (page 104). The differential input crosspoint voltage (V_{IX}) is measured from the actual crosspoint of the true signal and its complement to the midlevel between V_{DD} and V_{SS} .

Figure 69: V_{IX} Definition

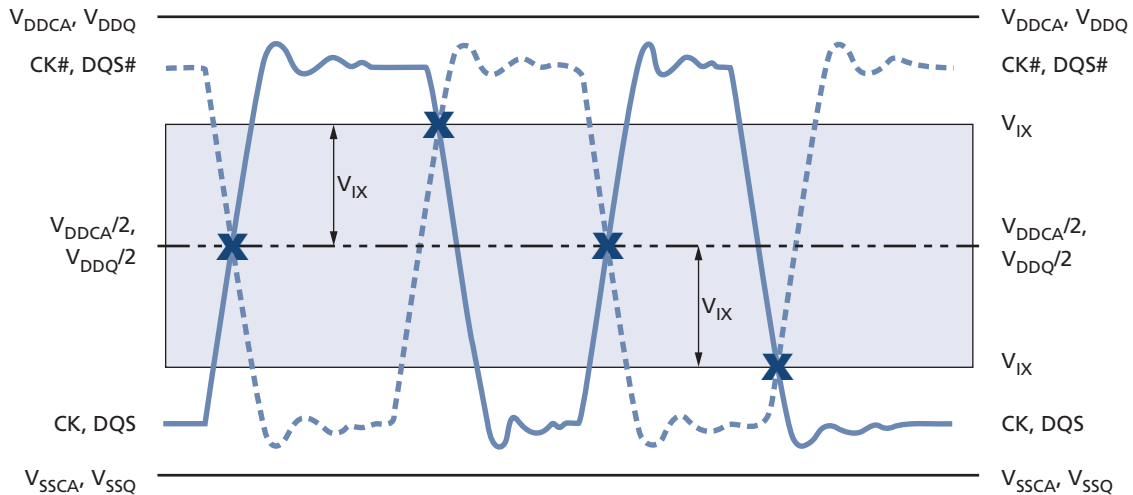

Table 68: Crosspoint Voltage for Differential Input Signals (CK, CK#, DQS, DQS#)

Symbol	Parameter	LPDDR2-1066 to LPDDR2-200		Unit	Notes
		Min	Max		
$V_{IXCA(AC)}$	Differential input crosspoint voltage relative to $V_{DDCA}/2$ for CK and CK#	-120	120	mV	1, 2
$V_{IXDQ(AC)}$	Differential input crosspoint voltage relative to $V_{DDQ}/2$ for DQS and DQ#	-120	120	mV	1, 2

- Notes:
1. The typical value of $V_{IX(AC)}$ is expected to be about $0.5 \times V_{DD}$ of the transmitting device, and it is expected to track variations in V_{DD} . $V_{IX(AC)}$ indicates the voltage at which differential input signals must cross.
 2. For CK and CK#, $V_{REF} = V_{REFCA(DC)}$. For DQS and DQS#, $V_{REF} = V_{REFDQ(DC)}$.

Input Slew Rate

Table 69: Differential Input Slew Rate Definition

Description	Measured ¹		Defined by
	From	To	
Differential input slew rate for rising edge (CK/CK# and DQS/DQS#)	$V_{IL,diff,max}$	$V_{IH,diff,min}$	$[V_{IH,diff,min} - V_{IL,diff,max}] / \Delta TR_{diff}$
Differential input slew rate for falling edge (CK/CK# and DQS/DQS#)	$V_{IH,diff,min}$	$V_{IL,diff,max}$	$[V_{IH,diff,min} - V_{IL,diff,max}] / \Delta TF_{diff}$

Note: 1. The differential signals (CK/CK# and DQS/DQS#) must be linear between these thresholds.

Figure 70: Differential Input Slew Rate Definition for CK, CK#, DQS, and DQS#

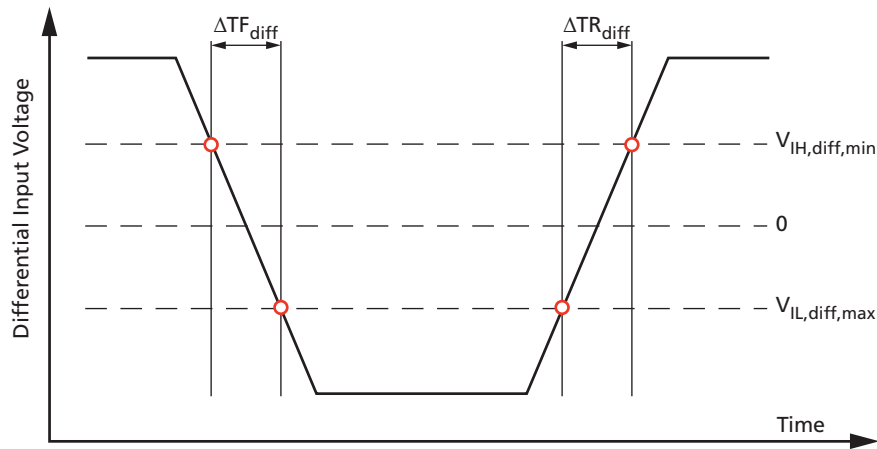

Output Characteristics and Operating Conditions

Table 70: Single-Ended AC and DC Output Levels

Symbol	Parameter	Value	Unit	Notes
$V_{OH(AC)}$	AC output HIGH measurement level (for output slew rate)	$V_{REF} + 0.12$	V	
$V_{OL(AC)}$	AC output LOW measurement level (for output slew rate)	$V_{REF} - 0.12$	V	
$V_{OH(DC)}$	DC output HIGH measurement level (for I-V curve linearity)	$0.9 \times V_{DDQ}$	V	1
$V_{OL(DC)}$	DC output LOW measurement level (for I-V curve linearity)	$0.1 \times V_{DDQ}$	V	2
I_{OZ}	Output leakage current (DQ, DM, DQS, DQS#); DQ, DQS, DQS# are disabled; $0V \leq V_{OUT} \leq V_{DDQ}$	MIN	-5	μA
		MAX	+5	μA
MMpupd	Delta output impedance between pull-up and pull-down for DQ/DM	MIN	-15	%
		MAX	+15	%

Notes: 1. $I_{OH} = -0.1mA$.
2. $I_{OL} = 0.1mA$.

Table 71: Differential AC and DC Output Levels

Symbol	Parameter	Value	Unit
$V_{OHdiff(AC)}$	AC differential output HIGH measurement level (for output SR)	$+ 0.2 \times V_{DDQ}$	V
$V_{OLdiff(AC)}$	AC differential output LOW measurement level (for output SR)	$- 0.2 \times V_{DDQ}$	V

Single-Ended Output Slew Rate

With the reference load for timing measurements, the output slew rate for falling and rising edges is defined and measured between $V_{OL(AC)}$ and $V_{OH(AC)}$ for single-ended signals.

Table 72: Single-Ended Output Slew Rate Definition

Description	Measured		Defined by
	From	To	
Single-ended output slew rate for rising edge	$V_{OL(AC)}$	$V_{OH(AC)}$	$[V_{OH(AC)} - V_{OL(AC)}] / \Delta TR_{SE}$
Single-ended output slew rate for falling edge	$V_{OH(AC)}$	$V_{OL(AC)}$	$[V_{OH(AC)} - V_{OL(AC)}] / \Delta TF_{SE}$

Note: 1. Output slew rate is verified by design and characterization and may not be subject to production testing.

Figure 71: Single-Ended Output Slew Rate Definition

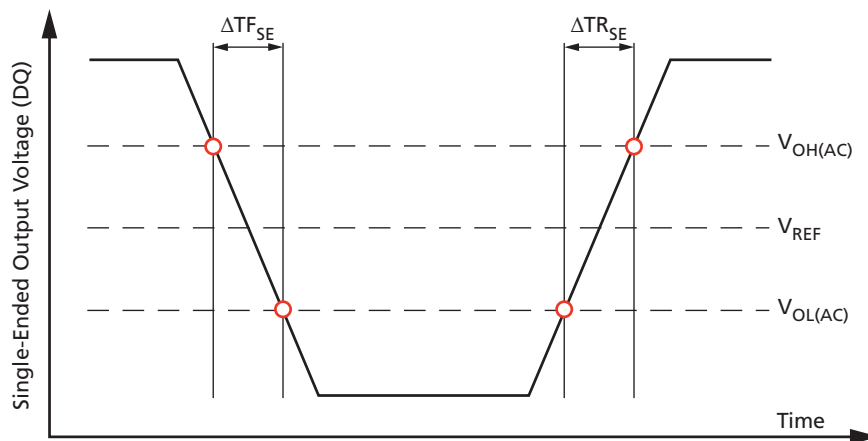

Table 73: Single-Ended Output Slew Rate

Notes 1–5 apply to all parameters conditions

Parameter	Symbol	Value		Unit
		Min	Max	
Single-ended output slew rate (output impedance = $40\Omega \pm 30\%$)	SRQ_{SE}	1.5	3.5	V/ns
Single-ended output slew rate (output impedance = $60\Omega \pm 30\%$)	SRQ_{SE}	1.0	2.5	V/ns

Table 73: Single-Ended Output Slew Rate (Continued)

Notes 1–5 apply to all parameters conditions

Parameter	Symbol	Value		Unit
		Min	Max	
Output slew-rate-matching ratio (pull-up to pull-down)		0.7	1.4	–

- Notes:
1. Definitions: SR = slew rate; Q = output (similar to DQ = data-in, data-out); SE = single-ended signals.
 2. Measured with output reference load.
 3. The ratio of pull-up to pull-down slew rate is specified for the same temperature and voltage over the entire temperature and voltage range. For a given output, the ratio represents the maximum difference between pull-up and pull-down drivers due to process variation.
 4. The output slew rate for falling and rising edges is defined and measured between $V_{OL(AC)}$ and $V_{OH(AC)}$.
 5. Slew rates are measured under typical simultaneous switching output (SSO) conditions, with one-half of DQ signals per data byte driving HIGH and one-half of DQ signals per data byte driving LOW.

Differential Output Slew Rate

With the reference load for timing measurements, the output slew rate for falling and rising edges is defined and measured between $V_{OL,diff(AC)}$ and $V_{OH,diff(AC)}$ for differential signals.

Table 74: Differential Output Slew Rate Definition

Description	Measured		Defined by
	From	To	
Differential output slew rate for rising edge	$V_{OL,diff(AC)}$	$V_{OH,diff(AC)}$	$[V_{OH,diff(AC)} - V_{OL,diff(AC)}] / \Delta TR_{diff}$
Differential output slew rate for falling edge	$V_{OH,diff(AC)}$	$V_{OL,diff(AC)}$	$[V_{OH,diff(AC)} - V_{OL,diff(AC)}] / \Delta TF_{diff}$

- Note:
1. Output slew rate is verified by design and characterization and may not be subject to production testing.

Figure 72: Differential Output Slew Rate Definition

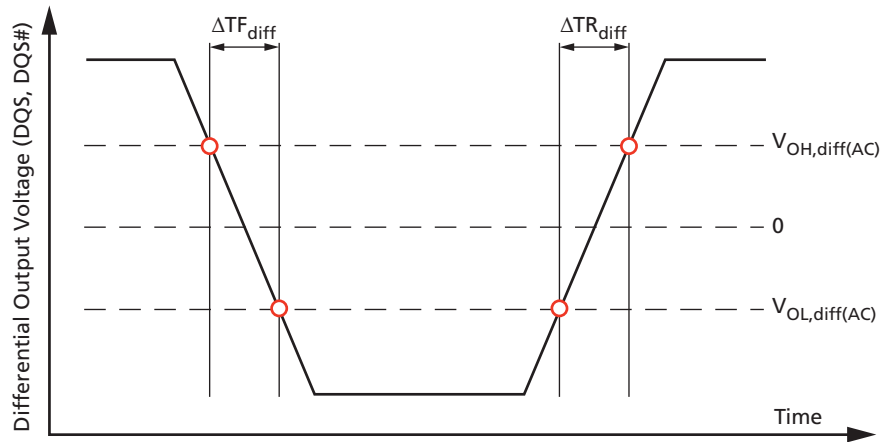

Table 75: Differential Output Slew Rate

Parameter	Symbol	Value		Unit
		Min	Max	
Differential output slew rate (output impedance = 40Ω ±30%)	SRQ _{diff}	3.0	7.0	V/ns
Differential output slew rate (output impedance = 60Ω ±30%)	SRQ _{diff}	2.0	5.0	V/ns

- Notes:
- Definitions: SR = slew rate; Q = output (similar to DQ = data-in, data-out); SE = single-ended signals.
 - Measured with output reference load.
 - The output slew rate for falling and rising edges is defined and measured between V_{OL(AC)} and V_{OH(AC)}.
 - Slew rates are measured under typical simultaneous switching output (SSO) conditions, with one-half of DQ signals per data byte driving HIGH and one-half of DQ signals per data byte driving LOW.

Table 76: AC Overshoot/Undershoot Specification

Applies for CA[9:0], CS#, CKE, CK, CK#, DQ, DQS, DQS#, DM

Parameter	1066	933	800	667	533	400	333	Unit
Maximum peak amplitude provided for overshoot area	0.35	0.35	0.35	0.35	0.35	0.35	0.35	V
Maximum peak amplitude provided for undershoot area	0.35	0.35	0.35	0.35	0.35	0.35	0.35	V
Maximum area above V _{DD} ¹	0.15	0.17	0.20	0.24	0.30	0.40	0.48	V/ns
Maximum area below V _{SS} ²	0.15	0.17	0.20	0.24	0.30	0.40	0.48	V/ns

- Notes:
- V_{DD} stands for V_{DDCA} for CA[9:0], CK, CK#, CS#, and CKE. V_{DD} stands for V_{DDQ} for DQ, DM, DQS, and DQS#.
 - V_{SS} stands for V_{SSCA} for CA[9:0], CK, CK#, CS#, and CKE. V_{SS} stands for V_{SSQ} for DQ, DM, DQS, and DQS#.

Figure 73: Overshoot and Undershoot Definition

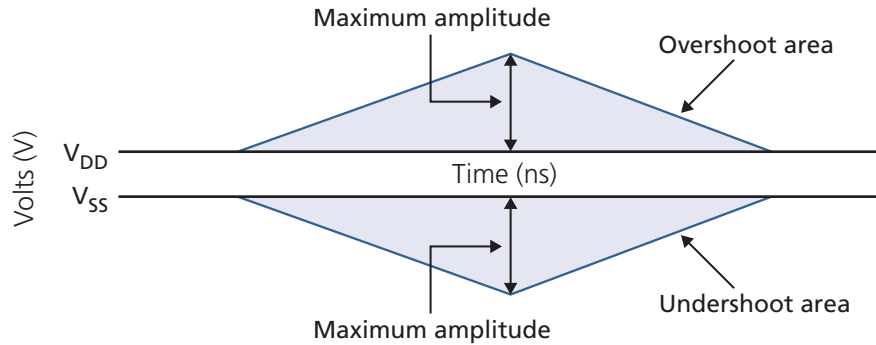

- Notes:
1. V_{DD} stands for V_{DDCA} for CA[9:0], CK, CK#, CS#, and CKE. V_{DD} stands for V_{DDQ} for DQ, DM, DQS, and DQS#.
 2. V_{SS} stands for V_{SSCA} for CA[9:0], CK, CK#, CS#, and CKE. V_{SS} stands for V_{SSQ} for DQ, DM, DQS, and DQS#.

HSUL_12 Driver Output Timing Reference Load

The timing reference loads are not intended as a precise representation of any particular system environment or a depiction of the actual load presented by a production tester. System designers should use IBIS or other simulation tools to correlate the timing reference load to a system environment. Manufacturers correlate to their production test conditions, generally with one or more coaxial transmission lines terminated at the tester electronics.

Figure 74: HSUL_12 Driver Output Reference Load for Timing and Slew Rate

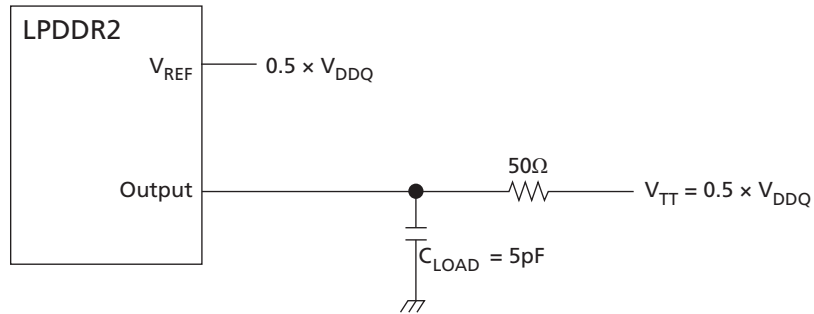

Note: 1. All output timing parameter values (t_{DQSCK} , t_{DQSQ} , t_{QHS} , t_{HZ} , t_{RPRE} etc.) are reported with respect to this reference load. This reference load is also used to report slew rate.

Output Driver Impedance

Output driver impedance is selected by a mode register during initialization. To achieve tighter tolerances, ZQ calibration is required. Output specifications refer to the default output drive unless specifically stated otherwise. The output driver impedance R_{ON} is defined by the value of the external reference resistor R_{ZQ} as follows:

$$R_{ONPU} = \frac{V_{DDQ} - V_{OUT}}{ABS(I_{OUT})}$$

When R_{ONPD} is turned off.

$$R_{ONPD} = \frac{V_{OUT}}{ABS(I_{OUT})}$$

When R_{ONPU} is turned off.

Figure 75: Output Driver

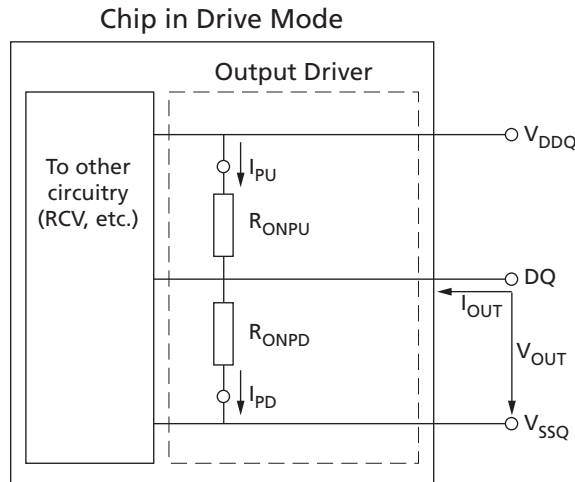

Output Driver Impedance Characteristics with ZQ Calibration

Output driver impedance is defined by the value of the external reference resistor R_{ZQ} . Typical R_{ZQ} is 240 ohms.

Table 77: Output Driver DC Electrical Characteristics with ZQ Calibration

Notes 1–4 apply to all parameters and conditions

R_{ONnom}	Resistor	V_{OUT}	Min	Typ	Max	Unit	Notes
34.3Ω	R_{ON34PD}	$0.5 \times V_{DDQ}$	0.85	1.00	1.15	$R_{ZQ}/7$	
	R_{ON34PU}	$0.5 \times V_{DDQ}$	0.85	1.00	1.15	$R_{ZQ}/7$	
40.0Ω	R_{ON40PD}	$0.5 \times V_{DDQ}$	0.85	1.00	1.15	$R_{ZQ}/6$	
	R_{ON40PU}	$0.5 \times V_{DDQ}$	0.85	1.00	1.15	$R_{ZQ}/6$	
48.0Ω	R_{ON48PD}	$0.5 \times V_{DDQ}$	0.85	1.00	1.15	$R_{ZQ}/5$	
	R_{ON48PU}	$0.5 \times V_{DDQ}$	0.85	1.00	1.15	$R_{ZQ}/5$	
60.0Ω	R_{ON60PD}	$0.5 \times V_{DDQ}$	0.85	1.00	1.15	$R_{ZQ}/4$	
	R_{ON60PU}	$0.5 \times V_{DDQ}$	0.85	1.00	1.15	$R_{ZQ}/4$	
80.0Ω	R_{ON80PD}	$0.5 \times V_{DDQ}$	0.85	1.00	1.15	$R_{ZQ}/3$	
	R_{ON80PU}	$0.5 \times V_{DDQ}$	0.85	1.00	1.15	$R_{ZQ}/3$	
120.0Ω	$R_{ON120PD}$	$0.5 \times V_{DDQ}$	0.85	1.00	1.15	$R_{ZQ}/2$	
	$R_{ON120PU}$	$0.5 \times V_{DDQ}$	0.85	1.00	1.15	$R_{ZQ}/2$	
Mismatch between pull-up and pull-down	MM_{PUPD}		-15.00		+15.00	%	5

- Notes:
1. Applies across entire operating temperature range after calibration.
 2. $R_{ZQ} = 240\Omega$.
 3. The tolerance limits are specified after calibration, with fixed voltage and temperature. For behavior of the tolerance limits if temperature or voltage changes after calibration, see Output Driver Temperature and Voltage Sensitivity.
 4. Pull-down and pull-up output driver impedances should be calibrated at $0.5 \times V_{DDQ}$.
 5. Measurement definition for mismatch between pull-up and pull-down, MM_{PUPD} :



Measure R_{ONPU} and R_{ONPD} , both at $0.5 \times V_{DDQ}$:

$$MM_{PUPD} = \frac{R_{ONPU} - R_{ONPD}}{R_{ON,nom}} \times 100$$

For example, with $MM_{PUPD} (MAX) = 15\%$ and $R_{ONPD} = 0.85$, R_{ONPU} must be less than 1.0.

Output Driver Temperature and Voltage Sensitivity

If temperature and/or voltage change after calibration, the tolerance limits widen.

Table 78: Output Driver Sensitivity Definition

Resistor	V_{OUT}	Min	Max	Unit
R_{ONPD}	$0.5 \times V_{DDQ}$	$85 - (dR_{ONdT} \cdot \Delta T) - (dR_{ONdV} \cdot \Delta V)$	$115 + (dR_{ONdT} \cdot \Delta T) - (dR_{ONdV} \cdot \Delta V)$	%
R_{ONPU}				

- Notes: 1. $\Delta T = T - T$ (at calibration). $\Delta V = V - V$ (at calibration).
2. dR_{ONdT} and dR_{ONdV} are not subject to production testing; they are verified by design and characterization.

Table 79: Output Driver Temperature and Voltage Sensitivity

Symbol	Parameter	Min	Max	Unit
R_{ONdT}	R_{ON} temperature sensitivity	0.00	0.75	%/°C
R_{ONdV}	R_{ON} voltage sensitivity	0.00	0.20	%/mV

Output Impedance Characteristics Without ZQ Calibration

Output driver impedance is defined by design and characterization as the default setting.

Table 80: Output Driver DC Electrical Characteristics Without ZQ Calibration

$R_{ON,nom}$	Resistor	V_{OUT}	Min	Typ	Max	Unit
34.3Ω	R_{ON34PD}	$0.5 \times V_{DDQ}$	0.70	1.00	1.30	$R_{ZQ}/7$
	R_{ON34PU}	$0.5 \times V_{DDQ}$	0.70	1.00	1.30	$R_{ZQ}/7$
40.0Ω	R_{ON40PD}	$0.5 \times V_{DDQ}$	0.70	1.00	1.30	$R_{ZQ}/6$
	R_{ON40PU}	$0.5 \times V_{DDQ}$	0.70	1.00	1.30	$R_{ZQ}/6$
48.0Ω	R_{ON48PD}	$0.5 \times V_{DDQ}$	0.70	1.00	1.30	$R_{ZQ}/5$
	R_{ON48PU}	$0.5 \times V_{DDQ}$	0.70	1.00	1.30	$R_{ZQ}/5$
60.0Ω	R_{ON60PD}	$0.5 \times V_{DDQ}$	0.70	1.00	1.30	$R_{ZQ}/4$
	R_{ON60PU}	$0.5 \times V_{DDQ}$	0.70	1.00	1.30	$R_{ZQ}/4$
80.0Ω	R_{ON80PD}	$0.5 \times V_{DDQ}$	0.70	1.00	1.30	$R_{ZQ}/3$
	R_{ON80PU}	$0.5 \times V_{DDQ}$	0.70	1.00	1.30	$R_{ZQ}/3$

Table 80: Output Driver DC Electrical Characteristics Without ZQ Calibration (Continued)

RON _{nom}	Resistor	V _{OUT}	Min	Typ	Max	Unit
120.0Ω	R _{ON120PD}	0.5 × V _{DDQ}	0.70	1.00	1.30	R _{ZQ} /2
	R _{ON120PU}	0.5 × V _{DDQ}	0.70	1.00	1.30	R _{ZQ} /2

- Notes: 1. Applies across entire operating temperature range without calibration.
2. R_{ZQ} = 240Ω.

Table 81: I-V Curves

Voltage (V)	R _{ON} = 240Ω (R _{ZQ})							
	Pull-Down				Pull-Up			
	Current (mA) / R _{ON} (ohms)				Current (mA) / R _{ON} (ohms)			
	Default Value after ZQRESET		With Calibration		Default Value after ZQRESET		With Calibration	
	Min (mA)	Max (mA)	Min (mA)	Max (mA)	Min (mA)	Max (mA)	Min (mA)	Max (mA)
0.00	0.00	0.00	0.00	0.00	0.00	0.00	0.00	0.00
0.05	0.19	0.32	0.21	0.26	-0.19	-0.32	-0.21	-0.26
0.10	0.38	0.64	0.40	0.53	-0.38	-0.64	-0.40	-0.53
0.15	0.56	0.94	0.60	0.78	-0.56	-0.94	-0.60	-0.78
0.20	0.74	1.26	0.79	1.04	-0.74	-1.26	-0.79	-1.04
0.25	0.92	1.57	0.98	1.29	-0.92	-1.57	-0.98	-1.29
0.30	1.08	1.86	1.17	1.53	-1.08	-1.86	-1.17	-1.53
0.35	1.25	2.17	1.35	1.79	-1.25	-2.17	-1.35	-1.79
0.40	1.40	2.46	1.52	2.03	-1.40	-2.46	-1.52	-2.03
0.45	1.54	2.74	1.69	2.26	-1.54	-2.74	-1.69	-2.26
0.50	1.68	3.02	1.86	2.49	-1.68	-3.02	-1.86	-2.49
0.55	1.81	3.30	2.02	2.72	-1.81	-3.30	-2.02	-2.72
0.60	1.92	3.57	2.17	2.94	-1.92	-3.57	-2.17	-2.94
0.65	2.02	3.83	2.32	3.15	-2.02	-3.83	-2.32	-3.15
0.70	2.11	4.08	2.46	3.36	-2.11	-4.08	-2.46	-3.36
0.75	2.19	4.31	2.58	3.55	-2.19	-4.31	-2.58	-3.55
0.80	2.25	4.54	2.70	3.74	-2.25	-4.54	-2.70	-3.74
0.85	2.30	4.74	2.81	3.91	-2.30	-4.74	-2.81	-3.91
0.90	2.34	4.92	2.89	4.05	-2.34	-4.92	-2.89	-4.05
0.95	2.37	5.08	2.97	4.23	-2.37	-5.08	-2.97	-4.23
1.00	2.41	5.20	3.04	4.33	-2.41	-5.20	-3.04	-4.33
1.05	2.43	5.31	3.09	4.44	-2.43	-5.31	-3.09	-4.44
1.10	2.46	5.41	3.14	4.52	-2.46	-5.41	-3.14	-4.52
1.15	2.48	5.48	3.19	4.59	-2.48	-5.48	-3.19	-4.59
1.20	2.50	5.55	3.23	4.65	-2.50	-5.55	-3.23	-4.65

Figure 76: Output Impedance = 240 Ohms, I-V Curves After ZQRESET

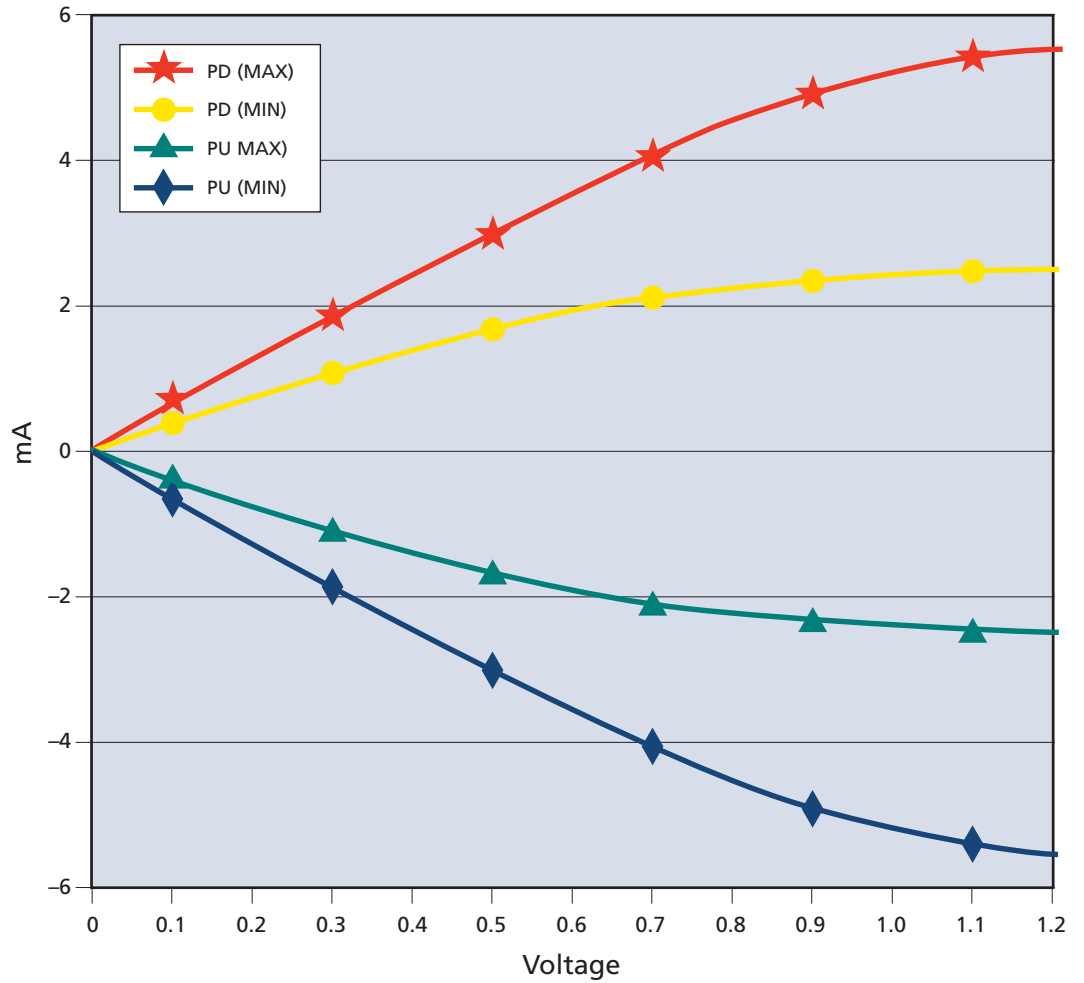
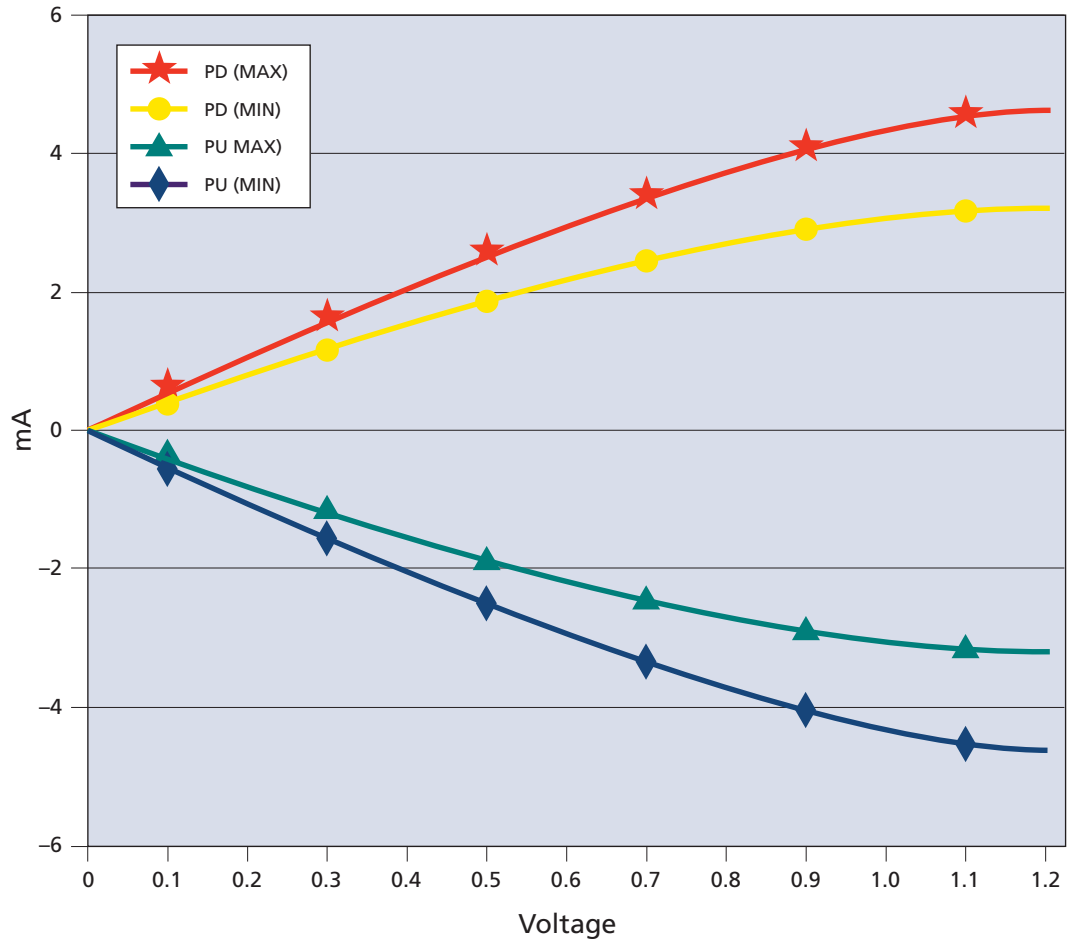

Figure 77: Output Impedance = 240 Ohms, I-V Curves After Calibration



Clock Specification

The specified clock jitter is a random jitter with Gaussian distribution. Input clocks violating minimum or maximum values may result in device malfunction.

Table 82: Definitions and Calculations

Symbol	Description	Calculation	Notes
$t_{CK(avg)}$ and n_{CK}	The average clock period across any consecutive 200-cycle window. Each clock period is calculated from rising clock edge to rising clock edge. Unit $t_{CK(avg)}$ represents the actual clock average $t_{CK(avg)}$ of the input clock under operation. Unit n_{CK} represents one clock cycle of the input clock, counting from actual clock edge to actual clock edge. $t_{CK(avg)}$ can change no more than $\pm 1\%$ within a 100-clock-cycle window, provided that all jitter and timing specifications are met.	$t_{CK(avg)} = \left(\sum_{j=1}^N t_{CK_j} \right) / N$ Where $N = 200$	
$t_{CK(abs)}$	The absolute clock period, as measured from one rising clock edge to the next consecutive rising clock edge.		1
$t_{CH(avg)}$	The average HIGH pulse width, as calculated across any 200 consecutive HIGH pulses.	$t_{CH(avg)} = \left(\sum_{j=1}^N t_{CH_j} \right) / (N \times t_{CK(avg)})$ Where $N = 200$	
$t_{CL(avg)}$	The average LOW pulse width, as calculated across any 200 consecutive LOW pulses.	$t_{CL(avg)} = \left(\sum_{j=1}^N t_{CL_j} \right) / (N \times t_{CK(avg)})$ Where $N = 200$	
$t_{JIT(per)}$	The single-period jitter defined as the largest deviation of any signal t_{CK} from $t_{CK(avg)}$.	$t_{JIT(per)} = \min/\max \text{ of } \left\{ t_{CK_i} - t_{CK(avg)} \right\}$ Where $i = 1 \text{ to } 200$	1
$t_{JIT(per),act}$	The actual clock jitter for a given system.		
$t_{JIT(per),allowed}$	The specified clock period jitter allowance.		
$t_{JIT(cc)}$	The absolute difference in clock periods between two consecutive clock cycles. $t_{JIT(cc)}$ defines the cycle-to-cycle jitter.	$t_{JIT(cc)} = \max \text{ of } \left\{ t_{CK_{i+1}} - t_{CK_i} \right\}$	1
$t_{ERR(nper)}$	The cumulative error across n multiple consecutive cycles from $t_{CK(avg)}$.	$t_{ERR(nper)} = \left(\sum_{j=i}^{i+n-1} t_{CK_j} \right) - (n \times t_{CK(avg)})$	1
$t_{ERR(nper),act}$	The actual cumulative error over n cycles for a given system.		
$t_{ERR(nper),allowed}$	The specified cumulative error allowance over n cycles.		
$t_{ERR(nper),min}$	The minimum $t_{ERR(nper)}$.	$t_{ERR(nper),min} = (1 + 0.68LN(n)) \times t_{JIT(per),min}$	2

Table 82: Definitions and Calculations (Continued)

Symbol	Description	Calculation	Notes
$t_{ERR(nper),max}$	The maximum $t_{ERR(nper)}$.	$t_{ERR(nper),max} = (1 + 0.68LN(n)) \times t_{JIT(per),max}$	2
$t_{JIT(duty)}$	Defined with absolute and average specifications for t_{CH} and t_{CL} , respectively.	$t_{JIT(duty),min} =$ $MIN((t_{CH(ABS),min} - t_{CH(avg),min}),$ $(t_{CL(ABS),min} - t_{CL(avg),min})) \times t_{CK(avg)}$ $t_{JIT(duty),max} =$ $MAX((t_{CH(ABS),max} - t_{CH(avg),max}),$ $(t_{CL(ABS),max} - t_{CL(avg),max})) \times t_{CK(avg)}$	

- Notes: 1. Not subject to production testing.
 2. Using these equations, $t_{ERR(nper)}$ tables can be generated for each $t_{JIT(per),act}$ value.

$t_{CK(ABS)}$, $t_{CH(ABS)}$, and $t_{CL(ABS)}$

These parameters are specified with their average values; however, the relationship between the average timing and the absolute instantaneous timing (defined in the following table) is applicable at all times.

Table 83: $t_{CK(ABS)}$, $t_{CH(ABS)}$, and $t_{CL(ABS)}$ Definitions

Parameter	Symbol	Minimum	Unit
Absolute clock period	$t_{CK(ABS)}$	$t_{CK(avg),min} + t_{JIT(per),min}$	ps ¹
Absolute clock HIGH pulse width	$t_{CH(ABS)}$	$t_{CH(avg),min} + t_{JIT(duty),min}^2/t_{CK(avg),min}$	$t_{CK(avg)}$
Absolute clock LOW pulse width	$t_{CL(ABS)}$	$t_{CL(avg),min} + t_{JIT(duty),min}^2/t_{CK(avg),min}$	$t_{CK(avg)}$

- Notes: 1. $t_{CK(avg),min}$ is expressed in ps for this table.
 2. $t_{JIT(duty),min}$ is a negative value.

Clock Period Jitter

LPDDR2 devices can tolerate some clock period jitter without core timing parameter derating. This section describes device timing requirements with clock period jitter ($t_{JIT(per)}$) in excess of the values found in the AC Timing section. Calculating cycle time derating and clock cycle derating are also described.

Clock Period Jitter Effects on Core Timing Parameters

Core timing parameters (t_{RCD} , t_{RP} , t_{RTP} , t_{WR} , t_{WRA} , t_{WTR} , t_{RC} , t_{RAS} , t_{RRD} , t_{FAW}) extend across multiple clock cycles. Clock period jitter impacts these parameters when measured in numbers of clock cycles. Within the specification limits, the device is characterized and verified to support $n_{PARAM} = RU[t_{PARAM}/t_{CK(avg)}]$. During device operation where clock jitter is outside specification limits, the number of clocks or $t_{CK(avg)}$, may need to be increased based on the values for each core timing parameter.

Cycle Time Derating for Core Timing Parameters

For a given number of clocks (t_{nPARAM}), when $t_{CK(avg)}$ and $t_{ERR}(t_{nPARAM}),act$ exceed $t_{ERR}(t_{nPARAM}),allowed$, cycle time derating may be required for core timing parameters.

$$\text{CycleTimeDerating} = \max\left\{\left\{\frac{t_{PARAM} + t_{ERR}(t_{nPARAM}),act - t_{ERR}(t_{nPARAM}),allowed}{t_{nPARAM}} - t_{CK(avg)}\right\}, 0\right\}$$

Cycle time derating analysis should be conducted for each core timing parameter. The amount of cycle time derating required is the maximum of the cycle time deratings determined for each individual core timing parameter.

Clock Cycle Derating for Core Timing Parameters

For each core timing parameter and a given number of clocks (t_{nPARAM}), clock cycle derating should be specified with $t_{JIT(per)}$.

For a given number of clocks (t_{nPARAM}), when $t_{CK(avg)}$ plus $t_{ERR}(t_{nPARAM}),act$ exceed the supported cumulative $t_{ERR}(t_{nPARAM}),allowed$, derating is required. If the equation below results in a positive value for a core timing parameter (t_{CORE}), the required clock cycle derating will be that positive value (in clocks).

$$\text{ClockCycleDerating} = RU \left\{ \frac{t_{PARAM} + t_{ERR}(t_{nPARAM}),act - t_{ERR}(t_{nPARAM}),allowed}{t_{CK(avg)}} \right\} - t_{nPARAM}$$

Cycle-time derating analysis should be conducted for each core timing parameter.

Clock Jitter Effects on Command/Address Timing Parameters

Command/address timing parameters (t_{IS} , t_{IH} , t_{ISCKE} , t_{IHCKE} , t_{ISb} , t_{IHb} , t_{ISCKEb} , t_{IHCKEb}) are measured from a command/address signal (CKE, CS, or CA[9:0]) transition edge to its respective clock signal (CK/CK#) crossing. The specification values are not affected by the $t_{JIT(per)}$ applied, because the setup and hold times are relative to the clock signal crossing that latches the command/address. Regardless of clock jitter values, these values must be met.

Clock Jitter Effects on READ Timing Parameters

t_{RPRE}

When the device is operated with input clock jitter, t_{RPRE} must be derated by the $t_{JIT(per),act,max}$ of the input clock that exceeds $t_{JIT(per),allowed,max}$. Output deratings are relative to the input clock:

$$t_{RPRE}(min,derated) = 0.9 - \left(\frac{t_{JIT(per),act,max} - t_{JIT(per),allowed,max}}{t_{CK(avg)}} \right)$$

For example, if the measured jitter into a LPDDR2-800 device has $t_{CK(avg)} = 2500ps$, $t_{JIT(per),act,min} = -172ps$, and $t_{JIT(per),act,max} = +193ps$, then $t_{RPRE,min,derated} = 0.9 - (t_{JIT(per),act,max} - t_{JIT(per),allowed,max})/t_{CK(avg)} = 0.9 - (193 - 100)/2500 = 0.8628 t_{CK(avg)}$.

^tLZ(DQ), ^tHZ(DQ), ^tDQSCK, ^tLZ(DQS), ^tHZ(DQS)

These parameters are measured from a specific clock edge to a data signal transition (DM_n or DQ_m, where: *n* = 0, 1, 2, or 3; and *m* = DQ[31:0]), and specified timings must be met with respect to that clock edge. Therefore, they are not affected by ^tJIT(per).

^tQSH, ^tQSL

These parameters are affected by duty cycle jitter, represented by ^tCH(abs)min and ^tCL(abs)min. These parameters determine the absolute data valid window at the device pin. The absolute minimum data valid window at the device pin = min [(^tQSH(abs)min × ^tCK(avg)min - ^tDQSQmax - ^tQHSmax), (^tQSL(abs)min × ^tCK(avg)min - ^tDQSQmax - ^tQHSmax)]. This minimum data valid window must be met at the target frequency regardless of clock jitter.

^tRPST

^tRPST is affected by duty cycle jitter, represented by ^tCL(abs). Therefore, ^tRPST(abs)min can be specified by ^tCL(abs)min. ^tRPST(abs)min = ^tCL(abs)min - 0.05 = ^tQSL(abs)min.

Clock Jitter Effects on WRITE Timing Parameters

^tDS, ^tDH

These parameters are measured from a data signal (DM_n or DQ_m, where *n* = 0, 1, 2, 3; and *m* = DQ[31:0]) transition edge to its respective data strobe signal (DQS_n, DQS_n#; *n* = 0,1,2,3) crossing. The specification values are not affected by the amount of ^tJIT(per) applied, because the setup and hold times are relative to the clock signal crossing that latches the command/address. Regardless of clock jitter values, these values must be met.

^tDSS, ^tDSH

These parameters are measured from a data strobe signal crossing (DQS_x, DQS_x#) to its clock signal crossing (CK/CK#). The specification values are not affected by the amount of ^tJIT(per) applied, because the setup and hold times are relative to the clock signal crossing that latches the command/address. Regardless of clock jitter values, these values must be met.

^tDQSS

^tDQSS is measured from the clock signal crossing (CK/CK#) to the first latching data strobe signal crossing (DQS_x, DQS_x#). When the device is operated with input clock jitter, this parameter must be derated by the actual ^tJIT(per)_{act} of the input clock in excess of ^tJIT(per)_{allowed}.

$${}^tDQSS(\text{min,derated}) = 0.75 - \left(\frac{{}^tJIT(\text{per})_{\text{act,min}} - {}^tJIT(\text{per})_{\text{allowed,min}}}{{}^tCK(\text{avg})} \right)$$

$${}^tDQSS(\text{max,derated}) = 1.25 - \left(\frac{{}^tJIT(\text{per})_{\text{act,max}} - {}^tJIT(\text{per})_{\text{allowed,max}}}{{}^tCK(\text{avg})} \right)$$

For example, if the measured jitter into an LPDDR2-800 device has ^tCK(avg) = 2500ps, ^tJIT(per)_{act,min} = -172ps, and ^tJIT(per)_{act,max} = +193ps, then:

$${}^tDQSS(\text{min,derated}) = 0.75 - ({}^tJIT(\text{per})_{\text{act,min}} - {}^tJIT(\text{per})_{\text{allowed,min}}) / {}^tCK(\text{avg}) = 0.75 - (-172 + 100) / 2500 = 0.7788 \text{ } {}^tCK(\text{avg}), \text{ and}$$

$${}^tDQSS(\text{max,derated}) = 1.25 - ({}^tJIT(\text{per})_{\text{act,max}} - {}^tJIT(\text{per})_{\text{allowed,max}}) / {}^tCK(\text{avg}) =$$



$$1.25 - (193 - 100)/2500 = 1.2128 \text{ }^t\text{CK}(\text{avg}).$$

Refresh Requirements

Table 84: Refresh Requirement Parameters (Per Density)

Parameter	Symbol	64Mb	128Mb	256Mb	512Mb	1Gb	2Gb	4Gb	8Gb	Unit	
Number of banks		4	4	4	4	8	8	8	8		
Refresh window: $T_{\text{CASE}} \leq 85^\circ$	${}^t\text{REFW}$	32	32	32	32	32	32	32	32	ms	
Refresh window: $85^\circ\text{C} < T_{\text{CASE}} \leq 105^\circ\text{C}$	${}^t\text{REFW}$	8	8	8	8	8	8	8	8	ms	
Refresh window: $105^\circ\text{C} < T_{\text{CASE}} \leq 125^\circ\text{C}$	${}^t\text{REFW}$	8	8	8	8	8	8	8	8	ms	
Required number of REFRESH commands (MIN)	R	2048	2048	4096	4096	4096	8192	8192	8192		
Average time between REFRESH commands (for reference only) $T_{\text{CASE}} \leq 85^\circ\text{C}$	REFab	${}^t\text{REFI}$	15.6	15.6	7.8	7.8	7.8	3.9	3.9	3.9	μs
	REFpb	${}^t\text{REFIpb}$	(REFpb not supported below 1Gb)				0.975	0.4875	0.4875	0.4875	μs
Average time between REFRESH commands (for reference only) $85^\circ\text{C} < T_{\text{CASE}} \leq 105^\circ\text{C}$	REFab	${}^t\text{REFI}$	3.9	3.9	1.95	1.95	1.95	0.977	0.977	0.977	μs
	REFpb	${}^t\text{REFIpb}$	(REFpb not supported below 1Gb)				0.244	0.122	0.122	0.122	μs
Average time between REFRESH commands (for reference only) $105^\circ\text{C} < T_{\text{CASE}} \leq 125^\circ\text{C}$	REFab	${}^t\text{REFI}$	3.9	3.9	1.95	1.95	1.95	0.977	0.977	0.977	μs
	REFpb	${}^t\text{REFIpb}$	(REFpb not supported below 1Gb)				0.244	0.122	0.122	0.122	μs
Refresh cycle time	${}^t\text{RFCab}$	90	90	90	90	130	130	130	210	ns	
Per-bank REFRESH cycle time	${}^t\text{RFCpb}$	na					60	60	60	90	ns
Burst REFRESH window = $4 \times 8 \times {}^t\text{RFCab}$	${}^t\text{REFBW}$	2.88	2.88	2.88	2.88	4.16	4.16	4.16	6.72	μs	

AC Timing

Table 85: AC Timing

Notes 1–2 apply to all parameters and conditions. AC timing parameters must satisfy the t_{CK} minimum conditions (in multiples of t_{CK}) as well as the timing specifications when values for both are indicated.

Parameter	Symbol	Min/ Max	t_{CK} Min	Data Rate							Unit	Notes
				1066	933	800	667	533	400	333		
Maximum frequency		–	–	533	466	400	333	266	200	166	MHz	
Clock Timing												
Average clock period	$t_{CK(avg)}$	MIN	–	1.875	2.15	2.5	3	3.75	5	6	ns	
		MAX	–	100	100	100	100	100	100	100		
Average HIGH pulse width	$t_{CH(avg)}$	MIN	–	0.45	0.45	0.45	0.45	0.45	0.45	0.45	t_{CK} (avg)	
		MAX	–	0.55	0.55	0.55	0.55	0.55	0.55	0.55		
Average LOW pulse width	$t_{CL(avg)}$	MIN	–	0.45	0.45	0.45	0.45	0.45	0.45	0.45	t_{CK} (avg)	
		MAX	–	0.55	0.55	0.55	0.55	0.55	0.55	0.55		
Absolute clock period	$t_{CK(abs)}$	MIN	–	$t_{CK(avg)min} \pm t_{JIT(per)min}$							ps	
Absolute clock HIGH pulse width	$t_{CH(abs)}$	MIN	–	0.43	0.43	0.43	0.43	0.43	0.43	0.43	t_{CK} (avg)	
		MAX	–	0.57	0.57	0.57	0.57	0.57	0.57	0.57		
Absolute clock LOW pulse width	$t_{CL(abs)}$	MIN	–	0.43	0.43	0.43	0.43	0.43	0.43	0.43	t_{CK} (avg)	
		MAX	–	0.57	0.57	0.57	0.57	0.57	0.57	0.57		
Clock period jitter (with supported jitter)	$t_{JIT(per)}$, allowed	MIN	–	-90	-95	-100	-110	-120	-140	-150	ps	
		MAX	–	90	95	100	110	120	140	150		
Maximum clock jitter between two consecutive clock cycles (with supported jitter)	$t_{JIT(cc)}$, allowed	MAX	–	180	190	200	220	240	280	300	ps	
Duty cycle jitter (with supported jitter)	$t_{JIT(duty)}$, allowed	MIN	–	MIN ($(t_{CH(abs),min} - t_{CH(avg),min})$, $(t_{CL(abs),min} - t_{CL(avg),min}) \times t_{CK(avg)}$)							ps	
		MAX	–	MAX ($(t_{CH(abs),max} - t_{CH(avg),max})$, $(t_{CL(abs),max} - t_{CL(avg),max}) \times t_{CK(avg)}$)								
Cumulative errors across 2 cycles	$t_{ERR(2per)}$, allowed	MIN	–	-132	-140	-147	-162	-177	-206	-221	ps	
		MAX	–	132	140	147	162	177	206	221		
Cumulative errors across 3 cycles	$t_{ERR(3per)}$, allowed	MIN	–	-157	-166	-175	-192	-210	-245	-262	ps	
		MAX	–	157	166	175	192	210	245	262		
Cumulative errors across 4 cycles	$t_{ERR(4per)}$, allowed	MIN	–	-175	-185	-194	-214	-233	-272	-291	ps	
		MAX	–	175	185	194	214	233	272	291		
Cumulative errors across 5 cycles	$t_{ERR(5per)}$, allowed	MIN	–	-188	-199	-209	-230	-251	-293	-314	ps	
		MAX	–	188	199	209	230	251	293	314		
Cumulative errors across 6 cycles	$t_{ERR(6per)}$, allowed	MIN	–	-200	-211	-222	-244	-266	-311	-333	ps	
		MAX	–	200	211	222	244	266	311	333		
Cumulative errors across 7 cycles	$t_{ERR(7per)}$, allowed	MIN	–	-209	-221	-232	-256	-279	-325	-348	ps	
		MAX	–	209	221	232	256	279	325	348		

Table 85: AC Timing (Continued)

Notes 1–2 apply to all parameters and conditions. AC timing parameters must satisfy the t_{CK} minimum conditions (in multiples of t_{CK}) as well as the timing specifications when values for both are indicated.

Parameter	Symbol	Min/ Max	t_{CK} Min	Data Rate							Unit	Notes
				1066	933	800	667	533	400	333		
Cumulative errors across 8 cycles	$t_{ERR(8per)}$, allowed	MIN	–	-217	-229	-241	-266	-290	-338	-362	ps	
		MAX	–	217	229	241	266	290	338	362		
Cumulative errors across 9 cycles	$t_{ERR(9per)}$, allowed	MIN	–	-224	-237	-249	-274	-299	-349	-374	ps	
		MAX	–	224	237	249	274	299	349	374		
Cumulative errors across 10 cycles	$t_{ERR(10per)}$, allowed	MIN	–	-231	-244	-257	-282	-308	-359	-385	ps	
		MAX	–	231	244	257	282	308	359	385		
Cumulative errors across 11 cycles	$t_{ERR(11per)}$, allowed	MIN	–	-237	-250	-263	-289	-316	-368	-395	ps	
		MAX	–	237	250	263	289	316	368	395		
Cumulative errors across 12 cycles	$t_{ERR(12per)}$, allowed	MIN	–	-242	-256	-269	-296	-323	-377	-403	ps	
		MAX	–	242	256	269	296	323	377	403		
Cumulative errors across $n = 13, 14, 15 \dots, 49, 50$ cycles	$t_{ERR(nper)}$, allowed	MIN	$t_{ERR(nper),allowed,min} = (1 + 0.68\ln(n)) \times t_{JIT(per),allowed,min}$							ps		
		MAX	$t_{ERR(nper),allowed,max} = (1 + 0.68\ln(n)) \times t_{JIT(per),allowed,max}$									
ZQ Calibration Parameters												
Initialization calibration time	t_{ZQINIT}	MIN	–	1	1	1	1	1	1	1	μ s	
Long calibration time	t_{ZQCL}	MIN	6	360	360	360	360	360	360	360	ns	
Short calibration time	t_{ZQCS}	MIN	6	90	90	90	90	90	90	90	ns	
Calibration RESET time	$t_{ZQRESET}$	MIN	3	50	50	50	50	50	50	50	ns	
READ Parameters³												
DQS output access time from CK/CK#	t_{DQSCK}	MIN	–	2500	2500	2500	2500	2500	2500	2500	ps	
		MAX	–	5500	5500	5500	5500	5500	5500	5500		
DQSCK delta short	$t_{DQSCKDS}$	MAX	–	330	380	450	540	670	900	1080	ps	4
DQSCK delta medium	$t_{DQSCKDM}$	MAX	–	680	780	900	1050	1350	1800	1900	ps	5
DQSCK delta long	$t_{DQSCKDL}$	MAX	–	920	1050	1200	1400	1800	2400	–	ps	6
DQS-DQ skew	t_{DQSQ}	MAX	–	200	220	240	280	340	400	500	ps	
Data-hold skew factor	t_{QHS}	MAX	–	230	260	280	340	400	480	600	ps	
DQS output HIGH pulse width	t_{QSH}	MIN	–	$t_{CH(abs)} - 0.05$							t_{CK} (avg)	
DQS output LOW pulse width	t_{QSL}	MIN	–	$t_{CL(abs)} - 0.05$							t_{CK} (avg)	
Data half period	t_{QHP}	MIN	–	MIN (t_{QSH}, t_{QSL})							t_{CK} (avg)	
DQ/DQS output hold time from DQS	t_{QH}	MIN	–	$t_{QHP} - t_{QHS}$							ps	

Table 85: AC Timing (Continued)

Notes 1–2 apply to all parameters and conditions. AC timing parameters must satisfy the t_{CK} minimum conditions (in multiples of t_{CK}) as well as the timing specifications when values for both are indicated.

Parameter	Symbol	Min/ Max	t_{CK} Min	Data Rate							Unit	Notes
				1066	933	800	667	533	400	333		
READ preamble	t_{RPRE}	MIN	–	0.9	0.9	0.9	0.9	0.9	0.9	0.9	t_{CK} (avg)	7
READ postamble	t_{RPST}	MIN	–	$t_{CL(abs)} - 0.05$							t_{CK} (avg)	8
DQS Low-Z from clock	$t_{LZ(DQS)}$	MIN	–	$t_{DQSCK(MIN)} - 300$							ps	
DQ Low-Z from clock	$t_{LZ(DQ)}$	MIN	–	$t_{DQSCK(MIN)} - (1.4 \times t_{QHS(MAX)})$							ps	
DQS High-Z from clock	$t_{HZ(DQS)}$	MAX	–	$t_{DQSCK(MAX)} - 100$							ps	
DQ High-Z from clock	$t_{HZ(DQ)}$	MAX	–	$t_{DQSCK(MAX)} + (1.4 \times t_{DQSQ(MAX)})$							ps	
WRITE Parameters³												
DQ and DM input hold time (V_{REF} based)	t_{DH}	MIN	–	210	235	270	350	430	480	600	ps	
DQ and DM input setup time (V_{REF} based)	t_{DS}	MIN	–	210	235	270	350	430	480	600	ps	
DQ and DM input pulse width	t_{DIPW}	MIN	–	0.35	0.35	0.35	0.35	0.35	0.35	0.35	t_{CK} (avg)	
Write command to first DQS latching transition	t_{DQSS}	MIN	–	0.75	0.75	0.75	0.75	0.75	0.75	0.75	t_{CK} (avg)	
		MAX	–	1.25	1.25	1.25	1.25	1.25	1.25	1.25	t_{CK} (avg)	
DQS input high-level width	t_{DQSH}	MIN	–	0.4	0.4	0.4	0.4	0.4	0.4	0.4	t_{CK} (avg)	
DQS input low-level width	t_{DQSL}	MIN	–	0.4	0.4	0.4	0.4	0.4	0.4	0.4	t_{CK} (avg)	
DQS falling edge to CK setup time	t_{DSS}	MIN	–	0.2	0.2	0.2	0.2	0.2	0.2	0.2	t_{CK} (avg)	
DQS falling edge hold time from CK	t_{DSH}	MIN	–	0.2	0.2	0.2	0.2	0.2	0.2	0.2	t_{CK} (avg)	
Write postamble	t_{WPST}	MIN	–	0.4	0.4	0.4	0.4	0.4	0.4	0.4	t_{CK} (avg)	
Write preamble	t_{WPRE}	MIN	–	0.35	0.35	0.35	0.35	0.35	0.35	0.35	t_{CK} (avg)	
CKE Input Parameters												
CKE minimum pulse width (HIGH and LOW pulse width)	t_{CKE}	MIN	3	3	3	3	3	3	3	3	t_{CK} (avg)	
CKE input setup time	t_{ISCKE}	MIN	–	0.25	0.25	0.25	0.25	0.25	0.25	0.25	t_{CK} (avg)	9
CKE input hold time	t_{IHCKE}	MIN	–	0.25	0.25	0.25	0.25	0.25	0.25	0.25	t_{CK} (avg)	10

Table 85: AC Timing (Continued)

Notes 1–2 apply to all parameters and conditions. AC timing parameters must satisfy the t_{CK} minimum conditions (in multiples of t_{CK}) as well as the timing specifications when values for both are indicated.

Parameter	Symbol	Min/ Max	t_{CK} Min	Data Rate							Unit	Notes
				1066	933	800	667	533	400	333		
Command Address Input Parameters³												
Address and control input setup time	t_{IS}	MIN	–	220	250	290	370	460	600	740	ps	11
Address and control input hold time	t_{IH}	MIN	–	220	250	290	370	460	600	740	ps	11
Address and control input pulse width	t_{IPW}	MIN	–	0.40	0.40	0.40	0.40	0.40	0.40	0.40	t_{CK} (avg)	
Boot Parameters (10 MHz–55 MHz)^{12, 13, 14}												
Clock cycle time	t_{CKb}	MAX	–	100	100	100	100	100	100	100	ns	
		MIN	–	18	18	18	18	18	18	18		
CKE input setup time	t_{ISCKEb}	MIN	–	2.5	2.5	2.5	2.5	2.5	2.5	2.5	ns	
CKE input hold time	t_{IHCKEb}	MIN	–	2.5	2.5	2.5	2.5	2.5	2.5	2.5	ns	
Address and control input setup time	t_{ISb}	MIN	–	1150	1150	1150	1150	1150	1150	1150	ps	
Address and control input hold time	t_{IHb}	MIN	–	1150	1150	1150	1150	1150	1150	1150	ps	
DQS output data access time from CK/CK#	t_{DQSCKb}	MIN	–	2.0	2.0	2.0	2.0	2.0	2.0	2.0	ns	
		MAX	–	10.0	10.0	10.0	10.0	10.0	10.0	10.0		
Data strobe edge to output data edge	t_{DQSQb}	MAX	–	1.2	1.2	1.2	1.2	1.2	1.2	1.2	ns	
Data hold skew factor	t_{QHSb}	MAX	–	1.2	1.2	1.2	1.2	1.2	1.2	1.2	ns	
Mode Register Parameters												
MODE REGISTER WRITE command period	t_{MRW}	MIN	3	3	3	3	3	3	3	3	t_{CK} (avg)	
MODE REGISTER READ command period	t_{MRR}	MIN	2	2	2	2	2	2	2	2	t_{CK} (avg)	
Core Parameters¹⁵												
READ latency	RL	MIN	3	8	7	6	5	4	3	3	t_{CK} (avg)	
WRITE latency	WL	MIN	1	4	4	3	2	2	1	1	t_{CK} (avg)	
ACTIVATE-to-ACTIVATE command period	t_{RC}	MIN	–	$t_{RAS} + t_{RPab}$ (with all-bank precharge), $t_{RAS} + t_{RPpb}$ (with per-bank precharge)							ns	17
CKE minimum pulse width during SELF REFRESH (low pulse width during SELF REFRESH)	t_{CKESR}	MIN	3	15	15	15	15	15	15	15	ns	
SELF REFRESH exit to next valid command delay	t_{XSR}	MIN	2	$t_{RFCab} + 10$							ns	



Table 85: AC Timing (Continued)

Notes 1–2 apply to all parameters and conditions. AC timing parameters must satisfy the t_{CK} minimum conditions (in multiples of t_{CK}) as well as the timing specifications when values for both are indicated.

Parameter	Symbol	Min/ Max	t_{CK} Min	Data Rate							Unit	Notes	
				1066	933	800	667	533	400	333			
Exit power-down to next valid command delay	t_{XP}	MIN	2	7.5	7.5	7.5	7.5	7.5	7.5	7.5	ns		
CAS-to-CAS delay	t_{CCD}	MIN	2	2	2	2	2	2	2	2	t_{CK} (avg)		
Internal READ to PRECHARGE command delay	t_{RTP}	MIN	2	7.5	7.5	7.5	7.5	7.5	7.5	7.5	ns		
RAS-to-CAS delay	t_{RCD}	Fast	3	15	15	15	15	15	15	15	ns		
		TYP	3	18	18	18	18	18	18	18			
Row precharge time (single bank)	t_{RPpb}	Fast	3	15	15	15	15	15	15	15	ns		
		TYP	3	18	18	18	18	18	18	18			
Row precharge time (all banks)	t_{RPab} 4-bank	Fast	3	15	15	15	15	15	15	15	ns		
		TYP	3	18	18	18	18	18	18	18			
Row active time	t_{RAS}	MIN	3	42	42	42	42	42	42	42	ns		
		MAX	–	70	70	70	70	70	70	70	μ s		
WRITE recovery time	t_{WR}	MIN	3	15	15	15	15	15	15	15	ns		
Internal WRITE-to-READ command delay	t_{WTR}	MIN	2	7.5	7.5	7.5	7.5	7.5	10	10	ns		
Active bank <i>a</i> to active bank <i>b</i>	t_{RRD}	MIN	2	10	10	10	10	10	10	10	ns		
Four-bank activate window	t_{FAW}	MIN	8	50	50	50	50	50	50	60	ns		
Minimum deep power-down time	t_{DPD}	MIN	–	500	500	500	500	500	500	500	μ s		
Temperature Derating¹⁶													
t_{DQSCK} derating	t_{DQSCK} (derated)	MAX	–	5620	6000	6000	6000	6000	6000	6000	6000	ps	
Core timing temperature derating	t_{RCD} (derated)	MIN	–	$t_{RCD} + 1.875$							ns		
	t_{RC} (derated)	MIN	–	$t_{RC} + 1.875$							ns		
	t_{RAS} (derated)	MIN	–	$t_{RAS} + 1.875$							ns		
	t_{RP} (derated)	MIN	–	$t_{RP} + 1.875$							ns		
	t_{RRD} (derated)	MIN	–	$t_{RRD} + 1.875$							ns		

- Notes:
1. Frequency values are for reference only. Clock cycle time (t_{CK}) is used to determine device capabilities.
 2. All AC timings assume an input slew rate of 1 V/ns.
 3. READ, WRITE, and input setup and hold values are referenced to V_{REF} .

4. $t^{DQSCKDS}$ is the absolute value of the difference between any two t^{DQSCK} measurements (in a byte lane) within a contiguous sequence of bursts in a 160ns rolling window. $t^{DQSCKDS}$ is not tested and is guaranteed by design. Temperature drift in the system is $<10^{\circ}\text{C/s}$. Values do not include clock jitter.
5. $t^{DQSCKDM}$ is the absolute value of the difference between any two t^{DQSCK} measurements (in a byte lane) within a 1.6 μs rolling window. $t^{DQSCKDM}$ is not tested and is guaranteed by design. Temperature drift in the system is $<10^{\circ}\text{C/s}$. Values do not include clock jitter.
6. $t^{DQSCKDL}$ is the absolute value of the difference between any two t^{DQSCK} measurements (in a byte lane) within a 32ms rolling window. $t^{DQSCKDL}$ is not tested and is guaranteed by design. Temperature drift in the system is $<10^{\circ}\text{C/s}$. Values do not include clock jitter.

For LOW-to-HIGH and HIGH-to-LOW transitions, the timing reference is at the point when the signal crosses the transition threshold (V_{TT}). t^{HZ} and t^{LZ} transitions occur in the same access time (with respect to clock) as valid data transitions. These parameters are not referenced to a specific voltage level but to the time when the device output is no longer driving (for t^{RPST} , $t^{HZ(DQS)}$ and $t^{HZ(DQ)}$), or begins driving (for t^{RPRE} , $t^{LZ(DQS)}$, $t^{LZ(DQ)}$). The figure below shows a method to calculate the point when the device is no longer driving $t^{HZ(DQS)}$ and $t^{HZ(DQ)}$ or begins driving $t^{LZ(DQS)}$ and $t^{LZ(DQ)}$ by measuring the signal at two different voltages. The actual voltage measurement points are not critical as long as the calculation is consistent. The parameters $t^{LZ(DQS)}$, $t^{LZ(DQ)}$, $t^{HZ(DQS)}$, and $t^{HZ(DQ)}$ are defined as single-ended. The timing parameters t^{RPRE} and t^{RPST} are determined from the differential signal $DQS/DQS\#$.

Output Transition Timing

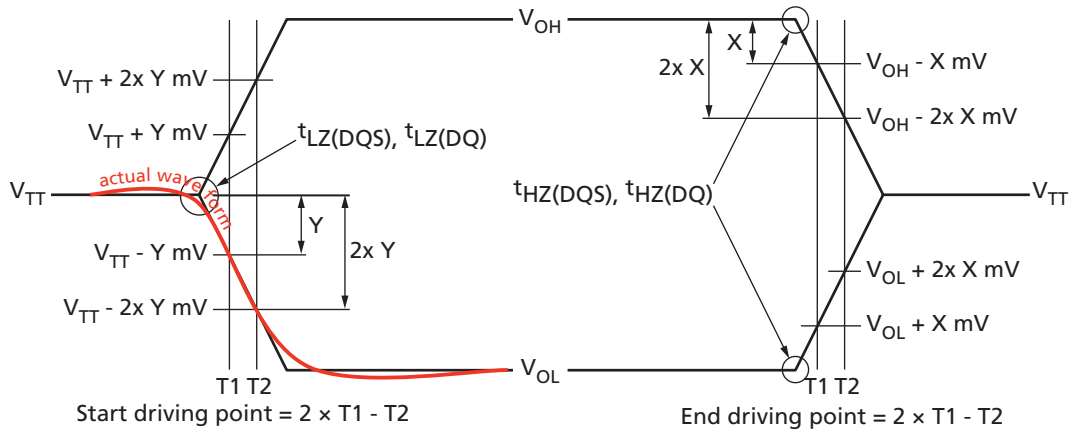

7. Measured from the point when $DQS/DQS\#$ begins driving the signal, to the point when $DQS/DQS\#$ begins driving the first rising strobe edge.
8. Measured from the last falling strobe edge of $DQS/DQS\#$ to the point when $DQS/DQS\#$ finishes driving the signal.
9. CKE input setup time is measured from CKE reaching a HIGH/LOW voltage level to $CK/CK\#$ crossing.
10. CKE input hold time is measured from $CK/CK\#$ crossing to CKE reaching a HIGH/LOW voltage level.
11. Input setup/hold time for signal (CA[9:0], CS#).
12. To ensure device operation before the device is configured, a number of AC boot timing parameters are defined in this table. The letter b is appended to the boot parameter symbols (for example, t^{CK} during boot is t^{CKb}).
13. Mobile LPDDR2 devices set some mode register default values upon receiving a $RESET$ (MRW) command, as specified in Mode Register Definition.

14. The output skew parameters are measured with default output impedance settings using the reference load.
15. The minimum t_{CK} column applies only when t_{CK} is greater than 6ns.
16. Timing derating applies for operation at 85°C to 105°C when the requirement to derate is indicated by mode register 4 op-code (see the MR4 Device Temperature (MA[7:0] = 04h) table).
17. DRAM devices should be evenly addressed when being accessed. Disproportionate accesses to a particular row address may result in reduction of the product lifetime.

Figure 78: Command Input Setup and Hold Timing

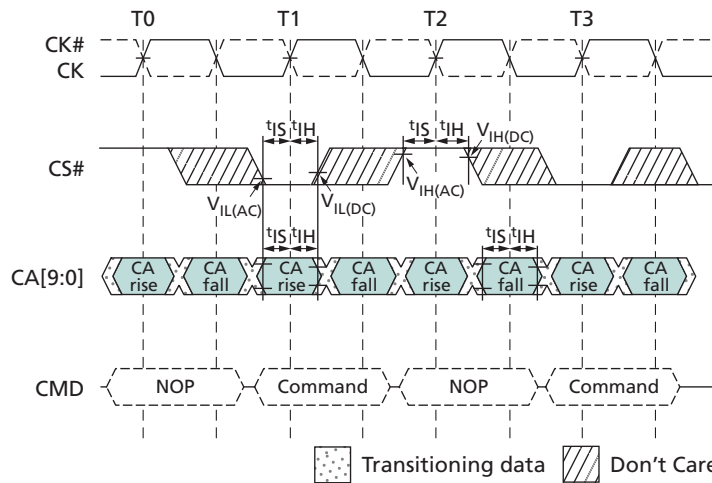

- Notes:
1. The setup and hold timing shown applies to all commands.
 2. Setup and hold conditions also apply to the CKE pin. For timing diagrams related to the CKE pin, see Power-Down (page 73).

CA and CS# Setup, Hold, and Derating

For all input signals (CA and CS#), the total required setup time (t^IS) and hold time (t^IH) is calculated by adding the data sheet t^IS (base) and t^IH (base) values to the Δt^IS and Δt^IH derating values, respectively. Example: t^IS (total setup time) = t^IS (base) + Δt^IS . (See the series of tables following this section.)

The typical setup slew rate (t^IS) for a rising signal is defined as the slew rate between the last crossing of $V_{REF(DC)}$ and the first crossing of $V_{IH(AC)min}$. The typical setup slew rate for a falling signal is defined as the slew rate between the last crossing of $V_{REF(DC)}$ and the first crossing of $V_{IL(AC)max}$. If the actual signal is consistently earlier than the typical slew rate line between the shaded $V_{REF(DC)}$ -to-(AC) region, use the typical slew rate for the derating value (see the Typical Slew Rate and $t^VAC - t^IS$ for CA and CS# Relative to Clock figure). If the actual signal is later than the typical slew rate line anywhere between the shaded $V_{REF(DC)}$ -to-AC region, the slew rate of a tangent line to the actual signal from the AC level to the DC level is used for the derating value (see the Tangent Line - t^IS for CA and CS# Relative to Clock figure).

The hold (t^IH) typical slew rate for a rising signal is defined as the slew rate between the last crossing of $V_{IL(DC)max}$ and the first crossing of $V_{REF(DC)}$. The hold (t^IH) typical slew rate for a falling signal is defined as the slew rate between the last crossing of $V_{IH(DC)min}$ and the first crossing of $V_{REF(DC)}$. If the actual signal is consistently later than the typical

slew rate line between the shaded DC-to- $V_{REF(DC)}$ region, use the typical slew rate for the derating value (see the Typical Slew Rate – t_{IH} for CA and CS# Relative to Clock figure). If the actual signal is earlier than the typical slew rate line anywhere between the shaded DC-to- $V_{REF(DC)}$ region, the slew rate of a tangent line to the actual signal from the DC level to $V_{REF(DC)}$ level is used for the derating value (see the Tangent Line – t_{IH} for CA and CS# Relative to Clock figure).

For a valid transition, the input signal must remain above or below $V_{IH}/V_{IL(AC)}$ for a specified time, t_{VAC} (see the Required Time for Valid Transition – $t_{VAC} > V_{IH(AC)}$ and $< V_{IL(AC)}$ table).

For slow slew rates the total setup time could be a negative value (that is, a valid input signal will not have reached $V_{IH}/V_{IL(AC)}$ at the time of the rising clock transition). A valid input signal is still required to complete the transition and reach $V_{IH}/V_{IL(AC)}$.

For slew rates between the values listed in the AC220 table, the derating values are obtained using linear interpolation. Slew rate values are not typically subject to production testing. They are verified by design and characterization.

Table 86: CA and CS# Setup and Hold Base Values (>400 MHz, 1 V/ns Slew Rate)

Parameter	Data Rate						Reference
	1066	933	800	667	533	466	
t_{IS} (base)	0	30	70	150	240	300	$V_{IH}/V_{IL(AC)} = V_{REF(DC)} \pm 220mV$
t_{IH} (base)	90	120	160	240	330	390	$V_{IH}/V_{IL(DC)} = V_{REF(DC)} \pm 130mV$

Note: 1. AC/DC referenced for 1 V/ns CA and CS# slew rate, and 2 V/ns differential CK/CK# slew rate.

Table 87: CA and CS# Setup and Hold Base Values (<400 MHz, 1 V/ns Slew Rate)

Parameter	Data Rate				Reference
	400	333	255	200	
t_{IS} (base)	300	440	600	850	$V_{IH}/V_{IL(AC)} = V_{REF(DC)} \pm 300mV$
t_{IH} (base)	400	540	700	950	$V_{IH}/V_{IL(DC)} = V_{REF(DC)} \pm 200mV$

Note: 1. AC/DC referenced for 1 V/ns CA and CS# slew rate, and 2 V/ns differential CK/CK# slew rate.



Table 88: Derating Values for AC/DC-Based t_{IS}/t_{IH} (AC220)

Δt_{IS} , Δt_{IH} derating in ps

		CK, CK# Differential Slew Rate															
		4.0 V/ns		3.0 V/ns		2.0 V/ns		1.8 V/ns		1.6 V/ns		1.4 V/ns		1.2 V/ns		1.0 V/ns	
		Δt_{IS}	Δt_{IH}	Δt_{IS}	Δt_{IH}	Δt_{IS}	Δt_{IH}	Δt_{IS}	Δt_{IH}	Δt_{IS}	Δt_{IH}	Δt_{IS}	Δt_{IH}	Δt_{IS}	Δt_{IH}	Δt_{IS}	Δt_{IH}
CA, CS# slew rate V/ns	2.0	110	65	110	65	110	65										
	1.5	74	43	73	43	73	43	89	59								
	1.0	0	0	0	0	0	0	16	16	32	32						
	0.9			-3	-5	-3	-5	13	11	29	27	45	43				
	0.8					-8	-13	8	3	24	19	40	35	56	55		
	0.7							2	-6	18	10	34	26	50	46	66	78
	0.6									10	-3	26	13	42	33	58	65
	0.5											4	-4	20	16	36	48
	0.4													-7	2	17	34

Note: 1. Shaded cells are not supported.

Table 89: Derating Values for AC/DC-Based t_{IS}/t_{IH} (AC300)

Δt_{IS} , Δt_{IH} derating in ps

		CK, CK# Differential Slew Rate															
		4.0 V/ns		3.0 V/ns		2.0 V/ns		1.8 V/ns		1.6 V/ns		1.4 V/ns		1.2 V/ns		1.0 V/ns	
		Δt_{IS}	Δt_{IH}	Δt_{IS}	Δt_{IH}	Δt_{IS}	Δt_{IH}	Δt_{IS}	Δt_{IH}	Δt_{IS}	Δt_{IH}	Δt_{IS}	Δt_{IH}	Δt_{IS}	Δt_{IH}	Δt_{IS}	Δt_{IH}
CA, CS# slew rate V/ns	2.0	150	100	150	100	150	100										
	1.5	100	67	100	67	100	67	116	83								
	1.0	0	0	0	0	0	0	16	16	32	32						
	0.9			-4	-8	-4	-8	12	8	28	24	44	40				
	0.8					-12	-20	4	-4	20	12	36	28	52	48		
	0.7							-3	-18	13	-2	29	14	45	34	61	66
	0.6									2	-21	18	-5	34	15	50	47
	0.5											-12	-32	4	-12	20	20
	0.4													-35	-40	-11	-8

Note: 1. Shaded cells are not supported.

Table 90: Required Time for Valid Transition – $t_{VAC} > V_{IH(AC)}$ and $< V_{IL(AC)}$

Slew Rate (V/ns)	t_{VAC} at 300mV (ps)		t_{VAC} at 220mV (ps)	
	Min	Max	Min	Max
>2.0	75	–	175	–
2.0	57	–	170	–
1.5	50	–	167	–
1.0	38	–	163	–

Table 90: Required Time for Valid Transition – $t_{VAC} > V_{IH(AC)}$ and $< V_{IL(AC)}$ (Continued)

Slew Rate (V/ns)	t_{VAC} at 300mV (ps)		t_{VAC} at 220mV (ps)	
	Min	Max	Min	Max
0.9	34	–	162	–
0.8	29	–	161	–
0.7	22	–	159	–
0.6	13	–	155	–
0.5	0	–	150	–
<0.5	0	–	150	–

Figure 79: Typical Slew Rate and $t_{VAC} - t_{IS}$ for CA and CS# Relative to Clock

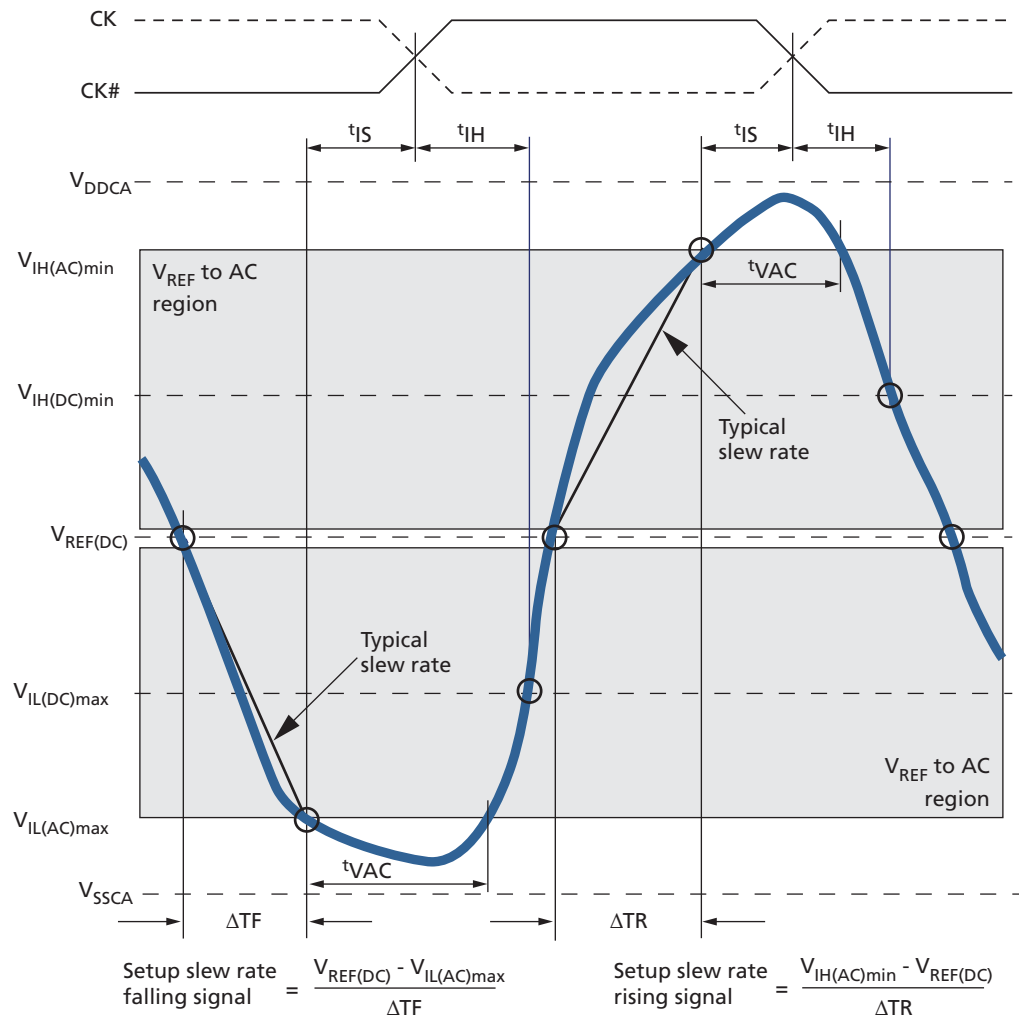

Figure 80: Typical Slew Rate – t_{IH} for CA and CS# Relative to Clock

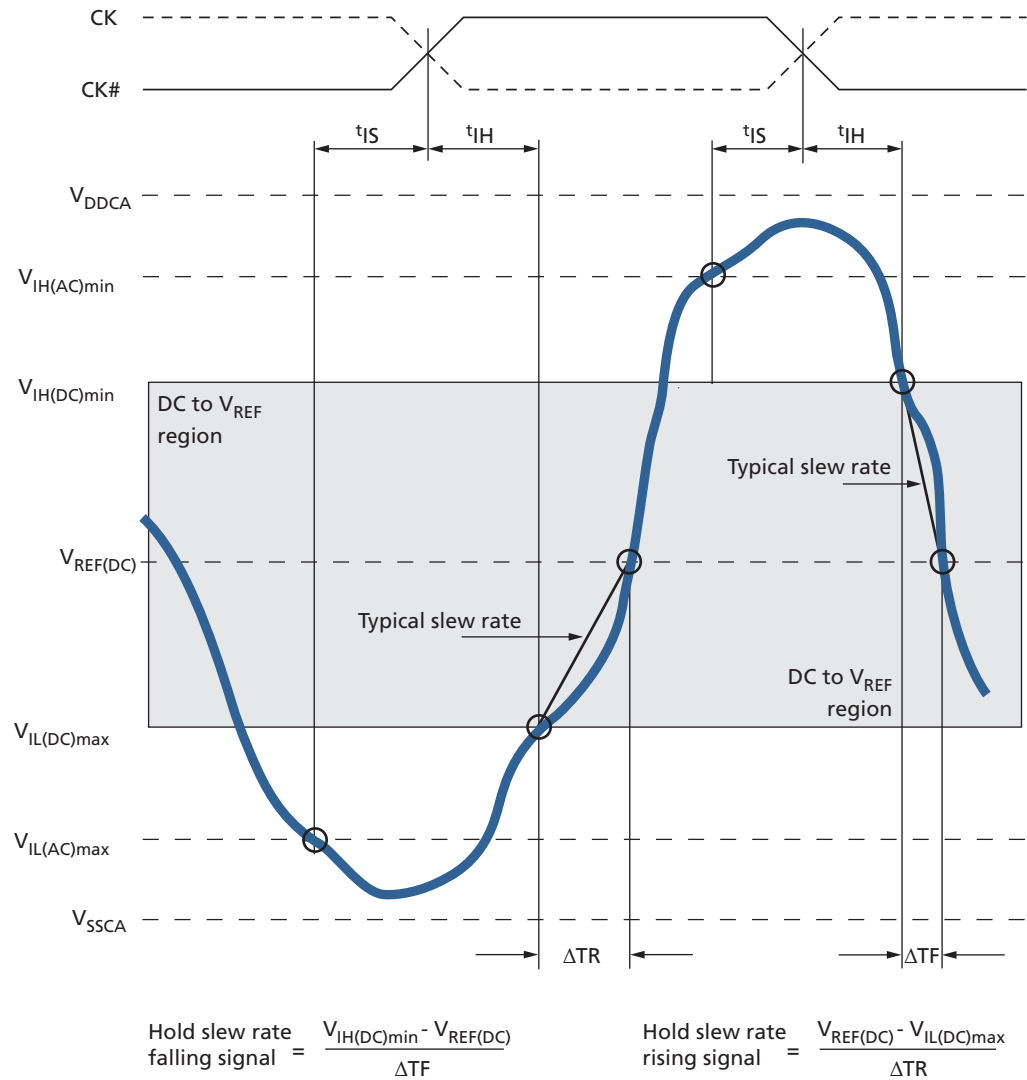

Figure 81: Tangent Line – t_{IS} for CA and CS# Relative to Clock

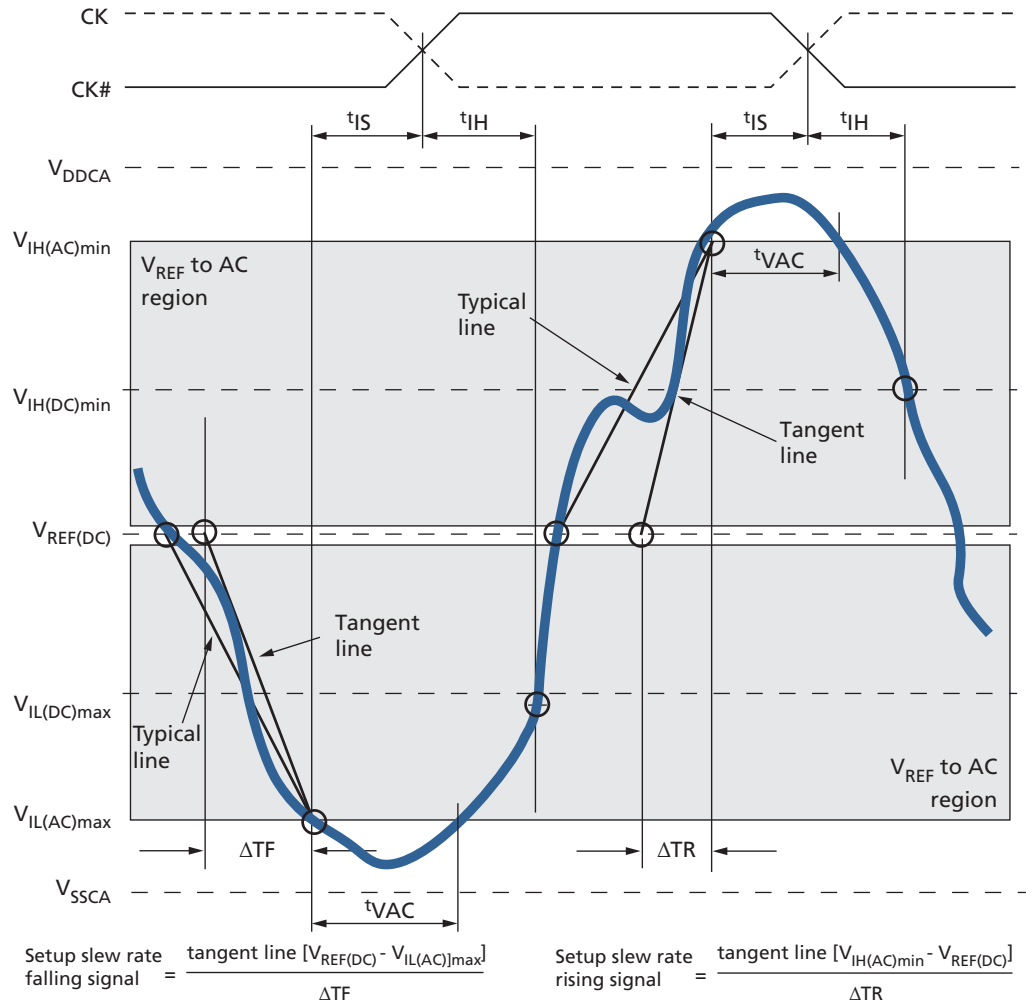
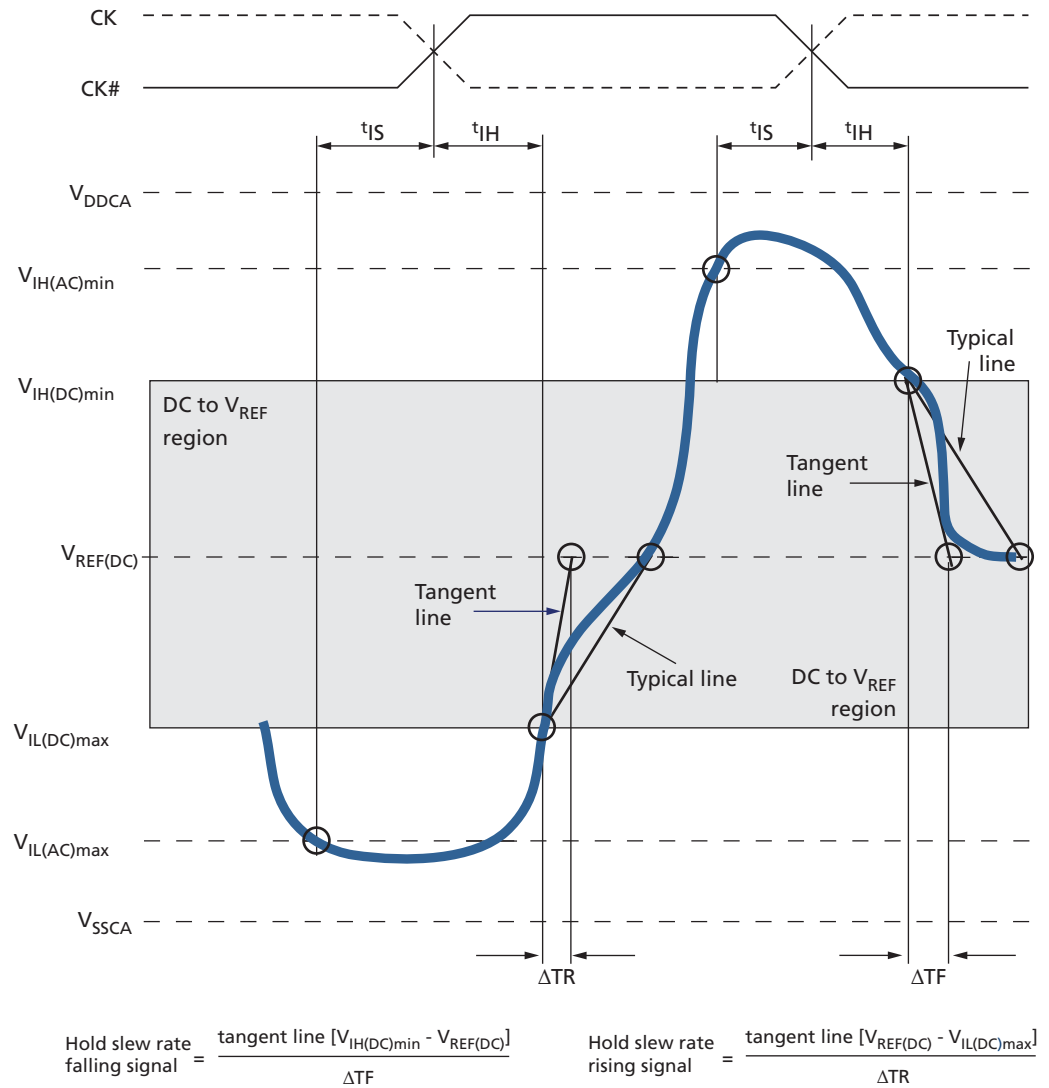

Figure 82: Tangent Line – t_{IH} for CA and CS# Relative to Clock



Data Setup, Hold, and Slew Rate Derating

For all input signals (DQ, DM) calculate the total required setup time (t_{DS}) and hold time (t_{DH}) by adding the data sheet $t_{DS}(\text{base})$ and $t_{DH}(\text{base})$ values (see the following table) to the Δt_{DS} and Δt_{DH} derating values, respectively (see the following derating tables). Example: $t_{DS} = t_{DS}(\text{base}) + \Delta t_{DS}$.

The typical t_{DS} slew rate for a rising signal is defined as the slew rate between the last crossing of $V_{REF(DC)}$ and the first crossing of $V_{IH(AC)min}$. The typical t_{DS} slew rate for a falling signal is defined as the slew rate between the last crossing of $V_{REF(DC)}$ and the first crossing of $V_{IL(AC)max}$ (see the Typical Slew Rate and $t_{VAC} - t_{DS}$ for DQ Relative to Strobe figure).

If the actual signal is consistently earlier than the typical slew rate line in the figure, "Typical Slew Rate and $t_{VAC} - t_{IS}$ for CA and CS# Relative to Clock (CA and CS# Setup, Hold, and Derating), the area shaded gray between the $V_{REF(DC)}$ region and the AC region, use the typical slew rate for the derating value. If the actual signal is later than the typical slew rate line anywhere between the shaded $V_{REF(DC)}$ region and the AC region, the slew rate of a tangent line to the actual signal from the AC level to the DC level is used for the derating value (see figure "Tangent Line - t_{IS} for CA and CS# Relative to Clock" in CA and CS# Setup, Hold, and Derating).

The typical t_{DH} slew rate for a rising signal is defined as the slew rate between the last crossing of $V_{IL(DC)max}$ and the first crossing of $V_{REF(DC)}$. The typical t_{DH} slew rate for a falling signal is defined as the slew rate between the last crossing of $V_{IH(DC)min}$ and the first crossing of $V_{REF(DC)}$ (see the Typical Slew Rate - DH for DQ Relative to Strobe figure).

If the actual signal is consistently later than the typical slew rate line between the shaded DC-level-to- $V_{REF(DC)}$ region, use the typical slew rate for the derating value. If the actual signal is earlier than the typical slew rate line anywhere between shaded DC-to- $V_{REF(DC)}$ region, the slew rate of a tangent line to the actual signal from the DC level to the $V_{REF(DC)}$ level is used for the derating value (see the Tangent Line - t_{DH} for DQ with Respect to Strobe figure).

For a valid transition, the input signal must remain above or below $V_{IH}/V_{IL(AC)}$ for the specified time, t_{VAC} (see the Required Time for Valid Transition - $t_{VAC} > V_{IH(AC)}$ or $< V_{IL(AC)}$ table).

The total setup time for slow slew rates could be negative (that is, a valid input signal may not have reached $V_{IH}/V_{IL(AC)}$ at the time of the rising clock transition). A valid input signal is still required to complete the transition and reach $V_{IH}/V_{IL(AC)}$.

For slew rates between the values listed in the following tables, the derating values can be obtained using linear interpolation. Slew rate values are not typically subject to production testing. They are verified by design and characterization.

Table 91: Data Setup and Hold Base Values (>400 MHz, 1 V/ns Slew Rate)

Parameter	Data Rate						Reference
	1066	933	800	667	533	466	
$t_{DS}(\text{base})$	-10	15	50	130	210	230	$V_{IH}/V_{IL(AC)} = V_{REF(DC)} \pm 220\text{mV}$



512Mb: x32 Automotive Mobile LPDDR2 SDRAM Data Setup, Hold, and Slew Rate Derating

Table 91: Data Setup and Hold Base Values (>400 MHz, 1 V/ns Slew Rate) (Continued)

Parameter	Data Rate						Reference
	1066	933	800	667	533	466	
t [†] DH (base)	80	105	140	220	300	320	V _{IH} /V _{IL(DC)} = V _{REF(DC)} ±130mV

Note: 1. AC/DC referenced for 1 V/ns DQ, DM slew rate, and 2 V/ns differential DQS/DQS# slew rate.

Table 92: Data Setup and Hold Base Values (<400 MHz, 1 V/ns Slew Rate)

Parameter	Data Rate				Reference
	400	333	255	200	
t [†] DS (base)	180	300	450	700	V _{IH} /V _{IL(AC)} = V _{REF(DC)} ±300mV
t [†] DH (base)	280	400	550	800	V _{IH} /V _{IL(DC)} = V _{REF(DC)} ±200mV

Note: 1. AC/DC referenced for 1 V/ns DQ, DM slew rate, and 2 V/ns differential DQS/DQS# slew rate.

Table 93: Derating Values for AC/DC-Based t[†]DS/t[†]DH (AC220)

Δt[†]DS, Δt[†]DH derating in ps

		DQS, DQS# Differential Slew Rate															
		4.0 V/ns		3.0 V/ns		2.0 V/ns		1.8 V/ns		1.6 V/ns		1.4 V/ns		1.2 V/ns		1.0 V/ns	
		Δt [†] DS	Δt [†] DH	Δt [†] DS	Δt [†] DH	Δt [†] DS	Δt [†] DH	Δt [†] DS	Δt [†] DH	Δt [†] DS	Δt [†] DH	Δt [†] DS	Δt [†] DH	Δt [†] DS	Δt [†] DH	Δt [†] DS	Δt [†] DH
DQ, DM slew rate V/ns	2.0	110	65	110	65	110	65										
	1.5	74	43	73	43	73	43	89	59								
	1.0	0	0	0	0	0	0	16	16	32	32						
	0.9			-3	-5	-3	-5	13	11	29	27	45	43				
	0.8					-8	-13	8	3	24	19	40	35	56	55		
	0.7							2	-6	18	10	34	26	50	46	66	78
	0.6									10	-3	26	13	42	33	58	65
	0.5											4	-4	20	16	36	48
	0.4													-7	2	17	34

Note: 1. Shaded cells are not supported.



Table 94: Derating Values for AC/DC-Based t_{DS}/t_{DH} (AC300)

Δt_{DS} , Δt_{DH} derating in ps

		DQS, DQS# Differential Slew Rate															
		4.0 V/ns		3.0 V/ns		2.0 V/ns		1.8 V/ns		1.6 V/ns		1.4 V/ns		1.2 V/ns		1.0 V/ns	
		Δt_{DS}	Δt_{DH}	Δt_{DS}	Δt_{DH}	Δt_{DS}	Δt_{DH}	Δt_{DS}	Δt_{DH}	Δt_{DS}	Δt_{DH}	Δt_{DS}	Δt_{DH}	Δt_{DS}	Δt_{DH}	Δt_{DS}	Δt_{DH}
DQ, DM slew rate V/ns	2.0	150	100	150	100	150	100										
	1.5	100	67	100	67	100	67	116	83								
	1.0	0	0	0	0	0	0	16	16	32	32						
	0.9			-4	-8	-4	-8	12	8	28	24	44	40				
	0.8					-12	-20	4	-4	20	12	36	28	52	48		
	0.7							-3	-18	13	-2	29	14	45	34	61	66
	0.6									2	-21	18	-5	34	15	50	47
	0.5											-12	-32	4	-12	20	20
	0.4												4	-35	-40	-11	-8

Note: 1. Shaded cells are not supported.

Table 95: Required Time for Valid Transition – $t_{VAC} > V_{IH(AC)}$ or $< V_{IL(AC)}$

Slew Rate (V/ns)	t_{VAC} at 300mV (ps)		t_{VAC} at 220mV (ps)	
	Min	Max	Min	Max
>2.0	75	–	175	–
2.0	57	–	170	–
1.5	50	–	167	–
1.0	38	–	163	–
0.9	34	–	162	–
0.8	29	–	161	–
0.7	22	–	159	–
0.6	13	–	155	–
0.5	0	–	150	–
<0.5	0	–	150	–

Figure 83: Typical Slew Rate and $t_{VAC} - t_{DS}$ for DQ Relative to Strobe

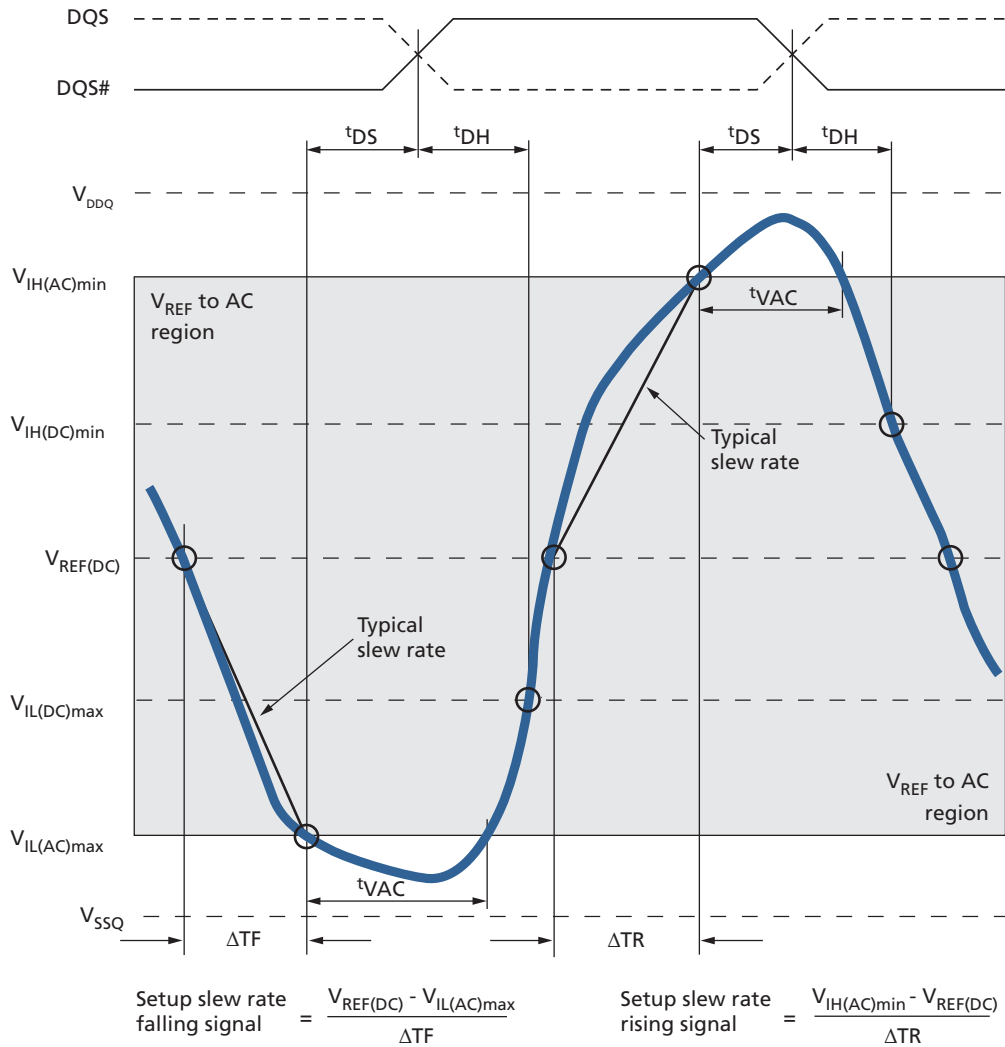

Figure 84: Typical Slew Rate – t_{DH} for DQ Relative to Strobe

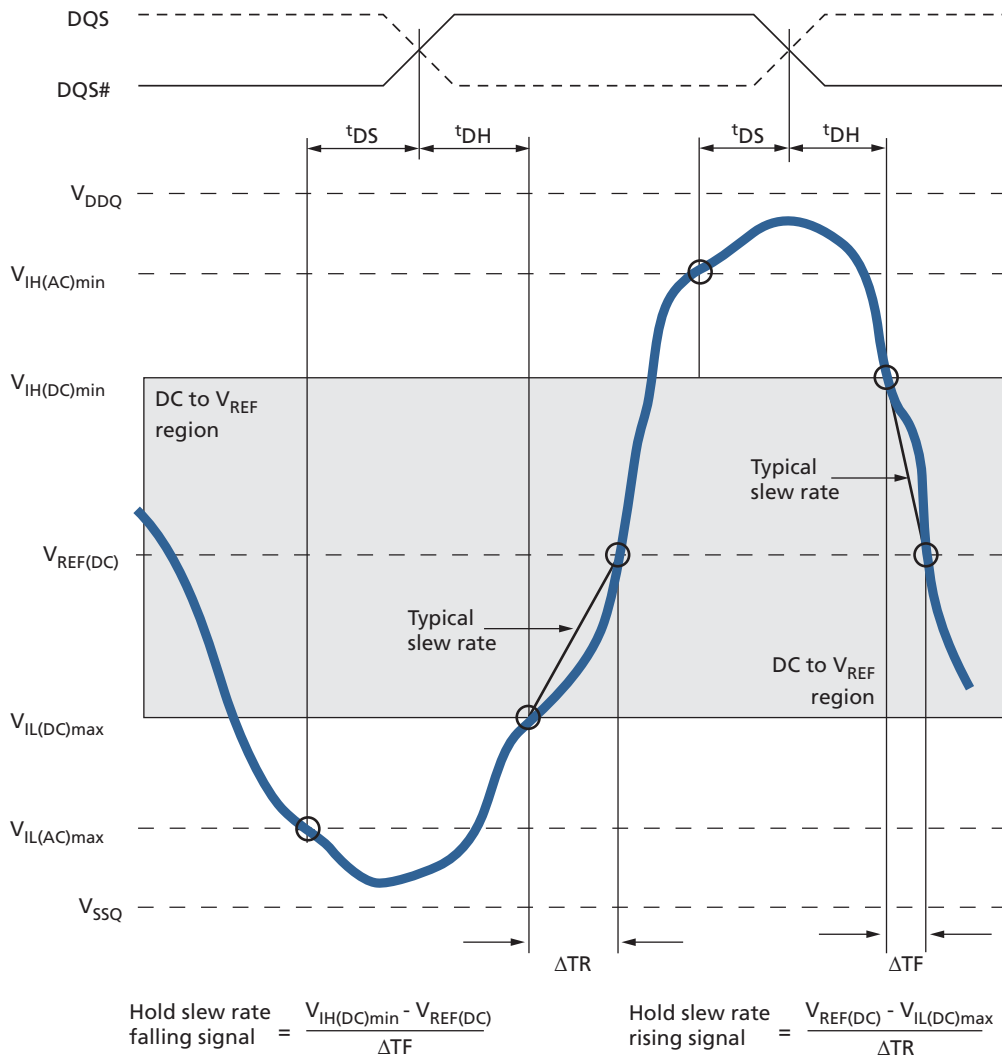

Figure 85: Tangent Line – t_{DS} for DQ with Respect to Strobe

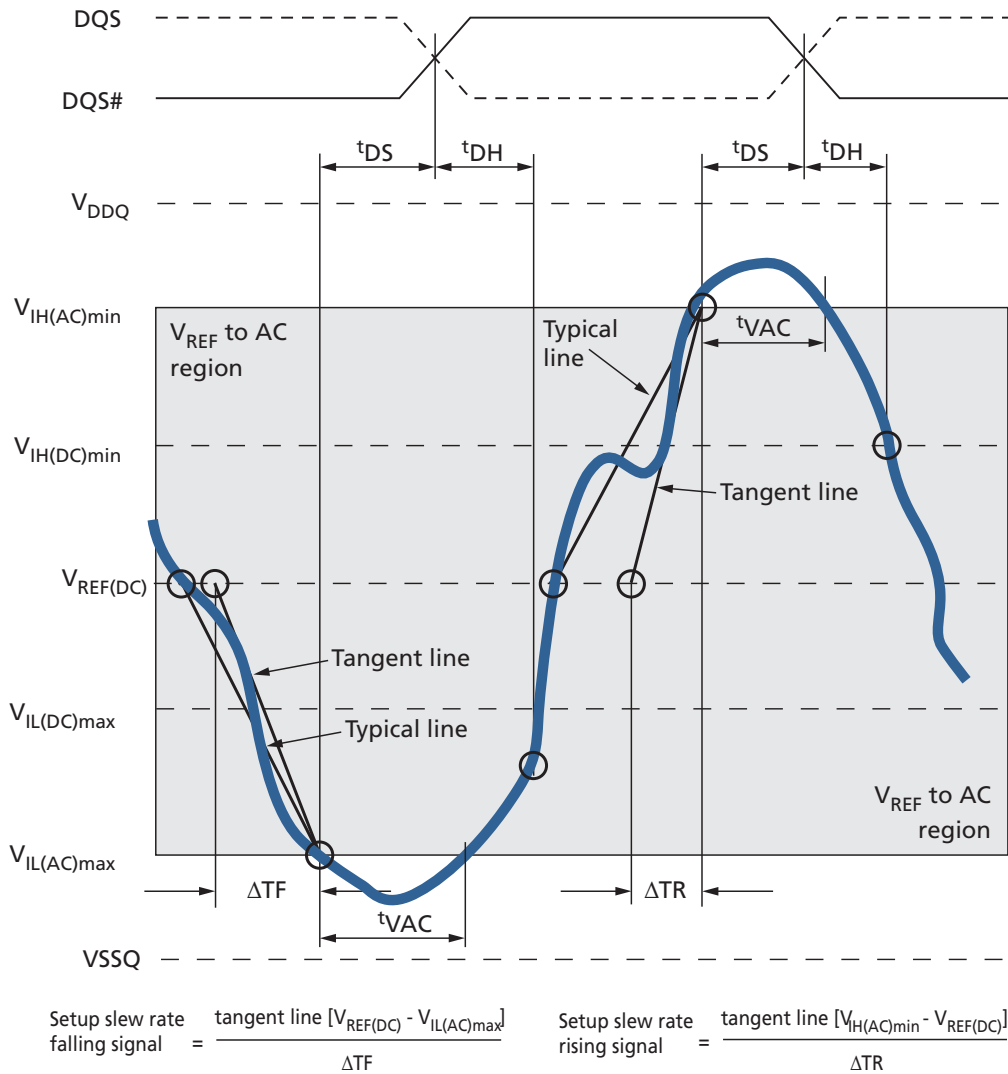
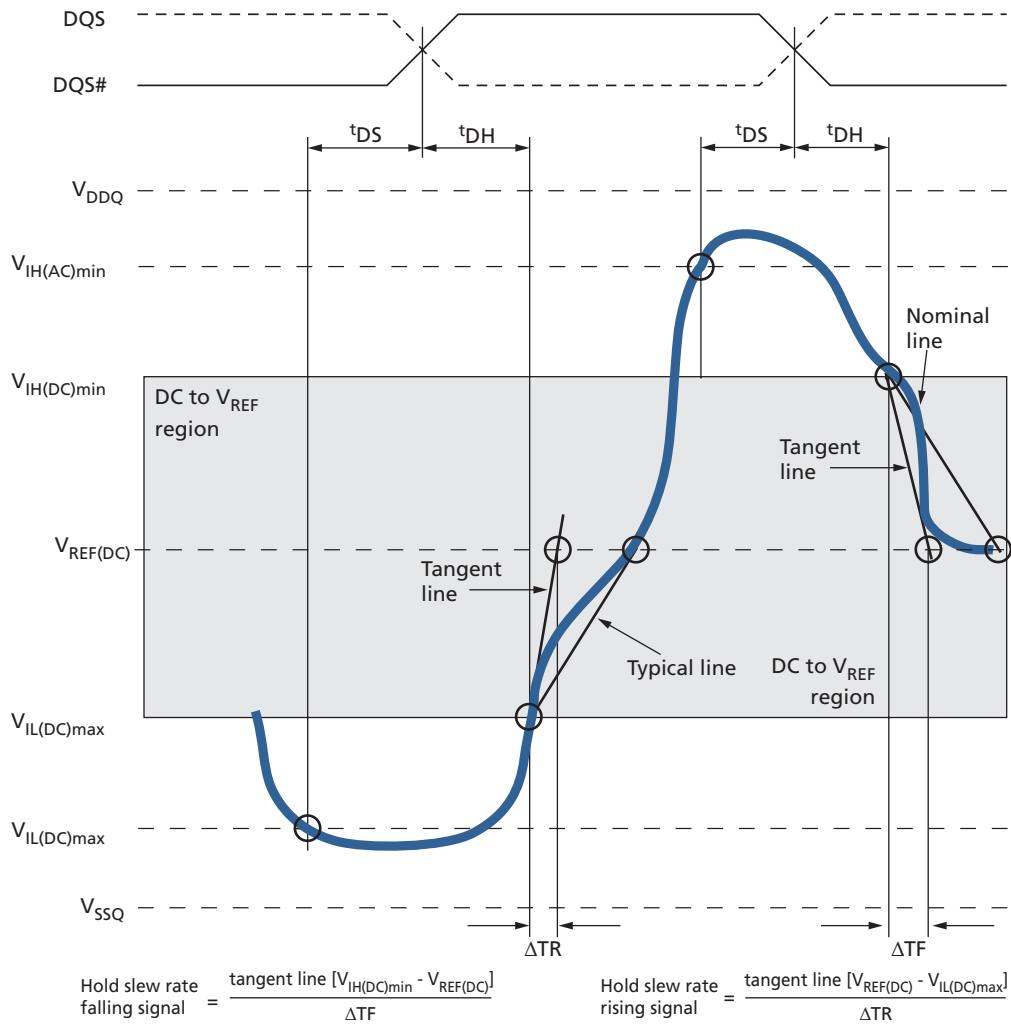

Figure 86: Tangent Line – t_{DH} for DQ with Respect to Strobe



Revision History

Rev. D – 01/16

- Typo correction in 512Mb LPDDR2 Part Numbering figure in Feature

Rev. C – 12/15

- Updated I_{DD6} Partial-Array Self Refresh Current table in I_{DD} Specifications section
- Added note about V_{DDCA} pin treatment for 134-Ball VFPGA and 168-Ball WFBGA in Ball Assignments and Descriptions section

Rev. B – 10/15

- Added I_{ddx} values, and refresh requirements for AUT option.

Rev. A – 07/15

- Initial release
- Used LPDDR2 U87M 512mb_mobile_lpddr2_u87n_ait_aat.pdf as basis; Rev B, published 2/15 (PDF: 09005aef85fcf570)

8000 S. Federal Way, P.O. Box 6, Boise, ID 83707-0006, Tel: 208-368-4000
www.micron.com/products/support Sales inquiries: 800-932-4992
Micron and the Micron logo are trademarks of Micron Technology, Inc.
All other trademarks are the property of their respective owners.

This data sheet contains minimum and maximum limits specified over the power supply and temperature range set forth herein. Although considered final, these specifications are subject to change, as further product development and data characterization sometimes occur.

Looking for pricing, stock, or lifecycle information?

Click below to explore more details on WIN SOURCE:

- ⊖ [View EDB5432BEBH-1DAAT-F-D on WIN SOURCE](#)
- ⊖ [Micron Technology Inc. Information](#)

Optimize Your Supply Chain with WIN SOURCE Solutions

- ✓ Global Sourcing Solution
- ✓ Obsolete Management
- ✓ Cost Control Management
- ✓ Shortage Management
- ✓ Alternative Solution
- ✓ Excess Inventory Management