



**THE DATASHEET OF  
BGS12PL6E6327XTSA1**



# BGS12PL6

General purpose RF CMOS power SPDT Switch  
in ultra small package with 0.77mm<sup>2</sup> footprint

## Data Sheet

Revision 2.5, 2015-04-08

**Edition April 8, 2015**

**Published by  
Infineon Technologies AG  
81726 Munich, Germany**

**©2012 Infineon Technologies AG  
All Rights Reserved.**

### **Legal Disclaimer**

The information given in this document shall in no event be regarded as a guarantee of conditions or characteristics. With respect to any examples or hints given herein, any typical values stated herein and/or any information regarding the application of the device, Infineon Technologies hereby disclaims any and all warranties and liabilities of any kind, including without limitation, warranties of non-infringement of intellectual property rights of any third party.

### **Information**

For further information on technology, delivery terms and conditions and prices, please contact the nearest Infineon Technologies Office ([www.infineon.com](http://www.infineon.com)).

### **Warnings**

Due to technical requirements, components may contain dangerous substances. For information on the types in question, please contact the nearest Infineon Technologies Office.

Infineon Technologies components may be used in life-support devices or systems only with the express written approval of Infineon Technologies, if a failure of such components can reasonably be expected to cause the failure of that life-support device or system or to affect the safety or effectiveness of that device or system. Life support devices or systems are intended to be implanted in the human body or to support and/or maintain and sustain and/or protect human life. If they fail, it is reasonable to assume that the health of the user or other persons may be endangered.

## Revision History

**Document No.:** BGS12PL6.pdf

**Previous Version:** v2.4, May 27, 2014

Page	Subjects (major changes since last revision)
7	Updated Features
9	Updated Operation Ranges

### Trademarks of Infineon Technologies AG

AURIX™, C166™, CanPAK™, CIPOS™, CIPURSE™, CoolGaN™, CoolMOS™, CoolSET™, CoolSiC™, CORECONTROL™, DAVE™, DI-POL™, EasyPIM™, EconoBRIDGE™, EconoDUAL™, EconoPACK™, EconoPIM™, EiceDRIVER™, eupec™, FCOS™, HITFET™, HybridPACK™, ISOFACE™, I<sup>2</sup>RF™, IsoPACK™, MIPAQ™, ModSTACK™, my-d™, NovalithIC™, OmniTune™, OptiMOS™, ORIGA™, OPTIGA™, PROFET™, PRO-SIL™, PRIMARION™, PrimePACK™, RASIC™, ReverSave™, SatRIC™, SIEGET™, SIPMOS™, SOLID FLASH™, SmartLEWIS™, TEMPFET™, thinQ!™, TriCore™, TRENCHSTOP™.

### Other Trademarks

Advance Design System™ (ADS) of Agilent Technologies, AMBA™, ARM™, MULTI-ICE™, PRIMECELL™, REALVIEW™, THUMB™ of ARM Limited, UK. AUTOSAR™ is licensed by AUTOSAR development partnership. Bluetooth™ of Bluetooth SIG Inc. CAT-iq™ of DECT Forum. COLOSSUS™, FirstGPS™ of Trimble Navigation Ltd. EMV™ of EMVCo, LLC (Visa Holdings Inc.). EPCOS™ of Epcos AG. FLEXGO™ of Microsoft Corporation. FlexRay™ is licensed by FlexRay Consortium. HYPERTERMINAL™ of Hilgraeve Incorporated. IEC™ of Commission Electrotechnique Internationale. IrDA™ of Infrared Data Association Corporation. ISO™ of INTERNATIONAL ORGANIZATION FOR STANDARDIZATION. MATLAB™ of MathWorks, Inc. MAXIM™ of Maxim Integrated Products, Inc. MICROTEC™, NUCLEUS™ of Mentor Graphics Corporation. Mifare™ of NXP. MIPI™ of MIPI Alliance, Inc. MIPS™ of MIPS Technologies, Inc., USA. muRata™ of MURATA MANUFACTURING CO., MICROWAVE OFFICE™ (MWO) of Applied Wave Research Inc., OmniVision™ of OmniVision Technologies, Inc. Openwave™ Openwave Systems Inc. RED HAT™ Red Hat, Inc. RFMD™ RF Micro Devices, Inc. SIRIUS™ of Sirius Sattelite Radio Inc. SOLARIS™ of Sun Microsystems, Inc. SPANSION™ of Spansion LLC Ltd. Symbian™ of Symbian Software Limited. TAIYO YUDEN™ of Taiyo Yuden Co. TEAKLITE™ of CEVA, Inc. TEKTRONIX™ of Tektronix Inc. TOKO™ of TOKO KABUSHIKI KAISHA TA. UNIX™ of X/Open Company Limited. VERILOG™, PALLADIUM™ of Cadence Design Systems, Inc. VLYNQ™ of Texas Instruments Incorporated. VXWORKS™, WIND RIVER™ of WIND RIVER SYSTEMS, INC. ZETEX™ of Diodes Zetex Limited.

Last Trademarks Update 2012-12-13

## Contents

<b>1 Features</b>	<b>7</b>
<b>2 Product Description</b>	<b>7</b>
<b>3 Maximum Ratings</b>	<b>9</b>
<b>4 Operation Ranges</b>	<b>9</b>
<b>5 RF Characteristics</b>	<b>10</b>
<b>6 Pin Description</b>	<b>12</b>
<b>7 Package Information</b>	<b>12</b>

## List of Figures

1	BGS12PL6 Block Diagram . . . . .	8
2	Pin Configuration . . . . .	12
3	Package Outline . . . . .	13
4	Footprint . . . . .	13
5	Pin 1 Marking (top view) . . . . .	13
6	Tape Drawing for TSLP-6-4 . . . . .	14

## List of Tables

1	Ordering Information . . . . .	7
2	Truth Table . . . . .	8
3	Maximum Ratings . . . . .	9
4	Operation Ranges . . . . .	9
5	RF Input Power . . . . .	9
6	RF Characteristics . . . . .	10
7	Pin Description . . . . .	12
8	Mechanical Data . . . . .	12

## BGS12PL6 General purpose RF CMOS power SPDT Switch in ultra small package with 0.77mm<sup>2</sup> footprint

### 1 Features

- 2 high-linearity TRx paths with power handling capability of up to 35 dBm
- All ports fully symmetrical
- Low insertion loss
- Low harmonic generation
- High port-to-port isolation
- 30 MHz to 4 GHz coverage
- High ESD robustness
- On-chip control logic
- Very small leadless and halogen free package TSLP-6-4 (0.7x1.1mm<sup>2</sup>) with super low height of 0.31 mm
- No decoupling capacitors required if no DC applied on RF lines
- RoHS compliant package

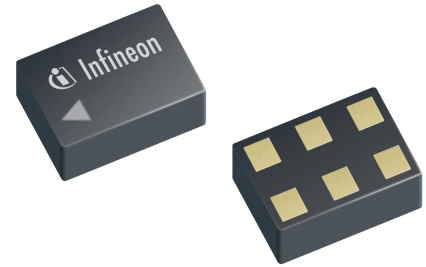

### 2 Product Description

The BGS12PL6 general purpose RF MOS power switch is designed to cover a broad range of high power applications from 30 MHz to 4 GHz, mainly in the transmit path of GSM, WCDMA and LTE mobile phones. The symmetric design of its single pole double throw configuration, as shown in Figure 1 offers high design flexibility.

This single supply chip integrates on-chip CMOS logic driven by a simple, single-pin CMOS or TTL compatible control input signal. The 0.1 dB compression point exceeds the switch's maximum input power level of 35 dBm, resulting in linear performance at all signal levels. The RF switch has a very low insertion loss of 0.36 dB in the 1 GHz, 0.46 dB in the 2 GHz and 0.6 dB in the 3 GHz range.

The BGS12PL6 RF switch is manufactured in Infineon's patented MOS technology, offering the performance of GaAs with the economy and integration of conventional CMOS including the inherent higher ESD robustness.

The device has a very small size of only 0.7x 1.1mm<sup>2</sup> and a low height of 0.31mm. No decoupling capacitors are required in typical applications as long as no DC is applied to any RF port.

**Table 1: Ordering Information**

Type	Package	Marking
BGS12PL6	TSLP-6-4	P

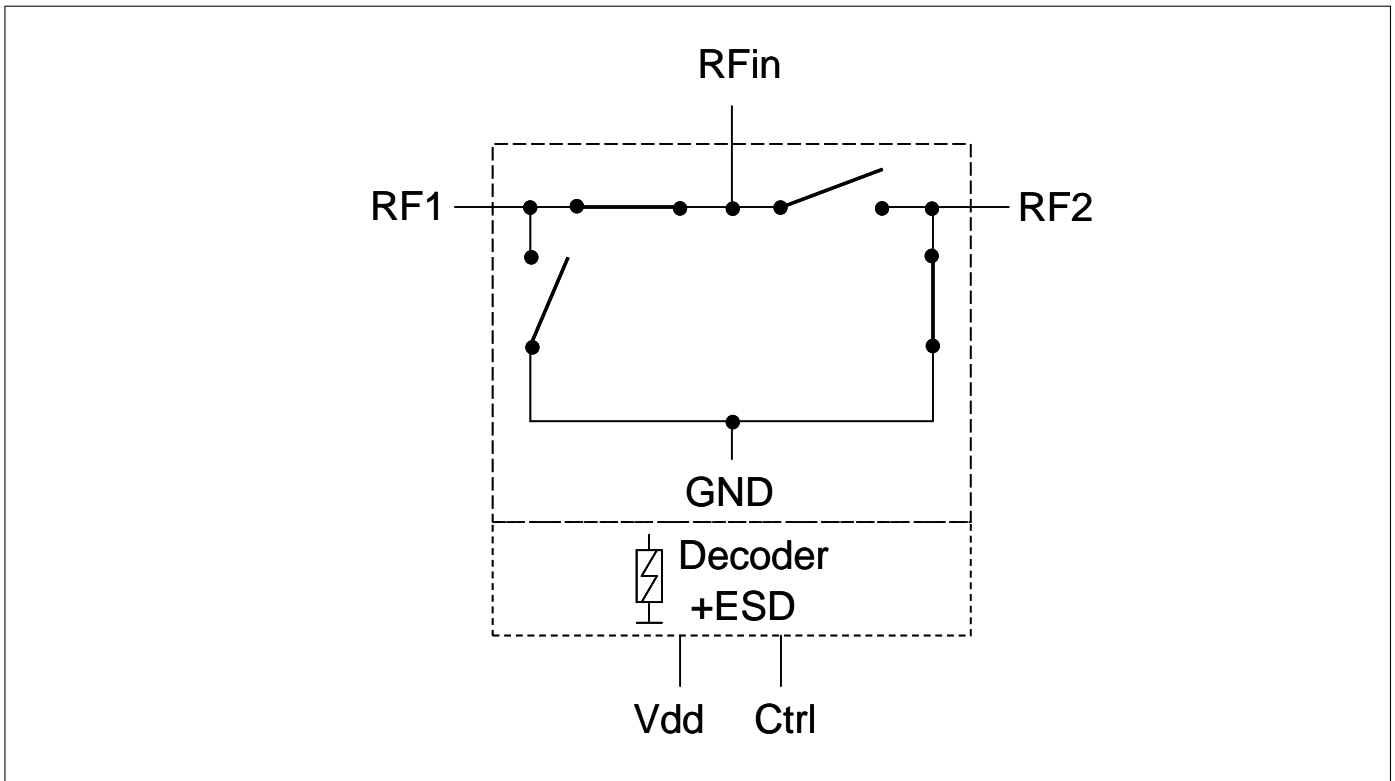

Figure 1: BGS12PL6 Block Diagram

Table 2: Truth Table

Switched Paths	Ctrl
RFin - RF1	0
RFin - RF2	1

### 3 Maximum Ratings

**Table 3: Maximum Ratings** at  $T_A = 25\text{ }^\circ\text{C}$ , unless otherwise specified

Parameter	Symbol	Values			Unit	Note / Test Condition
		Min.	Typ.	Max.		
Supply Voltage	$V_{dd}$	-0.5	–	5.5	V	–
Control Voltage	$V_{Ctrl}$	-0.3	–	3.6	V	–
Storage Temperature Range	$T_{STG}$	-55	–	150	$^\circ\text{C}$	–
RF Input Power at all RF Ports	$P_{RF}$	–	–	36	dBm	CW
Junction Temperature	$T_j$	–	–	125	$^\circ\text{C}$	–
<b>ESD Capability</b>						
Human Body Model <sup>1)</sup>	$V_{ESD\_HBM}$	–1	–	+1	kV	–
ESD Capability RFin Port <sup>2)</sup>	$V_{ESD\_RFin}$	–8	–	+8	kV	RFin versus GND, with 27 nH shunt inductor

<sup>1)</sup> Human Body Model ANSI/ESDA/JEDEC JS-001-2012 ( $R = 1.5\text{ k}\Omega$ ,  $C = 100\text{ pF}$ ).

<sup>2)</sup> IEC 61000-4-2 ( $R = 330\text{ }\Omega$ ,  $C = 150\text{ pF}$ ), contact discharge.

#### Attention:

Stresses above the max. values listed here may cause permanent damage to the device. Exposure to absolute maximum rating conditions for extended periods may affect device reliability. Maximum ratings are absolute ratings; exceeding only one of these values may cause irreversible damage to the integrated circuit.

### 4 Operation Ranges

**Table 4: Operation Ranges**

Parameter	Symbol	Values			Unit	Note / Test Condition
		Min.	Typ.	Max.		
Ambient Temperature	$T_A$	-40	25	85	$^\circ\text{C}$	–
RF Frequency	$f$	0.03	–	4	GHz	–
Supply Voltage	$V_{dd}$	2.4	–	3.6	V	–
Control Voltage Low	$V_{Ctrl\_L}$	-0.3	–	0.3	V	–
Control Voltage High	$V_{Ctrl\_H}$	1.4	–	$V_{dd}$	V	–

**Table 5: RF Input Power**

Parameter	Symbol	Values			Unit	Note / Test Condition
		Min.	Typ.	Max.		
RF Input Power (50 $\Omega$ )	$P_{In}$	–	–	35	dBm	–

## 5 RF Characteristics

**Table 6: RF Characteristics**

Test Conditions (unless otherwise specified):

- Terminating port impedance:  $Z_0 = 50 \Omega$
- Temperature range:  $T_A = -40 \dots +85 \text{ }^\circ\text{C}$
- Supply voltage:  $V_{dd} = 2.4 \dots 3.6 \text{ V}$
- Input power:  $P_{IN} = 0 \text{ dBm}$

Parameter	Symbol	Values			Unit	Note / Test Condition
		Min.	Typ.	Max.		
<b>Insertion Loss</b>						
All RF Ports	$IL$	0.27	0.36	0.55	dB	699-915 MHz
		0.36	0.46	0.70	dB	1710-1910 MHz
		0.46	0.56	0.85	dB	2170-2690 MHz
		0.61	0.77	1.15	dB	3800 MHz
<b>Insertion Loss<sup>1</sup></b>						
All RF Ports	$IL$	0.33	0.36	0.40	dB	699-915 MHz
		0.40	0.46	0.50	dB	1710-1910 MHz
		0.52	0.56	0.65	dB	2170-2690 MHz
		0.65	0.77	0.90	dB	3800 MHz
<b>Return Loss</b>						
All RF Ports	$RL$	20	25	35	dB	699-915 MHz
		16	20	28	dB	1710-1910 MHz
		14	18	27	dB	2170-2690 MHz
		12	15	20	dB	3800 MHz
<b>Isolation</b>						
RFIn to RF1/RF2 Port	$ISO_{RFIn-RFx}$	34	37	–	dB	699-915 MHz
		27	30	–	dB	1710-1910 MHz
		23	27	–	dB	2170-2690 MHz
		19	22	–	dB	3800 MHz
RF1 to RF2 Port	$ISO_{Port-Port}$	45	50	–	dB	699-915 MHz
		34	36	–	dB	1710-1910 MHz
		28	31	–	dB	2170-2690 MHz
		24	27	–	dB	3800 MHz
<b>P0.1 dB Compression Point</b>						
All RF Ports	$P_{0.1dB}$	–	38	–	dBm	699 - 2700 MHz

<sup>1</sup>  $T_A = +25 \text{ }^\circ\text{C}$ ,  $V_{dd} = 3 \text{ V}$

Parameter	Symbol	Values			Unit	Note / Test Condition
		Min.	Typ.	Max.		
<b>Harmonic Generation up to 12.75 GHz<sup>1</sup></b>						
All RF Ports, 2 <sup>nd</sup> Harmonic	$P_{Harm}$	-90	-80	-70	dBc	$f = 824\text{ MHz}$ , $P_{in} = 27.5\text{ dBm}$ , 50Ω, 50 % duty cycle
All RF Ports, 3 <sup>rd</sup> Harmonic		-100	-90	-80	dBc	
<b>Intermodulation Distortion in Rx Band<sup>1,2</sup></b>						
IMD2, Low	$IMD2_{Low}$	–	-110	-100	dBm	Tx = 15 dBm, Interferer = -15 dBm, 50Ω
IMD3	$IMD3$	–	-110	-100	dBm	
IMD2, High	$IMD2_{High}$	–	-110	-100	dBm	
<b>Switching Time and Current Consumption</b>						
RF Rise Time	$t_{10\%-90\%}$	–	0.55	1.5	μs	10% - 90% of RF Signal
Ctrl to RF Time	$t_{Ctrl-RF}$	–	1.4	3	μs	50% of Ctrl Signal to 90% of RF Signal
Supply Current	$I_{dd}$	80	200	350	μA	–
Control Current	$I_{Ctrl}$	–	1	10	μA	–

Note: All electrical characteristics are measured with all RF ports terminated by 50 Ω loads.

<sup>1</sup>  $T_A = +25^\circ\text{C}$ ,  $V_{dd} = 3\text{ V}$

<sup>2</sup> With external shunt L

## 6 Pin Description

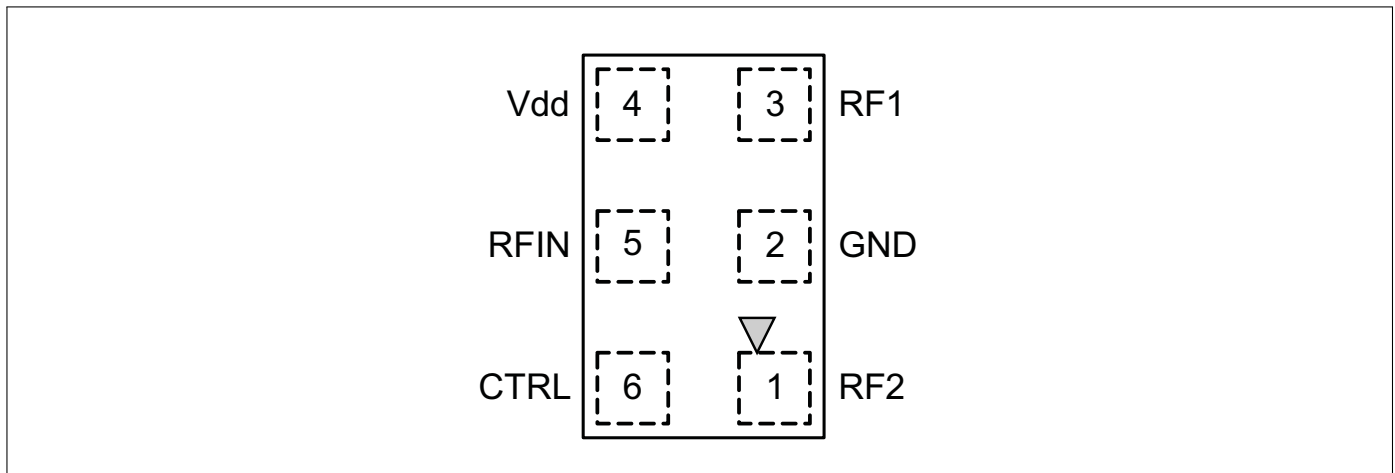

Figure 2: Pin Configuration

Table 7: Pin Description

Pin No.	Name	Pin Type	Buffer Type	Function
1	RF2	I/O		RF Port 2
2	GND	GND		Ground
3	RF1	I/O		RF Port 1
4	Vdd	PWR		Supply Voltage
5	RFIN	I/O		RF Port In
6	CTRL	I		Control Pin

## 7 Package Information

Table 8: Mechanical Data

Parameter	Symbol	Value	Unit
X-Dimension	<i>X</i>	0.7 ± 0.05	mm
Y-Dimension	<i>Y</i>	1.1 ± 0.05	mm
Size	<i>Size</i>	0.77	mm <sup>2</sup>
Height	<i>H</i>	0.31+0.01/-0.02	mm

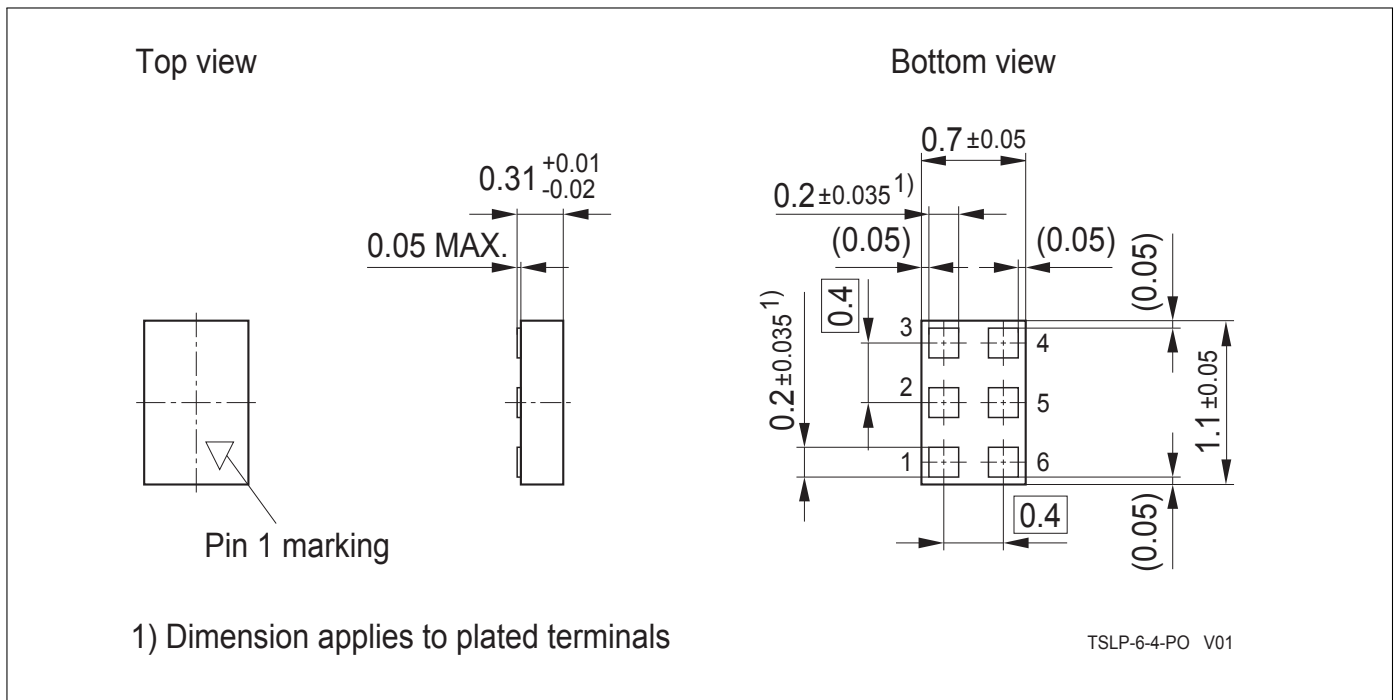

Figure 3: Package Outline

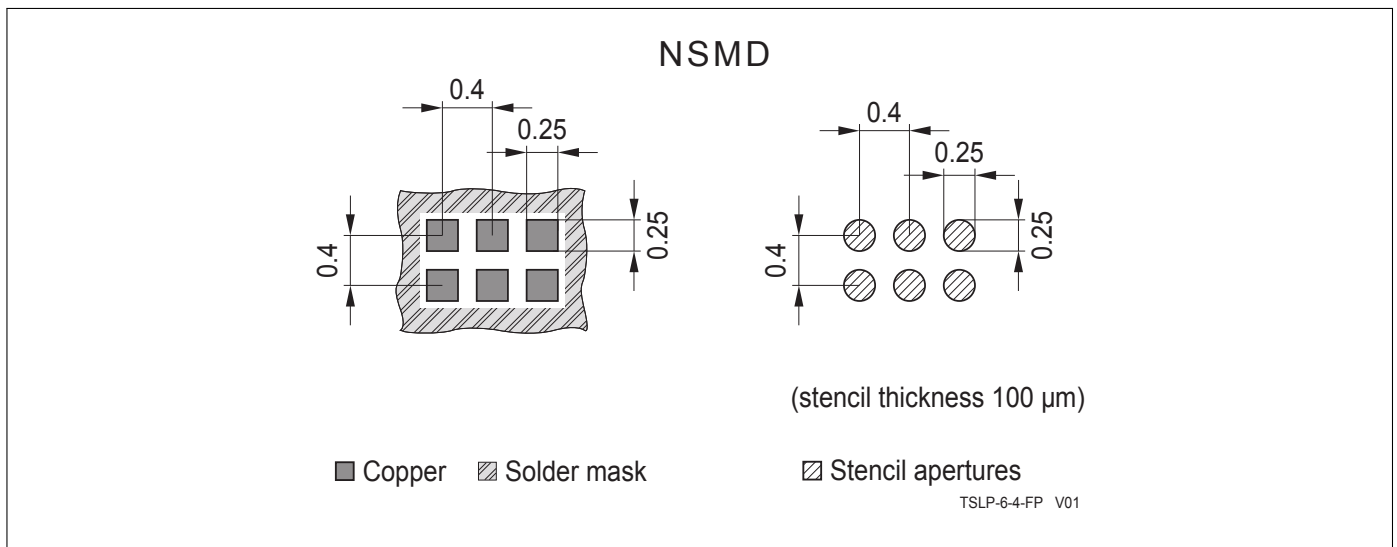

Figure 4: Footprint

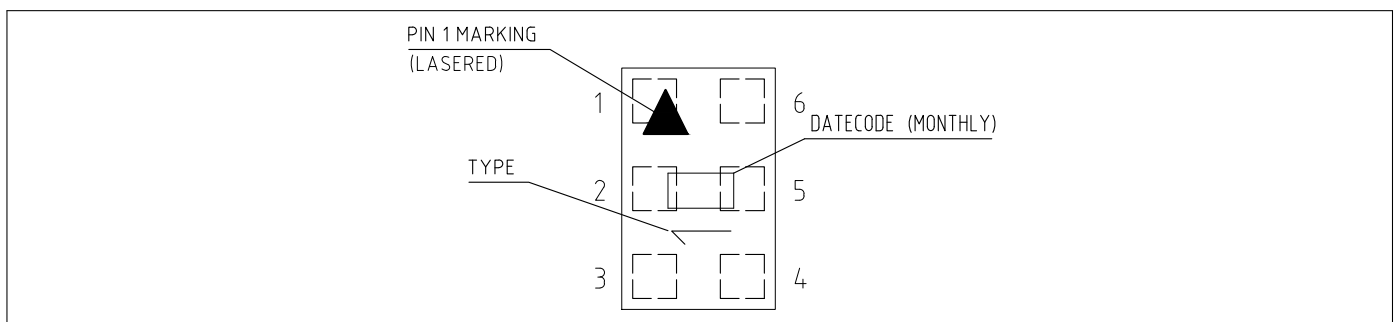

Figure 5: Pin 1 Marking (top view)

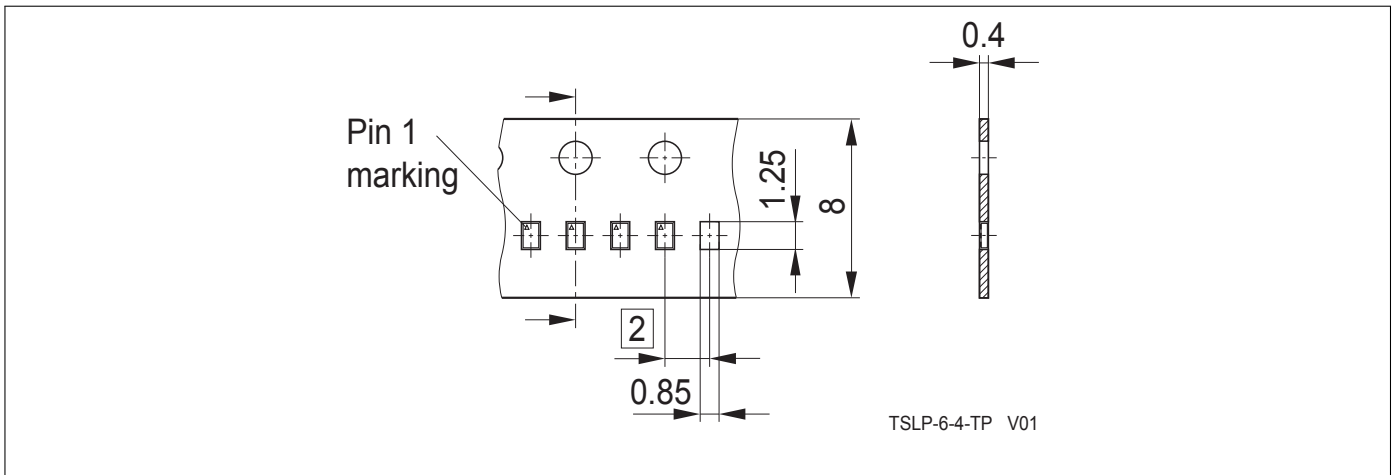



Figure 6: Tape Drawing for TSLP-6-4

[www.infineon.com](http://www.infineon.com)

Published by Infineon Technologies AG

## Looking for pricing, stock, or lifecycle information?

Click below to explore more details on WIN SOURCE:

-  [View BGS12PL6E6327XTSA1 on WIN SOURCE](#)
-  [Infineon Technologies Information](#)

## Optimize Your Supply Chain with WIN SOURCE Solutions

-  Global Sourcing Solution
-  Obsolete Management
-  Cost Control Management
-  Shortage Management
-  Alternative Solution
-  Excess Inventory Management