

# DATA SHEET

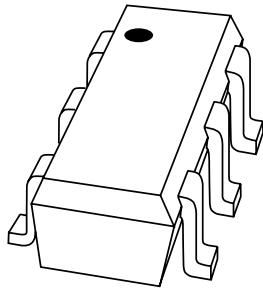

## **BGM1011** MMIC wideband amplifier

Preliminary specification

2002 Jan 14

# MMIC wideband amplifier

# BGM1011

## FEATURES

- Internally matched to 50 Ω
- Very high gain (up to 37 dB at 2 GHz)
- Sloped gain curve for optimal performance with output into lossy cable
- 14 dBm saturated output power at 1 GHz
- High linearity (23 dBm IP3<sub>(out)</sub> at 1 GHz)
- 40 dB isolation

## APPLICATIONS

- LNB IF amplifiers
- Cable systems
- General purpose.

## DESCRIPTION

Silicon Monolithic Microwave Integrated Circuit (MMIC) wideband amplifier with internal matching circuit in a 6-pin SOT363 SMD plastic package.

## PINNING

PIN	DESCRIPTION
1	V <sub>S</sub>
2, 5	GND2
3	RF out
4	GND1
6	RF in

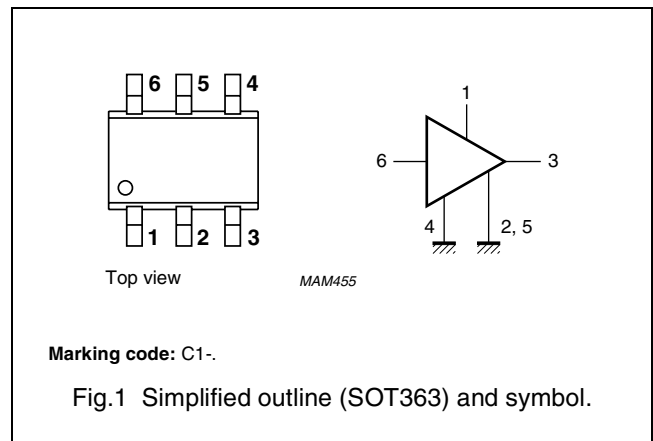

## QUICK REFERENCE DATA

SYMBOL	PARAMETER	CONDITIONS	TYP.	MAX.	UNIT
V <sub>S</sub>	DC supply voltage		5	6	V
I <sub>S</sub>	DC supply current		25.5	–	mA
S <sub>21</sub>   <sup>2</sup>	insertion power gain	f = 1 GHz	30	–	dB
NF	noise figure	f = 1 GHz	4.7	–	dB
P <sub>L(sat)</sub>	saturated load power	f = 1 GHz	13.8	–	dBm

## LIMITING VALUES

In accordance with the Absolute Maximum Rating System (IEC 60134)

SYMBOL	PARAMETER	CONDITIONS	MIN.	MAX.	UNIT
V <sub>S</sub>	DC supply voltage	RF input AC coupled	–	6	V
I <sub>S</sub>	supply current		–	35	mA
P <sub>tot</sub>	total power dissipation	T <sub>s</sub> ≤ 90 °C	–	200	mW
T <sub>stg</sub>	storage temperature		–65	+150	°C
T <sub>j</sub>	operating junction temperature		–	150	°C
P <sub>D</sub>	maximum drive power		–	0	dBm

## CAUTION

This product is supplied in anti-static packing to prevent damage caused by electrostatic discharge during transport and handling. For further information, refer to Philips specs.: SNW-EQ-608, SNW-FQ-302A and SNW-FQ-302B.

## MMIC wideband amplifier

## BGM1011

## THERMAL RESISTANCE

SYMBOL	PARAMETER	CONDITIONS	VALUE	UNIT
$R_{th\ j-s}$	thermal resistance from junction to solder point	$P_{tot} = 200\text{ mW}; T_s \leq 90\text{ }^\circ\text{C}$	300	K/W

## CHARACTERISTICS

$V_S = 5\text{ V}; I_S = 25.5\text{ mA}; T_j = 25\text{ }^\circ\text{C}$  unless otherwise specified.

SYMBOL	PARAMETER	CONDITIONS	MIN.	TYP.	MAX.	UNIT
$I_S$	supply current		20	25.5	32	mA
$ S_{21} ^2$	insertion power gain	$f = 100\text{ MHz}$	–	25	–	dB
		$f = 1\text{ GHz}$	–	30	–	dB
		$f = 1.8\text{ GHz}$	–	35	–	dB
		$f = 2.2\text{ GHz}$	–	37	–	dB
		$f = 2.6\text{ GHz}$	–	32	–	dB
		$f = 3\text{ GHz}$	–	28	–	dB
$R_{L\ IN}$	return losses input	$f = 1\text{ GHz}$	–	11	–	dB
		$f = 2.2\text{ GHz}$	–	8	–	dB
$R_{L\ OUT}$	return losses output	$f = 1\text{ GHz}$	–	18	–	dB
		$f = 2.2\text{ GHz}$	–	12	–	dB
NF	noise figure	$f = 1\text{ GHz}$	–	4.7	–	dB
		$f = 2.2\text{ GHz}$	–	4.6	–	dB
BW	bandwidth	at $ S_{21} ^2 -3\text{ dB}$ below flat gain at 1 GHz	–	2.9	–	GHz
K	stability factor	$f = 1\text{ GHz}$	–	1.8	–	–
		$f = 2.2\text{ GHz}$	–	0.9	–	–
$P_{L(sat)}$	saturated load power	$f = 1\text{ GHz}$	–	13.8	–	dBm
		$f = 2.2\text{ GHz}$	–	10.8	–	dBm
$P_{L\ 1\text{ dB}}$	load power	at 1 dB gain compression; $f = 1\text{ GHz}$	–	12.2	–	dBm
		at 1 dB gain compression; $f = 2.2\text{ GHz}$	–	7.7	–	dBm
$IP3_{(in)}$	input intercept point	$f = 1\text{ GHz}$	–	–7	–	dBm
		$f = 2.2\text{ GHz}$	–	–20	–	dBm
$IP3_{(out)}$	output intercept point	$f = 1\text{ GHz}$	–	23	–	dBm
		$f = 2.2\text{ GHz}$	–	16	–	dBm

MMIC wideband amplifier

BGM1011

APPLICATION INFORMATION

Figure 2 shows a typical application circuit for the BGM1011 MMIC. The device is internally matched to 50 Ω, and therefore does not need any external matching. The value of the input and output DC blocking capacitors C1, C2 should be not more than 100 pF for applications above 100 MHz. Their values can be used to fine tune the input and output impedance. However, when the device is operated below 100 MHz, the capacitor value should be increased.

The nominal value of the RF choke, L1 is 100 nH. At frequencies below 100 MHz this value should be increased to 200 nH. At frequencies between 1 and 3 GHz a much lower value must be used (e.g. 18 nH) to improve return losses. For optimal results, a good quality chip inductor such as the TDK MLG 1608 (0603), or a wire-wound SMD type should be chosen.

Capacitor, C4 and resistor, R1 are added for optimal supply decoupling.

Both the RF choke, L1 and the 22 nF supply decoupling capacitor, C3 should be located as closely as possible to the MMIC.

Separate paths must be used for the ground planes of the ground pins GND1, GND2, and these paths must be as short as possible. When using vias, use multiple vias per pin in order to limit ground path inductance.

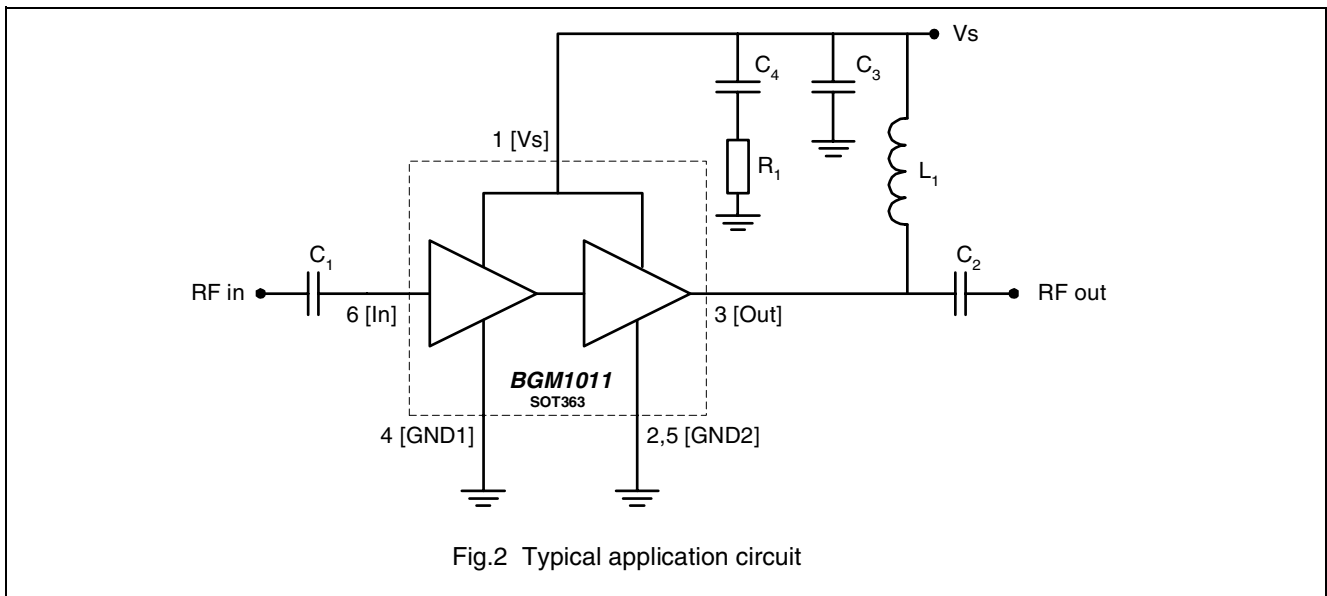

List of components used for the typical application; an amplifier for LNB IF output.

COMPONENT	DESCRIPTION	VALUE	DIMENSIONS.
C1, C2	multilayer ceramic chip capacitor	100 pF	0603
C3	multilayer ceramic chip capacitor	22 nF	0603
C4	multilayer ceramic chip capacitor	5.6 pF	0603
R1	SMD resistor	10 Ω	0603
L1	SMD inductor	10 to 200 nH	0603

MMIC wideband amplifier

BGM1011

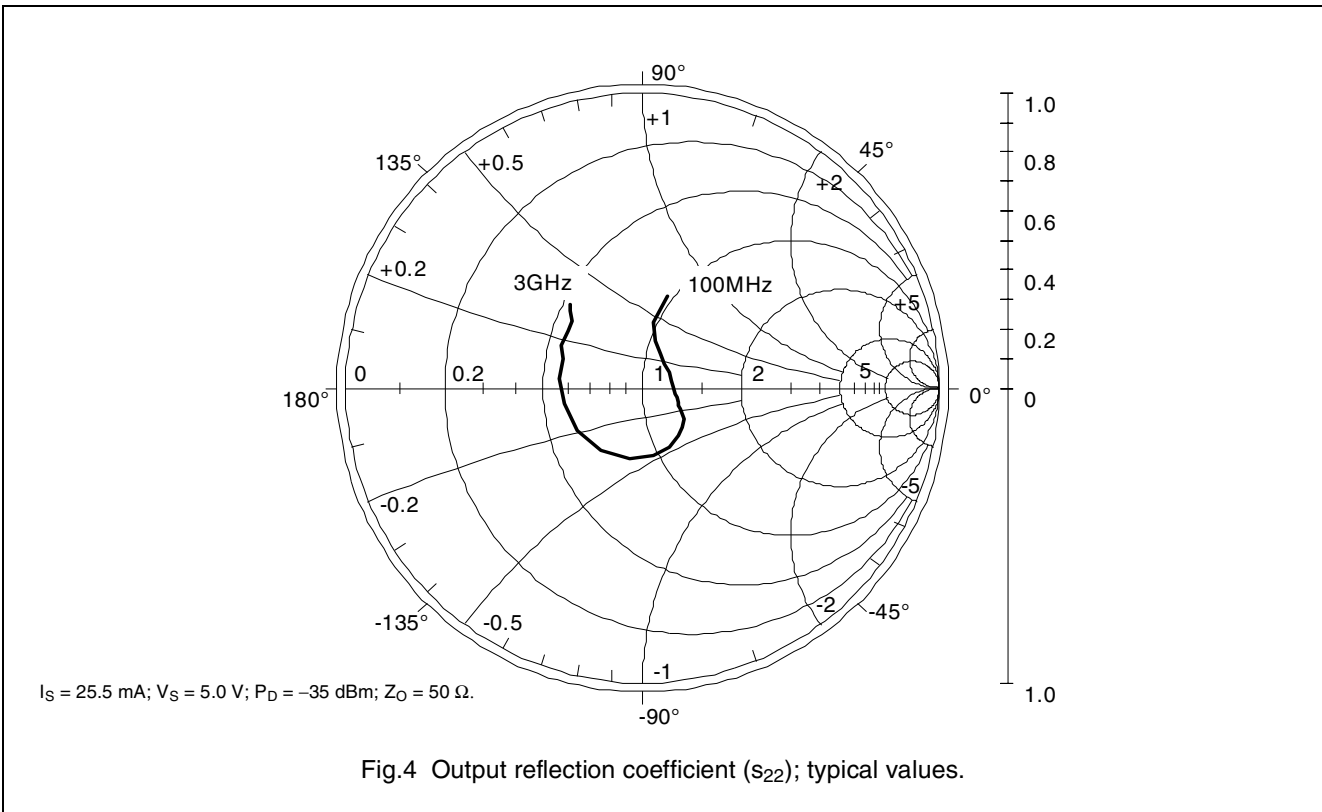
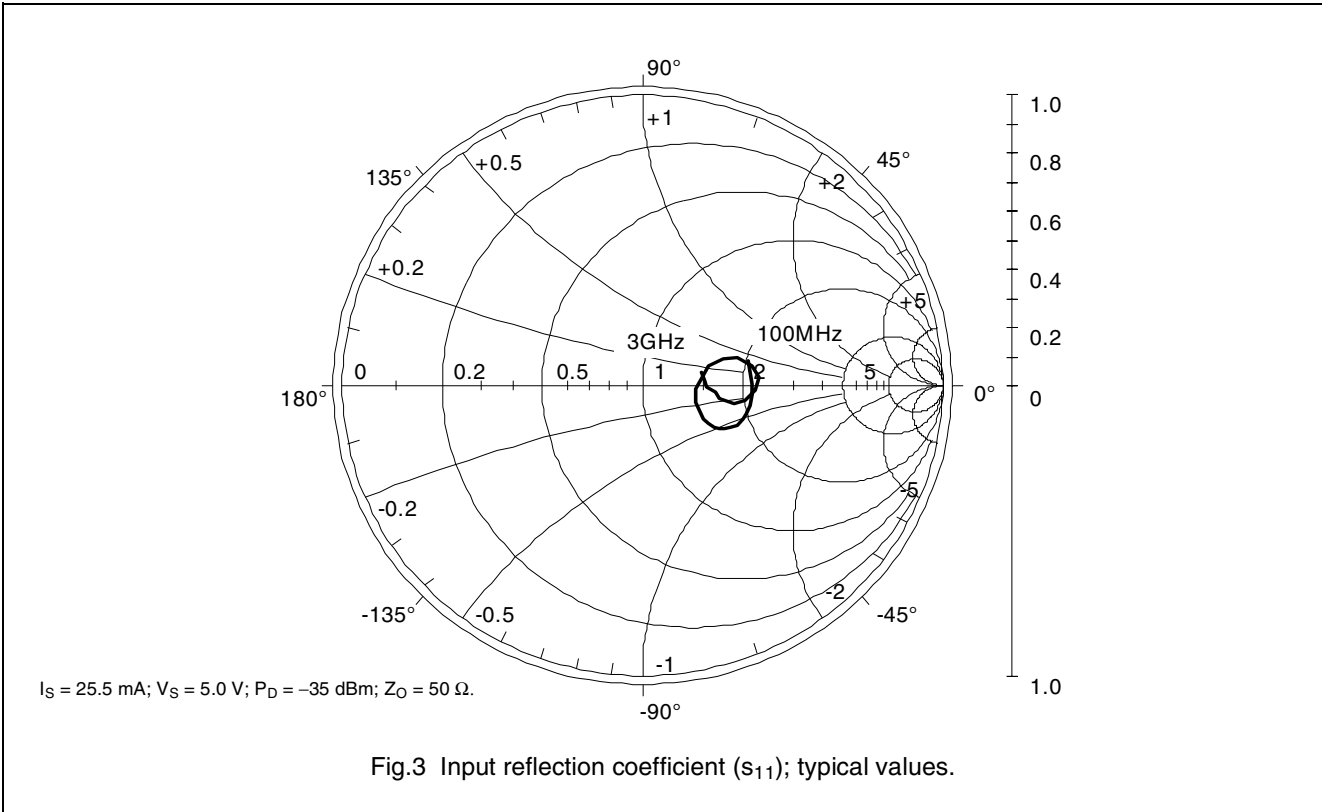

MMIC wideband amplifier

BGM1011

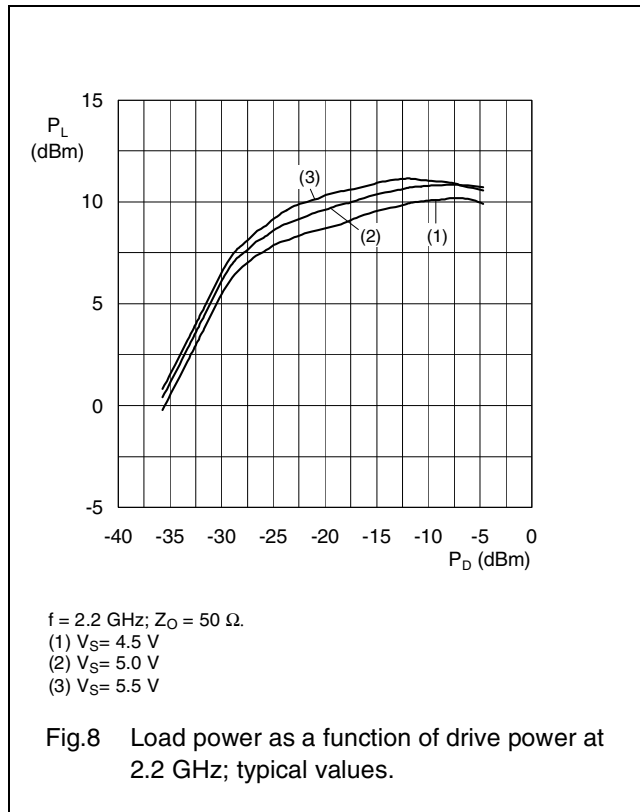
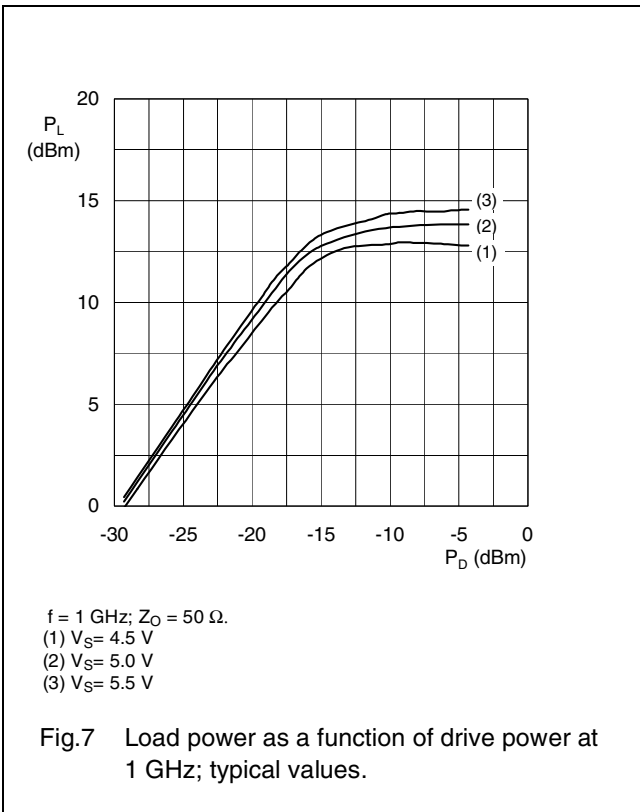
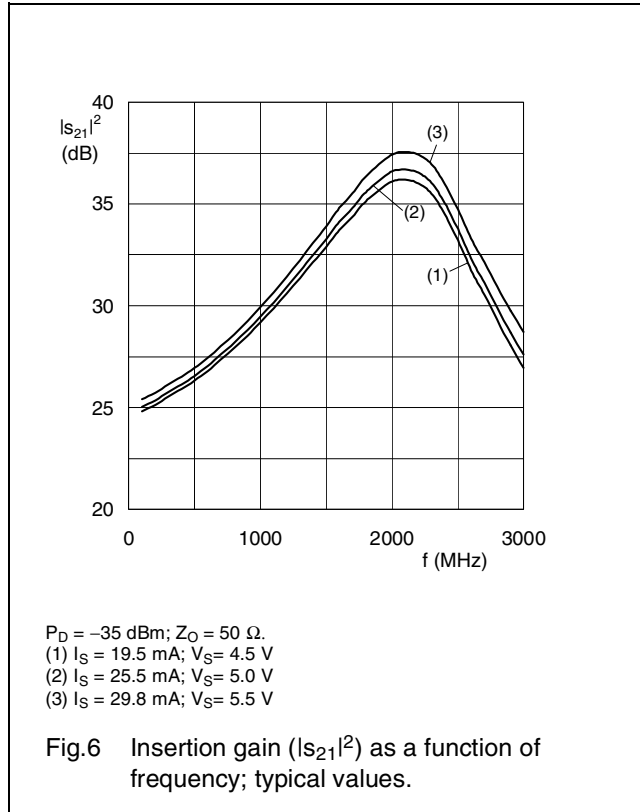
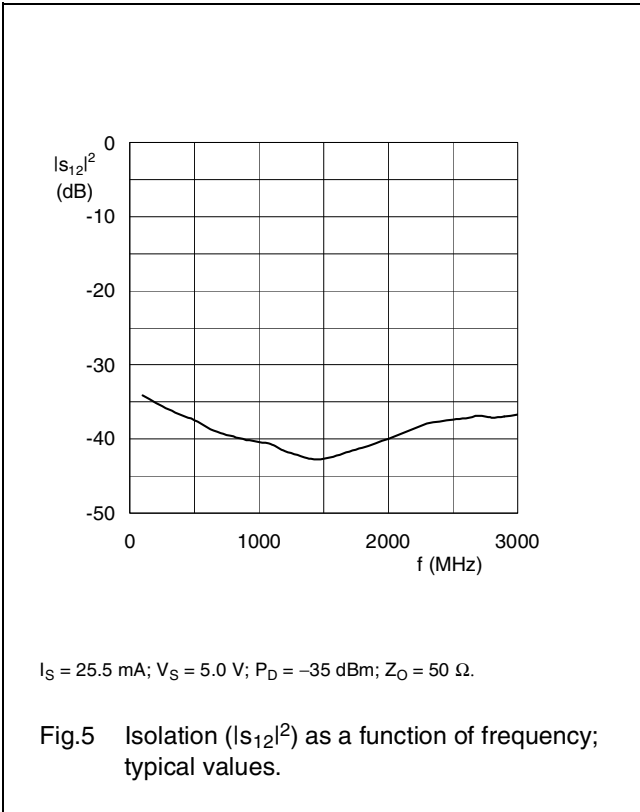

MMIC wideband amplifier

BGM1011

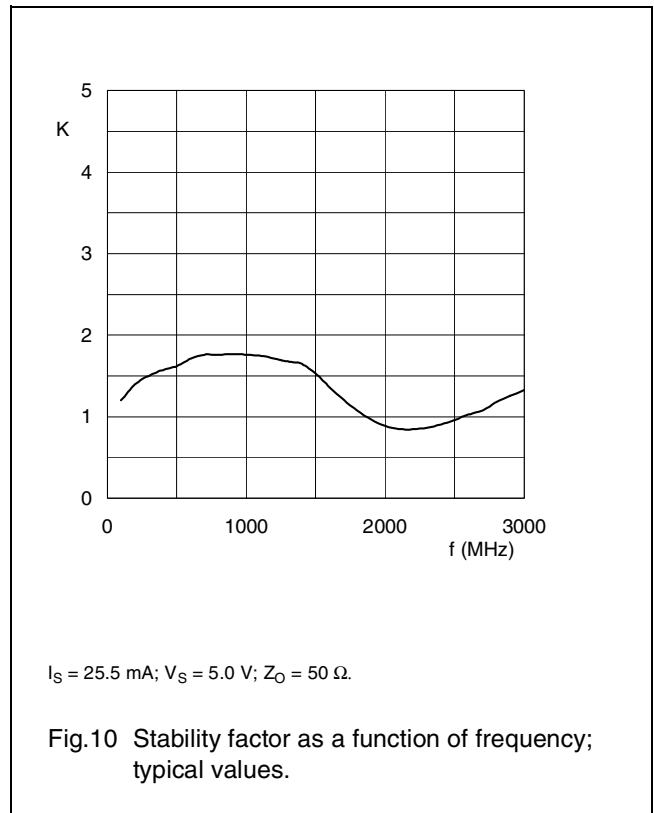
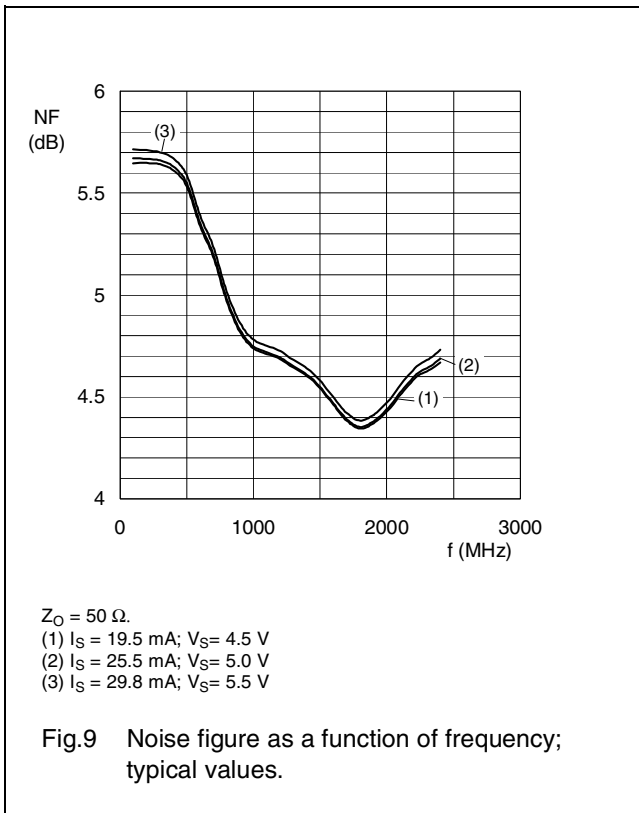

MMIC wideband amplifier

BGM1011

Scattering parameters:  $V_S = 5.0\text{ V}$ ;  $I_S = 25.5\text{ mA}$ ;  $P_D = -35\text{ dBm}$ ;  $Z_O = 50\ \Omega$ ;  $T_{amb} = 25\text{ }^\circ\text{C}$

f (MHz)	S <sub>11</sub>		S <sub>21</sub>		S <sub>12</sub>		S <sub>22</sub>		K-FACTOR
	MAGNITUDE (ratio)	ANGLE(deg)	MAGNITUDE (ratio)	ANGLE (deg)	MAGNITUDE (ratio)	ANGLE (deg)	MAGNITUDE (ratio)	ANGLE (deg)	
100	0.36264	13.342	17.83811	24.366	0.01974	16.631	0.32582	75.129	1.2
200	0.36374	0.954	18.52172	12.011	0.017526	3.391	0.22343	80.749	1.4
400	0.36404	-11.09	20.26048	4.008	0.014492	-9.722	0.13121	63.715	1.6
600	0.35160	-19.36	4.7	-1.373	0.011953	-9.388	0.10301	30.828	1.7
800	0.32818	-26.32	13.8	-7.408	0.010391	-5.884	0.10619	1.087	1.8
1000	0.29729	-29.66	29.73953	-14.9	0.009534	-0.816	0.12032	-15.72	1.7
1200	0.25490	-31.1	35.11364	-24.67	0.008254	9.695	0.13665	-25.66	1.7
1400	0.20591	-24.6	42.13907	-36.83	0.007313	23.979	0.15786	-33.18	1.6
1600	0.18024	-4.547	50.8261	-52.69	0.007684	33.26	0.18642	-44.12	1.4
1800	0.23153	16.758	60.12684	-73.19	0.008713	44.601	0.21778	-65.13	1.1
2000	0.32983	16.643	67.60676	-100.2	0.010019	42.512	0.24156	-100.6	0.9
2200	0.39031	4.096	67.08784	-131.3	0.011761	49.659	0.26347	-146.8	0.9
2400	0.34466	-8.496	56.50393	-160.5	0.013121	46.727	0.28137	173.89	0.9
2600	0.25915	-10.05	41.27266	178.27	0.013803	52.913	0.30823	151.71	1.0
2800	0.21573	-1.301	31.24721	164.33	0.013946	50.499	0.33170	136.52	1.2
3000	0.20270	12.698	23.98115	154.16	0.014548	55.48	0.37422	130.13	1.3

MMIC wideband amplifier

BGM1011

PACKAGE OUTLINE

Plastic surface mounted package; 6 leads

SOT363

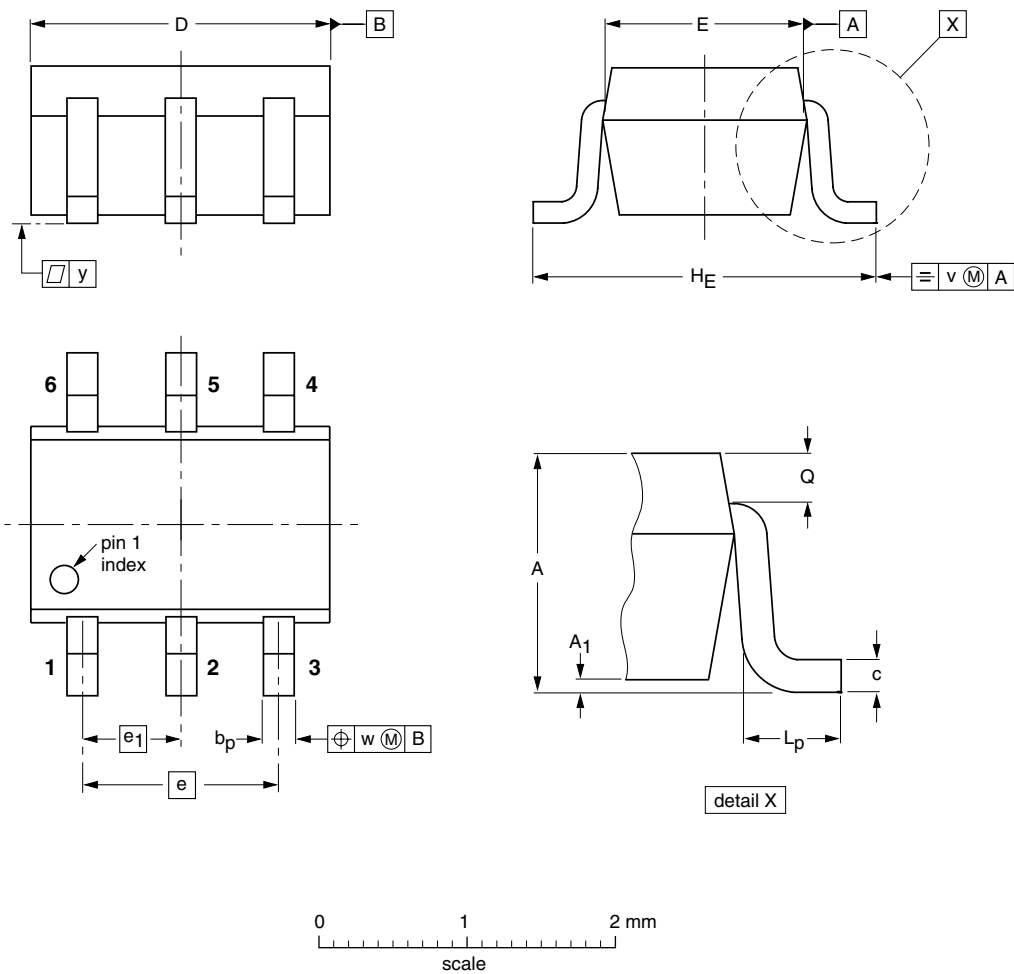

DIMENSIONS (mm are the original dimensions)

UNIT	A	A <sub>1</sub> max	b <sub>p</sub>	c	D	E	e	e <sub>1</sub>	H <sub>E</sub>	L <sub>p</sub>	Q	v	w	y
mm	1.1 0.8	0.1	0.30 0.20	0.25 0.10	2.2 1.8	1.35 1.15	1.3	0.65	2.2 2.0	0.45 0.15	0.25 0.15	0.2	0.2	0.1

OUTLINE VERSION	REFERENCES				EUROPEAN PROJECTION	ISSUE DATE
	IEC	JEDEC	EIAJ			
SOT363			SC-88			97-02-28

## MMIC wideband amplifier

BGM1011

## DATA SHEET STATUS

DATA SHEET STATUS <sup>(1)</sup>	PRODUCT STATUS <sup>(2)</sup>	DEFINITIONS
Objective data	Development	This data sheet contains data from the objective specification for product development. Philips Semiconductors reserves the right to change the specification in any manner without notice.
Preliminary data	Qualification	This data sheet contains data from the preliminary specification. Supplementary data will be published at a later date. Philips Semiconductors reserves the right to change the specification without notice, in order to improve the design and supply the best possible product.
Product data	Production	This data sheet contains data from the product specification. Philips Semiconductors reserves the right to make changes at any time in order to improve the design, manufacturing and supply. Changes will be communicated according to the Customer Product/Process Change Notification (CPCN) procedure SNW-SQ-650A.

## Notes

1. Please consult the most recently issued data sheet before initiating or completing a design.
2. The product status of the device(s) described in this data sheet may have changed since this data sheet was published. The latest information is available on the Internet at URL <http://www.semiconductors.philips.com>.

## DEFINITIONS

**Short-form specification** — The data in a short-form specification is extracted from a full data sheet with the same type number and title. For detailed information see the relevant data sheet or data handbook.

**Limiting values definition** — Limiting values given are in accordance with the Absolute Maximum Rating System (IEC 60134). Stress above one or more of the limiting values may cause permanent damage to the device. These are stress ratings only and operation of the device at these or at any other conditions above those given in the Characteristics sections of the specification is not implied. Exposure to limiting values for extended periods may affect device reliability.

**Application information** — Applications that are described herein for any of these products are for illustrative purposes only. Philips Semiconductors make no representation or warranty that such applications will be suitable for the specified use without further testing or modification.

## DISCLAIMERS

**Life support applications** — These products are not designed for use in life support appliances, devices, or systems where malfunction of these products can reasonably be expected to result in personal injury. Philips Semiconductors customers using or selling these products for use in such applications do so at their own risk and agree to fully indemnify Philips Semiconductors for any damages resulting from such application.

**Right to make changes** — Philips Semiconductors reserves the right to make changes, without notice, in the products, including circuits, standard cells, and/or software, described or contained herein in order to improve design and/or performance. Philips Semiconductors assumes no responsibility or liability for the use of any of these products, conveys no licence or title under any patent, copyright, or mask work right to these products, and makes no representations or warranties that these products are free from patent, copyright, or mask work right infringement, unless otherwise specified.

# ***Philips Semiconductors – a worldwide company***

## **Contact information**

For additional information please visit <http://www.semiconductors.philips.com>. Fax: +31 40 27 24825

For sales offices addresses send e-mail to: [sales.addresses@www.semiconductors.philips.com](mailto:sales.addresses@www.semiconductors.philips.com).

© Koninklijke Philips Electronics N.V. 2001

SCA73

All rights are reserved. Reproduction in whole or in part is prohibited without the prior written consent of the copyright owner.

The information presented in this document does not form part of any quotation or contract, is believed to be accurate and reliable and may be changed without notice. No liability will be accepted by the publisher for any consequence of its use. Publication thereof does not convey nor imply any license under patent- or other industrial or intellectual property rights.

Printed in The Netherlands

613516/02/pp11

Date of release: 2002 Jan 14

Document order number: 9397 750 09297

*Let's make things better.*

**Philips  
Semiconductors**



**PHILIPS**

## Looking for pricing, stock, or lifecycle information?

Click below to explore more details on WIN SOURCE:

- [View BGM1011 on WIN SOURCE](#)
- [NXP / Nexperia Information](#)

## Optimize Your Supply Chain with WIN SOURCE Solutions

- ✓ Global Sourcing Solution
- ✓ Obsolete Management
- ✓ Cost Control Management
- ✓ Shortage Management
- ✓ Alternative Solution
- ✓ Excess Inventory Management