



**THE DATASHEET OF
ZL30122GGG**



Features

- Synchronizes with standard telecom system references and synthesizes a wide variety of protected telecom line interface clocks that are compliant with Telcordia GR-253-CORE and ITU-T G.813
- Internal APLL provides standard output clock frequencies up to 622.08 MHz with jitter < 3 ps RMS suitable for GR-253-CORE OC-12 and G.813 STM-16 interfaces
- Programmable output synthesizer generates clock frequencies from any multiple of 8 kHz up to 77.76 MHz in addition to 2 kHz
- Digital Phase Locked-Loop (DPLL) provides all the features necessary for generating SONET/SDH compliant clocks including automatic hitless reference switching, automatic mode selection (locked, free-run, holdover), and selectable loop bandwidth
- Provides 3 reference inputs which support clock frequencies with any multiples of 8 kHz up to 77.76 MHz in addition to 2 kHz

Ordering Information

| | | |
|-------------|---------------|-------|
| ZL30122GGG | 64 Pin CABGA | Trays |
| ZL30122GGG2 | 64 Pin CABGA* | Trays |

*Pb Free Tin/Silver/Copper

-40°C to +85°C

- Provides 3 sync inputs for output frame pulse alignment
- Generates several styles of output frame pulses with selectable pulse width, polarity, and frequency
- Configurable input to output delay, and output to output phase alignment
- Flexible input reference monitoring automatically disqualifies references based on frequency and phase irregularities
- Supports IEEE 1149.1 JTAG Boundary Scan

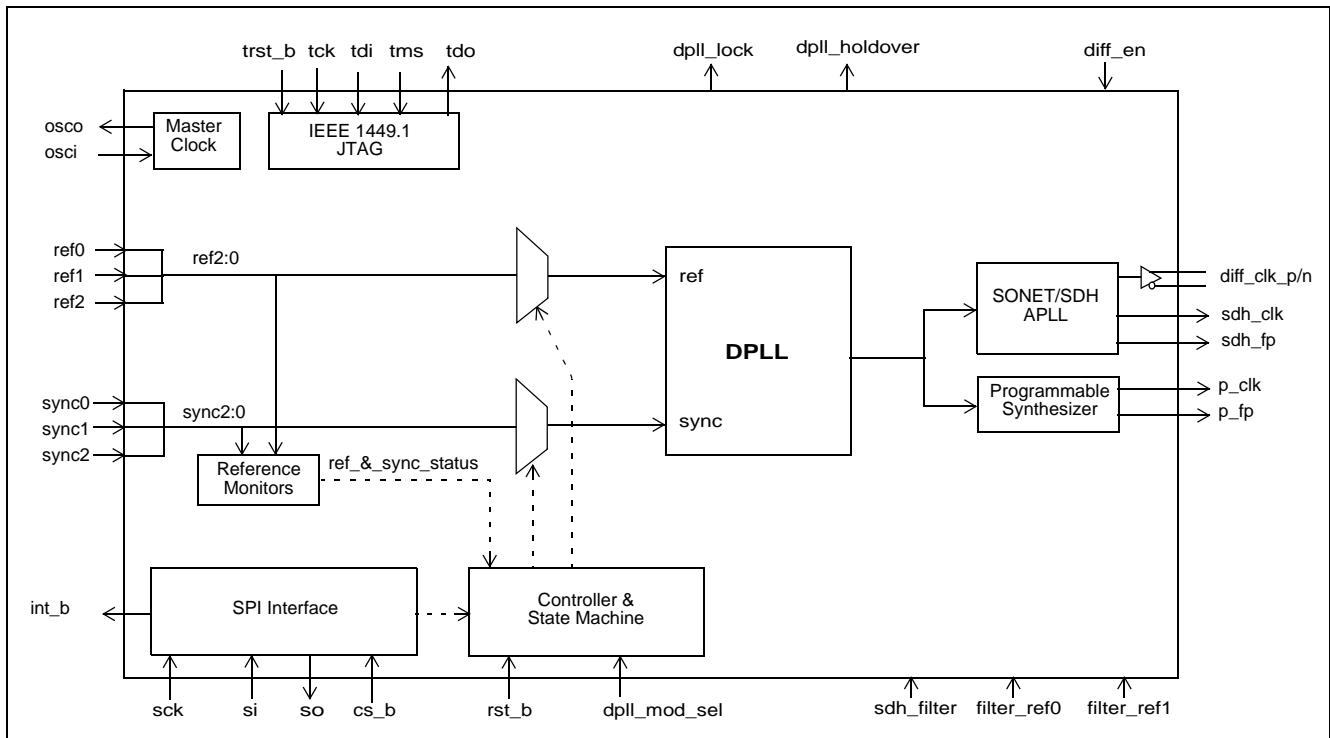

Figure 1 - Block Diagram

Applications

- AMCs for AdvancedTCA™ and MicroTCA Systems
- Multi-Service Edge Switches or Routers
- DSLAM Line Cards
- WAN Line Cards
- RNC/Mobile Switching Center Line Cards
- ADM Line Cards

Table of Contents

| | |
|--|-----------|
| 1.0 Functional Description | 9 |
| 1.1 DPLL Features | 9 |
| 1.2 DPLL Mode Of Operation | 10 |
| 1.3 Ref and Sync Inputs | 11 |
| 1.4 Ref and Sync Monitoring | 12 |
| 1.5 Output Clocks and Frame Pulses | 14 |
| 1.6 Configurable Input-to-Output and Output-to-Output Delays | 15 |
| 2.0 Software Configuration | 16 |
| 3.0 References | 21 |

List of Figures

| | |
|---|----|
| Figure 1 - Block Diagram | 1 |
| Figure 2 - Automatic Mode State Machine | 10 |
| Figure 3 - Reference and Sync Inputs | 11 |
| Figure 4 - Output Frame Pulse Alignment | 11 |
| Figure 5 - Behaviour of the Guard Soak Timer during CFM or SCM Failures | 13 |
| Figure 6 - Output Configuration | 14 |
| Figure 7 - Phase Delay Adjustments | 15 |

List of Tables

Table 1 - DPLL Features 9
Table 2 - Set of Pre-Defined Auto-Detect Clock Frequencies 12
Table 3 - Set of Pre-Defined Auto-Detect Sync Frequencies 12
Table 4 - Output Clock and Frame Pulse Frequencies 14
Table 5 - Register Map 16

Pin Description

| Pin # | Name | I/O Type | Description |
|---------------------------------------|--------------------------|----------------|--|
| Input Reference | | | |
| B1 A3 B4 | ref0 ref1 ref2 | I _d | Input References (LVCMOS, Schmitt Trigger). These are input references available for synchronizing output clocks. All three input references can be automatically or manually selected using software registers. These pins are internally pulled down to V _{ss} . |
| A1 A2 A4 | sync0 sync1 sync2 | I _d | Frame Pulse Synchronization References (LVCMOS, Schmitt Trigger). These are the frame pulse synchronization inputs associated with input references 0, 1 and 2. These inputs accept frame pulses in a clock format (50% duty cycle) or a basic frame pulse format with minimum pulse width of 5 ns. These pins are internally pulled down to V _{ss} . |
| Output Clocks and Frame Pulses | | | |
| D8 | sdh_clk | O | SONET/SDH Output Clock (LVCMOS). This output can be configured to provide any one of the SONET/SDH clock outputs up to 77.76 MHz. The default frequency for this output is 77.76 MHz. |
| D7 | sdh_fp | O | SONET/SDH Output Frame Pulse (LVCMOS). This output can be configured to provide virtually any style of output frame pulse synchronized with an associated SONET/SDH family output clock. The default frequency for this frame pulse output is 8 kHz. |
| G8 | p_clk | O | Programmable Output Clock (LVCMOS). This output can be configured to provide any frequency with a multiple of 8 kHz up to 77.76 MHz in addition to 2 kHz. The default frequency for this output is 2.048 MHz. |
| G7 | p_fp | O | Programmable Output Frame Pulse (LVCMOS). This output can be configured to provide virtually any style of output frame pulse associated with p_clk. The default frequency for this frame pulse output is 8 kHz. |
| A7 B8 | diff_clk_p diff_clk_n | O | Differential Output Clock (LVPECL). This output can be configured to provide any one of the available SDH clock frequencies. The default frequency for this clock output is 622.08 MHz. |
| Control | | | |
| G5 | rst_b | I | Reset (LVCMOS, Schmitt Trigger). A logic low at this input resets the device. To ensure proper operation, the device must be reset after power-up. Reset should be asserted for a minimum of 300 ns. |
| B2 | dppl_mod_sel | I _u | DPLL Mode Select (LVCMOS, Schmitt Trigger). During reset, the level on this pin determines the default mode of operation of the DPLL (Normal or Freerun). After reset, the mode of operation can be controlled directly with these pins, or by accessing the <i>dppl_modesel</i> register through the serial interface. This pin is internally pulled up to V _{dd} . |
| B3 | diff_en | I _u | Differential Output Enable (LVCMOS, Schmitt Trigger). When set high, the differential LVPECL driver is enabled. When set low, the differential driver is tristated reducing power consumption. This function is also controllable through software registers. This pin is internally pulled up to V _{dd} . |

| Pin # | Name | I/O Type | Description |
|-------------------------|---------------|----------------|--|
| Status | | | |
| E1 | dpll_lock | O | Lock Indicator (LVCMOS). This is the lock indicator pin for the DPLL. This output goes high when the DPLL's output is frequency and phase locked to the input reference. |
| H1 | dpll_holdover | O | Holdover Indicator (LVCMOS). This pin goes high when the DPLL enters the holdover mode. |
| Serial Interface | | | |
| C1 | sck | I | Clock for Serial Interface (LVCMOS). Serial interface clock. |
| D2 | si | I | Serial Interface Input (LVCMOS). Serial interface data input pin. |
| D1 | so | O | Serial Interface Output (LVCMOS). Serial interface data output pin. |
| C2 | cs_b | I _u | Chip Select for Serial Interface (LVCMOS). Serial interface chip select. This pin is internally pulled up to V _{dd} . |
| E2 | int_b | O | Interrupt Pin (LVCMOS). Indicates a change of device status prompting the processor to read the enabled interrupt service registers (ISR). This pin is an open drain, active low and requires an external pulled up to V _{DD} . |
| APLL Loop Filter | | | |
| A5 | sdh_filter | A | External Analog PLL Loop Filter terminal. |
| B5 | filter_ref0 | A | Analog PLL External Loop Filter Reference. |
| C5 | filter_ref1 | A | Analog PLL External Loop Filter Reference. |
| JTAG and Test | | | |
| G4 | tdo | O | Test Serial Data Out (Output). JTAG serial data is output on this pin on the falling edge of tck. This pin is held in high impedance state when JTAG scan is not enabled. |
| G2 | tdi | I _u | Test Serial Data In (Input). JTAG serial test instructions and data are shifted in on this pin. This pin is internally pulled up to V _{dd} . If this pin is not used then it should be left unconnected. |
| G3 | trst_b | I _u | Test Reset (LVCMOS). Asynchronously initializes the JTAG TAP controller by putting it in the Test-Logic-Reset state. This pin should be pulsed low on power-up to ensure that the device is in the normal functional state. This pin is internally pulled up to V _{dd} . If this pin is not used then it should be connected to GND. |
| H3 | tck | I | Test Clock (LVCMOS): Provides the clock to the JTAG test logic. If this pin is not used then it should be pulled down to GND. |
| F2 | tms | I _u | Test Mode Select (LVCMOS). JTAG signal that controls the state transitions of the TAP controller. This pin is internally pulled up to V _{DD} . If this pin is not used then it should be left unconnected. |
| Master Clock | | | |
| H4 | osci | I | Oscillator Master Clock Input (LVCMOS). This input accepts a 20 MHz reference from a clock oscillator (XO, XTAL). The stability and accuracy of the clock at this input determines the free-run accuracy and the long term holdover stability of the output clocks. |

| Pin # | Name | I/O Type | Description |
|--|-------------|--|---|
| H5 | osco | O | Oscillator Master Clock Output (LVCMOS). This pin must be left unconnected when the osci pin is connected to a clock oscillator. |
| Miscellaneous | | | |
| F5 | IC | | Internal Connection. Leave unconnected. |
| H6 | IC | | Internal Connection. Connect to ground. |
| H7 | NC | | No Connection. Leave unconnected. |
| H2 | IC | | Internal Connection. Connect to ground. |
| Power and Ground | | | |
| C3 C8 E8 F6 F8 G6 H8 | V_{DD} | P P P P P P P | Positive Supply Voltage. +3.3V _{DC} nominal. |
| E6 F3 | V_{CORE} | P P | Positive Supply Voltage. +1.8V _{DC} nominal. |
| B7 C4 | AV_{DD} | P P | Positive Analog Supply Voltage. +3.3V _{DC} nominal. |
| B6 C7 F1 | AV_{CORE} | P P P | Positive Analog Supply Voltage. +1.8V _{DC} nominal. |
| D3 D4 D5 D6 E3 E4 E5 E7 F4 F7 | V_{SS} | G G G G G G G G G G | Ground. 0 Volts. |
| A6 A8 C6 G1 | AV_{SS} | G G G G | Analog Ground. 0 Volts. |

- I - Input
- I_d - Input, Internally pulled down
- I_u - Input, Internally pulled up
- O - Output
- A - Analog
- P - Power
- G - Ground

1.0 Functional Description

The ZL30122 SONET/SDH Line Card Synchronizer is a highly integrated device that provides timing and synchronization for network interface cards. The DPLL is capable of locking to one of three input references and provides a wide variety of synchronized output clocks and frame pulses.

1.1 DPLL Features

The Digital Phase-Locked Loop synchronizes to one of the qualified references and provides automatic or manual hitless reference switching and a holdover function when no qualified references are available. It provides a highly configurable set of features which are configurable through the serial interface. A summary of these features are shown in Table 1.

| Feature | DPLL |
|--|---|
| Modes of Operation | Free-run, Normal (locked), Holdover |
| Loop Bandwidth | User selectable: 14 Hz, 28 Hz, or wideband ¹ (890 Hz / 56 Hz / 14 Hz) |
| Phase Slope Limiting | User selectable: 885 ns/s, 7.5 μ s/s, 61 μ s/s, or unlimited |
| Pull-in Range | Fixed: 130 ppm |
| Reference Inputs | Ref0, Ref1, Ref2 |
| Sync Inputs | Sync0, Sync1, Sync2 |
| Input Reference Frequencies | 2 kHz, N * 8 kHz up to 77.76 MHz |
| Supported Sync Input Frequencies | 166.67 Hz, 400 Hz, 1 kHz, 2 kHz, 8 kHz, 64 kHz. |
| Input Reference Selection/Switching | Automatic (based on programmable priority and revertiveness), or manual selection |
| Hitless Reference Switching | Can be enabled or disabled |
| Output Clocks | diff_p/n, sdh_clk, p_clk |
| Output Frame Pulses | sdh_fp, p_fp synchronized to active sync reference. |
| Supported Output Clock Frequencies | As listed in Table 4 |
| Supported Output Frame Pulse Frequencies | As listed in Table 4 |
| External Pins Status Indicators | Lock, Holdover |

Table 1 - DPLL Features

1. In the wideband mode, the loop bandwidth depends on the frequency of the reference input. For reference frequencies equal to or greater than 64 kHz, the loop bandwidth = 890 Hz. For reference frequencies equal to or greater than 8 kHz and less than 64 kHz, the loop bandwidth = 56 Hz. For reference frequencies equal to 2 kHz, the loop bandwidth is equal to 14 Hz.

1.2 DPLL Mode Of Operation

The DPLL supports three modes of operation - free-run, normal, and holdover. The mode of operation can be manually set or controlled by an automatic state machine as shown in Figure 2.

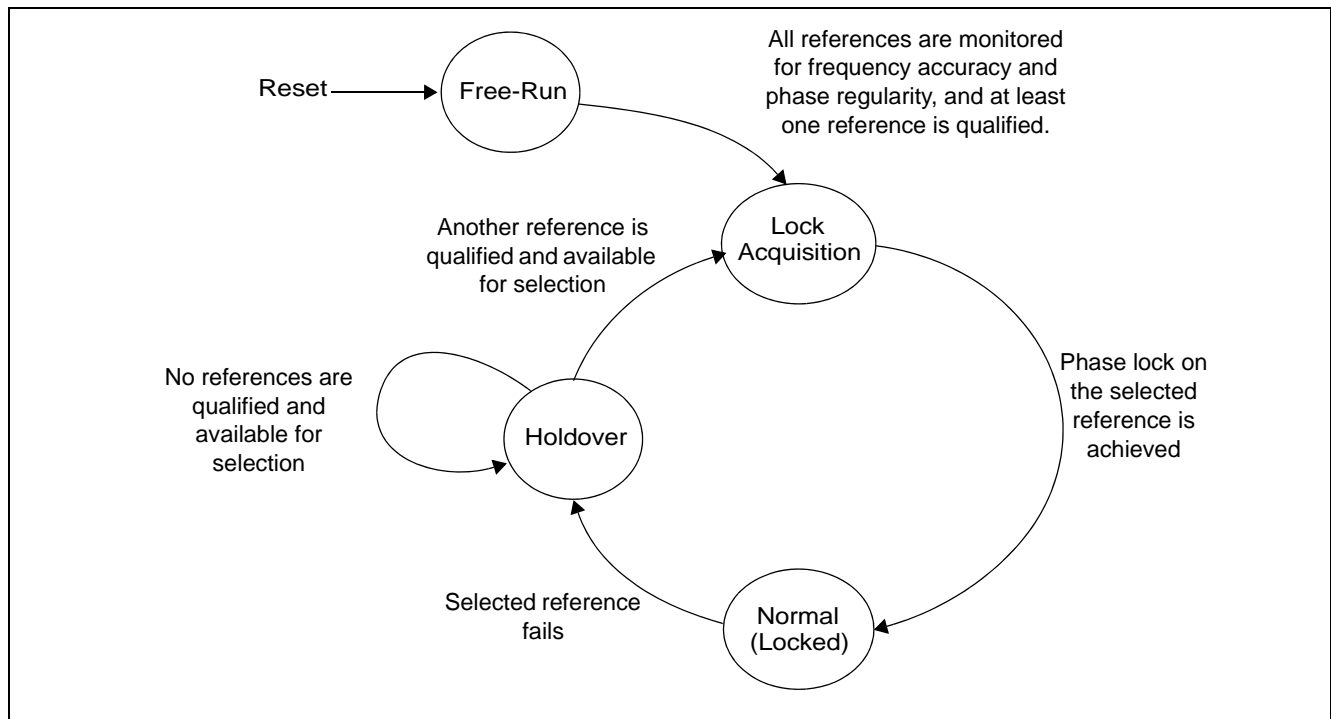

Figure 2 - Automatic Mode State Machine

Free-run

The free-run mode occurs immediately after a reset cycle or when the DPLL has never been synchronized to a reference input. In this mode, the frequency accuracy of the output clocks is equal to the frequency accuracy of the external master oscillator.

Lock Acquisition

The input references are continuously monitored for frequency accuracy and phase regularity. If at least one of the input references is qualified by the reference monitors, then the DPLL will begin lock acquisition on that input. Given a stable reference input, the ZL30122 will enter in the Normal (locked) mode.

Normal (locked)

The usual mode of operation for the DPLL is the normal mode where the DPLL phase locks to a selected qualified reference input and generates output clocks and frame pulses with a frequency accuracy equal to the frequency accuracy of the reference input. While in the normal mode, the DPLL's clock and frame pulse outputs comply with the MTIE and TDEV wander generation specifications as described in Telcordia and ITU-T telecommunication standards.

Holdover

When the DPLL operating in the normal mode loses its reference input, and no other qualified references are available, it will enter the holdover mode and continue to generate output clocks based on historical frequency data collected while the DPLL was synchronized. The transition between normal and holdover modes is controlled by the DPLL so that its initial frequency offset is better than 100 ppb. The frequency drift after this transition period is dependant on the frequency drift of the external master oscillator.

1.3 Ref and Sync Inputs

There are three reference clock inputs (**ref0** to **ref2**) available to the DPLL. Reference selection can be controlled using a built-in state machine or set in a manual mode. The selected reference input is used to synchronize the output clocks.

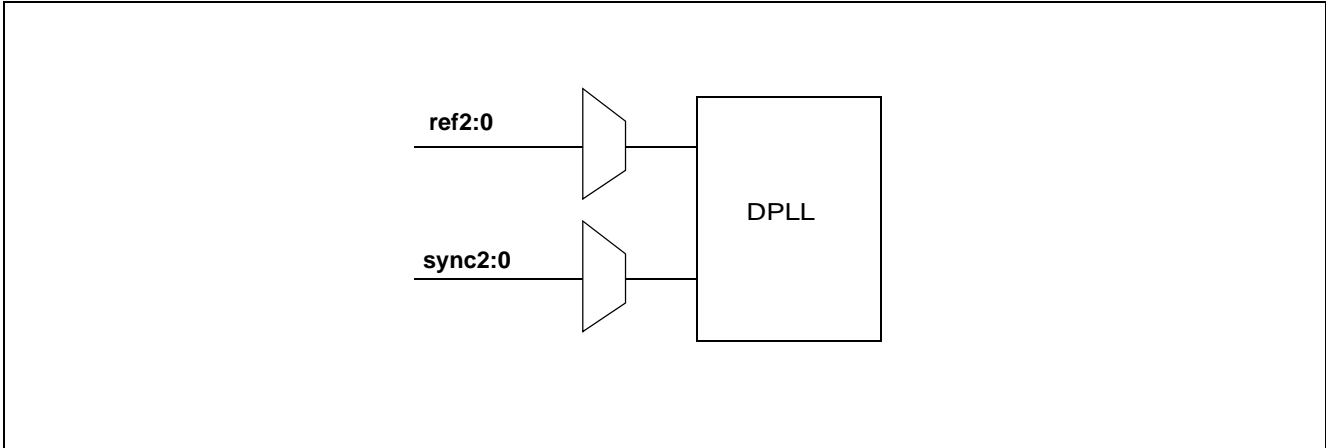

Figure 3 - Reference and Sync Inputs

In addition to the reference inputs, the DPLL has three optional frame pulse synchronization inputs (**sync0** to **sync2**) used to align the output frame pulses. The $sync_n$ input is selected with its corresponding ref_n input, where $n = 0, 1, \text{ or } 2$. Note that the sync input cannot be used to synchronize the DPLL, it only determines the alignment of the frame pulse outputs. An example of output frame pulse alignment is shown in Figure 4.

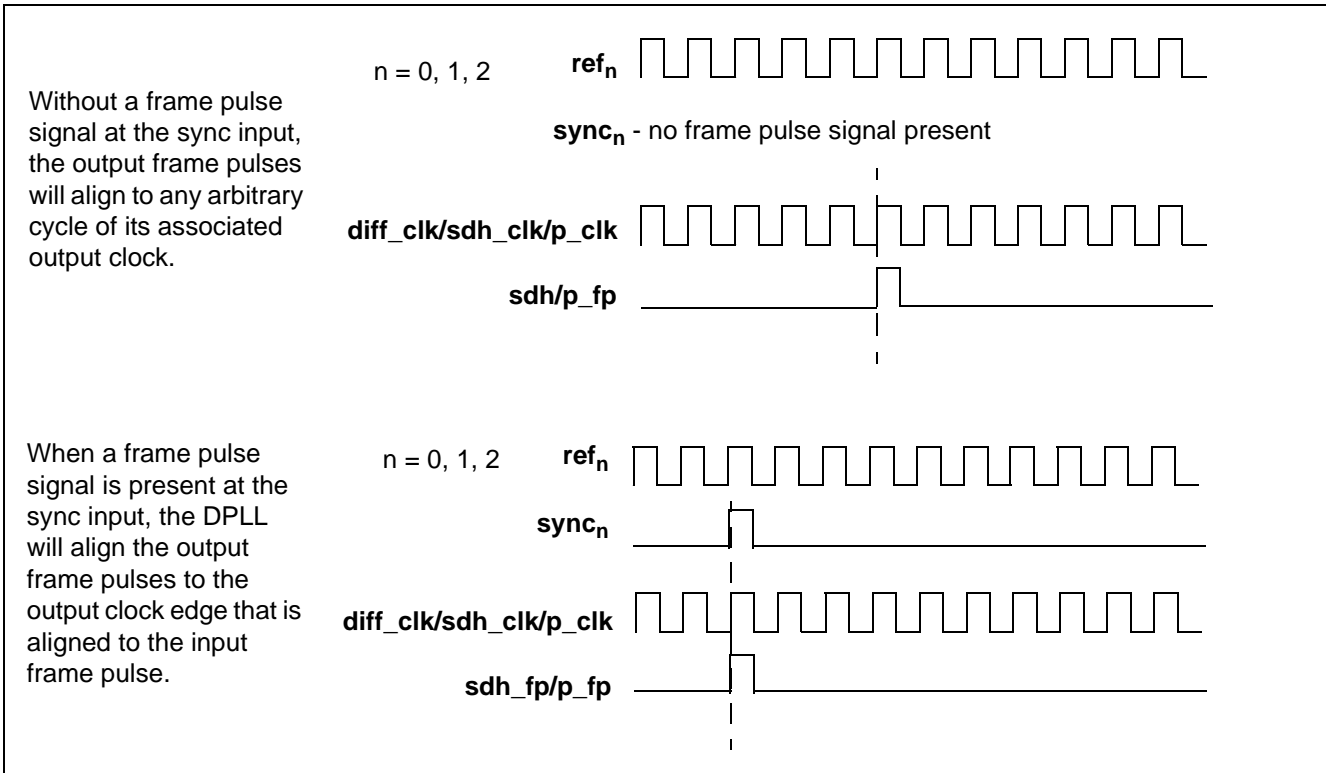

Figure 4 - Output Frame Pulse Alignment

Each of the **ref** inputs accept a single-ended LVCMOS clock with a frequency ranging from 2 kHz to 77.76 MHz. Built-in frequency detection circuitry automatically determines the frequency of the reference if its frequency is within the set of pre-defined frequencies as shown in Table 2. Custom frequencies definable in multiples of 8 kHz are also available.

| |
|------------|
| 2 kHz |
| 8 kHz |
| 64 kHz |
| 1.544 MHz |
| 2.048 MHz |
| 6.48 MHz |
| 8.192 MHz |
| 16.384 MHz |
| 19.44 MHz |
| 38.88 MHz |
| 77.76 MHz |

Table 2 - Set of Pre-Defined Auto-Detect Clock Frequencies

Each of the **sync** inputs accept a single-ended LVCMOS frame pulse. Since alignment is determined from the rising edge of the frame pulse, there is no duty cycle restriction on this input, but there is a minimum pulse width requirement of 5 ns. Frequency detection for the sync inputs is automatic for the supported frame pulse frequencies shown in Table 3.

| |
|---------------------------------------|
| 166.67 Hz (48x 125 μ s frames) |
| 400 Hz |
| 1 kHz |
| 2 kHz |
| 8 kHz |
| 64 kHz |

Table 3 - Set of Pre-Defined Auto-Detect Sync Frequencies

1.4 Ref and Sync Monitoring

All input references (**ref0** to **ref2**) are monitored for frequency accuracy and phase regularity. New references are qualified before they can be selected as a synchronization source, and qualified references are continuously monitored to ensure that they are suitable for synchronization. The process of qualifying a reference depends on four levels of monitoring.

Single Cycle Monitor (SCM)

The SCM block measures the period of each reference clock cycle to detect phase irregularities or a missing clock edge. In general, if the measured period deviates by more than 50% from the nominal period, then an SCM failure (**scm_fail**) is declared.

Coarse Frequency Monitor (CFM)

The CFM block monitors the reference frequency over a measurement period of 30 μ s so that it can quickly detect large changes in frequency. A CFM failure (cfm_fail) is triggered when the frequency has changed by more than 3% or approximately 30000 ppm.

Precise Frequency Monitor (PFM)

The PFM block measures the frequency accuracy of the reference over a 10 second interval. To ensure an accurate frequency measurement, the PFM measurement interval is re-initiated if phase or frequency irregularities are detected by the SCM or CFM. The PFM provides a level of hysteresis between the acceptance range and the rejection range to prevent a failure indication from toggling between valid and invalid for references that are on the edge of the acceptance range.

When determining the frequency accuracy of the reference input, the PFM uses the external oscillator's output frequency (f_{ocsi}) as its point of reference.

Guard Soak Timer (GST)

The GST block mimics the operation of an analog integrator by accumulating failure events from the CFM and the SCM blocks and applying a selectable rate of decay when no failures are detected.

As shown in Figure 5, a GST failure (gst_fail) is triggered when the accumulated failures have reached the upper threshold during the disqualification observation window. When there are no CFM or SCM failures, the accumulator decrements until it reaches its lower threshold during the qualification window.

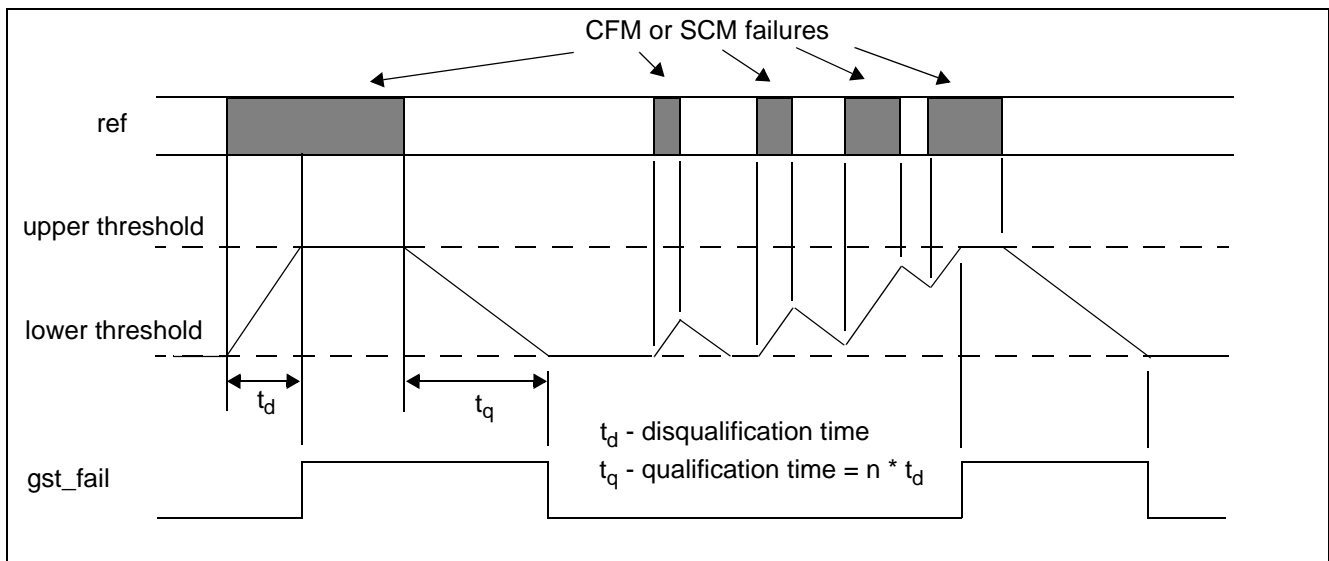

Figure 5 - Behaviour of the Guard Soak Timer during CFM or SCM Failures

Sync Ratio Monitor

All sync inputs (**sync0 to sync2**) are continuously monitored to ensure that there is a correct number of reference clock cycles within the frame pulse period.

1.5 Output Clocks and Frame Pulses

The ZL30122 offers a wide variety of outputs including one low-jitter differential LVPECL clock (**diff_clk_p/n**), one SONET/SDH LVCMOS (**sdh_clk**) output clock and one programmable LVCMOS (**p_clk**) output clock. In addition to the clock outputs, one LVCMOS SONET/SDH frame pulse output (**sdh_fp**) and one LVCMOS programmable frame pulse (**p_fp**) is also available.

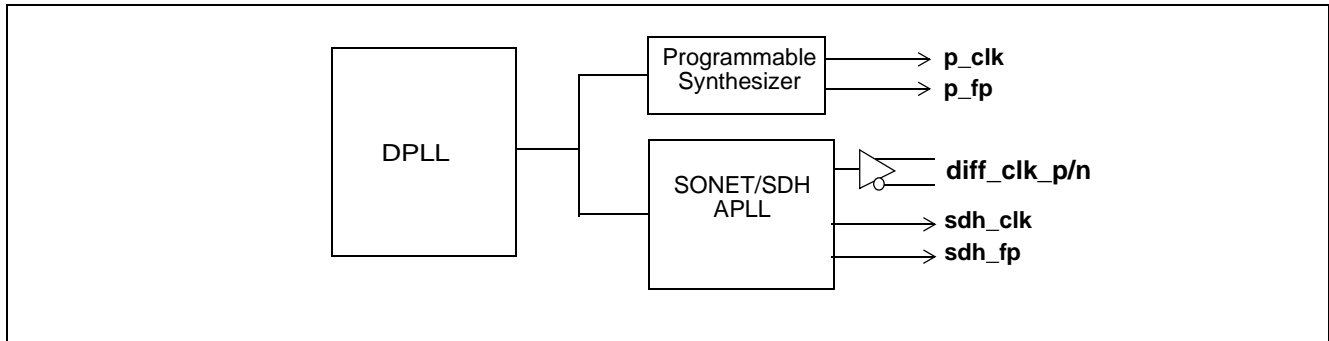

Figure 6 - Output Configuration

The supported frequencies for the output clocks and frame pulses are shown in Table 4.

| diff_clk_p/n (LVPECL) | sdh_clk (LVCMOS) | p_clk (LVCMOS) | sdh_fp, p_fp (LVCMOS) |
|-----------------------|------------------|-----------------------------|-------------------------------|
| 6.48 MHz | 6.48 MHz | 2 kHz | 166.67 Hz (48x 125 μs frames) |
| 19.44 MHz | 9.72 MHz | N * 8 kHz (up to 77.76 MHz) | 400 Hz |
| 38.88 MHz | 12.96 MHz | | 1 kHz |
| 51.84 MHz | 19.44 MHz | | 2 kHz |
| 77.76 MHz | 25.92 MHz | | 4 kHz |
| 155.52 MHz | 38.88 MHz | | 8 kHz |
| 311.04 MHz | 51.84 MHz | | 32 kHz |
| 622.08 MHz | 77.76 MHz | | 64 kHz |

Table 4 - Output Clock and Frame Pulse Frequencies

1.6 Configurable Input-to-Output and Output-to-Output Delays

The ZL30122 allows programmable static delay compensation for controlling input-to-output and output-to-output delays of its clocks and frame pulses.

Both the SONET/SDH APLL and the Programmable Synthesizer can be configured to lead or lag the selected input reference clock using the **DPLL Fine Delay**. The delay is programmed in steps of 119.2 ps with a range of -128 to +127 steps giving a total delay adjustment in the range of -15.26 ns to +15.14 ns. Negative values delay the output clock, positive values advance the output clock.

In addition to the delay introduced by the DPLL Fine Delay, the SONET/SDH APLL and programmable synthesizer have the ability to add their own fine delay adjustments using the **P Fine Delay** and **SDH Fine Delay**. These delays are also programmable in steps of 119.2 ps with a range of -128 to +127 steps.

In addition to these delays, the single-ended output clocks of the SONET/SDH and Programmable synthesizers can be independently offset by 90, 180 and 270 degrees using the **Coarse Delay**, and the SONET/SDH differential outputs can be independently delayed by -1.6 ns, 0 ns, +1.6 ns or +3.2 ns using the **Diff Delay**. The output frame pulses (sdh_clk, p_fp) can be independently offset with respect to each other using the **FP Delay**.

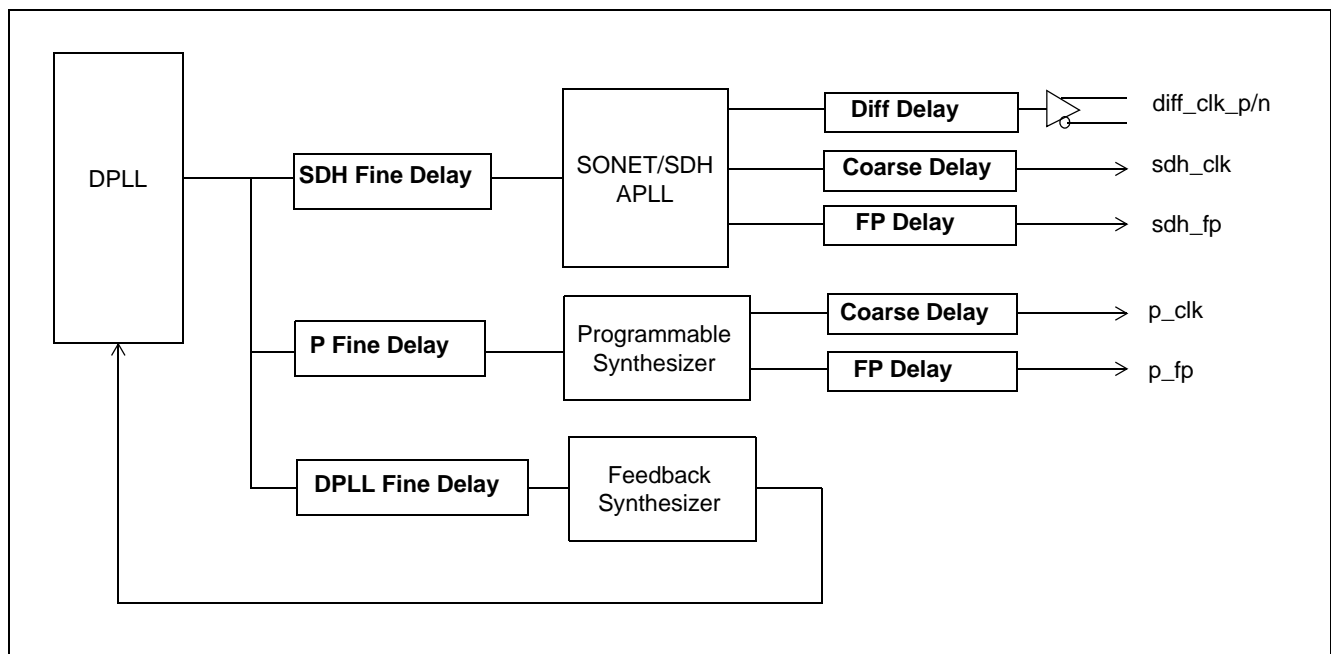

Figure 7 - Phase Delay Adjustments

2.0 Software Configuration

The ZL30122 is mainly controlled by accessing software registers through the serial peripheral interface (SPI). The device can be configured to operate in a highly automated manner which minimizes its interaction with the system's processor, or it can operate in a manual mode where the system processor controls most of the operation of the device.

The following table provides a summary of the registers available for status updates and configuration of the device.

| Addr (Hex) | Register Name | Reset Value (Hex) | Description | Type |
|--------------------------------|---------------------|-------------------|---|--------|
| Miscellaneous Registers | | | | |
| 00 | id_reg | A6 | Chip and version identification and reset ready indication register | R |
| 01 | use_hw_ctrl | 00 | Allows some functions of the device to be controlled by hardware pins | R/W |
| Interrupts | | | | |
| 02 | ref_fail_isr | FF | Reference failure interrupt service register | R |
| 03 | dpll_isr | 70 | DPLL interrupt service register | StickR |
| 04 | Reserved | | Leave as default | |
| 05 | ref_mon_fail_0 | FF | Ref0 and ref1 failure indications | StickR |
| 06 | ref_mon_fail_1 | FF | Ref2 failure indication. | StickR |
| 07 | Reserved | | Leave as default | |
| 08 | Reserved | | Leave as default | |
| 09 | ref_fail_isr_mask | 00 | Reference failure interrupt service register mask | R/W |
| 0A | dpll_isr_mask | 00 | DPLL interrupt service register mask | R/W |
| 0B | Reserved | | Leave as default | |
| 0C | ref_mon_fail_mask_0 | FF | Control register to mask each failure indicator for ref0 and ref1 | R/W |
| 0D | ref_mon_fail_mask_1 | FF | Control register to mask failure indicator for ref2 | R/W |
| 0E | Reserved | | Leave as default | |
| 0F | Reserved | | Leave as default | |
| Reference Monitor Setup | | | | |
| 10 | detected_ref_0 | FF | Ref0 and ref1 auto-detected frequency value status register | R |
| 11 | detected_ref_1 | FF | Ref2 auto-detected frequency value status register | R |
| 12 | Reserved | | Leave as default | R |
| 13 | Reserved | | Leave as default | R |

Table 5 - Register Map

| Addr (Hex) | Register Name | Reset Value (Hex) | Description | Type |
|---------------------|----------------------|--------------------------|---|------|
| 14 | detected_sync_0 | EE | Sync0 and sync1 auto-detected frequency value and sync failure status register | R |
| 15 | detected_sync_1 | 0E | Sync2 auto-detected frequency value and sync valid status register | R |
| 16 | oor_ctrl_0 | 33 | Control register for the ref0 and ref1 out of range limit | R/W |
| 17 | oor_ctrl_1 | 33 | Control register for the ref2 out of range limit | R/W |
| 18 | Reserved | | Leave as default | |
| 19 | Reserved | | Leave as default | |
| 1A | gst_mask | FF | Control register to mask the inputs to the guard soak timer for ref0 - ref2 | R/W |
| 1B | Reserved | | Leave as default | |
| 1C | gst_qualif_time | 1A | Control register for the guard_soak_timer qualification time and disqualification time for the references | R/W |
| DPLL Control | | | | |
| 1D | dpll_ctrl_0 | See Register Description | Control register for the DPLL filter control; phase slope limit, bandwidth and hitless switching | R/W |
| 1E | dpll_ctrl_1 | See Register Description | Holdover update time, filter_out_en, freq_offset_en, revert enable | R/W |
| 1F | dpll_modesel | See Register Description | Control register for the DPLL mode of operation | R/W |
| 20 | dpll_refsel | 00 | DPLL reference selection or reference selection status | R/W |
| 21 | dpll_ref_fail_mask | 3C | Control register to mask each failure indicator (SCM, CFM, PFM and GST) used for automatic reference switching and automatic holdover | R/W |
| 22 | dpll_wait_to_restore | 00 | Control register to indicate the time to restore a previous failed reference | R/W |
| 23 | dpll_ref_rev_ctrl | 00 | Control register for the ref0 to ref2 enable revertive signals | R/W |
| 24 | dpll_ref_pri_ctrl_0 | 10 | Control register for the ref0 and ref1 priority values | R/W |
| 25 | dpll_ref_pri_ctrl_1 | 32 | Control register for the ref2 priority values | R/W |
| 26 | Reserved | | Leave as default | |
| 27 | Reserved | | Leave as default | |

Table 5 - Register Map (continued)

| Addr (Hex) | Register Name | Reset Value (Hex) | Description | Type |
|---|---------------------------|-------------------|---|------|
| 28 | dpll_lock_holdover_status | 04 | DPLL lock and holdover status register | R |
| 29 | Reserved | 03 | Leave as default | R/W |
| 2A - 35 | Reserved | | Leave as default | |
| Programmable Synthesizer Configuration Registers | | | | |
| 36 | p_enable | 8F | Control register to enable the p_clk and p_fp outputs of the programmable synthesizer | R/W |
| 37 | p_run | 0F | Control register to generate p_clk, p_fp | R/W |
| 38 | p_freq_0 | 00 | Control register for the [7:0] bits of the N of N*8k clk | R/W |
| 39 | p_freq_1 | 01 | Control register for the [13:8] bits of the N of N*8k clk | R/W |
| 3A | p_clk_offset90 | 00 | Control register for the p_clk phase position coarse tuning | R/W |
| 3B | Reserved | | Leave as default | |
| 3C | Reserved | | Leave as default | |
| 3D | p_offset_fine | 00 | Control register for the output/output phase alignment fine tuning for the programmable synthesizer | R/W |
| 3E | p_fp_freq | 05 | Control register to select the p_fp frame pulse frequency | R/W |
| 3F | p_fp_type | 83 | Control register to select p_fp type | R/W |
| 40 | p_fp_fine_offset_0 | 00 | Bits [7:0] of the programmable frame pulse phase offset in multiples of 1/262.14 MHz | R/W |
| 41 | p_fp_fine_offset_1 | 00 | Bits [15:8] of the programmable frame pulse phase offset in multiples of 1/262.14 MHz | R/W |
| 42 | p_fp_coarse_offset | 00 | Programmable frame pulse phase offset in multiples of 8 kHz cycles | R/W |
| 43 - 4F | Reserved | | Leave as default | |
| SDH Configuration Registers | | | | |
| 50 | sdh_enable | 8F | Control register to enable sdh_clk and sdh_fp | R/W |
| 51 | sdh_run | 0F | Control register to generate sdh_clk and sdh_fp | R/W |
| 52 | sdh_clk_div | 42 | Control register for the sdh_clk frequency selection | R/W |
| 53 | sdh_clk_offset90 | 00 | Control register for the sdh_clk phase position coarse tuning | R/W |

Table 5 - Register Map (continued)

| Addr (Hex) | Register Name | Reset Value (Hex) | Description | Type |
|--|----------------------|-------------------|--|------|
| 54 | Reserved | | Leave as default | |
| 55 | sdh_offset_fine | 00 | Control register for the output/output phase alignment fine tuning for sdh path | R/W |
| 56 | sdh_fp_freq | 05 | Control register to select the sdh_fp frame pulse frequency | R/W |
| 57 | sdh_fp_type | 23 | Control register to select sdh_fp type | R/W |
| 58 | sdh_fp_fine_offset_0 | 00 | Bits [7:0] of the programmable frame pulse phase offset in multiples of 1/311.04 MHz | R/W |
| 59 | sdh_fp_fine_offset_1 | 00 | Bits [15:8] of the programmable frame pulse phase offset in multiples of 1/311.04 MHz | R/W |
| 5A | sdh_fp_coarse_offset | 00 | Programmable frame pulse phase offset in multiples of 8 kHz cycles | R/W |
| 5B - 5F | Reserved | | Leave as default | |
| Differential Output Configuration | | | | |
| 60 | diff_clk_ctrl | A3 | Control register to enable diff_clk | R/W |
| 61 | diff_clk_sel | 53 | Control register to select the diff_clk frequency | R/W |
| External Feedback Configuration | | | | |
| 62 | Reserved | | Leave as default | |
| 63 | fb_offset_fine | F5 | Control register for the output/output phase alignment fine tuning | R/W |
| 64 | reserved | | | |
| Custom Input Frequencies | | | | |
| 65 | ref_freq_mode_0 | 00 | Control register to set whether to use auto detect, CustomA or CustomB for ref0 to ref2 | R/W |
| 66 | Reserved | | Leave as default | |
| 67 | custA_mult_0 | 00 | Control register for the [7:0] bits of the custom configuration A. This is the N integer for the N*8kHz reference monitoring. | R/W |
| 68 | custA_mult_1 | 00 | Control register for the [13:8] bits of the custom configuration A. This is the N integer for the N*8kHz reference monitoring. | R/W |
| 69 | custA_scm_low | 00 | Control register for the custom configuration A: single cycle SCM low limiter | R/W |
| 6A | custA_scm_high | 00 | Control register for the custom configuration A: single cycle SCM high limiter | R/W |
| 6B | custA_cfm_low_0 | 00 | Control register for the custom configuration A: The [7:0] bits of the single cycle CFM low limit | R/W |

Table 5 - Register Map (continued)

| Addr (Hex) | Register Name | Reset Value (Hex) | Description | Type |
|------------|-----------------|-------------------|--|------|
| 6C | custA_cfm_low_1 | 00 | Control register for the custom configuration A: The [15:0] bits of the single cycle CFM low limit | R/W |
| 6D | custA_cfm_hi_0 | 00 | Control register for the custom configuration A: The [7:0] bits of the single cycle CFM high limit | R/W |
| 6E | custA_cfm_hi_1 | 00 | Control register for the custom configuration A: The [15:0] bits of the single cycle CFM high limiter | R/W |
| 6F | custA_cfm_cycle | 00 | Control register for the custom configuration A: CFM reference monitoring cycles - 1 | R/W |
| 70 | custA_div | 00 | Control register for the custom configuration A: enable the use of ref_div4 for the CFM and PFM inputs | R/W |
| 71 | custB_mult_0 | 00 | Control register for the [7:0] bits of the custom configuration B. This is the 8 k integer for the N*8kHz reference monitoring. | R/W |
| 72 | custB_mult_1 | 00 | Control register for the [13:8] bits of the custom configuration B. This is the 8 k integer for the N*8kHz reference monitoring. | R/W |
| 73 | custB_scm_low | 00 | Control register for the custom configuration B: single cycle SCM low limiter | R/W |
| 74 | custB_scm_high | 00 | Control register for the custom configuration B: single cycle SCM high limiter | R/W |
| 75 | custB_cfm_low_0 | 00 | Control register for the custom configuration B: The [7:0] bits of the single cycle CFM low limiter. | R/W |
| 76 | custB_cfm_low_1 | 00 | Control register for the custom configuration B: The [15:0] bits of the single cycle CFM low limiter. | R/W |
| 77 | custB_cfm_hi_0 | 00 | Control register for the custom configuration B: The [7:0] bits of the single cycle CFM high limiter. | R/W |
| 78 | custB_cfm_hi_1 | 00 | Control register for the custom configuration B: The [15:0] bits of the single cycle CFM high limiter. | R/W |
| 79 | custB_cfm_cycle | 00 | Control register for the custom configuration B: CFM reference monitoring cycles - 1 | R/W |
| 7A | custB_div | 00 | Control register for the custom configuration B: enable the use of ref_div4 for the CFM and PFM inputs | R/W |

Table 5 - Register Map (continued)

| Addr (Hex) | Register Name | Reset Value (Hex) | Description | Type |
|---------------|------------------|-------------------------|-------------|------|
| 7B - 7F | Reserved | | | |

Table 5 - Register Map (continued)

3.0 References

AdvancedTCA, ATCA and the AdvancedTCA and ATCA logos are trademarks of the PCI Industrial Computer Manufacturers Group.

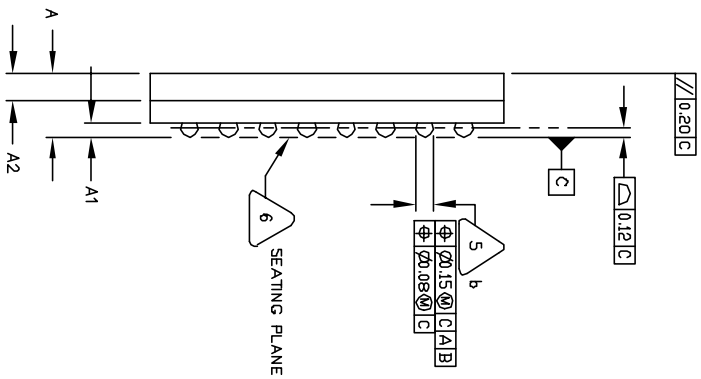
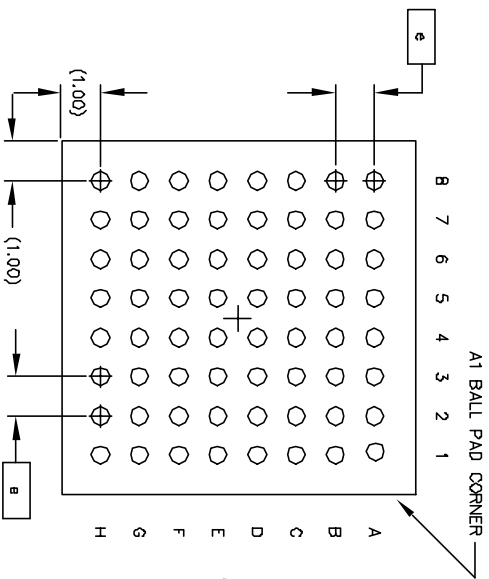
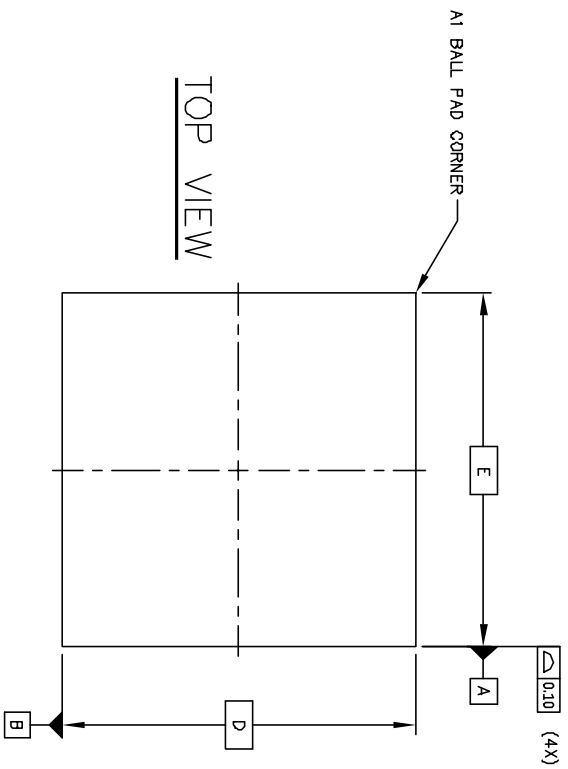

SIDE VIEW

BOTTOM VIEW
64 SOLDER BALLS

| SYMBOL | MILLIMETER | | |
|--------|------------|------|------|
| | MIN | NOM | MAX |
| A | 1.52 | 1.62 | 1.72 |
| A1 | 0.31 | 0.36 | 0.41 |
| A2 | 0.65 | 0.70 | 0.75 |
| b | 0.46 Typ. | | |
| D | 9.00 REF. | | |
| E | 9.00 Ref. | | |
| e | 1.0 Ref | | |
| n | 64 | | |

- 6. PRIMARY DATUM C AND SEATING PLANE ARE DEFINED BY THE SPHERICAL CROWNS OF THE SOLDER BALLS.
- 5. DIMENSION b IS MEASURED AT THE MAXIMUM SOLDER BALL DIAMETER, PARALLEL TO PRIMARY DATUM C.
- 4. THE MAXIMUM ALLOWABLE NUMBER OF SOLDER BALLS IS 64.
- 3. Not to Scale.
- 2. THE BASIC SOLDER BALL GRID PITCH IS 1.00mm.
- 1. ALL DIMENSIONS AND TOLERANCES CONFORM TO ASME Y14.5M-1994.

NOTES: UNLESS OTHERWISE SPECIFIED

© Zarlink Semiconductor 2005 All rights reserved.

| | | | |
|--------|----------|--|--|
| ISSUE | 1 | | |
| ACN | CDCA | | |
| DATE | 15Apr105 | | |
| APPRD. | | | |



Previous package codes

N/A

Package Code GG

Package Outline for 64ball
9x9mm, 1.0 mm Pitch,
4 layer, CABGA

111039



**For more information about all Zarlink products
visit our Web Site at
www.zarlink.com**

Information relating to products and services furnished herein by Zarlink Semiconductor Inc. or its subsidiaries (collectively "Zarlink") is believed to be reliable. However, Zarlink assumes no liability for errors that may appear in this publication, or for liability otherwise arising from the application or use of any such information, product or service or for any infringement of patents or other intellectual property rights owned by third parties which may result from such application or use. Neither the supply of such information or purchase of product or service conveys any license, either express or implied, under patents or other intellectual property rights owned by Zarlink or licensed from third parties by Zarlink, whatsoever. Purchasers of products are also hereby notified that the use of product in certain ways or in combination with Zarlink, or non-Zarlink furnished goods or services may infringe patents or other intellectual property rights owned by Zarlink.

This publication is issued to provide information only and (unless agreed by Zarlink in writing) may not be used, applied or reproduced for any purpose nor form part of any order or contract nor to be regarded as a representation relating to the products or services concerned. The products, their specifications, services and other information appearing in this publication are subject to change by Zarlink without notice. No warranty or guarantee express or implied is made regarding the capability, performance or suitability of any product or service. Information concerning possible methods of use is provided as a guide only and does not constitute any guarantee that such methods of use will be satisfactory in a specific piece of equipment. It is the user's responsibility to fully determine the performance and suitability of any equipment using such information and to ensure that any publication or data used is up to date and has not been superseded. Manufacturing does not necessarily include testing of all functions or parameters. These products are not suitable for use in any medical products whose failure to perform may result in significant injury or death to the user. All products and materials are sold and services provided subject to Zarlink's conditions of sale which are available on request.

Purchase of Zarlink's I²C components conveys a license under the Philips I²C Patent rights to use these components in and I²C System, provided that the system conforms to the I²C Standard Specification as defined by Philips.

Zarlink, ZL, the Zarlink Semiconductor logo and the Legerity logo and combinations thereof, VoiceEdge, VoicePort, SLAC, ISLIC, ISLAC and VoicePath are trademarks of Zarlink Semiconductor Inc.

TECHNICAL DOCUMENTATION - NOT FOR RESALE

Looking for pricing, stock, or lifecycle information?

Click below to explore more details on WIN SOURCE:

 [View ZL30122GGG on WIN SOURCE](#)

 [Microchip Technology](#) Information

Optimize Your Supply Chain with WIN SOURCE Solutions

-  Global Sourcing Solution
-  Obsolete Management
-  Cost Control Management
-  Shortage Management
-  Alternative Solution
-  Excess Inventory Management