

GENERAL DESCRIPTION

The XRT83L38 is a fully integrated Octal (eight channel) long-haul and short-haul line interface unit for T1 (1.544Mbps) 100Ω, E1 (2.048Mbps) 75Ω or 120Ω, or J1 110Ω applications.

In long-haul applications the XRT83L38 accepts signals that have been attenuated from 0 to 36dB at 772kHz in T1 mode (equivalent of 0 to 6000 feet of cable loss) or 0 to 43dB at 1024kHz in E1 mode.

In T1 applications, the XRT83L38 can generate five transmit pulse shapes to meet the short-haul Digital Cross-Connect (DSX-1) template requirements as well as for Channel Service Units (CSU) Line Build Out (LBO) filters of 0dB, -7.5dB -15dB and -22.5dB as required by FCC rules. It also provides programmable transmit pulse generators for each channel that can be used for output pulse shaping allowing performance improvement over a wide variety of conditions (The arbitrary pulse generators are available in both T1 and E1 modes).

The XRT83L38 provides both a parallel **Host** microprocessor interface as well as a **Hardware** mode for programming and control.

Both the B8ZS and HDB3 encoding and decoding functions are selectable as well as AMI. An on-chip

crystal-less jitter attenuator with a 32 or 64 bit FIFO can be placed either in the receive or the transmit path with loop bandwidths of less than 3Hz. The XRT83L38 provides a variety of loop-back and diagnostic features as well as transmit driver short circuit detection and receive loss of signal monitoring. It supports internal impedance matching for 75Ω, 100Ω, 110Ω and 120Ω for both transmitter and receiver. In the absence of the power supply, the transmit outputs and receive inputs are tri-stated allowing for redundancy applications. The chip includes an integrated programmable clock multiplier that can synthesize T1 or E1 master clocks from a variety of external clock sources.

APPLICATIONS

- T1 Digital Cross-Connects (DSX-1)
- ISDN Primary Rate Interface
- CSU/DSU E1/T1/J1 Interface
- T1/E1/J1 LAN/WAN Routers
- Public switching Systems and PBX Interfaces
- T1/E1/J1 Multiplexer and Channel Banks

Features (See Page 2)

FIGURE 1. BLOCK DIAGRAM OF THE XRT83L38 T1/E1/J1 LIU (HOST MODE)

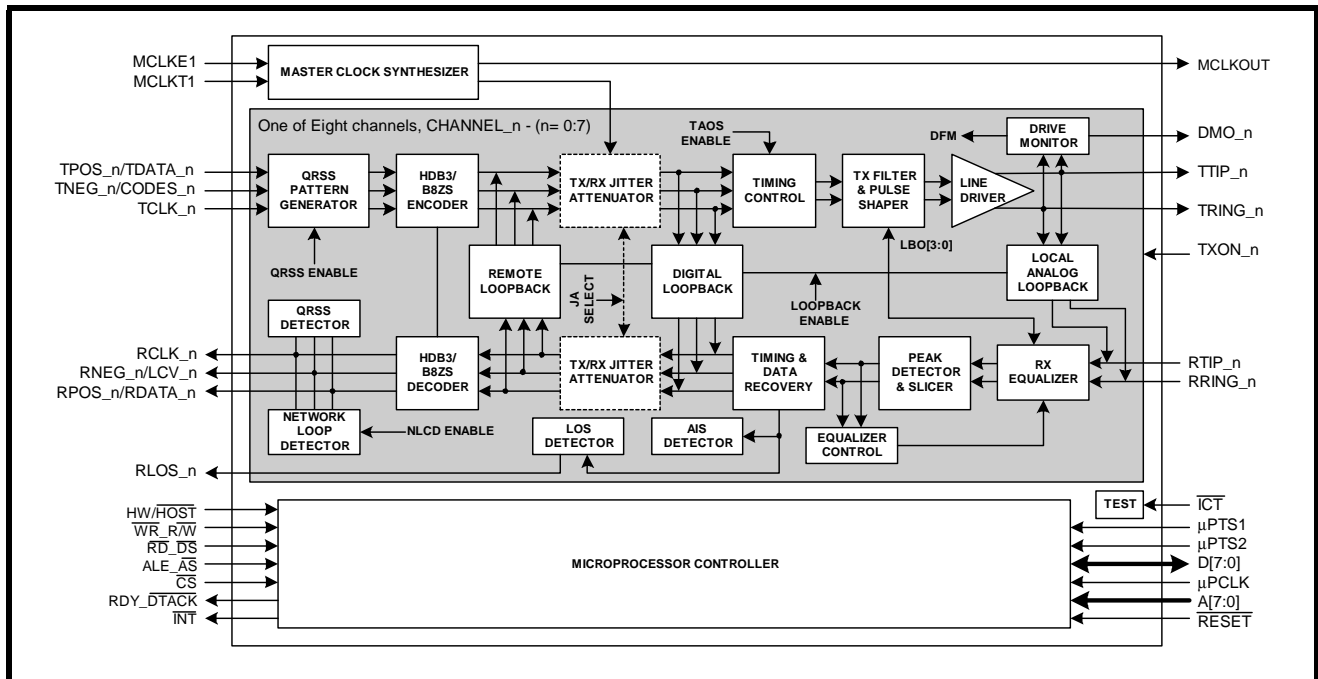
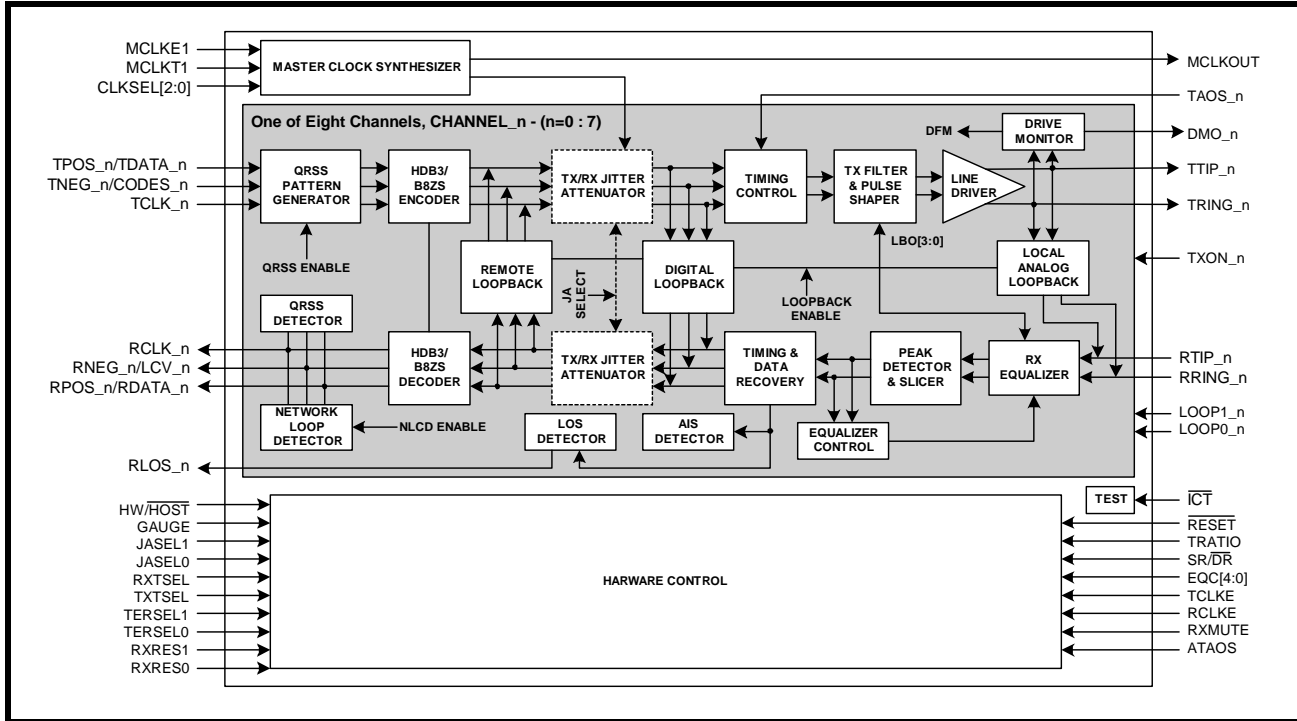

FIGURE 2. BLOCK DIAGRAM OF THE XRT83L38 T1/E1/J1 LIU (HARDWARE MODE)



FEATURES

- Fully integrated eight channel long-haul or short-haul transceivers for E1,T1 or J1 applications
- Adaptive Receive Equalizer for up to 36dB cable attenuation
- Programable Transmit Pulse Shaper for E1,T1 or J1 short-haul interfaces
- Five fixed transmit pulse settings for T1 short-haul applications plus a fully programmable waveform generator for transmit output pulse shaping available for both T1 and E1 modes
- Transmit Line Build-Outs (LBO) for T1 long-haul application from 0dB to -22.5dB in three 7.5dB steps
- Selectable receiver sensitivity from 0 to 36dB cable loss for T1 @772kHz and 0 to 43dB for E1 @1024kHz
- Receive monitor mode handles 0 to 29dB resistive attenuation along with 0 to 6dB of cable attenuation for E1 and 0 to 3dB of cable attenuation for T1 modes
- Supports 75Ω and 120Ω (E1), 100Ω (T1) and 110Ω (J1) applications
- Internal and/or external impedance matching for 75Ω, 100Ω, 110Ω and 120Ω
- Tri-State transmit output and receive input capability for redundancy applications
- Provides High Impedance for Tx and Rx during power off
- Transmit return loss meets or exceeds ETSI 300-166 standard
- On-chip digital clock recovery circuit for high input jitter tolerance
- Crystal-less digital jitter attenuator with 32-bit or 64-bit FIFO selectable either in transmit or receive path
- On-chip frequency multiplier generates T1 or E1 Master clocks from variety of external clock sources
- High receiver interference immunity
- On-chip transmit short-circuit protection and limiting, and driver fail monitor output (DMO)
- Receive loss of signal (RLOS) output

- On-chip HDB3/B8ZS/AMI encoder/decoder functions
- QRSS pattern generator and detection for testing and monitoring
- Error and Bipolar Violation Insertion and Detection
- Receiver Line Attenuation Indication Output in 1dB steps
- Network Loop-Code Detection for automatic Loop-Back Activation/Deactivation
- Transmit All Ones (TAOS) and In-Band Network Loop Up and Down code generators
- Supports Local Analog, Remote, Digital and Dual Loop-Back Modes
- Meets or exceeds T1 and E1 short-haul and long-haul network access specifications in ITU G.703, G.775, G.736 and G.823; TR-TSY-000499; ANSI T1.403 and T1.408; ETSI 300-166 and AT&T Pub 62411
- Supports both **Hardware** and **Host** (parallel Microprocessor) interface for programming
- Programmable Interrupt
- Low power dissipation
- Logic inputs accept either 3.3V or 5V levels
- Single 3.3V Supply Operation
- 225 ball BGA package
- -40°C to +85°C Temperature Range

ORDERING INFORMATION

PART NUMBER	PACKAGE	OPERATING TEMPERATURE RANGE
XRT83L381B	225 Ball BGA	-40°C to +85°C

FIGURE 3. PACKAGE PIN OUT

	1	2	3	4	5	6	7	8	9	10	11	12	13	14	15	16	17	18
A	NC1	RNEG_0	TCLK_1	TPOS_1	TAOS_2	RDY_DTACK	ALE_AS	CLKSEL0	DVDD	A[1]	A[3]	A[7]	TXON_0	JASEL0	TCLK_2	RLOS_3	RCLK_3	NC4
B	NC5	RPOS_0	RCLK_0	TCLK_0	TNEG_1	TAOS_1	CS	CLKSEL1	DGND	A[2]	A[6]	TXON_3	JASEL1	TNEG_2	TNEG_3	RNEG_3	RPOS_3	NC12
C	RTIP_0	RVDD_0	RLOS_0	TNEG_0	TPOS_0	TAOS_3	RD_DS	CLKSEL2	DGND_PDR	A[0]	A[5]	TXON_2	DMO_3	TCLK_3	DMO_2	TTIP_3	TGND_3	RTIP_3
D	RRING_0	RGND_0	TGND_0	DMO_1	DMO_0	TAOS_0	WR_RW	DGND_DR	DVDD_DR	DVDD_PDR	A[4]	TXON_1	TNEG_2	TPOS_3	RPOS_2	RVDD_3	RGND_3	RRING_3
E	NC6	TRING_0	TTIP_0	TVDD_0	RVDD_1										TGND_2	TRING_3	TVDD_3	NC11
F	RRING_1	TGND_1	TRING_1	TVDD_1											TRING_2	TVDD_2	TTIP_2	RRING_2
G	RTIP_1	RPOS_1	RGND_1	TTIP_1											DGND_DR	RVDD_2	RGND_2	RTIP_2
H	MCLKOUT	RNEG_1	RCLK_1	RLOS_1											RLOS_2	RCLK_2	DGND_uP	RNEG_2
J	MCLK1	VDDPLL_2	VDDPLL_1	DVDD_DR											RLOS_6	PTS1	AGND_BIAS	GAUGE
K	MCLKT1	DGND_DR	GNDPLL_1	SR_DR											DVDD_DR	RXON	AVDD_BIAS	DVDD_uP
L	RTIP_5	RLOS_5	RCLK_5	GNDPLL_2											PTS2	INT	RPOS_6	RTIP_6
M	RRING_5	RGND_5	RPOS_5	RNEG_5											RCLK_6	RNEG_6	RGND_6	RRING_6
N	NC7	TTIP_5	RVDD_5	TRING_5											TVDD_6	TTIP_6	RVDD_6	NC10
P	TVDD_5	TRING_4	TGND_5	DMO_5											TVDD_7	TTIP_7	TRING_7	NC9
R	NC8	TTIP_4	TGND_4	TVDD_4	DMO_4	TAOS_7	D[0]	DGND_PDR	DVDD_DR	RXRES1	TERSEL0	TXON_6	TXON_7	TNEG_7	TRING_6	TGND_7	RGND_7	RRING_7
T	RRING_4	RGND_4	TCLK_4	RNEG_4	TCLK_5	TAOS_4	D[7]	RESET	DGND_DR	HW_HOST	TERSEL1	RXMUTE	uPCLK	TPOS_7	RLOS_7	TGND_6	RPOS_7	RTIP_7
U	RTIP_4	RPOS_4	RCLK_4	TNEG_4	TPOS_5	TAOS_5	D[6]	D[2]	D[1]	DVDD_PDR	RXTSEL	TEST	TXON_5	TNEG_6	TCLK_7	RCLK_7	DMO_6	RVDD_7
V	NC2	RVDD_4	RLOS_4	TPOS_4	TNEG_5	TAOS_6	D[5]	D[4]	D[3]	RXRES0	TXTSEL	ICT	TXON_4	DMO_7	TPOS_6	TCLK_6	RNEG_7	NC3

XRT83L38
(Top View)
225 Ball BGA

TABLE OF CONTENTS

GENERAL DESCRIPTION	1
APPLICATIONS	1
FIGURE 1. BLOCK DIAGRAM OF THE XRT83L38 T1/E1/J1 LIU (HOST MODE).....	1
FIGURE 2. BLOCK DIAGRAM OF THE XRT83L38 T1/E1/J1 LIU (HARDWARE MODE).....	2
FEATURES	2
ORDERING INFORMATION	3
FIGURE 3. PACKAGE PIN OUT.....	4
TABLE OF CONTENTS	1
PIN DESCRIPTION BY FUNCTION	5
RECEIVE SECTIONS.....	5
TRANSMITTER SECTIONS.....	7
MICROPROCESSOR INTERFACE.....	11
JITTER ATTENUATOR.....	14
CLOCK SYNTHESIZER.....	14
ALARM FUNCTIONS/REDUNDANCY SUPPORT.....	16
POWER AND GROUND.....	19
PINS ONLY AVAILABLE IN BGA PACKAGE.....	21
FUNCTIONAL DESCRIPTION	22
MASTER CLOCK GENERATOR.....	22
FIGURE 4. TWO INPUT CLOCK SOURCE.....	22
FIGURE 5. ONE INPUT CLOCK SOURCE.....	22
TABLE 1: MASTER CLOCK GENERATOR.....	23
RECEIVER	23
RECEIVER INPUT.....	23
RECEIVE MONITOR MODE.....	24
RECEIVER LOSS OF SIGNAL (RLOS).....	24
FIGURE 6. SIMPLIFIED DIAGRAM OF -15dB T1/E1 SHORT HAUL MODE AND RLOS CONDITION.....	24
FIGURE 7. SIMPLIFIED DIAGRAM OF -29dB T1/E1 GAIN MODE AND RLOS CONDITION.....	25
FIGURE 8. SIMPLIFIED DIAGRAM OF -36dB T1/E1 LONG HAUL MODE AND RLOS CONDITION.....	25
FIGURE 9. SIMPLIFIED DIAGRAM OF EXTENDED RLOS MODE (E1 ONLY).....	26
RECEIVE HDB3/B8ZS DECODER.....	26
RECOVERED CLOCK (RCLK) SAMPLING EDGE.....	26
FIGURE 10. RECEIVE CLOCK AND OUTPUT DATA TIMING.....	27
JITTER ATTENUATOR.....	27
GAPPED CLOCK (JA MUST BE ENABLED IN THE TRANSMIT PATH).....	27
TABLE 2: MAXIMUM GAP WIDTH FOR MULTIPLEXER/MAPPER APPLICATIONS.....	27
ARBITRARY PULSE GENERATOR FOR T1 AND E1.....	28
FIGURE 11. ARBITRARY PULSE SEGMENT ASSIGNMENT.....	28
TRANSMITTER	28
DIGITAL DATA FORMAT.....	28
TRANSMIT CLOCK (TCLK) SAMPLING EDGE.....	28
FIGURE 12. TRANSMIT CLOCK AND INPUT DATA TIMING.....	29
TRANSMIT HDB3/B8ZS ENCODER.....	29
TABLE 3: EXAMPLES OF HDB3 ENCODING.....	29
TABLE 4: EXAMPLES OF B8ZS ENCODING.....	29
DRIVER FAILURE MONITOR (DMO).....	29
TRANSMIT PULSE SHAPER & LINE BUILD OUT (LBO) CIRCUIT.....	30
TABLE 5: RECEIVE EQUALIZER CONTROL AND TRANSMIT LINE BUILD-OUT SETTINGS.....	30
TRANSMIT AND RECEIVE TERMINATIONS	31
RECEIVER (CHANNELS 0 - 7).....	31
Internal Receive Termination Mode.....	31

TABLE 6: RECEIVE TERMINATION CONTROL	32
FIGURE 13. SIMPLIFIED DIAGRAM FOR THE INTERNAL RECEIVE AND TRANSMIT TERMINATION MODE.....	32
TABLE 7: RECEIVE TERMINATIONS.....	32
FIGURE 14. SIMPLIFIED DIAGRAM FOR T1 IN THE EXTERNAL TERMINATION MODE (RXTSEL= 0).....	33
FIGURE 15. SIMPLIFIED DIAGRAM FOR E1 IN EXTERNAL TERMINATION MODE (RXTSEL= 0).....	34
TRANSMITTER (CHANNELS 0 - 7).....	34
Transmit Termination Mode.....	34
TABLE 8: TRANSMIT TERMINATION CONTROL	34
TABLE 9: TERMINATION SELECT CONTROL.....	34
External Transmit Termination Mode	34
TABLE 10: TRANSMIT TERMINATION CONTROL	35
TABLE 11: TRANSMIT TERMINATIONS.....	35
REDUNDANCY APPLICATIONS.....	35
TYPICAL REDUNDANCY SCHEMES	36
FIGURE 16. SIMPLIFIED BLOCK DIAGRAM OF THE TRANSMIT SECTION FOR 1:1 & 1+1 REDUNDANCY	37
FIGURE 17. SIMPLIFIED BLOCK DIAGRAM - RECEIVE SECTION FOR 1:1 AND 1+1 REDUNDANCY	37
FIGURE 18. SIMPLIFIED BLOCK DIAGRAM - TRANSMIT SECTION FOR N+1 REDUNDANCY.....	38
FIGURE 19. SIMPLIFIED BLOCK DIAGRAM - RECEIVE SECTION FOR N+1 REDUNDANCY.....	39
PATTERN TRANSMIT AND DETECT FUNCTION.....	40
TABLE 12: PATTERN TRANSMISSION CONTROL	40
TRANSMIT ALL ONES (TAOS).....	40
NETWORK LOOP CODE DETECTION AND TRANSMISSION	40
TABLE 13: LOOP-CODE DETECTION CONTROL	40
TRANSMIT AND DETECT QUASI-RANDOM SIGNAL SOURCE (TDQRSS).....	41
LOOP-BACK MODES	42
TABLE 14: LOOP-BACK CONTROL IN HARDWARE MODE.....	42
TABLE 15: LOOP-BACK CONTROL IN HOST MODE.....	42
LOCAL ANALOG LOOP-BACK (ALOOP)	42
FIGURE 20. LOCAL ANALOG LOOP-BACK SIGNAL FLOW.....	42
REMOTE LOOP-BACK (RLOOP).....	43
FIGURE 21. REMOTE LOOP-BACK MODE WITH JITTER ATTENUATOR SELECTED IN RECEIVE PATH.....	43
FIGURE 22. REMOTE LOOP-BACK MODE WITH JITTER ATTENUATOR SELECTED IN TRANSMIT PATH	43
DIGITAL LOOP-BACK (DLOOP).....	44
FIGURE 23. DIGITAL LOOP-BACK MODE WITH JITTER ATTENUATOR SELECTED IN TRANSMIT PATH	44
DUAL LOOP-BACK	44
FIGURE 24. SIGNAL FLOW IN DUAL LOOP-BACK MODE	44
MICROPROCESSOR PARALLEL INTERFACE.....	45
TABLE 16: MICROPROCESSOR INTERFACE SIGNAL DESCRIPTION	45
MICROPROCESSOR REGISTER TABLES	46
TABLE 17: MICROPROCESSOR REGISTER ADDRESS	46
TABLE 18: MICROPROCESSOR REGISTER BIT DESCRIPTION	46
MICROPROCESSOR REGISTER DESCRIPTIONS	50
TABLE 19: MICROPROCESSOR REGISTER #0, BIT DESCRIPTION	50
TABLE 20: MICROPROCESSOR REGISTER #1, BIT DESCRIPTION	51
TABLE 21: MICROPROCESSOR REGISTER #2, BIT DESCRIPTION	53
TABLE 22: MICROPROCESSOR REGISTER #3, BIT DESCRIPTION	55
TABLE 23: MICROPROCESSOR REGISTER #4, BIT DESCRIPTION	56
TABLE 24: MICROPROCESSOR REGISTER #5, BIT DESCRIPTION	58
TABLE 25: MICROPROCESSOR REGISTER #6, BIT DESCRIPTION	60
TABLE 26: MICROPROCESSOR REGISTER #7, BIT DESCRIPTION	61
TABLE 27: MICROPROCESSOR REGISTER #8, BIT DESCRIPTION	62
TABLE 28: MICROPROCESSOR REGISTER #9, BIT DESCRIPTION	62
TABLE 29: MICROPROCESSOR REGISTER #10, BIT DESCRIPTION	63
TABLE 30: MICROPROCESSOR REGISTER #11, BIT DESCRIPTION	63
TABLE 31: MICROPROCESSOR REGISTER #12, BIT DESCRIPTION	64
TABLE 32: MICROPROCESSOR REGISTER #13, BIT DESCRIPTION	64
TABLE 33: MICROPROCESSOR REGISTER #14, BIT DESCRIPTION	65

TABLE 34: MICROPROCESSOR REGISTER #15, BIT DESCRIPTION	65
TABLE 35: MICROPROCESSOR REGISTER #128, BIT DESCRIPTION	66
CLOCK SELECT REGISTER.....	67
FIGURE 25. REGISTER 0X81H SUB REGISTERS.....	67
TABLE 36: MICROPROCESSOR REGISTER #129, BIT DESCRIPTION	67
TABLE 37: MICROPROCESSOR REGISTER #130, BIT DESCRIPTION	69
TABLE 38: MICROPROCESSOR REGISTER #131, BIT DESCRIPTION	71
TABLE 39: MICROPROCESSOR REGISTER #192, BIT DESCRIPTION	72
ELECTRICAL CHARACTERISTICS.....	73
TABLE 40: ABSOLUTE MAXIMUM RATINGS	73
TABLE 41: DC DIGITAL INPUT AND OUTPUT ELECTRICAL CHARACTERISTICS.....	73
TABLE 42: XRT83L38 POWER CONSUMPTION	73
TABLE 43: E1 RECEIVER ELECTRICAL CHARACTERISTICS	74
TABLE 44: T1 RECEIVER ELECTRICAL CHARACTERISTICS.....	75
TABLE 45: E1 TRANSMIT RETURN LOSS REQUIREMENT	75
TABLE 46: E1 TRANSMITTER ELECTRICAL CHARACTERISTICS.....	76
TABLE 47: T1 TRANSMITTER ELECTRICAL CHARACTERISTICS.....	76
FIGURE 26. ITU G.703 PULSE TEMPLATE	77
TABLE 48: TRANSMIT PULSE MASK SPECIFICATION.....	77
FIGURE 27. DSX-1 PULSE TEMPLATE (NORMALIZED AMPLITUDE)	78
TABLE 49: DSX1 INTERFACE ISOLATED PULSE MASK AND CORNER POINTS.....	78
TABLE 50: AC ELECTRICAL CHARACTERISTICS	79
FIGURE 28. TRANSMIT CLOCK AND INPUT DATA TIMING	79
FIGURE 29. RECEIVE CLOCK AND OUTPUT DATA TIMING.....	80
MICROPROCESSOR INTERFACE I/O TIMING	80
Intel Interface Timing - Asynchronous.....	80
FIGURE 30. INTEL ASYNCHRONOUS PROGRAMMED I/O INTERFACE TIMING	80
TABLE 51: ASYNCHRONOUS MODE 1 - INTEL 8051 AND 80188 INTERFACE TIMING	81
Motorola Asynchronous Interface Timing.....	82
FIGURE 31. MOTOROLA 68K ASYNCHRONOUS PROGRAMMED I/O INTERFACE TIMING	82
TABLE 52: ASYNCHRONOUS - MOTOROLA 68K - INTERFACE TIMING SPECIFICATION.....	82
FIGURE 32. MICROPROCESSOR INTERFACE TIMING - RESET PULSE WIDTH	82
PACKAGE DIMENSIONS.....	83
225 BALL PLASTIC BALL GRID ARRAY (BOTTOM VIEW)	83
(19.0 x 19.0 x 1.0MM).....	83
ORDERING INFORMATION.....	84
REVISIONS.....	84

PIN DESCRIPTION BY FUNCTION

RECEIVE SECTIONS

SIGNAL NAME	LEAD #	TYPE	DESCRIPTION
RLOS_0	C3	O	<p>Receiver Loss of Signal for Channel_0: This output signal goes "High" for at least one RCLK_0 cycle to indicate loss of signal at the receive 0 input. RLOS will remain "High" for the entire duration of the Loss of Signal detected by the receiver logic.</p> <p>SEE "RECEIVER LOSS OF SIGNAL (RLOS)" ON PAGE 24.</p>
RLOS_1	H4		Receiver Loss of Signal for Channel _1
RLOS_2	H15		Receiver Loss of Signal for Channel _2
RLOS_3	A16		Receiver Loss of Signal for Channel _3
RLOS_4	V3		Receiver Loss of Signal for Channel _4
RLOS_5	L2		Receiver Loss of Signal for Channel _5
RLOS_6	J15		Receiver Loss of Signal for Channel _6
RLOS_7	T15		Receiver Loss of Signal for Channel _7
RCLK_0	B3	O	Receiver Clock Output for Channel _0
RCLK_1	H3		Receiver Clock Output for Channel _1
RCLK_2	H16		Receiver Clock Output for Channel _2
RCLK_3	A17		Receiver Clock Output for Channel _3
RCLK_4	U3		Receiver Clock Output for Channel _4
RCLK_5	L3		Receiver Clock Output for Channel _5
RCLK_6	M15		Receiver Clock Output for Channel _6
RCLK_7	U16		Receiver Clock Output for Channel _7
RNEG_0	A2	O	<p>Receiver Negative Data Output for Channel_0 - Dual-Rail mode This signal is the receive negative-rail output data.</p>
LCV_0	A2		<p>Line Code Violation Output for Channel_0 - Single-Rail mode This signal goes "High" for one RCLK_0 cycle to indicate a code violation is detected in the received data of Channel _0. If AMI coding is selected, every bipolar violation received will cause this pin to go "High".</p>
RNEG_1	H2		Receiver Negative Data Output for Channel _1
LCV_1			Line Code Violation Output for Channel _1
RNEG_2	H18		Receiver Negative Data Output for Channel _2
LCV_2			Line Code Violation Output for Channel _2
RNEG_3	B16		Receiver Negative Data Output for Channel _3
LCV_3			Line Code Violation Output for Channel _3
RNEG_4	T4		Receiver Negative Data Output for Channel _4
LCV_4			Line Code Violation Output for Channel _4
RNEG_5	M4		Receiver Negative Data Output for Channel _5
LCV_5			Line Code Violation Output for Channel _5
RNEG_6	M16		Receiver Negative Data Output for Channel _6
LCV_6			Line Code Violation Output for Channel _6
RNEG_7	V17		Receiver Negative Data Output for Channel _7
LCV_7			Line Code Violation Output for Channel _7

SIGNAL NAME	LEAD #	TYPE	DESCRIPTION
RPOS_0	B2	O	Receiver Positive Data Output for Channel _0 - Dual-Rail mode This signal is the receive positive-rail output data sent to the Framer.
RDATA_0	B2		Receiver NRZ Data Output for Channel _0 - Single-Rail mode This signal is the receive output data.
RPOS_1	G2		Receiver Positive Data Output for Channel _1
RDATA_1			Receiver NRZ Data Output for Channel _1
RPOS_2	D15		Receiver Positive Data Output for Channel _2
RDATA_2			Receiver NRZ Data Output for Channel _2
RPOS_3	B17		Receiver Positive Data Output for Channel _3
RDATA_3			Receiver NRZ Data Output for Channel _3
RPOS_4	U2		Receiver Positive Data Output for Channel _4
RDATA_4			Receiver NRZ Data Output for Channel _4
RPOS_5	M3		Receiver Positive Data Output for Channel _5
RDATA_5			Receiver NRZ Data Output for Channel _5
RPOS_6	L17		Receiver Positive Data Output for Channel _6
RDATA_6			Receiver NRZ Data Output for Channel _6
RPOS_7	T17		Receiver Positive Data Output for Channel _7
RDATA_7			Receiver NRZ Data Output for Channel _7
RTIP_0	C1	I	Receiver Differential Tip Input for Channel _0 Positive differential receive input from the line
RTIP_1	G1		Receiver Differential Tip Input for Channel _1
RTIP_2	G18		Receiver Differential Tip Input for Channel _2
RTIP_3	C18		Receiver Differential Tip Input for Channel _3
RTIP_4	U1		Receiver Differential Tip Input for Channel _4
RTIP_5	L1		Receiver Differential Tip Input for Channel _5
RTIP_6	L18		Receiver Differential Tip Input for Channel _6
RTIP_7	T18		Receiver Differential Tip Input for Channel _7
RRING_0	D1	I	Receiver Differential Ring Input for Channel _0 Negative differential receive input from the line
RRING_1	F1		Receiver Differential Ring Input for Channel _1
RRING_2	F18		Receiver Differential Ring Input for Channel _2
RRING_3	D18		Receiver Differential Ring Input for Channel _3
RRING_4	T1		Receiver Differential Ring Input for Channel _4
RRING_5	M1		Receiver Differential Ring Input for Channel _5
RRING_6	M18		Receiver Differential Ring Input for Channel _6
RRING_7	R18		Receiver Differential Ring Input for Channel _7
RXMUTE	T12	I	Receive Data Muting When a LOS condition occurs, the outputs RPOS_n/RNEG_n will be muted, (forced to ground) to prevent data chattering. Tie this pin "Low" to disable the muting function. NOTES: 1. This pin is internally pulled "High" with a 50kΩ resistor. 2. In Hardware mode , all receive channels share the same RXMUTE control function.

OCTAL T1/E1/J1 LH/SH TRANSCEIVER WITH CLOCK RECOVERY AND JITTER ATTENUATOR

SIGNAL NAME	LEAD #	TYPE	DESCRIPTION															
RXRES1 RXRES0	R10 V10	I	<p>Receive External Resistor Control Pins - Hardware mode Receive External Resistor Control Pin 1: Receive External Resistor Control Pin 0: These pins determine the value of the external Receive fixed resistor according to the following table:</p> <table border="1" style="margin-left: auto; margin-right: auto;"> <thead> <tr> <th>RXRES1</th> <th>RXRES0</th> <th>Required Fixed External RX Resistor</th> </tr> </thead> <tbody> <tr> <td>0</td> <td>0</td> <td>No External Fixed Resistor</td> </tr> <tr> <td>0</td> <td>1</td> <td>240Ω</td> </tr> <tr> <td>1</td> <td>0</td> <td>210Ω</td> </tr> <tr> <td>1</td> <td>1</td> <td>150Ω</td> </tr> </tbody> </table> <p><i>NOTE: These pins are internally pulled "Low" with a 50kΩ resistor.</i></p>	RXRES1	RXRES0	Required Fixed External RX Resistor	0	0	No External Fixed Resistor	0	1	240Ω	1	0	210Ω	1	1	150Ω
RXRES1	RXRES0	Required Fixed External RX Resistor																
0	0	No External Fixed Resistor																
0	1	240Ω																
1	0	210Ω																
1	1	150Ω																
RCLK_E μPTS1	J16 J16	I	<p>Receive Clock Edge - Hardware mode Set this pin "High" to sample RPOS_N/RNEG_n on the falling edge of RCLK_n. With this pin tied "Low", output data are updated on the rising edge of RCLK_n. Microprocessor Type Select Input pin 1 - Host mode This pin along with μPTS2 (pin 128) is used to select the microprocessor type. SEE "MICROPROCESSOR TYPE SELECT INPUT PINS - HOST MODE:" ON PAGE 12. <i>NOTE: This pin is internally pulled "Low" with a 50kΩ resistor.</i></p>															

TRANSMITTER SECTIONS

SIGNAL NAME	LEAD #	TYPE	DESCRIPTION
TCLK_E μPTS2	L15 L15	I	<p>Transmit Clock Edge - Hardware mode Set this pin "High" to sample transmit input data on the rising edge of TCLK_n. With this pin tied "Low", input data are sampled on the falling edge of TCLK_n. Microprocessor Type Select Input pin 2 - Host mode This pin along with μPTS1 (pin 133) selects the microprocessor type. SEE "MICROPROCESSOR TYPE SELECT INPUT PINS - HOST MODE:" ON PAGE 12. <i>NOTE: This pin is internally pulled "Low" with a 50kΩ resistor.</i></p>
TTIP_0 TTIP_1 TTIP_2 TTIP_3 TTIP_4 TTIP_5 TTIP_6 TTIP_7	E3 G4 F17 C16 R2 N2 N16 P16	O	<p>Transmitter Tip Output for Channel_0 Positive differential transmit output to the line. Transmitter Tip Output for Channel_1 Transmitter Tip Output for Channel_2 Transmitter Tip Output for Channel_3 Transmitter Tip Output for Channel_4 Transmitter Tip Output for Channel_5 Transmitter Tip Output for Channel_6 Transmitter Tip Output for Channel_7</p>

SIGNAL NAME	LEAD #	TYPE	DESCRIPTION
TRING_0	E2	O	Transmitter Ring Output for Channel _0 Negative differential transmit output to the line.
TRING_1	F3		Transmitter Ring Output for Channel _1
TRING_2	F15		Transmitter Ring Output for Channel _2
TRING_3	E16		Transmitter Ring Output for Channel _3
TRING_4	P2		Transmitter Ring Output for Channel _4
TRING_5	N4		Transmitter Ring Output for Channel _5
TRING_6	R15		Transmitter Ring Output for Channel _6
TRING_7	P17		Transmitter Ring Output for Channel _7
TPOS_0	C5	I	Transmitter Positive Data Input for Channel _0 - Dual-Rail mode This signal is the positive-rail input data for transmitter 0.
TDATA_0			Transmitter 0 Data Input - Single-Rail mode This pin is used as the NRZ input data for transmitter 0.
TPOS_1	A4		Transmitter Positive Data Input for Channel _1
TDATA_1			Transmitter 1 Data Input
TPOS_2	B14		Transmitter Positive Data Input for Channel _2
TDATA_2			Transmitter 2 Data Input
TPOS_3	D14		Transmitter Positive Data Input for Channel _3
TDATA_3			Transmitter 3 Data Input
TPOS_4	V4		Transmitter Positive Data Input for Channel _4
TDATA_4			Transmitter 4 Data Input
TPOS_5	U5		Transmitter Positive Data Input for Channel _5
TDATA_5			Transmitter 5 Data Input
TPOS_6	V15		Transmitter Positive Data Input for Channel _6
TDATA_6			Transmitter 6 Data Input
TPOS_7	T14		Transmitter Positive Data Input for Channel _7
TDATA_7			Transmitter 7 Data Input
			<i>NOTE: Internally pulled "Low" with a 50kΩ resistor for each channel.</i>

SIGNAL NAME	LEAD #	TYPE	DESCRIPTION
TNEG_0	C4	I	<p>Transmitter Negative NRZ Data Input for Channel _0</p> <p>Dual-Rail mode This signal is the negative-rail input data for transmitter 0.</p> <p>Single-Rail mode This pin can be left unconnected.</p>
CODES_0	C4		<p>Coding Select for Channel _0 - Hardware mode and Single-Rail mode Connecting this pin "Low" enables HDB3 in E1 or B8ZS in T1 encoding and decoding for Channel _0. Connecting this pin "High" selects AMI data format.</p>
TNEG_1	B5		<p>Transmitter Negative NRZ Data Input for Channel _1</p>
CODES_1			<p>Coding Select for Channel _1</p>
TNEG_2	D13		<p>Transmitter Negative NRZ Data Input for Channel _2</p>
CODES_2			<p>Coding Select for Channel _2</p>
TNEG_3	B15		<p>Transmitter Negative NRZ Data Input for Channel _3</p>
CODES_3			<p>Coding Select for Channel _3</p>
TNEG_4	U4		<p>Transmitter Negative NRZ Data Input for Channel _4</p>
CODES_4			<p>Coding Select for Channel _4</p>
TNEG_5	V5		<p>Transmitter Negative NRZ Data Input for Channel _5</p>
CODES_5			<p>Coding Select for Channel _5</p>
TNEG_6	U14		<p>Transmitter Negative NRZ Data Input for Channel _6</p>
CODES_6			<p>Coding Select for Channel _6</p>
TNEG_7	R14		<p>Transmitter Negative NRZ Data Input for Channel _7</p>
CODES_7			<p>Coding Select for Channel _7</p> <p><i>NOTE: Internally pulled "Low" with a 50kΩ resistor for each channel.</i></p>
TCLK_0	B4	I	<p>Transmitter Clock Input for Channel _0 - Host mode and Hardware mode E1 rate at 2.048MHz ± 50ppm. T1 rate at 1.544MHz ± 32ppm. During normal operation TCLK_0 is used for sampling input data at TPOS_0/ TDATA_0 and TNEG_0/CODES_0 while MCLK is used as the timing reference for the transmit pulse shaping circuit.</p>
TCLK_1	A3		<p>Transmitter Clock Input for Channel _1</p>
TCLK_2	A15		<p>Transmitter Clock Input for Channel _2</p>
TCLK_3	C14		<p>Transmitter Clock Input for Channel _3</p>
TCLK_4	T3		<p>Transmitter Clock Input for Channel _4</p>
TCLK_5	T5		<p>Transmitter Clock Input for Channel _5</p>
TCLK_6	V16		<p>Transmitter Clock Input for Channel _6</p>
TCLK_7	U15		<p>Transmitter Clock Input for Channel _7</p> <p><i>NOTE: Internally pulled "Low" with a 50kΩ resistor for all channels.</i></p>

SIGNAL NAME	LEAD #	TYPE	DESCRIPTION
TAOS_0	D6	I	<p>Transmit All Ones for Channel _0 - Hardware mode</p> <p>Setting this pin "High" enables the transmission of an "All Ones" Pattern from Channel _0. A "Low" level stops the transmission of the "All Ones" Pattern.</p> <p>Transmit All Ones for Channel _1</p> <p>Transmit All Ones for Channel _2</p> <p>Transmit All Ones for Channel _3</p> <p>Transmit All Ones for Channel _4</p> <p>Transmit All Ones for Channel _5</p> <p>Transmit All Ones for Channel _6</p> <p>Transmit All Ones for Channel _7</p> <p><i>NOTE: Internally pulled "Low" with a 50kΩ resistor for all channels.</i></p>
TAOS_1	B6		
TAOS_2	A5		
TAOS_3	C6		
TAOS_4	T6		
TAOS_5	U6		
TAOS_6	V6		
TAOS_7	R6		
TXON_0	A13	I	<p>Transmitter Turn On for Channel _0</p> <p>Hardware mode</p> <p>Setting this pin "High" turns on the Transmit and Receive Sections of Channel _0. When TXON_0 = "0" then TTIP_0 and TRING_0 driver outputs will be tri-stated.</p> <p>In Host mode</p> <p>The TXON_n bits in the channel control registers turn each channel Transmit and Receive section ON or OFF. However, control of the on/off function can be transferred to the Hardware pins by setting the TXONCNTL bit (bit 7) to "1" in the register at address hex 0x82.</p> <p>Transmitter Turn On for Channel _1</p> <p>Transmitter Turn On for Channel _2</p> <p>Transmitter Turn On for Channel _3</p> <p>Transmitter Turn On for Channel _4</p> <p>Transmitter Turn On for Channel _5</p> <p>Transmitter Turn On for Channel _6</p> <p>Transmitter Turn On for Channel _7</p> <p><i>NOTE: Internally pulled "Low" with a 50kΩ resistor for all channels.</i></p>
TXON_1	D12		
TXON_2	C12		
TXON_3	B12		
TXON_4	V13		
TXON_5	U13		
TXON_6	R12		
TXON_7	R13		

MICROPROCESSOR INTERFACE

SIGNAL NAME	LEAD #	TYPE	DESCRIPTION
HW_HOST	T10	I	<p>Mode Control Input This pin selects Hardware or Host mode. Leave this pin unconnected or tie "High" to select Hardware mode. For Host mode, this pin must be tied "Low". <i>NOTE: Internally pulled "High" with a 50kΩ resistor.</i></p>
WR_R/W	D7	I	<p>Write Input (Read/Write) - Host mode: Intel bus timing: A "Low" pulse on \overline{WR} selects a write operation when \overline{CS} pin is "Low". Motorola bus timing: A "High" pulse on R/\overline{W} selects a read operation and a "Low" pulse on R/\overline{W} selects a write operation when \overline{CS} is "Low".</p>
EQC0	D7		<p>Equalizer Control Input pin 0 - Hardware mode Pins EQC0, EQC1, EQC2, EQC3 and EQC4 select the Receive Equalizer and Transmitter Line Build Out. SEE "RECEIVE EQUALIZER CONTROL AND TRANSMIT LINE BUILD-OUT SETTINGS" ON PAGE 30. <i>NOTE: Internally pulled "Low" with a 50kΩ resistor.</i></p>
RD_DS	C7	I	<p>Read Input (Data Strobe) - Host mode Intel bus timing: A "Low" pulse on \overline{RD} selects a read operation when the \overline{CS} pin is "Low". Motorola bus timing: A "Low" pulse on \overline{DS} indicates a read or write operation when the \overline{CS} pin is "Low".</p>
EQC1	C7		<p>Equalizer Control Input pin 1 - Hardware mode Pins EQC0, EQC1, EQC2, EQC3 and EQC4 select the Receive Equalizer and Transmitter Line Build Out. SEE "RECEIVE EQUALIZER CONTROL AND TRANSMIT LINE BUILD-OUT SETTINGS" ON PAGE 30. <i>NOTE: Internally pulled "Low" with a 50kΩ resistor.</i></p>
ALE_AS	A7	I	<p>Address Latch Input (Address Strobe) - Host mode Intel bus timing: The address inputs are latched into the internal register on the falling edge of ALE. Motorola bus timing: The address inputs are latched into the internal register on the falling edge of AS.</p>
EQC2	A7		<p>Equalizer Control Input pin 2 - Hardware mode Pins EQC0, EQC1, EQC2, EQC3 and EQC4 select the Receive Equalizer and Transmitter Line Build Out. SEE "RECEIVE EQUALIZER CONTROL AND TRANSMIT LINE BUILD-OUT SETTINGS" ON PAGE 30. <i>NOTE: Internally pulled "Low" with a 50kΩ resistor.</i></p>
CS	B7	I	<p>Chip Select Input - Host mode: This signal must be "Low" in order to access the parallel port.</p>
EQC3	B7		<p>Equalizer Control Input pin 3 - Hardware mode: Pins EQC0, EQC1, EQC2, EQC3 and EQC4 select the Receive Equalizer and Transmitter Line Build Out. SEE "RECEIVE EQUALIZER CONTROL AND TRANSMIT LINE BUILD-OUT SETTINGS" ON PAGE 30. <i>NOTE: Internally pulled "Low" with a 50kΩ resistor.</i></p>

SIGNAL NAME	LEAD #	TYPE	DESCRIPTION															
RDY_DTACK	A6	O	Ready Output (Data Transfer Acknowledge Output) - Host mode Intel bus timing: RDY is asserted "High" to indicate the device has completed a read or write operation. Motorola bus timing: DTACK is asserted "Low" to indicate the device has completed a read or write cycle.															
EQC4	A6	I	Equalizer Control Input pin 4 - Hardware mode Pins EQC0, EQC1, EQC2, EQC3 and EQC4 select the Receive Equalizer and Transmitter Line Build Out. SEE "RECEIVE EQUALIZER CONTROL AND TRANSMIT LINE BUILD-OUT SETTINGS" ON PAGE 30. NOTE: Internally pulled "Low" with a 50kΩ resistor.															
μPTS1 μPTS2	J16 L15	I	Microprocessor Type Select Input Pins - Host Mode: Microprocessor Type Select Input Bit 1 Microprocessor Type Select Input Bit 2															
			<table border="1"> <thead> <tr> <th>μPTS2</th> <th>μPTS1</th> <th>μP Type</th> </tr> </thead> <tbody> <tr> <td>0</td> <td>0</td> <td>68HC11, 8051, 80C188 (async.)</td> </tr> <tr> <td>0</td> <td>1</td> <td>Motorola 68K (async.)</td> </tr> <tr> <td>1</td> <td>0</td> <td>Intel x86 (sync.)</td> </tr> <tr> <td>1</td> <td>1</td> <td>Motorola 860 (sync.)</td> </tr> </tbody> </table>	μPTS2	μPTS1	μP Type	0	0	68HC11, 8051, 80C188 (async.)	0	1	Motorola 68K (async.)	1	0	Intel x86 (sync.)	1	1	Motorola 860 (sync.)
μPTS2	μPTS1	μP Type																
0	0	68HC11, 8051, 80C188 (async.)																
0	1	Motorola 68K (async.)																
1	0	Intel x86 (sync.)																
1	1	Motorola 860 (sync.)																
RCLKE	J16		Receive Clock Edge - Hardware mode SEE "RECEIVE CLOCK EDGE - HARDWARE MODE" ON PAGE 7.															
TCLKE	L15		Transmit Clock Edge - Hardware mode SEE "TRANSMIT CLOCK EDGE - HARDWARE MODE" ON PAGE 7. NOTE: These pins are internally pulled "Low" with a 50kΩ resistor.															
D[7] D[6] D[5] D[4] D[3] D[2] D[1] D[0]	T7 U7 V7 V8 V9 U8 U9 R7	I/O	Microprocessor Read/Write Data Bus Pins - Host mode Data Bus[7] Data Bus[6] Data Bus[5] Data Bus[4] Data Bus[3] Data Bus[2] Data Bus[1] Data Bus[0]															
LOOP1_4 LOOP0_4 LOOP1_5 LOOP0_5 LOOP1_6 LOOP0_6 LOOP1_7 LOOP0_7	T7 U7 V7 V8 V9 U8 U9 R7		Loop-back Control Pins, Bits [1:0] Channel_[7:4] - Hardware Mode Pins 67-74 and 173-180 control which Loop-Back mode is selected per channel. SEE "LOOP-BACK CONTROL PINS, BITS [1:0] CHANNEL_[7:0]" ON PAGE 17. NOTE: Internally pulled "Low" with a 50kΩ resistor for all channels.															

SIGNAL NAME	LEAD #	TYPE	DESCRIPTION
A[7] A[6] A[5] A[4] A[3] A[2] A[1] A[0] LOOP1_3 LOOP0_3 LOOP1_2 LOOP0_2 LOOP1_1 LOOP0_1 LOOP1_0 LOOP0_0	A12 B11 C11 D11 A11 B10 A10 C10 A12 B11 C11 D11 A11 B10 A10 C10	I	<p>Microprocessor Interface Address Bus Pins - Host mode:</p> <p>Microprocessor Interface Address Bus[7] Microprocessor Interface Address Bus[6] Microprocessor Interface Address Bus[5] Microprocessor Interface Address Bus[4] Microprocessor Interface Address Bus[3] Microprocessor Interface Address Bus[2] Microprocessor Interface Address Bus[1] Microprocessor Interface Address Bus[0]</p> <p>Loop-back Control Pins, Bits [1:0] Channel_[3:0] In Hardware mode, pins 67-74 and 173-180 control which Loop-Back mode is selected per channel. SEE"LOOP-BACK CONTROL PINS, BITS [1:0] CHANNEL_[7:0]" ON PAGE 17.</p> <p><i>NOTE: These pins are internally pulled "Low" with a 50kΩ resistor.</i></p>
μPCLK ATAOS	T13 T13	I	<p>Microprocessor Clock Input - Host Mode: Input clock for synchronous microprocessor operation. Maximum clock rate is 54 MHz.</p> <p><i>NOTE: This pin is internally pulled "Low" with a 50kΩ resistor for asynchronous microprocessor interface when no clock is present.</i></p> <p>Automatic Transmit "All Ones" - Hardware mode This pin functions as an Automatic Transmit "All Ones". SEE"AUTOMATIC TRANSMIT "ALL ONES" PATTERN - HARDWARE MODE" ON PAGE 16.</p>
INT TRATIO	L16 L16	O I	<p>Interrupt Output - Host mode This pin goes "Low" to indicate an alarm condition has occurred within the device. Interrupt generation can be globally disabled by setting the GIE bit to a "0" in the command control register.</p> <p>Transmitter Transformer Ratio Select - Hardware mode The function of this pin is to select the transmitter transformer ratio. SEE"TRANSMITTER TRANSFORMER RATIO SELECT - HARDWARE MODE" ON PAGE 16.</p> <p><i>NOTE: This pin is an open drain output and requires an external 10kΩ pull-up resistor.</i></p>

JITTER ATTENUATOR

SIGNAL NAME	LEAD #	TYPE	DESCRIPTION																																
JASEL0 JASEL1	A14 B13	I	<p>Jitter Attenuator Select Pins Hardware Mode Jitter Attenuator select Bit 0 Jitter Attenuator select Bit 1</p> <p>JASEL[1:0] pins are used to place the jitter attenuator in the transmit path, the receive path or to disable it.</p> <table border="1"> <thead> <tr> <th rowspan="2">JASEL1</th> <th rowspan="2">JASEL0</th> <th rowspan="2">JA Path</th> <th colspan="2">JA BW Hz</th> <th rowspan="2">FIFO Size</th> </tr> <tr> <th>T1</th> <th>E1</th> </tr> </thead> <tbody> <tr> <td>0</td> <td>0</td> <td>Disabled</td> <td>----</td> <td>----</td> <td>-----</td> </tr> <tr> <td>0</td> <td>1</td> <td>Transmit</td> <td>3</td> <td>10</td> <td>32/32</td> </tr> <tr> <td>1</td> <td>0</td> <td>Receive</td> <td>3</td> <td>10</td> <td>32/32</td> </tr> <tr> <td>1</td> <td>1</td> <td>Receive</td> <td>3</td> <td>1.5</td> <td>64/64</td> </tr> </tbody> </table> <p>NOTE: These pins are internally pulled "Low" with 50kΩ resistors.</p>	JASEL1	JASEL0	JA Path	JA BW Hz		FIFO Size	T1	E1	0	0	Disabled	----	----	-----	0	1	Transmit	3	10	32/32	1	0	Receive	3	10	32/32	1	1	Receive	3	1.5	64/64
JASEL1	JASEL0	JA Path	JA BW Hz				FIFO Size																												
			T1	E1																															
0	0	Disabled	----	----	-----																														
0	1	Transmit	3	10	32/32																														
1	0	Receive	3	10	32/32																														
1	1	Receive	3	1.5	64/64																														

CLOCK SYNTHESIZER

SIGNAL NAME	LEAD #	TYPE	DESCRIPTION
MCLKOUT	H1	O	<p>Synthesized Master Clock Output</p> <p>This signal is the output of the Master Clock Synthesizer PLL which is at T1 or E1 rate based upon the mode of operation.</p>
MCLKT1	K1	I	<p>T1 Master Clock Input</p> <p>This signal is an independent 1.544MHz clock for T1 systems with accuracy better than ±50ppm and duty cycle within 40% to 60%. MCLKT1 is used in the T1 mode.</p> <p>NOTES:</p> <ol style="list-style-type: none"> All channels of the XRT83L38 must be operated at the same clock rate, either T1, E1 or J1. See pin 26 description for further explanation for the usage of this pin. Internally pulled "Low" with a 50kΩ resistor.
MCLKE1	J1	I	<p>E1 Master Clock Input</p> <p>A 2.048MHz clock for with an accuracy of better than ±50ppm and a duty cycle of 40% to 60% can be provided at this pin.</p> <p>In systems that have only one master clock source available (E1 or T1), that clock should be connected to both MCLKE1 and MCLKT1 inputs for proper operation.</p> <p>NOTES:</p> <ol style="list-style-type: none"> All channels of the XRT83L38 must be operated at the same clock rate, either T1, E1 or J1. Internally pulled "Low" with a 50kΩ resistor.

SIGNAL NAME	LEAD #	TYPE	DESCRIPTION																																																																																																																																					
CLKSEL0 CLKSEL1 CLKSEL2	A8 B8 C8	I	<p>Clock Select inputs for Master Clock Synthesizer - Hardware mode</p> <p>CLKSEL[2:0] are input signals to a programmable frequency synthesizer that can be used to generate a master clock from an external accurate clock source according to the table below.</p> <p>In Hardware mode, the MCLKRATE control signal is generated from the state of EQC[4:0] inputs.</p> <p>In Host mode, the state of these pins are ignored and the master frequency PLL is controlled by the corresponding interface bits. See Table 36 register address 10000001</p> <table border="1"> <thead> <tr> <th>MCLKE1 kHz</th> <th>MCLKT1 kHz</th> <th>CLKSEL2</th> <th>CLKSEL1</th> <th>CLKSEL0</th> <th>MCLKRATE</th> <th>CLKOUT/ kHz</th> </tr> </thead> <tbody> <tr><td>2048</td><td>2048</td><td>0</td><td>0</td><td>0</td><td>0</td><td>2048</td></tr> <tr><td>2048</td><td>2048</td><td>0</td><td>0</td><td>0</td><td>1</td><td>1544</td></tr> <tr><td>2048</td><td>1544</td><td>0</td><td>0</td><td>0</td><td>0</td><td>2048</td></tr> <tr><td>1544</td><td>1544</td><td>0</td><td>0</td><td>1</td><td>1</td><td>1544</td></tr> <tr><td>1544</td><td>1544</td><td>0</td><td>0</td><td>1</td><td>0</td><td>2048</td></tr> <tr><td>2048</td><td>1544</td><td>0</td><td>0</td><td>1</td><td>1</td><td>1544</td></tr> <tr><td>8</td><td>X</td><td>0</td><td>1</td><td>0</td><td>0</td><td>2048</td></tr> <tr><td>8</td><td>X</td><td>0</td><td>1</td><td>0</td><td>1</td><td>1544</td></tr> <tr><td>16</td><td>X</td><td>0</td><td>1</td><td>1</td><td>0</td><td>2048</td></tr> <tr><td>16</td><td>X</td><td>0</td><td>1</td><td>1</td><td>1</td><td>1544</td></tr> <tr><td>56</td><td>X</td><td>1</td><td>0</td><td>0</td><td>0</td><td>2048</td></tr> <tr><td>56</td><td>X</td><td>1</td><td>0</td><td>0</td><td>1</td><td>1544</td></tr> <tr><td>64</td><td>X</td><td>1</td><td>0</td><td>1</td><td>0</td><td>2048</td></tr> <tr><td>64</td><td>X</td><td>1</td><td>0</td><td>1</td><td>1</td><td>1544</td></tr> <tr><td>128</td><td>X</td><td>1</td><td>1</td><td>0</td><td>0</td><td>2048</td></tr> <tr><td>128</td><td>X</td><td>1</td><td>1</td><td>0</td><td>1</td><td>1544</td></tr> <tr><td>256</td><td>X</td><td>1</td><td>1</td><td>1</td><td>0</td><td>2048</td></tr> <tr><td>256</td><td>X</td><td>1</td><td>1</td><td>1</td><td>1</td><td>1544</td></tr> </tbody> </table> <p>NOTE: These pins are internally pulled "Low" with a 50kΩ resistor.</p>	MCLKE1 kHz	MCLKT1 kHz	CLKSEL2	CLKSEL1	CLKSEL0	MCLKRATE	CLKOUT/ kHz	2048	2048	0	0	0	0	2048	2048	2048	0	0	0	1	1544	2048	1544	0	0	0	0	2048	1544	1544	0	0	1	1	1544	1544	1544	0	0	1	0	2048	2048	1544	0	0	1	1	1544	8	X	0	1	0	0	2048	8	X	0	1	0	1	1544	16	X	0	1	1	0	2048	16	X	0	1	1	1	1544	56	X	1	0	0	0	2048	56	X	1	0	0	1	1544	64	X	1	0	1	0	2048	64	X	1	0	1	1	1544	128	X	1	1	0	0	2048	128	X	1	1	0	1	1544	256	X	1	1	1	0	2048	256	X	1	1	1	1	1544
MCLKE1 kHz	MCLKT1 kHz	CLKSEL2	CLKSEL1	CLKSEL0	MCLKRATE	CLKOUT/ kHz																																																																																																																																		
2048	2048	0	0	0	0	2048																																																																																																																																		
2048	2048	0	0	0	1	1544																																																																																																																																		
2048	1544	0	0	0	0	2048																																																																																																																																		
1544	1544	0	0	1	1	1544																																																																																																																																		
1544	1544	0	0	1	0	2048																																																																																																																																		
2048	1544	0	0	1	1	1544																																																																																																																																		
8	X	0	1	0	0	2048																																																																																																																																		
8	X	0	1	0	1	1544																																																																																																																																		
16	X	0	1	1	0	2048																																																																																																																																		
16	X	0	1	1	1	1544																																																																																																																																		
56	X	1	0	0	0	2048																																																																																																																																		
56	X	1	0	0	1	1544																																																																																																																																		
64	X	1	0	1	0	2048																																																																																																																																		
64	X	1	0	1	1	1544																																																																																																																																		
128	X	1	1	0	0	2048																																																																																																																																		
128	X	1	1	0	1	1544																																																																																																																																		
256	X	1	1	1	0	2048																																																																																																																																		
256	X	1	1	1	1	1544																																																																																																																																		

ALARM FUNCTIONS/REDUNDANCY SUPPORT

SIGNAL NAME	LEAD #	TYPE	DESCRIPTION
GAUGE	J18	I	<p>Twisted Pair Cable Wire Gauge Select - Hardware Mode</p> <p>Connect this pin "High" to select 26 Gauge wire. Connect this pin "Low" to select 22 and 24 gauge wire for all channels.</p> <p><i>NOTE: Internally pulled "Low" with a 50kΩ resistor.</i></p>
DMO_0	D5	O	<p>Driver Failure Monitor Channel _0:</p> <p>This pin transitions "High" if a short circuit condition is detected in the transmit driver of Channel _0, or no transmit output pulse is detected for more than 128 TCLK_0 cycles.</p>
DMO_1	D4		Driver Failure Monitor Channel _1
DMO_2	C15		Driver Failure Monitor Channel _2
DMO_3	C13		Driver Failure Monitor Channel _3
DMO_4	R5		Driver Failure Monitor Channel _4
DMO_5	P4		Driver Failure Monitor Channel _5
DMO_6	U17		Driver Failure Monitor Channel _6
DMO_7	V14		Driver Failure Monitor Channel _7
ATAOS	T13	I	<p>Automatic Transmit "All Ones" Pattern - Hardware Mode</p> <p>A "High" level on this pin enables the automatic transmission of an "All Ones" AMI pattern from the transmitter of any channel that the receiver of that channel has detected an LOS condition. A "Low" level on this pin disables this function.</p> <p><i>Note: All channels share the same ATAOS control function.</i></p>
μPCLK	T13		<p>Microprocessor Clock Input - Host mode</p> <p>SEE "MICROPROCESSOR CLOCK INPUT - HOST MODE:" ON PAGE 13.</p> <p><i>NOTE: This pin is internally pulled "Low" for asynchronous microprocessor interface when no clock is present.</i></p>
TRATIO	L16	I	<p>Transmitter Transformer Ratio Select - Hardware mode</p> <p>In external termination mode (TXTSEL = 0), setting this pin "High" selects a transformer ratio of 1:2 for the transmitter. A "Low" on this pin sets the transmitter transformer ratio to 1:2.45. In the internal termination mode the transmitter transformer ratio is permanently set to 1:2 and the state of this pin is ignored.</p>
INT	L16	O	<p>Interrupt Output - Host mode</p> <p>This pin is asserted "Low" to indicate an alarm condition. SEE "INTERRUPT OUTPUT - HOST MODE" ON PAGE 13.</p> <p><i>NOTE: This pin is an open drain output and requires an external 10kΩ pull-up resistor.</i></p>
RESET	T8	I	<p>Hardware Reset (Active "Low"):</p> <p>When this pin is tied "Low" for more than 10μs, the device is put in the reset state.</p> <p>Exar recommends initiating a Hardware reset upon power up.</p> <p><i>NOTE: This pin is internally pulled "High" with a 50kΩ resistor.</i></p>
SR/DR	K4	I	<p>Single-Rail/Dual-Rail Data Format:</p> <p>Connect this pin "Low" to select transmit and receive data format in Dual-Rail mode. In this mode, HDB3 or B8ZS encoder and decoder are not available.</p> <p>Connect this pin "High" to select single-rail data format.</p> <p><i>NOTE: Internally pulled "Low" with a 50kΩ resistor.</i></p>

SIGNAL NAME	LEAD #	TYPE	DESCRIPTION															
LOOP1_0	A10	I	<p>Loop-back Control Pins, Bits [1:0] Channel_[7:0]</p> <p>Loop-back Control bit 1, Channel _0</p> <p>Loop-back Control bit 0, Channel _0</p> <p>Loop-back Control bit 1, Channel _1</p> <p>Loop-back Control bit 0, Channel _1</p> <p>Loop-back Control bit 1, Channel _2</p> <p>Loop-back Control bit 0, Channel _2</p> <p>Loop-back Control bit 1, Channel _3</p> <p>Loop-back Control bit 0, Channel _3</p> <p>Loop-back Control bit 1, Channel _4</p> <p>Loop-back Control bit 0, Channel _4</p> <p>Loop-back Control bit 1, Channel _5</p> <p>Loop-back Control bit 0, Channel _5</p> <p>Loop-back Control bit 1, Channel _6</p> <p>Loop-back Control bit 0, Channel _6</p> <p>Loop-back Control bit 1, Channel _7</p> <p>Loop-back Control bit 0, Channel _7</p> <p>In Hardware mode, these pins control the Loop-Back mode for each channel_n per the following table.</p> <table border="1"> <thead> <tr> <th>LOOP1_n</th> <th>LOOP0_n</th> <th>MODE</th> </tr> </thead> <tbody> <tr> <td>0</td> <td>0</td> <td>Normal Mode No Loop-Back Channel_n</td> </tr> <tr> <td>0</td> <td>1</td> <td>Local Loop-Back Channel_n</td> </tr> <tr> <td>1</td> <td>0</td> <td>Remote Loop-Back Channel_n</td> </tr> <tr> <td>1</td> <td>1</td> <td>Digital Loop-Back Channel_n</td> </tr> </tbody> </table>	LOOP1_n	LOOP0_n	MODE	0	0	Normal Mode No Loop-Back Channel_n	0	1	Local Loop-Back Channel_n	1	0	Remote Loop-Back Channel_n	1	1	Digital Loop-Back Channel_n
LOOP1_n	LOOP0_n			MODE														
0	0			Normal Mode No Loop-Back Channel_n														
0	1			Local Loop-Back Channel_n														
1	0			Remote Loop-Back Channel_n														
1	1			Digital Loop-Back Channel_n														
LOOP0_0	C10																	
LOOP1_1	A11																	
LOOP0_1	B10																	
LOOP1_2	C11																	
LOOP0_2	D11																	
LOOP1_3	A12																	
LOOP0_3	B11																	
LOOP1_4	T7																	
LOOP0_4	U7																	
LOOP1_5	V7																	
LOOP0_5	V8																	
LOOP1_6	V9																	
LOOP0_6	U8																	
LOOP1_7	U9																	
LOOP0_7	R7																	
A[1]	A10		<p>Microprocessor Address A[7:0] and Data Bus Pins D[7:0] - Host mode</p> <p>These pins are microprocessor address and data bus pins. SEE "MICROPROCESSOR INTERFACE ADDRESS BUS PINS - HOST MODE:" ON PAGE 13. and see "Microprocessor Read/Write Data Bus Pins - Host mode" on page 12.</p> <p>NOTE: These pins are internally pulled "Low" with a 50kΩ resistor.</p>															
A[0]	C10																	
A[3]	A11																	
A[2]	B10																	
A[5]	C11																	
A[4]	D11																	
A[7]	A12																	
A[6]	B11																	
D[7]	T7																	
D[6]	U7																	
D[5]	V7																	
D[4]	V8																	
D[3]	V9																	
D[2]	U8																	
D[1]	U9																	
D[0]	R7																	

SIGNAL NAME	LEAD #	TYPE	DESCRIPTION						
EQC4	A6	I	<p>Equalizer Control Input 4 - Hardware mode</p> <p>This pin together with pins EQC[3:0] is used to control the transmit pulse shaping, transmit line build-out (LBO) and receive monitoring while operating at one of either the T1, E1 or J1 clock rates/modes. SEE "RECEIVE EQUALIZER CONTROL AND TRANSMIT LINE BUILD-OUT SETTINGS" ON PAGE 30. for description of Transmit Equalizer Control bits.</p> <p>Equalizer Control Input 3 Equalizer Control Input 2 Equalizer Control Input 1 Equalizer Control Input 0</p> <p>NOTES:</p> <ol style="list-style-type: none"> <i>In Hardware mode all transmit channels share the same pulse setting controls function.</i> <i>All channels of an XRT83L38 must operate at the same clock rate, either the T1, E1 or J1 modes.</i> <p>In Host mode, these pins perform various microprocessor functions. SEE "MICRO-PROCESSOR INTERFACE" ON PAGE 11.</p> <p>NOTE: Internally pulled "Low" with a 50kΩ resistor.</p>						
EQC3	B7	O I I I I I							
EQC2	A7								
EQC1	C7								
EQC0	D7								
$\overline{\text{RDY_DTACK}}$	A6								
$\overline{\text{CS}}$	B7								
$\overline{\text{ALE_AS}}$	A7								
$\overline{\text{RD_DS}}$	C7								
$\overline{\text{WR_RW}}$	D7								
RXTSEL	U11		I	<p>Receiver Termination Select</p> <p>In Hardware mode, when this pin is "Low" the receive line termination is determined only by an external resistor. When "High", the receive termination is realized by the internal resistor or the combination of internal and external resistors. These conditions are described in the table below.</p> <p>NOTE: In Hardware mode all channels share the same RXTSEL control function.</p> <table border="1" style="margin-left: auto; margin-right: auto;"> <thead> <tr> <th>RXTSEL</th> <th>RX Termination</th> </tr> </thead> <tbody> <tr> <td>0</td> <td>External</td> </tr> <tr> <td>1</td> <td>Internal</td> </tr> </tbody> </table> <p>In Host mode, the RXTSEL_n bits in the channel control registers determine if the receiver termination is external or internal. However, the function of RXTSEL can be transferred to the Hardware pin by setting the TERCNTL bit (bit 6) to "1" in the register address hex 0x82.</p> <p>NOTE: This pin is internally pulled "Low" with a 50kΩ resistor.</p>	RXTSEL	RX Termination	0	External	1
RXTSEL	RX Termination								
0	External								
1	Internal								
TXTSEL	V11	I	<p>Transmit Termination Select - Hardware Mode</p> <p>When this pin is "Low" the transmit line termination is determined only by an external resistor. When "High", the transmit termination is realized only by the internal resistor.</p> <table border="1" style="margin-left: auto; margin-right: auto;"> <thead> <tr> <th>TXTSEL</th> <th>TX Termination</th> </tr> </thead> <tbody> <tr> <td>0</td> <td>External</td> </tr> <tr> <td>1</td> <td>Internal</td> </tr> </tbody> </table> <p>NOTES:</p> <ol style="list-style-type: none"> <i>This pin is internally pulled "Low" with a 50kΩ resistor.</i> <i>In Hardware mode all channels share the same TXTSEL control function.</i> 	TXTSEL	TX Termination	0	External	1	Internal
TXTSEL	TX Termination								
0	External								
1	Internal								

SIGNAL NAME	LEAD #	TYPE	DESCRIPTION															
TERSEL1 TERSELO	T11 R11	I	<p>Termination Impedance Select bit 1: Termination Impedance Select bit 0:</p> <p>In the Hardware mode and in the internal termination mode (TXTSEL="1" and RXTSEL="1") TERSEL[1:0] control the transmit and receive termination impedance according to the following table.</p> <table border="1" style="margin-left: auto; margin-right: auto;"> <thead> <tr> <th>TERSEL1</th> <th>TERSELO</th> <th>Termination</th> </tr> </thead> <tbody> <tr> <td>0</td> <td>0</td> <td>100Ω</td> </tr> <tr> <td>0</td> <td>1</td> <td>110Ω</td> </tr> <tr> <td>1</td> <td>0</td> <td>75Ω</td> </tr> <tr> <td>1</td> <td>1</td> <td>120Ω</td> </tr> </tbody> </table> <p>In the internal termination mode the receiver termination of each receiver is realized completely by internal resistors or by the combination of internal and one fixed external resistor (see description of RXRES[1:0] pins).</p> <p>In the internal termination mode the transformer ratio of 1:2 or 1:2.45 and 1:1 is required for transmitter and receiver respectively with the transmitter output AC coupled to the transformer.</p> <p>NOTES:</p> <ol style="list-style-type: none"> 1. This pin is internally pulled "Low" with a 50kΩ resistor. 2. In Hardware mode, all channels share the same TERSEL control function. 3. In the external termination mode a 1:2 or 1:2.45 transformer ratio must be used for the transmitter. 	TERSEL1	TERSELO	Termination	0	0	100Ω	0	1	110Ω	1	0	75Ω	1	1	120Ω
TERSEL1	TERSELO	Termination																
0	0	100Ω																
0	1	110Ω																
1	0	75Ω																
1	1	120Ω																
TEST	U12	I	<p>Manufacturing Test:</p> <p>NOTE: For normal operation this pin must be tied to ground.</p>															
$\overline{\text{ICT}}$	V12	I	<p>In-Circuit Testing (Active "Low"):</p> <p>When this pin is tied "Low", all output pins are forced to a high impedance state for in-circuit testing.</p> <p>Pulling $\overline{\text{RESET}}$ and $\overline{\text{ICT}}$ pins "Low" simultaneously will put the chip in factory test mode. This condition should not be permitted during normal operation.</p> <p>NOTE: This pin is internally pulled "High" with a 50kΩ resistor.</p>															

POWER AND GROUND

SIGNAL NAME	LEAD #	TYPE	DESCRIPTION
TGND_0	D3	****	Transmitter Analog Ground for Channel _0
TGND_1	F2		Transmitter Analog Ground for Channel _1
TGND_2	E15		Transmitter Analog Ground for Channel _2
TGND_3	C17		Transmitter Analog Ground for Channel _3
TGND_4	R3		Transmitter Analog Ground for Channel _4
TGND_5	P3		Transmitter Analog Ground for Channel _5
TGND_6	T16		Transmitter Analog Ground for Channel _6
TGND_7	R16		Transmitter Analog Ground for Channel _7

SIGNAL NAME	LEAD #	TYPE	DESCRIPTION
TVDD_0	E4	****	Transmitter Analog Positive Supply (3.3V ± 5%) for Channel _0
TVDD_1	F4		Transmitter Analog Positive Supply (3.3V ± 5%) for Channel _1
TVDD_2	F16		Transmitter Analog Positive Supply (3.3V ± 5%) for Channel _2
TVDD_3	E17		Transmitter Analog Positive Supply (3.3V ± 5%) for Channel _3
TVDD_4	R4		Transmitter Analog Positive Supply (3.3V ± 5%) for Channel _4
TVDD_5	P1		Transmitter Analog Positive Supply (3.3V ± 5%) for Channel _5
TVDD_6	N15		Transmitter Analog Positive Supply (3.3V ± 5%) for Channel _6
TVDD_7	P15		Transmitter Analog Positive Supply (3.3V ± 5%) for Channel _7
RVDD_0	C2	****	Receiver Analog Positive Supply (3.3V± 5%) for Channel _0
RVDD_1	E5		Receiver Analog Positive Supply (3.3V± 5%) for Channel _1
RVDD_2	G16		Receiver Analog Positive Supply (3.3V± 5%) for Channel _2
RVDD_3	D16		Receiver Analog Positive Supply (3.3V± 5%) for Channel _3
RVDD_4	V2		Receiver Analog Positive Supply (3.3V± 5%) for Channel _4
RVDD_5	N3		Receiver Analog Positive Supply (3.3V± 5%) for Channel _5
RVDD_6	N17		Receiver Analog Positive Supply (3.3V± 5%) for Channel _6
RVDD_7	U18		Receiver Analog Positive Supply (3.3V± 5%) for Channel _7
RGND_0	D2	****	Receiver Analog Ground for Channel_0
RGND_1	G3		Receiver Analog Ground for Channel_1
RGND_2	G17		Receiver Analog Ground for Channel_2
RGND_3	D17		Receiver Analog Ground for Channel_3
RGND_4	T2		Receiver Analog Ground for Channel_4
RGND_5	M2		Receiver Analog Ground for Channel_5
RGND_6	M17		Receiver Analog Ground for Channel_6
RGND_7	R17		Receiver Analog Ground for Channel_7
AVDD Bias	K17	****	Analog Positive Supply (3.3V± 5%)
VDDPLL_1	J3		Analog Positive Supply for Master Clock Synthesizer PLL (3.3V± 5%)
VDDPLL_2	J2		Analog Positive Supply for Master Clock Synthesizer PLL (3.3V± 5%)
AGND Bias	J17	****	Analog Ground
GNDPLL_1	K3		Analog Ground for Master Clock Synthesizer PLL
GNDPLL_2	L4		Analog Ground for Master Clock Synthesizer PLL
DVDD_DRV	R9	****	Digital Positive Supply (3.3V± 5%)
DVDD_PRE	U10		Digital Positive Supply (3.3V± 5%)
DVDD_μP	K18		Digital Positive Supply (3.3V± 5%)
DVDD_PRE	D10		Digital Positive Supply (3.3V± 5%)
DVDD_DRV	K15		Digital Positive Supply (3.3V± 5%)
DVDD	A9		Digital Positive Supply (3.3V± 5%)
DGND_PRE	R8	****	Digital Ground
DGND_DRV	T9		Digital Ground
DGND_μP	H17		Digital Ground
DGND	B9		Digital Ground
DGND_DRV	D8		Digital Ground
DGND_PRE	C9		Digital Ground

PINS ONLY AVAILABLE IN BGA PACKAGE

SIGNAL NAME	LEAD #	TYPE	DESCRIPTION
DVDD_DRV	J4	****	Digital Positive Supply (3.3V± 5%)
DVDD_DRV	D9	****	Digital Positive Supply (3.3V± 5%)
DGND_DRV	G15	****	Digital Ground
DGND_DRV	K2	****	Digital Ground
RXON	K16	I	Receiver On - Hardware Mode Writing a "1" to this pin in Hardware mode turns on the Receive Sections of all channels. Writing a "0" shuts off the Receiver Sections of all channels.
NC1	A1	****	No Connect Pins
NC2	V1	****	
NC3	V18	****	
NC4	A18	****	
NC5	B1	****	
NC6	E1	****	
NC7	N1	****	
NC8	R1	****	
NC9	P18	****	
NC10	N18	****	
NC11	E18	****	
NC12	B18	****	

FUNCTIONAL DESCRIPTION

The XRT83L38 is a fully integrated long-haul and short-haul transceiver intended for T1, J1 or E1 systems. Simplified block diagrams of the chip are shown in **Figure 1, Host** mode and **Figure 2, Hardware** mode. The XRT83L38 can receive signals that have been attenuated from 0 to 36dB at 772kHz (0 to 6000 feet cable loss) for T1 and from 0 to 43dB at 1024kHz for E1 systems.

In T1 applications, the XRT83L38 can generate five transmit pulse shapes to meet the short-haul Digital Cross-connect (DSX-1) template requirement as well as four CSU Line Build-Out (LBO) filters of 0dB, -7.5dB, -15dB and -22.5dB as required by FCC rules. It also provides programmable transmit output pulse generators for each channel that can be used for output pulse shaping allowing performance improvement over a wide variety of conditions (The arbitrary pulse generators are available in both T1 and E1). The operation and configuration of the XRT83L38 can be controlled through a parallel microprocessor **Host** interface or **Hardware** control.

MASTER CLOCK GENERATOR

Using a variety of external clock sources, the on-chip frequency synthesizer generates the T1 (1.544MHz) or E1 (2.048MHz) master clocks necessary for the transmit pulse shaping and receive clock recovery circuit.

There are two master clock inputs MCLKE1 and MCLKT1. In systems where both T1 and E1 master clocks are available these clocks can be connected to the respective pins. All channels of a given XRT83L38 must be operated at the same clock rate, either T1, E1 or J1 modes.

In systems that have only one master clock source available (E1 or T1), that clock should be connected to both MCLKE1 and MCLKT1 inputs for proper operation. T1 or E1 master clocks can be generated from 8kHz, 16kHz, 56kHz, 64kHz, 128kHz and 256kHz external clocks under the control of CLKSEL[2:0] inputs according to **Table 1**.

NOTE: EQC[4:0] determine the T1/E1 operating mode. See **Table 5** for details.

FIGURE 4. TWO INPUT CLOCK SOURCE

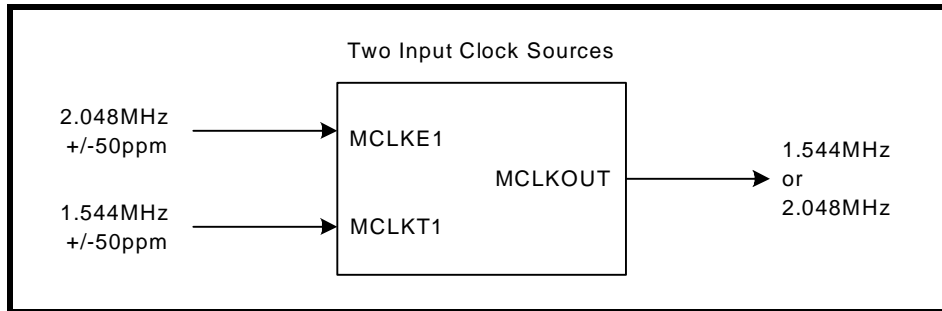

FIGURE 5. ONE INPUT CLOCK SOURCE

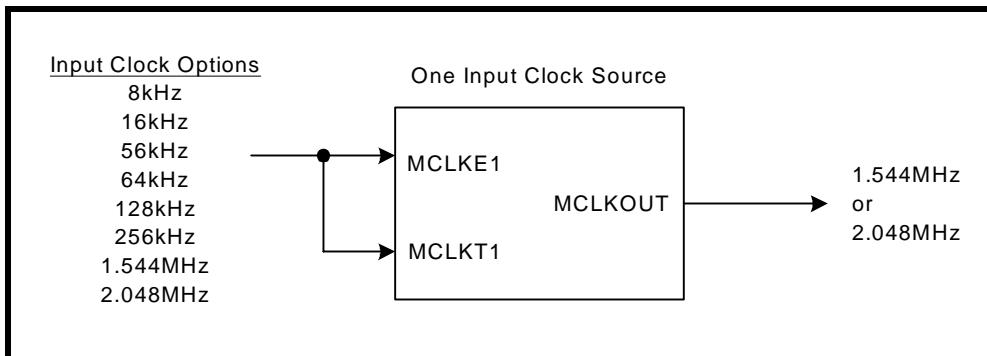

TABLE 1: MASTER CLOCK GENERATOR

MCLKE1 kHz	MCLKT1 kHz	CLKSEL2	CLKSEL1	CLKSEL0	MCLKRATE	MASTER CLOCK kHz
2048	2048	0	0	0	0	2048
2048	2048	0	0	0	1	1544
2048	1544	0	0	0	0	2048
1544	1544	0	0	1	1	1544
1544	1544	0	0	1	0	2048
2048	1544	0	0	1	1	1544
8	x	0	1	0	0	2048
8	x	0	1	0	1	1544
16	x	0	1	1	0	2048
16	x	0	1	1	1	1544
56	x	1	0	0	0	2048
56	x	1	0	0	1	1544
64	x	1	0	1	0	2048
64	x	1	0	1	1	1544
128	x	1	1	0	0	2048
128	x	1	1	0	1	1544
256	x	1	1	1	0	2048
256	x	1	1	1	1	1544

In **Host** mode the programming is achieved through the corresponding interface control bits, the state of the CLKSEL[2:0] control bits and the state of the MCLKRATE interface control bit.

RECEIVER

RECEIVER INPUT

At the receiver input, a cable attenuated AMI signal can be coupled to the receiver through a capacitor or a 1:1 transformer. The input signal is first applied to a selective equalizer for signal conditioning. The maximum equalizer gain is up to 36dB for T1 and 43dB for E1 modes. The equalized signal is subsequently applied to a peak detector which in turn controls the equalizer settings and the data slicer. The slicer threshold for both E1 and T1 is typically set at 50% of the peak amplitude at the equalizer output. After the slicers, the digital representation of the AMI signals are applied to the clock and data recovery circuit. The recovered data subsequently goes through the jitter attenuator and decoder (if selected) for HDB3 or B8ZS decoding before being applied to the RPOS_n/RDATA_n and RNEG_n/LCV_n pins. Clock recovery is accomplished by a digital phase-locked loop (DPLL) which does not require any external components and can tolerate high levels of input jitter that meets or exceeds the ITU-G.823 and TR-TSY000499 standards.

RECEIVE MONITOR MODE

In applications where Monitor mode is desired, the equalizer can be configured in a gain mode which handles input signals attenuated resistively up to 29dB, along with 0 to 6dB cable attenuation for both T1 and E1 applications, refer to **Table 5** for details. This feature is available in both **Hardware** and **Host** modes.

RECEIVER LOSS OF SIGNAL (RLOS)

For compatibility with ITU G.775 requirements, the RLOS monitoring function is implemented using both analog and digital detection schemes. If the analog RLOS condition occurs, a digital detector is activated to count for 32 consecutive zeros in E1 (4096 bits in Extended Los mode, EXLOS = "1") or 175 consecutive zeros in T1 before RLOS is asserted. RLOS is cleared when the input signal rises +3dB (built in hysteresis) above the point at which it was declared and meets 12.5% ones density of 4 ones in a 32 bit window, with no more than 16 consecutive zeros for E1. In T1 mode, RLOS is cleared when the input signal rises +3dB (built in hysteresis) above the point at which it was declared and contains 16 ones in a 128 bit window with no more than 100 consecutive zeros in the data stream. When loss of signal occurs, RLOS register indication and register status will change. If the RLOS register enable is set high (enabled), the alarm will trigger an interrupt causing the interrupt pin (INT) to go low. Once the alarm status register has been read, it will automatically reset upon read (RUR), and the INT pin will return high.

Analog RLOS

Setting the Receiver Inputs to -15dB T1/E1 Short Haul Mode

By setting the receiver inputs to -15dB T1/E1 short haul mode, the equalizer will detect the incoming amplitude and make adjustments by adding gain up to a maximum of +15dB normalizing the T1/E1 input signal.

NOTE: This is the only setting that refers to cable loss (frequency), not flat loss (resistive).

Once the T1/E1 input signal has been normalized to 0dB by adding the maximum gain (+15dB), the receiver will declare RLOS if the signal is attenuated by an additional -9dB. The total cable loss at RLOS declaration is typically -24dB (-15dB + -9dB). A 3dB hysteresis was designed so that transients will not trigger the RLOS to clear. Therefore, the RLOS will typically clear at a total cable attenuation of -21dB. See **Figure 6** for a simplified diagram.

FIGURE 6. SIMPLIFIED DIAGRAM OF -15dB T1/E1 SHORT HAUL MODE AND RLOS CONDITION

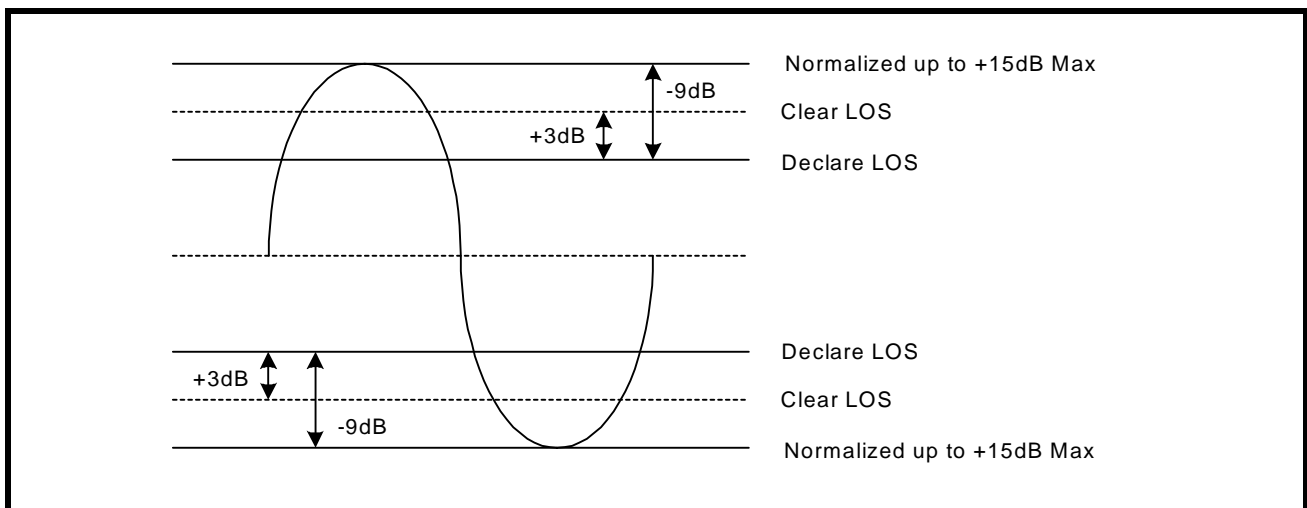

Setting the Receiver Inputs to -29dB T1/E1 Gain Mode

By setting the receiver inputs to -29dB T1/E1 gain mode, the equalizer will detect the incoming amplitude and make adjustments by adding gain up to a maximum of +29dB normalizing the T1/E1 input signal.

NOTE: This is the only setting that refers to flat loss (resistive). All other modes refer to cable loss (frequency).

OCTAL T1/E1/J1 LH/SH TRANSCEIVER WITH CLOCK RECOVERY AND JITTER ATTENUATOR

Once the T1/E1 input signal has been normalized to 0dB by adding the maximum gain (+29dB), the receiver will declare RLOS if the signal is attenuated by an additional -9dB. The total cable loss at RLOS declaration is typically -38dB (-29dB + -9dB). A 3dB hysteresis was designed so that transients will not trigger the RLOS to clear. Therefore, the RLOS will typically clear at a total flat loss of -35dB. See **Figure 7** for a simplified diagram.

FIGURE 7. SIMPLIFIED DIAGRAM OF -29dB T1/E1 GAIN MODE AND RLOS CONDITION

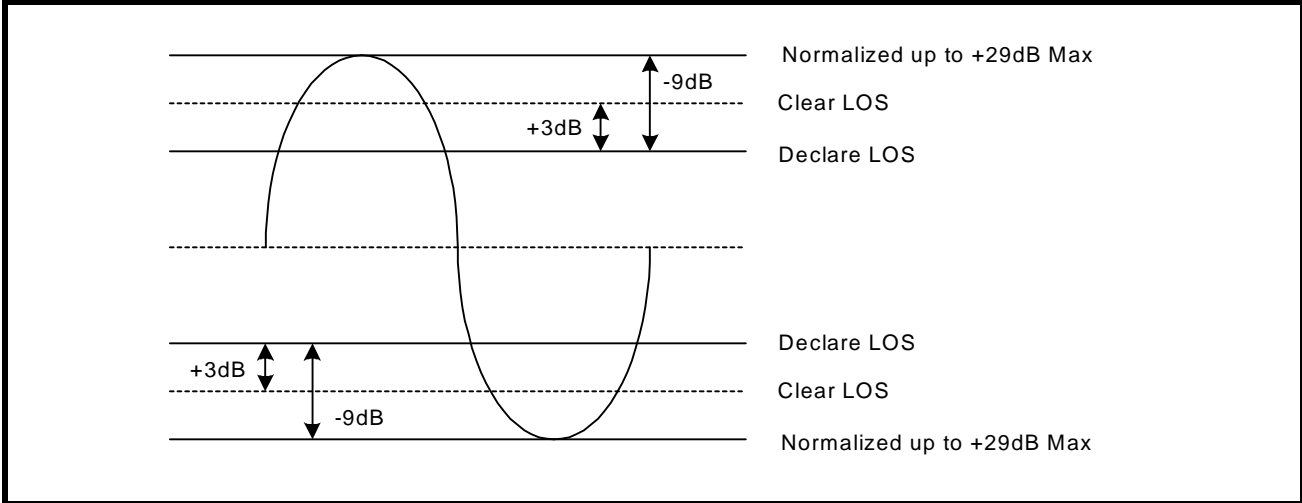

Setting the Receiver Inputs to -36dB T1/E1 Long Haul Mode

By setting the receiver inputs to -36dB T1/E1 long haul mode, the equalizer will detect the incoming amplitude and make adjustments by adding gain up to a maximum of +36dB normalizing the T1 input signal. This setting refers to cable loss (frequency), not flat loss (resistive). Once the T1/E1 input signal has been normalized to 0dB by adding the maximum gain (+36dB), the receiver will declare RLOS if the signal is attenuated by an additional -9dB. The total cable loss at RLOS declaration is typically -45dB (-36dB + -9dB). A 3dB hysteresis was designed so that transients will not trigger the RLOS to clear. Therefore, the RLOS will typically clear at a total cable attenuation of -42dB. See **Figure 8** for a simplified diagram.

FIGURE 8. SIMPLIFIED DIAGRAM OF -36dB T1/E1 LONG HAUL MODE AND RLOS CONDITION

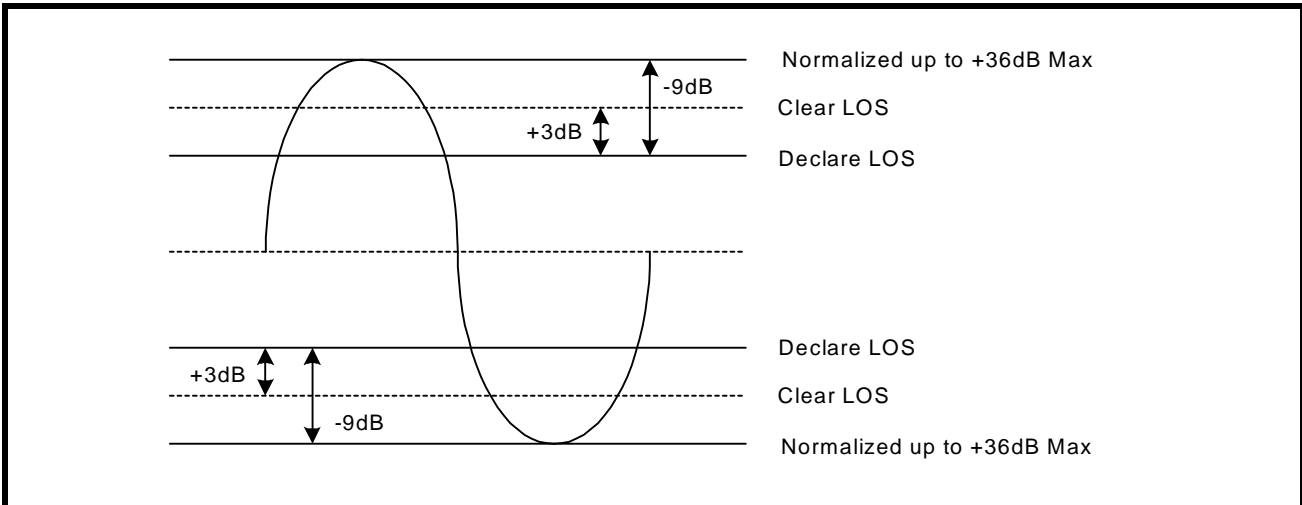

E1 Extended RLOS

E1: Setting the Receiver Inputs to Extended RLOS

By setting the receiver inputs to extended RLOS, the equalizer will detect the incoming amplitude and make adjustments by adding gain up to a maximum of +43dB normalizing the E1 input signal. This setting refers to

cable loss (frequency), not flat loss (resistive). Once the E1 input signal has been normalized to 0dB by adding the maximum gain (+43dB), the receiver will declare RLOS if the signal is attenuated by an additional -9dB. The total cable loss at RLOS declaration is typically -52dB (-43dB + -9dB). A 3dB hysteresis was designed so that transients will not trigger the RLOS to clear. Therefore, the RLOS will typically clear at a total cable attenuation of -49dB. See **Figure 9** for a simplified diagram.

FIGURE 9. SIMPLIFIED DIAGRAM OF EXTENDED RLOS MODE (E1 ONLY)

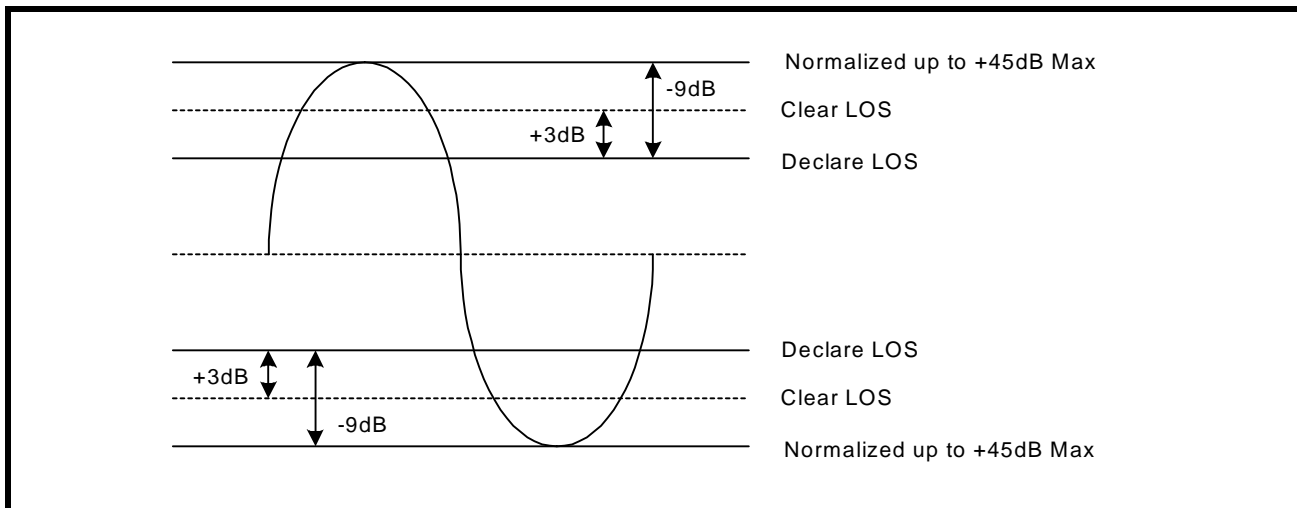

RECEIVE HDB3/B8ZS DECODER

The Decoder function is available in both **Hardware** and **Host** modes on a per channel basis by controlling the TNEG_n/CODES_n pin or the CODES_n interface bit. The decoder function is only active in single-rail Mode. When selected, receive data in this mode will be decoded according to HDB3 rules for E1 and B8ZS for T1 systems. Bipolar violations that do not conform to the coding scheme will be reported as Line Code Violation at the RNEG_n/LCV_n pin of each channel. The length of the LCV pulse is one RCLK cycle for each code violation. In E1 mode only, an excessive number of zeros in the receive data stream is also reported as an error at the same output pin. If AMI decoding is selected in single rail mode, every bipolar violation in the receive data stream will be reported as an error at the RNEG_n/LCV_n pin.

RECOVERED CLOCK (RCLK) SAMPLING EDGE

This feature is available in both **Hardware** and **Host** modes on a global basis. In **Host** mode, the sampling edge of RCLK output can be changed through the interface control bit RCLKE. If a “1” is written in the RCLKE interface bit, receive data output at RPOS_n/RDATA_n and RNEG_n/LCV_n are updated on the falling edge of

RCLK for all eight channels. Writing a “0” to the RCLKE register, updates the receive data on the rising edge of RCLK. In **Hardware** mode the same feature is available under the control of the RCLKE pin.

FIGURE 10. RECEIVE CLOCK AND OUTPUT DATA TIMING

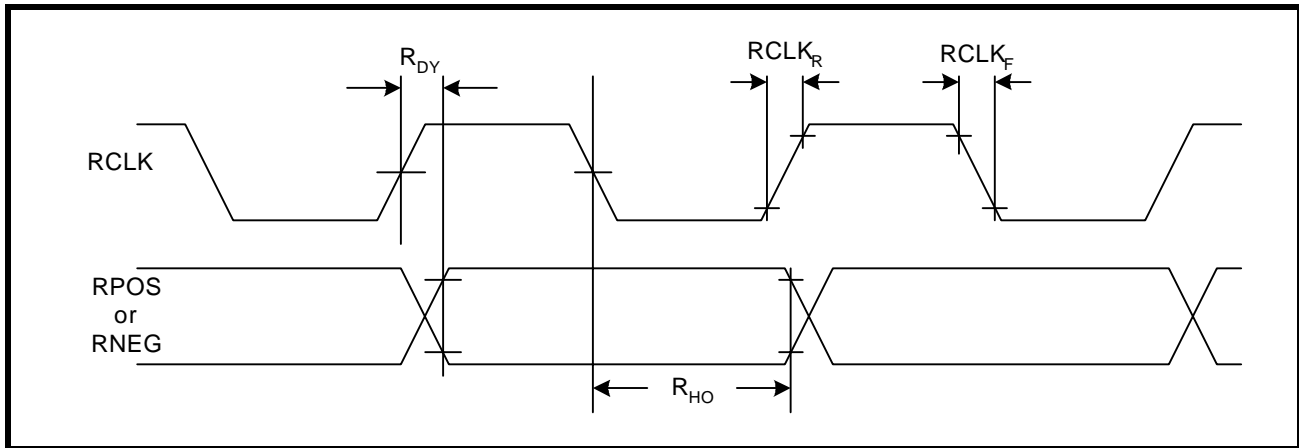

JITTER ATTENUATOR

To reduce phase and frequency jitter in the recovered clock, the jitter attenuator can be placed in the receive signal path. The jitter attenuator uses a data FIFO (First In First Out) with a programmable depth that can vary between 2x32 and 2x64. The jitter attenuator can also be placed in the transmit signal path or disabled altogether depending upon system requirements. The jitter attenuator, other than using the master clock as reference, requires no external components. With the jitter attenuator selected, the typical throughput delay from input to output is 16 bits for 32 bit FIFO size or 32 bits for 64 bit FIFO size. When the read and write pointers of the FIFO in the jitter attenuator are within two bits of over-flowing or under-flowing, the bandwidth of the jitter attenuator is widened to track the short term input jitter, thereby avoiding data corruption. When this situation occurs, the jitter attenuator will not attenuate input jitter until the read/write pointer's position is outside the two bits window. Under normal condition, the jitter transfer characteristic meets the narrow bandwidth requirement as specified in ITU- G.736, ITU- I.431 and AT&T Pub 62411 standards.

In T1 mode the Jitter Attenuator Bandwidth is always set to 3Hz. In E1 mode, the bandwidth can be reduced through the JABW control signal. When JABW is set “High” the bandwidth of the jitter attenuator is reduced from 10Hz to 1.5Hz. Under this condition the FIFO length is automatically set to 64 bits and the 32 bits FIFO length will not be available in this mode. Jitter attenuator controls are available on a per channel basis in the **Host** mode and on a global basis in the **Hardware** mode.

GAPPED CLOCK (JA MUST BE ENABLED IN THE TRANSMIT PATH)

The XRT83L38 LIU is ideal for multiplexer or mapper applications where the network data crosses multiple timing domains. As the higher data rates are de-multiplexed down to T1 or E1 data, stuffing bits are removed which can leave gaps in the incoming data stream. If the jitter attenuator is enabled in the transmit path, the 32-Bit or 64-Bit FIFO is used to smooth the gapped clock into a steady T1 or E1 output. The maximum gap width of the 8-Channel LIU is shown in **Table 2**.

TABLE 2: MAXIMUM GAP WIDTH FOR MULTIPLEXER/MAPPER APPLICATIONS

FIFO DEPTH	MAXIMUM GAP WIDTH
32-Bit	20 UI
64-Bit	50 UI

NOTE: If the LIU is used in a loop timing system, the jitter attenuator should be enabled in the receive path.

ARBITRARY PULSE GENERATOR FOR T1 AND E1

The arbitrary pulse generator divides the pulse into eight individual segments. Each segment is set by a 7-Bit binary word by programming the appropriate channel register. This allows the system designer to set the overshoot, amplitude, and undershoot for a unique line build out. The MSB (bit 7) is a sign-bit. If the sign-bit is set to “1”, the segment will move in a positive direction relative to a flat line (zero) condition. If this sign-bit is set to “0”, the segment will move in a negative direction relative to a flat line condition. A pulse with numbered segments is shown in **Figure 11**.

FIGURE 11. ARBITRARY PULSE SEGMENT ASSIGNMENT

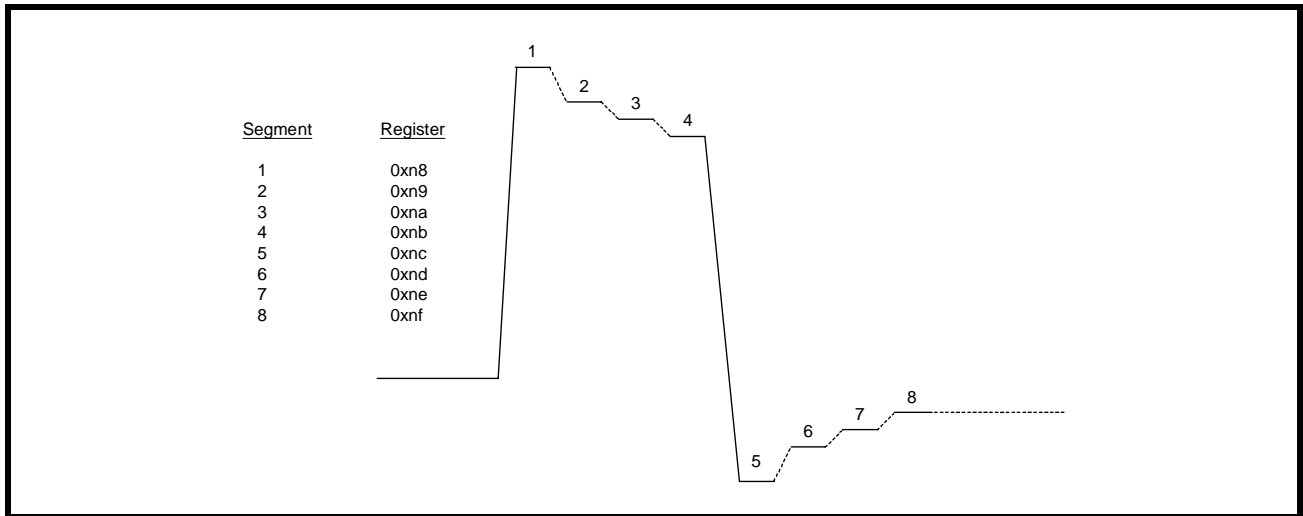

NOTE: By default, the arbitrary segments are programmed to 0x00h. The transmitter outputs will result in an all zero pattern to the line. For E1 arbitrary mode, see global register 0xC0h.

TRANSMITTER

DIGITAL DATA FORMAT

Both the transmitter and receiver can be configured to operate in dual or single-rail data formats. This feature is available under both **Hardware** and **Host** control modes, on a global basis. The dual or single-rail data format is determined by the state of the SR/DR pin in **Hardware** mode or SR/DR interface bit in the **Host** mode. In single-rail mode, transmit clock and NRZ data are applied to TCLK_n and TPOS_n/TDATA_n pins respectively. In single-rail and **Hardware** mode the TNEG_n/CODES_n input can be used as the CODES function. With TNEG_n/CODES_n tied “Low”, HDB3 or B8ZS encoding and decoding are enabled for E1 and T1 modes respectively. With TNEG_n/CODES_n tied “High”, the AMI coding scheme is selected. In both dual or single-rail modes of operations, the transmitter converts digital input data to a bipolar format before being transmitted to the line.

TRANSMIT CLOCK (TCLK) SAMPLING EDGE

Serial transmit data at TPOS_n/TDATA_n and TNEG_n/CODES_n are clocked into the XRT83L38 under the synchronization of TCLK_n. With a “0” written to the TCLKE interface bit, or by pulling the TCLKE pin “Low”, input data is sampled on the falling edge of TCLK_n. The sampling edge is inverted with a “1” written to TCLKE interface bit, or by connecting the TCLKE pin “High”.

FIGURE 12. TRANSMIT CLOCK AND INPUT DATA TIMING

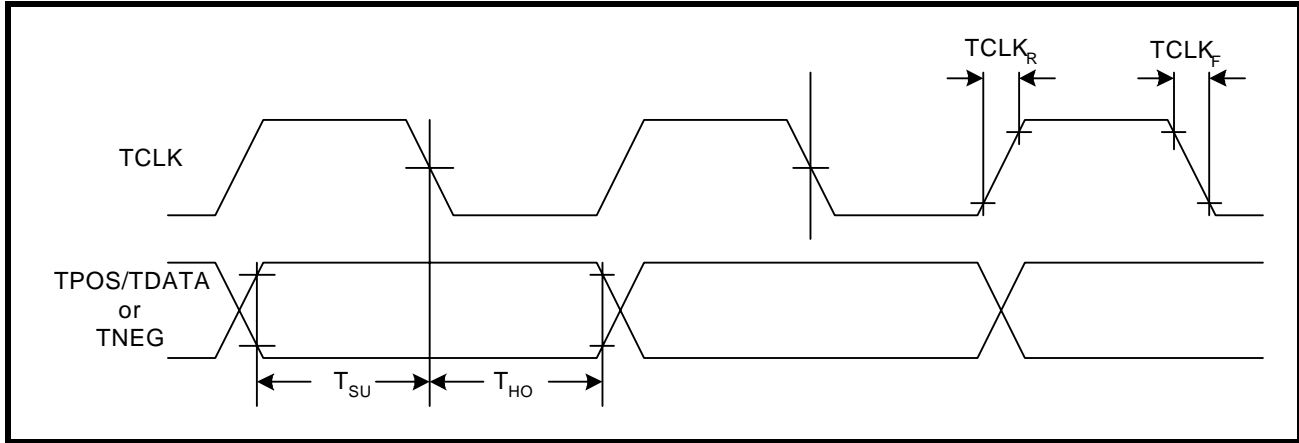

TRANSMIT HDB3/B8ZS ENCODER

The Encoder function is available in both **Hardware** and **Host** modes on a per channel basis by controlling the TNEG_n/CODES_n pin or CODES interface bit. The encoder is only available in single-rail mode. In E1 mode and with HDB3 encoding selected, any sequence with four or more consecutive zeros in the input serial data from TPOS_n/TDATA_n, will be removed and replaced with 000V or B00V, where “B” indicates a pulse conforming with the bipolar rule and “V” representing a pulse violating the rule. An example of HDB3 Encoding is shown in **Table 3**. In a T1 system, an input data sequence with eight or more consecutive zeros will be removed and replaced using the B8ZS encoding rule. An example of Bipolar with 8 Zero Substitution (B8ZS) encoding scheme is shown in **Table 4**. Writing a “1” into the CODES_n interface bit or connecting the TNEG_n/CODES_n pin to a “High” level selects the AMI coding for both E1 or T1 systems.

TABLE 3: EXAMPLES OF HDB3 ENCODING

	NUMBER OF PULSE BEFORE NEXT 4 ZEROS	NEXT 4 BITS
Input		0000
HDB3 (case1)	odd	000V
HDB3 (case2)	even	B00V

TABLE 4: EXAMPLES OF B8ZS ENCODING

CASE 1	PRECEDING PULSE	NEXT 8 BITS
Input	+	00000000
B8ZS		000VB0VB
AMI Output	+	000+ -0- +
CASE 2		
Input	-	00000000
B8ZS		000VB0VB
AMI Output	-	000- +0+ -

DRIVER FAILURE MONITOR (DMO)

The driver monitor circuit is used to detect transmit driver failure by monitoring the activities at TTIP and TRING outputs. Driver failure may be caused by a short circuit in the primary transformer or system problems at the transmit input. If the transmitter of a channel has no output for more than 128 clock cycles, the corresponding DMO pin goes “High” and remains “High” until a valid transmit pulse is detected. In **Host** mode, the failure of the transmit channel is reported in the corresponding interface bit. If the DMOIE bit is also enabled, any transition on the DMO interface bit will generate an interrupt. The driver failure monitor is supported in both **Hardware** and **Host** modes on a per channel basis.

TRANSMIT PULSE SHAPER & LINE BUILD OUT (LBO) CIRCUIT

The transmit pulse shaper circuit uses the high speed clock from the Master timing generator to control the shape and width of the transmitted pulse. The internal high-speed timing generator eliminates the need for a tightly controlled transmit clock (TCLK) duty cycle. With the jitter attenuator not in the transmit path, the transmit output will generate no more than 0.025Unit Interval (UI) peak-to-peak jitter. In **Hardware** mode, the state of the A[4:0]/EQC[4:0] pins determine the transmit pulse shape for all eight channels. In **Host** mode transmit pulse shape can be controlled on a per channel basis using the interface bits EQC[4:0]. The chip supports five fixed transmit pulse settings for T1 Short-haul applications plus a fully programmable waveform generator for arbitrary transmit output pulse shapes (The arbitrary pulse generators are available for both T1 and E1). Transmit Line Build-Outs for T1 long-haul application are supported from 0dB to -22.5dB in three 7.5dB steps. The choice of the transmit pulse shape and LBO under the control of the interface bits are summarized in **Table 5**. For CSU LBO transmit pulse design information, refer to ANSI T1.403-1993 Network-to-Customer Installation specification, Annex-E.

NOTE: EQC[4:0] determine the T1/E1 operating mode of the XRT83L38. When EQC4 = “1” and EQC3 = “1”, the XRT83L38 is in the E1 mode, otherwise it is in the T1/J1 mode. For details on how to enable the E1 arbitrary mode, see global register 0xC0h.

TABLE 5: RECEIVE EQUALIZER CONTROL AND TRANSMIT LINE BUILD-OUT SETTINGS

EQC4	EQC3	EQC2	EQC1	EQC0	E1/T1 MODE & RECEIVE SENSITIVITY	TRANSMIT LBO	CABLE	CODING
0	0	0	0	0	T1 Long Haul/36dB	0dB	100Ω/ TP	B8ZS
0	0	0	0	1	T1 Long Haul/36dB	-7.5dB	100Ω/ TP	B8ZS
0	0	0	1	0	T1 Long Haul/36dB	-15dB	100Ω/ TP	B8ZS
0	0	0	1	1	T1 Long Haul/36dB	-22.5dB	100Ω/ TP	B8ZS
0	0	1	0	0	T1 Long Haul/45dB	0dB	100Ω/ TP	B8ZS
0	0	1	0	1	T1 Long Haul/45dB	-7.5dB	100Ω/ TP	B8ZS
0	0	1	1	0	T1 Long Haul/45dB	-15dB	100Ω/ TP	B8ZS
0	0	1	1	1	T1 Long Haul/45dB	-22.5dB	100Ω/ TP	B8ZS
0	1	0	0	0	T1 Short Haul/15dB	0-133 ft./ 0.6dB	100Ω/ TP	B8ZS
0	1	0	0	1	T1 Short Haul/15dB	133-266 ft./ 1.2dB	100Ω/ TP	B8ZS
0	1	0	1	0	T1 Short Haul/15dB	266-399 ft./ 1.8dB	100Ω/ TP	B8ZS
0	1	0	1	1	T1 Short Haul/15dB	399-533 ft./ 2.4dB	100Ω/ TP	B8ZS
0	1	1	0	0	T1 Short Haul/15dB	533-655 ft./ 3.0dB	100Ω/ TP	B8ZS
0	1	1	0	1	T1 Short Haul/15dB	Arbitrary Pulse	100Ω/ TP	B8ZS

TABLE 5: RECEIVE EQUALIZER CONTROL AND TRANSMIT LINE BUILD-OUT SETTINGS

EQC4	EQC3	EQC2	EQC1	EQC0	E1/T1 MODE & RECEIVE SENSITIVITY	TRANSMIT LBO	CABLE	CODING
0	1	1	1	0	T1 Gain Mode/29dB	0-133 ft./ 0.6dB	100Ω/ TP	B8ZS
0	1	1	1	1	T1 Gain Mode/29dB	133-266 ft./ 1.2dB	100Ω/ TP	B8ZS
1	0	0	0	0	T1 Gain Mode/29dB	266-399 ft./ 1.8dB	100Ω/ TP	B8ZS
1	0	0	0	1	T1 Gain Mode/29dB	399-533 ft./ 2.4dB	100Ω/ TP	B8ZS
1	0	0	1	0	T1 Gain Mode/29dB	533-655 ft./ 3.0dB	100Ω/ TP	B8ZS
1	0	0	1	1	T1 Gain Mode/29dB	Arbitrary Pulse	100Ω/ TP	B8ZS
1	0	1	0	0	T1 Gain Mode/29dB	0dB	100Ω/ TP	B8ZS
1	0	1	0	1	T1 Gain Mode/29dB	-7.5dB	100Ω/ TP	B8ZS
1	0	1	1	0	T1 Gain Mode/29dB	-15dB	100Ω/ TP	B8ZS
1	0	1	1	1	T1 Gain Mode/29dB	-22.5dB	100Ω/ TP	B8ZS
1	1	0	0	0	E1 Long Haul/36dB	ITU G.703/Arbitrary	75Ω Coax	HDB3
1	1	0	0	1	E1 Long Haul/36dB	ITU G.703/Arbitrary	120Ω TP	HDB3
1	1	0	1	0	E1 Long Haul/43dB	ITU G.703/Arbitrary	75Ω Coax	HDB3
1	1	0	1	1	E1 Long Haul/43dB	ITU G.703/Arbitrary	120Ω TP	HDB3
1	1	1	0	0	E1 Short Haul	ITU G.703/Arbitrary	75Ω Coax	HDB3
1	1	1	0	1	E1 Short Haul	ITU G.703/Arbitrary	120Ω TP	HDB3
1	1	1	1	0	E1 Gain Mode	ITU G.703/Arbitrary	75Ω Coax	HDB3
1	1	1	1	1	E1 Gain Mode	ITU G.703/Arbitrary	120Ω TP	HDB3

TRANSMIT AND RECEIVE TERMINATIONS

The XRT83L38 is a versatile LIU that can be programmed to use one Bill of Materials (BOM) for worldwide applications for T1, J1 and E1. For specific applications the internal terminations can be disabled to allow the use of existing components and/or designs.

RECEIVER (CHANNELS 0 - 7)

INTERNAL RECEIVE TERMINATION MODE

In **Hardware** mode, RXTSEL (Pin 83) can be tied “High” to select internal termination mode for all receive channels or tied “Low” to select external termination mode. Individual channel control can only be done in **Host** mode. By default the XRT83L38 is set for external termination mode at power up or at **Hardware** reset.

TABLE 6: RECEIVE TERMINATION CONTROL

RXTSEL	RX TERMINATION
0	EXTERNAL
1	INTERNAL

In **Host** mode, bit 7 in the appropriate channel register, (Table 20, “Microprocessor Register #1, Bit Description,” on page 51), is set “High” to select the internal termination mode for that specific receive channel.

FIGURE 13. SIMPLIFIED DIAGRAM FOR THE INTERNAL RECEIVE AND TRANSMIT TERMINATION MODE

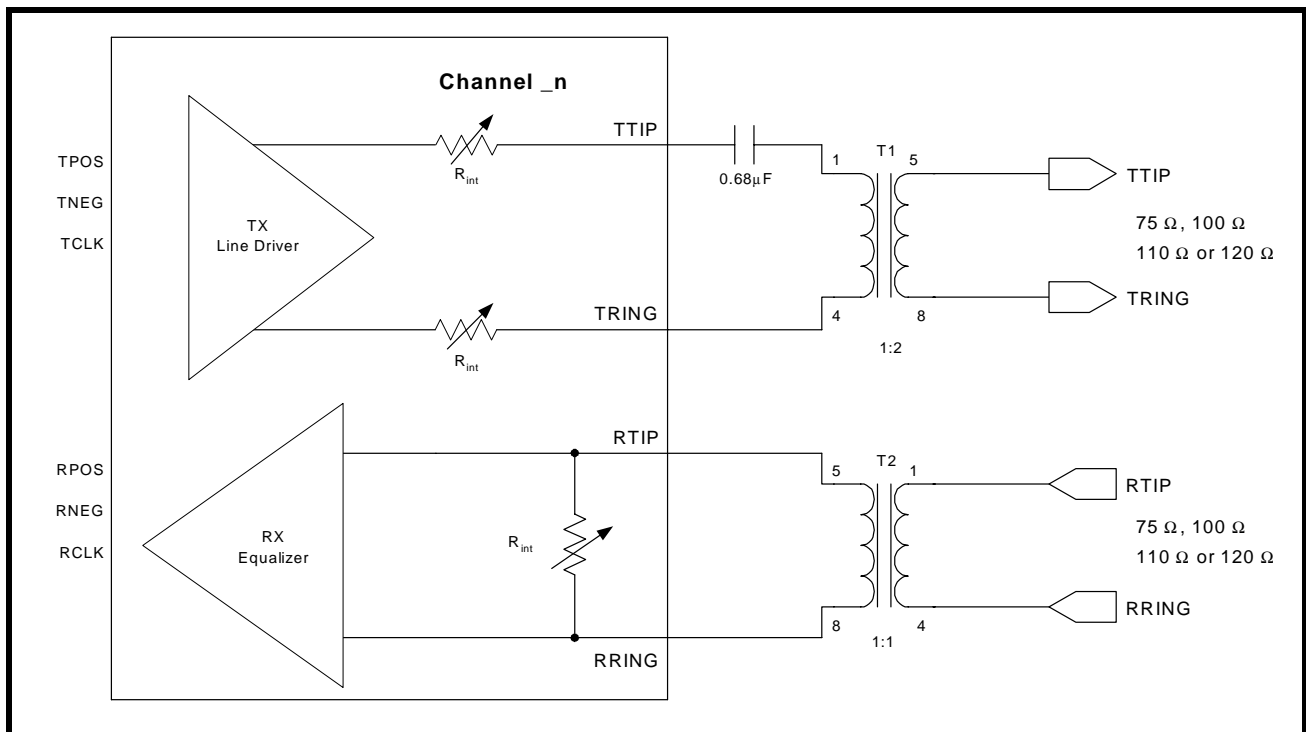

If the internal termination mode (RXTSEL = “1”) is selected, the effective impedance for E1, T1 or J1 can be achieved either with an internal resistor or a combination of internal and external resistors as shown in Table 7.

NOTE: In **Hardware** mode, pins RXRES[1:0] control all channels.

TABLE 7: RECEIVE TERMINATIONS

RXTSEL	TERSEL1	TERSEL0	RXRES1	RXRES0	R _{ext}	R _{int}	MODE
0	x	x	x	x	R _{ext}	∞	T1/E1/J1
1	0	0	0	0	∞	100Ω	T1
1	0	1	0	0	∞	110Ω	J1
1	1	0	0	0	∞	75Ω	E1

TABLE 7: RECEIVE TERMINATIONS

RXTSEL	TERSEL1	TERSEL0	RXRES1	RXRES0	R _{ext}	R _{int}	MODE
1	1	1	0	0	∞	120Ω	E1
1	0	0	0	1	240Ω	172Ω	T1
1	0	1	0	1	240Ω	204Ω	J1
1	1	0	0	1	240Ω	108Ω	E1
1	1	1	0	1	240Ω	240Ω	E1
1	0	0	1	0	210Ω	192Ω	T1
1	0	1	1	0	210Ω	232Ω	J1
1	1	0	1	0	210Ω	116Ω	E1
1	1	1	1	0	210Ω	280Ω	E1
1	0	0	1	1	150Ω	300Ω	T1
1	0	1	1	1	150Ω	412Ω	J1
1	1	0	1	1	150Ω	150Ω	E1
1	1	1	1	1	150Ω	600Ω	E1

Figure 14 is a simplified diagram for T1 (100Ω) in the external receive and transmit termination mode. Figure 15 is a simplified diagram for E1 (75Ω) in the external receive and transmit termination mode.

FIGURE 14. SIMPLIFIED DIAGRAM FOR T1 IN THE EXTERNAL TERMINATION MODE (RXTSEL= 0)

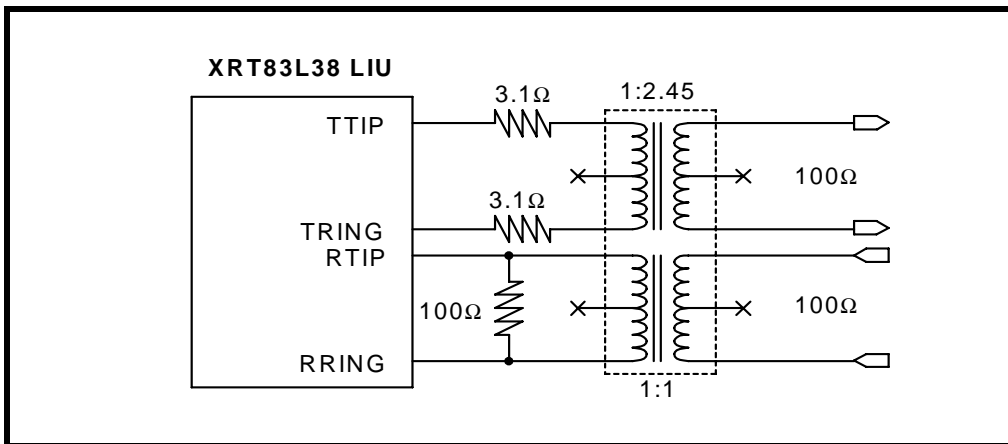
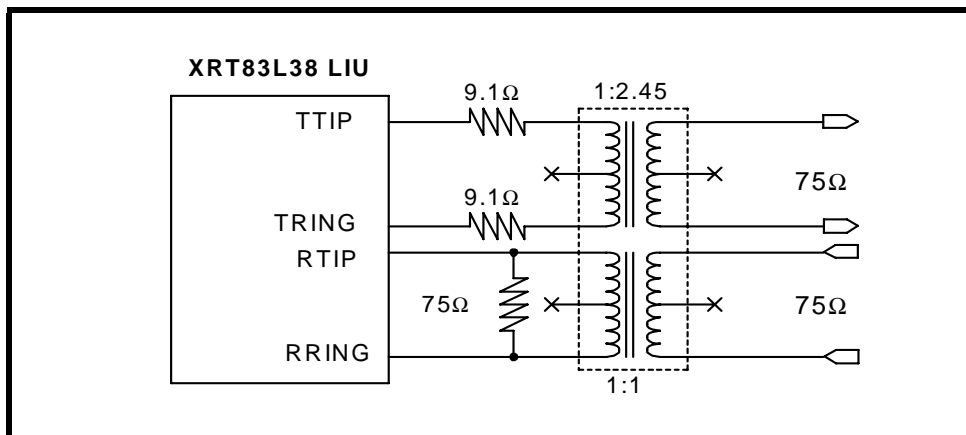

FIGURE 15. SIMPLIFIED DIAGRAM FOR E1 IN EXTERNAL TERMINATION MODE (RXTSEL= 0)



TRANSMITTER (CHANNELS 0 - 7)

TRANSMIT TERMINATION MODE

In **Hardware** mode, TXTSEL (Pin 84) can be tied “High” to select internal termination mode for all transmit channels or tied “Low” for external termination. Individual channel control can be done only in **Host** mode. In **Host** mode, bit 6 in the appropriate register for a given channel is set “High” to select the internal termination mode for that specific transmit channel, see **Table 20, “Microprocessor Register #1, Bit Description,”** on page 51.

TABLE 8: TRANSMIT TERMINATION CONTROL

TXTSEL	TX TERMINATION	Tx TRANSFORMER RATIO
0	EXTERNAL	1:2.45
1	INTERNAL	1:2

In internal mode, no external resistors are used. An external capacitor of 0.68μF is used for proper operation of the internal termination circuitry, see **Figure 13**.

TABLE 9: TERMINATION SELECT CONTROL

TERSEL1	TERSEL0	TERMINATION
0	0	100Ω
0	1	110Ω
1	0	75Ω
1	1	120Ω

EXTERNAL TRANSMIT TERMINATION MODE

By default the XRT83L38 is set for external termination mode at power up or at **Hardware** reset.

When external transmit termination mode is selected, the internal termination circuitry is disabled. The value of the external resistors is chosen for a specific application according to the turns ratio selected by TRATIO (Pin 127) in **Hardware** mode or bit 0 in the appropriate register for a specific channel in **Host** mode, see **Table 10** and **Table 22, “Microprocessor Register #3, Bit Description,”** on page 55. **Figure 14** is a simplified block diagram for T1 (100Ω) in the external termination mode. **Figure 15** is a simplified block diagram for E1 (75Ω) in the external termination mode.

TABLE 10: TRANSMIT TERMINATION CONTROL

TRATIO	TURNS RATIO
0	1:2.45
1	1:2

Table 11 summarizes the transmit terminations.

TABLE 11: TRANSMIT TERMINATIONS

	TERSEL1	TERSEL0	TXTSEL	TRATIO	$R_{int} \Omega$	n	$R_{ext} \Omega$	C_{ext}
			0=EXTERNAL 1=INTERNAL		SET BY CONTROL BITS	n, R_{ext} , AND C_{ext} ARE SUGGESTED SETTINGS		
T1 100 Ω	0	0	0	0	0 Ω	2.45	3.1 Ω	0
	0	0	0	1	0 Ω	2	3.1 Ω	0
	0	0	1	x	12.5 Ω	2	0 Ω	0.68 μ F
J1 110 Ω	0	1	0	0	0 Ω	2.45	3.1 Ω	0
	0	1	0	1	0 Ω	2	3.1 Ω	0
	0	1	1	x	13.75 Ω	2	0 Ω	0.68 μ F
E1 75 Ω	1	0	0	0	0 Ω	2.45	6.2 Ω	0
	1	0	0	1	0 Ω	2	9.1 Ω	0
	1	0	1	x	9.4 Ω	2	0 Ω	0.68 μ F
E1 120 Ω	1	1	0	0	0 Ω	2.45	6.2 Ω	0
	1	1	0	1	0 Ω	2	9.1 Ω	0
	1	1	1	x	15 Ω	2	0 Ω	0.68 μ F

REDUNDANCY APPLICATIONS

Telecommunication system design requires signal integrity and reliability. When a T1/E1 primary line card has a failure, it must be swapped with a backup line card while maintaining connectivity to a backplane without losing data. System designers can achieve this by implementing common redundancy schemes with the XRT83L38 Line Interface Unit (LIU). The XRT83L38 offers features that are tailored to redundancy applications while reducing the number of components and providing system designers with solid reference designs. These features allow system designers to implement redundancy applications that ensure reliability. The Internal Impedance mode eliminates the need for external relays when using the 1:1 and 1+1 redundancy schemes.

PROGRAMMING CONSIDERATIONS

In many applications switching the control of the transmitter outputs and the receiver line impedance to **hardware** control will provide faster transmitter ON/OFF switching.

In **Host Mode**, there are two bits in register 130 (82H) that control the transmitter outputs and the Rx line impedance select, TXONCNTL (Bit 7) and TERCNTL (Bit 6).

Setting bit-7 (TXONCNTL) to a “1” transfers the control of the Transmit On/Off function to the TXON_n **Hardware** control pins. (Pins 90 through 93 and pins 169 through 172).

Setting bit-6 (TERCNTL) to a “1” transfers the control of the Rx line impedance select (RXTSEL) to the RXTSEL **Hardware** control pin (pin 83).

Either mode works well with redundancy applications. The user can determine which mode has the fastest switching time for a unique application.

TYPICAL REDUNDANCY SCHEMES

- ·1:1 One backup card for every primary card (Facility Protection)
- ·1+1 One backup card for every primary card (Line Protection)
- ·N+1 One backup card for N primary cards

1:1 REDUNDANCY

A 1:1 facility protection redundancy scheme has one backup card for every primary card. When using 1:1 redundancy, the backup card has its transmitters tri-stated and its receivers in high impedance. This eliminates the need for external relays and provides one bill of materials for all interface modes of operation. The transmit and receive sections of the LIU device are described separately.

1+1 REDUNDANCY

A 1+1 line protection redundancy scheme has one backup card for every primary card, and the receivers on the backup card are monitoring the receiver inputs. Therefore, the receivers on both cards need to be active. The transmit outputs require no external resistors. The transmit and receive sections of the LIU device are described separately.

TRANSMIT 1:1 & 1+1 REDUNDANCY

For 1:1 and 1+1 redundancy, the transmitters on the primary and backup card should be programmed for Internal Impedance mode. The transmitters on the backup card should be tri-stated. Select the appropriate impedance for the desired mode of operation, T1/E1/J1. A 0.68uF capacitor is used in series with TTIP for blocking DC bias. See **Figure 16** for a simplified block diagram of the transmit section for 1:1 and 1+1 redundancy scheme.

NOTE: For simplification, the over voltage protection circuitry was omitted.

FIGURE 16. SIMPLIFIED BLOCK DIAGRAM OF THE TRANSMIT SECTION FOR 1:1 & 1+1 REDUNDANCY

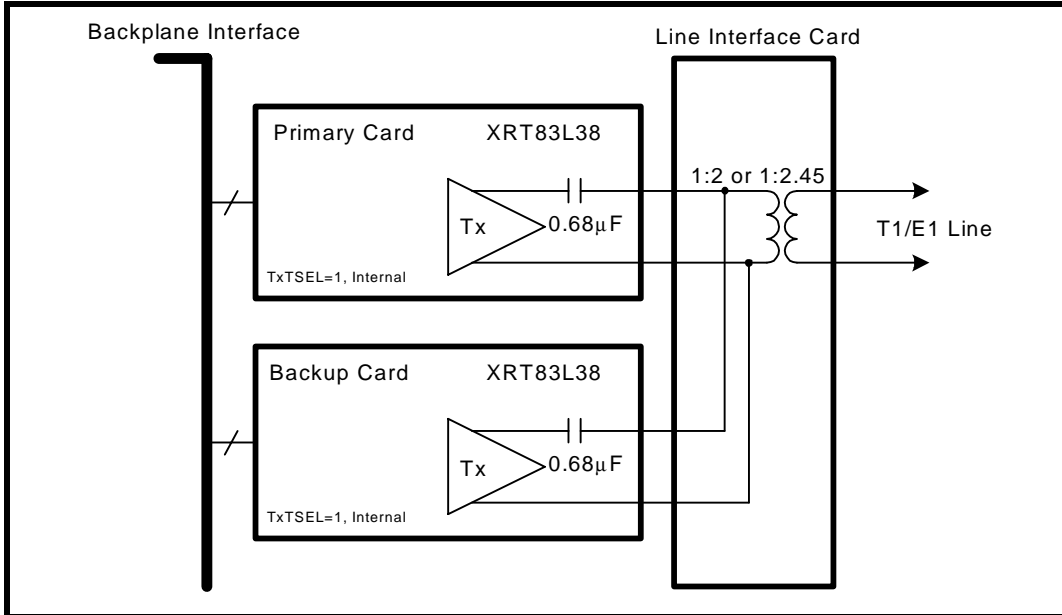

RECEIVE 1:1 & 1+1 REDUNDANCY

For 1:1 and 1+1 redundancy, the receivers on the primary card should be programmed for Internal Impedance mode. The receivers on the backup card should be programmed for External Impedance mode. Since there is no external resistor in the circuit, the receivers on the backup card will be high impedance. This key design feature eliminates the need for relays and provides one bill of materials for all interface modes of operation. Select the impedance for the desired mode of operation, T1/E1/J1. To swap the primary card, set the backup card to Internal Impedance mode, then the primary card to External Impedance mode. See Figure 17 for a simplified block diagram of the receive section for a 1:1 and 1+1 redundancy scheme.

NOTE: For simplification, the over voltage protection circuitry was omitted.

FIGURE 17. SIMPLIFIED BLOCK DIAGRAM - RECEIVE SECTION FOR 1:1 AND 1+1 REDUNDANCY

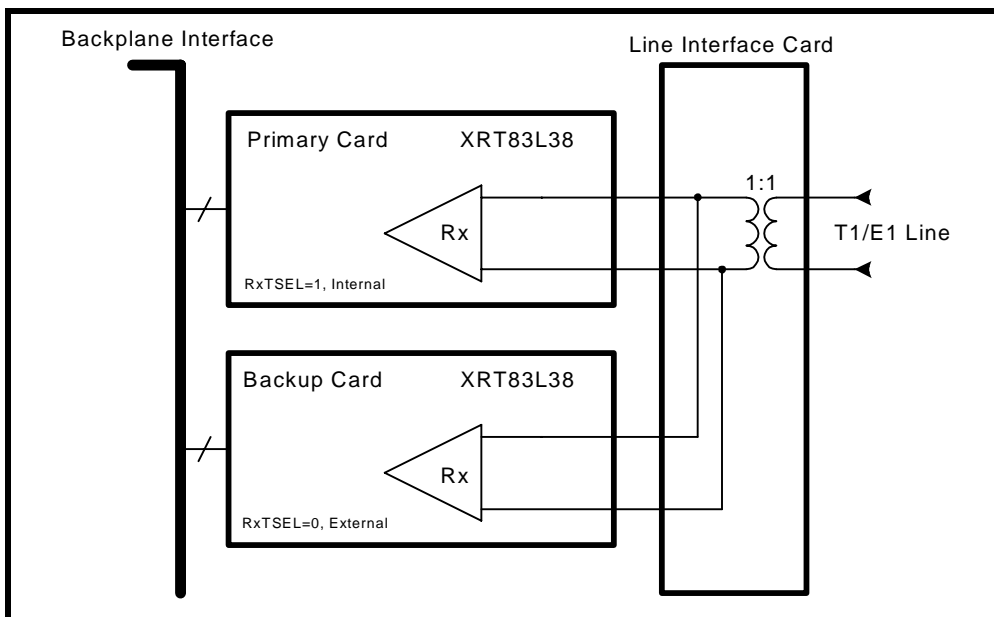

N+1 REDUNDANCY

N+1 redundancy has one backup card for N primary cards. Due to impedance mismatch and signal contention, external relays are necessary when using this redundancy scheme. The advantage of relays is that they create complete isolation between the primary cards and the backup card. This allows all transmitters and receivers on the primary cards to be configured in internal impedance mode, providing one bill of materials for all interface modes of operation. The transmit and receive sections of the XRT83L38 are described separately.

TRANSMIT

For N+1 redundancy, the transmitters on all cards should be programmed for internal impedance mode providing one bill of materials for T1/E1/J1. The transmitters on the backup card do not have to be tri-stated. To swap the primary card, close the desired relays, and tri-state the transmitters on the failed primary card. A 0.68µF capacitor is used in series with TTIP for blocking DC bias. See Figure 18 for a simplified block diagram of the transmit section for an N+1 redundancy scheme.

NOTE: For simplification, the over voltage protection circuitry was omitted.

FIGURE 18. SIMPLIFIED BLOCK DIAGRAM - TRANSMIT SECTION FOR N+1 REDUNDANCY

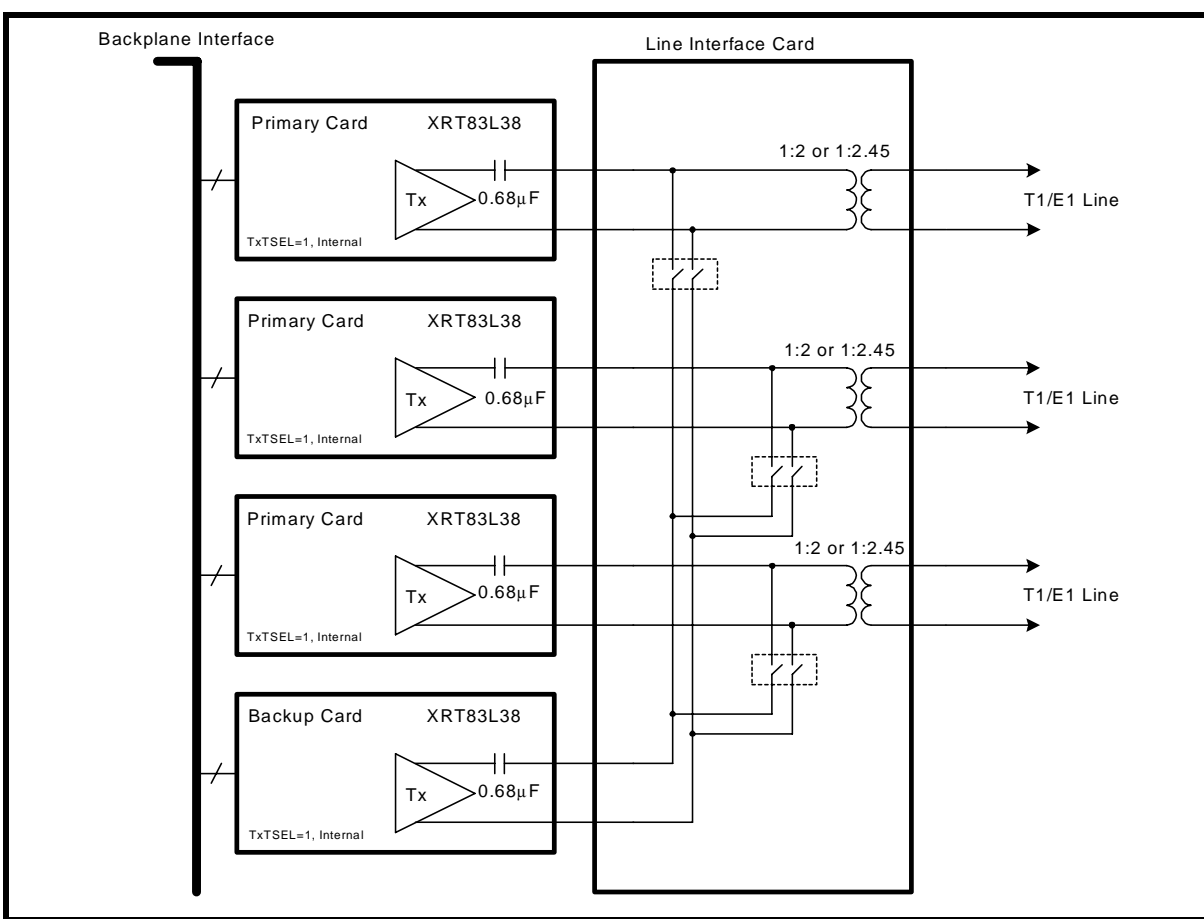

RECEIVE

For N+1 redundancy, the receivers on the primary cards should be programmed for internal impedance mode. The receivers on the backup card should be programmed for external impedance mode. Since there is no external resistor in the circuit, the receivers on the backup card will be high impedance. Select the impedance for the desired mode of operation, T1/E1/J1. To swap the primary card, set the backup card to internal impedance mode, then the primary card to external impedance mode. See **Figure 19**. for a simplified block diagram of the receive section for a N+1 redundancy scheme.

NOTE: For simplification, the over voltage protection circuitry was omitted.

FIGURE 19. SIMPLIFIED BLOCK DIAGRAM - RECEIVE SECTION FOR N+1 REDUNDANCY

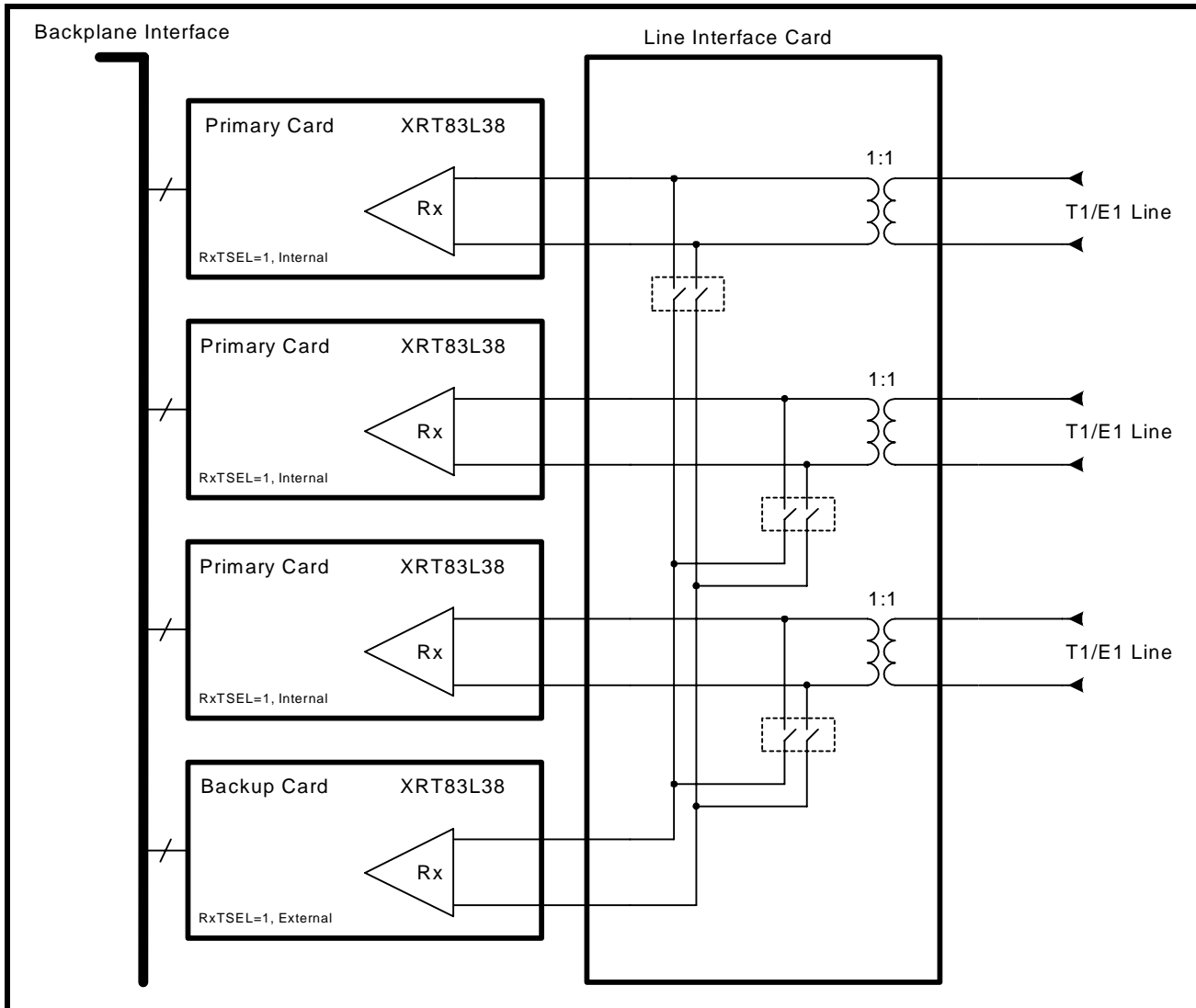

PATTERN TRANSMIT AND DETECT FUNCTION

Several test and diagnostic patterns can be generated and detected by the chip. In **Hardware** mode each channel can be independently programmed to transmit an All Ones pattern by applying a “High” level to the corresponding TAOS_n pin. In **Host** mode, the three interface bits TXTEST[2:0] control the pattern generation and detection independently for each channel according to **Table 12**.

TABLE 12: PATTERN TRANSMISSION CONTROL

TXTEST2	TXTEST1	TXTEST0	TEST PATTERN
0	x	x	None
1	0	0	TDQRSS
1	0	1	TAOS
1	1	0	TLUC
1	1	1	TLDC

TRANSMIT ALL ONES (TAOS)

This feature is available in both **Hardware** and **Host** modes. With the TAOS_n pin connected to a “High” level or when interface bits TXTEST2=“1”, TXTEST1=“0” and TXTEST0=“1” the transmitter ignores input from TPOS_n/TDATA_n and TNEG_n/CODES_n pins and sends a continuous AMI encoded all “Ones” signal to the line, using TCLK_n clock as the reference. In addition, when the **Hardware** pin and interface bit ATAOS is activated, the chip will automatically transmit the All “Ones” data from any channel that detects an RLOS condition. This feature is not available on a per channel basis. TCLK_n must NOT be tied “Low”.

NETWORK LOOP CODE DETECTION AND TRANSMISSION

This feature is available in **Host** mode only. When the interface bits TXTEST2=“1”, TXTEST1=“1” and TXTEST0=“0” the chip is enabled to transmit the “00001” Network Loop-Up Code from the selected channel requesting a Loop-Back condition from the remote terminal. Simultaneously setting the interface bits NLCDE1=“0” and NLCDE0=“1” enables the Network Loop-Up code detection in the receiver. If the “00001” Network Loop-Up code is detected in the receive data for longer than 5 seconds, the NLCD bit in the interface register is set indicating that the remote terminal has activated remote Loop-Back and the chip is receiving its own transmitted data. When the interface bits TXTEST2=“1”, TXTEST1=“1” and TXTEST0=“1” the chip is enabled to transmit the Network Loop-Down Code (TLDC) “001” from the selected channel requesting the remote terminal the removal of the Loop-Back condition.

In the **Host** mode each channel is capable of monitoring the contents of the receive data for the presence of Loop-Up or Loop-Down code from the remote terminal. In the **Host** mode the two interface bits NLCDE[1:0] control the Loop-Code detection independently for each channel according to **Table 13**.

TABLE 13: LOOP-CODE DETECTION CONTROL

NLCDE1	NLCDE0	CONDITION
0	0	Disable Loop-Code Detection
0	1	Detect Loop-Up Code in Receive Data
1	0	Detect Loop-Down Code in Receive Data
1	1	Automatic Loop-Code detection and Remote Loop-Back Activation

Setting the interface bits to NLCDE1=“0” and NLCDE0=“1” activates the detection of the Loop-Up code in the receive data. If the “00001” Network Loop-Up code is detected in the receive data for longer than 5 seconds, the NLCD interface bit is set to “1” and stays in this state for as long as the receiver continues to receive the

Network Loop-Up Code. In this mode if the NLCD interrupt is enabled, the chip will initiate an interrupt on every transition of NLCD. The host has the option to ignore the request from the remote terminal, or to respond to the request and manually activate Remote Loop-Back. The host can subsequently activate the detection of the Loop-Down Code by setting NLCDE1="1" and NLCDE0="0". In this case, receiving the "001" Loop-Down Code for longer than 5 seconds will set the NLCD bit to "1" and if the NLCD interrupt is enabled, the chip will initiate an interrupt on every transition of NLCD. The host can respond to the request from the remote terminal and remove Loop-Back condition. In the manual Network Loop-Up (NLCDE1="0" and NLCDE0="1") and Loop-Down (NLCDE1="1" and NLCDE0="0") Code detection modes, the NLCD interface bit will be set to "1" upon receiving the corresponding code in excess of 5 seconds in the receive data. The chip will initiate an interrupt any time the status of the NLCD bit changes and the Network Loop-code interrupt is enabled.

In the **Host** mode, setting the interface bits NLCDE1="1" and NLCDE0="1" enables the automatic Loop-Code detection and Remote Loop-Back activation mode if, TXTEST[2:0] is NOT equal to "110". As this mode is initiated, the state of the NLCD interface bit is reset to "0" and the chip is programmed to monitor the receive input data for the Loop-Up Code. If the "00001" Network Loop-Up Code is detected in the receive data for longer than 5 seconds in addition to the NLCD bit in the interface register being set, Remote Loop-Back is automatically activated. The chip stays in remote Loop-Back even if it stops receiving the "00001" pattern. After the chip detects the Loop-Up code, sets the NLCD bit and enters Remote Loop-Back, it automatically starts monitoring the receive data for the Loop-Down code. In this mode however, the NLCD bit stays set even if the receiver stops receiving the Loop-Up code, which is an indication to the host that the Remote Loop-Back is still in effect. Remote Loop-Back is removed if the chip detects the "001" Loop-Down code for longer than 5 seconds. Detecting the "001" code also results in resetting the NLCD interface bit and initiating an interrupt. The Remote Loop-Back can also be removed by taking the chip out of the Automatic detection mode by programming it to operate in a different state. The chip will not respond to remote Loop-Back request if Local Analog Loop-Back is activated locally. When programmed in Automatic detection mode the NLCD interface bit stays "High" for the whole time the Remote Loop-Back is activated and initiates an interrupt any time the status of the NLCD bit changes provided the Network Loop-code interrupt is enabled.

TRANSMIT AND DETECT QUASI-RANDOM SIGNAL SOURCE (TDQRSS)

Each channel of XRT83L38 includes a QRSS pattern generation and detection block for diagnostic purposes that can be activated only in the **Host** mode by setting the interface bits TXTEST2="1", TXTEST1="0" and TXTEST0="0". For T1 systems, the QRSS pattern is a $2^{20}-1$ pseudo-random bit sequence (PRBS) with no more than 14 consecutive zeros. For E1 systems, the QRSS pattern is $2^{15}-1$ PRBS with an inverted output. With QRSS and Analog Local Loop-Back enabled simultaneously, and by monitoring the status of the QRPD interface bit, all main functional blocks within the transceiver can be verified.

When the receiver achieves QRSS synchronization with fewer than 4 errors in a 128 bits window, QRPD changes from "Low" to "High". After pattern synchronization, any bit error will cause QRPD to go "Low" for one clock cycle. If the QRPDIE bit is enabled, any transition on the QRPD bit will generate an interrupt.

With TDQRSS activated, a bit error can be inserted in the transmitted QRSS pattern by transitioning the INSBER interface bit from "0" to "1". Bipolar violation can also be inserted either in the QRSS pattern, or input data when operating in the single-rail mode by transitioning the INSBPV interface bit from "0" to "1". The state of INSBER and INSBPV bits are sampled on the rising edge of the TCLK_n. To insure the insertion of the bit error or bipolar violation, a "0" should be written in these bit locations before writing a "1".

LOOP-BACK MODES

The XRT83L38 supports several Loop-Back modes under both **Hardware** and **Host** control. In **Hardware** mode the two LOOP[1:0] pins control the Loop-Back functions for each channel independently according to **Table 14**.

TABLE 14: LOOP-BACK CONTROL IN HARDWARE MODE

LOOP1	LOOP0	LOOP-BACK MODE
0	0	None
0	1	Analog
1	0	Remote
1	1	Digital

In **Host** mode the Loop-Back functions are controlled by the three LOOP[2:0] interface bits. Each channel can be programmed independently according to **Table 15**.

TABLE 15: LOOP-BACK CONTROL IN HOST MODE

LOOP2	LOOP1	LOOP0	LOOP-BACK MODE
0	X	X	None
1	0	0	Dual
1	0	1	Analog
1	1	0	Remote
1	1	1	Digital

LOCAL ANALOG LOOP-BACK (ALOOP)

With Local Analog Loop-Back activated, the transmit data at TTIP and TRING are looped-back to the analog input of the receiver. External inputs at RTIP/RRING in this mode are ignored while valid transmit data continues to be sent to the line. Local Analog Loop-Back exercises most of the functional blocks of the XRT83L38 including the jitter attenuator which can be selected in either the transmit or receive paths. Local Analog Loop-Back is shown in **Figure 20**.

FIGURE 20. LOCAL ANALOG LOOP-BACK SIGNAL FLOW

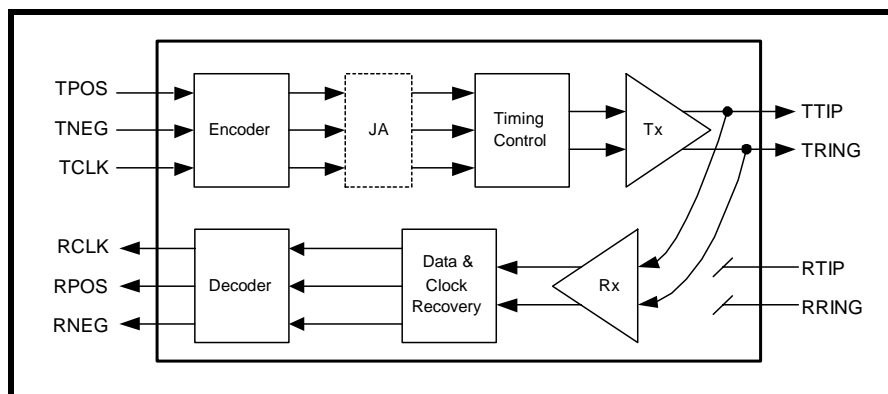

In this mode, the jitter attenuator (if selected) can be placed in the transmit or receive path.

OCTAL T1/E1/J1 LH/SH TRANSCEIVER WITH CLOCK RECOVERY AND JITTER ATTENUATOR

REMOTE LOOP-BACK (RLOOP)

With Remote Loop-Back activated, receive data after the jitter attenuator (if selected in the receive path) is looped back to the transmit path using RCLK as transmit timing. In this mode transmit clock and data are ignored, while RCLK and receive data will continue to be available at their respective output pins. Remote Loop-Back with jitter attenuator selected in the receive path is shown in **Figure 21**.

FIGURE 21. REMOTE LOOP-BACK MODE WITH JITTER ATTENUATOR SELECTED IN RECEIVE PATH

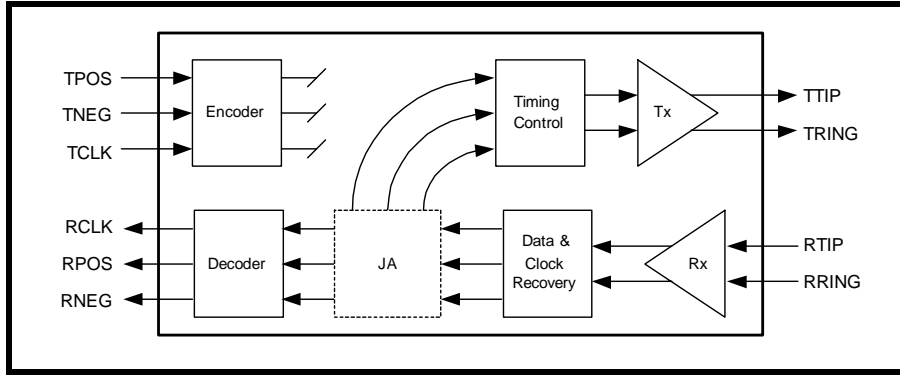

In the Remote Loop-Back mode if the jitter attenuator is selected in the transmit path, the receive data from the Clock and Data Recovery block is looped back to the transmit path and is applied to the jitter attenuator using RCLK as transmit timing. In this mode the transmit clock and data are also ignored, while RCLK and received data will continue to be available at their respective output pins. Remote Loop-Back with the jitter attenuator selected in the transmit path is shown in **Figure 22**.

FIGURE 22. REMOTE LOOP-BACK MODE WITH JITTER ATTENUATOR SELECTED IN TRANSMIT PATH

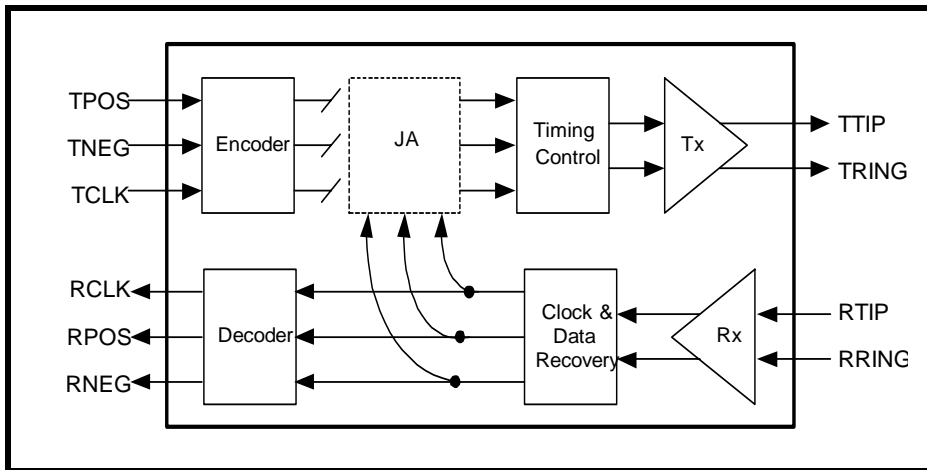

DIGITAL LOOP-BACK (DLOOP)

Digital Loop-Back or Local Loop-Back allows the transmit clock and data to be looped back to the corresponding receiver output pins through the encoder/decoder and jitter attenuator. In this mode, receive data and clock are ignored, but the transmit data will be sent to the line uninterrupted. This loop back feature allows users to configure the line interface as a pure jitter attenuator. The Digital Loop-Back signal flow is shown in **Figure 23**.

FIGURE 23. DIGITAL LOOP-BACK MODE WITH JITTER ATTENUATOR SELECTED IN TRANSMIT PATH

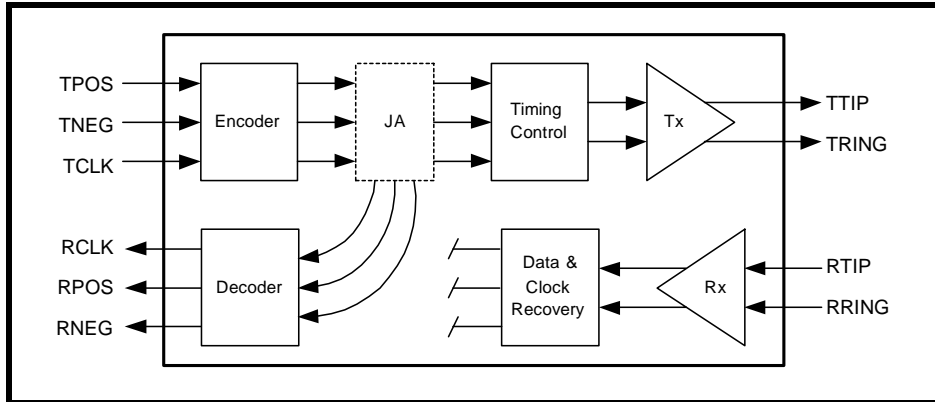

DUAL LOOP-BACK

Figure 24 depicts the data flow in dual-loopback. In this mode, selecting the jitter attenuator in the transmit path will have the same result as placing the jitter attenuator in the receive path. In dual Loop-Back mode the recovered clock and data from the line are looped back through the transmitter to the TTIP and TRING without passing through the jitter attenuator. The transmit clock and data are looped back through the jitter attenuator to the RCLK and RPOS/RDATA and RNEG pins.

FIGURE 24. SIGNAL FLOW IN DUAL LOOP-BACK MODE

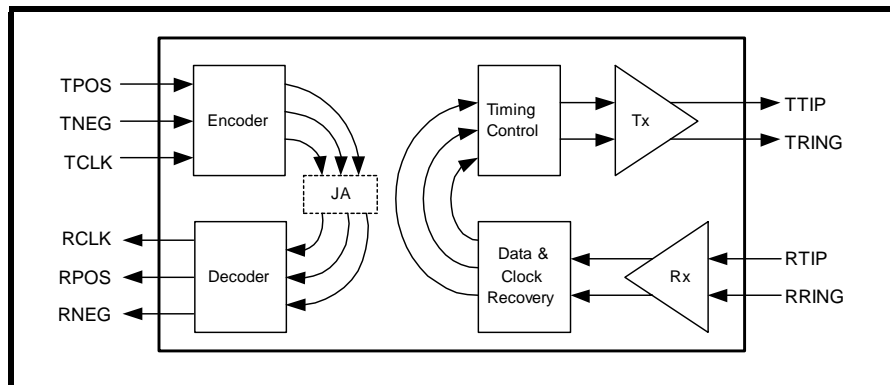

MICROPROCESSOR PARALLEL INTERFACE

XRT83L38 is equipped with a microprocessor interface for easy device configuration. The parallel port of the XRT83L38 is compatible with both Intel and Motorola address and data buses. The XRT83L38 has an 8-bit address A[7:0] input and 8-bit bi-directional data bus D[7:0]. The signals required for a generic microprocessor to access the internal registers are described in **Table 16**.

TABLE 16: MICROPROCESSOR INTERFACE SIGNAL DESCRIPTION

D[7:0]	Data Input (Output): 8 bits bi-directional Read/Write data bus for register access.															
A[7:0]	Address Input: 8 bit address to select internal register location.															
μ PTS1 μ PTS2	<p>Microprocessor Type Select:</p> <table border="1"> <thead> <tr> <th>μPTS2</th> <th>μPTS1</th> <th>μP Type</th> </tr> </thead> <tbody> <tr> <td>0</td> <td>0</td> <td>68HC11, 8051, 80C188 (async.)</td> </tr> <tr> <td>0</td> <td>1</td> <td>Motorola 68K (async.)</td> </tr> <tr> <td>1</td> <td>0</td> <td>Intel x86 (sync.)</td> </tr> <tr> <td>1</td> <td>1</td> <td>Intel i960, Motorola 860 (sync.)</td> </tr> </tbody> </table>	μ PTS2	μ PTS1	μ P Type	0	0	68HC11, 8051, 80C188 (async.)	0	1	Motorola 68K (async.)	1	0	Intel x86 (sync.)	1	1	Intel i960, Motorola 860 (sync.)
μ PTS2	μ PTS1	μ P Type														
0	0	68HC11, 8051, 80C188 (async.)														
0	1	Motorola 68K (async.)														
1	0	Intel x86 (sync.)														
1	1	Intel i960, Motorola 860 (sync.)														
μ PCLK	Microprocessor Clock Input: Input clock for synchronous microprocessor operation. Maximum clock speed is 54MHz. This pin is internally pulled "Low" for asynchronous microprocessor operation when no clock is present.															
ALE $\overline{\text{AS}}$	<p>Address Latch Input (Address Strobe):</p> <p>-Intel bus timing, the address inputs are latched into the internal register on the falling edge of ALE.</p> <p>-Motorola bus timing, the address inputs are latched into the internal register on the falling edge of $\overline{\text{AS}}$.</p>															
$\overline{\text{CS}}$	Chip Select Input: This signal must be "Low" in order to access the parallel port.															
$\overline{\text{RD}}$ $\overline{\text{DS}}$	<p>Read Input (Data Strobe):</p> <p>-Intel bus timing, a "Low" pulse on $\overline{\text{RD}}$ selects a read operation when $\overline{\text{CS}}$ pin is "Low".</p> <p>-Motorola bus timing, a "Low" pulse on $\overline{\text{DS}}$ indicates a read or write operation when $\overline{\text{CS}}$ pin is "Low".</p>															
$\overline{\text{WR}}$ $\overline{\text{R/W}}$	<p>Write Input (Read/Write):</p> <p>-Intel bus timing, a "Low" pulse on $\overline{\text{WR}}$ selects a write operation when $\overline{\text{CS}}$ pin is "Low".</p> <p>-Motorola bus timing, a "High" pulse on $\overline{\text{R/W}}$ selects a read operation and a "Low" pulse on $\overline{\text{R/W}}$ selects a write operation when $\overline{\text{CS}}$ pin is "Low".</p>															
RDY $\overline{\text{DTACK}}$	<p>Ready Output (Data Transfer Acknowledge Output):</p> <p>-Intel bus timing, RDY is asserted "High" to indicate the XRT83L38 has completed a read or write operation.</p> <p>-Motorola bus timing, $\overline{\text{DTACK}}$ is asserted "Low" to indicate the XRT83L38 has completed a read or write operation.</p>															
$\overline{\text{INT}}$	Interrupt Output: This pin is asserted "Low" to indicate an interrupt caused by an alarm condition in the device status registers. The activation of this pin can be blocked by setting the GIE bit to "0" in the Command Control register.															

MICROPROCESSOR REGISTER TABLES

The microprocessor interface consists of 256 addressable locations. Each channel uses 16 dedicated 8 byte registers for independent programming and control. There are four additional registers for global control of all channels and two registers for device identification and revision numbers. The remaining registers are for factory test and future expansion. The control register map and the function of the individual bits are summarized in Table 17 and Table 18 respectively.

TABLE 17: MICROPROCESSOR REGISTER ADDRESS

REGISTER NUMBER	REGISTER ADDRESS		FUNCTION
	HEX	BINARY	
0 - 15	0x00 - 0x0F	00000000 - 00001111	Channel 0 Control Registers
16 - 31	0x10 - 0x1F	00010000 - 00011111	Channel 1 Control Registers
32 - 47	0x20 - 0x2F	00100000 - 00101111	Channel 2 Control Registers
48 - 63	0x30 - 0x3F	00110000 - 00111111	Channel 3 Control Registers
64 - 79	0x40 - 0x4F	01000000 - 01001111	Channel 4 Control Registers
80 - 95	0x50 - 0x5F	01010000 - 01011111	Channel 5 Control Registers
96-111	0x60 - 0x6F	01100000 - 01101111	Channel 6 Control Registers
112 - 127	0x70 - 0x7F	01110000 - 01111111	Channel 7 Control Registers
128 - 131	0x80 - 0x83	10000000 - 10000011	Command Control registers for all 8 channels
132 -139	0x84 - 0x8B	10000100 - 10001011	R/W registers reserved for testing channels 0-3
140 - 191	0x8C - 0xBF	10001100 - 10111111	Reserved
192	0xC0	11000000	Command Control register for all 8 channels
193 - 195	0xC1 - 0xC3	11000001 - 11000011	Reserved
196 - 203	0xC4 - 0xCB	11000100 - 11001011	R/W registers reserved for testing channels 4-7
204 - 253	0xCC - 0xFD	11001100 - 11111101	Reserved
254	0xFE	11111110	Device "ID"
255	0xFF	11111111	Device "Revision ID"

TABLE 18: MICROPROCESSOR REGISTER BIT DESCRIPTION

REG. #	ADDRESS	REG. TYPE	Bit 7	Bit 6	Bit 5	Bit 4	Bit 3	Bit 2	Bit 1	Bit 0
Channel 0 Control Registers										
0	00000000 Hex 0x00	R/W	Reserved	Reserved	RXON_n	EQC4_n	EQC3_n	EQC2_n	EQC1_n	EQC0_n
1	00000001 Hex 0x01	R/W	RXTSEL_n	TXTSEL_n	TERSEL1_n	TERSEL0_n	JASEL1_n	JASEL0_n	JABW_n	FIFOS_n
2	00000010 Hex 0x02	R/W	INVQRSS_n	TXTEST2_n	TXTEST1_n	TXTEST0_n	TXON_n	LOOP2_n	LOOP1_n	LOOP0_n
3	00000011 Hex 0x03	R/W	NLCDE1_n	NLCDE0_n	CODES_n	RXRES1_n	RXRES0_n	INSBPV_n	INSBER_n	TRATIO_n

TABLE 18: MICROPROCESSOR REGISTER BIT DESCRIPTION

REG. #	ADDRESS	REG. TYPE	BIT 7	BIT 6	BIT 5	BIT 4	BIT 3	BIT 2	BIT 1	BIT 0
4	00000100 Hex 0x04	R/W	Reserved	DMOIE_n	FLSIE_n	LCVIE_n	NLCDIE_n	AISDIE_n	RLOSIE_n	QRPDIE_n
5	00000101 Hex 0x05	RO	Reserved	DMO_n	FLS_n	LCV_n	NLCD_n	AISD_n	RLOS_n	QRPD_n
6	00000110 Hex 0x06	RUR	Reserved	DMOIS_n	FLSIS_n	LCVIS_n	NLCDIS_n	AISDIS_n	RLOIS_n	QRPDIS_n
7	00000111 Hex 0x07	RO	Reserved	Reserved	CLOS5_n	CLOS4_n	CLOS3_n	CLOS2_n	CLOS1_n	CLOS0_n
8	00001000 Hex 0x08	R/W	X	B6S1_n	B5S1_n	B4S1_n	B3S1_n	B2S1_n	B1S1_n	B0S1_n
9	00001001 Hex 0x09	R/W	X	B6S2_n	B5S2_n	B4S2_n	B3S2_n	B2S2_n	B1S2_n	B0S2_n
10	00001010 Hex 0x0A	R/W	X	B6S3_n	B5S3_n	B4S3_n	B3S3_n	B2S3_n	B1S3_n	B0S3_n
11	00001011 Hex 0x0B	R/W	X	B6S4_n	B5S4_n	B4S4_n	B3S4_n	B2S4_n	B1S4_n	B0S4_n
12	00001100 Hex 0x0C	R/W	X	B6S5_n	B5S5_n	B4S5_n	B3S5_n	B2S5_n	B1S5_n	B0S5_n
13	00001101 Hex 0x0D	R/W	X	B6S6_n	B5S6_n	B4S6_n	B3S6_n	B2S6_n	B1S6_n	B0S6_n
14	00001110 Hex 0x0E	R/W	X	B6S7_n	B5S7_n	B4S7_n	B3S7_n	B2S7_n	B1S7_n	B0S7_n
15	00001111 Hex 0x0F	R/W	X	B6S8_n	B5S8_n	B4S8_n	B3S8_n	B2S8_n	B1S8_n	B0S8_n
			Reset = 0	Reset = 0	Reset = 0	Reset = 0	Reset = 0	Reset = 0	Reset = 0	Reset = 0
Command Control Global Registers for all 8 channels										
16-31	0001xxxx Hex 0x10-0x1F	R/W	Channel 1 Control Register (see Registers 0-15 for description)							
32-47	0010xxxx Hex 0x20-0x2F	R/W	Channel 2 Control Register (see Registers 0-15 for description)							
48-63	0011xxxx Hex 0x30-0x3F	R/W	Channel 3 Control Register (see Registers 0-15 for description)							
64-79	0100xxxx Hex 0x40-0x4F	R/W	Channel 4 Control Register (see Registers 0-15 for description)							
80-95	0101xxxx Hex 0x50-0x5F	R/W	Channel 5 Control Register (see Registers 0-15 for description)							
96-111	0110xxxx Hex 0x60-0x6F	R/W	Channel 6 Control Register (see Registers 0-15 for description)							
112-127	0111xxxx Hex 0x70-0x7F	R/W	Channel 7 Control Register (see Registers 0-15 for description)							
Command Control Registers for All 8 Channels										

TABLE 18: MICROPROCESSOR REGISTER BIT DESCRIPTION

REG. #	ADDRESS	REG. TYPE	Bit 7	Bit 6	Bit 5	Bit 4	Bit 3	Bit 2	Bit 1	Bit 0
128	10000000 Hex 0x80	R/W	SR/DR	ATAOS	RCLKE	TCLKE	DATAP	Reserved	GIE	SRESET
129	10000001 Hex 0x81	R/W	Reserved	CLKSEL2	CLKSEL1	CLKSEL0	MCLKRATE	RXMUTE	EXLOS	ICT
130	10000010 Hex 0x82	R/W	TXONCNTL	TERCNTL	Reserved	Reserved	MONITOR_3	MONITOR_2	MONITOR_1	MONITOR_0
131	10000011 Hex 0x83	R/W	GAUGE1	GAUGE0	Reserved	Reserved	SL_1	SL_0	EQG_1	EQG_0
Test Registers for channels 0 - 3										
132	10000100	R/W	Test byte 0							
133	10000101	R/W	Test byte 1							
134	10000110	R/W	Test byte 2							
135	10000111	R/W	Test byte 3							
136	10001000	R/W	Test byte 4							
137	10001001	R/W	Test byte 5							
138	10001010	R/W	Test byte 6							
139	10001011	R/W	Test byte 7							
Unused Registers										
140-191	100011xx									
Command Control Register for All 8 Channels										
192	11000000 Hex 0xC0	R/W	Reserved	Reserved	Reserved	Reserved	Reserved	Reserved	Reserved	E1Arben
Unused Registers										
193-195	110000xx									
Test Registers for channels 4 - 7										
196	11000100	R/W	Test byte 0							
197	11000101	R/W	Test byte 0							
198	11000110	R/W	Test byte 0							
199	11000111	R/W	Test byte 0							
200	11001000	R/W	Test byte 0							
201	11001001	R/W	Test byte 0							
202	11001010	R/W	Test byte 0							
203	11001011	R/W	Test byte 0							
Unused Registers										
204	11001100									
....										
253	11111101									
ID Registers										

TABLE 18: MICROPROCESSOR REGISTER BIT DESCRIPTION

REG. #	ADDRESS	REG. TYPE	BIT 7	BIT 6	BIT 5	BIT 4	BIT 3	BIT 2	BIT 1	BIT 0
254	11111110 Hex 0xFE	RO	DEVICE ID hex: FD - Binary 11111101							
255	11111111 Hex 0xFF	RO	DEVICE "Revision ID"							

MICROPROCESSOR REGISTER DESCRIPTIONS

TABLE 19: MICROPROCESSOR REGISTER #0, BIT DESCRIPTION

REGISTER ADDRESS	CHANNEL_n	FUNCTION	REGISTER TYPE	RESET VALUE
00000000	CHANNEL_0			
00010000	CHANNEL_1			
00100000	CHANNEL_2			
00110000	CHANNEL_3			
01000000	CHANNEL_4			
01010000	CHANNEL_5			
01100000	CHANNEL_6			
01110000	CHANNEL_7			
BIT #	NAME			
D7	Reserved		R/W	0
D6	Reserved		R/W	
D5	RXON_n	<p>Receiver ON: Writing a “1” into this bit location turns on the Receive Section of channel n. Writing a “0” shuts off the Receiver Section of channel n.</p> <p>NOTES:</p> <ol style="list-style-type: none"> <i>This bit provides independent turn-off or turn-on control of each receiver channel.</i> <i>In Hardware mode all receiver channels are always on in the TQFP package. In the BGA package all receiver channels can be turned on or off together by applying the appropriate signal to the RXON pin (# K16).</i> 	R/W	0
D4	EQC4_n	<p>Equalizer Control bit 4: This bit together with EQC[3:0] are used for controlling transmit pulse shaping, transmit line build-out (LBO) and receive monitoring for either T1 or E1 Modes of operation.</p> <p>See Table 5 for description of Equalizer Control bits.</p>	R/W	0
D3	EQC3_n	<p>Equalizer Control bit 3: See bit D4 description for function of this bit</p>	R/W	0
D2	EQC2_n	<p>Equalizer Control bit 2: See bit D4 description for function of this bit</p>	R/W	0
D1	EQC1_n	<p>Equalizer Control bit 1: See bit D4 description for function of this bit</p>	R/W	0
D0	EQC0_n	<p>Equalizer Control bit 0: See bit D4 description for function of this bit</p>	R/W	0

TABLE 20: MICROPROCESSOR REGISTER #1, BIT DESCRIPTION

REGISTER ADDRESS	CHANNEL_n	FUNCTION	REGISTER TYPE	RESET VALUE															
BIT #	NAME																		
00000001	CHANNEL_0																		
00010001	CHANNEL_1																		
00100001	CHANNEL_2																		
00110001	CHANNEL_3																		
01000001	CHANNEL_4																		
01010001	CHANNEL_5																		
01100001	CHANNEL_6																		
01110001	CHANNEL_7																		
D7	RXTSEL_n	<p>Receiver Termination Select: In Host mode, this bit is used to select between the internal and external line termination modes for the receiver according to the following table;</p> <table border="1"> <thead> <tr> <th>RXTSEL</th> <th>RX Termination</th> </tr> </thead> <tbody> <tr> <td>0</td> <td>External</td> </tr> <tr> <td>1</td> <td>Internal</td> </tr> </tbody> </table>	RXTSEL	RX Termination	0	External	1	Internal	R/W	0									
RXTSEL	RX Termination																		
0	External																		
1	Internal																		
D6	TXTSEL_n	<p>Transmit Termination Select: In Host mode, this bit is used to select between the internal and external line termination modes for the transmitter according to the following table;</p> <table border="1"> <thead> <tr> <th>TXTSEL</th> <th>TX Termination</th> </tr> </thead> <tbody> <tr> <td>0</td> <td>External</td> </tr> <tr> <td>1</td> <td>Internal</td> </tr> </tbody> </table>	TXTSEL	TX Termination	0	External	1	Internal	R/W	0									
TXTSEL	TX Termination																		
0	External																		
1	Internal																		
D5	TERSEL1_n	<p>Termination Impedance Select1: In Host mode and in internal termination mode, (TXTSEL = "1" and RXTSEL = "1") TERSEL[1:0] control the transmit and receive termination impedance according to the following table;</p> <table border="1"> <thead> <tr> <th>TERSEL1</th> <th>TERSEL0</th> <th>Termination</th> </tr> </thead> <tbody> <tr> <td>0</td> <td>0</td> <td>100Ω</td> </tr> <tr> <td>0</td> <td>1</td> <td>110Ω</td> </tr> <tr> <td>1</td> <td>0</td> <td>75Ω</td> </tr> <tr> <td>1</td> <td>1</td> <td>120Ω</td> </tr> </tbody> </table> <p>In the internal termination mode, the receiver termination of each receiver is realized completely by internal resistors or by the combination of internal and one fixed external resistor. In the internal termination mode, the transmitter output should be AC coupled to the transformer.</p>	TERSEL1	TERSEL0	Termination	0	0	100Ω	0	1	110Ω	1	0	75Ω	1	1	120Ω	R/W	0
TERSEL1	TERSEL0	Termination																	
0	0	100Ω																	
0	1	110Ω																	
1	0	75Ω																	
1	1	120Ω																	
D4	TERSEL0_n	Termination Impedance Select bit 0:	R/W	0															

TABLE 20: MICROPROCESSOR REGISTER #1, BIT DESCRIPTION

D3	JASEL1_n	<p>Jitter Attenuator select bit 1: The JASEL1 and JASEL0 bits are used to disable or place the jitter attenuator of each channel independently in the transmit or receive path.</p> <table border="1"> <thead> <tr> <th>JASEL1 bit D3</th> <th>JASEL0 bit D2</th> <th>JA Path</th> </tr> </thead> <tbody> <tr> <td>0</td> <td>0</td> <td>JA Disabled</td> </tr> <tr> <td>0</td> <td>1</td> <td>JA in Transmit Path</td> </tr> <tr> <td>1</td> <td>0</td> <td>JA in Receive Path</td> </tr> <tr> <td>1</td> <td>1</td> <td>JA in Receive Path</td> </tr> </tbody> </table>	JASEL1 bit D3	JASEL0 bit D2	JA Path	0	0	JA Disabled	0	1	JA in Transmit Path	1	0	JA in Receive Path	1	1	JA in Receive Path	R/W	0																														
JASEL1 bit D3	JASEL0 bit D2	JA Path																																															
0	0	JA Disabled																																															
0	1	JA in Transmit Path																																															
1	0	JA in Receive Path																																															
1	1	JA in Receive Path																																															
D2	JASEL0_n	<p>Jitter Attenuator select bit 0: See description of bit D3 for the function of this bit.</p>	R/W	0																																													
D1	JABW_n	<p>Jitter Attenuator Bandwidth Select: In E1 mode, set this bit to "1" to select a 1.5Hz Bandwidth for the Jitter Attenuator. The FIFO length will be automatically set to 64 bits. Set this bit to "0" to select 10Hz Bandwidth for the Jitter Attenuator in E1 mode. In T1 mode the Jitter Attenuator Bandwidth is permanently set to 3Hz, and the state of this bit has no effect on the Bandwidth.</p> <table border="1"> <thead> <tr> <th>Mode</th> <th>JABW bit D1</th> <th>FIFOS_n bit D0</th> <th>JA B-W Hz</th> <th>FIFO Size</th> </tr> </thead> <tbody> <tr> <td>T1</td> <td>0</td> <td>0</td> <td>3</td> <td>32</td> </tr> <tr> <td>T1</td> <td>0</td> <td>1</td> <td>3</td> <td>64</td> </tr> <tr> <td>T1</td> <td>1</td> <td>0</td> <td>3</td> <td>32</td> </tr> <tr> <td>T1</td> <td>1</td> <td>1</td> <td>3</td> <td>64</td> </tr> <tr> <td>E1</td> <td>0</td> <td>0</td> <td>10</td> <td>32</td> </tr> <tr> <td>E1</td> <td>0</td> <td>1</td> <td>10</td> <td>64</td> </tr> <tr> <td>E1</td> <td>1</td> <td>0</td> <td>1.5</td> <td>64</td> </tr> <tr> <td>E1</td> <td>1</td> <td>1</td> <td>1.5</td> <td>64</td> </tr> </tbody> </table>	Mode	JABW bit D1	FIFOS_n bit D0	JA B-W Hz	FIFO Size	T1	0	0	3	32	T1	0	1	3	64	T1	1	0	3	32	T1	1	1	3	64	E1	0	0	10	32	E1	0	1	10	64	E1	1	0	1.5	64	E1	1	1	1.5	64	R/W	0
Mode	JABW bit D1	FIFOS_n bit D0	JA B-W Hz	FIFO Size																																													
T1	0	0	3	32																																													
T1	0	1	3	64																																													
T1	1	0	3	32																																													
T1	1	1	3	64																																													
E1	0	0	10	32																																													
E1	0	1	10	64																																													
E1	1	0	1.5	64																																													
E1	1	1	1.5	64																																													
D0	FIFOS_n	<p>FIFO Size Select: See table of bit D1 above for the function of this bit.</p>	R/W	0																																													

TABLE 21: MICROPROCESSOR REGISTER #2, BIT DESCRIPTION

REGISTER ADDRESS	CHANNEL_n	FUNCTION	REGISTER TYPE	RESET VALUE																								
BIT #	NAME																											
00000010	CHANNEL_0																											
00010010	CHANNEL_1																											
00100010	CHANNEL_2																											
00110010	CHANNEL_3																											
01000010	CHANNEL_4																											
01010010	CHANNEL_5																											
01100010	CHANNEL_6																											
01110010	CHANNEL_7																											
D7	INVQRSS_n	Invert QRSS Pattern: When TQRSS is active, Writing a “1” to this bit inverts the polarity of transmitted QRSS pattern. Writing a “0” sends the QRSS pattern with no inversion.	R/W	0																								
D6	TXTEST2_n	<p>Transmit Test Pattern bit 2: This bit together with TXTEST1 and TXTEST0 are used to generate and transmit test patterns according to the following table:</p> <table border="1"> <thead> <tr> <th>TXTEST2</th> <th>TXTEST1</th> <th>TXTEST0</th> <th>Test Pattern</th> </tr> </thead> <tbody> <tr> <td>0</td> <td>X</td> <td>X</td> <td>No Pattern</td> </tr> <tr> <td>1</td> <td>0</td> <td>0</td> <td>TDQRSS</td> </tr> <tr> <td>1</td> <td>0</td> <td>1</td> <td>TAOS</td> </tr> <tr> <td>1</td> <td>1</td> <td>0</td> <td>TLUC</td> </tr> <tr> <td>1</td> <td>1</td> <td>1</td> <td>TLDC</td> </tr> </tbody> </table> <p>TDQRSS (Transmit/Detect Quasi-Random Signal): This condition when activated enables Quasi-Random Signal Source generation and detection for the selected channel number n. In a T1 system QRSS pattern is a 2²⁰-1 pseudo-random bit sequence (PRBS) with no more than 14 consecutive zeros. In a E1 system, QRSS is a 2¹⁵-1 PRBS pattern.</p> <p>TAOS (Transmit All Ones): Activating this condition enables the transmission of an All Ones Pattern from the selected channel number n.</p> <p>TLUC (Transmit Network Loop-Up Code): Activating this condition enables the Network Loop-Up Code of “00001” to be transmitted to the line for the selected channel number n. When Network Loop-Up code is being transmitted, the XRT83L38 will ignore the Automatic Loop-Code detection and Remote Loop-Back activation (NLCDE1 =“1”, NLCDE0 =“1”, if activated) in order to avoid activating Remote Digital Loop-Back automatically when the remote terminal responds to the Loop-Back request.</p> <p>TLDC (Transmit Network Loop-Down Code): Activating this condition enables the network Loop-Down Code of “001” to be transmitted to the line for the selected channel number n.</p>	TXTEST2	TXTEST1	TXTEST0	Test Pattern	0	X	X	No Pattern	1	0	0	TDQRSS	1	0	1	TAOS	1	1	0	TLUC	1	1	1	TLDC	R/W	0
TXTEST2	TXTEST1	TXTEST0	Test Pattern																									
0	X	X	No Pattern																									
1	0	0	TDQRSS																									
1	0	1	TAOS																									
1	1	0	TLUC																									
1	1	1	TLDC																									
D5	TXTEST1_n	Transmit Test pattern bit 1: See description of bit D6 for the function of this bit.	R/W	0																								

TABLE 21: MICROPROCESSOR REGISTER #2, BIT DESCRIPTION

D4	TXTEST0_n	Transmit Test Pattern bit 0: See description of bit D6 for the function of this bit.	R/W	0																								
D3	TXON_n	Transmitter ON: Writing a “1” into this bit location turns on the Transmit and Receive Sections of channel n. Writing a “0” shuts off the Transmit Section of channel n. In this mode, TTIP_n and TRING_n driver outputs will be tri-stated for power reduction or redundancy applications.	R/W	0																								
D2	LOOP2_n	<p>Loop-Back control bit 2: This bit together with the LOOP1 and LOOP0 bits control the Loop-Back modes of the chip according to the following table:</p> <table border="1" style="margin-left: auto; margin-right: auto;"> <thead> <tr> <th>LOOP2</th> <th>LOOP1</th> <th>LOOP0</th> <th>Loop-Back Mode</th> </tr> </thead> <tbody> <tr> <td>0</td> <td>X</td> <td>X</td> <td>No Loop-Back</td> </tr> <tr> <td>1</td> <td>0</td> <td>0</td> <td>Dual Loop-Back</td> </tr> <tr> <td>1</td> <td>0</td> <td>1</td> <td>Analog Loop-Back</td> </tr> <tr> <td>1</td> <td>1</td> <td>0</td> <td>Remote Loop-Back</td> </tr> <tr> <td>1</td> <td>1</td> <td>1</td> <td>Digital Loop-Back</td> </tr> </tbody> </table>	LOOP2	LOOP1	LOOP0	Loop-Back Mode	0	X	X	No Loop-Back	1	0	0	Dual Loop-Back	1	0	1	Analog Loop-Back	1	1	0	Remote Loop-Back	1	1	1	Digital Loop-Back		
LOOP2	LOOP1	LOOP0	Loop-Back Mode																									
0	X	X	No Loop-Back																									
1	0	0	Dual Loop-Back																									
1	0	1	Analog Loop-Back																									
1	1	0	Remote Loop-Back																									
1	1	1	Digital Loop-Back																									
D1	LOOP1_n	Loop-Back control bit 1: See description of bit D2 for the function of this bit.	R/W	0																								
D0	LOOP0_n	Loop-Back control bit 0: See description of bit D2 for the function of this bit.	R/W	0																								

TABLE 22: MICROPROCESSOR REGISTER #3, BIT DESCRIPTION

REGISTER ADDRESS	CHANNEL_n	FUNCTION	REGISTER TYPE	RESET VALUE															
00000011	CHANNEL_0																		
00010011	CHANNEL_1																		
00100011	CHANNEL_2																		
00110011	CHANNEL_3																		
01000011	CHANNEL_4																		
01010011	CHANNEL_5																		
01100011	CHANNEL_6																		
01110011	CHANNEL_7																		
BIT #	NAME																		
D7	NLCDE1_n	<p>Network Loop Code Detection Enable Bit 1: This bit together with NLCDE0_n control the Loop-Code detection of each channel.</p> <table border="1"> <thead> <tr> <th>NLCDE1</th> <th>NLCDE0</th> <th>Function</th> </tr> </thead> <tbody> <tr> <td>0</td> <td>0</td> <td>Disable Loop-code detection</td> </tr> <tr> <td>0</td> <td>1</td> <td>Detect Loop-Up code in receive data</td> </tr> <tr> <td>1</td> <td>0</td> <td>Detect Loop-Down code in receive data</td> </tr> <tr> <td>1</td> <td>1</td> <td>Automatic Loop-Code detection</td> </tr> </tbody> </table> <p>When NLCDE1 = "0" and NLCDE0 = "1" or NLCDE1 = "1" and NLCDE0 = "0", the chip is manually programmed to monitor the receive data for the Loop-Up or Loop-Down code respectively. When the presence of the "00001" or "001" pattern is detected for more than 5 seconds, the status of the NLCD bit is set to "1" and if the NLCD interrupt is enabled, an interrupt is initiated. The Host has the option to control the Loop-Back function manually.</p> <p>Setting the NLCDE1 = "1" and NLCDE0 = "1" enables the Automatic Loop-Code detection and Remote Loop-Back activation mode. As this mode is initiated, the state of the NLCD interface bit is reset to "0" and the chip is programmed to monitor the receive data for the Loop-Up code. If the "00001" pattern is detected for longer than 5 seconds, the NLCD bit is set "1", Remote Loop-Back is activated and the chip is automatically programmed to monitor the receive data for the Loop-Down code. The NLCD bit stays set even after the chip stops receiving the Loop-Up code. The Remote Loop-Back condition is removed when the chip receives the Loop-Down code for more than 5 seconds or if the Automatic Loop-Code detection mode is terminated.</p>	NLCDE1	NLCDE0	Function	0	0	Disable Loop-code detection	0	1	Detect Loop-Up code in receive data	1	0	Detect Loop-Down code in receive data	1	1	Automatic Loop-Code detection	R/W	0
NLCDE1	NLCDE0	Function																	
0	0	Disable Loop-code detection																	
0	1	Detect Loop-Up code in receive data																	
1	0	Detect Loop-Down code in receive data																	
1	1	Automatic Loop-Code detection																	
D6	NLCDE0_n	<p>Network Loop Code Detection Enable Bit 0: See description of D7 for function of this bit.</p>	R/W	0															
D5	CODES_n	<p>Encoding and Decoding Select: Writing a "0" to this bits selects HDB3 or B8ZS encoding and decoding for channel number n. Writing "1" selects an AMI coding scheme. This bit is only active when single rail mode is selected.</p>	R/W	0															

TABLE 22: MICROPROCESSOR REGISTER #3, BIT DESCRIPTION

D4	RXRES1_n	<p>Receive External Resistor Control Pin 1: In Host mode, this bit along with the RXRES0_n bit selects the value of the external Receive fixed resistor according to the following table;</p> <table border="1"> <thead> <tr> <th>RXRES1_n</th> <th>RXRES0_n</th> <th>Required Fixed External RX Resistor</th> </tr> </thead> <tbody> <tr> <td>0</td> <td>0</td> <td>No external Fixed Resistor</td> </tr> <tr> <td>0</td> <td>1</td> <td>240Ω</td> </tr> <tr> <td>1</td> <td>0</td> <td>210Ω</td> </tr> <tr> <td>1</td> <td>1</td> <td>150Ω</td> </tr> </tbody> </table>	RXRES1_n	RXRES0_n	Required Fixed External RX Resistor	0	0	No external Fixed Resistor	0	1	240Ω	1	0	210Ω	1	1	150Ω	R/W	0
RXRES1_n	RXRES0_n	Required Fixed External RX Resistor																	
0	0	No external Fixed Resistor																	
0	1	240Ω																	
1	0	210Ω																	
1	1	150Ω																	
D3	RXRES0_n	Receive External Resistor Control Pin 0: For function of this bit see description of D4 the RXRES1_n bit.	R/W	0															
D2	INSBPV_n	<p>Insert Bipolar Violation: When this bit transitions from “0” to “1”, a bipolar violation is inserted in the transmitted data stream of the selected channel number n. Bipolar violation can be inserted either in the QRSS pattern, or input data when operating in single-rail mode. The state of this bit is sampled on the rising edge of the respective TCLK_n.</p> <p>NOTE: To ensure the insertion of a bipolar violation, a “0” should be written in this bit location before writing a “1”.</p>	R/W	0															
D1	INSBER_n	<p>Insert Bit Error: With TDQRSS enabled, when this bit transitions from “0” to “1”, a bit error will be inserted in the transmitted QRSS pattern of the selected channel number n. The state of this bit is sampled on the rising edge of the respective TCLK_n.</p> <p>NOTE: To ensure the insertion of bit error, a “0” should be written in this bit location before writing a “1”.</p>	R/W	0															
D0	TRATIO_n	Transformer Ratio Select: In the external termination mode, writing a “1” to this bit selects a transformer ratio of 1:2 for the transmitter. Writing a “0” sets the transmitter transformer ratio to 1:2.45. In the internal termination mode the transmitter transformer ratio is permanently set to 1:2 and the state of this bit has no effect.	R/W	0															

TABLE 23: MICROPROCESSOR REGISTER #4, BIT DESCRIPTION

REGISTER ADDRESS	CHANNEL_n	FUNCTION	REGISTER TYPE	RESET VALUE
BIT #	NAME			
0000100	CHANNEL_0			
00010100	CHANNEL_1			
00100100	CHANNEL_2			
00110100	CHANNEL_3			
01000100	CHANNEL_4			
01010100	CHANNEL_5			
01100100	CHANNEL_6			
01110100	CHANNEL_7			

TABLE 23: MICROPROCESSOR REGISTER #4, BIT DESCRIPTION

D7	Reserved		RO	0
D6	DMOIE_n	DMO Interrupt Enable: Writing a “1” to this bit enables DMO interrupt generation, writing a “0” masks it.	R/W	0
D5	FLSIE_n	FIFO Limit Status Interrupt Enable: Writing a “1” to this bit enables interrupt generation when the FIFO limit is within to 3 bits, writing a “0” to masks it.	R/W	0
D4	LCVIE_n	Line Code Violation Interrupt Enable: Writing a “1” to this bit enables Line Code Violation interrupt generation, writing a “0” masks it.	R/W	0
D3	NLCDIE_n	Network Loop-Code Detection Interrupt Enable: Writing a “1” to this bit enables Network Loop-code detection interrupt generation, writing a “0” masks it.	R/W	0
D2	AISDIE_n	AIS Interrupt Enable: Writing a “1” to this bit enables Alarm Indication Signal detection interrupt generation, writing a “0” masks it.	R/W	0
D1	RLOSIE_n	Receive Loss of Signal Interrupt Enable: Writing a “1” to this bit enables Loss of Receive Signal interrupt generation, writing a “0” masks it.	R/W	0
D0	QRPDIE_n	QRSS Pattern Detection Interrupt Enable: Writing a “1” to this bit enables QRSS pattern detection interrupt generation, writing a “0” masks it.	R/W	0

TABLE 24: MICROPROCESSOR REGISTER #5, BIT DESCRIPTION

REGISTER ADDRESS	CHANNEL_n	FUNCTION	REGISTER TYPE	RESET VALUE
BIT #	NAME			
00000101	CHANNEL_0			
00010101	CHANNEL_1			
00100101	CHANNEL_2			
00110101	CHANNEL_3			
01000101	CHANNEL_4			
01010101	CHANNEL_5			
01100101	CHANNEL_6			
01110101	CHANNEL_7			
D7	Reserved		RO	0
D6	DMO_n	Driver Monitor Output: This bit is set to a “1” to indicate transmit driver failure is detected. The value of this bit is based on the current status of DMO for the corresponding channel. If the DMOIE bit is enabled, any transition on this bit will generate an Interrupt.	RO	0
D5	FLS_n	FIFO Limit Status: This bit is set to a “1” to indicate that the jitter attenuator read/write FIFO pointers are within +/- 3 bits. If the FLSIE bit is enabled, any transition on this bit will generate an Interrupt.	RO	0
D4	LCV_n	Line Code Violation: This bit is set to a “1” to indicate that the receiver of channel n is currently detecting a Line Code Violation or an excessive number of zeros in the B8ZS or HDB3 modes. If the LCVIE bit is enabled, any transition on this bit will generate an Interrupt.	RO	0

TABLE 24: MICROPROCESSOR REGISTER #5, BIT DESCRIPTION

D3	NLCD_n	<p>Network Loop-Code Detection:</p> <p>This bit operates differently in the Manual or the Automatic Network Loop-Code detection modes.</p> <p>In the Manual Loop-Code detection mode, (NLCDE1 = "0" and NLCDE0 = "1" or NLCDE1 = "1" and NLCDE0 = "0") this bit gets set to "1" as soon as the Loop-Up ("00001") or Loop-Down ("001") code is detected in the receive data for longer than 5 seconds. The NLCD bit stays in the "1" state for as long as the chip detects the presence of the Loop-code in the receive data and it is reset to "0" as soon as it stops receiving it. In this mode, if the NLCD interrupt is enabled, the chip will initiate an interrupt on every transition of the NLCD.</p> <p>When the Automatic Loop-code detection mode, (NLCDE1 = "1" and NLCDE0 = "1") is initiated, the state of the NLCD interface bit is reset to "0" and the chip is programmed to monitor the receive input data for the Loop-Up code. This bit is set to a "1" to indicate that the Network Loop Code is detected for more than 5 seconds. Simultaneously the Remote Loop-Back condition is automatically activated and the chip is programmed to monitor the receive data for the Network Loop Down code. The NLCD bit stays in the "1" state for as long as the Remote Loop-Back condition is in effect even if the chip stops receiving the Loop-Up code. Remote Loop-Back is removed if the chip detects the "001" pattern for longer than 5 seconds in the receive data. Detecting the "001" pattern also results in resetting the NLCD interface bit and initiating an interrupt provided the NLCD interrupt enable bit is active.</p> <p>When programmed in Automatic detection mode, the NLCD interface bit stays "High" for the entire time the Remote Loop-Back is active and initiate an interrupt anytime the status of the NLCD bit changes. In this mode, the Host can monitor the state of the NLCD bit to determine if the Remote Loop-Back is activated.</p>	RO	0
D2	AISD_n	<p>Alarm Indication Signal Detect: This bit is set to a "1" to indicate All Ones Signal is detected by the receiver. The value of this bit is based on the current status of Alarm Indication Signal detector of channel n. If the AISDIE bit is enabled, any transition on this bit will generate an Interrupt.</p>	RO	0
D1	RLOS_n	<p>Receive Loss of Signal: This bit is set to a "1" to indicate that the receive input signal is lost. The value of this bit is based on the current status of the receive input signal of channel n. If the RLOSIE bit is enabled, any transition on this bit will generate an Interrupt.</p>	RO	0
D0	QRPD_n	<p>Quasi-random Pattern Detection: This bit is set to a "1" to indicate the receiver is currently in synchronization with QRSS pattern. The value of this bit is based on the current status of Quasi-random pattern detector of channel n. If the QRPDIE bit is enabled, any transition on this bit will generate an Interrupt.</p>	RO	0

TABLE 25: MICROPROCESSOR REGISTER #6, BIT DESCRIPTION

REGISTER ADDRESS	CHANNEL_n	FUNCTION	REGISTER TYPE	RESET VALUE
BIT #	NAME			
00000110	CHANNEL_0			
00010110	CHANNEL_1			
00100110	CHANNEL_2			
00110110	CHANNEL_3			
01000110	CHANNEL_4			
01010110	CHANNEL_5			
01100110	CHANNEL_6			
01110110	CHANNEL_7			
D7	Reserved		RO	0
D6	DMOIS_n	Driver Monitor Output Interrupt Status: This bit is set to a “1” every time the DMO status has changed since last read. <i>NOTE: This bit is reset upon read.</i>	RUR	0
D5	FLSIS_n	FIFO Limit Interrupt Status: This bit is set to a “1” every time when FIFO Limit (Read/Write pointer with +/- 3 bits apart) status has changed since last read. <i>NOTE: This bit is reset upon read.</i>	RUR	0
D4	LCVIS_n	Line Code Violation Interrupt Status: This bit is set to a “1” every time when LCV status has changed since last read. <i>NOTE: This bit is reset upon read.</i>	RUR	0
D3	NLCDIS_n	Network Loop-Code Detection Interrupt Status: This bit is set to a “1” every time when NLCD status has changed since last read. <i>NOTE: This bit is reset upon read.</i>	RUR	0
D2	AISDIS_n	AIS Detection Interrupt Status: This bit is set to a “1” every time when AISD status has changed since last read. <i>NOTE: This bit is reset upon read.</i>	RUR	0
D1	RLOSI_n	Receive Loss of Signal Interrupt Status: This bit is set to a “1” every time RLOS status has changed since last read. <i>NOTE: This bit is reset upon read.</i>	RUR	0
D0	QRPDIS_n	Quasi-Random Pattern Detection Interrupt Status: This bit is set to a “1” every time when QRPD status has changed since last read. <i>NOTE: This bit is reset upon read.</i>	RUR	0

TABLE 26: MICROPROCESSOR REGISTER #7, BIT DESCRIPTION

REGISTER ADDRESS	CHANNEL_n	FUNCTION	REGISTER TYPE	RESET VALUE
BIT #	NAME			
00000111	CHANNEL_0			
00010111	CHANNEL_1			
00100111	CHANNEL_2			
00110111	CHANNEL_3			
01000111	CHANNEL_4			
01010111	CHANNEL_5			
01100111	CHANNEL_6			
01110111	CHANNEL_7			
D7	Reserved		RO	0
D6	Reserved		RO	0
D5	CLOS5_n	Cable Loss bit 5: CLOS[5:0]_n are the six bit receive selective equalizer setting which is also a binary word that represents the cable attenuation indication within ±1dB. CLOS5_n is the most significant bit (MSB) and CLOS0_n is the least significant bit (LSB).	RO	0
D4	CLOS4_n	Cable Loss bit 4: See description of D5 for function of this bit.	RO	0
D3	CLOS3_n	Cable Loss bit 3: See description of D5 for function of this bit.	RO	0
D2	CLOS2_n	Cable Loss bit 2: See description of D5 for function of this bit.	RO	0
D1	CLOS1_n	Cable Loss bit 1: See description of D5 for function of this bit.	RO	0
D0	CLOS0_n	Cable Loss bit 0: See description of D5 for function of this bit.	RO	0

TABLE 27: MICROPROCESSOR REGISTER #8, BIT DESCRIPTION

REGISTER ADDRESS	CHANNEL_n	FUNCTION	REGISTER TYPE	RESET VALUE
BIT #	NAME			
00001000	CHANNEL_0			
00011000	CHANNEL_1			
00101000	CHANNEL_2			
00111000	CHANNEL_3			
01001000	CHANNEL_4			
01011000	CHANNEL_5			
01101000	CHANNEL_6			
01111000	CHANNEL_7			
D7	Reserved		R/W	0
D6-D0	B6S1_n - B0S1_n	<p>Arbitrary Transmit Pulse Shape, Segment 1:The shape of each channel's transmitted pulse can be made independently user programmable by selecting "Arbitrary Pulse" mode in Table 5. The arbitrary pulse is divided into eight time segments whose combined duration is equal to one period of MCLK.</p> <p>This 7 bit number represents the amplitude of the nth channel's arbitrary pulse during the first time segment. B6S1_n-B0S1_n is in signed magnitude format with B6S1_n as the sign bit and B0S1_n as the least significant bit (LSB).</p>	R/W	0

TABLE 28: MICROPROCESSOR REGISTER #9, BIT DESCRIPTION

REGISTER ADDRESS	CHANNEL_n	FUNCTION	REGISTER TYPE	RESET VALUE
BIT #	NAME			
00001001	CHANNEL_0			
00011001	CHANNEL_1			
00101001	CHANNEL_2			
00111001	CHANNEL_3			
01001001	CHANNEL_4			
01011001	CHANNEL_5			
01101001	CHANNEL_6			
01111001	CHANNEL_7			
D7	Reserved		R/W	0
D6-D0	B6S2_n - B0S2_n	<p>Arbitrary Transmit Pulse Shape, Segment 2</p> <p>The shape of each channel's transmitted pulse can be made independently user programmable by selecting "Arbitrary Pulse" mode in Table 5. The arbitrary pulse is divided into eight time segments whose combined duration is equal to one period of MCLK.</p> <p>This 7 bit number represents the amplitude of the nth channel's arbitrary pulse during the second time segment. B6S2_n-B0S2_n is in signed magnitude format with B6S2_n as the sign bit and B0S2_n as the least significant bit (LSB).</p>	R/W	0

TABLE 29: MICROPROCESSOR REGISTER #10, BIT DESCRIPTION

REGISTER ADDRESS	CHANNEL_n	FUNCTION	REGISTER TYPE	RESET VALUE
BIT #	NAME			
00001010	CHANNEL_0			
00011010	CHANNEL_1			
00101010	CHANNEL_2			
00111010	CHANNEL_3			
01001010	CHANNEL_4			
01011010	CHANNEL_5			
01101010	CHANNEL_6			
01111010	CHANNEL_7			
D7	Reserved		R/W	0
D6-D0	B6S3_n - B0S3_n	<p>Arbitrary Transmit Pulse Shape, Segment 3</p> <p>The shape of each channel's transmitted pulse can be made independently user programmable by selecting "Arbitrary Pulse" mode in Table 5. The arbitrary pulse is divided into eight time segments whose combined duration is equal to one period of MCLK.</p> <p>This 7 bit number represents the amplitude of the nth channel's arbitrary pulse during the third time segment. B6S3_n-B0S3_n is in signed magnitude format with B6S3_n as the sign bit and B0S3_n as the least significant bit (LSB).</p>	R/W	0

TABLE 30: MICROPROCESSOR REGISTER #11, BIT DESCRIPTION

REGISTER ADDRESS	CHANNEL_n	FUNCTION	REGISTER TYPE	RESET VALUE
BIT #	NAME			
00001011	CHANNEL_0			
00011011	CHANNEL_1			
00101011	CHANNEL_2			
00111011	CHANNEL_3			
01001011	CHANNEL_4			
01011011	CHANNEL_5			
01101011	CHANNEL_6			
01111011	CHANNEL_7			
D7	Reserved		R/W	0
D6-D0	B6S4_n - B0S4_n	<p>Arbitrary Transmit Pulse Shape, Segment 4</p> <p>The shape of each channel's transmitted pulse can be made independently user programmable by selecting "Arbitrary Pulse" mode in Table 5. The arbitrary pulse is divided into eight time segments whose combined duration is equal to one period of MCLK.</p> <p>This 7 bit number represents the amplitude of the nth channel's arbitrary pulse during the fourth time segment. B6S4_n-B0S4_n is in signed magnitude format with B6S4_n as the sign bit and B0S4_n as the least significant bit (LSB).</p>	R/W	0

TABLE 31: MICROPROCESSOR REGISTER #12, BIT DESCRIPTION

REGISTER ADDRESS	CHANNEL_n	FUNCTION	REGISTER TYPE	RESET VALUE
BIT #	NAME			
00001100	CHANNEL_0			
00011100	CHANNEL_1			
00101100	CHANNEL_2			
00111100	CHANNEL_3			
01001100	CHANNEL_4			
01011100	CHANNEL_5			
01101100	CHANNEL_6			
01111100	CHANNEL_7			
D7	Reserved		R/W	0
D6-D0	B6S5_n - B0S5_n	<p>Arbitrary Transmit Pulse Shape, Segment 5</p> <p>The shape of each channel's transmitted pulse can be made independently user programmable by selecting "Arbitrary Pulse" mode in Table 5. The arbitrary pulse is divided into eight time segments whose combined duration is equal to one period of MCLK.</p> <p>This 7 bit number represents the amplitude of the nth channel's arbitrary pulse during the fifth time segment. B6S5_n-B0S5_n is in signed magnitude format with B6S5_n as the sign bit and B0S5_n as the least significant bit (LSB).</p>	R/W	0

TABLE 32: MICROPROCESSOR REGISTER #13, BIT DESCRIPTION

REGISTER ADDRESS	CHANNEL_n	FUNCTION	REGISTER TYPE	RESET VALUE
BIT #	NAME			
00001101	CHANNEL_0			
00011101	CHANNEL_1			
00101101	CHANNEL_2			
00111101	CHANNEL_3			
01001101	CHANNEL_4			
01011101	CHANNEL_5			
01101101	CHANNEL_6			
01111101	CHANNEL_7			
D7	Reserved		R/W	0
D6-D0	B6S6_n - B0S6_n	<p>Arbitrary Transmit Pulse Shape, Segment 6</p> <p>The shape of each channel's transmitted pulse can be made independently user programmable by selecting "Arbitrary Pulse" mode in Table 5. The arbitrary pulse is divided into eight time segments whose combined duration is equal to one period of MCLK.</p> <p>This 7 bit number represents the amplitude of the nth channel's arbitrary pulse during the sixth time segment. B6S6_n-B0S6_n is in signed magnitude format with B6S6_n as the sign bit and B0S6_n as the least significant bit (LSB).</p>	R/W	0

TABLE 33: MICROPROCESSOR REGISTER #14, BIT DESCRIPTION

REGISTER ADDRESS	CHANNEL_n	FUNCTION	REGISTER TYPE	RESET VALUE
BIT #	NAME			
00001110	CHANNEL_0			
00011110	CHANNEL_1			
00101110	CHANNEL_2			
00111110	CHANNEL_3			
01001110	CHANNEL_4			
01011110	CHANNEL_5			
01101110	CHANNEL_6			
01111110	CHANNEL_7			
D7	Reserved		R/W	0
D6-D0	B6S7_n - B0S7_n	<p>Arbitrary Transmit Pulse Shape, Segment 7</p> <p>The shape of each channel's transmitted pulse can be made independently user programmable by selecting "Arbitrary Pulse" mode in Table 5. The arbitrary pulse is divided into eight time segments whose combined duration is equal to one period of MCLK.</p> <p>This 7 bit number represents the amplitude of the nth channel's arbitrary pulse during the seventh time segment. B6S7_n-B0S7_n is in signed magnitude format with B6S7_n as the sign bit and B0S7_n as the least significant bit (LSB).</p>	R/W	0

TABLE 34: MICROPROCESSOR REGISTER #15, BIT DESCRIPTION

REGISTER ADDRESS	CHANNEL_n	FUNCTION	REGISTER TYPE	RESET VALUE
BIT #	NAME			
00001111	CHANNEL_0			
00011111	CHANNEL_1			
00101111	CHANNEL_2			
00111111	CHANNEL_3			
01001111	CHANNEL_4			
01011111	CHANNEL_5			
01101111	CHANNEL_6			
01111111	CHANNEL_7			
D7	Reserved		R/W	0
D6-D0	B6S8_n - B0S8_n	<p>Arbitrary Transmit Pulse Shape, Segment 8</p> <p>The shape of each channel's transmitted pulse can be made independently user programmable by selecting "Arbitrary Pulse" mode in Table 5. The arbitrary pulse is divided into eight time segments whose combined duration is equal to one period of MCLK.</p> <p>This 7 bit number represents the amplitude of the nth channel's arbitrary pulse during the eighth time segment. B6S8_n-B0S8_n is in signed magnitude format with B6S8_n as the sign bit and B0S8_n as the least significant bit (LSB).</p>	R/W	0

TABLE 35: MICROPROCESSOR REGISTER #128, BIT DESCRIPTION

REGISTER ADDRESS 10000000	NAME	FUNCTION	REGISTER TYPE	RESET VALUE
BIT #				
D7	SR/DR	Single-rail/Dual-rail Select: Writing a "1" to this bit configures all 8 channels in the XRT83L38 to operate in the Single-rail mode. Writing a "0" configures the XRT83L38 to operate in Dual-rail mode.	R/W	0
D6	ATAOS	Automatic Transmit All Ones Upon RLOS: Writing a "1" to this bit enables the automatic transmission of All "Ones" data to the line for the channel that detects an RLOS condition. Writing a "0" disables this feature.	R/W	0
D5	RCLKE	Receive Clock Edge: Writing a "1" to this bit selects receive output data of all channels to be updated on the negative edge of RCLK. Writing a "0" selects data to be updated on the positive edge of RCLK.	R/W	0
D4	TCLKE	Transmit Clock Edge: Writing a "0" to this bit selects transmit data at TPOS_n/TDATA_n and TNEG_n/CODES_n of all channels to be sampled on the falling edge of TCLK_n. Writing a "1" selects the rising edge of the TCLK_n for sampling.	R/W	0
D3	DATAP	DATA Polarity: Writing a "0" to this bit selects transmit input and receive output data of all channels to be active "High". Writing a "1" selects an active "Low" state.	R/W	0
D2	Reserved			0
D1	GIE	Global Interrupt Enable: Writing a "1" to this bit globally enables interrupt generation for all channels. Writing a "0" disables interrupt generation.	R/W	0
D0	SRESET	Software Reset μP Registers: Writing a "1" to this bit longer than 10 μ s initiates a device reset through the microprocessor interface. All internal circuits are placed in the reset state with this bit set to a "1" except the microprocessor register bits.	R/W	0

CLOCK SELECT REGISTER

The input clock source is used to generate all the necessary clock references internally to the LIU. The microprocessor timing is derived from a PLL output which is chosen by programming the Clock Select Bits and the Master Clock Rate in register 0x81h. Therefore, if the clock selection bits or the MCLRATE bit are being programmed, the frequency of the PLL output will be adjusted accordingly. During this adjustment, it is important to "Not" write to any other bit location within the same register while selecting the input/output clock frequency. For best results, register 0x81h can be broken down into two sub-registers with the MSB being bits D[7:3] and the LSB being bits D[2:0] as shown in **Figure 25**. Note: Bit D[7] is a reserved bit.

FIGURE 25. REGISTER 0X81H SUB REGISTERS

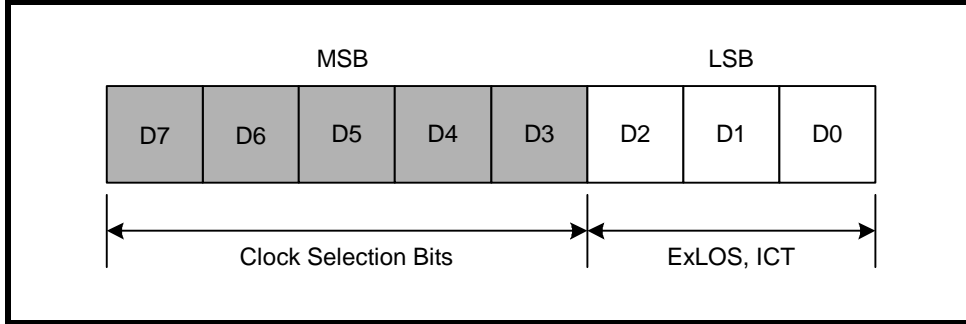

Programming Examples:

Example 1: Changing bits D[7:3]

If bits D[7:3] are the only values within the register that will change in a WRITE process, the microprocessor only needs to initiate ONE write operation.

Example 2: Changing bits D[2:0]

If bits D[2:0] are the only values within the register that will change in a WRITE process, the microprocessor only needs to initiate ONE write operation.

Example 3: Changing bits within the MSB and LSB

In this scenario, one must initiate TWO write operations such that the MSB and LSB do not change within ONE write cycle. It is recommended that the MSB and LSB be treated as two independent sub-registers. One can either change the clock selection (MSB) and then change bits D[2:0] (LSB) on the SECOND write, or vice-versa. No order or sequence is necessary.

TABLE 36: MICROPROCESSOR REGISTER #129, BIT DESCRIPTION

REGISTER ADDRESS 10000001	NAME	FUNCTION	REGISTER TYPE	RESET VALUE
BIT #				
D7	Reserved		R/W	0

TABLE 36: MICROPROCESSOR REGISTER #129, BIT DESCRIPTION

D6	CLKSEL2	<p>Clock Select Inputs for Master Clock Synthesizer bit 2: In Host mode, CLKSEL[2:0] are input signals to a programmable frequency synthesizer that can be used to generate a master clock from an external accurate clock source according to the following table;</p> <table border="1"> <thead> <tr> <th>MCLKE1 kHz</th> <th>MCLKT1 kHz</th> <th>CLKSEL2</th> <th>CLKSEL1</th> <th>CLKSEL0</th> <th>MCLKRATE</th> <th>CLKOUT/ kHz</th> </tr> </thead> <tbody> <tr><td>2048</td><td>2048</td><td>0</td><td>0</td><td>0</td><td>0</td><td>2048</td></tr> <tr><td>2048</td><td>2048</td><td>0</td><td>0</td><td>0</td><td>1</td><td>1544</td></tr> <tr><td>2048</td><td>1544</td><td>0</td><td>0</td><td>0</td><td>0</td><td>2048</td></tr> <tr><td>1544</td><td>1544</td><td>0</td><td>0</td><td>1</td><td>1</td><td>1544</td></tr> <tr><td>1544</td><td>1544</td><td>0</td><td>0</td><td>1</td><td>0</td><td>2048</td></tr> <tr><td>2048</td><td>1544</td><td>0</td><td>0</td><td>1</td><td>1</td><td>1544</td></tr> <tr><td>8</td><td>X</td><td>0</td><td>1</td><td>0</td><td>0</td><td>2048</td></tr> <tr><td>8</td><td>X</td><td>0</td><td>1</td><td>0</td><td>1</td><td>1544</td></tr> <tr><td>16</td><td>X</td><td>0</td><td>1</td><td>1</td><td>0</td><td>2048</td></tr> <tr><td>16</td><td>X</td><td>0</td><td>1</td><td>1</td><td>1</td><td>1544</td></tr> <tr><td>56</td><td>X</td><td>1</td><td>0</td><td>0</td><td>0</td><td>2048</td></tr> <tr><td>56</td><td>X</td><td>1</td><td>0</td><td>0</td><td>1</td><td>1544</td></tr> <tr><td>64</td><td>X</td><td>1</td><td>0</td><td>1</td><td>0</td><td>2048</td></tr> <tr><td>64</td><td>X</td><td>1</td><td>0</td><td>1</td><td>1</td><td>1544</td></tr> <tr><td>128</td><td>X</td><td>1</td><td>1</td><td>0</td><td>0</td><td>2048</td></tr> <tr><td>128</td><td>X</td><td>1</td><td>1</td><td>0</td><td>1</td><td>1544</td></tr> <tr><td>256</td><td>X</td><td>1</td><td>1</td><td>1</td><td>0</td><td>2048</td></tr> <tr><td>256</td><td>X</td><td>1</td><td>1</td><td>1</td><td>1</td><td>1544</td></tr> </tbody> </table> <p>In Hardware mode, the state of these signals are ignored and the master frequency PLL is controlled by the corresponding Hardware pins.</p>	MCLKE1 kHz	MCLKT1 kHz	CLKSEL2	CLKSEL1	CLKSEL0	MCLKRATE	CLKOUT/ kHz	2048	2048	0	0	0	0	2048	2048	2048	0	0	0	1	1544	2048	1544	0	0	0	0	2048	1544	1544	0	0	1	1	1544	1544	1544	0	0	1	0	2048	2048	1544	0	0	1	1	1544	8	X	0	1	0	0	2048	8	X	0	1	0	1	1544	16	X	0	1	1	0	2048	16	X	0	1	1	1	1544	56	X	1	0	0	0	2048	56	X	1	0	0	1	1544	64	X	1	0	1	0	2048	64	X	1	0	1	1	1544	128	X	1	1	0	0	2048	128	X	1	1	0	1	1544	256	X	1	1	1	0	2048	256	X	1	1	1	1	1544	R/W	0
MCLKE1 kHz	MCLKT1 kHz	CLKSEL2	CLKSEL1	CLKSEL0	MCLKRATE	CLKOUT/ kHz																																																																																																																																			
2048	2048	0	0	0	0	2048																																																																																																																																			
2048	2048	0	0	0	1	1544																																																																																																																																			
2048	1544	0	0	0	0	2048																																																																																																																																			
1544	1544	0	0	1	1	1544																																																																																																																																			
1544	1544	0	0	1	0	2048																																																																																																																																			
2048	1544	0	0	1	1	1544																																																																																																																																			
8	X	0	1	0	0	2048																																																																																																																																			
8	X	0	1	0	1	1544																																																																																																																																			
16	X	0	1	1	0	2048																																																																																																																																			
16	X	0	1	1	1	1544																																																																																																																																			
56	X	1	0	0	0	2048																																																																																																																																			
56	X	1	0	0	1	1544																																																																																																																																			
64	X	1	0	1	0	2048																																																																																																																																			
64	X	1	0	1	1	1544																																																																																																																																			
128	X	1	1	0	0	2048																																																																																																																																			
128	X	1	1	0	1	1544																																																																																																																																			
256	X	1	1	1	0	2048																																																																																																																																			
256	X	1	1	1	1	1544																																																																																																																																			
D5	CLKSEL1	<p>Clock Select inputs for Master Clock Synthesizer bit 1: See description of bit D6 for function of this bit.</p>	R/W	0																																																																																																																																					
D4	CLKSEL0	<p>Clock Select inputs for Master Clock Synthesizer bit 0: See description of bit D6 for function of this bit.</p>	R/W	0																																																																																																																																					
D3	MCLKRATE	<p>Master clock Rate Select: The state of this bit programs the Master Clock Synthesizer to generate the T1/J1 or E1 clock. The Master Clock Synthesizer will generate the E1 clock when MCLKRATE = "0", and the T1/J1 clock when MCLKRATE = "1".</p>	R/W	0																																																																																																																																					
D2	RXMUTE	<p>Receive Output Mute: Writing a "1" to this bit, mutes receive outputs at RPOS/RDATA and RNEG/LCV pins to a "0" state for any channel that detects an RLOS condition. NOTE: RCLK is not muted.</p>	R/W	0																																																																																																																																					
D1	EXLOS	<p>Extended LOS: Writing a "1" to this bit extends the number of zeros at the receive input of each channel before RLOS is declared to 4096 bits. Writing a "0" reverts to the normal mode (175+75 bits for T1 and 32 bits for E1).</p>	R/W	0																																																																																																																																					
D0	ICT	<p>In-Circuit-Testing: Writing a "1" to this bit configures all the output pins of the chip in high impedance mode for In-Circuit-Testing. Setting the ICT bit to "1" is equivalent to connecting the Hardware ICT pin 88 to ground.</p>	R/W	0																																																																																																																																					

TABLE 37: MICROPROCESSOR REGISTER #130, BIT DESCRIPTION

REGISTER ADDRESS 10000010	NAME	FUNCTION	REGISTER TYPE	RESET VALUE
BIT #				
D7	TXONCNTL	<p>Transmit On Control: In Host mode, setting this bit to “1” transfers the control of the Transmit On/Off function to the TXON_n Hardware control pins.</p> <p><i>NOTE: This provides a faster On/Off capability for redundancy application.</i></p>	R/W	0
D6	TERCNTL	<p>Termination Control. In Host mode, setting this bit to “1” transfers the control of the RXTSEL to the RXTSEL Hardware control pin.</p> <p><i>NOTE: This provides a faster On/Off capability for redundancy application.</i></p>	R/W	0
D5-D4	Reserved			

TABLE 37: MICROPROCESSOR REGISTER #130, BIT DESCRIPTION

D3	MONITOR_3	<p>Protected Monitoring: With protected monitoring enabled, the receiver 7 inputs at RTIP_7 and RRING_7 are internally connected to one of the other seven transmit and receive channels. Receiver 7 recovers the input data and clock and output them to RPOS_7/RNEG_7 and RCLK_7 respectively. In addition, the data to be monitored can be routed to TTIP_7 and TRING_7 by means of activating Remote Loop-Back for channel 7.</p> <p>With MONITOR_[3:0] bits set to "0", the Protected Monitoring feature is disabled and the XRT83L38 is configured as an octal line transceiver.</p> <p style="text-align: center;">Protected Monitoring Channel Select</p> <table border="1" data-bbox="602 621 1182 1430"> <thead> <tr> <th>Monitor_3</th> <th>Monitor_2</th> <th>Monitor_1</th> <th>Monitor_0</th> <th>Selection</th> </tr> </thead> <tbody> <tr><td>0</td><td>0</td><td>0</td><td>0</td><td>No Monitoring</td></tr> <tr><td>0</td><td>0</td><td>0</td><td>1</td><td>Receiver 0</td></tr> <tr><td>0</td><td>0</td><td>1</td><td>0</td><td>Receiver 1</td></tr> <tr><td>0</td><td>0</td><td>1</td><td>1</td><td>Receiver 2</td></tr> <tr><td>0</td><td>1</td><td>0</td><td>0</td><td>Receiver 3</td></tr> <tr><td>0</td><td>1</td><td>0</td><td>1</td><td>Receiver 4</td></tr> <tr><td>0</td><td>1</td><td>1</td><td>0</td><td>Receiver 5</td></tr> <tr><td>0</td><td>1</td><td>1</td><td>1</td><td>Receiver 6</td></tr> <tr><td>1</td><td>0</td><td>0</td><td>0</td><td>No Monitoring</td></tr> <tr><td>1</td><td>0</td><td>0</td><td>1</td><td>Transmitter 0</td></tr> <tr><td>1</td><td>0</td><td>1</td><td>0</td><td>Transmitter 1</td></tr> <tr><td>1</td><td>0</td><td>1</td><td>1</td><td>Transmitter 2</td></tr> <tr><td>1</td><td>1</td><td>0</td><td>0</td><td>Transmitter 3</td></tr> <tr><td>1</td><td>1</td><td>0</td><td>1</td><td>Transmitter 4</td></tr> <tr><td>1</td><td>1</td><td>1</td><td>0</td><td>Transmitter 5</td></tr> <tr><td>1</td><td>1</td><td>1</td><td>1</td><td>Transmitter 6</td></tr> </tbody> </table>	Monitor_3	Monitor_2	Monitor_1	Monitor_0	Selection	0	0	0	0	No Monitoring	0	0	0	1	Receiver 0	0	0	1	0	Receiver 1	0	0	1	1	Receiver 2	0	1	0	0	Receiver 3	0	1	0	1	Receiver 4	0	1	1	0	Receiver 5	0	1	1	1	Receiver 6	1	0	0	0	No Monitoring	1	0	0	1	Transmitter 0	1	0	1	0	Transmitter 1	1	0	1	1	Transmitter 2	1	1	0	0	Transmitter 3	1	1	0	1	Transmitter 4	1	1	1	0	Transmitter 5	1	1	1	1	Transmitter 6	R/W	0
Monitor_3	Monitor_2	Monitor_1	Monitor_0	Selection																																																																																					
0	0	0	0	No Monitoring																																																																																					
0	0	0	1	Receiver 0																																																																																					
0	0	1	0	Receiver 1																																																																																					
0	0	1	1	Receiver 2																																																																																					
0	1	0	0	Receiver 3																																																																																					
0	1	0	1	Receiver 4																																																																																					
0	1	1	0	Receiver 5																																																																																					
0	1	1	1	Receiver 6																																																																																					
1	0	0	0	No Monitoring																																																																																					
1	0	0	1	Transmitter 0																																																																																					
1	0	1	0	Transmitter 1																																																																																					
1	0	1	1	Transmitter 2																																																																																					
1	1	0	0	Transmitter 3																																																																																					
1	1	0	1	Transmitter 4																																																																																					
1	1	1	0	Transmitter 5																																																																																					
1	1	1	1	Transmitter 6																																																																																					
D2	MONITOR_2	<p>Protected Monitoring: See description for MONITOR_3</p>	R/W	0																																																																																					
D1	MONITOR_1	<p>Protected Monitoring: See description for MONITOR_3</p>	R/W	0																																																																																					
D0	MONITOR_0	<p>Protected Monitoring: See description for MONITOR_3</p>	R/W	0																																																																																					

TABLE 38: MICROPROCESSOR REGISTER #131, BIT DESCRIPTION

REGISTER ADDRESS 10000000	NAME	FUNCTION	REGISTER TYPE	RESET VALUE															
BIT #																			
D7	GAUGE1	<p>Wire Gauge Selector Bit 1: This bit together with bit D6 are used to select wire gauge size as shown in the table below.</p> <table border="1"> <thead> <tr> <th>GAUGE1</th> <th>GAUGE0</th> <th>Wire Size</th> </tr> </thead> <tbody> <tr> <td>0</td> <td>0</td> <td>22 and 24 Gauge</td> </tr> <tr> <td>0</td> <td>1</td> <td>22 Gauge</td> </tr> <tr> <td>1</td> <td>0</td> <td>24 Gauge</td> </tr> <tr> <td>1</td> <td>1</td> <td>26 Gauge</td> </tr> </tbody> </table>	GAUGE1	GAUGE0	Wire Size	0	0	22 and 24 Gauge	0	1	22 Gauge	1	0	24 Gauge	1	1	26 Gauge	R/W	0
GAUGE1	GAUGE0	Wire Size																	
0	0	22 and 24 Gauge																	
0	1	22 Gauge																	
1	0	24 Gauge																	
1	1	26 Gauge																	
D6	GAUGE0	<p>Wire Gauge Selector Bit 0: See bit D7.</p>	R/W	0															
D5	Reserved		R/W	0															
D4	Reserved		R/W	0															
D3	SL_1	<p>Slicer Level Control bit 1: This bit and bit D2 control the slicing level for the slicer per the following table.</p> <table border="1"> <thead> <tr> <th>SL_1</th> <th>SL_0</th> <th>Slicer Mode</th> </tr> </thead> <tbody> <tr> <td>0</td> <td>0</td> <td>Normal</td> </tr> <tr> <td>0</td> <td>1</td> <td>Decrease by 5% from Normal</td> </tr> <tr> <td>1</td> <td>0</td> <td>Increase by 5% from Normal</td> </tr> <tr> <td>1</td> <td>1</td> <td>Normal</td> </tr> </tbody> </table>	SL_1	SL_0	Slicer Mode	0	0	Normal	0	1	Decrease by 5% from Normal	1	0	Increase by 5% from Normal	1	1	Normal	R/W	0
SL_1	SL_0	Slicer Mode																	
0	0	Normal																	
0	1	Decrease by 5% from Normal																	
1	0	Increase by 5% from Normal																	
1	1	Normal																	
D2	SL_0	<p>Slicer Level Control bit 0: See description bit D3.</p>	R/W	0															
D1	EQG_1	<p>Equalizer Gain Control bit 1: This bit together with bit D0 control the gain of the equalizer as shown in the table below.</p> <table border="1"> <thead> <tr> <th>EQG_1</th> <th>EQG_0</th> <th>Equalizer Gain</th> </tr> </thead> <tbody> <tr> <td>0</td> <td>0</td> <td>Normal</td> </tr> <tr> <td>0</td> <td>1</td> <td>Reduce Gain by 1 dB</td> </tr> <tr> <td>1</td> <td>0</td> <td>Reduce Gain by 3 dB</td> </tr> <tr> <td>1</td> <td>1</td> <td>Normal</td> </tr> </tbody> </table>	EQG_1	EQG_0	Equalizer Gain	0	0	Normal	0	1	Reduce Gain by 1 dB	1	0	Reduce Gain by 3 dB	1	1	Normal	R/W	0
EQG_1	EQG_0	Equalizer Gain																	
0	0	Normal																	
0	1	Reduce Gain by 1 dB																	
1	0	Reduce Gain by 3 dB																	
1	1	Normal																	
D0	EQG_0	<p>Equalizer Gain Control bit 0: See description of bit D1</p>	R/W	0															

TABLE 39: MICROPROCESSOR REGISTER #192, BIT DESCRIPTION

REGISTER ADDRESS 11000000	NAME	FUNCTION	REGISTER TYPE	RESET VALUE
BIT #				
D[7:1]	Reserved	These register bits are not used.	R/W	0
D0	E1Arben	<p>E1 Arbitrary Pulse Enable</p> <p>This bit is used to enable the Arbitrary Pulse Generators for shaping the transmit pulse shape when E1 mode is selected. If this bit is set to "1", all 8 channels will be configured for the Arbitrary Mode. However, each channel is individually controlled by programming the channel registers 0xn8 through 0xnF, where n is the number of the channel.</p> <p>"0" = Disabled (Normal E1 Pulse Shape ITU G.703) "1" = Arbitrary Pulse Enabled</p>	R/W	0

ELECTRICAL CHARACTERISTICS

TABLE 40: ABSOLUTE MAXIMUM RATINGS

Storage Temperature.....	-65°C to + 150°C
Operating Temperature.....	-40°C to + 85°C
Supply Voltage.....	-0.5V to + 3.8V
V _{IN}	-0.5V to + 5.5V

TABLE 41: DC DIGITAL INPUT AND OUTPUT ELECTRICAL CHARACTERISTICS

VDD=3.3V±5%, T _A =25°C, UNLESS OTHERWISE SPECIFIED					
PARAMETER	SYMBOL	MIN.	TYP.	MAX.	UNITS
Power Supply Voltage	VDD	3.13	3.3	3.46	V
Input High Voltage	V _{IH}	2.0	-	5.0	V
Input Low Voltage	V _{IL}	-0.5	-	0.8	V
Output High Voltage @ IOH = 2.0mA	V _{OH}	2.4	-	-	V
Output Low Voltage @ IOL = 2mA.	V _{OL}	-	-	0.4	V
Input Leakage Current (except Input pins with Pull-up or Pull- down resistor).	I _L	-	-	±10	µA
Input Capacitance	C _I	-	5.0	-	pF
Output Load Capacitance	C _L	-	-	25	pF

TABLE 42: XRT83L38 POWER CONSUMPTION

VDD=3.3V±5%, T _A =25°C, UNLESS OTHERWISE SPECIFIED									
MODE	SUPPLY VOLTAGE	IMPEDANCE	TERMINATION RESISTOR	TRANSFORMER RATIO		TYP.	MAX.	UNIT	TEST CONDITIONS
				RECEIVER	TRANSMITTER				
E1	3.3V	75Ω	Internal	1:1	1:2	1.96	2.16	W	100% "1's"
E1	3.3V	120Ω	Internal	1:1	1:2	1.85	2.04	W	100% "1's"
T1	3.3V	100Ω	Internal	1:1	1:2	1.95	2.15	W	100% "1's"
---	3.3V	---	External	---	---	429	472	mW	All transmitters off

TABLE 43: E1 RECEIVER ELECTRICAL CHARACTERISTICS

VDD=3.3V±5%, T _A = -40° to 85°C, UNLESS OTHERWISE SPECIFIED					
PARAMETER	MIN.	TYP.	MAX.	UNIT	TEST CONDITIONS
Receiver loss of signal:					Cable attenuation @1024kHz
Number of consecutive zeros before RLOS is set	10	175	255		
Input signal level at RLOS	15	20		dB	ITU-G.775, ETSI 300 233
RLOS De-asserted	12.5			dB	
Receiver Sensitivity (Short Haul with cable loss)	11			dB	With nominal pulse amplitude of 3.0V for 120Ω and 2.37V for 75Ω application. With -18dB interference signal added.
Receiver Sensitivity (Long Haul with cable loss)					With nominal pulse amplitude of 3.0V for 120Ω and 2.37V for 75Ω application. With -18dB interference signal added.
Nominal	0		36	dB	
Extended	0		43	dB	
Input Impedance		13		kΩ	
Input Jitter Tolerance:					
1 Hz	37			U _{lpp}	ITU G.823
10kHz-100kHz	0.2			U _{lpp}	
Recovered Clock Jitter					
Transfer Corner Frequency	-	36		kHz	ITU G.736
Peaking Amplitude			-0.5	dB	
Jitter Attenuator Corner Frequency (-3dB curve) (JABW=0) (JABW=1)					
	-	10	-	Hz	ITU G.736
		1.5		Hz	
Return Loss:					
51kHz - 102kHz	14	-	-	dB	ITU-G.703
102kHz - 2048kHz	20			dB	
2048kHz - 3072kHz	16			dB	

TABLE 44: T1 RECEIVER ELECTRICAL CHARACTERISTICS

VDD=3.3V±5%, T _A =-40° TO 85°C, UNLESS OTHERWISE SPECIFIED					
PARAMETER	MIN.	TYP.	MAX.	UNIT	TEST CONDITIONS
Receiver loss of signal:					
Number of consecutive zeros before RLOS is set	100	175	250		
Input signal level at RLOS	15	20	-	dB	Cable attenuation @772kHz
RLOS Clear	12.5	-	-	% ones	ITU-G.775, ETSI 300 233
Receiver Sensitivity (Short Haul with cable loss)	12	-		dB	With nominal pulse amplitude of 3.0V for 100Ω termination
Receiver Sensitivity (Long Haul with cable loss)	0	-	36	dB	With nominal pulse amplitude of 3.0V for 100Ω termination
Input Impedance		13	-	kΩ	
Jitter Tolerance:					
1Hz	138	-	-	U _{lpp}	AT&T Pub 62411
10kHz - 100kHz	0.4	-	-		
Recovered Clock Jitter					
Transfer Corner Frequency	-	9.8	-	KHz	TR-TSY-000499
Peaking Amplitude	-		0.1	dB	
Jitter Attenuator Corner Frequency (-3dB curve)	-	6		-Hz	AT&T Pub 62411
Return Loss:					
51kHz - 102kHz	-	20	-	dB	
102kHz - 2048kHz	-	25	-	dB	
2048kHz - 3072kHz	-	25	-	dB	

TABLE 45: E1 TRANSMIT RETURN LOSS REQUIREMENT

FREQUENCY	RETURN LOSS	
	G.703/CH-PTT	ETS 300166
51-102kHz	8dB	6dB
102-2048kHz	14dB	8dB
2048-3072kHz	10dB	8dB

TABLE 46: E1 TRANSMITTER ELECTRICAL CHARACTERISTICS

VDD=3.3V±5%, T _A =-40° TO 85°C, UNLESS OTHERWISE SPECIFIED					
PARAMETER	MIN.	TYP.	MAX.	UNIT	TEST CONDITIONS
AMI Output Pulse Amplitude:					Transformer with 1:2 ratio and internal termination.
75Ω Application	2.185	2.37	2.555	V	
120Ω Application	2.76	3.00	3.24	V	
Output Pulse Width	224	244	264	ns	
Output Pulse Width Ratio	0.95	-	1.05	-	ITU-G.703
Output Pulse Amplitude Ratio	0.95	-	1.05	-	ITU-G.703
Jitter Added by the Transmitter Output	-	0.025	0.05	U _{Ipp}	Broad Band with jitter free TCLK applied to the input.
Output Return Loss:					ETSI 300 166, CHPTT
51kHz -102kHz	8	-	-	dB	
102kHz-2048kHz	14	-	-	dB	
2048kHz-3072kHz	10	-	-	dB	

TABLE 47: T1 TRANSMITTER ELECTRICAL CHARACTERISTICS

VDD=3.3V±5%, T _A =-40° TO 85°C, UNLESS OTHERWISE SPECIFIED					
PARAMETER	MIN.	TYP.	MAX.	UNIT	TEST CONDITIONS
AMI Output Pulse Amplitude:	2.5	3.0	3.50	V	Transformer with 1:2 ratio and and Internal Termination.
Output Pulse Width	338	350	362	ns	ANSI T1.102
Output Pulse Width Imbalance	-	-	20	-	ANSI T1.102
Output Pulse Amplitude Imbalance	-	-	±200	mV	ANSI T1.102
Jitter Added by the Transmitter Output	-	0.025	0.05	U _{Ipp}	Broad Band with jitter free TCLK applied to the input.
Output Return Loss:					
51kHz -102kHz	-	15	-	dB	
102kHz-2048kHz	-	15	-	dB	
2048kHz-3072kHz	-	15	-	dB	

FIGURE 27. DSX-1 PULSE TEMPLATE (NORMALIZED AMPLITUDE)

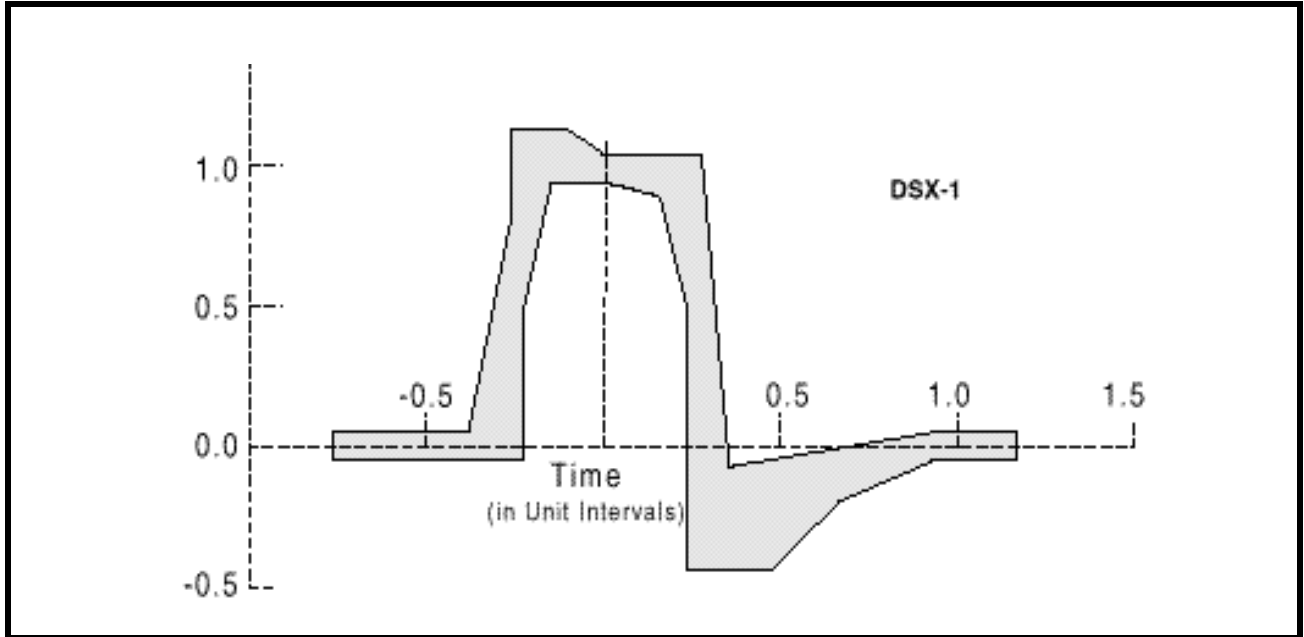

TABLE 49: DSX1 INTERFACE ISOLATED PULSE MASK AND CORNER POINTS

MINIMUM CURVE		MAXIMUM CURVE	
TIME (UI)	NORMALIZED AMPLITUDE	TIME (UI)	NORMALIZED AMPLITUDE
-0.77	-0.05V	-0.77	.05V
-0.23	-0.05V	-0.39	.05V
-0.23	0.5V	-0.27	.8V
-0.15	0.95V	-0.27	1.15V
0.0	0.95V	-0.12	1.15V
0.15	0.9V	0.0	1.05V
0.23	0.5V	0.27	1.05V
0.23	-0.45V	0.35	-0.07V
0.46	-0.45V	0.93	0.05V
0.66	-0.2V	1.16	0.05V
0.93	-0.05V		
1.16	-0.05V		

TABLE 50: AC ELECTRICAL CHARACTERISTICS

VDD=3.3V±5%, TA=25°C, UNLESS OTHERWISE SPECIFIED					
PARAMETER	SYMBOL	MIN.	TYP.	MAX.	UNITS
E1 MCLK Clock Frequency		-	2.048		MHz
T1 MCLK Clock Frequency		-	1.544		MHz
MCLK Clock Duty Cycle		40	-	60	%
MCLK Clock Tolerance		-	±50	-	ppm
TCLK Duty Cycle	T _{CDU}	30	50	70	%
Transmit Data Setup Time	T _{SU}	50	-	-	ns
Transmit Data Hold Time	T _{HO}	30	-	-	ns
TCLK Rise Time(10%/90%)	TCLK _R	-	-	40	ns
TCLK Fall Time(90%/10%)	TCLK _F	-	-	40	ns
RCLK Duty Cycle	R _{CDU}	45	50	55	%
Receive Data Setup Time	R _{SU}	150	-	-	ns
Receive Data Hold Time	R _{HO}	150	-	-	ns
RCLK to Data Delay	$\overline{\text{RDY}}$	-	-	40	ns
RCLK Rise Time(10% to 90%) with 25pF Loading.	RCLK _R	-	-	40	ns
RCLK Fall Time(90% to 10%) with 25pF Loading.	RCLK _F			40	ns

FIGURE 28. TRANSMIT CLOCK AND INPUT DATA TIMING

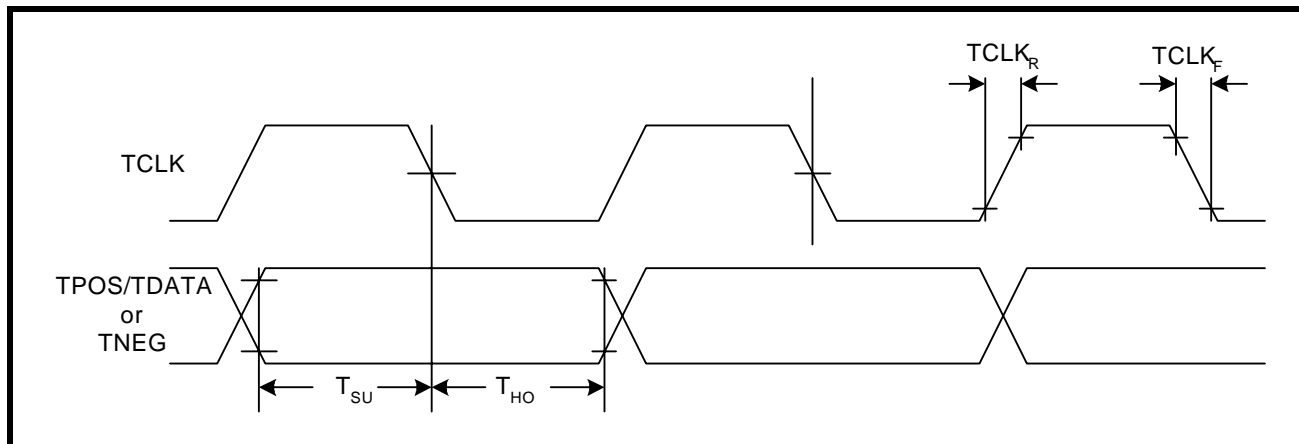
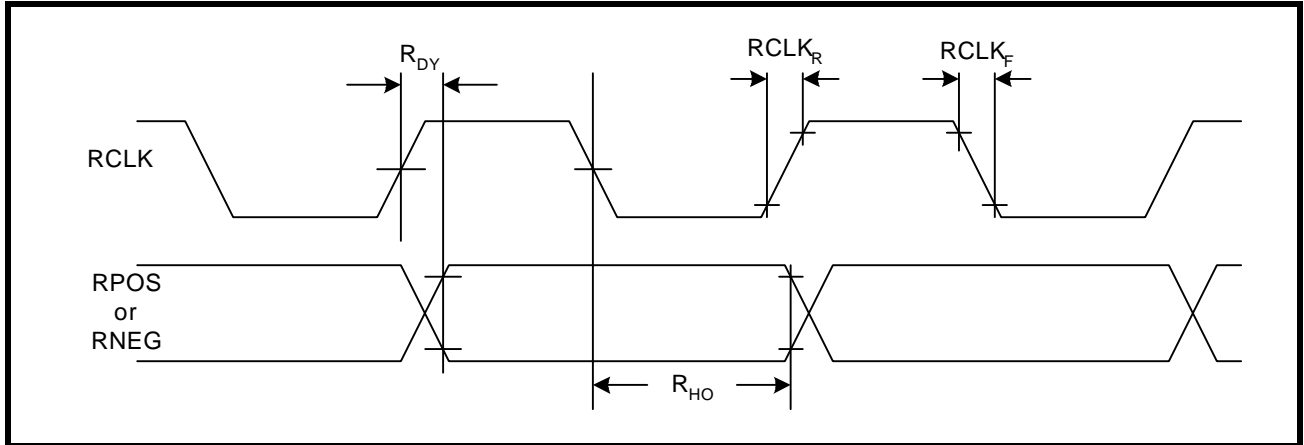

FIGURE 29. RECEIVE CLOCK AND OUTPUT DATA TIMING



MICROPROCESSOR INTERFACE I/O TIMING

INTEL INTERFACE TIMING - ASYNCHRONOUS

The signals used for the Intel microprocessor interface are: Address Latch Enable (ALE), Read Enable (\overline{RD}), Write Enable (\overline{WR}), Chip Select (\overline{CS}), Address and Data bits. The microprocessor interface uses minimum external glue logic and is compatible with the timings of the 8051 or 80C188 with an 8-16 MHz clock frequency, and with the timings of x86 or i960 family or microprocessors. The interface timing shown in **Figure 30** and **Figure 32** is described in **Table 51**.

FIGURE 30. INTEL ASYNCHRONOUS PROGRAMMED I/O INTERFACE TIMING

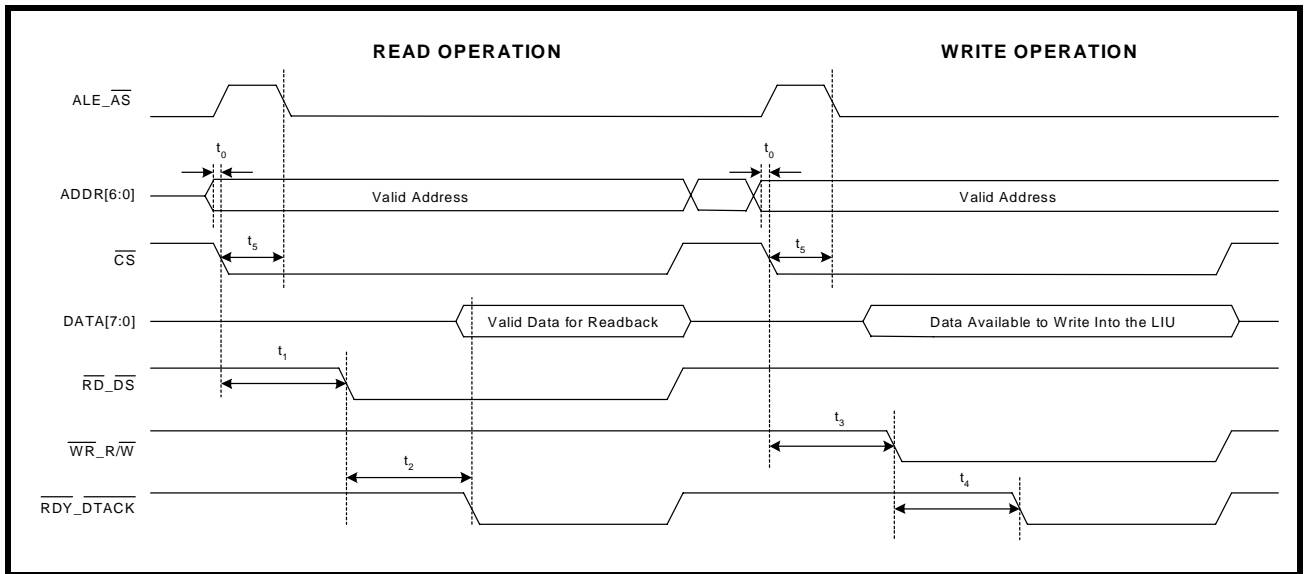

TABLE 51: ASYNCHRONOUS MODE 1 - INTEL 8051 AND 80188 INTERFACE TIMING

SYMBOL	PARAMETER	MIN	MAX	UNITS
t_0	Valid Address to \overline{CS} Falling Edge	0	-	ns
t_1	\overline{CS} Falling Edge to \overline{RD} Assert	20	-	ns
t_2	\overline{RD} Assert to \overline{RDY} Assert	-	135	ns
NA	\overline{RD} Pulse Width (t2)	135	-	ns
t_3	\overline{CS} Falling Edge to \overline{WR} Assert	20	-	ns
t_4	\overline{WR} Assert to RDY Assert	-	135	ns
NA	\overline{WR} Pulse Width (t2)	135	-	ns
t_5	\overline{CS} Falling Edge to AS Falling Edge	0	-	ns
Reset pulse width - both Motorola and Intel Operations (see Figure 32)				
t_9	\overline{Reset} pulse width	10		μ s

MOTOROLA ASYNCHRONOUS INTERFACE TIMING

The signals used in the Motorola microprocessor interface mode are: Address Strobe (AS), Data Strobe (\overline{DS}), Read/Write Enable ($\overline{R/W}$), Chip Select (\overline{CS}), Address and Data bits. The interface is compatible with the timing of a Motorola 68000 microprocessor family with up to 16.67 MHz clock frequency. The interface timing is shown in Figure 31 and Figure 32. The I/O specifications are shown in Table 52.

FIGURE 31. MOTOROLA 68K ASYNCHRONOUS PROGRAMMED I/O INTERFACE TIMING

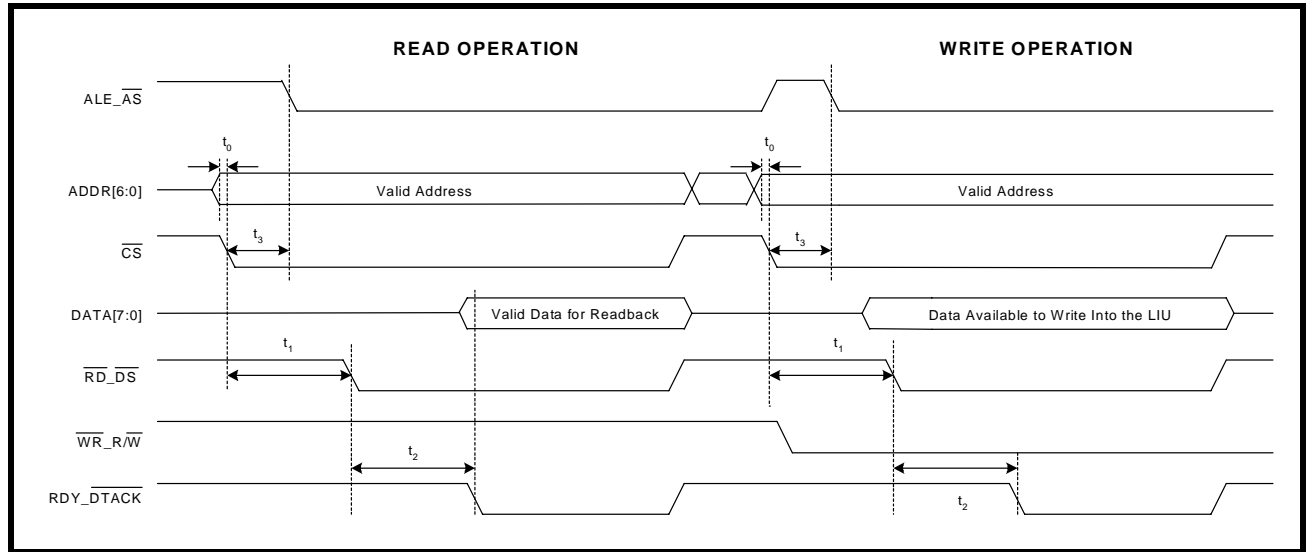
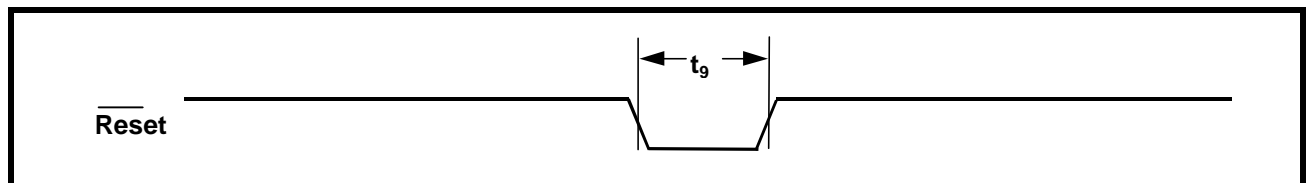

TABLE 52: ASYNCHRONOUS - MOTOROLA 68K - INTERFACE TIMING SPECIFICATION

SYMBOL	PARAMETER	MIN	MAX	UNITS
t_0	Valid Address to \overline{CS} Falling Edge	0	-	ns
t_1	\overline{CS} Falling Edge to \overline{DS} Assert	20	-	ns
t_2	\overline{DS} Assert to \overline{DTACK} Assert	-	135	ns
NA	\overline{DS} Pulse Width (t_2)	135	-	ns
t_3	\overline{CS} Falling Edge to \overline{AS} Falling Edge	0	-	ns
Reset pulse width - both Motorola and Intel Operations (see Figure 32)				
t_9	\overline{Reset} pulse width	10		μ s

FIGURE 32. MICROPROCESSOR INTERFACE TIMING - \overline{RESET} PULSE WIDTH



PACKAGE DIMENSIONS

225 BALL PLASTIC BALL GRID ARRAY (BOTTOM VIEW)
(19.0 X 19.0 X 1.0mm)

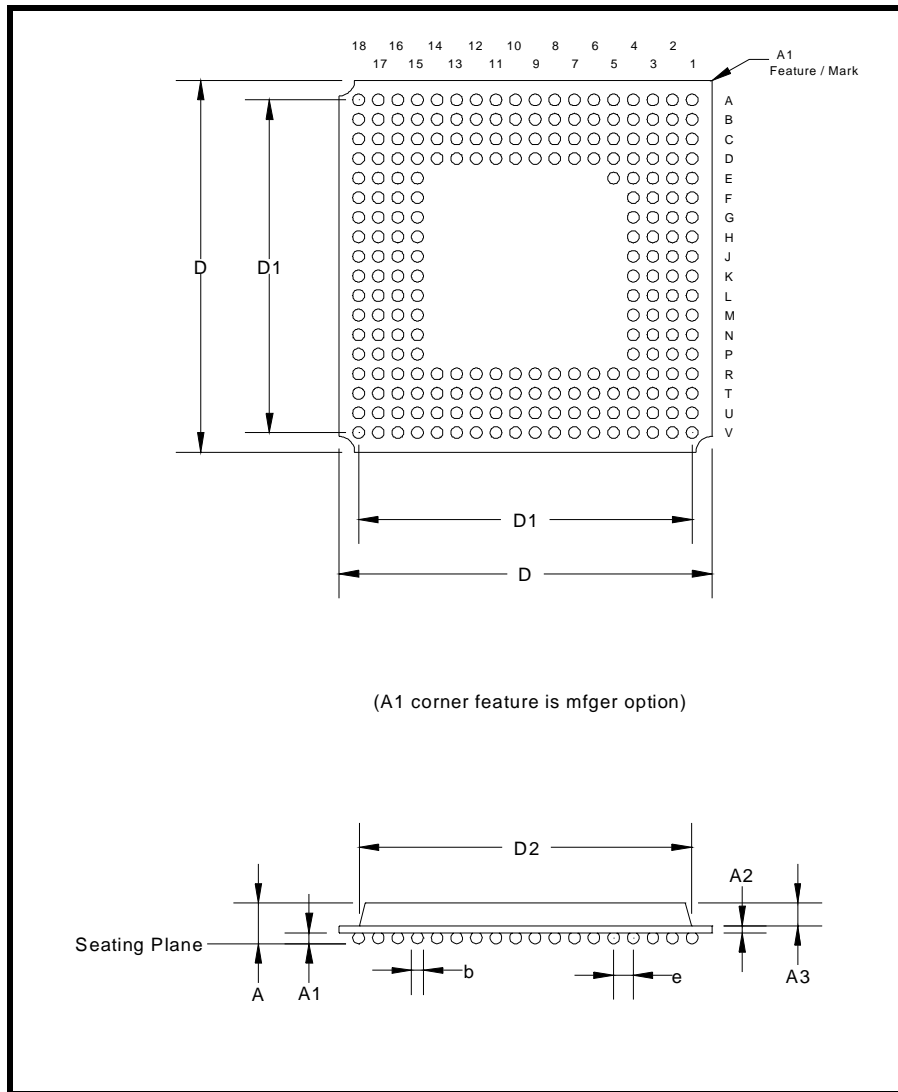

Note: The control dimension is in millimeter.

SYMBOL	INCHES		MILLIMETERS	
	MIN	MAX	MIN	MAX
A	0.049	0.096	1.24	2.45
A1	0.016	0.024	0.40	0.60
A2	0.013	0.024	0.32	0.60
A3	0.020	0.048	0.52	1.22
D	0.740	0.756	18.80	19.20
D1	0.669 BSC		17.00 BSC	
D2	0.665	0.669	16.90	17.00
b	0.020	0.028	0.50	0.70
e	0.039 BSC		1.00 BSC	

ORDERING INFORMATION

PART NUMBER	PACKAGE	OPERATING TEMPERATURE RANGE
XRT83L38IB	225 Ball BGA	-40°C to +85°C

REVISIONS

REVISION #	DATE	DESCRIPTION
1.0.0	06/04	Final Release. Fixed the typo RNEG1 Pin Number for the BGA Package to H2.
1.0.1	06/06	Added sentence to <u>RESET</u> pin (Exar recommends initiating a Hardware reset upon power up.) Changed t9 in table 51 and 52 to 10 (µs). Changed format to new Exar logo.
1.0.2	06/07	Remove XRT83L38IV product info.

NOTICE

EXAR Corporation reserves the right to make changes to the products contained in this publication in order to improve design, performance or reliability. EXAR Corporation assumes no responsibility for the use of any circuits described herein, conveys no license under any patent or other right, and makes no representation that the circuits are free of patent infringement. Charts and schedules contained here in are only for illustration purposes and may vary depending upon a user's specific application. While the information in this publication has been carefully checked; no responsibility, however, is assumed for inaccuracies.

EXAR Corporation does not recommend the use of any of its products in life support applications where the failure or malfunction of the product can reasonably be expected to cause failure of the life support system or to significantly affect its safety or effectiveness. Products are not authorized for use in such applications unless EXAR Corporation receives, in writing, assurances to its satisfaction that: (a) the risk of injury or damage has been minimized; (b) the user assumes all such risks; (c) potential liability of EXAR Corporation is adequately protected under the circumstances.

Copyright 2007 EXAR Corporation

Datasheet June 2007.

Reproduction, in part or whole, without the prior written consent of EXAR Corporation is prohibited.

Looking for pricing, stock, or lifecycle information?

Click below to explore more details on WIN SOURCE:

 [View XRT83L38IB-F on WIN SOURCE](#)

 [MaxLinear Inc Information](#)

Optimize Your Supply Chain with WIN SOURCE Solutions

-  Global Sourcing Solution
-  Obsolete Management
-  Cost Control Management
-  Shortage Management
-  Alternative Solution
-  Excess Inventory Management