

BGF117

High-Speed Mini-/Micro-SD Card ESD Protection
and EMI Filter

RF & Protection Devices



Edition 2010-01-15

**Published by
Infineon Technologies AG
81726 München, Germany**

**© Infineon Technologies AG 2010.
All Rights Reserved.**

Legal Disclaimer

The information given in this document shall in no event be regarded as a guarantee of conditions or characteristics ("Beschaffenhheitsgarantie"). With respect to any examples or hints given herein, any typical values stated herein and/or any information regarding the application of the device, Infineon Technologies hereby disclaims any and all warranties and liabilities of any kind, including without limitation warranties of non-infringement of intellectual property rights of any third party.

Information

For further information on technology, delivery terms and conditions and prices please contact your nearest Infineon Technologies Office (www.infineon.com).

Warnings

Due to technical requirements components may contain dangerous substances. For information on the types in question please contact your nearest Infineon Technologies Office.

Infineon Technologies Components may only be used in life-support devices or systems with the express written approval of Infineon Technologies, if a failure of such components can reasonably be expected to cause the failure of that life-support device or system, or to affect the safety or effectiveness of that device or system. Life support devices or systems are intended to be implanted in the human body, or to support and/or maintain and sustain and/or protect human life. If they fail, it is reasonable to assume that the health of the user or other persons may be endangered.

BGF117**Revision History: 2010-01-15, V2.0****Previous Version: 2009-09-28, V1.2**

Page	Subjects (major changes since last revision)
All	Target status removed

High-Speed Mini-/Micro-SD Card ESD Protection and EMI Filter

Features

- Bidirectional ESD protection and EMI filter for High-Speed Mini-/Micro-SD card interface
- ESD protection according to IEC61000-4-2 for ± 15 kV contact discharge on all external IOs
- ESD protection according to IEC61000-4-2 for ± 2 kV contact discharge on all internal IOs
- Very good EMI filtering and very low cross talk due to small package parasitics
- Suitable for high speed applications due to low line capacitance of typical 8 pF
- Very low voltage dependency of line capacitance
- Very low leakage currents
- Integrated pull up resistors to enable proper line biasing
- Application requires very low PCB area using an optimized I/O arrangement
- 400 μ m solder ball pitch
- RoHS and WEEE compliant package
- Complies with following standards:
SD Card Specification V2.0, MicroSD Card Specification V1.0

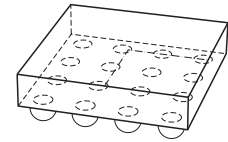

WLP-16-4-N

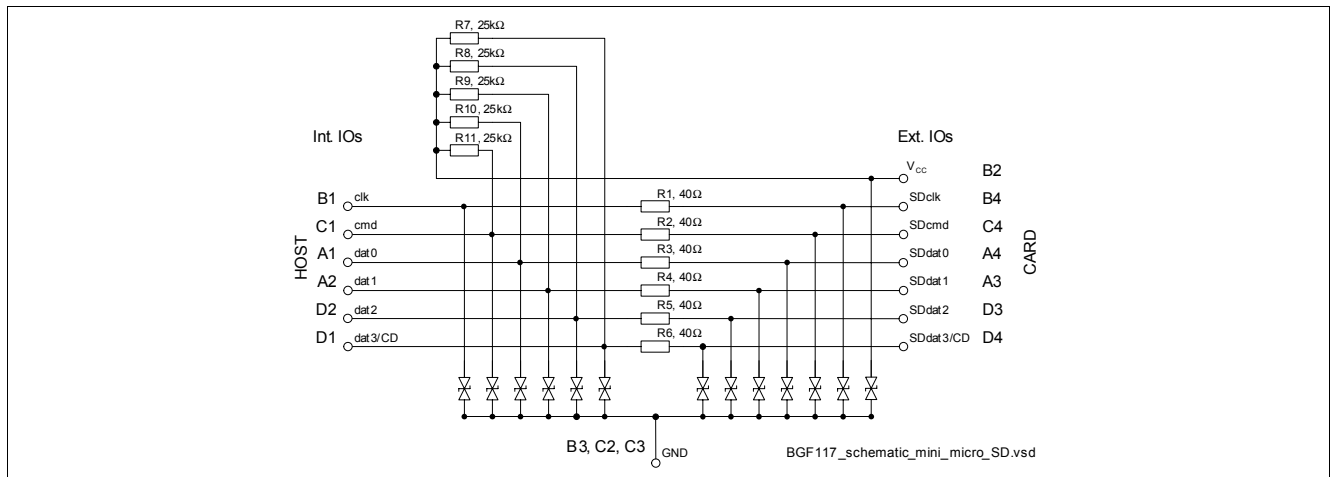

Figure 1 Schematic

Description

BGF117 is an ESD protection and EMI filter circuit for a high speed multi media card and mini-/micro-SD interface with integrated pull up resistors. External pins are protected for ± 15 kV contact discharge according to IEC61000-4-2. Due to the low electrical capacitance of each line BGF117 is well suited for high speed applications. The wafer level package is a green lead-free and halogen-free package with a size of only 1.55 mm x 1.55 mm and a total height of 0.6 mm.

Type	Package	Marking	Chip
BGF117	WLP-16-4	17	N0740

High-Speed Mini-/Micro-SD Card ESD Protection and EMI Filter

Table 1 Maximum Ratings

Parameter	Symbol	Values			Unit	Note / Test Condition
		Min.	Typ.	Max.		
Voltage at all pins to GND	V_P	0		5.5	V	
Operating temperature range	T_{OP}	-40		+85	°C	
Storage temperature range	T_{STG}	-65		+150	°C	
Electrostatic Discharge According to IEC61000-4-2						
External IOs: A3, A4, B2, B4, C4, D3, D4	V_E	-15		15	kV	Contact discharge
Internal IOs: A1, A2, B1, C1, D1, D2	V_I	-2		2	kV	Contact discharge

 Table 2 Electrical Characteristics¹⁾

Parameter	Symbol	Values			Unit	Note / Test Condition
		Min.	Typ.	Max.		
Resistors $R_1...R_6$	$R_{1...6}$	36	40	44	Ω	
Resistors $R_7...R_{11}$	$R_{7...11}$	20	25	30	k Ω	
Reverse current of ESD protection diodes	I_R		5	100	nA	$V_R = 3\text{ V}$
Breakdown voltage of ESD diodes ²⁾	$V_{(BR)}$	–	18.5 -12.5	–	V	$I_{(BR)} = 1\text{ mA}$ $I_{(BR)} = -1\text{ mA}$
Line capacitance ³⁾ Capacitance of each line to GND	C_T		8	9.5	pF	$V_R = 0\text{ V}$

 1) at $T_A = 25\text{ °C}$

2) After snap-back

3) B2 is connected to GND for measurement

Typical electrical characteristics

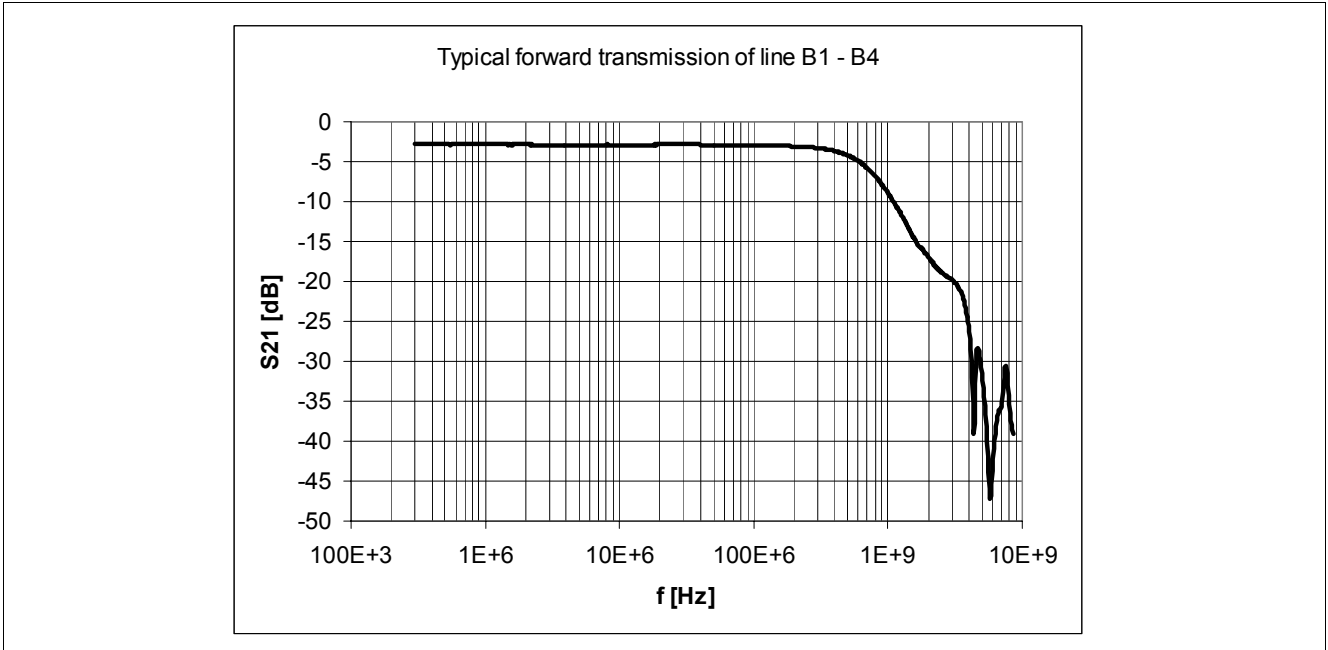

Figure 2 Typical filter characteristics of one filter channel ($Z_S = Z_L = 50 \text{ Ohm}$, $V_R = 0V$)

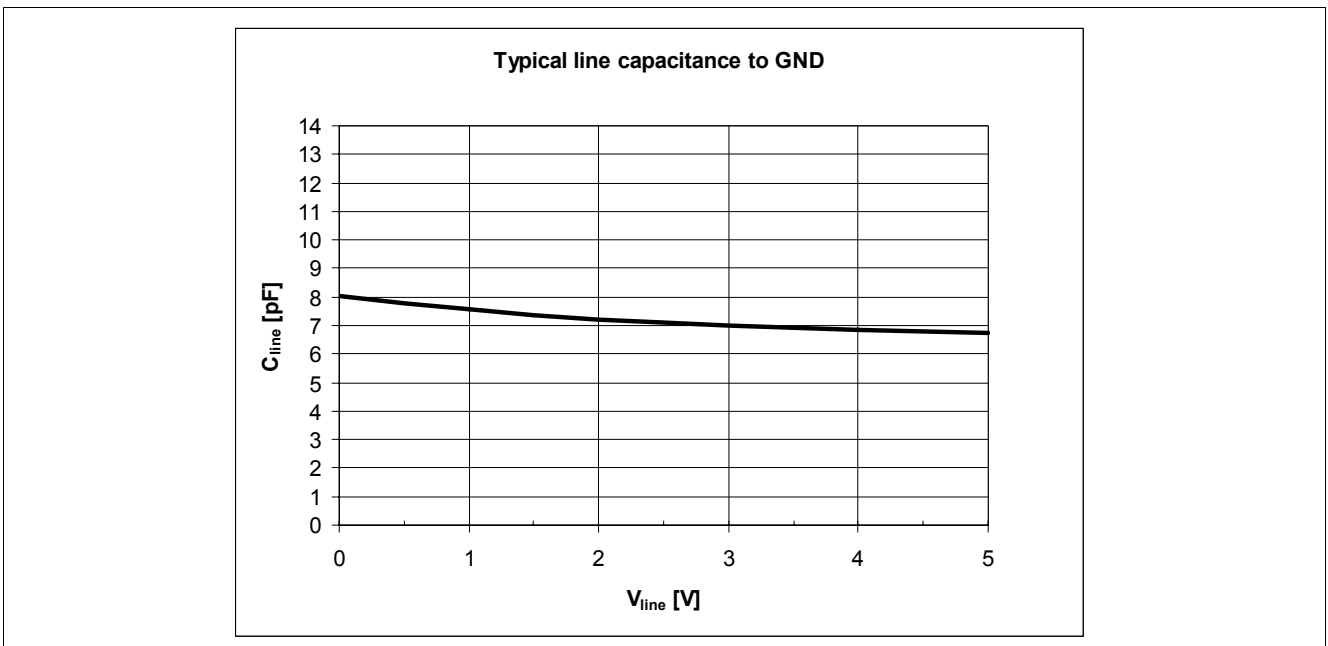

Figure 3 Typical line capacitance versus bias voltage

Application & signal routing

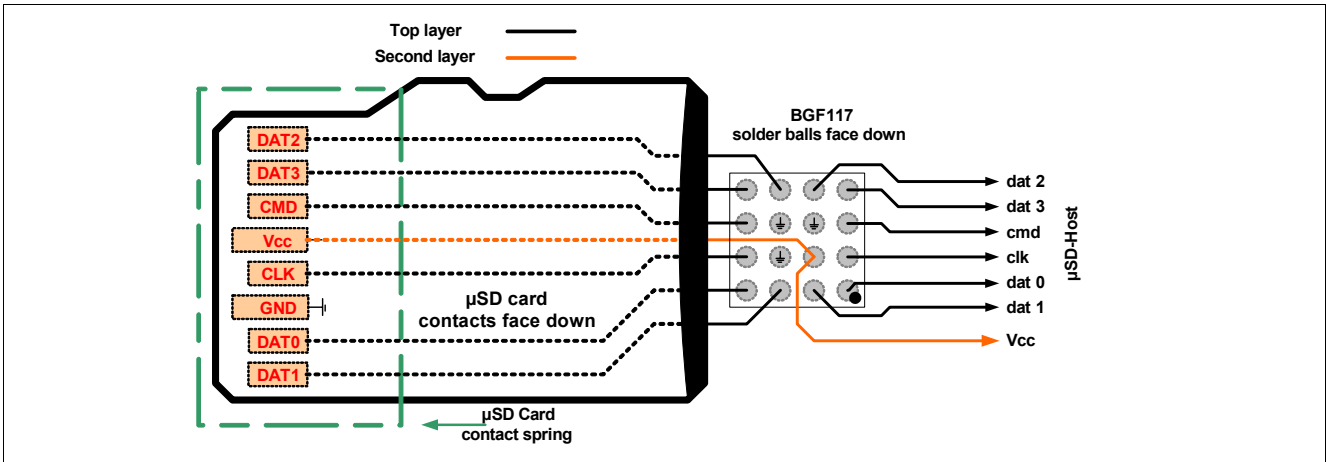

Figure 4 Application example with signal routing

Pull-up resistors for the data and command lines are integrated in BGF117 (R7 to R11) to prevent bus floating in case no card is inserted or all card drivers are in high impedance mode.

Package outline

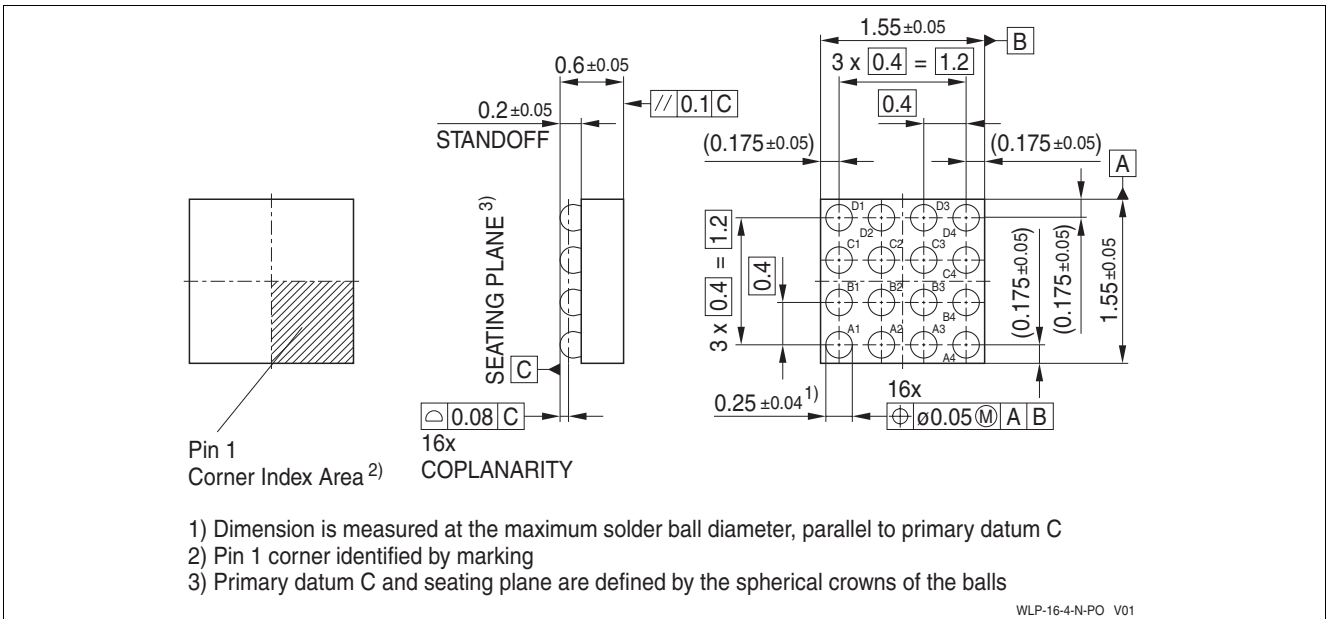

Figure 5 Package outline for WLP-16-4 (dimensions in mm)

Footprint

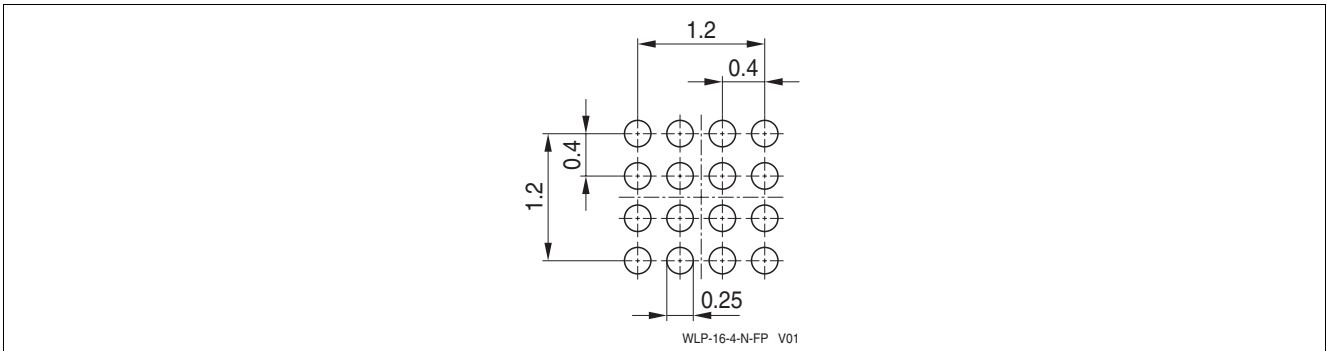

Figure 6 Recommended PCB pad design for reflow soldering (dimensions in mm)

Tape

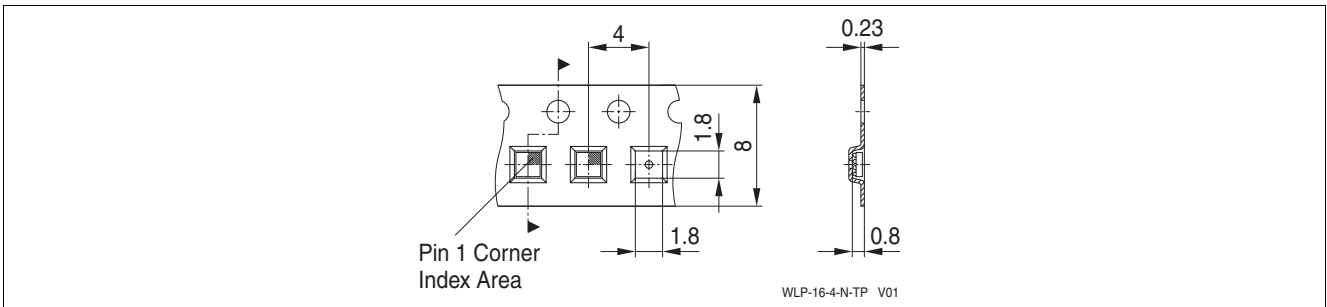



Figure 7 Tape for BGF117 / WLP-16-4 (dimensions in mm)

Looking for pricing, stock, or lifecycle information?

Click below to explore more details on WIN SOURCE:

-  [View BGF117 E6328 on WIN SOURCE](#)
-  [Infineon Technologies Information](#)

Optimize Your Supply Chain with WIN SOURCE Solutions

-  Global Sourcing Solution
-  Obsolete Management
-  Cost Control Management
-  Shortage Management
-  Alternative Solution
-  Excess Inventory Management