



# THE DATASHEET OF BGF100



# BGF100

## Microphone Filter and ESD Protection Evaluation Kit

RF & Protection Devices



Never stop thinking

**Edition 2007-02-21**

**Published by  
Infineon Technologies AG  
81726 München, Germany**

**© Infineon Technologies AG 2009.  
All Rights Reserved.**

#### **LEGAL DISCLAIMER**

THE INFORMATION GIVEN IN THIS APPLICATION NOTE IS GIVEN AS A HINT FOR THE IMPLEMENTATION OF THE INFINEON TECHNOLOGIES COMPONENT ONLY AND SHALL NOT BE REGARDED AS ANY DESCRIPTION OR WARRANTY OF A CERTAIN FUNCTIONALITY, CONDITION OR QUALITY OF THE INFINEON TECHNOLOGIES COMPONENT. THE RECIPIENT OF THIS APPLICATION NOTE MUST VERIFY ANY FUNCTION DESCRIBED HEREIN IN THE REAL APPLICATION. INFINEON TECHNOLOGIES HEREBY DISCLAIMS ANY AND ALL WARRANTIES AND LIABILITIES OF ANY KIND (INCLUDING WITHOUT LIMITATION WARRANTIES OF NON-INFRINGEMENT OF INTELLECTUAL PROPERTY RIGHTS OF ANY THIRD PARTY) WITH RESPECT TO ANY AND ALL INFORMATION GIVEN IN THIS APPLICATION NOTE.

#### **Information**

For further information on technology, delivery terms and conditions and prices please contact your nearest Infineon Technologies Office ([www.infineon.com](http://www.infineon.com)).

#### **Warnings**

Due to technical requirements components may contain dangerous substances. For information on the types in question please contact your nearest Infineon Technologies Office.

Infineon Technologies Components may only be used in life-support devices or systems with the express written approval of Infineon Technologies, if a failure of such components can reasonably be expected to cause the failure of that life-support device or system, or to affect the safety or effectiveness of that device or system. Life support devices or systems are intended to be implanted in the human body, or to support and/or maintain and sustain and/or protect human life. If they fail, it is reasonable to assume that the health of the user or other persons may be endangered.

---

**Microphone Filter and ESD Protection Evaluation Kit**

**Revision History: 2007-02-21, Rev. 1.2**

**Previous Version: 2006-02.13, Rev. 1.1**

<b>Page</b>	<b>Subjects (major changes since last revision)</b>
1	Titel change

# 1 BGF100 Microphone Filter and ESD Protection Evaluation Kit

## 1.1 Description

The BGF100 is a microphone filter with low pass characteristic offering a very high stop band attenuation up to 6 GHz. It also provides an ESD protection at the input pins up to 15 kV contact discharge. The wafer level package is a green lead free package with a size of only 1.6 mm x 2.1 mm and a total height of 0.65 mm.

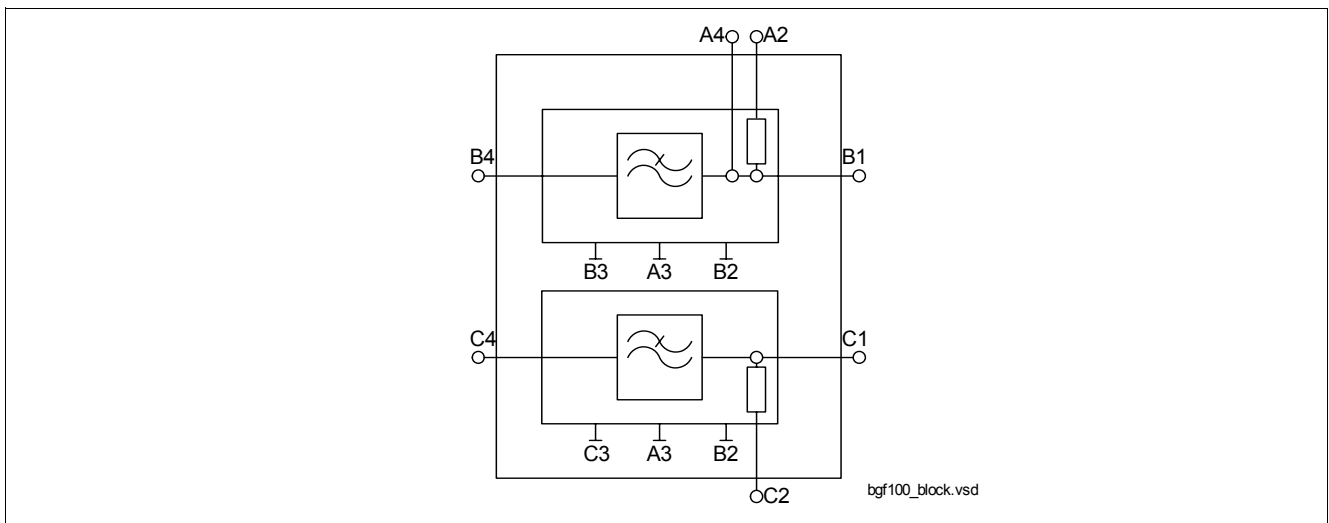

Figure 1 Block Diagram

The evaluation kit for the BGF100 microphone filter and ESD protection IC consists of two printed circuit boards:

- DC board
- RF board

## 1.2 DC Board

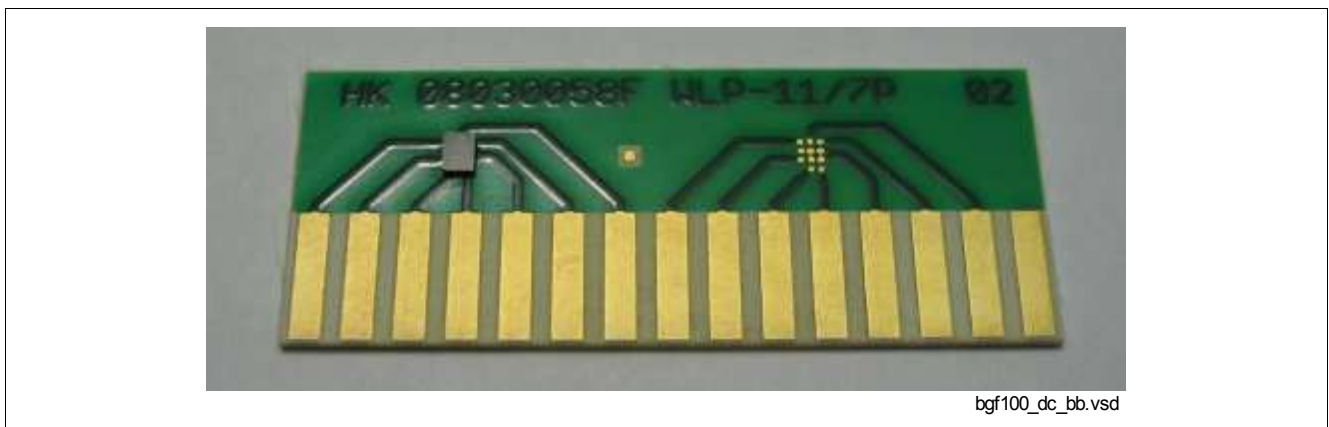

Figure 2 DC evaluation board

**BGF100 Microphone Filter and ESD Protection Evaluation Kit**

**Figure 2** shows the DC evaluation board used in this evaluation kit. This PCB was designed to be mounted with two BGF100. On the left hand side the HiPAC IC is soldered to the board while the right hand side of the board was left open to show the footprint required for BGF100.

The size of the board is 15 mm by 38 mm. The pitch size of the pads is 2.54 mm.

This board was designed to perform pin-to-pin DC tests, like measuring the values of the integrated resistors, as well as checking the ESD performance of the IC. It can also be used for qualification purposes.

**1.3 RF Board**

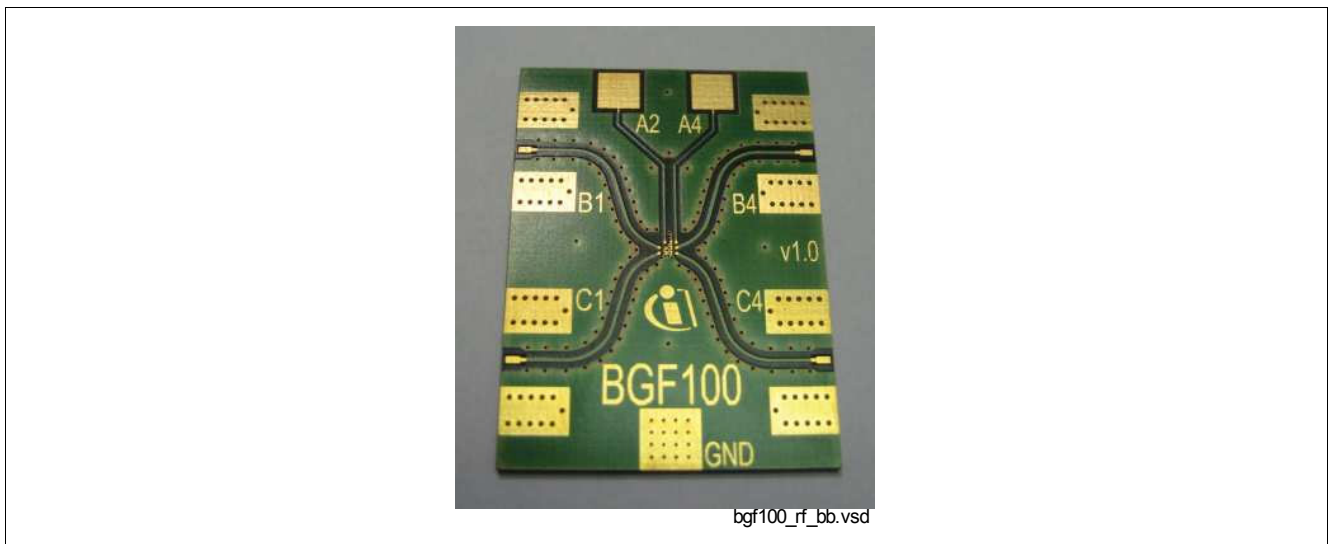

**Figure 3 Bare RF Board**



**Figure 4 Populated RF Board**

**BGF100 Microphone Filter and ESD Protection Evaluation Kit**

**Figure 3** shows an unpopulated RF board for testing BGF100. It offers the possibility to measure the RF performance of the two signal lines B4-B1 and C4-C1. Additional DC pads on the board give access to pins A1 and A4 as well as to the GND pins. Please note that pin C2 is grounded.

**Figure 4** shows a fully assembled RF board. The size of this board is 28 mm by 38 mm, not including the SMA connectors.

**1.3.1 RF Measurement Curves**

**Figure 5** shows the RF performance of the BGF100, it was measured in a 50 Ω system. The typical transmission characteristics of both signal lines are displayed, B1-B4 in blue and C4-C1 in magenta.

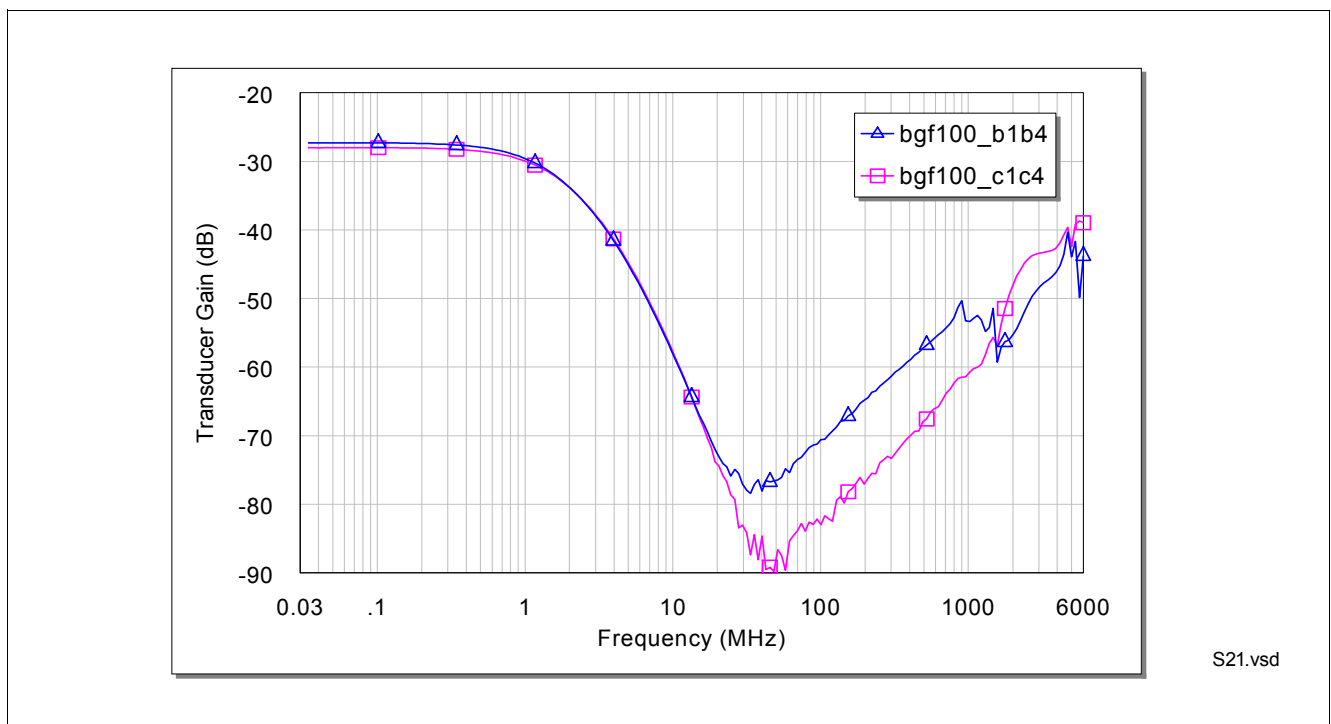

Please note that the difference between the two curves is due to the fact that the resistor between C1 and C2 on signal line C4-C1 is connected to ground while its equivalent on line B4-B1 is left open.



**Figure 5 RF Performance of the BGF100**

## Looking for pricing, stock, or lifecycle information?

Click below to explore more details on WIN SOURCE:

-  [View BGF100 on WIN SOURCE](#)
-  [Infineon Technologies Information](#)

## Optimize Your Supply Chain with WIN SOURCE Solutions

-  Global Sourcing Solution
-  Obsolete Management
-  Cost Control Management
-  Shortage Management
-  Alternative Solution
-  Excess Inventory Management