



**THE DATASHEET OF
BGA615L7E6327XTSA1**



BGA615L7

Silicon Germanium GPS Low Noise Amplifier

RF & Protection Devices



Never stop thinking

Edition 2007-02-12

**Published by
Infineon Technologies AG
81726 München, Germany**

**© Infineon Technologies AG 2009.
All Rights Reserved.**

Legal Disclaimer

The information given in this document shall in no event be regarded as a guarantee of conditions or characteristics ("Beschaffenhheitsgarantie"). With respect to any examples or hints given herein, any typical values stated herein and/or any information regarding the application of the device, Infineon Technologies hereby disclaims any and all warranties and liabilities of any kind, including without limitation warranties of non-infringement of intellectual property rights of any third party.

Information

For further information on technology, delivery terms and conditions and prices please contact your nearest Infineon Technologies Office (www.infineon.com).

Warnings

Due to technical requirements components may contain dangerous substances. For information on the types in question please contact your nearest Infineon Technologies Office.

Infineon Technologies Components may only be used in life-support devices or systems with the express written approval of Infineon Technologies, if a failure of such components can reasonably be expected to cause the failure of that life-support device or system, or to affect the safety or effectiveness of that device or system. Life support devices or systems are intended to be implanted in the human body, or to support and/or maintain and sustain and/or protect human life. If they fail, it is reasonable to assume that the health of the user or other persons may be endangered.

BGA615L7**Revision History: 2007-02-12, Rev.1.3****Previous Version: BGA615L7 V1.2**

Page	Subjects (major changes since last revision)
4	added moisture sensitivity level
5	added thermal resistance
6	adjusted power gain settling times adjusted inband and out of band compression points
12	updated recommended land pattern (added solder mask defined layout)
13	added reel diameter and pcs / reel information

Silicon Germanium GPS Low Noise Amplifier

Features

- High gain: 18 dB
- Low Noise Figure: 0.9 dB
- Power off function
- Operating frequency 1575 MHz
- Supply voltage: 2.4 V to 3.2 V
- Tiny PG-TSLP-7-1 leadless package
- B7HF Silicon Germanium technology
- RF output internally matched to 50 Ω
- Low external component count
- 1 kV HBM ESD protection (including AI-pin)
- Moisture sensitivity level: MSL 1

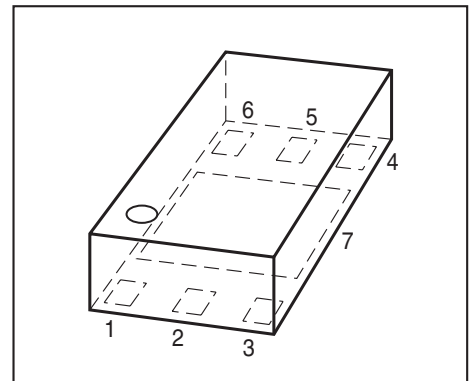

TSLP-7-1

Application

- 1575 MHz GPS

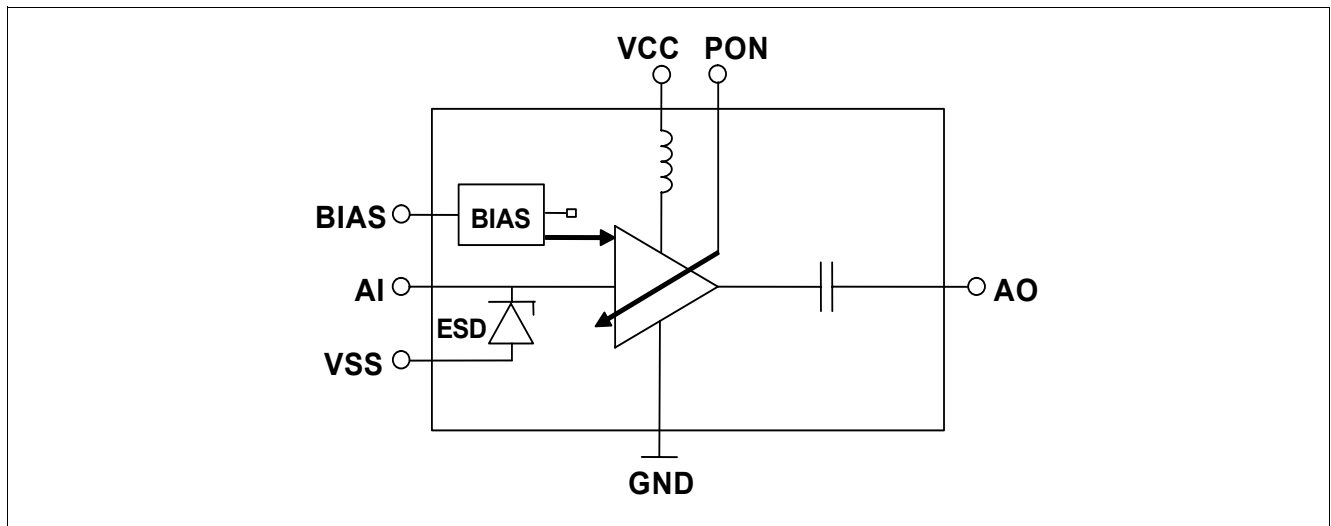

Figure 1 Blockdiagram

Description

The BGA615L7 is a front-end low noise amplifier for Global Positioning System (GPS) applications. The LNA provides 18 dB gain, 0.9 dB noise figure and high linearity performance, allowing it to be used as a first-stage LNA. Current consumption is as low as 5.6 mA. The BGA615L7 is based upon Infineon Technologies' B7HF Silicon Germanium technology. It operates over a 2.4 V to 3.2 V supply range.

Type	Package	Marking	Chip
BGA615L7	PG-TSLP-7-1	BS	T0595

Pin Definition and Function
Table 1 Pin Definition and Function

Pin No.	Symbol	Function
1	AI	LNA input
2	BIAS	DC bias
3	GND	RF ground
4	PON	Power on control
5	VCC	Supply control
6	AO	LNA output
7	VSS	DC ground

Maximum Ratings
Table 2 Maximum Ratings

Parameter ¹⁾	Symbol	Value	Unit
Voltage at pin VCC	V_{CC}	-0.3 ... 3.6	V
Voltage at pin AI	V_{AI}	-0.3 ... 0.9	V
Voltage at pin BIAS	V_{BIAS}	-0.3 ... 0.9	V
Voltage at pin AO	V_{AO}	-0.3 ... $V_{CC} + 0.3$	V
Voltage at pin PON	V_{PON}	-0.3 ... $V_{CC} + 0.3$	V
Voltage at pin VSS	V_{SS}	-0.3 ... 0.3	V
Current into pin VCC	I_{CC}	10	mA
RF input power	P_{IN}	10	dBm
Total power dissipation	P_{tot}	36	mW
Junction temperature	T_J	150	°C
Ambient temperature range	T_A	-30 ... 85	°C
Storage temperature range	T_{STG}	-65 ... 150	°C
Thermal resistance junction soldering point	$R_{th JS}$	240	K/W
ESD capability all pins (HBM: JESD22A-114)	V_{ESD}	1000	V

1) All voltages refer to GND-Node.

Electrical Characteristics
Table 3 Electrical Characteristics¹⁾: $T_A = 25\text{ °C}$, $V_{CC} = 2.8\text{ V}$, $V_{PON,ON} = 2.8\text{ V}$, $V_{PON,OFF} = 0\text{ V}$, $f = 1575\text{ MHz}$

Parameter	Symbol	Values			Unit	Note / Test Condition
		Min.	Typ.	Max.		
Supply voltage	V_{CC}	2.4	2.8	3.2	V	
Supply current	I_{CC}	-	5.6	-	mA	ON-mode
		-	0.2	3	μA	OFF-mode
Gain switch control voltage	V_{pon}	1.5	-	3.2	V	ON-mode
		0	-	0.5	V	OFF-mode
Gain switch control current	I_{pon}	-	1.5	3	μA	ON-mode
		-	0	1	μA	OFF-mode
Insertion power gain	$ S_{21} ^2$	-	18	-	dB	High-gain Mode
Noise figure ²⁾	NF	-	0.9	-	dB	$Z_S = 50\ \Omega$
Input return loss	RL_{in}	-	13	-	dB	
Output return loss	RL_{out}	-	>15	-	dB	
Reverse isolation	$1/ S_{12} ^2$	-	35	-	dB	
Power gain settling time ³⁾	t_S	-	20	-	μs	OFF- to ON-mode
		-	50	-	μs	ON- to OFF-mode
Inband input 3rd order intercept point	IIP_3	-	-1	-	dBm	$f_1 = 1575\text{ MHz}$ $f_2 = f_1 \pm 1\text{ MHz}$
Inband input 1 dB compression point	IP_{1dB}	-	-14	-	dBm	
Out of band input 1 dB compression point	$IP_{1dB,900M}$	-	-9	-	dBm	$f = 806\text{ MHz} \dots 928\text{ MHz}$
Out of band input 1 dB compression point	$IP_{1dB,1650M}$	-	-12	-	dBm	$f = 1612\text{ MHz} \dots 1710\text{ MHz}$
Out of band input 1 dB compression point	$IP_{1dB,1900M}$	-	-6	-	dBm	$f = 1710\text{ MHz} \dots 1785\text{ MHz}$ $f = 1850\text{ MHz} \dots 1909\text{ MHz}$
Stability	k	-	> 1.5	-		$f = 20\text{ MHz} \dots 10\text{ GHz}$

1) Measured on BGA615L7 application board including PCB losses (unless noted otherwise)

2) PCB losses subtracted

3) To within 1 dB of the final gain OFF- to ON-mode; to within 3 dB of the final gain ON- to OFF-mode

Typical Measurement Results ON Mode; $T_A = 25\text{ }^\circ\text{C}$

Gain $|S_{21}|^2 = f(f)$
 $V_{CC} = 2.8\text{ V}$

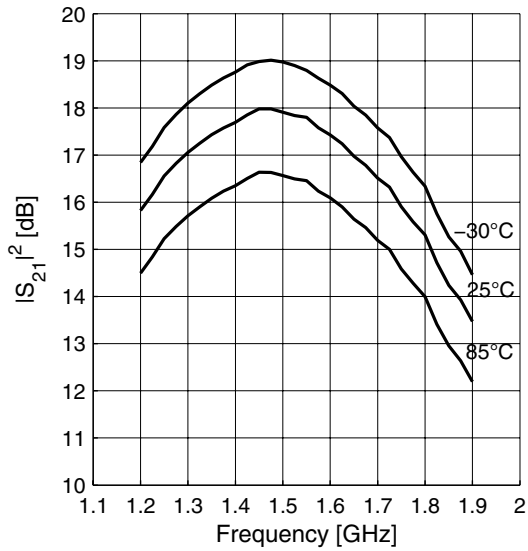

Noise Figure¹⁾ $NF = f(f)$
 $V_{CC} = 2.8\text{ V}$

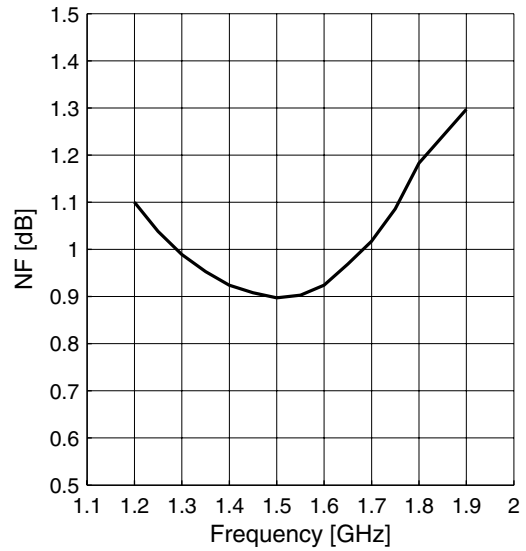

Reverse Isolation $1/|S_{12}|^2 = f(f)$
 $V_{CC} = 2.8\text{ V}$

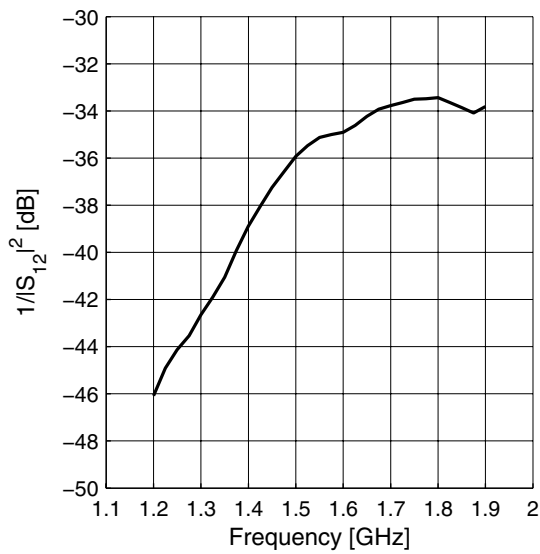

Matching $|S_{11}|, |S_{22}| = f(f)$
 $V_{CC} = 2.8\text{ V}$

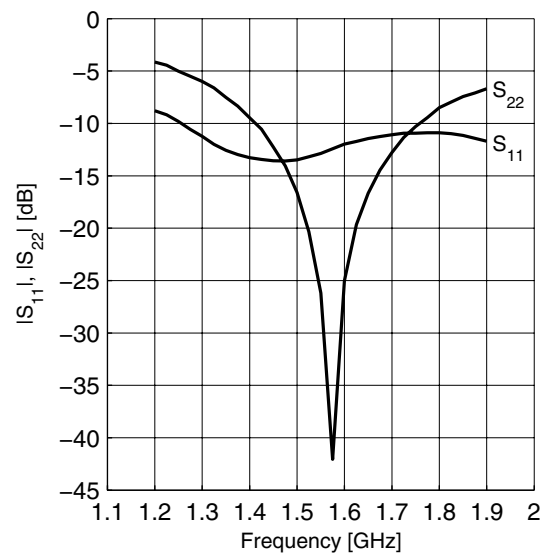

1) PCB losses subtracted

Typical Measurement Results ON Mode vs. Temperature

Power Gain $|S_{21}|^2 = f(T_A)$
 $V_{CC} = 2.8\text{ V}$

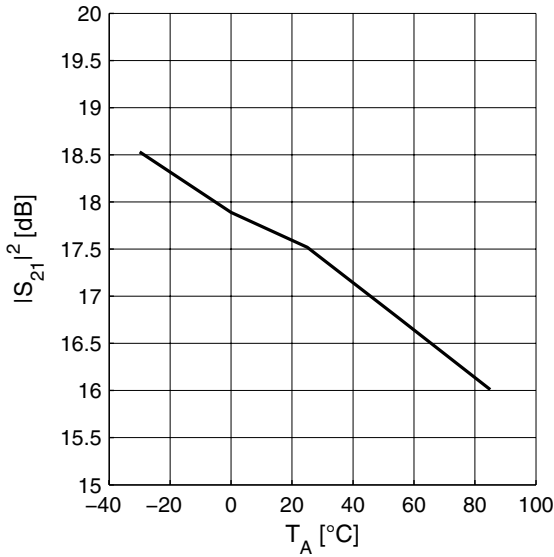

Noise Figure¹⁾ $NF = f(T_A)$
 $V_{CC} = 2.8\text{ V}$

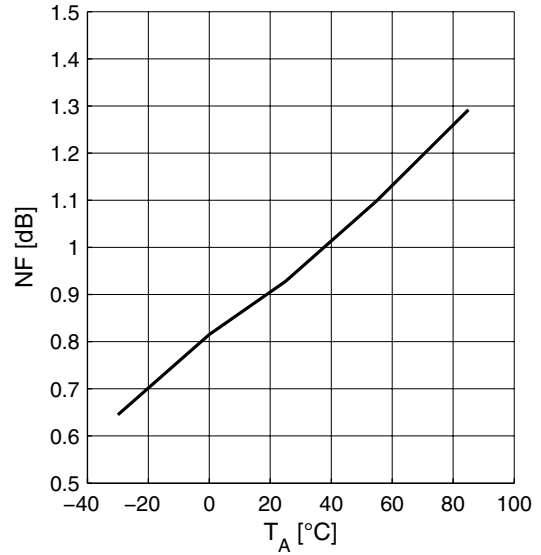

Supply current $I_{CC} = f(T_A)$
 $V_{CC} = 2.8\text{ V}$

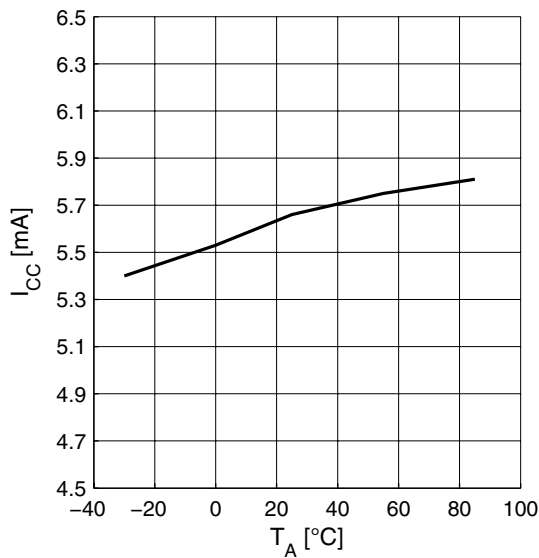

Third Order Input Intercept Point $IIP_3 = f(T_A)$
 $V_{CC} = 2.8\text{ V}$

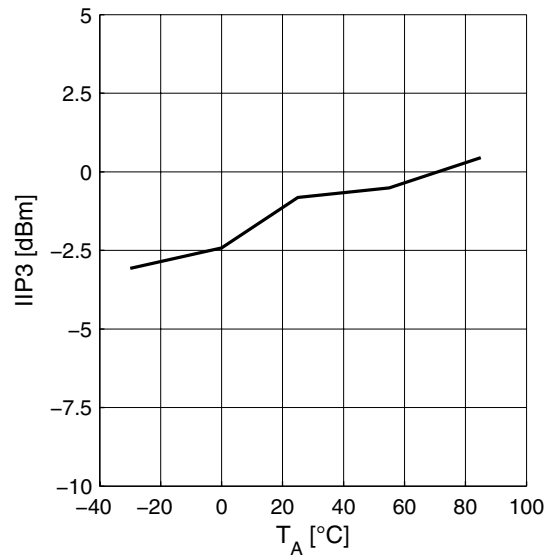

1) PCB losses subtracted

Typical Measurement Results ON Mode vs. Supply Voltage

Power Gain $|S_{21}| = f(V_{CC})$
 $T_A = 25\text{ }^\circ\text{C}$

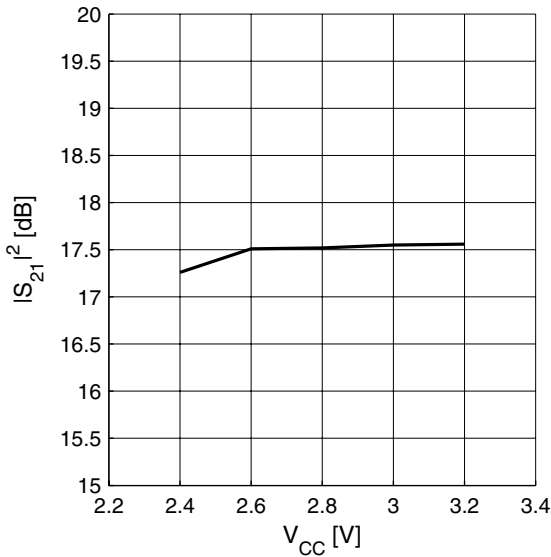

Noise Figure¹⁾ $NF = f(V_{CC})$
 $T_A = 25\text{ }^\circ\text{C}$

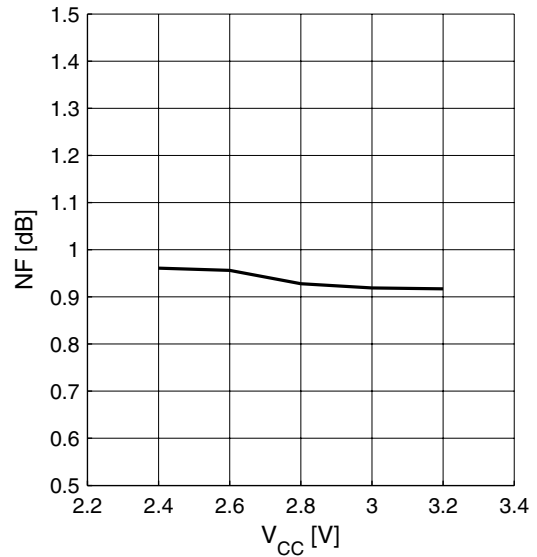

Supply current $I_{CC} = f(V_{CC})$
 $T_A = 25\text{ }^\circ\text{C}$

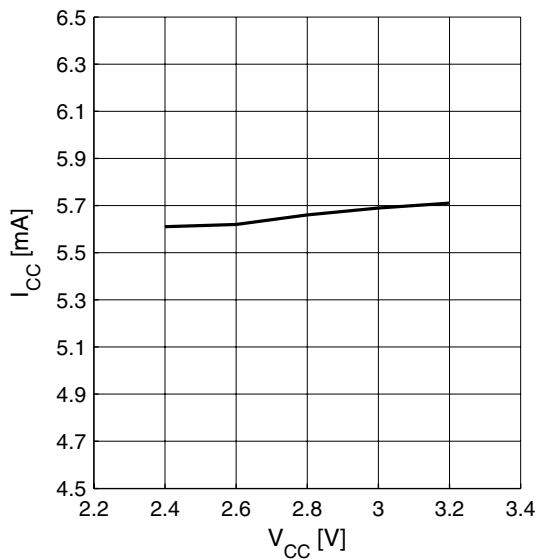

Third Order Input Intercept Point $IIP_3 = f(V_{CC})$
 $T_A = 25\text{ }^\circ\text{C}$

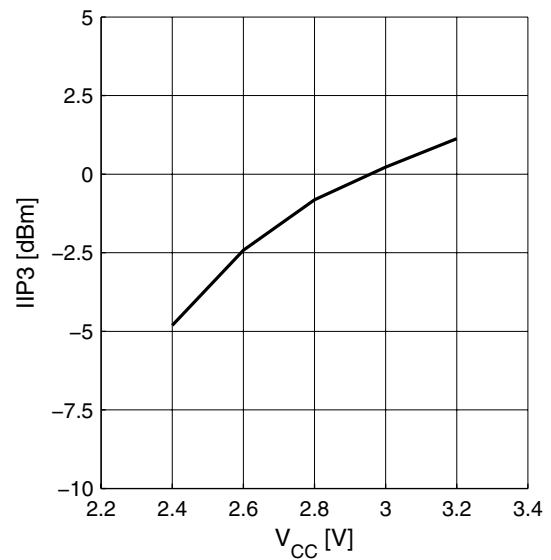

1) PCB losses subtracted

PCB Configuration

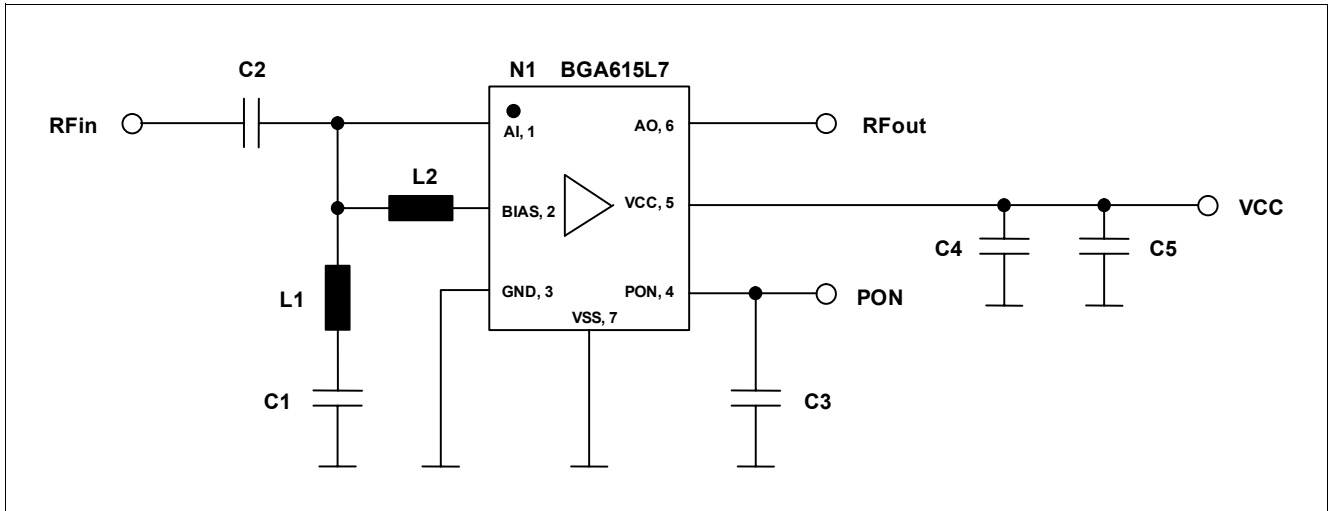

Figure 2 Schematic of BGA615L7

Table 4 Bill of Materials

Name	Value	Package	Manufacturer	Function
C1	10 nF	0402	Various	LF trap
C2	5 pF	0402	Various	DC block
C3	10 pF	0402	Various	Control voltage filtering optional
C4	100 pF	0402	Various	Supply filtering optional
C5	2.2 nF	0402	Various	Supply filtering
L1	3.3 nH	0402	Various	LF trap & input matching
L2	100 nH	0402	Various	Biasing
N1	BGA615L7	PG-TSLP-7-1	Infineon	SiGe LNA

Application Board

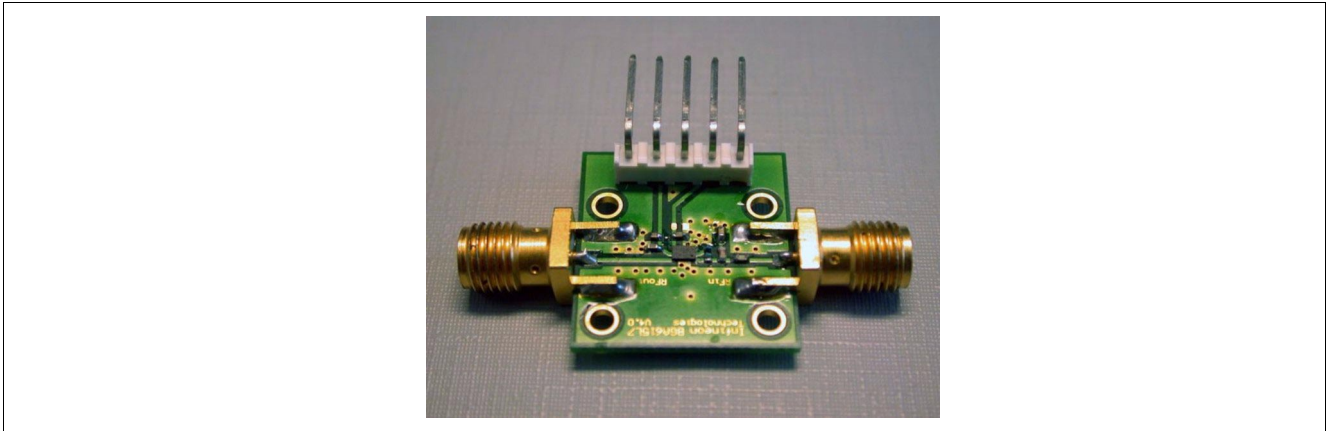

Figure 3 Photograph of Application Board

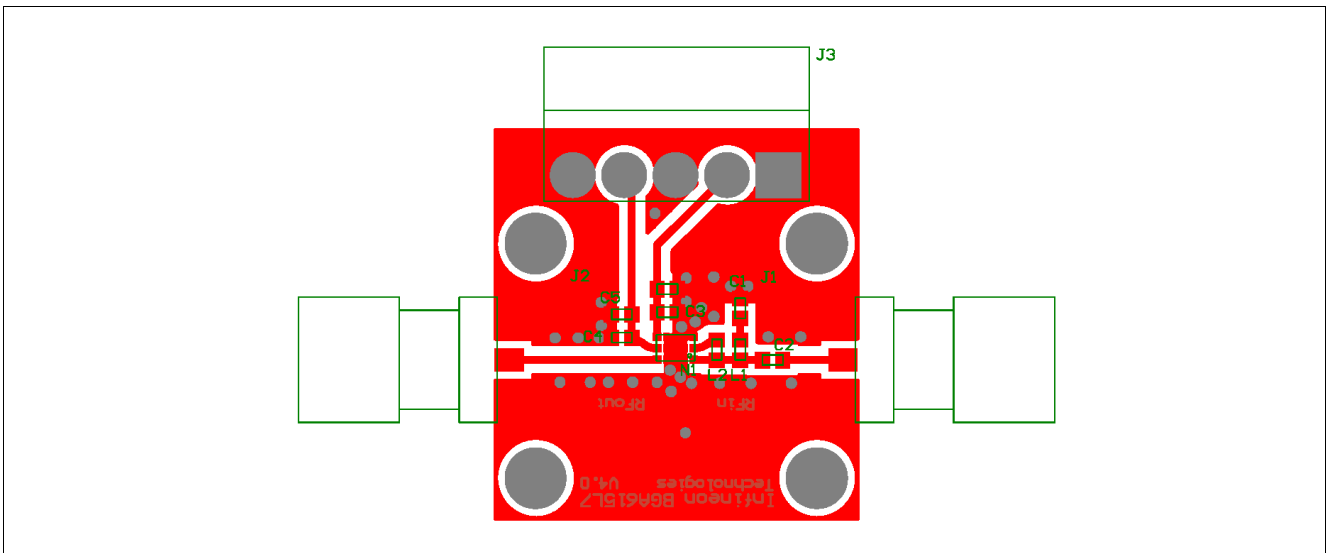

Figure 4 Top View of Application Board

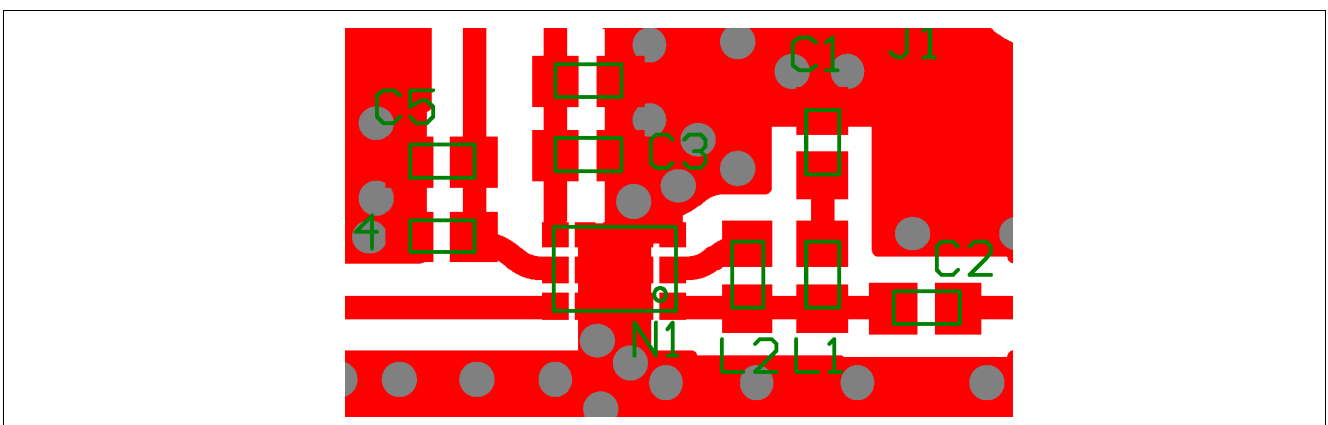

Figure 5 Detailed View of Application Board

Please note that RF-ground is connected via pin 3 only. In order to achieve the same performance as given in this data sheet, it is necessary to provide good RF-grounding on this pin. Furthermore, the LF trap consisting of inductor L1 and capacitor C1 should be placed as close as possible to pin 3.

Silicon Germanium GPS Low Noise Amplifier

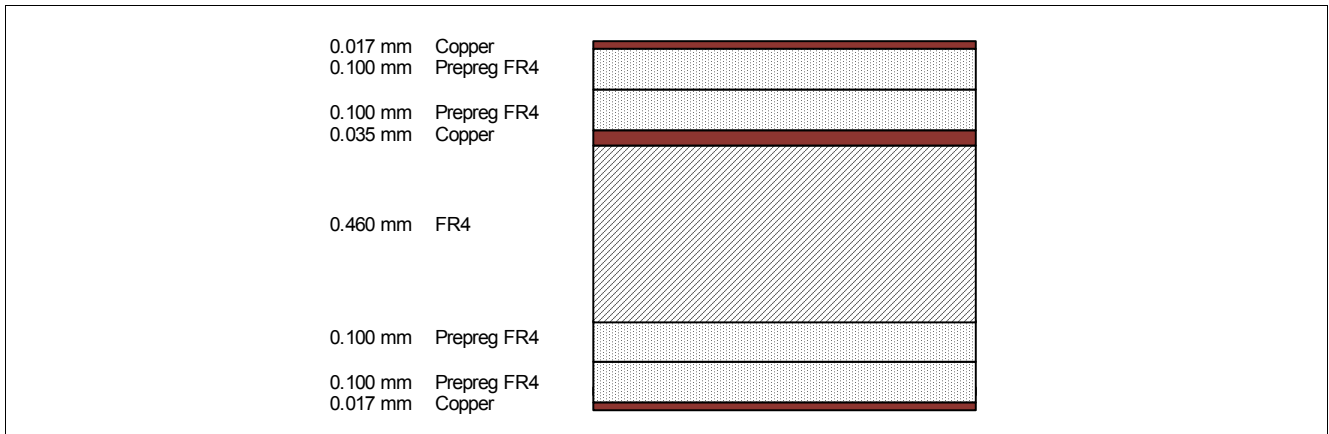

Figure 6 Cross-Section View of Application Board

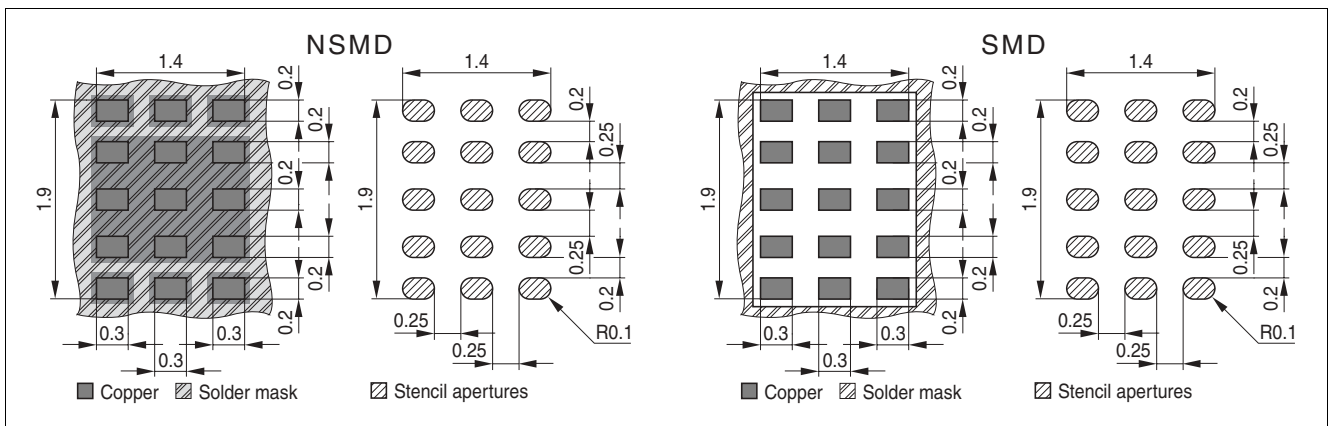

Figure 7 Recommended Land Pattern

Table 5 Application Notes

No.	Description
AN091	The BGA615L7 Silicon-Germanium Low Noise Amplifier in GPS Applications
AN093	The BGA615L7 Silicon-Germanium Low Noise Amplifier with 0201 chip components
AN094	The BGA615L7 Silicon-Germanium Low Noise Amplifier for Low-Current GPS Applications

A list of all application notes is available at <http://goto.infineon.com/smallsignaldiscretes-appnotes>.

Package Information

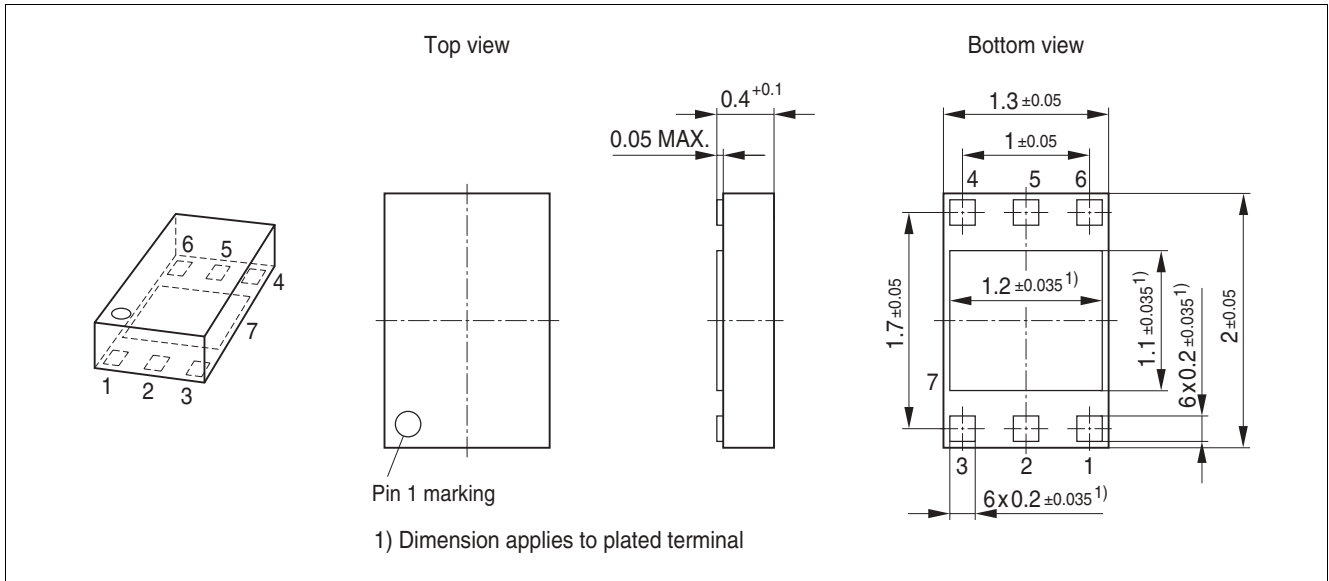

Figure 8 Package Dimensions

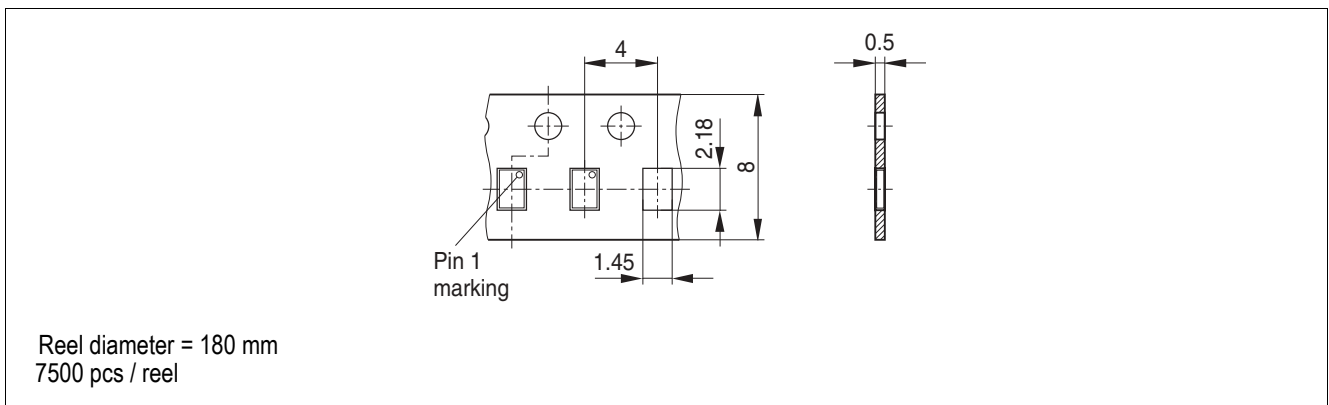

Figure 9 Tape & Reel Dimensions

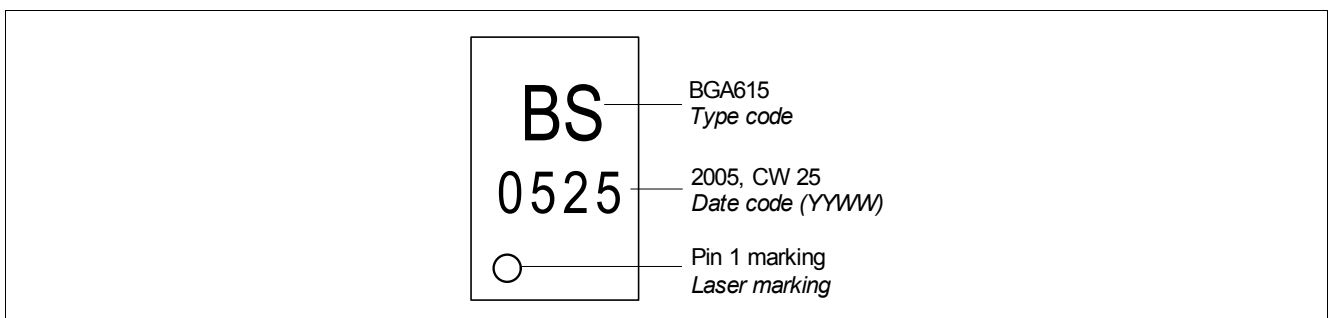



Figure 10 Marking Layout

Looking for pricing, stock, or lifecycle information?

Click below to explore more details on WIN SOURCE:

-  [View BGA615L7E6327XTSA1 on WIN SOURCE](#)
-  [Infineon Technologies Information](#)

Optimize Your Supply Chain with WIN SOURCE Solutions

-  Global Sourcing Solution
-  Obsolete Management
-  Cost Control Management
-  Shortage Management
-  Alternative Solution
-  Excess Inventory Management