



**THE DATASHEET OF
BGA428H6327XTSA1**



BGA428

Gain and PCS Low Noise Amplifier

RF & Protection Devices



Edition 2011-09-02

**Published by Infineon Technologies AG,
81726 München, Germany**

**© Infineon Technologies AG 2011.
All Rights Reserved.**

Attention please!

The information herein is given to describe certain components and shall not be considered as a guarantee of characteristics.

Terms of delivery and rights to technical change reserved.

We hereby disclaim any and all warranties, including but not limited to warranties of non-infringement, regarding circuits, descriptions and charts stated herein.

Information

For further information on technology, delivery terms and conditions and prices please contact your nearest Infineon Technologies Office (www.infineon.com).

Warnings

Due to technical requirements components may contain dangerous substances. For information on the types in question please contact your nearest Infineon Technologies Office.

Infineon Technologies Components may only be used in life-support devices or systems with the express written approval of Infineon Technologies, if a failure of such components can reasonably be expected to cause the failure of that life-support device or system, or to affect the safety or effectiveness of that device or system. Life support devices or systems are intended to be implanted in the human body, or to support and/or maintain and sustain and/or protect human life. If they fail, it is reasonable to assume that the health of the user or other persons may be endangered.

BGA428, Gain and PCS Low Noise Amplifier

Revision History: 2011-09-02, Rev. 2.3

Previous Version: 2007-11-06, Rev. 2.3

Page	Subjects (major changes since last revision)
6	Correction of typing error in Table 3 , (IIP_3 is -9 dBm)

Trademarks

SIEGET[®] is a registered trademark of Infineon Technologies AG.

1 Silicon Germanium Broadband MMIC Amplifier

Feature

- High gain, $G_{MA} = 20$ dB at 1.8 GHz
- Low noise figure, $NF = 1.4$ dB at 1.8 GHz
- Prematched
- Ideal for GSM, DCS1800, PCS1900
- Open collector output
- Typical supply voltage: 2.4 - 3 V
- SIEGET[®]-45 technology
- Pb-free (RoHS compliant) package

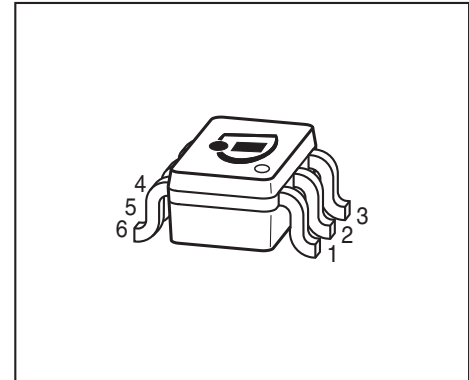

SOT363

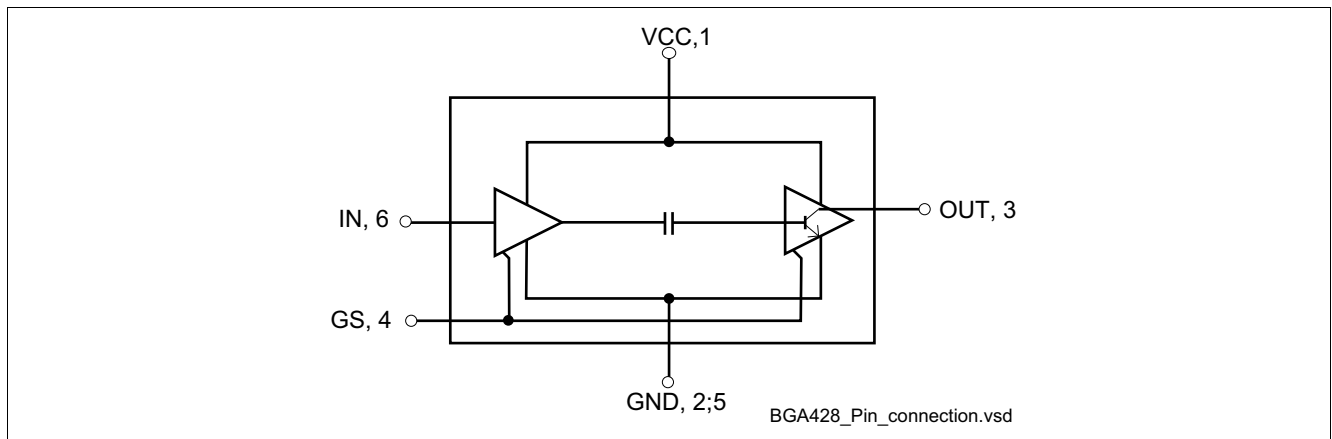

Figure 1 Pin connection

Description

BGA428 is a high gain, low noise amplifier.

Type	Package	Marking
BGA428	SOT363	PGs

Note: **ESD**: Electrostatic discharge sensitive device, observe handling precaution

Maximum Ratings
Table 1 Maximum ratings

Parameter	Symbol	Limit Value	Unit
Device voltage	V_{CC}	4	V
Voltage at pin Out	V_{out}	4	V
Voltage at pin GS	V_{GS}	3.5	V
Current into pin In	I_{in}	0.5	mA
Total device current ¹⁾	I_{tot}	12	mA
Input power ²⁾	P_{in}	8	dBm
Total power dissipation, $T_S < 125\text{ °C}$ ³⁾	P_{tot}	50	mW
Junction temperature	T_J	150	°C
Operating temperature range	T_{OP}	-40... 85	°C
Storage temperature range	T_{STG}	-65... 150	°C

1) I_{tot} = Current into Out + Current into V_{CC}

2) Valid for:

a) $Z_L = 50\ \Omega$, $Z_S = 50\ \Omega$, $V_{CC} = 2.7\text{ V}$, $V_{out} = 2.7\text{ V}$, $V_{GS} = 0.0\text{ V}$, $GND = 0.0\text{ V}$

b) $Z_L = 50\ \Omega$, $Z_S = 50\ \Omega$, $V_{CC} = 0.0\text{ V}$, $V_{out} = 0.0\text{ V}$, $V_{GS} = 2.7\text{ V}$, $GND = 0.0\text{ V}$

3) T_S is measured on the ground lead at the soldering point

Note: All Voltages refer to GND-Node

Thermal resistance
Table 2 Thermal resistance

Parameter	Symbol	Value	Unit
Junction - soldering point ¹⁾	R_{thJS}	220	K/W

1) For calculation of R_{thJA} please refer to Application Note Thermal Resistance

2 Electrical Characteristics

2.1 Electrical characteristics at $T_A = 25\text{ }^\circ\text{C}$ (measured in test circuit specified in **Figure 2**), $V_{CC} = 2.7\text{ V}$, Frequency = 1.8 GHz, unless otherwise specified

Table 3 Electrical Characteristics

Parameter	Symbol	Values			Unit	Note / Test Condition
		Min.	Typ.	Max.		
Maximum available power gain	G_{MA}		20		dB	
Noise figure ($Z_S = 50\ \Omega$)	NF		1.4		dB	
Input power at 1 dB gain compression	P_{-1dB}		-19		dBm	
Input third order intercept point	IIP_3		-9		dBm	
Total device current	I_{tot}		8.2		mA	
Insertion loss in gain-step-mode	L_{GS}		13.5		dB	$V_{CC} = 0.0\text{ V}$, $V_{CTRL} = 2.7\text{ V}$, $R_{CRRL} = 3\text{ k}\Omega$

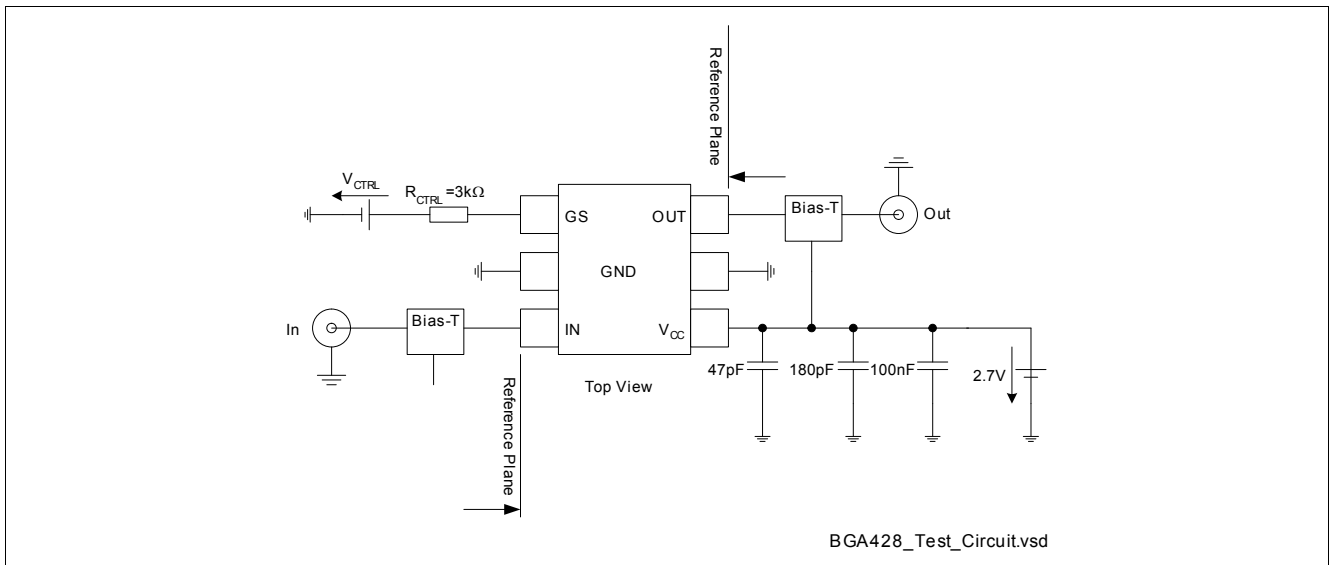

Figure 2 Test Circuit for Electrical Characteristics and S-Parameter

Table 4 S-Parameter at 2.7 V (see Electrical Characteristics for conditions)

Frequency [GHz]	S11 Mag	S11 Ang	S21 Mag	S21 Ang	S12 Mag	S12 Ang	S22 Mag	S22 Ang
0.100	0.6756	-31.7	58.775	-19.6	0.0005	153.5	0.9491	-3.9
0.200	0.5936	-53.6	47.806	-43.1	0.0014	138.4	0.9327	-6.3
0.300	0.5150	-71.4	39.232	-59.5	0.0021	119.0	0.9174	-8.3
0.400	0.4587	-86.6	31.740	-71.8	0.0028	104.9	0.9035	-10.3
0.600	0.4004	-110.7	23.868	-89.6	0.0042	105.9	0.8807	-14.0
0.800	0.3743	-129.1	18.509	-103.2	0.0063	94.3	0.8593	-17.7
1.000	0.3743	-143.0	14.825	-114.5	0.0082	92.4	0.8352	-21.4
1.200	0.3816	-154.5	12.288	-124.7	0.0093	87.2	0.8116	-25.1
1.400	0.3922	-164.4	10.353	-134.2	0.0110	85.3	0.7865	-28.7
1.600	0.4086	-172.4	8.879	-143.2	0.0132	79.4	0.7597	-32.2
1.800	0.4265	-178.9	7.732	-151.4	0.0141	79.4	0.7309	-36.0
1.900	0.4314	-178.8	7.214	-155.2	0.0146	76.1	0.7199	-37.5
2.000	0.4371	176.1	6.771	-159.1	0.0150	77.0	0.7097	-39.1
2.200	0.4505	171.2	5.976	-166.6	0.0169	75.2	0.6791	-42.3
2.400	0.4640	167.2	5.298	-173.5	0.0181	73.2	0.6593	-45.6
3.000	0.4935	155.9	3.935	167.0	0.0217	68.3	0.5925	-53.3
4.000	0.5181	141.2	2.605	139.2	0.0282	65.1	0.5284	-64.9
5.000	0.5202	126.9	1.911	113.6	0.0319	62.2	0.4829	-75.1
6.000	0.5128	110.0	1.479	89.9	0.0489	56.0	0.4323	-81.7

2.2 Application Circuit Characteristics (measured in test circuit specified in Figure 3), $T_A = 25\text{ }^\circ\text{C}$, $V_{CC} = 2.7\text{ V}$, Frequency = 1.85 GHz, unless otherwise specified

Table 5 Application Circuit Characteristics

Parameter	Symbol	Values			Unit	Note / Test Condition
		Min.	Typ.	Max.		
Insertion power gain	$ S_{21} ^2$		19		dB	
Noise figure ($Z_S = 50\ \Omega$)	NF		1.4		dB	
Input power at 1 dB gain compression	P_{-1dB}		-19		dBm	
Input third order intercept point	IIP_3		-9		dBm	
Total device current	I_{tot}		8.2		mA	
Insertion loss in gain-step-mode	L_{GS}		13.5		dB	$V_{CC} = 0.0\text{ V}$, $V_{CTRL} = 2.7\text{ V}$, $R_{CRRL} = 3\text{ k}\Omega$

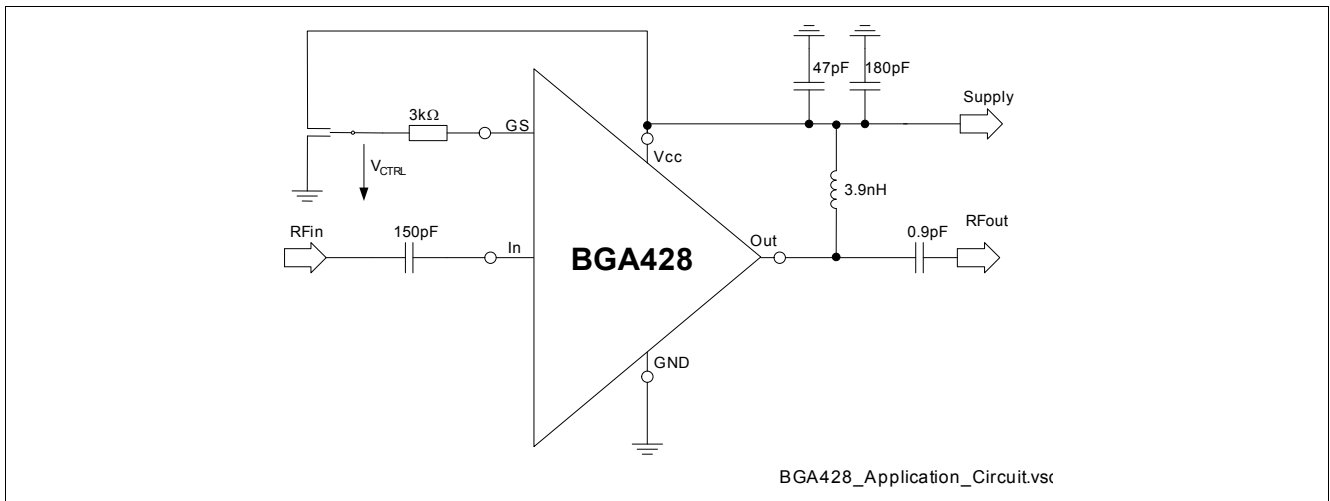
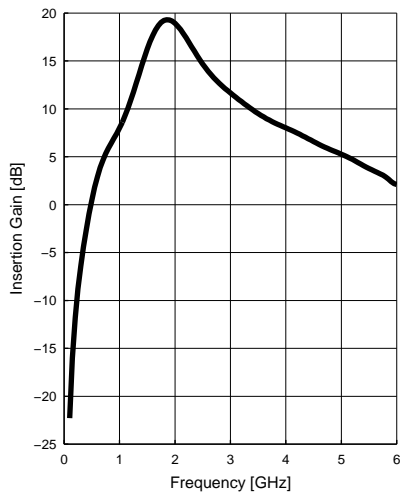

Figure 3 Application Circuit for 1850 MHz

3 Measured Parameters

Refer to the application circuit given in [Figure 3](#)

Power Gain $|S_{21}|^2=f(f)$
 $V_{CC} = 2.7V, V_{Out} = 2.7V$



Power Gain $|S_{21}|^2=f(f)$
 $V_{CC} = 2.7V, V_{Out} = 2.7V$

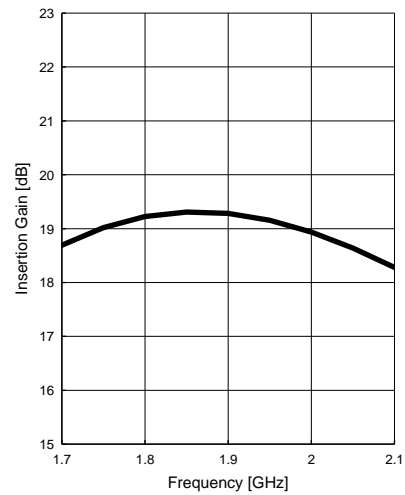

Off-Gain $|S_{21}|^2=f(V_{CTRL})$
 $V_{CC} = 0.0V, V_{Out} = 0.0V, R_{CTRL} = 2.7k\Omega$

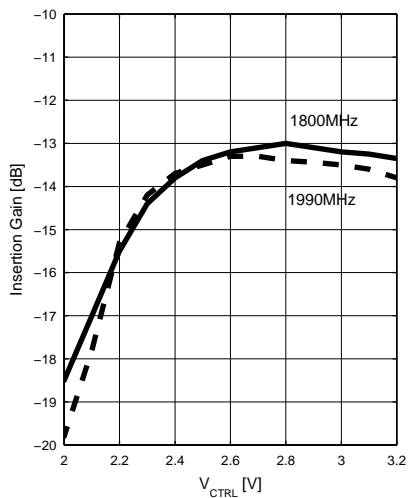

Matching $|S_{11}|, |S_{22}|=f(f)$
 $V_{CC} = 2.7V, V_{Out} = 2.7V$

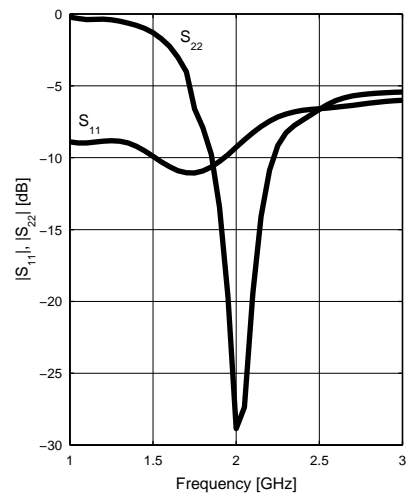

Input Compression Point $P_{-1dB}=f(f)$

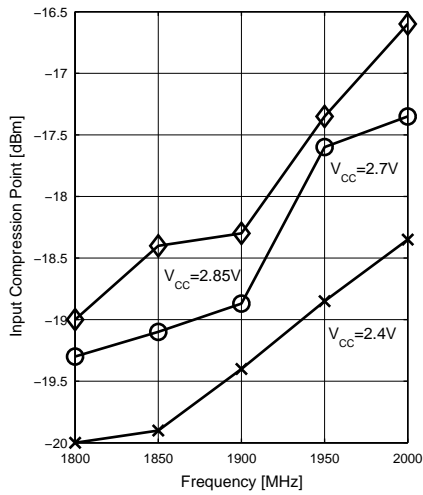

Device Current $I=f(\vartheta)$

$V_{CC}=2.7V, V_{Out}=2.7V$

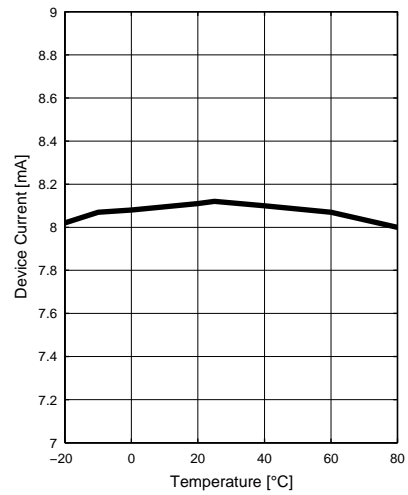

Insertion Gain $|S_{21}|^2=f(\vartheta)$

$V_{CC}=2.7V, V_{Out}=2.7V$

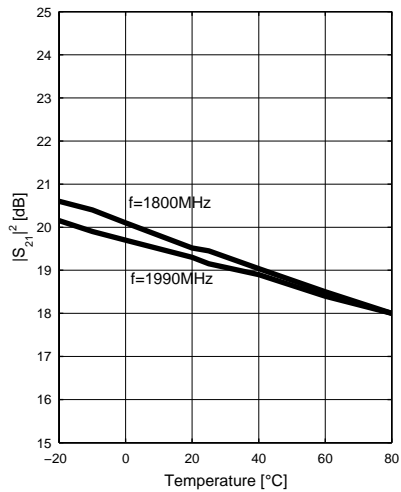

4 Package Information

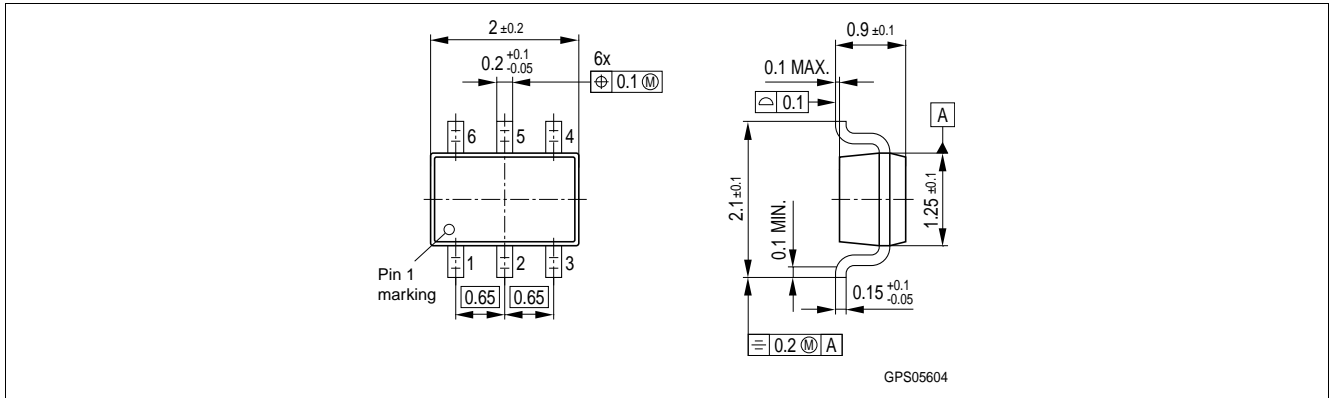

Figure 4 Package Outline SOT363

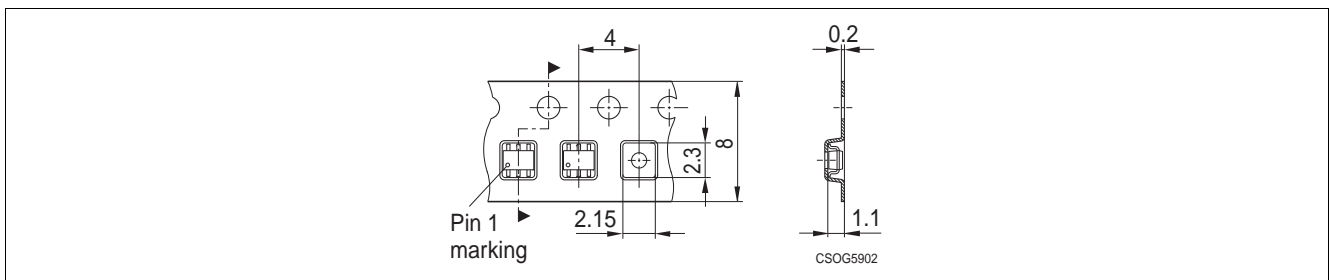



Figure 5 Tape for SOT363

Looking for pricing, stock, or lifecycle information?

Click below to explore more details on WIN SOURCE:

-  [View BGA428H6327XTSA1 on WIN SOURCE](#)
-  [Infineon Technologies Information](#)

Optimize Your Supply Chain with WIN SOURCE Solutions

-  Global Sourcing Solution
-  Obsolete Management
-  Cost Control Management
-  Shortage Management
-  Alternative Solution
-  Excess Inventory Management