



**THE DATASHEET OF  
USB3140-30-0170-1-C**



# PRODUCT SPECIFICATION

<b>Part Number</b>	USB3140	<b>Rev</b>	A1	<b>Date</b>	31/07/17		
<b>Product Description</b>	Micro USB Receptacle, Type B, 5 Pins, SMT, Vertical, with Through-Hole Shell Stakes			<b>Page</b>	1		
<b>Doc Number</b>	USB3140	<b>Prepared</b>	<b>CC</b>	<b>Checked</b>	<b>RM</b>	<b>Approved</b>	<b>VJ</b>

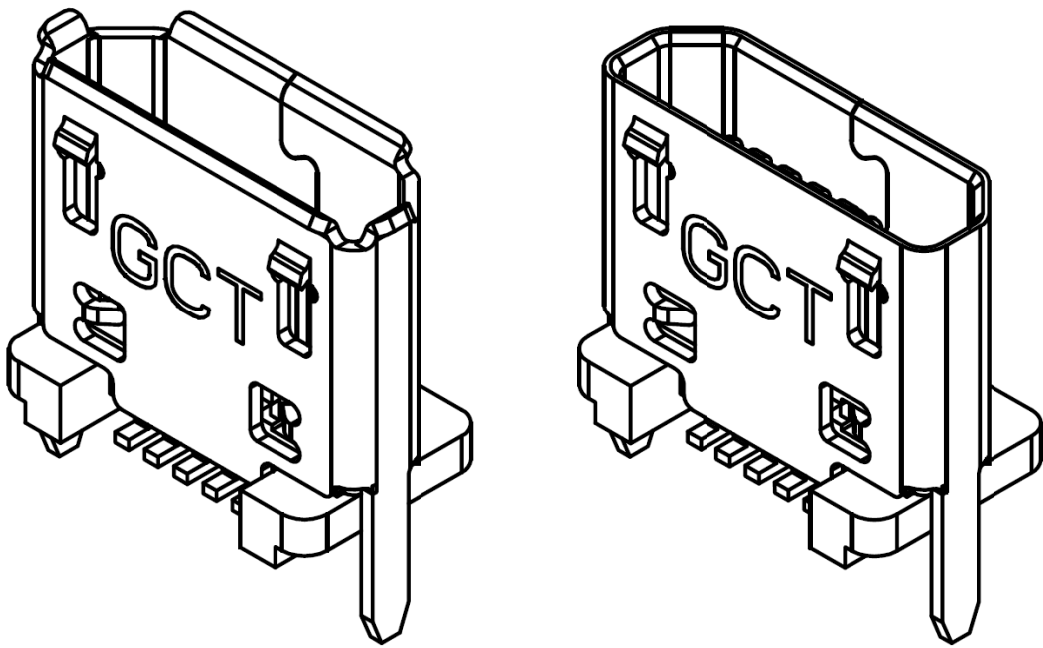

# PRODUCT SPECIFICATION

<b>Part Number</b>	USB3140	<b>Rev</b>	A1	<b>Date</b>	31/07/17		
<b>Product Description</b>	Micro USB Receptacle, Type B, 5 Pins, SMT, Vertical, with Through-Hole Shell Stakes			<b>Page</b>	2		
<b>Doc Number</b>	USB3140	<b>Prepared</b>	<b>CC</b>	<b>Checked</b>	<b>RM</b>	<b>Approved</b>	<b>VJ</b>

## 1.0 SCOPE.

This specification covers performance, tests and quality requirements for the Micro USB Receptacle USB3140(Type B, SMT, Vertical).

## 2.0 PRODUCT NAME AND PART NUMBER.

Micro USB Receptacle, 5 Pins, SMT, Type B: USB3140.

## 3.0 PRODUCT SHAPE, DIMENSIONS AND MATERIAL.

Please refer to drawings.

## 4.0 RATINGS.

4.1 Current rating: Signal (Pins 2, 3, 4)     1.0A

Power (Pins1, 5).....     1.8A

4.2 Voltage rating ..... 30V AC

4.3 Operating Temperature Range .....-30°C to +85°C

## 5.0 TEST AND MEASUREMENT CONDITIONS.

Product is designed to meet electrical, mechanical and environmental performance requirements specified in Paragraph 6.0. All tests are performed in ambient conditions unless otherwise specified.

## 6.0 PERFORMANCE.

Item	Test Condition	Requirement
Examination of Product	Visual, dimensional and functional inspection as per quality plan.	Product shall meet requirements of product drawing and specification.

# PRODUCT SPECIFICATION

<b>Part Number</b>	USB3140	<b>Rev</b>	A1	<b>Date</b>	31/07/17		
<b>Product Description</b>	Micro USB Receptacle, Type B, 5 Pins, SMT, Vertical, with Through-Hole Shell Stakes			<b>Page</b>	3		
<b>Doc Number</b>	USB3140	<b>Prepared</b>	<b>CC</b>	<b>Checked</b>	<b>RM</b>	<b>Approved</b>	<b>VJ</b>

## 6.1 Electrical Performance.

Item	Test Condition	Requirement
Low-signal Level Contact Resistance	When measured at 20mV maximum open circuit at 100mA. Mated test contacts must be in a connector housing In accordance with EIA-364-23.	30 mΩ Max.
Insulation Resistance	Mate/Un-mate connectors, apply 100V DC for 1 minute at sea level between adjacent terminal or ground. In accordance with EIA-364-21.	1000 MΩ Min.
Dielectric Strength	Mate/Un-mate connectors, apply 100V AC for 1 minute at sea level. In accordance with EIA-364-20.	No Breakdown.

## 6.2 Mechanical Performance.

Item	Test Condition	Requirement
Mating/Un-mating Force	Mate/Un-mated at a rate of 12.5mm/min. In accordance with EIA-364-13.	Mating force: 35N Max. Un-Mating force: 8N Min. to 25N Max.
Durability	10,000 cycles at a cycle rate of 500 cycles per hour if done automatically and 200 if manual cycles. In accordance with EIA-364-09.	Mating force: 35N Max. Un-Mating force: 8N Min. to 25N Max Low Level Contact Resistance: 30mΩ Max.
Vibration	Mate connectors and subject to 5.35 Gs RMS. For a period of 15 minutes in each of the 3 mutually perpendicular axes. In accordance with EIA-364-28 Test condition V test letter A.	Appearance: No Damage. Contact Resistance: 50 mΩ Max. Discontinuity: 1.0 μ second Max.
Mechanical Shock	Mate connectors and subject to the following shock conditions, 3 shocks shall be applied along 3 mutually perpendicular axis (Total of 18 shocks). Test Pulse at Half Sine Peak Value: 294 m/s <sup>2</sup> (30G) Duration: 11ms. In accordance with EIA-364-27. Test condition H.	Appearance: No Damage. Contact Resistance: 10 mΩ Max. Change allowed. Discontinuity: 1.0 μ second Max.

# PRODUCT SPECIFICATION

<b>Part Number</b>	USB3140	<b>Rev</b>	A1	<b>Date</b>	31/07/17		
<b>Product Description</b>	Micro USB Receptacle, Type B, 5 Pins, SMT, Vertical, with Through-Hole Shell Stakes			<b>Page</b>	4		
<b>Doc Number</b>	USB3140	<b>Prepared</b>	<b>CC</b>	<b>Checked</b>	<b>RM</b>	<b>Approved</b>	<b>VJ</b>

## 6.3 Environmental Performance and Others.

Item	Test Condition	Requirement
Humidity Test	Subject mated connectors to Duration: 168 hours temperature between -25°C to +65°C with 90 to 95% RH. In accordance with EIA-364-31. Test condition A method III	Appearance: No Damage. Contact Resistance: 10 mΩ Max. change allowed. Insulation Resistance: 1000 MΩ Min. Dielectric Strength: No Breakdown.
Salt Spray	Subject mated/unmated connectors to 5% salt-solution concentration, 35°C for 48 hours. In accordance with EIA-364-26, Test Condition B.	Low Level Contact Resistance: 50mΩ Max. No visible rust
Temperature Life	Subject mated connectors to temperature life at +85°C for 96hours. In accordance with EIA-364-17. Test condition 2 Method A.	Contact Resistance: 10 mΩ Max. Change allowed. Insulation Resist: 1000 MΩ Min. Shall meet visual requirement and show no physical damage.
Temperature Rise	Mate connector and measure the temperature rise of contact when the maximum rated current is passed and in accordance with EIA-364-70.	+30°C Max. Change allowed.
Thermal Shock	Mate module and subject to follow condition for 10 cycles. At -55°C to +85°C. In accordance with EIA-364-32, test condition I.	No Damage 10mΩ Max. change allowed. Insulation Resist: 1000 MΩ Min. Dielectric Strength: No Breakdown.
Solderability	Dip solder-tails in flux then immerse in solder bath at 245 ±5°C up to 0.5mm from the bottom of the housing for 4~5 seconds. In accordance with EIA-364-52, category 2.	95% of immersed area must show no voids, pin holes.
Resistance to Soldering Heat (Reflow Soldering)	Sample mounted on PCB and subject to solder bath method, Temperature: 260°C for 10±1 sec In accordance with EIA-364-56.	Without deformation of shell or excessive looseness of the terminals (pin.)
Resistance to Soldering Heat (Hand Soldering)	Sample mounted on PCB and subject to hand iron soldering, Temperature: 350±10°C for 3±1 sec	Without deformation of shell or excessive looseness of the terminals (pin.)
Resistance to Solder Heat (Wave Soldering)	Heat: 260±5°C, 10+2/-0 sec. In accordance with EIA-364-56	Without deformation of shell or excessive looseness of the terminals (pin.)

# PRODUCT SPECIFICATION

<b>Part Number</b>	USB3140	<b>Rev</b>	A1	<b>Date</b>	31/07/17
<b>Product Description</b>	Micro USB Receptacle, Type B, 5 Pins, SMT, Vertical, with Through-Hole Shell Stakes			<b>Page</b>	5
<b>Doc Number</b>	USB3140	<b>Prepared</b>	<b>CC</b>	<b>Checked</b>	<b>RM</b>
				<b>Approved</b>	<b>VJ</b>

## 7.0 RESISTANCE TO INFRARED REFLOW SOLDERING HEAT

7.1 Lead Free Process: Reflow soldering cycles limited to two times

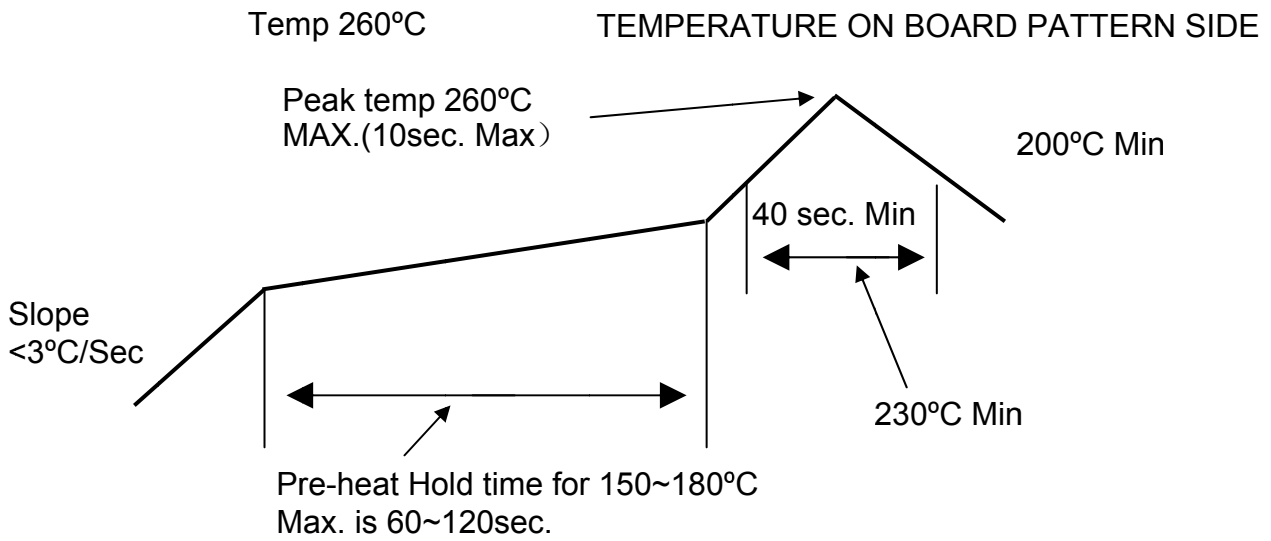

# PRODUCT SPECIFICATION



<b>Part Number</b>	USB3140	<b>Rev</b>	A1	<b>Date</b>	31/07/17		
<b>Product Description</b>	Micro USB Receptacle, Type B, 5 Pins, SMT, Vertical, with Through-Hole Shell Stakes			<b>Page</b>	6		
<b>Doc Number</b>	USB3140	<b>Prepared</b>	<b>CC</b>	<b>Checked</b>	<b>RM</b>	<b>Approved</b>	<b>VJ</b>

## 8.0 PRODUCT QUALIFICATION AND TEST SEQUENCE

Test Item	Test Group									
	1	2	3	4	5	6	7	8	9	10
Examination of Product				1,6	1,6	1,4	1,3	1,3	1,3	1,3
Low-signal Level Contact Resistance		1,5	1,4	2,9	2,9	2,5				
Insulation Resistance				3,8	3,8					
Dielectric Withstanding Voltage				4,7	4,7					
Mating / Unmating Forces		2,4								
Durability		3								
Vibration			2							
Mechanical Shock			3							
Humidity				5						
Salt Spray						3				
Temp Life					5					
Temp Rise	1									
Thermal Shock		4								
Solderability							2			
Resistance to Wave Soldering Heat								2		
Resistance to HandSoldering Heat									2	
Resistance to ReflowSoldering Heat										2

## Looking for pricing, stock, or lifecycle information?

Click below to explore more details on WIN SOURCE:

-  [View USB3140-30-0170-1-C on WIN SOURCE](#)
-  [GCT Information](#)

## Optimize Your Supply Chain with WIN SOURCE Solutions

-  Global Sourcing Solution
-  Obsolete Management
-  Cost Control Management
-  Shortage Management
-  Alternative Solution
-  Excess Inventory Management