



**THE DATASHEET OF
UPSD3434E-40U6**





UPSD3422 UPSD3433 UPSD3434 UPSD3454

Turbo Plus series
Fast Turbo 8032 MCU with USB and programmable logic

Features

- Fast 8-bit Turbo 8032 MCU, 40 MHz
 - Advanced core, 4-clocks per instruction
 - 10 MIPs peak performance at 40 MHz (5 V)
 - JTAG debug and in-system programming
 - 16-bit internal instruction path fetches double-byte instruction in a single memory cycle
 - Branch cache & 4 instruction prefetch queue
 - Dual XDATA pointers with automatic increment and decrement
 - Compatible with 3rd party 8051 tools
- Dual Flash memories with memory management
 - Place either memory into 8032 program address space or data address space
 - READ-while-WRITE operation for in-application programming and EEPROM emulation
 - Single voltage program and erase
 - 100 000 guaranteed erase cycles, 15-year retention
- Clock, reset, and power supply management
 - Flexible 8-level CPU clock divider register
 - Normal, Idle, and power-down modes
 - Power-on-reset and low-voltage-reset supervisor
 - Programmable watchdog timer
- Programmable logic, general purpose
 - 16 macrocells for logic applications (e.g., shifters, state machines, chip-selects, glue-logic to keypads, and LCDs)
- A/D converter
 - Eight channels, 10-bit resolution, 6 μ s
- Operating voltage source ($\pm 10\%$)
 - 5 V devices: 5.0 V and 3.3 V sources
 - 3.3 V devices: 3.3 V source

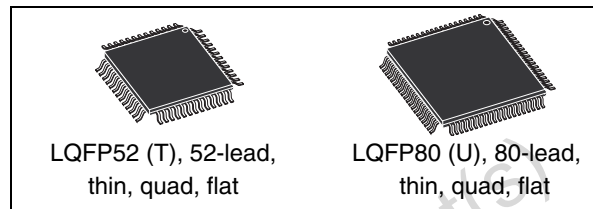

- Communication interfaces
 - USB v2.0 Full Speed (12Mbps)
 - 10 endpoint pairs (In/Out), each endpoint with 64-byte FIFO (supports Control, In, and Bulk transfer types)
 - I²C Master/Slave controller, 933kHz
 - SPI Master controller, 10MHz
 - Two UARTs with independent baud rate
 - IrDA protocol: up to 115 kbaud
 - Up to 43 V/O, 5 V tolerant uPSD34xxV
- Timers and interrupts
 - Three 8032 standard 16-bit timers
 - Programmable counter array (PCA), six 16-bit modules for PWM, CAPCOM, and timers
 - 8/10/16-bit PWM operation
 - 12 Interrupt sources with two external interrupt pins
- Packages
 - ECOPACK[®] compliant

Table 1. Device summary

Reference	Part number
uPSD3422	UPSD3422E, UPSD3422EV
uPSD3433E	UPSD3433E, UPSD3433EV
uPSD3434	UPSD3434E, UPSD3434EV
uPSD3454	UPSD3454E, UPSD3454EV

Contents

1	Description	20
2	Pin descriptions	22
3	Hardware description	28
4	Memory organization	30
4.1	Internal memory (MCU module, standard 8032 memory: DATA, IDATA, SFR)	31
4.1.1	DATA memory	31
4.1.2	IDATA memory	31
4.1.3	SFR memory	31
4.2	External memory (PSD module: program memory, data memory)	31
4.2.1	Program memory	32
4.2.2	Data memory	32
4.2.3	Memory placement	32
5	8032 MCU core performance enhancements	33
5.1	Pre-fetch queue (PFQ) and branch cache (BC)	34
5.2	PFQ example, multi-cycle instructions	35
5.3	Aggregate performance	35
6	MCU module description	37
7	8032 MCU registers	38
7.1	Stack pointer (SP)	38
7.2	Data pointer (DPTR)	38
7.3	Program counter (PC)	38
7.4	Accumulator (ACC)	39
7.5	B register (B)	39
7.6	General purpose registers (R0 - R7)	39
7.7	Program status word (PSW)	39
7.7.1	Carry flag (CY)	39
7.7.2	Auxiliary carry flag (AC)	39

7.7.3	General purpose flag (F0)	39
7.7.4	Register bank select flags (RS1, RS0)	39
7.7.5	Overflow flag (OV)	40
7.7.6	Parity flag (P)	40
8	Special function registers (SFR)	41
9	8032 addressing modes	48
9.1	Register addressing	48
9.2	Direct addressing	48
9.3	Register indirect addressing	48
9.4	Immediate addressing	49
9.5	External direct addressing	49
9.6	External indirect addressing	49
9.7	Indexed addressing	50
9.8	Relative addressing	50
9.9	Absolute addressing	50
9.10	Long addressing	50
9.11	Bit addressing	51
10	UPSD34xx instruction set summary	52
11	Dual data pointers	57
11.1	Data pointer control register, DPTC (85h)	57
11.2	Data pointer mode register, DPTM (86h)	58
11.2.1	Firmware example	58
12	Debug unit	60
13	Interrupt system	62
13.1	Individual interrupt sources	64
13.1.1	External interrupts Int0 and Int1	64
13.1.2	Timer 0 and 1 overflow interrupt	65
13.1.3	Timer 2 overflow interrupt	65
13.1.4	UART0 and UART1 interrupt	65
13.1.5	SPI interrupt	65

13.1.6	I ² C interrupt	65
13.1.7	ADC interrupt	65
13.1.8	PCA interrupt	65
13.1.9	USB interrupt	66
14	MCU clock generation	68
14.1	MCU_CLK	68
14.2	PERIPH_CLK	68
14.2.1	JTAG interface clock	68
14.2.2	USB_CLK	69
15	Power saving modes	72
15.1	Idle mode	72
15.2	Power-down mode	73
15.3	Reduced frequency mode	73
16	Oscillator and external components	76
17	I/O ports of mcu module	78
17.1	MCU port operating modes	78
17.1.1	GPIO function	79
17.1.2	GPIO output	79
17.1.3	GPIO input	79
17.1.4	Alternate functions	83
18	MCU bus interface	86
18.1	PSEN bus cycles	86
18.2	READ or WRITE bus cycles	86
18.3	Connecting external devices to the MCU bus	86
18.4	Programmable bus timing	87
18.5	Controlling the PFQ and BC	88
19	Supervisory functions	91
19.1	External reset input pin, RESET_IN	91
19.2	Low V _{CC} voltage detect, LVD	92
19.3	Power-up reset	92

19.4	JTAG debug reset	92
19.5	Watchdog timer, WDT	92
19.5.1	Firmware example	94
20	Standard 8032 timer/counters	96
20.1	Standard timer SFRs	96
20.2	Clock sources	96
20.3	SFR, TCON	97
20.4	SFR, TMOD	98
20.5	Timer 0 and Timer 1 operating modes	98
20.5.1	Mode 0	98
20.5.2	Mode 1	98
20.5.3	Mode 2	98
20.5.4	Mode 3	98
20.6	Timer 2	100
20.6.1	Capture mode	101
20.6.2	Auto-reload mode	101
20.6.3	Baud rate generator mode	103
21	Serial UART interfaces	107
21.1	UART operation modes	107
21.1.1	Mode 0	107
21.1.2	Mode 1	107
21.1.3	Mode 2	108
21.1.4	Mode 3	108
21.1.5	Multiprocessor communications	108
21.2	Serial port control registers	109
21.3	UART baud rates	110
21.3.1	Using timer 1 to generate baud rates	111
21.3.2	Using timer/counter 2 to generate baud rates	111
21.4	More about UART mode 0	112
21.5	More about UART mode 1	114
21.6	More about UART modes 2 and 3	116
22	IrDA interface	119
22.1	Baud rate selection	120

22.2	Pulse width selection	121
23	I²C interface	123
23.1	I2C interface main features	123
23.2	Communication flow	124
23.3	Operating modes	125
23.4	Bus arbitration	126
23.5	Clock synchronization	126
23.5.1	Clock sync during arbitration	126
23.5.2	Clock sync during handshaking	126
23.6	General call address	127
23.7	Serial I/O engine (SIOE)	127
23.8	I ² C interface control register (S1CON)	129
23.9	I ² C interface status register (S1STA)	130
23.9.1	Interrupt conditions	130
23.10	I2C data shift register (S1DAT)	131
23.10.1	Bus wait condition	132
23.11	I ² C address register (S1ADR)	132
23.12	I ² C Start sample setting (S1SETUP)	133
23.13	I ² C operating sequences	135
23.13.1	Interrupt service routine (ISR)	138
24	SPI (synchronous peripheral interface)	142
24.1	SPI bus features and communication flow	143
24.2	Full-duplex operation	143
24.3	Bus-level activity	143
24.4	SPI SFR registers	145
24.5	SPI configuration	146
24.6	Dynamic control	147
25	USB interface	150
25.1	Basic USB concepts	151
25.1.1	Communication flow	151
25.1.2	Endpoints	152
25.1.3	Packets	152

25.1.4	Data transfers with the host	153
25.2	Types of transfers	154
25.2.1	Enumeration	155
25.3	Endpoint FIFOs	156
25.3.1	Busy bit (BSY) operation	156
25.3.2	Busy bit and interrupts	156
25.3.3	FIFO pairing	157
25.3.4	Reading and writing FIFOs	159
25.3.5	Accessing FIFO control registers, UCON, and USIZE	159
25.3.6	Accessing the setup command buffer	160
25.4	USB registers	160
25.4.1	USB device address register	161
25.4.2	Endpoint FIFO pairing	162
25.4.3	USB interrupts	163
25.5	Typical connection to USB	177
26	Analog-to-digital convertor (ADC)	178
26.1	Port 1 ADC channel selects	178
27	Programmable counter array (PCA) with PWM	181
27.1	PCA block	181
27.2	PCA clock selection	182
27.3	Operation of TCM modes	183
27.4	Capture mode	183
27.5	Timer mode	183
27.6	Toggle mode	184
27.7	PWM mode - (x8), fixed frequency	184
27.8	PWM mode - (x8), programmable frequency	185
27.9	PWM mode - fixed frequency, 16-bit	186
27.10	PWM mode - fixed frequency, 10-bit	187
27.11	Writing to capture/compare registers	187
27.12	Control register bit definition	187
27.13	TCM interrupts	189
28	PSD module	191

28.1	PSD module functional description	192
28.1.1	8032 address/data/control interface	192
28.1.2	Dual Flash memories and IAP	192
28.1.3	Main Flash memory	192
28.1.4	Secondary Flash memory	193
28.1.5	SRAM	193
28.1.6	Runtime control registers, csiop	193
28.1.7	Memory page register	193
28.1.8	Programmable logic (PLDs)	194
28.1.9	PLD #1, decode PLD (DPLD)	194
28.1.10	PLD #2, general PLD (GPLD)	194
28.1.11	OMCs	195
28.1.12	OMC allocator	195
28.1.13	IMCs	195
28.1.14	I/O ports	195
28.1.15	JTAG port	196
28.1.16	Power management	197
28.1.17	Security and NVM sector protection	197
28.2	Memory mapping	197
28.2.1	8032 program address space	198
28.2.2	8032 data address space (XDATA)	198
28.2.3	Specifying the memory map with PSDsoft express	198
28.2.4	EEPROM emulation	199
28.2.5	Alternative mapping schemes	200
28.2.6	Memory sector select rules	202
28.2.7	The VM register	203
28.3	PSD module data bus width	204
28.4	Runtime control register definitions (csiop)	205
28.5	PSD module detailed operation	207
28.5.1	Flash memory operation	207
28.5.2	Flash memory instruction sequences	208
28.5.3	Reading Flash memory	210
28.5.4	Read memory contents	210
28.5.5	Reading the erase/program status bits	210
28.5.6	Data polling flag (DQ7)	210
28.5.7	Toggle flag (DQ6)	211

28.5.8	Error flag (DQ5)	211
28.5.9	Erase time-out flag (DQ3)	212
28.5.10	Programming Flash memory	212
28.5.11	Data polling	213
28.5.12	Data toggle	214
28.5.13	Ready/Busy (PC3)	215
28.5.14	Bypassed unlock sequence	215
28.5.15	Erasing Flash memory	216
28.5.16	Flash bulk erase	216
28.5.17	Flash sector erase	216
28.5.18	Suspend sector erase	217
28.5.19	Resume sector erase	217
28.5.20	Reset Flash	218
28.5.21	Reset signal applied to Flash memory	218
28.5.22	Flash memory sector protection	218
28.5.23	Flash memory protection during power-up	218
28.5.24	PSD module security bit	218
28.5.25	PLDs	219
28.5.26	Turbo bit and PLDs	220
28.5.27	Decode PLD (DPLD)	222
28.5.28	General PLD (GPLD)	223
28.5.29	Output macrocell	225
28.5.30	OMC allocator	226
28.5.31	Product term allocator	226
28.5.32	Loading and reading OMCs	228
28.5.33	OMC mask registers	229
28.5.34	Input macrocells	229
28.5.35	I/O ports	231
28.5.36	General port architecture	231
28.5.37	Port operating modes	231
28.5.38	MCU I/O mode	233
28.5.39	PLD I/O mode	236
28.5.40	Latched address output mode	238
28.5.41	Peripheral I/O mode	239
28.5.42	JTAG ISP mode	240
28.5.43	Other port capabilities	240
28.5.44	Port pin drive options	240

28.5.45	Drive select registers	240
28.5.46	Enable out registers	240
28.5.47	Individual port structures	243
28.5.48	Port A structure	243
28.5.49	Port B structure	244
28.5.50	Port C structure	245
28.5.51	Port D structure	246
28.5.52	Power management	248
28.5.53	Automatic power-down (APD)	250
28.5.54	Forced power-down (FDP)	251
28.5.55	Chip select input (CSI)	253
28.5.56	PLD non-turbo mode	253
28.5.57	PLD current consumption	254
28.5.58	Turbo mode current consumption	254
28.5.59	Non-turbo mode current consumption	254
28.5.60	PLD blocking bits	255
28.5.61	Blocking 8032 bus control signals	255
28.5.62	Blocking common clock, CLKIN	255
28.6	PSD module reset conditions	255
28.6.1	JTAG ISP and JTAG debug	257
28.6.2	JTAG chaining inside the package	257
28.6.3	In-system programming	258
28.6.4	4-pin JTAG ISP (default)	259
28.6.5	6-pin JTAG ISP (optional)	260
28.6.6	Recommended JTAG connector	261
28.6.7	Chaining UPSD34xx devices	262
28.6.8	Debugging the 8032 MCU module	263
28.6.9	JTAG security setting	264
28.6.10	Initial delivery state	264
29	AC/DC parameters	265
30	Maximum rating	268
31	DC and AC parameters	269
32	Package mechanical information	289

33	Part numbering	292
34	Important notes	294
	34.1 USB interrupts with idle mode	294
	34.2 USB reset interrupt	294
	34.3 USB reset	294
	34.4 Data toggle	295
	34.5 USB FIFO accessibility	295
	34.6 Erroneous resend of data packet	295
	34.7 IN FIFO pairing operation	296
	34.8 OUT FIFO pairing operation	296
	34.9 Missing ACK to host retransmission of SETUP packet	296
	34.10 MCU JTAG ID	297
	34.11 Port 1 not 5-volt IO tolerant	297
	34.12 Incorrect code execution when code banks are switched	298
	34.13 9 th received data bit corrupted in UART modes 2 and 3	298
35	Revision history	299

Obsolete Product(s) - Obsolete Product(s)
 Obsolete Product(s) - Obsolete Product(s)

List of tables

Table 1.	Device summary	1
Table 2.	Pin definitions	24
Table 3.	Port type and voltage source combinations	28
Table 4.	Register bank select addresses	40
Table 5.	SFR memory map with direct address and reset value	42
Table 6.	Arithmetic instruction set.	52
Table 7.	Logical instruction set	53
Table 8.	Data transfer instruction set	54
Table 9.	Boolean variable manipulation instruction set	55
Table 10.	Program branching instruction set	55
Table 11.	Miscellaneous instruction set	56
Table 12.	Notes on instruction set and addressing modes.	56
Table 13.	DPTC: data pointer control register (SFR 85h, reset value 00h)	57
Table 14.	DPTC register bit definition.	57
Table 15.	DPTM: data pointer mode register (SFR 86h, reset value 00h)	58
Table 16.	DPTM register bit definition	58
Table 17.	Interrupt summary.	63
Table 18.	IE: interrupt enable register (SFR A8h, reset value 00h)	66
Table 19.	IE register bit definition	66
Table 20.	IEA: interrupt enable addition register (SFR A7h, reset value 00h)	66
Table 21.	IEA register bit definition.	66
Table 22.	IP: interrupt priority register (SFR B8h, reset value 00h)	67
Table 23.	IP register bit definition	67
Table 24.	IPA: Interrupt Priority Addition register (SFR B7h, reset value 00h)	67
Table 25.	IPA register bit definition.	67
Table 26.	PLLM and PLLD values for different f_{OSC} frequencies	69
Table 27.	CCON0: clock control register (SFR F9h, reset value 50h)	70
Table 28.	CCON0 register bit definition	70
Table 29.	CCON1 PLL control register (SFR FAh, reset value 00h)	71
Table 30.	CCON1 register bit definition	71
Table 31.	MCU module port and peripheral status during reduced power modes	74
Table 32.	State of 8032 MCU bus signals during power-down and idle modes	74
Table 33.	PCON: power control register (SFR 87h, reset value 00h).	74
Table 34.	PCON register bit definition	74
Table 35.	P1: I/O port 1 register (SFR 90h, reset value FFh)	81
Table 36.	P1 register bit definition	81
Table 37.	P3: I/O port 3 register (SFR B0h, reset value FFh)	82
Table 38.	P3 register bit definition	82
Table 39.	P4: I/O port 4 register (SFR C0h, reset value FFh)	82
Table 40.	P4 register bit definition	82
Table 41.	P3SFS: Port 3 special function select register (SFR 91h, reset value 00h)	84
Table 42.	P3SFS register bit definition	84
Table 43.	P1SFS0: Port 1 special function select 0 register (SFR 8Eh, reset value 00h)	84
Table 44.	P1SFS1: Port 1 special function select 1 register (SFR 8Fh, reset value 00h)	84
Table 45.	P1SFS0 and P1SFS1 details	84
Table 46.	P4SFS0: Port 4 special function select 0 register (SFR 92h, reset value 00h).	85
Table 47.	P4SFS1: Port 4 special function select 1 register (SFR 93h, reset value 00h).	85
Table 48.	P4SFS0 and P4SFS1 details	85

Table 49.	BUSCON: bus control register (SFR 9Dh, reset value EBh)	88
Table 50.	BUSCON register bit definition	89
Table 51.	Number of MCU_CLK periods required to optimize bus transfer rate	90
Table 52.	WDKEY: Watchdog timer key register (SFR AEh, reset value 55h)	94
Table 53.	WDKEY register bit definition	94
Table 54.	WDRST: Watchdog timer reset counter register (SFR A6h, reset value 00h)	94
Table 55.	WDRST register bit definition	95
Table 56.	TCON: Timer control register (SFR 88h, reset value 00h)	97
Table 57.	TCON register bit definition	97
Table 58.	TMOD: Timer mode register (SFR 89h, reset value 00h)	99
Table 59.	TMOD register bit definition	99
Table 60.	T2CON: Timer 2 control register (SFR C8h, reset value 00h)	101
Table 61.	T2CON register bit definition	101
Table 62.	Timer/counter 2 operating modes	102
Table 63.	Commonly used baud rates generated from timer2 (T2CON = 34h)	104
Table 64.	UART operating modes	108
Table 65.	SCON0: serial port UART0 control register (SFR 98h, reset value 00h)	109
Table 66.	SCON0 register bit definition	109
Table 67.	SCON1: serial port UART1 control register (SFR D8h, reset value 00h)	109
Table 68.	SCON1 register bit definition	110
Table 69.	Commonly used baud rates generated from timer 1	111
Table 70.	IRDACON register bit definition (SFR CEh, reset value 0Fh)	120
Table 71.	IRDACON register bit definition	120
Table 72.	Baud rate selection register (SFR xxh, reset value xxh)	120
Table 73.	Baud rate of UART#1 for IrDA interface	121
Table 74.	Recommended CDIV[4:0] values to generate SIRCk (default CDIV[4:0] = 0Fh, 15 decimal)	122
Table 75.	Serial control register S1CON (SFR DCh, reset value 00h)	129
Table 76.	S1CON register bit definition	129
Table 77.	Selection of the SCL frequency in Master mode based on f _{OSC} examples	130
Table 78.	S1STA: I ² C interface status register (SFR DDh, reset value 00h)	130
Table 79.	S1STA register bit definition	131
Table 80.	S1DAT: I2C data shift register (SFR DEh, reset value 00h)	132
Table 81.	S1DAT register bit definition	132
Table 82.	S1ADR: I2C address register (SFR DFh, reset value 00h)	132
Table 83.	S1ADR register bit definition	132
Table 84.	S1SETUP: I ² C Start condition sample setup register (SFR DBh, reset value 00h)	133
Table 85.	S1SETUP register bit definition	133
Table 86.	Number of I ² C bus samples taken after 1-to-0 transition on SDA (Start condition)	134
Table 87.	Start condition hold time	134
Table 88.	S1SETUP examples for various I ² C bus speeds and oscillator frequencies	134
Table 89.	SPICON0: control register 0 (SFR D6h, reset value 00h)	147
Table 90.	SPICON0 register bit definition	147
Table 91.	SPICON1: SPI interface control register 1 (SFR D7h, reset value 00h)	148
Table 92.	SPICON1 register bit definition	148
Table 93.	SPICLKD: SPI prescaler (clock divider) register (SFR D2h, reset value 04h)	148
Table 94.	SPICLKD register bit definition	149
Table 95.	SPISTAT: SPI interface status register (SFR D3h, reset value 02h)	149
Table 96.	SPISTAT register bit definition	149
Table 97.	Types of packet IDs	152

Table 98.	UPSD34xx supported endpoints	157
Table 99.	UPSD34xx USB SFR register map	160
Table 100.	USB device address register (UADDR 0E2h, reset value 00h)	162
Table 101.	UADDR register bit definition	162
Table 102.	Pairing control register (UPAIR 0E3h, reset value 00h)	162
Table 103.	UPAIR register bit definition	162
Table 104.	USB global interrupt enable register (UIE0 0E4h, reset value 00h)	163
Table 105.	UIE0 register bit definition	164
Table 106.	USB IN FIFO interrupt enable register (UIE1 0E5h, reset value 00h)	164
Table 107.	UIE1 register bit definition	164
Table 108.	USB OUT FIFO interrupt enable register (UIE2 0E6h, reset value 00h)	164
Table 109.	UIE2 register bit definition	165
Table 110.	USB IN FIFO NAK interrupt enable register (UIE3 0E7h, reset value 00h)	165
Table 111.	UIE3 register bit definition	165
Table 112.	USB global interrupt flag register (UIF0 0E8h, reset value 00h)	166
Table 113.	UIF0 register bit definition	166
Table 114.	USB IN FIFO interrupt flag (UIF1 0E9h, reset value 00h)	167
Table 115.	UIF1 register bit definition	167
Table 116.	USB OUT FIFO interrupt flag (UIF2 0EAh, reset value 00h)	168
Table 117.	UIF2 register bit definition	168
Table 118.	USB IN FIFO NAK interrupt flag (UIF3 0EBh, reset value 00h)	169
Table 119.	UIF3 register bit definition	169
Table 120.	USB control register (UCTL 0ECh, reset value 00h)	170
Table 121.	UCTL register bit definition	170
Table 122.	USB endpoint0 status (USTA 0EDh, reset value 00h)	171
Table 123.	USTA register bit definition	171
Table 124.	USB endpoint select register (USEL 0EFh, reset value 00h)	172
Table 125.	USEL register bit definition	172
Table 126.	USB endpoint control register (UCON 0F1h, reset value 08h)	173
Table 127.	UCON register bit definition	173
Table 128.	USB FIFO valid size (USIZE 0F2h, reset value 00h)	174
Table 129.	USIZE register bit definition	174
Table 130.	USB FIFO base address high register (UBASEH 0F3h, reset value 00h)	175
Table 131.	UBASEH register bit definition	175
Table 132.	USB FIFO base address low register (UBASEL 0F4h, reset value 00h)	175
Table 133.	UBASEL register bit definition	175
Table 134.	USB setup command index register (USCI 0F5h, reset value 00h)	176
Table 135.	USCI register bit definition	176
Table 136.	USB setup command value register (USCV 0F6h, reset value 00h)	176
Table 137.	USCV register bit definition	176
Table 138.	ACON register (SFR 97h, reset value 00h)	179
Table 139.	ACON register bit definition	179
Table 140.	ADCPS register details (SFR 94h, Reset Value 00h)	180
Table 141.	ADAT0 register (SFR 95h, reset value 00h)	180
Table 142.	ADAT1 register (SFR 96h, reset value 00h)	180
Table 143.	PCA0 and PCA1 registers	182
Table 144.	CCON2 register bit definition (SFR 0FBh, reset value 10h)	183
Table 145.	CCON2 register bit definition	183
Table 146.	CCON3 register bit definition (SFR 0FCh, reset value 10h)	183
Table 147.	CCON3 register bit definition	183
Table 148.	PCA0 control register PCACON0 (SFR 0A4h, reset value 00h)	187
Table 149.	PCA0 register bit definition	187

Table 150.	PCA1 control register PCACON1 (SFR 0BCh, reset value 00h)	188
Table 151.	PCA1 register bit definition	188
Table 152.	PCA status register PCASTA (SFR 0A5h, reset value 00h)	188
Table 153.	PCASTA register bit definition	188
Table 154.	TCMMODE0 - TCMMODE5 (6 registers, reset value 00h)	189
Table 155.	TCMMODE0 - TCMMODE5 register bit definition	189
Table 156.	TCMMODE register configurations	190
Table 157.	UPSD34xx memory configuration	193
Table 158.	General I/O pins on PSD module	196
Table 159.	HDL statement example generated from PSDsoft express for memory map	199
Table 160.	VM register (address = csiop + offset E2h)	203
Table 161.	Data width in different bus cycles	205
Table 162.	CSIOP registers and their offsets (in hexadecimal)	205
Table 163.	Flash memory instruction sequences	209
Table 164.	Flash memory status bit definition	212
Table 165.	Main Flash memory protection register definition (address = csiop + offset C0h)	219
Table 166.	Secondary Flash memory protection/security register definition (csiop + offset C2h)	219
Table 167.	DPLD and GPLD inputs	220
Table 168.	OMC port and data bit assignments	227
Table 169.	Output macrocell MCELLAB (address = csiop + offset 20h)	228
Table 170.	Output macrocell MCELLBC (address = csiop + offset 21h)	228
Table 171.	Output macrocell MCELLAB mask register (address = csiop + offset 22h)	229
Table 172.	Output macrocell MCELLBC mask register (address = csiop + offset 23h)	229
Table 173.	Input macrocell port A (address = csiop + offset 0Ah)	230
Table 174.	Input macrocell port B (address = csiop + offset 0Bh)	230
Table 175.	Input macrocell port C (address = csiop + offset 18h)	230
Table 176.	Port operating modes	232
Table 177.	Port configuration setting requirements	233
Table 178.	MCU I/O mode port A data in register (address = csiop + offset 00h)	234
Table 179.	MCU I/O mode port B data in register (address = csiop + offset 01h)	234
Table 180.	MCU I/O mode port C data in register (address = csiop + offset 10h)	234
Table 181.	MCU I/O mode port D Data in register (address = csiop + offset 11h)	234
Table 182.	MCU I/O mode port A data out register (address = csiop + offset 04h)	234
Table 183.	MCU I/O mode port B data out register (address = csiop + offset 05h)	235
Table 184.	MCU I/O mode port C data out register (address = csiop + offset 12h)	235
Table 185.	MCU I/O mode port D data out register (address = csiop + offset 13h)	235
Table 186.	MCU I/O mode port A direction register (address = csiop + offset 06h)	235
Table 187.	MCU I/O mode port B direction in register (address = csiop + offset 07h)	235
Table 188.	MCU I/O mode port C direction register (address = csiop + offset 14h)	235
Table 189.	MCU I/O mode port D direction register (address = csiop + offset 15h)	236
Table 190.	Latched address output, port A contro register(address = csiop + offset 02h) 	238
Table 191.	Latched address output, port B contro register (address = csiop + offset 03h) 	239
Table 192.	Port A pin drive select register (address = csiop + offset 08h)	241
Table 193.	Port B pin drive select register (address = csiop + offset 09h)	242
Table 194.	Port C pin drive select register (address = csiop + offset 16h)	242
Table 195.	Port D pin drive select register (address = csiop + offset 17h)	242
Table 196.	Port A enable out register (address = csiop + offset 0Ch)	242
Table 197.	Port B enable out register (address = csiop + offset 0Dh)	242
Table 198.	Port C enable out register (address = csiop + offset 1Ah)	242
Table 199.	Port D enable out register (address = csiop + offset 1Bh)	242
Table 200.	Power management mode register PMMR0 (address = csiop + offset B0h)	249
Table 201.	Power management mode register PMMR2 (address = csiop + offset B4h)	249

Table 202.	Power management mode register PMMR3 (address = csiop + offset C7h)	250
Table 203.	Function status during power-up reset, warm reset, power-down mode	256
Table 204.	PSD module example, typ. power calculation at $V_{CC} = 5.0\text{ V}$ (turbo mode off)	266
Table 205.	Absolute maximum ratings	268
Table 206.	Operating conditions (5 V devices)	269
Table 207.	Operating conditions (3.3 V devices)	269
Table 208.	AC signal letters for timing	269
Table 209.	AC signal behavior symbols for timing	270
Table 210.	Major parameters	271
Table 211.	MCU module DC characteristics	271
Table 212.	PSD module DC characteristics (with 5 V V_{DD})	273
Table 213.	PSD module DC characteristics (with 3.3 V V_{DD})	274
Table 214.	External READ cycle AC characteristics (3 V or 5 V device)	275
Table 215.	n, m, and x, y values	275
Table 216.	External WRITE cycle AC characteristics (3 V or 5 V device)	276
Table 217.	External clock drive	277
Table 218.	A/D analog specification	277
Table 219.	USB transceiver specification	277
Table 220.	CPLD combinatorial timing (5 V PSD module)	279
Table 221.	CPLD combinatorial timing (3 V PSD module)	279
Table 222.	CPLD macrocell synchronous clock mode timing (5 V PSD module)	280
Table 223.	CPLD macrocell synchronous clock mode timing (3 V PSD module)	281
Table 224.	CPLD macrocell asynchronous clock mode timing (5 V PSD module)	282
Table 225.	CPLD macrocell asynchronous clock mode timing (3 V PSD module)	282
Table 226.	Input macrocell timing (5 V PSD module)	283
Table 227.	Input macrocell timing (3 V PSD module)	283
Table 228.	Program, WRITE and erase times (5 V, 3 V PSD modules)	283
Table 229.	Port A peripheral data mode READ timing (5 V PSD module)	284
Table 230.	Port A peripheral data mode READ timing (3 V PSD module)	285
Table 231.	Port A peripheral data mode WRITE timing (5 V PSD module)	285
Table 232.	Port A peripheral data mode WRITE timing (3 V PSD module)	285
Table 233.	Supervisor reset and LVD	286
Table 234.	ISC timing (5 V PSD module)	286
Table 235.	ISC timing (3 V PSD module)	287
Table 236.	I/O pin capacitance	288
Table 237.	LQFP52 – 52-lead plastic thin, quad, flat package mechanical data	290
Table 238.	LQFP80 – 80-lead plastic thin, quad, flat package mechanical data	291
Table 239.	Ordering information scheme	292
Table 240.	Order codes	293
Table 241.	Document revision history	299

List of figures

Figure 1.	Block diagram	21
Figure 2.	LQFP52 connections	22
Figure 3.	LQFP80 connections	23
Figure 4.	Functional modules	29
Figure 5.	UPSD34xx memories	30
Figure 6.	Comparison of UPSD34xx with standard 8032 performance	33
Figure 7.	Instruction pre-fetch queue and branch cache	34
Figure 8.	PFQ operation on multi-cycle instructions	35
Figure 9.	UPSD34xx multi-cycle instructions compared to standard 8032	36
Figure 10.	8032 MCU registers	38
Figure 11.	Program status word (PSW) register	40
Figure 12.	Enabling and polling interrupts	64
Figure 13.	Clock generation logic	70
Figure 14.	Oscillator and clock connections	77
Figure 15.	MCU module port pin function routing	80
Figure 16.	MCU I/O cell block diagram for port 1	80
Figure 17.	MCU I/O cell block diagram for port 3	81
Figure 18.	MCU I/O cell block diagram for port 4	81
Figure 19.	Connecting external devices using ports A and B for address AD[15:0]	87
Figure 20.	Connecting external devices using port A and an external latch for address AD[15:0]	87
Figure 21.	A RD or PSEN bus cycle set to 5 MCU_CLK	88
Figure 22.	Supervisor reset generation	91
Figure 23.	Watchdog counter	93
Figure 24.	Timer/counter mode 0: 13-bit counter	100
Figure 25.	Timer/counter mode 2: 8-bit Auto-reload	100
Figure 26.	Timer/counter mode 3: two 8-bit counters	100
Figure 27.	Timer 2 in capture mode	105
Figure 28.	Timer 2 in auto-reload mode	106
Figure 29.	Timer 2 in baud rate generator mode	106
Figure 30.	UART mode 0, block diagram	113
Figure 31.	UART mode 0, timing diagram	113
Figure 32.	UART mode 1, block diagram	115
Figure 33.	UART mode 1, timing diagram	115
Figure 34.	UART mode 2, block diagram	117
Figure 35.	UART mode 2, timing diagram	117
Figure 36.	UART mode 3, block diagram	118
Figure 37.	UART mode 3, timing diagram	118
Figure 38.	IrDA interface	119
Figure 39.	Pulse shaping by the IrDA interface	119
Figure 40.	Typical I2C bus configuration	123
Figure 41.	Data transfer on an I ² C bus	125
Figure 42.	I ² C interface SIOE block diagram	128
Figure 43.	SPI device connection examples	142
Figure 44.	SPI full-duplex data exchange	144
Figure 45.	SPI receive operation example	144
Figure 46.	SPI transmit operation example	145
Figure 47.	SPI interface, master mode only	146
Figure 48.	USB module block diagram	151

Figure 49.	USB packets in a USB transfer example	153
Figure 50.	IN and OUT bulk transfers	154
Figure 51.	Interrupt transfer	155
Figure 52.	Control transfer	156
Figure 53.	FIFOs with no pairing	158
Figure 54.	FIFO pairing example (1/2 IN paired and 3/4 OUT paired)	159
Figure 55.	Typical self powered example	177
Figure 56.	10-bit ADC	179
Figure 57.	PCA0 block diagram	181
Figure 58.	Timer mode	184
Figure 59.	PWM mode - (x8), fixed frequency	185
Figure 60.	PWM mode - (x8) programmable frequency	186
Figure 61.	PSD module block diagram	191
Figure 62.	Memory page register	194
Figure 63.	Typical system memory map	198
Figure 64.	PSDsoft express memory mapping	199
Figure 65.	Mapping: split second Flash in half	200
Figure 66.	Mapping: all Flash in code space	201
Figure 67.	Mapping: small code / big data	201
Figure 68.	PSD module memory priority	202
Figure 69.	VM register control of memories	204
Figure 70.	VM register example corresponding to memory map example	204
Figure 71.	Data polling flowchart	214
Figure 72.	Data toggle flowchart	215
Figure 73.	DPLD and GPLD	221
Figure 74.	DPLD logic array	223
Figure 75.	GPLD: one OMC, one IMC, and one I/O port (typical pin, port A, B, or C)	224
Figure 76.	Detail of a single OMC	226
Figure 77.	OMC allocator	227
Figure 78.	Detail of a single IMC	230
Figure 79.	Detail of a single I/O port (typical of ports A, B, C)	232
Figure 80.	Simple PLD logic example	237
Figure 81.	Pin declarations in PSDsoft express for simple PLD example	237
Figure 82.	Using the design assistant in PSDsoft Express for simple PLD example	238
Figure 83.	Peripheral I/O mode	239
Figure 84.	Port A structure	243
Figure 85.	Port B structure	244
Figure 86.	Port C structure	246
Figure 87.	Port D structure	247
Figure 88.	Automatic power-down (APD) unit	252
Figure 89.	Power-down mode flowchart	253
Figure 90.	JTAG chain in UPSD34xx package	258
Figure 91.	Recommended 4-pin JTAG connections	259
Figure 92.	Recommended 6-pin JTAG connections	261
Figure 93.	Recommended JTAG connector	262
Figure 94.	Example of chaining UPSD34xx devices	263
Figure 95.	PLD ICC / frequency consumption (5 V range)	265
Figure 96.	PLD ICC / frequency consumption (3 V range)	266
Figure 97.	Switching waveforms – key	270
Figure 98.	External READ cycle (80-pin device only)	275
Figure 99.	External WRITE cycle (80-pin device only)	276
Figure 100.	Input to output disable / enable	278

Figure 101. Synchronous Clock mode timing – PLD 280

Figure 102. Asynchronous RESET / Preset. 281

Figure 103. Asynchronous clock mode timing (product term clock). 281

Figure 104. Input macrocell timing (product term clock) 283

Figure 105. Peripheral I/O READ timing 284

Figure 106. Peripheral I/O WRITE timing 285

Figure 107. ISC timing 286

Figure 108. MCU module AC measurement I/O waveform 287

Figure 109. PSD module AC float I/O waveform 287

Figure 110. External clock cycle 288

Figure 111. PSD module AC measurement I/O waveform 288

Figure 112. PSD module AC measurement load circuit 288

Figure 113. LQFP52 – 52-lead plastic thin, quad, flat package outline 290

Figure 114. LQFP80 – 80-lead plastic thin, quad, flat package outline 291

Obsolete Product(s) - Obsolete Product(s)

Obsolete Product(s) - Obsolete Product(s)

1 Description

The *Turbo Plus* UPSD34xx Series combines a powerful 8051-based microcontroller with a flexible memory structure, programmable logic, and a rich peripheral mix to form an ideal embedded controller. At its core is a fast 4-cycle 8032 MCU with a 4-byte instruction prefetch queue (PFQ) and a 4-entry fully associative branching cache (BC). The MCU is connected to a 16-bit internal instruction path to maximize performance, enabling loops of code in smaller localities to execute extremely fast. The 16-bit wide instruction path in the *Turbo Plus* Series allows double-byte instructions to be fetched from memory in a single memory cycle. This keeps the average performance near its peak performance (peak performance for 5 V, 40 MHz *Turbo Plus* UPSD34xx is 10 MIPS for single-byte instructions, and average performance will be approximately 9 MIPS for mix of single- and multi-byte instructions).

USB 2.0 (full speed, 12Mbps) is included, providing 10 endpoints, each with its own 64-byte FIFO to maintain high data throughput. Endpoint 0 (control endpoint) uses two of the 10 endpoints for In and Out directions, the remaining eight endpoints may be allocated in any mix to either type of transfers: Bulk or Interrupt.

Code development is easily managed without a hardware in-circuit emulator by using the serial JTAG debug interface. JTAG is also used for in-system programming (ISP) in as little as 10 seconds, perfect for manufacturing and lab development. The 8032 core is coupled to programmable system device (PSD) architecture to optimize the 8032 memory structure, offering two independent banks of Flash memory that can be placed at virtually any address within 8032 program or data address space, and easily paged beyond 64 Kbytes using on-chip programmable decode logic.

Dual Flash memory banks provide a robust solution for remote product updates in the field through in-application programming (IAP). Dual Flash banks also support EEPROM emulation, eliminating the need for external EEPROM chips.

General-purpose programmable logic (PLD) is included to build an endless variety of glue-logic, saving external logic devices. The PLD is configured using the software development tool, PSDsoft Express, available from the web at www.st.com/psm, at no charge.

The UPSD34xx also includes supervisor functions such as a programmable watchdog timer and low-voltage reset.

Note: For a list of known limitations of the UPSD34xx devices, please refer to [Section 34: Important notes](#).

Figure 1. Block diagram

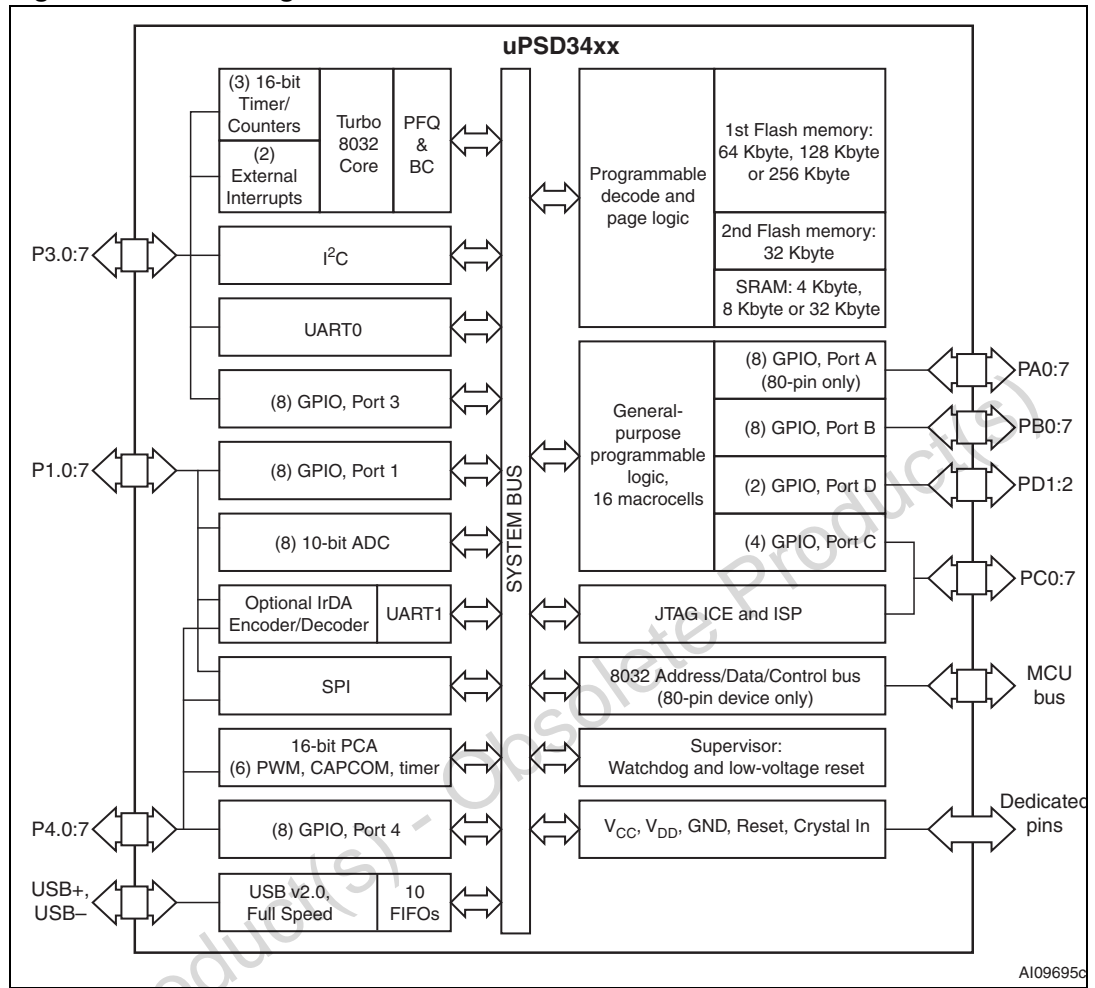

Obsolete Product(s)
 Obsolete Product(s)

2 Pin descriptions

Figure 2. LQFP52 connections

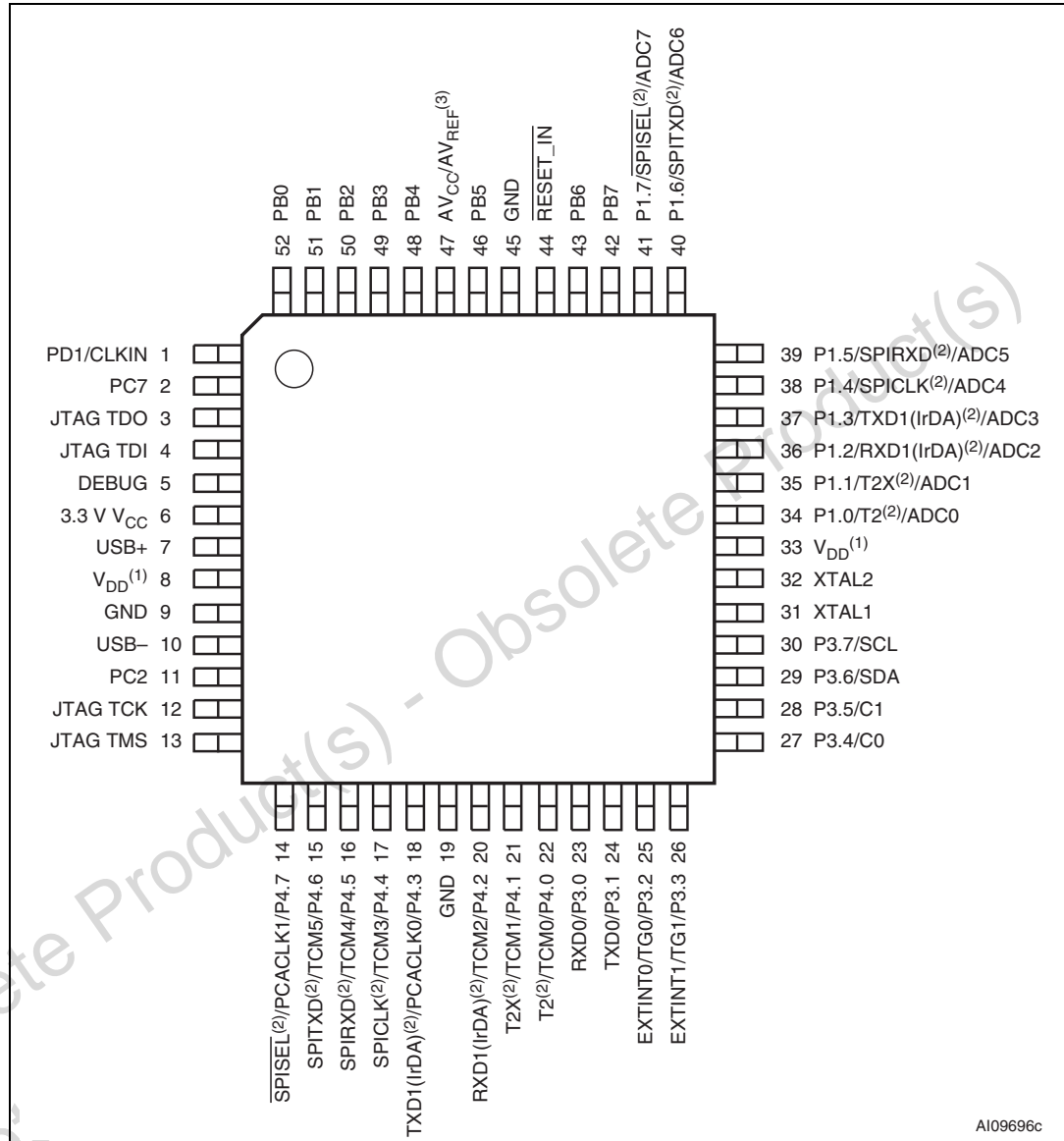

AI09696c

1. For 5 V applications, V_{DD} must be connected to a 5.0 V source. For 3.3 V applications, V_{DD} must be connected to a 3.3 V source.
2. These signals can be used on one of two different ports (Port 1 or Port 4) for flexibility. Default is Port1.
3. AV_{REF} and 3.3 V AV_{CC} are shared in the 52-pin package only. ADC channels must use 3.3 V as AV_{REF} for the 52-pin package.

Figure 3. LQFP80 connections

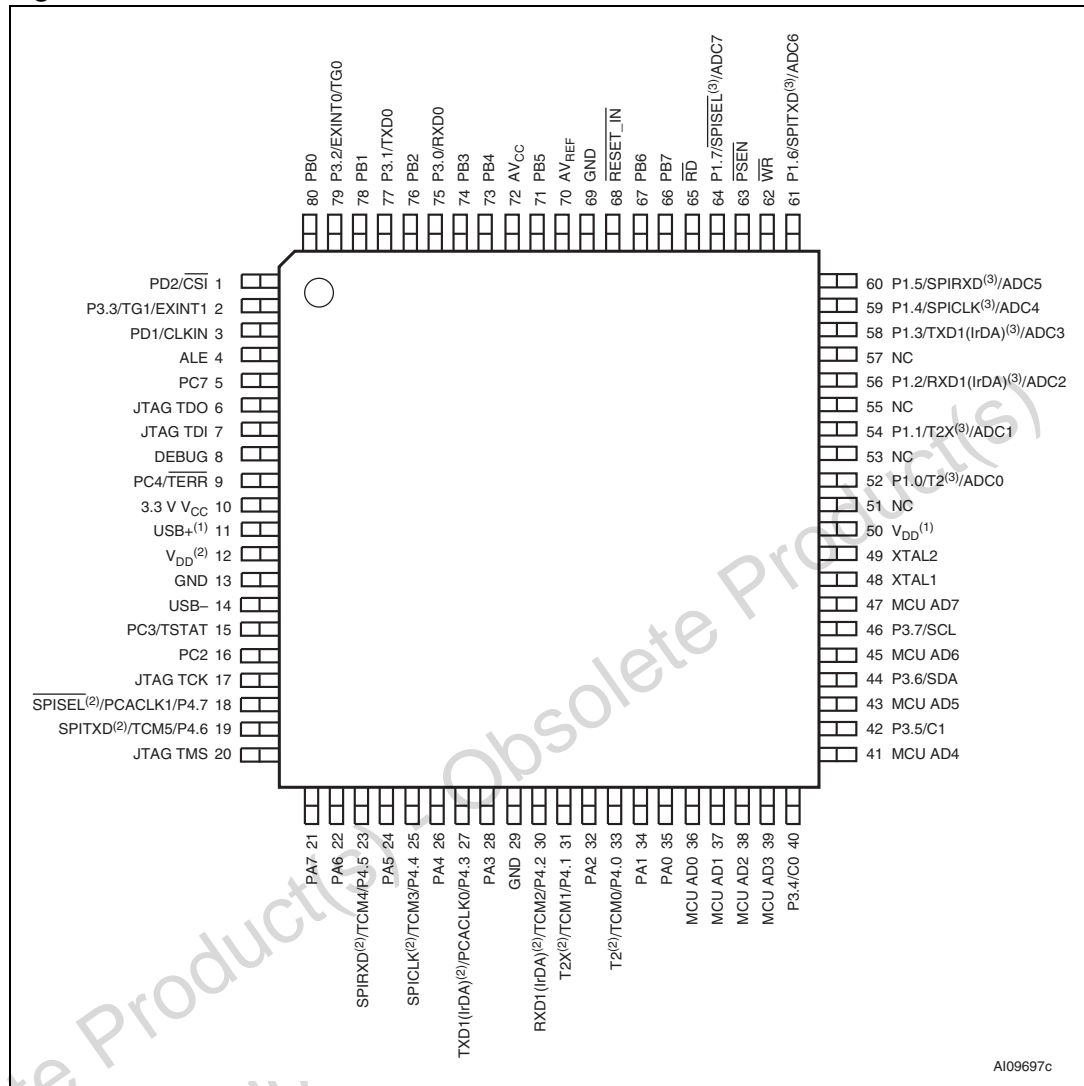

AI09697c

1. NC = Not connected
2. The USB+ pin needs a 1.5 kΩ pull-up resistor.
3. For 5 V applications, V_{DD} must be connected to a 5.0 V source. For 3.3 V applications, V_{DD} must be connected to a 3.3 V source.
4. These signals can be used on one of two different ports (Port 1 or Port 4) for flexibility. Default is Port1.

Table 2. Pin definitions

Port pin	Signal name	80-pin No.	52-pin No. ⁽¹⁾	In/out	Function		
					Basic	Alternate 1	Alternate 2
MCUAD0	AD0	36	N/A	I/O	External bus multiplexed address/data bus A0/D0		
MCUAD1	AD1	37	N/A	I/O	Multiplexed address/data bus A1/D1		
MCUAD2	AD2	38	N/A	I/O	Multiplexed address/data bus A2/D2		
MCUAD3	AD3	39	N/A	I/O	Multiplexed address/data bus A3/D3		
MCUAD4	AD4	41	N/A	I/O	Multiplexed address/data bus A4/D4		
MCUAD5	AD5	43	N/A	I/O	Multiplexed address/data bus A5/D5		
MCUAD6	AD6	45	N/A	I/O	Multiplexed address/data bus A6/D6		
MCUAD7	AD7	47	N/A	I/O	Multiplexed address/data bus A7/D7		
P1.0	T2 ADC0	52	34	I/O	General I/O port pin	Timer 2 Count input (T2)	ADC Channel 0 input (ADC0)
P1.1	T2X ADC1	54	35	I/O	General I/O port pin	Timer 2 Trigger input (T2X)	ADC Channel 1 input (ADC1)
P1.2	RxD1 ADC2	56	36	I/O	General I/O port pin	UART1 or IrDA Receive (RxD1)	ADC Channel 2 input (ADC2)
P1.3	TxD1 ADC3	58	37	I/O	General I/O port pin	UART or IrDA Transmit (TxD1)	ADC Channel 3 input (ADC3)
P1.4	SPICLK ADC4	59	38	I/O	General I/O port pin	SPI Clock Out (SPICLK)	ADC Channel 4 input (ADC4)
P1.5	SPIRxD ADC5	60	39	I/O	General I/O port pin	SPI Receive (SPIRxD)	ADC Channel 5 input (ADC5)
P1.6	SPITxD ADC6	61	40	I/O	General I/O port pin	SPI Transmit (SPITxD)	ADC Channel 6 input (ADC6)
P1.7	SPISEL ADC7	64	41	I/O	General I/O port pin	SPI Slave Select (SPISEL)	ADC Channel 7 input (ADC7)
P3.0	RxD0	75	23	I/O	General I/O port pin	UART0 Receive (RxD0)	

Table 2. Pin definitions (continued)

Port pin	Signal name	80-pin No.	52-pin No. ⁽¹⁾	In/out	Function		
					Basic	Alternate 1	Alternate 2
P3.1	TXD0	77	24	I/O	General I/O port pin	UART0 Transmit (TxD0)	
P3.2	EXINT0 TGO	79	25	I/O	General I/O port pin	Interrupt 0 input (EXTINT0)/Timer 0 gate control (TG0)	
P3.3	INT1	2	26	I/O	General I/O port pin	Interrupt 1 input (EXTINT1)/Timer 1 gate control (TG1)	
P3.4	C0	40	27	I/O	General I/O port pin	Counter 0 input (C0)	
P3.5	C1	42	28	I/O	General I/O port pin	Counter 1 input (C1)	
P3.6	SDA	44	29	I/O	General I/O port pin	I ² C bus serial data (I ² CSDA)	
P3.7	SCL	46	30	I/O	General I/O port pin	I ² C bus clock (I ² CSCL)	
P4.0	T2 TCM0	33	22	I/O	General I/O port pin	Program counter array0 PCA0-TCM0	Timer 2 count input (T2)
P4.1	T2X TCM1	31	21	I/O	General I/O port pin	PCA0-TCM1	Timer 2 trigger input (T2X)
P4.2	RXD1 TCM2	30	20	I/O	General I/O port pin	PCA0-TCM2	UART1 or IrDA Receive (RxD1)
P4.3	TXD1 PCACLK0	27	18	I/O	General I/O port pin	PCACLK0	UART1 or IrDA Transmit (TxD1)
P4.4	SPICLK TCM3	25	17	I/O	General I/O port pin	Program counter Array1 PCA1-TCM3	SPI clock out (SPICLK)
P4.5	SPIRXD TCM4	23	16	I/O	General I/O port pin	PCA1-TCM4	SPI Receive (SPIRXD)
P4.6	SPITXD	19	15	I/O	General I/O port pin	PCA1-TCM5	SPI Transmit (SPITXD)
P4.7	SPISEL PCACLK1	18	14	I/O	General I/O port pin	PCACLK1	SPI Slave Select (SPISEL)
AV _{REF}		70	N/A	I	Reference Voltage input for ADC. Connect AV _{REF} to V _{CC} if the ADC is not used.		
RD		65	N/A	O	READ signal, external bus		
WR		62	N/A	O	WRITE signal, external bus		
PSEN		63	N/A	O	PSEN signal, external bus		

Table 2. Pin definitions (continued)

Port pin	Signal name	80-pin No.	52-pin No. ⁽¹⁾	In/out	Function		
					Basic	Alternate 1	Alternate 2
ALE		4	N/A	O	Address Latch signal, external bus		
RESET_IN		68	44	I	Active low reset input		
XTAL1		48	31	I	Oscillator input pin for system clock		
XTAL2		49	32	O	Oscillator output pin for system clock		
DEBUG		8	5	I/O	I/O to the MCU debug unit		
PA0		35	N/A	I/O	General I/O port pin		All Port A pins support: – PLD Macrocell outputs, or – PLD inputs, or – Latched address out (A0-A7), or – Peripheral I/O mode
PA1		34	N/A	I/O	General I/O port pin		
PA2		32	N/A	I/O	General I/O port pin		
PA3		28	N/A	I/O	General I/O port pin		
PA4		26	N/A	I/O	General I/O port pin		
PA5		24	N/A	I/O	General I/O port pin		
PA6		22	N/A	I/O	General I/O port pin		
PA7		21	N/A	I/O	General I/O port pin		
PB0		80	52	I/O	General I/O port pin		All Port B pins support: – PLD Macrocell outputs, or – PLD inputs, or – Latched address out (A0-A7 or A8-A15)
PB1		78	51	I/O	General I/O port pin		
PB2		76	50	I/O	General I/O port pin		
PB3		74	49	I/O	General I/O port pin		
PB4		73	48	I/O	General I/O port pin		
PB5		71	46	I/O	General I/O port pin		
PB6		67	43	I/O	General I/O port pin		
PB7		66	42	I/O	General I/O port pin		
JTAGTMS	TMS	20	13	I	JTAG pin (TMS)		
JTAGTCK	TCK	17	12	I	JTAG pin (TCK)		
PC2		16	11	I/O	General I/O port pin		PLD Macrocell output, or PLD input
PC3	TSTAT	15	N/A	I/O	General I/O port pin	Optional JTAG Status (TSTAT)	PLD, Macrocell output, or PLD input
PC4	TERR	9	N/A	I/O	General I/O port pin	Optional JTAG Status (TERR)	PLD, Macrocell output, or PLD input
JTAGTDI	TDI	7	4	I	JTAG pin (TDI)		
JTAGTDO	TDO	6	3	O	JTAG pin (TDO)		

Table 2. Pin definitions (continued)

Port pin	Signal name	80-pin No.	52-pin No. ⁽¹⁾	In/out	Function		
					Basic	Alternate 1	Alternate 2
PC7		5	2	I/O	General I/O port pin		PLD, Macrocell output, or PLD input
PD1	CLKIN	3	1	I/O	General I/O port pin		– PLD I/O – Clock input to PLD and APD
PD2	CSI	1	N/A	I/O	General I/O port pin		– PLD I/O – Chip select of PSD module
USB+		11	7	I/O	USB D+ pin; 1.5 kΩ pull-up resistor is required.		
USB-		14	10	I/O	USB D- pin		
3.3 V-V _{CC}		10	6		V _{CC} - MCU module. connect AV _{CC} to V _{CC} if the ADC is not used.		
AV _{CC}		72	47		Analog VCC Input		
V _{DD} 3.3 V or 5 V		12	8		V _{DD} - PSD module V _{DD} - 3.3 V for 3 V V _{DD} - 5 V for 5 V		
V _{DD} 3.3 V or 5 V		50	33		V _{DD} - PSD module V _{DD} - 3.3 V for 3 V V _{DD} - 5 V for 5 V		
GND		13	9				
GND		29	19				
GND		69	45				
NC		51	N/A				
NC		53	N/A				
NC		55	N/A				
NC		57	N/A				

1. N/A = Signal not available on 52-pin package.

3 Hardware description

The UPSD34xx has a modular architecture built from a stacked die process. There are two dice, one is designated “MCU module” in this document, and the other is designated “PSD module” (see [Figure 4 on page 29](#)). In all cases, the MCU module die operates at 3.3 V with 5 V tolerant I/O. The PSD module is either a 3.3 V die or a 5 V die, depending on the UPSD34xx device as described below.

The MCU module consists of a fast 8032 core, that operates with 4 clocks per instruction cycle, and has many peripheral and system supervisor functions. The PSD module provides the 8032 with multiple memories (two Flash and one SRAM) for program and data, programmable logic for address decoding and for general-purpose logic, and additional I/O. The MCU module communicates with the PSD module through internal address and data busses (AD0 – AD15) and control signals (\overline{RD} , \overline{WR} , \overline{PSEN} , ALE, \overline{RESET}).

There are slightly different I/O characteristics for each module. I/Os for the MCU module are designated as Ports 1, 3, and 4. I/Os for the PSD module are designated as Ports A, B, C, and D.

For all 5 V UPSD34xx devices, a 3.3 V MCU module is stacked with a 5 V PSD module. In this case, a 5 V UPSD34xx device must be supplied with 3.3 V_{CC} for the MCU module and 5.0 V_{DD} for the PSD module. Ports 3 and 4 of the MCU module are 3.3 V ports with tolerance to 5 V devices (they can be directly driven by external 5 V devices and they can directly drive external 5 V devices while producing a V_{OH} of 2.4V min and V_{CC} max). Ports A, B, C, and D of the PSD module are true 5 V ports.

For all 3.3 V UPSD34xxV devices, a 3.3 V MCU module is stacked with a 3.3 V PSD module. In this case, a 3.3 V UPSD34xx device needs to be supplied with a single 3.3 V voltage source at both V_{CC} and V_{DD}. I/O pins on Ports 3 and 4 are 5 V tolerant and can be connected to external 5 V peripheral devices if desired. Ports A, B, C, and D of the PSD module are 3.3 V ports, which are not tolerant to external 5 V devices.

Refer to [Table 3](#) for port type and voltage source requirements.

80-pin UPSD34xx devices provide access to 8032 address, data, and control signals on external pins to connect external peripheral and memory devices. 52-pin UPSD34xx devices do not provide access to the 8032 system bus.

All non-volatile memory and configuration portions of the UPSD34xx device are programmed through the JTAG interface and no special programming voltage is needed. This same JTAG port is also used for debugging of the 8032 core at runtime providing breakpoint, single-step, display, and trace features. A non-volatile security bit may be programmed to block all access via JTAG interface for security. The security bit is defeated only by erasing the entire device, leaving the device blank and ready to use again.

Table 3. Port type and voltage source combinations

Device type	V _{CC} for MCU module	V _{DD} for PSD module	Ports 1, 3, and 4 on MCU module	Ports A, B, C, and D on PSD module
5 V: UPSD34xx	3.3 V	5.0 V	3.3 V (Ports 3 and 4 are 5 V tolerant)	5 V
3.3 V: UPSD34xxV	3.3 V	3.3 V	3.3 V (Ports 3 and 4 are 5 V tolerant)	3.3 V. NOT 5 V tolerant

Figure 4. Functional modules

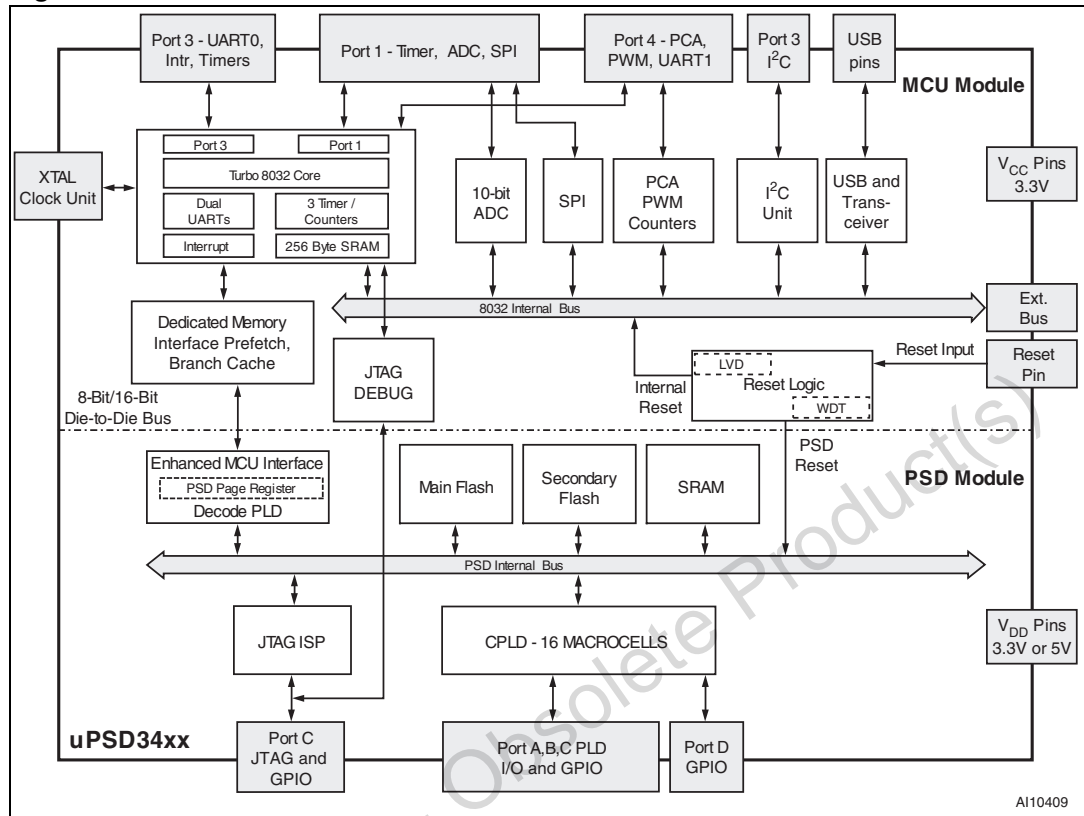

Obsolete Product(s) - Obsolete Product(s)

4 Memory organization

The 8032 MCU core views memory on the MCU module as “internal” memory and it views memory on the PSD module as “external” memory, see [Figure 5](#)

Internal memory on the MCU module consists of DATA, IDATA, and SFRs. These standard 8032 memories reside in 384 bytes of SRAM located at a fixed address space starting at address 0000h.

External memory on the PSD module consists of four types: main Flash (64 Kbyte, 128 Kbyte, or 256 Kbyte), a smaller secondary Flash (32 Kbyte), SRAM (4 Kbyte, 8 Kbyte or 32 Kbyte), and a block of PSD module control registers called csiop (256 bytes). These external memories reside at programmable address ranges, specified using the software tool PSDsoft Express. See the PSD module section of this document for more details on these memories.

External memory is accessed by the 8032 in two separate 64 Kbyte address spaces. One address space is for program memory and the other address space is for data memory. Program memory is accessed using the 8032 signal, \overline{PSEN} . Data memory is accessed using the 8032 signals, \overline{RD} and \overline{WR} . If the 8032 needs to access more than 64 Kbytes of external program or data memory, it must use paging (or banking) techniques provided by the page register in the PSD module.

Note: When referencing program and data memory spaces, it has nothing to do with 8032 internal SRAM areas of DATA, IDATA, and SFR on the MCU module. Program and data memory spaces only relate to the external memories on the PSD module.

External memory on the PSD module can overlap the internal SRAM memory on the MCU module in the same physical address range (starting at 0000h) without interference because the 8032 core does not assert the \overline{RD} or \overline{WR} signals when accessing internal SRAM.

Figure 5. UPSD34xx memories

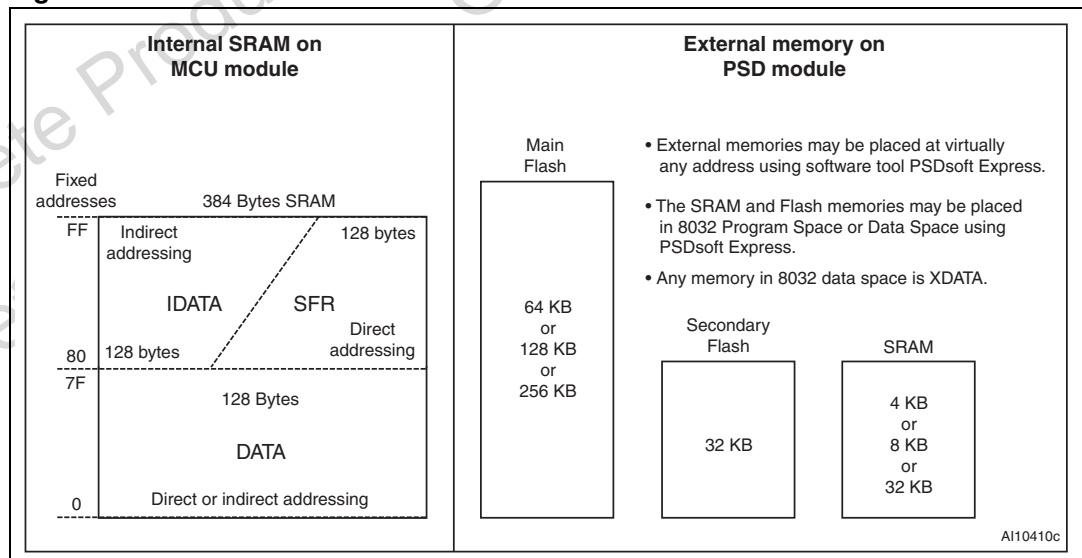

4.1 Internal memory (MCU module, standard 8032 memory: DATA, IDATA, SFR)

4.1.1 DATA memory

The first 128 bytes of internal SRAM ranging from address 0000h to 007Fh are called DATA, which can be accessed using 8032 **direct or indirect** addressing schemes and are typically used to store variables and stack.

Four register banks, each with 8 registers (R0 – R7), occupy addresses 0000h to 001Fh. Only one of these four banks may be enabled at a time. The next 16 locations at 0020h to 002Fh contain 128 directly addressable bit locations that can be used as software flags. SRAM locations 0030h and above may be used for variables and stack.

4.1.2 IDATA memory

The next 128 bytes of internal SRAM are named IDATA and range from address 0080h to 00FFh. IDATA can be accessed only through 8032 **indirect addressing** and is typically used to hold the MCU stack as well as data variables. The stack can reside in both DATA and IDATA memories and reach a size limited only by the available space in the combined 256 bytes of these two memories (since stack accesses are always done using indirect addressing, the boundary between DATA and IDATA does not exist with regard to the stack).

4.1.3 SFR memory

Special function registers ([Table 5 on page 42](#)) occupy a separate physical memory, but they logically overlap the same 128 bytes as IDATA, ranging from address 0080h to 00FFh. SFRs are accessed only using **direct addressing**. There are 86 active registers used for many functions: changing the operating mode of the 8032 MCU core, controlling 8032 peripherals, controlling I/O, and managing interrupt functions. The remaining unused SFRs are reserved and should not be accessed.

16 of the SFRs are both byte- and bit-addressable. Bit-addressable SFRs are those whose address ends in "0" or "8" hex.

4.2 External memory (PSD module: program memory, data memory)

The PSD module has four memories: main Flash, secondary Flash, SRAM, and csiop. See the PSD MODULE section for more detailed information on these memories.

Memory mapping in the PSD module is implemented with the Decode PLD (DPLD) and optionally the page register. The user specifies decode equations for individual segments of each of the memories using the software tool PSDsoft Express. This is a very easy point-and-click process allowing total flexibility in mapping memories. Additionally, each of the memories may be placed in various combinations of 8032 program address space or 8032 data address space by using the software tool PSDsoft Express.

4.2.1 Program memory

External program memory is addressed by the 8032 using its 16-bit program counter (PC) and is accessed with the 8032 signal, \overline{PSEN} . Program memory can be present at any address in program space between 0000h and FFFFh.

After a power-up or reset, the 8032 begins program execution from location 0000h where the reset vector is stored, causing a jump to an initialization routine in firmware. At address 0003h, just following the reset vector are the interrupt service locations. Each interrupt is assigned a fixed interrupt service location in program memory. An interrupt causes the 8032 to jump to that service location, where it commences execution of the service routine. External Interrupt 0 (EXINT0), for example, is assigned to service location 0003h. If EXINT0 is going to be used, its service routine must begin at location 0003h. Interrupt service locations are spaced at 8-byte intervals: 0003h for EXINT0, 000Bh for Timer 0, 0013h for EXINT1, and so forth. If an interrupt service routine is short enough, it can reside entirely within the 8-byte interval. Longer service routines can use a jump instruction to somewhere else in program memory.

4.2.2 Data memory

External data is referred to as XDATA and is addressed by the 8032 using Indirect Addressing via its 16-bit data pointer register (DPTR) and is accessed by the 8032 signals, \overline{RD} and \overline{WR} . XDATA can be present at any address in data space between 0000h and FFFFh.

Note: The UPSD34xx has dual data pointers (source and destination) making XDATA transfers much more efficient.

4.2.3 Memory placement

PSD module architecture allows the placement of its external memories into different combinations of program memory and data memory spaces. This means the main Flash, the secondary Flash, and the SRAM can be viewed by the 8032 MCU in various combinations of program memory or data memory as defined by PSDsoft Express.

As an example of this flexibility, for applications that require a great deal of Flash memory in data space (large lookup tables or extended data recording), the larger main Flash memory can be placed in data space and the smaller secondary Flash memory can be placed in program space. The opposite can be realized for a different application if more Flash memory is needed for code and less Flash memory for data.

By default, the SRAM and csiop memories on the PSD module must always reside in data memory space and they are treated by the 8032 as XDATA.

The main Flash and secondary Flash memories may reside in program space, data space, or both. These memory placement choices specified by PSDsoft Express are programmed into non-volatile sections of the UPSD34xx, and are active at power-up and after reset. It is possible to override these initial settings during runtime for In-Application Programming (IAP).

Standard 8032 MCU architecture cannot write to its own program memory space to prevent accidental corruption of firmware. However, this becomes an obstacle in typical 8032 systems when a remote update to firmware in Flash memory is required using IAP. The PSD module provides a solution for remote updates by allowing 8032 firmware to temporarily "reclassify" Flash memory to reside in data space during a remote update, then returning Flash memory back to program space when finished. See the VM register ([Table 160 on page 203](#)) in the PSD module section of this document for more details.

5 8032 MCU core performance enhancements

Before describing performance features of the UPSD34xx, let us first look at standard 8032 architecture. The clock source for the 8032 MCU creates a basic unit of timing called a machine-cycle, which is a period of 12 clocks for standard 8032 MCUs. The instruction set for traditional 8032 MCUs consists of 1, 2, and 3 byte instructions that execute in different combinations of 1, 2, or 4 machine-cycles. For example, there are one-byte instructions that execute in one machine-cycle (12 clocks), one-byte instructions that execute in four machine-cycles (48 clocks), two-byte, two-cycle instructions (24 clocks), and so on. In addition, standard 8032 architecture will fetch two bytes from program memory on almost every machine-cycle, regardless if it needs them or not (dummy fetch). This means for one-byte, one-cycle instructions, the second byte is ignored. These one-byte, one-cycle instructions account for half of the 8032's instructions (126 out of 255 opcodes). There are inefficiencies due to wasted bus cycles and idle bus times that can be eliminated.

The UPSD34xx 8032 MCU core offers increased performance in a number of ways, while keeping the exact same instruction set as the standard 8032 (all opcodes, the number of bytes per instruction, and the native number a machine-cycles per instruction are identical to the original 8032). The first way performance is boosted is by reducing the machine-cycle period to just 4 MCU clocks as compared to 12 MCU clocks in a standard 8032. This shortened machine-cycle improves the instruction rate for one- or two-byte, one-cycle instructions by a factor of three (*Figure 6 on page 33*) compared to standard 8051 architectures, and significantly improves performance of multiple-cycle instruction types.

The example in *Figure 6 on page 33* shows a continuous execution stream of one- or two-byte, one-cycle instructions. The 5 V UPSD34xx will yield 10 MIPS peak performance in this case while operating at 40 MHz clock rate. In a typical application however, the effective performance will be lower since programs do not use only one-cycle instructions, but special techniques are implemented in the UPSD34xx to keep the effective MIPS rate as close as possible to the peak MIPS rate at all times. This is accomplished with an instruction pre-fetch queue (PFQ), a branch cache (BC), and a 16-bit program memory bus as shown in *Figure 7 on page 34*.

Figure 6. Comparison of UPSD34xx with standard 8032 performance

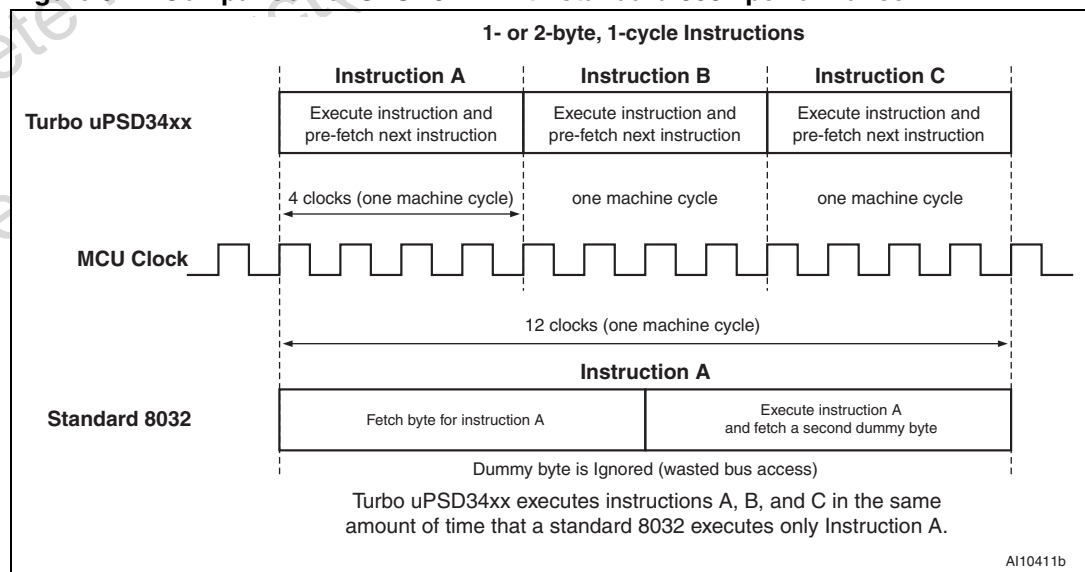
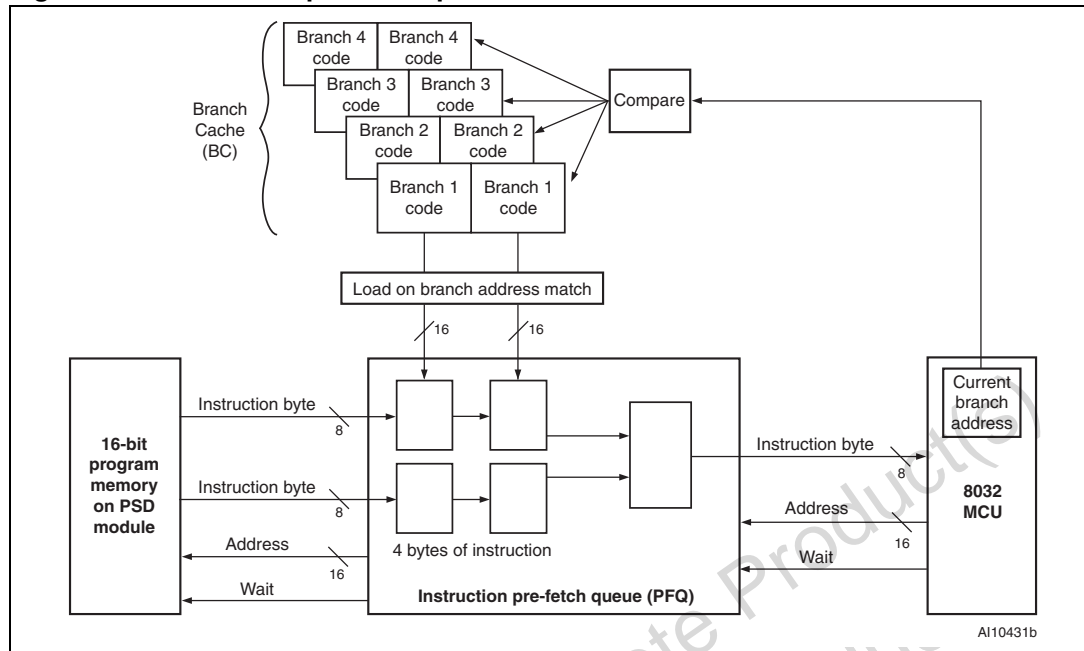

Figure 7. Instruction pre-fetch queue and branch cache



5.1 Pre-fetch queue (PFQ) and branch cache (BC)

The PFQ is always working to minimize the idle bus time inherent to 8032 MCU architecture, to eliminate wasted memory fetches, and to maximize memory bandwidth to the MCU. The PFQ does this by running asynchronously in relation to the MCU, looking ahead to pre-fetch two bytes (word) of code from program memory during any idle bus periods. Only necessary word will be fetched (no dummy fetches like standard 8032). The PFQ will queue up to four code bytes in advance of execution, which significantly optimizes sequential program performance. However, when program execution becomes non-sequential (program branch), a typical pre-fetch queue will empty itself and reload new code, causing the MCU to stall. The Turbo UPSD34xx diminishes this problem by using a Branch Cache with the PFQ. The BC is a four-way, fully associative cache, meaning that when a program branch occurs, its branch destination address is compared simultaneously with four recent previous branch destinations stored in the BC. Each of the four cache entries contain up to four bytes of code related to a branch. If there is a hit (a match), then all four code bytes of the matching program branch are transferred immediately and simultaneously from the BC to the PFQ, and execution on that branch continues with minimal delay. This greatly reduces the chance that the MCU will stall from an empty PFQ, and improves performance in embedded control systems where it is quite common to branch and loop in relatively small code localities.

By default, the PFQ and BC are enabled after power-up or reset. The 8032 can disable the PFQ and BC at runtime if desired by writing to a specific SFR (BUSCON).

The memory in the PSD module operates with variable wait states depending on the value specified in the SFR named BUSCON. For example, a 5 V UPSD34xx device operating at a 40 MHz crystal frequency requires four memory wait states (equal to four MCU clocks). In this example, once the PFQ has one word of code, the wait states become transparent and a full 10 MIPS is achieved when the program stream consists of sequential one- or two-byte, one machine-cycle instructions as shown in [Figure 6 on page 33](#) (transparent because a machine-cycle is four MCU clocks which equals the memory pre-fetch wait time that is also

four MCU clocks). But it is also important to understand PFQ operation on multi-cycle instructions.

5.2 PFQ example, multi-cycle instructions

Let us look at a string of two-byte, two-cycle instructions in *Figure 8 on page 35*. There are three instructions executed sequentially in this example, instructions A, B, and C. Each of the time divisions in the figure is one machine-cycle of four clocks, and there are six phases to reference in this discussion. Each instruction is pre-fetched into the PFQ in advance of execution by the MCU. Prior to Phase 1, the PFQ has pre-fetched the two instruction bytes (A1 and A2) of Instruction A. During Phase one, both bytes are loaded into the MCU execution unit. Also in Phase 1, the PFQ is pre-fetching Instruction B (bytes B1 and B2) from program memory. In Phase 2, the MCU is processing Instruction A internally while the PFQ is pre-fetching Instruction C. In Phase 3, both bytes of instruction B are loaded into the MCU execution unit and the PFQ begins to pre-fetch bytes for the next instruction. In Phase 4 Instruction B is processed.

The UPSD34xx MCU instructions are an exact 1/3 scale of all standard 8032 instructions with regard to number of cycles per instruction. *Figure 9 on page 36* shows the equivalent instruction sequence from the example above on a standard 8032 for comparison.

5.3 Aggregate performance

The stream of two-byte, two-cycle instructions in *Figure 8 on page 35*, running on a 40 MHz, 5 V, UPSD34xx will yield 5 MIPS. And we saw the stream of one- or two-byte, one-cycle instructions in *Figure 6 on page 33*, on the same MCU yield 10 MIPS. Effective performance will depend on a number of things: the MCU clock frequency; the mixture of instructions types (bytes and cycles) in the application; the amount of time an empty PFQ stalls the MCU (mix of instruction types and misses on Branch Cache); and the operating voltage. A 5 V UPSD34xx device operates with four memory wait states, but a 3.3 V device operates with five memory wait states yielding 8 MIPS peak compared to 10 MIPS peak for 5 V device. The same number of wait states will apply to both program fetches and to data READ/WRITEs unless otherwise specified in the SFR named BUSCON.

In general, a 3X aggregate performance increase is expected over any standard 8032 application running at the same clock frequency.

Figure 8. PFQ operation on multi-cycle instructions

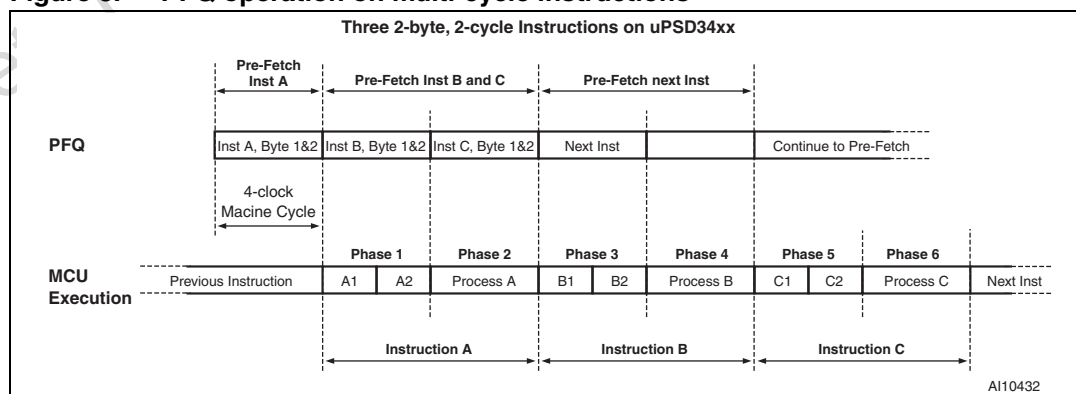
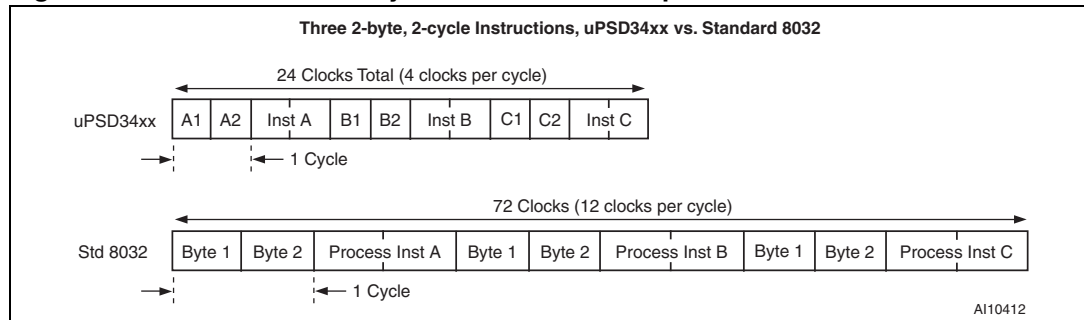

Figure 9. UPSD34xx multi-cycle instructions compared to standard 8032



Obsolete Product(s) - Obsolete Product(s)
Obsolete Product(s) - Obsolete Product(s)

6 MCU module description

The following sections provide a detailed description of the MCU module system functions and peripherals, including:

- 8032 MCU registers
- Special function registers
- 8032 addressing modes
- UPSD34xx instruction set summary
- Dual data pointers
- Debug unit
- Interrupt system
- MCU clock generation
- Power saving modes
- Oscillator and external components
- I/O ports
- MCU bus interface
- Supervisory functions
- Standard 8032 timer/counters
- Serial UART interfaces
- IrDA interface
- I²C interface
- SPI interface
- Analog to digital converter
- Programmable counter array (PCA)
- USB interface

7 8032 MCU registers

The UPSD34xx has the following 8032 MCU core registers, also shown in [Figure 10](#).

Figure 10. 8032 MCU registers

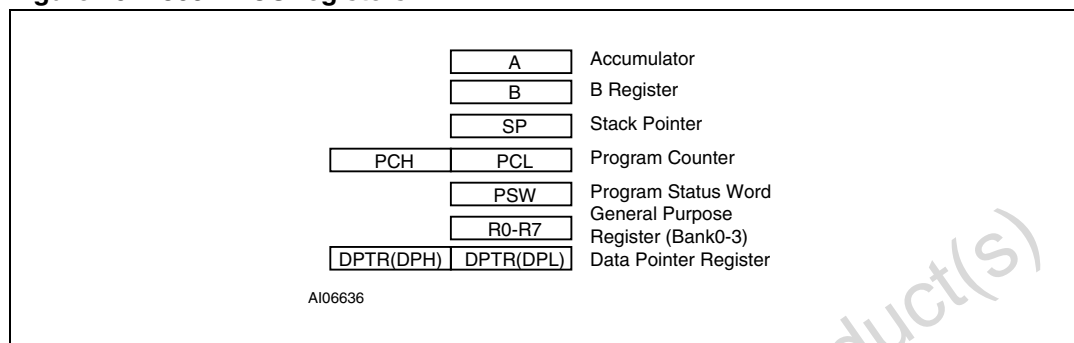

7.1 Stack pointer (SP)

The SP is an 8-bit register which holds the current location of the top of the stack. It is incremented before a value is pushed onto the stack, and decremented after a value is popped off the stack. The SP is initialized to 07h after reset. This causes the stack to begin at location 08h (top of stack). To avoid overlapping conflicts, the user must initialize the top of the stack to 20h if all four banks of registers R0 - R7 are used, as well as the top of stack to 30h if all of the 8032 bit memory locations are used.

7.2 Data pointer (DPTR)

DPTR is a 16-bit register consisting of two 8-bit registers, DPL and DPH. The DPTR register is used as a base register to create an address for indirect jumps, table look-up operations, and for external data transfers (XDATA). When not used for addressing, the DPTR register can be used as a general purpose 16-bit data register.

Very frequently, the DPTR register is used to access XDATA using the external direct addressing mode. The UPSD34xx has a special set of SFR registers (DPTC, DPTM) to control a secondary DPTR register to speed memory-to-memory XDATA transfers. Having dual DPTR registers allows rapid switching between source and destination addresses (see details in [Section 11: Dual data pointers on page 57](#)).

7.3 Program counter (PC)

The PC is a 16-bit register consisting of two 8-bit registers, PCL and PCH. This counter indicates the address of the next instruction in program memory to be fetched and executed. A reset forces the PC to location 0000h, which is where the reset jump vector is stored.

7.4 Accumulator (ACC)

This is an 8-bit general purpose register which holds a source operand and receives the result of arithmetic operations. The ACC register can also be the source or destination of logic and data movement operations. For MUL and DIV instructions, ACC is combined with the B register to hold 16-bit operands. The ACC is referred to as “A” in the MCU instruction set.

7.5 B register (B)

The B register is a general purpose 8-bit register for temporary data storage and also used as a 16-bit register when concatenated with the ACC register for use with MUL and DIV instructions.

7.6 General purpose registers (R0 - R7)

There are four banks of eight general purpose 8-bit registers (R0 - R7), but only one bank of eight registers is active at any given time depending on the setting in the PSW word (described next). R0 - R7 are generally used to assist in manipulating values and moving data from one memory location to another. These register banks physically reside in the first 32 locations of 8032 internal DATA SRAM, starting at address 00h. At reset, only the first bank of eight registers is active (addresses 00h to 07h), and the stack begins at address 08h.

7.7 Program status word (PSW)

The PSW is an 8-bit register which stores several important bits, or flags, that are set and cleared by many 8032 instructions, reflecting the current state of the MCU core. [Figure 11 on page 40](#) shows the individual flags.

7.7.1 Carry flag (CY)

This flag is set when the last arithmetic operation that was executed results in a carry (addition) or borrow (subtraction). It is cleared by all other arithmetic operations. The CY flag is also affected by Shift and Rotate Instructions.

7.7.2 Auxiliary carry flag (AC)

This flag is set when the last arithmetic operation that was executed results in a carry into (addition) or borrow from (subtraction) the high-order nibble. It is cleared by all other arithmetic operations.

7.7.3 General purpose flag (F0)

This is a bit-addressable, general-purpose flag for use under software control.

7.7.4 Register bank select flags (RS1, RS0)

These bits select which bank of eight registers is used during R0 - R7 register accesses (see [Table 4](#))

7.7.5 Overflow flag (OV)

The OV flag is set when: an ADD, ADDC, or SUBB instruction causes a sign change; a MUL instruction results in an overflow (result greater than 255); a DIV instruction causes a divide-by-zero condition. The OV flag is cleared by the ADD, ADDC, SUBB, MUL, and DIV instructions in all other cases. The CLRV instruction will clear the OV flag at any time.

7.7.6 Parity flag (P)

The P flag is set if the sum of the eight bits in the Accumulator is odd, and P is cleared if the sum is even.

Table 4. Register bank select addresses

RS1	RS0	Register bank	8032 internal data address
0	0	0	00h - 07h
0	1	1	08h - 0Fh
1	0	2	10h - 17h
1	1	3	18h - 1Fh

Figure 11. Program status word (PSW) register

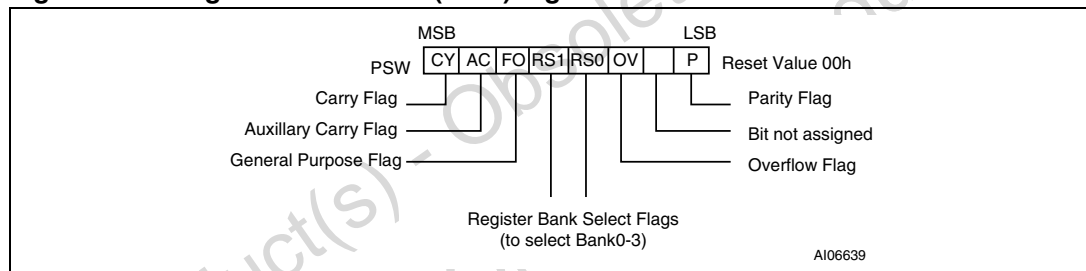

8 Special function registers (SFR)

A group of registers designated as special function register (SFR) is shown in [Table 5 on page 42](#). SFRs control the operating modes of the MCU core and also control the peripheral interfaces and I/O pins on the MCU module. The SFRs can be accessed only by using the Direct Addressing method within the address range from 80h to FFh of internal 8032 SRAM. Sixteen addresses in SFR address space are both byte- and bit-addressable. The bit-addressable SFRs are noted in [Table 5](#).

106 of a possible 128 SFR addresses are occupied. The remaining unoccupied SFR addresses (designated as “RESERVED” in [Table 5](#)) should not be written. Reading unoccupied locations will return an undefined value.

Note: There is a separate set of control registers for the PSD module, designated as *csiop*, and they are described in the [Section 28: PSD module on page 191](#). The I/O pins, *PLD*, and other functions on the PSD module are NOT controlled by SFRs.

SFRs are categorized as follows:

- MCU core registers:
IP, A, B, PSW, SP, DPTL, DPTH, DPTC, DPTM
- MCU module I/O Port registers:
P1, P3, P4, P1SFS0, P1SFS1, P3SFS, P4SFS0, P4SFS1
- Standard 8032 Timer registers
TCON, TMOD, T2CON, TH0, TH1, TH2, TL0, TL1, TL2, RCAP2L, RCAP2H
- Standard Serial Interfaces (UART)
SCON0, SBUF0, SCON1, SBUF1
- Power, clock, and bus timing registers
PCON, CCON0, CCON1, BUSCON
- Hardware watchdog timer registers
WDKEY, WDRST
- Interrupt system registers
IP, IPA, IE, IEA
- Prog. Counter Array (PCA) control registers
PCACL0, PCACH0, PCACON0, PCASTA, PCACL1, PCACH1, PCACON1, CCON2, CCON3
- PCA capture/compare and PWM registers
CAPCOML0, CAPCOMH0, TCMODE0, CAPCOML1, CAPCOMH1, TCMODE2, CAPCOML2, CAPCOMH2, TCMODE2, CAPCOML3, CAPCOMH3, TCMODE3,

CAPCOML4, CAPCOMH4, TCMODE4, CAPCOML5, CAPCOMH5, TCMODE5, PWMF0, PMWF1

- SPI interface registers
SPICLKD, SPISTAT, SPITDR, SPIRDR, SPICON0, SPICON1
- I²C interface registers
S1SETUP, S1CON, S1STA, S1DAT, S1ADR
- Analog to digital converter registers
ACON, ADCPS, ADAT0, ADAT1
- IrDA interface register
IRDACON
- USB interface registers
UADDR, UPAIR, WE0-3, UIF0-3, UCTL, USTA, USEL, UCON, USEZ, UBASEH, UBASEL, USCI, USCV

Table 5. SFR memory map with direct address and reset value

SFR addr (hex)	SFR name	Bit name and <bit address>								Reset value (hex)	Reg. descr. with link
		7	6	5	4	3	2	1	0		
80		RESERVED									
81	SP	SP[7:0]								07	Section 7.1
82	DPL	DPL[7:0]								00	Section 7.2
83	DPH	DPH[7:0]								00	
84		RESERVED									
85	DPTC	-	AT	-	-	-	DPSEL[2:0]			00	Table 13
86	DPTM	-	-	-	-	MD1[1:0]		MD0[1:0]		00	Table 15
87	PCON	SMOD0	SMOD1	-	POR	RCLK1	TCLK1	PD	IDLE	00	Table 33
88 ⁽¹⁾	TCON	TF1 <8Fh>	TR1 <8Eh>	TF0 <8Dh>	TR0 <8Ch>	IE1 <8Bh>	IT1 <8Ah>	IE0 <89h>	IT0 <88h>	00	Table 56
89	TMOD	GATE	C/T	M1	M0	GATE	C/T	M1	M0	00	Table 58
8A	TL0	TL0[7:0]								00	Section 20.1
8B	TL1	TL1[7:0]								00	
8C	TH0	TH0[7:0]								00	
8D	TH1	TH1[7:0]								00	
8E	P1SFS0	P1SFS0[7:0]								00	Table 43
8F	P1SFS1	P1SFS1[7:0]								00	Table 44
90 ⁽¹⁾	P1	P1.7 <97h>	P1.6 <96h>	P1.5 <95h>	P1.4 <94h>	P1.3 <93h>	P1.2 <92h>	P1.1 <91h>	P1.0 <90h>	FF	Table 35
91	P3SFS	P3SFS[7:0]								00	Table 41
92	P4SFS0	P4SFS0[7:0]								00	Table 46
93	P4SFS1	P4SFS1[7:0]								00	Table 47

Table 5. SFR memory map with direct address and reset value (continued)

SFR addr (hex)	SFR name	Bit name and <bit address>								Reset value (hex)	Reg. descr. with link
		7	6	5	4	3	2	1	0		
94	ADCPS	-	-	-	-	ADCCE	ADCPS[2:0]			00	Table 140
95	ADAT0	ADATA[7:0]								00	Table 141
96	ADAT1	-	-	-	-	-	-	ADATA[9:8]		00	Table 142
97	ACON	AINTF	AINTEN	ADEN	ADS[2:0]			ADST	ADSF	00	Table 138
98 ⁽¹⁾	SCON0	SM0 <9Fh>	SM1 <9Eh>	SM2 <9Dh>	REN <9Ch>	TB8 <9Bh>	RB8 <9Ah>	TI <99h>	RI <9h8>	00	Table 65
99	SBUF0	SBUF0[7:0]								00	Section 21
9A	RESERVED										
9B	RESERVED										
9C	RESERVED										
9D	BUSCON	EPFQ	EBC	WRW1	WRW0	RDW1	RDW0	CW1	CW0	EB	Table 49
9E	RESERVED										
9F	RESERVED										
A0	RESERVED										
A1	RESERVED										
A2	PCACL0	PCACL0[7:0]								00	Table 143
A3	PCACH0	PCACH0[7:0]								00	Table 143
A4	PCACON0	EN_ALL	EN_PCA	EOVF1	PCA_IDL	-	-	CLK_SEL[1:0]		00	Table 148
A5	PCASTA	OVF1	INTF5	INTF4	INTF3	OVF0	INTF2	INTF1	INTF0	00	Table 152
A6	WDRST	WDRST[7:0]								00	Table 54
A7	IEA	EADC	ESPI	EPCA	ES1	-	-	EI2C	-	00	Table 20
A8 ⁽¹⁾	IE	EA <AFh>	-	ET2 <ADh>	ES0 <ACh>	ET1 <ABh>	EX1 <AAh>	ET0 <A9h>	EX0 <A8h>	00	Table 18
A9	TCMMODE0	EINTF	E_COMP	CAP_PE	CAP_NE	MATCH	TOGGLE	PWM[1:0]		00	Table 154
AA	TCMMODE1	EINTF	E_COMP	CAP_PE	CAP_NE	MATCH	TOGGLE	PWM[1:0]		00	
AB	TCMMODE2	EINTF	E_COMP	CAP_PE	CAP_NE	MATCH	TOGGLE	PWM[1:0]		00	
AC	CAPCOML0	CAPCOML0[7:0]								00	Table 143
AD	CAPCOMH0	CAPCOMH0[7:0]								00	
AE	WDKEY	WDKEY[7:0]								55	Table 52
AF	CAPCOML1	CAPCOML1[7:0]								00	Table 143

Table 5. SFR memory map with direct address and reset value (continued)

SFR addr (hex)	SFR name	Bit name and <bit address>								Reset value (hex)	Reg. descr. with link
		7	6	5	4	3	2	1	0		
B0 ⁽¹⁾	P3	P3.7 <B7h>	P3.6 <B6h>	P3.5 <B5h>	P3.4 <B4h>	P3.3 <B3h>	P3.2 <B2h>	P3.1 <B1h>	P3.0 <B0h>	FF	Table 37
B1	CAPCOM H1	CAPCOMH1[7:0]								00	Table 143
B2	CAPCOM L2	CAPCOML2[7:0]								00	
B3	CAPCOM H2	CAPCOMH2[7:0]								00	
B4	PWMF0	PWMF0[7:0]								00	
B5	RESERVED										
B6	RESERVED										
B7	IPA	PADC	PSPI	PPCA	PS1	–	–	PI2C	–	00	Table 24
B8 ⁽¹⁾	IP	–	–	PT2 <BDh>	PS0 <BCh>	PT1 <BBh>	PX1 <BAh>	PT0 <B9h>	PX0 <B8h>	00	Table 22
B9	RESERVED										
BA	PCACL1	PCACL1[7:0]								00	Table 143
BB	PCACH1	PCACH1[7:0]								00	
BC	PCACON1	–	EN_PCA	EOVF1	PCA_IDL	–	–	CLK_SEL[1:0]		00	Table 150
BD	TCMMOD E3	EINTF	E_COMP	CAP_PE	CAP_NE	MATCH	TOGGLE	PWM[1:0]		00	Table 154
BE	TCMMOD E4	EINTF	E_COMP	CAP_PE	CAP_NE	MATCH	TOGGLE	PWM[1:0]		00	
BF	TCMMOD E5	EINTF	E_COMP	CAP_PE	CAP_NE	MATCH	TOGGLE	PWM[1:0]		00	
C0 ⁽¹⁾	P4	P4.7 <C7h>	P4.6 <C6h>	P4.5 <C5h>	P4.4 <C4h>	P4.3 <C3h>	P4.2 <C2h>	P4.1 <C1h>	P4.0 <C0h>	FF	Table 39

Table 5. SFR memory map with direct address and reset value (continued)

SFR addr (hex)	SFR name	Bit name and <bit address>								Reset value (hex)	Reg. descr. with link
		7	6	5	4	3	2	1	0		
C1	CAPCOM L3	CAPCOML3[7:0]								00	Table 143
C2	CAPCOM H3	CAPCOMH3[7:0]								00	
C3	CAPCOM L4	CAPCOML4[7:0]								00	
C4	CAPCOM H4	CAPCOMH4[7:0]								00	
C5	CAPCOM L5	CAPCOML5[7:0]								00	
C6	CAPCOM H5	CAPCOMH5[7:0]								00	
C7	PWMF1	PWMF1[7:0]								00	
C8 ⁽¹⁾	T2CON	TF2 <CFh>	EXF2 <CEh>	RCLK <CDh>	TCLK <CCh>	EXEN2 <CBh>	TR2 <CAh>	C/T2 <C9h>	CP/RL2 <C8h>	00	Table 60
C9	RESERVED										
CA	RCAP2L	RCAP2L[7:0]								00	Section 20.1
CB	RCAP2H	RCAP2H[7:0]								00	
CC	TL2	TL2[7:0]								00	
CD	TH2	TH2[7:0]								00	
CE	IRDACON	-	IRDA_EN	BIT_PULS	CDIV4	CDIV3	CDIV2	CDIV1	CDIV0	0F	Table 70
D0 ⁽¹⁾	PSW	CY <D7h>	AC <D6h>	F0 <D5h>	RS[1:0] <D4h, D3h>		OV <D2h>	-	P <D0>	00	Section 7.7
D1	RESERVED										
D2	SPICKD	SPICKD[5:0]						-	-	04	Table 93
D3	SPISTAT	-	-	-	BUSY	TEISF	RORISF	TISF	RISF	02	Table 95
D4	SPITDR	SPITDR[7:0]								00	Table 91
D5	SPIRDR	SPIRDR[7:0]								00	
D6	SPICON0	-	TE	RE	SPIEN	SSEL	FLSB	SPO	-	00	Table 89
D7	SPICON1	-	-	-	-	TEIE	RORIE	TIE	RIE	00	Table 91
D8 ⁽¹⁾	SCON1	SM0 <DF>	SM1 <DE>	SM2 <DD>	REN <DC>	TB8 <DB>	RB8 <DA>	TI <D9>	RI <D8>	00	Table 67
D9	SBUF1	SBUF1[7:0]								00	Section 21
DA	RESERVED										
DB	S1SETUP	SS_EN	SMPL_SET[6:0]							00	Table 84
DC	S1CON	CR2	EN1	STA	STO	ADDR	AA	CR1	CR0	00	Table 75

Table 5. SFR memory map with direct address and reset value (continued)

SFR addr (hex)	SFR name	Bit name and <bit address>								Reset value (hex)	Reg. descr. with link
		7	6	5	4	3	2	1	0		
DD	S1STA	GC	STOP	INTR	TX_MD	B_BUSY	B_LOST	ACK_R	SLV	00	Table 78
DE	S1DAT	S1DAT[7:0]								00	Table 80
DF	S1ADR	S1ADR[7:0]								00	Table 82
E0 ⁽¹⁾	A	A[7:0] <bit addresses: E7h, E6h, E5h, E4h, E3h, E2h, E1h, E0h>								00	Section 7.4
E1	RESERVED										
E2	UADDR	–	USBADDR[6:0]							00	
E3	UPAIR	–	–	–	–	PR3OUT	PR1OUT	PR3IN	PR1IN	00	
E4	UIE0	–	–	–	–	RSTIE	SUSPNDIE	EOPIE	RESUMIE	00	
E5	UIE1	–	–	–	IN4IE	IN3IE	IN2IE	IN1IE	IN0IE	00	
E6	UIE2	–	–	–	OUT4IE	OUT3IE	OUT2IE	OUT1IE	OUT0IE	00	
E7	UIE3	–	–	–	NAK4IE	NAK3IE	NAK2IE	NAK1IE	NAK0IE	00	
E8	UIF0	GLF	INF	OUTF	NAKF	RSTF	SUSPND F	EOPF	RESUM F	00	
E9	UIF1	–	–	–	IN4F	IN3F	IN2F	IN1F	IN0F	00	
EA	UIF2	–	–	–	OUT4F	OUT3F	OUT2F	OUT1F	OUT0F	00	
EB	UIF3	–	–	–	NAK4F	NAK3F	NAK2F	NAK1F	NAK0F	00	
EC	UCTL	–	–	–	–	–	USBEN	VISIBL E	WAKEU P	00	
ED	USTA	–	–	–	–	RCVT	SETUP	IN	OUT	00	
EE	RESERVED										
EF	USEL	DIR	–	–	–	–	EP[2:0]			00	
F0 ⁽¹⁾	B	B[7:0] <bit addresses: F7h, F6h, F5h, F4h, F3h, F2h, F1h, F0h>								00	Section 7.5
F1	UCON	–	–	–	–	ENABLE	STALL	TOGGL E	BSY	08	
F2	USIZE	–	SIZE[6:0]							00	
F3	UBASEH	BASEADDR[15:8]								00	
F4	UBASEL	BASEADDR[7:6]		0	0	0	0	0	0	00	
F5	USCI	–	–	–	–	–	USCI[2:0]			00	
F6	USCV	USCV[7:0]								00	
F7	RESERVED										
F8	RESERVED										

Table 5. SFR memory map with direct address and reset value (continued)

SFR addr (hex)	SFR name	Bit name and <bit address>								Reset value (hex)	Reg. descr. with link
		7	6	5	4	3	2	1	0		
F9	CCON0	PLLM[4]	PLLEN	UPLLCE	DBGCE	CPU_ AR	CPUPS[2:0]			50	Table 27
FA	CCON1	PLLM[3:0]				PLLD[3:0]				00	
FB	CCON2	–	–	–	PCA0CE	PCA0PS[3:0]				10	Table 144
FC	CCON3	–	–	–	PCA1CE	PCA1PS[3:0]				10	Table 146
FD	RESERVED										
FE	RESERVED										
FF	RESERVED										
FE	RESERVED										
FF	RESERVED										

1. This SFR can be addressed by individual bits (bit address mode) or addressed by the entire byte (direct address mode).

9 8032 addressing modes

The 8032 MCU uses 11 different addressing modes listed below:

- Register
- Direct
- Register indirect
- Immediate
- External direct
- External indirect
- Indexed
- Relative
- Absolute
- Long
- Bit

9.1 Register addressing

This mode uses the contents of one of the registers R0 - R7 (selected by the last three bits in the instruction opcode) as the operand source or destination. This mode is very efficient since an additional instruction byte is not needed to identify the operand. For example:

```
MOV A, R7 ; Move contents of R7 to accumulator
```

9.2 Direct addressing

This mode uses an 8-bit address, which is contained in the second byte of the instruction, to directly address an operand which resides in either 8032 DATA SRAM (internal address range 00h-07Fh) or resides in 8032 SFR (internal address range 80h-FFh). This mode is quite fast since the range limit is 256 bytes of internal 8032 SRAM. For example:

```
MOV A, 40h ; Move contents of DATA SRAM
           ; at location 40h into the accumulator
```

9.3 Register indirect addressing

This mode uses an 8-bit address contained in either register R0 or R1 to indirectly address an operand which resides in 8032 IDATA SRAM (internal address range 80h-FFh). Although 8032 SFR registers also occupy the same physical address range as IDATA, SFRs will not be accessed by register Indirect mode. SFRs may only be accessed using Direct address mode. For example:

```
MOV A, @R0 ; Move into the accumulator the
           ; contents of IDATA SRAM that is
           ; pointed to by the address
           ; contained in R0.
```

9.4 Immediate addressing

This mode uses 8-bits of data (a constant) contained in the second byte of the instruction, and stores it into the memory location or register indicated by the first byte of the instruction. Thus, the data is immediately available within the instruction. This mode is commonly used to initialize registers and SFRs or to perform mask operations.

There is also a 16-bit version of this mode for loading the DPTR register. In this case, the two bytes following the instruction byte contain the 16-bit value. For example:

```
MOV A, 40#                ; Move the constant, 40h, into
                          ; the accumulator
MOV DPTR, 1234#          ; Move the constant, 1234h, into
                          ; DPTR
```

9.5 External direct addressing

This mode will access external memory (XDATA) by using the 16-bit address stored in the DPTR register. There are only two instructions using this mode and both use the accumulator to either receive a byte from external memory addressed by DPTR or to send a byte from the accumulator to the address in DPTR. The UPSD34xx has a special feature to alternate the contents (source and destination) of DPTR rapidly to implement very efficient memory-to-memory transfers. For example:

```
MOVX A, @DPTR            ; Move contents of accumulator to
                          ; XDATA at address contained in
                          ; DPTR
MOVX @DPTR, A            ; Move XDATA to accumulator
```

Note: See details in [Section 11: Dual data pointers on page 57](#).

9.6 External indirect addressing

This mode will access external memory (XDATA) by using the 8-bit address stored in either register R0 or R1. This is the fastest way to access XDATA (least bus cycles), but because only 8-bits are available for address, this mode limits XDATA to a size of only 256 bytes (the traditional Port 2 of the 8032 MCU is not available in the UPSD34xx, so it is not possible to write the upper address byte).

For example:

```
MOVX @R0,A              ; Move into the accumulator the
                          ; XDATA that is pointed to by
                          ; the address contained in R0.
```

Note: This mode is not supported by UPSD34xx.

9.7 Indexed addressing

This mode is used for the MOVC instruction which allows the 8032 to read a constant from program memory (not data memory). MOVC is often used to read look-up tables that are embedded in program memory. The final address produced by this mode is the result of adding either the 16-bit PC or DPTR value to the contents of the accumulator. The value in the accumulator is referred to as an index. The data fetched from the final location in program memory is stored into the accumulator, overwriting the index value that was previously stored there. For example:

```
MOVC A, @A+DPTR      ; Move code byte relative to
                      ; DPTR into accumulator

MOVC A, @A+PC        ; Move code byte relative to PC
                      ; into accumulator
```

9.8 Relative addressing

This mode will add the two's-compliment number stored in the second byte of the instruction to the program counter for short jumps within +128 or -127 addresses relative to the program counter. This is commonly used for looping and is very efficient since no additional bus cycle is needed to fetch the jump destination address. For example:

```
SJMP 34h              ; Jump 34h bytes ahead (in program
                      ; memory) of the address at which
                      ; the SJMP instruction is stored. If
                      ; SJMP is at 1000h, program
                      ; execution jumps to 1034h.
```

9.9 Absolute addressing

This mode will append the 5 high-order bits of the address of the next instruction to the 11 low-order bits of an ACALL or AJUMP instruction to produce a 16-bit jump address. The jump will be within the same 2 Kbyte page of program memory as the first byte of the following instruction. For example:

```
AJMP 0500h           ; If next instruction is located at
                      ; address 4000h, the resulting jump
                      ; will be made to 4500h.
```

9.10 Long addressing

This mode will use the 16-bits contained in the two bytes following the instruction byte as a jump destination address for LCALL and LJMP instructions. For example:

```
LJMP 0500h           ; Unconditionally jump to address
                      ; 0500h in program memory
```

9.11 Bit addressing

This mode allows setting or clearing an individual bit without disturbing the other bits within an 8-bit value of internal SRAM. Bit Addressing is only available for certain locations in 8032 DATA and SFR memory. Valid locations are DATA addresses 20h - 2Fh and for SFR addresses whose base address ends with 0h or 8h. (Example: The SFR, IE, has a base address of A8h, so each of the eight bits in IE can be addressed individually at address A8h, A9h, ...up to AFh.) For example:

```
SETB AFh          ; Set the individual EA bit (Enable All ; Interrupts) inside the SFR register,  
                  ; IE.
```

Obsolete Product(s) - Obsolete Product(s)
Obsolete Product(s) - Obsolete Product(s)

10 UPSD34xx instruction set summary

Tables 6 through 11 list all of the instructions supported by the UPSD34xx, including the number of bytes and number of machine cycles required to implement each instruction. This is the standard 8051 instruction set.

The meaning of “machine cycles” is how many 8032 MCU core machine cycles are required to execute the instruction. The “native” duration of all machine cycles is set by the memory wait state settings in the SFR, BUSCON, and the MCU clock divider selections in the SFR, CCON0 (i.e. a machine cycle is typically set to 4 MCU clocks for a 5 V UPSD34xx).

However, an individual machine cycle may grow in duration when either of two things happen:

1. a stall is imposed while loading the 8032 Pre-Fetch Queue (PFQ); or
2. the occurrence of a cache miss in the Branch Cache (BC) during a branch in program execution flow.

See [Section 5: 8032 MCU core performance enhancements on page 33](#) or more details.

But generally speaking, during typical program execution, the PFQ is not empty and the BC has no misses, producing very good performance without extending the duration of any machine cycles.

Table 6. Arithmetic instruction set

Mnemonic ⁽¹⁾ and use		Description	Length/cycles
ADD	A, Rn	Add register to ACC	1 byte/1 cycle
ADD	A, Direct	Add direct byte to ACC	2 byte/1 cycle
ADD	A, @Ri	Add indirect SRAM to ACC	1 byte/1 cycle
ADD	A, #data	Add immediate data to ACC	2 byte/1 cycle
ADDC	A, Rn	Add register to ACC with carry	1 byte/1 cycle
ADDC	A, direct	Add direct byte to ACC with carry	2 byte/1 cycle
ADDC	A, @Ri	Add indirect SRAM to ACC with carry	1 byte/1 cycle
ADDC	A, #data	Add immediate data to ACC with carry	2 byte/1 cycle
SUBB	A, Rn	Subtract register from ACC with borrow	1 byte/1 cycle
SUBB	A, direct	Subtract direct byte from ACC with borrow	2 byte/1 cycle
SUBB	A, @Ri	Subtract indirect SRAM from ACC with borrow	1 byte/1 cycle
SUBB	A, #data	Subtract immediate data from ACC with borrow	2 byte/1 cycle
INC	A	Increment A	1 byte/1 cycle
INC	Rn	Increment register	1 byte/1 cycle
INC	direct	Increment direct byte	2 byte/1 cycle
INC	@Ri	Increment indirect SRAM	1 byte/1 cycle
DEC	A	Decrement ACC	1 byte/1 cycle
DEC	Rn	Decrement register	1 byte/1 cycle
DEC	direct	Decrement direct byte	2 byte/1 cycle

Table 6. Arithmetic instruction set (continued)

Mnemonic ⁽¹⁾ and use		Description	Length/cycles
DEC	@Ri	Decrement indirect SRAM	1 byte/1 cycle
INC	DPTR	Increment Data Pointer	1 byte/2 cycle
MUL	AB	Multiply ACC and B	1 byte/4 cycle
DIV	AB	Divide ACC by B	1 byte/4 cycle
DA	A	Decimal adjust ACC	1 byte/1 cycle

1. All mnemonics copyrighted ©Intel Corporation 1980.

Table 7. Logical instruction set

Mnemonic ⁽¹⁾ and use		Description	Length/cycles
Logical Instructions			
ANL	A, Rn	AND register to ACC	1 byte/1 cycle
ANL	A, direct	AND direct byte to ACC	2 byte/1 cycle
ANL	A, @Ri	AND indirect SRAM to ACC	1 byte/1 cycle
ANL	A, #data	AND immediate data to ACC	2 byte/1 cycle
ANL	direct, A	AND ACC to direct byte	2 byte/1 cycle
ANL	direct, #data	AND immediate data to direct byte	3 byte/2 cycle
ORL	A, Rn	OR register to ACC	1 byte/1 cycle
ORL	A, direct	OR direct byte to ACC	2 byte/1 cycle
ORL	A, @Ri	OR indirect SRAM to ACC	1 byte/1 cycle
ORL	A, #data	OR immediate data to ACC	2 byte/1 cycle
ORL	direct, A	OR ACC to direct byte	2 byte/1 cycle
ORL	direct, #data	OR immediate data to direct byte	3 byte/2 cycle
SWAP	A	Swap nibbles within the ACC	1 byte/1 cycle
XRL	A, Rn	Exclusive-OR register to ACC	1 byte/1 cycle
XRL	A, direct	Exclusive-OR direct byte to ACC	2 byte/1 cycle
XRL	A, @Ri	Exclusive-OR indirect SRAM to ACC	1 byte/1 cycle
XRL	A, #data	Exclusive-OR immediate data to ACC	2 byte/1 cycle
XRL	direct, A	Exclusive-OR ACC to direct byte	2 byte/1 cycle
XRL	direct, #data	Exclusive-OR immediate data to direct byte	3 byte/2 cycle
CLR	A	Clear ACC	1 byte/1 cycle
CPL	A	Compliment ACC	1 byte/1 cycle
RL	A	Rotate ACC left	1 byte/1 cycle
RLC	A	Rotate ACC left through the carry	1 byte/1 cycle
RR	A	Rotate ACC right	1 byte/1 cycle
RRC	A	Rotate ACC right through the carry	1 byte/1 cycle

1. All mnemonics copyrighted ©Intel Corporation 1980.

Table 8. Data transfer instruction set

Mnemonic ⁽¹⁾ and use		Description	Length/cycles
MOV	A, Rn	Move register to ACC	1 byte/1 cycle
MOV	A, direct	Move direct byte to ACC	2 byte/1 cycle
MOV	A, @Ri	Move indirect SRAM to ACC	1 byte/1 cycle
MOV	A, #data	Move immediate data to ACC	2 byte/1 cycle
MOV	Rn, A	Move ACC to register	1 byte/1 cycle
MOV	Rn, direct	Move direct byte to register	2 byte/2 cycle
MOV	Rn, #data	Move immediate data to register	2 byte/1 cycle
MOV	direct, A	Move ACC to direct byte	2 byte/1 cycle
MOV	direct, Rn	Move register to direct byte	2 byte/2 cycle
MOV	direct, direct	Move direct byte to direct	3 byte/2 cycle
MOV	direct, @Ri	Move indirect SRAM to direct byte	2 byte/2 cycle
MOV	direct, #data	Move immediate data to direct byte	3 byte/2 cycle
MOV	@Ri, A	Move ACC to indirect SRAM	1 byte/1 cycle
MOV	@Ri, direct	Move direct byte to indirect SRAM	2 byte/2 cycle
MOV	@Ri, #data	Move immediate data to indirect SRAM	2 byte/1 cycle
MOV	DPTR, #data16	Load Data Pointer with 16-bit constant	3 byte/2 cycle
MOVC	A, @A+DPTR	Move code byte relative to DPTR to ACC	1 byte/2 cycle
MOVC	A, @A+PC	Move code byte relative to PC to ACC	1 byte/2 cycle
MOVX	A, @Ri ⁽²⁾	Move XDATA (8-bit addr) to ACC	1 byte/2 cycle
MOVX	A, @DPTR	Move XDATA (16-bit addr) to ACC	1 byte/2 cycle
MOVX	@Ri, A ⁽²⁾	Move ACC to XDATA (8-bit addr)	1 byte/2 cycle
MOVX	@DPTR, A	Move ACC to XDATA (16-bit addr)	1 byte/2 cycle
XCH	A, Rn	Exchange register with ACC	1 byte/1 cycle
PUSH	direct	Push direct byte onto stack	2 byte/2 cycle
POP	direct	Pop direct byte from stack	2 byte/2 cycle
XCH	A, direct	Exchange direct byte with ACC	2 byte/1 cycle
XCH	A, @Ri	Exchange indirect SRAM with ACC	1 byte/1 cycle
XCHD	A, @Ri	Exchange low-order digit indirect SRAM with ACC	1 byte/1 cycle

1. All mnemonics copyrighted ©Intel Corporation 1980.

2. This instruction is not supported by UPSD34xx. See [Section 9.6: External indirect addressing on page 49](#)

Table 9. Boolean variable manipulation instruction set

Mnemonic ⁽¹⁾ and use		Description	Length/cycles
CLR	C	Clear carry	1 byte/1 cycle
CLR	bit	Clear direct bit	2 byte/1 cycle
SETB	C	Set carry	1 byte/1 cycle
SETB	bit	Set direct bit	2 byte/1 cycle
CPL	C	Compliment carry	1 byte/1 cycle
CPL	bit	Compliment direct bit	2 byte/1 cycle
ANL	C, bit	AND direct bit to carry	2 byte/2 cycle
ANL	C, /bit	AND compliment of direct bit to carry	2 byte/2 cycle
ORL	C, bit	OR direct bit to carry	2 byte/2 cycle
ORL	C, /bit	OR compliment of direct bit to carry	2 byte/2 cycle
MOV	C, bit	Move direct bit to carry	2 byte/1 cycle
MOV	bit, C	Move carry to direct bit	2 byte/2 cycle
JC	rel	Jump if carry is set	2 byte/2 cycle
JNC	rel	Jump if carry is not set	2 byte/2 cycle
JB	rel	Jump if direct bit is set	3 byte/2 cycle
JNB	rel	Jump if direct bit is not set	3 byte/2 cycle
JBC	bit, rel	Jump if direct bit is set and clear bit	3 byte/2 cycle

1. All mnemonics copyrighted ©Intel Corporation 1980.

Table 10. Program branching instruction set

Mnemonic ⁽¹⁾ and use		Description	Length/cycles
Program Branching Instructions			
ACALL	addr11	Absolute subroutine call	2 byte/2 cycle
LCALL	addr16	Long subroutine call	3 byte/2 cycle
RET		Return from subroutine	1 byte/2 cycle
RETI		Return from interrupt	1 byte/2 cycle
AJMP	addr11	Absolute jump	2 byte/2 cycle
LJMP	addr16	Long jump	3 byte/2 cycle
SJMP	rel	Short jump (relative addr)	2 byte/2 cycle
JMP	@A+DPTR	Jump indirect relative to the DPTR	1 byte/2 cycle
JZ	rel	Jump if ACC is zero	2 byte/2 cycle
JNZ	rel	Jump if ACC is not zero	2 byte/2 cycle
CJNE	A, direct, rel	Compare direct byte to ACC, jump if not equal	3 byte/2 cycle
CJNE	A, #data, rel	Compare immediate to ACC, jump if not equal	3 byte/2 cycle
CJNE	Rn, #data, rel	Compare immediate to register, jump if not equal	3 byte/2 cycle

Table 10. Program branching instruction set (continued)

Mnemonic ⁽¹⁾ and use		Description	Length/cycles
CJNE	@Ri, #data, rel	Compare immediate to indirect, jump if not equal	3 byte/2 cycle
DJNZ	Rn, rel	Decrement register and jump if not zero	2 byte/2 cycle
DJNZ	direct, rel	Decrement direct byte and jump if not zero	3 byte/2 cycle

1. All mnemonics copyrighted ©Intel Corporation 1980.

Table 11. Miscellaneous instruction set

Mnemonic ⁽¹⁾ and Use		Description	Length/Cycles
Miscellaneous			
NOP		No operation	1 byte/1 cycle

1. All mnemonics copyrighted ©Intel Corporation 1980.

Table 12. Notes on instruction set and addressing modes

Rn	Register R0 - R7 of the currently selected register bank.
direct	8-bit address for internal 8032 DATA SRAM (locations 00h - 7Fh) or SFR registers (locations 80h - FFh).
@Ri	8-bit internal 8032 SRAM (locations 00h - FFh) addressed indirectly through contents of R0 or R1.
#data	8-bit constant included within the instruction.
#data16	16-bit constant included within the instruction.
addr16	16-bit destination address used by LCALL and LJMP.
addr11	11-bit destination address used by ACALL and AJMP.
rel	Signed (two's complement) 8-bit offset byte.
bit	Direct addressed bit in internal 8032 DATA SRAM (locations 20h to 2Fh) or in SFR registers (88h, 90h, 98h, A8h, B0, B8h, C0h, C8h, D0h, D8h, E0h, F0h).

11 Dual data pointers

XDATA is accessed by the External Direct addressing mode, which uses a 16-bit address stored in the DPTR register. Traditional 8032 architecture has only one DPTR register. This is a burden when transferring data between two XDATA locations because it requires heavy use of the working registers to manipulate the source and destination pointers.

However, the UPSD34xx has two data pointers, one for storing a source address and the other for storing a destination address. These pointers can be configured to automatically increment or decrement after each data transfer, further reducing the burden on the 8032 and making this kind of data movement very efficient.

11.1 Data pointer control register, DPTC (85h)

By default, the DPTR register of the UPSD34xx will behave no different than in a standard 8032 MCU. The DPSEL0 Bit of SFR register DPTC shown in [Table 13](#), selects which one of the two “background” data pointer registers (DPTR0 or DPTR1) will function as the traditional DPTR register at any given time. After reset, the DPSEL0 Bit is cleared, enabling DPTR0 to function as the DPTR, and firmware may access DPTR0 by reading or writing the traditional DPTR register at SFR addresses 82h and 83h. When the DPSEL0 bit is set, then the DPTR1 register functions as DPTR, and firmware may now access DPTR1 through SFR registers at 82h and 83h. The pointer which is not selected by the DPSEL0 bit remains in the background and is not accessible by the 8032. If the DPSEL0 bit is never set, then the UPSD34xx will behave like a traditional 8032 having only one DPTR register.

To further speed XDATA to XDATA transfers, the SFR bit, AT, may be set to automatically toggle the two data pointers, DPTR0 and DPTR1, each time the standard DPTR register is accessed by a MOVX instruction. This eliminates the need for firmware to manually manipulate the DPSEL0 bit between each data transfer.

Detailed description for the SFR register DPTC is shown in [Table 13](#).

Table 13. DPTC: data pointer control register (SFR 85h, reset value 00h)

Bit 7	Bit 6	Bit 5	Bit 4	Bit 3	Bit 2	Bit 1	Bit 0
–	AT	–	–	–	–	–	DPSEL0

Table 14. DPTC register bit definition

Bit	Symbol	R/W	Definition
7	–	–	Reserved
6	AT	R,W	0 = Manually select data pointer 1 = Auto toggle between DPTR0 and DPTR1
5-1	–	–	Reserved
0	DPSEL0	R,W	0 = DPTR0 selected for use as DPTR 1 = DPTR1 selected for use as DPTR

11.2 Data pointer mode register, DPTM (86h)

The two “background” data pointers, DPTR0 and DPTR1, can be configured to automatically increment, decrement, or stay the same after a MOVX instruction accesses the DPTR register. Only the currently selected pointer will be affected by the increment or decrement. This feature is controlled by the DPTM register defined in [Table 15](#).

The automatic increment or decrement function is effective only for the MOVX instruction, and not MOVC or any other instruction that uses the DTPR register.

11.2.1 Firmware example

The 8051 assembly code illustrated in [Table](#) shows how to transfer a block of data bytes from one XDATA address region to another XDATA address region. Auto-address incrementing and auto-pointer toggling will be used.

Table 15. DPTM: data pointer mode register (SFR 86h, reset value 00h)

Bit 7	Bit 6	Bit 5	Bit 4	Bit 3	Bit 2	Bit 1	Bit 0
–	–	–	–	MD11	MD10	MD01	MD00

Table 16. DPTM register bit definition

Bit	Symbol	R/W	Definition
7-4	–	–	Reserved
3-2	MD[11:10]	R,W	DPTR1 mode bits 00: DPTR1 No change 01: Reserved 10: Auto Increment 11: Auto Decrement
1-0	MD[01:00]	R,W	DPTR0 mode bits 00: DPTR0 No change 01: Reserved 10: Auto Increment 11: Auto Decrement

8051 assembly code example

```

MOV      R7, #COUNT      ; initialize size of data block to transfer
MOV      DPTR,            ; load XDATA source address base into DPTR0
        #SOURCE_ADDR
MOV      85h, #01h        ; load DPTC to access DPTR1 pointer
MOV      DPTR, #DEST_ADDR ; load XDATA destination address base into DPTR1
MOV      85h, #40h        ; load DPTC to access DPTR0 pointer and auto
                           ; toggle
MOV      86h, #0Ah        ; load DPTM to auto-increment both pointers
LOOP:    MOVX(1) A, @DPTR    ; load XDATA byte from source into ACC.
                           ; after load completes, DPTR0 increments and
                           ; DPTR
                           ; switches DPTR1
MOVX(1) @DPTR, A          ; store XDATA byte from ACC to destination.
                           ; after store completes, DPTR1 increments and
                           ; DPTR
                           ; switches to DPTR0
DJNZ(1) R7, LOOP          ; continue until done
MOV      86h, #00        ; disable auto-increment
MOV      85h, #00        ; disable auto-toggle, now back to single DPTR
                           ; mode

```

Note: 1 The code loop where the data transfer takes place is only 3 lines of code.

12 Debug unit

The 8032 MCU module supports run-time debugging through the JTAG interface. This same JTAG interface is also used for In-System Programming (ISP) and the physical connections are described in the PSD module section, [Section 28.6.1: JTAG ISP and JTAG debug on page 257](#).

Debugging with a serial interface such as JTAG is a non-intrusive way to gain access to the internal state of the 8032 MCU core and various memories. A traditional external hardware emulator cannot be completely effective on the UPSD34xx because of the Pre-Fetch Queue and Branch Cache. The nature of the PFQ and BC hide the visibility of actual program flow through traditional external bus connections, thus requiring on-chip serial debugging instead.

Debugging is supported by Windows PC based software tools used for 8051 code development from 3rd party vendors listed at www.st.com/psm. Debug capabilities include:

- Halt or start MCU execution
- Reset the MCU
- Single step
- 3 match breakpoints
- 1 range breakpoint (inside or outside range)
- Program tracing
- Read or modify MCU core registers, DATA, IDATA, SFR, XDATA, and code
- External debug event pin, input or output

Some key points regarding use of the JTAG debugger.

- The JTAG debugger can access MCU registers, data memory, and code memory while the MCU is executing at full speed by cycle-stealing. This means “watch windows” may be displayed and periodically updated on the PC during full speed operation. Registers and data content may also be modified during full speed operation.
- There is no on-chip storage for Program Trace data, but instead this data is scanned from the UPSD34xx through the JTAG channel at run-time to the PC host for processing. As such, full speed program tracing is possible only when the 8032 MCU is operating below approximately one MIPS of performance. Above one MIPS, the program will not run real-time while tracing. One MIPS performance is determined by the combination of choice for MCU clock frequency, and the bit settings in SFR registers BUSCON and CCON0.
- Breakpoints can optionally halt the MCU, and/or assert the external Debug Event pin.
- Breakpoint definitions may be qualified with read or write operations, and may also be qualified with an address of code, SFR, DATA, IDATA, or XDATA memories.
- Three breakpoints will compare an address, but the fourth breakpoint can compare an address and also data content. Additionally, the fourth breakpoint can be logically combined (AND/OR) with any of the other three breakpoints.
- The Debug Event pin can be configured by the PC host to generate an output pulse for external triggering when a break condition is met. The pin can also be configured as an event input to the breakpoint logic, causing a break on the falling-edge of an external event signal. If not used, the Debug Event pin should be pulled

up to V_{CC} as described in the section, [Section 28.6.8: Debugging the 8032 MCU module on page 263](#).

- The duration of a pulse, generated when the Event pin configured as an output, is one MCU clock cycle. This is an active-low signal, so the first edge when an event occurs is high-to-low.
- The clock to the Watchdog Timer, ADC, and I²C interface are not stopped by a breakpoint halt.
- The Watchdog Timer should be disabled while debugging with JTAG, else a reset will be generated upon a watchdog time-out.

Obsolete Product(s) - Obsolete Product(s)
Obsolete Product(s) - Obsolete Product(s)

13 Interrupt system

The UPSD34xx has an 12-source, two priority level interrupt structure summarized in [Table 17](#).

Firmware may assign each interrupt source either high or low priority by writing to bits in the SFRs named, IP and IPA, shown in [Table 17](#). An interrupt will be serviced as long as an interrupt of equal or higher priority is not already being serviced. If an interrupt of equal or higher priority is being serviced, the new interrupt will wait until it is finished before being serviced. If a lower priority interrupt is being serviced, it will be stopped and the new interrupt is serviced. When the new interrupt is finished, the lower priority interrupt that was stopped will be completed. If new interrupt requests are of the same priority level and are received simultaneously, an internal polling sequence determines which request is selected for service. Thus, within each of the two priority levels, there is a second priority structure determined by the polling sequence.

Firmware may individually enable or disable interrupt sources by writing to bits in the SFRs named, IE and IEA, shown in [Table 17 on page 63](#). The SFR named IE contains a global disable bit (EA), which can be cleared to disable all 12 interrupts at once, as shown in [Table 18 on page 66](#). [Figure 12 on page 64](#) illustrates the interrupt priority, polling, and enabling process.

Each interrupt source has at least one interrupt flag that indicates whether or not an interrupt is pending. These flags reside in bits of various SFRs shown in [Table 17 on page 63](#).

All of the interrupt flags are latched into the interrupt control system at the beginning of each MCU machine cycle, and they are polled at the beginning of the following machine cycle. If polling determines one of the flags was set, the interrupt control system automatically generates an LCALL to the user's Interrupt Service Routine (ISR) firmware stored in program memory at the appropriate vector address.

- The specific vector address for each of the interrupt sources are listed in [Table 17 on page 63](#). However, this LCALL jump may be blocked by any of the following conditions:
- An interrupt of equal or higher priority is already in progress
- The current machine cycle is not the final cycle in the execution of the instruction in progress
- The current instruction involves a write to any of the SFRs: IE, IEA, IP, or IPA
- The current instruction is an RETI

Note: Interrupt flags are polled based on a sample taken in the previous MCU machine cycle. If an interrupt flag is active in one cycle but is denied serviced due to the conditions above, and then later it is not active when the conditions above are finally satisfied, the previously denied interrupt will not be serviced. This means that active interrupts are not remembered. Every polling cycle is new.

Assuming all of the listed conditions are satisfied, the MCU executes the hardware generated LCALL to the appropriate ISR. This LCALL pushes the contents of the PC onto the stack (but it does not save the PSW) and loads the PC with the appropriate interrupt vector address. Program execution then jumps to the ISR at the vector address.

Execution precedes in the ISR. It may be necessary for the ISR firmware to clear the pending interrupt flag for some interrupt sources, because not all interrupt flags are automatically cleared by hardware when the ISR is called, as shown in [Table 17 on page 63](#).

If an interrupt flag is not cleared after servicing the interrupt, an unwanted interrupt will occur upon exiting the ISR.

After the interrupt is serviced, the last instruction executed by the ISR is RETI. The RETI informs the MCU that the ISR is no longer in progress and the MCU pops the top two bytes from the stack and loads them into the PC. Execution of the interrupted program continues where it left off.

Note: An ISR must end with a RETI instruction, not a RET. An RET will not inform the interrupt control system that the ISR is complete, leaving the MCU to think the ISR is still in progress, making future interrupts impossible.

Table 17. Interrupt summary

Interrupt source	Polling priority	Vector addr	Flag bit name (SFR.bit position) 1 = Intr pending 0 = No interrupt	Flag bit auto-cleared by hardware?	Enable bit name (SFR.bit position) 1 = Intr Enabled 0 = Intr Disabled	Priority bit name (SFR.bit position) 1 = High Priority 0 = Low Priority
Reserved	0 (high)	0063h	–	–	–	–
External Interrupt INT0	1	0003h	IE0 (TCON.1)	Edge - Yes Level - No	EX0 (IE.0)	PX0 (IP.0)
Timer 0 Overflow	2	000Bh	TF0 (TCON.5)	Yes	ET0 (IE.1)	PT0 (IP.1)
External Interrupt INT1	3	0013h	IE1 (TCON.3)	Edge - Yes Level - No	EX1 (IE.2)	PX1 (IP.2)
Timer 1 Overflow	4	001Bh	TF1 (TCON.7)	Yes	ET1 (IE.3)	PT1 (IP.3)
UART0	5	0023h	RI (SCON0.0) TI (SCON0.1)	No	ES0 (IE.4)	PS0 (IP.4)
Timer 2 Overflow or TX2 Pin	6	002Bh	TF2 (T2CON.7) EXF2 (T2CON.6)	No	ET2 (IE.5)	PT2 (IP.5)
SPI	7	0053h	TEISF, RORISF, TISF, RISF (SPISTAT[3:0])	Yes	ESPI (IEA.6)	PSPI (IPA.6)
USB	8	0033h	– ⁽¹⁾	No	EUSB (IEA.0)	PUSB (IPA.0)
I ² C	9	0043h	INTR (S1STA.5)	Yes	EI ² C (IEA.1)	PI ² C (IPA.1)
ADC	10	003Bh	AINTF (ACON.7)	No	EADC (IEA.7)	PADC (IPA.7)
PCA	11	005Bh	OFVx, INTFx (PCASTA[0:7])	No	EPCA (IEA.5)	PPCA (IPA.5)
UART1	12 (low)	004Bh	RI (SCON1.0) TI (SCON1.1)	No	ES1 (IEA.4)	PS1 (IPA.4)

1. See USB interrupt flag registers UIF0-3.

Figure 12. Enabling and polling interrupts

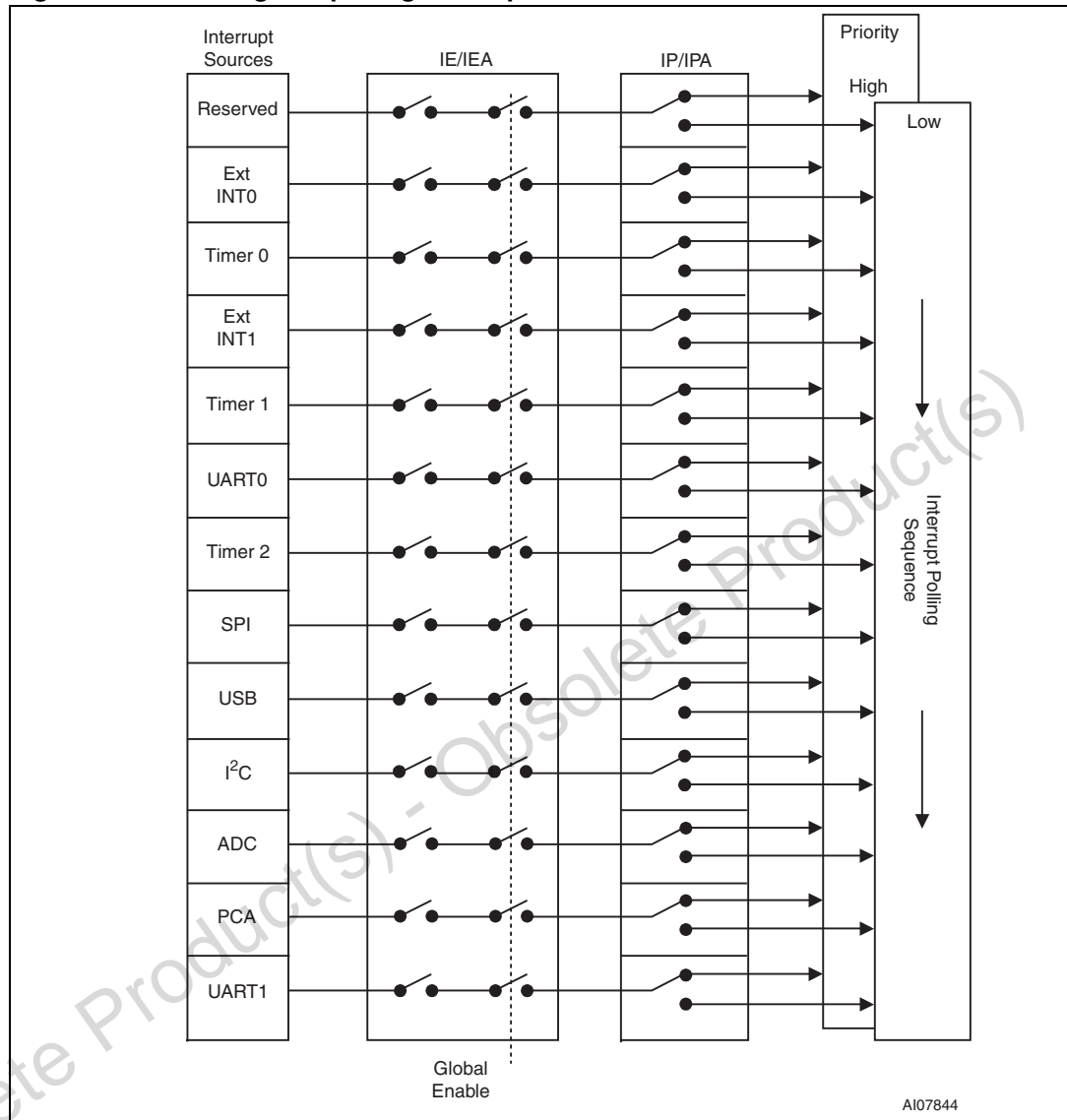

13.1 Individual interrupt sources

13.1.1 External interrupts Int0 and Int1

External interrupt inputs on pins EXTINT0 and EXTINT1 (pins 3.2 and 3.3) are either edge-triggered or level-triggered, depending on bits IT0 and IT1 in the SFR named TCON.

When an external interrupt is generated from an edge-triggered (falling-edge) source, the appropriate flag bit (IE0 or IE1) is automatically cleared by hardware upon entering the ISR.

When an external interrupt is generated from a level-triggered (low-level) source, the appropriate flag bit (IE0 or IE1) is NOT automatically cleared by hardware.

13.1.2 Timer 0 and 1 overflow interrupt

Timer 0 and Timer 1 interrupts are generated by the flag bits TF0 and TF1 when there is an overflow condition in the respective Timer/Counter register (except for Timer 0 in Mode 3).

13.1.3 Timer 2 overflow interrupt

This interrupt is generated to the MCU by a logical OR of flag bits, TF2 and EXE2. The ISR must read the flag bits to determine the cause of the interrupt.

- TF2 is set by an overflow of Timer 2.
- EXE2 is generated by the falling edge of a signal on the external pin, T2X (pin P1.1).

13.1.4 UART0 and UART1 interrupt

Each of the UARTs have identical interrupt structure. For each UART, a single interrupt is generated to the MCU by the logical OR of the flag bits, RI (byte received) and TI (byte transmitted).

The ISR must read flag bits in the SFR named SCON0 for UART0, or SCON1 for UART1 to determine the cause of the interrupt.

13.1.5 SPI interrupt

The SPI interrupt has four interrupt sources, which are logically ORed together when interrupting the MCU. The ISR must read the flag bits to determine the cause of the interrupt.

A flag bit is set for: end of data transmit (TEISF); data receive overrun (RORISF); transmit buffer empty (TISF); or receive buffer full (RISF).

13.1.6 I²C interrupt

The flag bit INTR is set by a variety of conditions occurring on the I²C interface: received own slave address (ADDR flag); received general call address (GC flag); received Stop condition (STOP flag); or successful transmission or reception of a data byte. The ISR must read the flag bits to determine the cause of the interrupt.

13.1.7 ADC interrupt

The flag bit AINTF is set when an A-to-D conversion has completed.

13.1.8 PCA interrupt

The PCA has eight interrupt sources, which are logically ORed together when interrupting the MCU. The ISR must read the flag bits to determine the cause of the interrupt.

- Each of the six TCMs can generate a "match or capture" interrupt on flag bits OFV5..0 respectively.
- Each of the two 16-bit counters can generate an overflow interrupt on flag bits INTF1 and INTF0 respectively.

Tables 18 through Table 24 on page 67 have detailed bit definitions of the interrupt system SFRs.

13.1.9 USB interrupt

The USB interrupt has multiple sources. The ISR must read the USB interrupt flag registers (UIF0-3) to determine the source of the interrupt.

The USB interrupt can be activated by any of the following four group of interrupt sources:

- Global: the interrupt flag is set when any of the following events occurs: USB Reset, USB Suspend, USB Resume, and End of Packet;
- In FIFO: the interrupt flag is set when any of the End Point In FIFO becomes empty;
- Out FIFO: the interrupt flag is set when any of the End Point Out FIFO becomes full; and
- In FIFO NAK: the interrupt flag is set when any of the End Point In FIFO is not ready for an IN (in-bound) packet.

Table 18. IE: interrupt enable register (SFR A8h, reset value 00h)

Bit 7	Bit 6	Bit 5	Bit 4	Bit 3	Bit 2	Bit 1	Bit 0
EA	–	ET2	ES0	ET1	EX1	ET0	EX0

Table 19. IE register bit definition

Bit	Symbol	R/W	Function
7	EA	R,W	Global disable bit. 0 = All interrupts are disabled. 1 = Each interrupt source can be individually enabled or disabled by setting or clearing its enable bit.
6	–	R,W	Do not modify this bit. It is used by the JTAG debugger for instruction tracing. Always read the bit and write back the same bit value when writing this SFR.
5 ⁽¹⁾	ET2	R,W	Enable Timer 2 Interrupt
4 ⁽¹⁾	ES0	R,W	Enable UART0 Interrupt
3 ⁽¹⁾	ET1	R,W	Enable Timer 1 Interrupt
2 ⁽¹⁾	EX1	R,W	Enable External Interrupt INT1
1 ⁽¹⁾	ET0	R,W	Enable Timer 0 Interrupt
0 ⁽¹⁾	EX0	R,W	Enable External Interrupt INT0

1. 1 = Enable Interrupt, 0 = Disable Interrupt.

Table 20. IEA: interrupt enable addition register (SFR A7h, reset value 00h)

Bit 7	Bit 6	Bit 5	Bit 4	Bit 3	Bit 2	Bit 1	Bit 0
EADC	ESPI	EPCA	ES1	–	–	EI ² C	EUSB

Table 21. IEA register bit definition

Bit	Symbol	R/W	Function
7 ⁽¹⁾	EADC	R,W	Enable ADC Interrupt
6 ⁽¹⁾	ESPI	R,W	Enable SPI Interrupt
5 ⁽¹⁾	EPCA	R,W	Enable Programmable Counter Array Interrupt
4 ⁽¹⁾	ES1	R,W	Enable UART1 Interrupt

Table 21. IEA register bit definition (continued)

Bit	Symbol	R/W	Function
3	–	–	Reserved, do not set to logic '1.'
2	–	–	Reserved, do not set to logic '1.'
1 ⁽¹⁾	E ² C	R,W	Enable I ² C Interrupt
0	EUSB	R,W	Enable USB Interrupt

1. 1 = Enable Interrupt, 0 = Disable Interrupt.

Table 22. IP: interrupt priority register (SFR B8h, reset value 00h)

Bit 7	Bit 6	Bit 5	Bit 4	Bit 3	Bit 2	Bit 1	Bit 0
–	–	PT2	PS0	PT1	PX1	PT0	PX0

Table 23. IP register bit definition

Bit	Symbol	R/W	Function
7	–	–	Reserved
6	–	–	Reserved
5 ⁽¹⁾	PT2	R,W	Timer 2 Interrupt priority level
4 ⁽¹⁾	PS0	R,W	UART0 Interrupt priority level
3 ⁽¹⁾	PT1	R,W	Timer 1 Interrupt priority level
2 ⁽¹⁾	PX1	R,W	External Interrupt INT1 priority level
1 ⁽¹⁾	PT0	R,W	Timer 0 Interrupt priority level
0 ⁽¹⁾	PX0	R,W	External Interrupt INT0 priority level

1. 1 = Assigns high priority level, 0 = Assigns low priority level.

Table 24. IPA: Interrupt Priority Addition register (SFR B7h, reset value 00h)

Bit 7	Bit 6	Bit 5	Bit 4	Bit 3	Bit 2	Bit 1	Bit 0
PADC	PSPI	PPCA	PS1	–	–	PI ² C	PUSB

Table 25. IPA register bit definition

Bit	Symbol	R/W	Function
7 ⁽¹⁾	PADC	R,W	ADC Interrupt priority level
6 ⁽¹⁾	PSPI	R,W	SPI Interrupt priority level
5 ⁽¹⁾	PPCA	R,W	PCA Interrupt level
4 ⁽¹⁾	PS1	R,W	UART1 Interrupt priority level
3	–	–	Reserved
2	–	–	Reserved
1 ⁽¹⁾	PI ² C	R,W	I ² C Interrupt priority level
0	PUSB	R,W	USB Interrupt priority level

1. 1 = Assigns high priority level, 0 = Assigns low priority level.

14 MCU clock generation

Internal system clocks generated by the clock generation unit are derived from the signal, XTAL1, shown in [Figure 13](#). XTAL1 has a frequency f_{OSC} , which comes directly from the external crystal or oscillator device. The SFR named CCON0 ([Table 27 on page 70](#)) controls the clock generation unit.

There are two clock signals produced by the clock generation unit:

- MCU_CLK
- PERIPH_CLK

14.1 MCU_CLK

This clock drives the 8032 MCU core and the Watchdog Timer (WDT). The frequency of MCU_CLK is equal to f_{OSC} by default, but it can be divided by as much as 2048, shown in [Figure 13](#). The bits CPUPS[2:0] select one of eight different divisors, ranging from 2 to 2048. The new frequency is available immediately after the CPUPS[2:0] bits are written. The final frequency of MCU_CLK is f_{MCU} .

MCU_CLK is blocked by either bit, PD or IDL, in the SFR named PCON during MCU Power-down mode or Idle mode respectively.

MCU_CLK clock can be further divided as required for use in the WDT. See details of the WDT in [Section 19: Supervisory functions on page 91](#).

14.2 PERIPH_CLK

This clock drives all the UPSD34xx peripherals except the WDT. The Frequency of PERIPH_CLK is always f_{OSC} . Each of the peripherals can independently divide PERIPH_CLK to scale it appropriately for use.

PERIPH_CLK runs at all times except when blocked by the PD bit in the SFR named PCON during MCU Power-down mode.

14.2.1 JTAG interface clock

The JTAG interface for ISP and for Debugging uses the externally supplied JTAG clock, coming in on pin TCK. This means the JTAG ISP interface is always available, and the JTAG Debug interface is available when enabled, even during MCU Idle mode and Power-down mode.

However, since the MCU participates in the JTAG debug process, and MCU_CLK is halted during Idle and Power-down modes, the majority of debug functions are not available during these low power modes. But the JTAG debug interface is capable of executing a reset command while in these low power modes, which will exit back to normal operating mode where all debug commands are available again.

The CCON0 SFR contains a bit, DBGCE, which enables the breakpoint comparators inside the JTAG Debug Unit when set. DBGCE is set by default after reset, and firmware may clear this bit at run-time. Disabling these comparators will reduce current consumption on the MCU module, and it is recommended to do so if the Debug Unit will not be used (such as in the production version of an end-product).

14.2.2 USB_CLK

The UPSD34xx has a dedicated analog phase locked loop (PLL) that can be configured to generate the 48MHz USB_CLK clock on a wide range of f_{OSC} frequencies. The USB_CLK must be at 48MHz for the USB to function properly.

The PLL is enabled after power up. The power on lock time for the PLL clock is about 200µs, and the firmware should wait that much time before enabling the USB_CLK by setting the UPLLCE Bit in the CCON0 register to '1.' The PLL is disabled in Power-down mode, it can also be disabled or enabled by writing to the PLEN Bit in the CCON0 register.

The PLL output clock frequency (f_{USB_CLK}) can be determined by using the following formula:

$$f_{USBCLK} = \frac{[f_{OSC} \times (PLL M + 2)]}{[(PLL D + 2) \times 2]}$$

where PLLM and PLLD are the multiplier and divisor that are specified in the CCON1 register. The f_{OSC}, the PLLM and PLLD range must meet the following conditions to generate a stable USB_CLK:

- a) $-1 \leq PLLM \leq 30$ (binary: $[11111] \leq PLLM[4:0] \leq [11110]$),
- b) $-1 \leq PLLD \leq 14$ (binary: $[1111] \leq PLLD[3:0] \leq [1110]$), and
- c) $f_{OSC}/(PLLD+2)$ must be equal to or greater than 3MHz.

The USB requires a 48MHz clock to operate correctly. The PLLM[4:0] and PLLD[3:0] values must be selected so as to generate a USB_CLK that is as close to 48MHz as possible at different oscillator frequencies (f_{OSC}). [Table 26](#) lists some of the PLLM and PLLD values that can be used on common f_{OSC} frequencies.

Table 26. PLLM and PLLD values for different f_{OSC} frequencies

f _{osc} (MHz)	PLL M[4:0]		PLL D[3:0]		f _{USB_CLK} (MHz)
	decimal	binary	decimal	binary	
40.0	22	10110	8	1000	48.0
36.0	6	00110	1	0001	48.0
33.0	30	11110	9	1001	48.0
30.0	14	01110	3	0011	48.0
24.0	18	10010	3	0011	48.0
16.0	28	11100	3	0011	48.0
12.0	30	11110	2	0010	48.0
8.0	22	10110	0	0000	48.0
6.0	30	11110	0	0000	48.0
3.0	30	11110	-1	1111	48.0

Figure 13. Clock generation logic

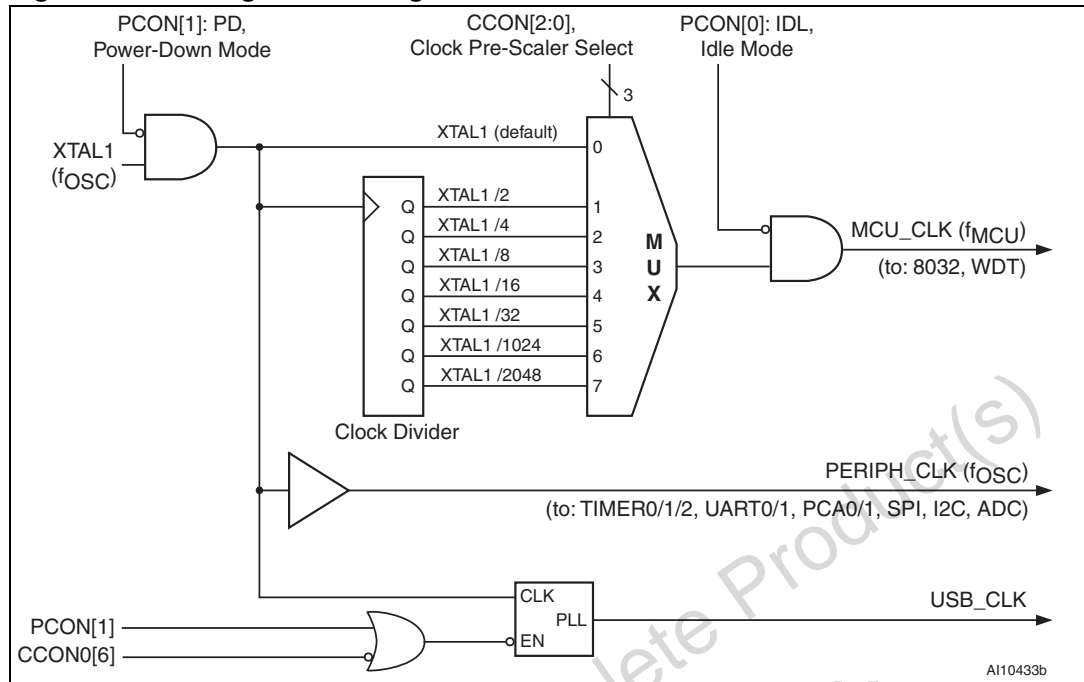

Table 27. CCON0: clock control register (SFR F9h, reset value 50h)

Bit 7	Bit 6	Bit 5	Bit 4	Bit 3	Bit 2	Bit 1	Bit 0
PLLM[4]	PLLEN	UPLLCE	DBGCE	CPUAR	CPUPS[2:0]		

Table 28. CCON0 register bit definition

Bit	Symbol	R/W	Definition
7	PLLM[4]	R,W	Upper bit of the 5-bit PLLM[4:0] Multiplier (Default: '0' for PLLM = 00h)
6	PLLEN	R,W	PLL Enable 0 = Disable PLL operation 1 = Enable PLL operation (Default condition after reset)
5	UPLLCE	R,W	USB Clock Enable 0 = USB clock is disabled (Default condition after reset) 1 = USB clock is enabled
4	DBGCE	R,W	Debug Unit Breakpoint Comparator Enable 0 = JTAG Debug Unit comparators are disabled 1 = JTAG Debug Unit comparators are enabled (Default condition after reset)

Table 28. CCON0 register bit definition (continued)

Bit	Symbol	R/W	Definition
3	CPUAR	R,W	Automatic MCU Clock Recovery 0 = There is no change of CPUPS[2:0] when an interrupt occurs. 1 = Contents of CPUPS[2:0] automatically become 000b whenever any interrupt occurs.
2:0	CPUPS	R,W	MCUCLK Pre-Scaler 000b: $f_{MCU} = f_{OSC}$ (Default after reset) 001b: $f_{MCU} = f_{OSC}/2$ 010b: $f_{MCU} = f_{OSC}/4$ 011b: $f_{MCU} = f_{OSC}/8$ 100b: $f_{MCU} = f_{OSC}/16$ 101b: $f_{MCU} = f_{OSC}/32$ 110b: $f_{MCU} = f_{OSC}/1024$ 111b: $f_{MCU} = f_{OSC}/2048$

Table 29. CCON1 PLL control register (SFR FAh, reset value 00h)

Bit 7	Bit 6	Bit 5	Bit 4	Bit 3	Bit 2	Bit 1	Bit 0
PLLM[3:0]				PLLD[3:0]			

Table 30. CCON1 register bit definition

Bit	Symbol	R/W	Definition
7:4	PLLM[3:0]	R,W	Lower 4 bits of the 5-bit PLLM[4:0] Multiplier (Default after reset: PLLM = 00h) PLLM[4] is in the CCON0 register.
3:0	PLLD[3:0]	R,W	4-bit PLL Divider (Default after reset: PLLD = 0h)

15 Power saving modes

The UPSD34xx is a combination of two die, or modules, each module having its own current consumption characteristics. This section describes reduced power modes for the MCU module. See [Section 28.1.16: Power management on page 197](#) for reduced power modes of the PSD module. Total current consumption for the combined modules is determined in the DC specifications at the end of this document.

The MCU module has three software-selectable modes of reduced power operation.

- Idle mode
- Power-down mode
- Reduced frequency mode

15.1 Idle mode

Idle mode will halt the 8032 MCU core while leaving the MCU peripherals active (Idle mode blocks MCU_CLK only). For lowest current consumption in this mode, it is recommended to disable all unused peripherals, before entering Idle mode (such as the ADC and the Debug Unit breakpoint comparators). The following functions remain fully active during Idle mode (except if disabled by SFR settings).

- External Interrupts INT0 and INT1
- Timer 0, Timer 1 and Timer 2
- Supervisor reset from: LVD, JTAG Debug, External RESET_IN_, but **not** the WTD
- ADC
- I²C Interface
- UART0 and UART1 Interfaces
- SPI Interface
- Programmable Counter Array
- USB Interface

An interrupt generated by any of these peripherals, or a reset generated from the supervisor, will cause Idle mode to exit and the 8032 MCU will resume normal operation.

The output state on I/O pins of MCU ports 1, 3, and 4 remain unchanged during Idle mode.

To enter Idle mode, the 8032 MCU executes an instruction to set the IDL bit in the SFR named PCON, shown in [Table 33 on page 74](#). This is the last instruction executed in normal operating mode before Idle mode is activated. Once in Idle mode, the MCU status is entirely preserved, and there are no changes to: SP, PSW, PC, ACC, SFRs, DATA, IDATA, or XDATA.

The following are factors related to Idle mode exit:

- Activation of any enabled interrupt will cause the IDL bit to be cleared by hardware, terminating Idle mode. The interrupt is serviced, and following the Return from Interrupt instruction (RETI), the next instruction to be executed will be the one which follows the instruction that set the IDL bit in the PCON SFR.
- After a reset from the supervisor, the IDL bit is cleared, Idle mode is terminated, and the MCU restarts after three MCU machine cycles.

15.2 Power-down mode

Power-down mode will halt the 8032 core and all MCU peripherals (Power-down mode blocks MCU_CLK, USB_CLK, and PERIPH_CLK). This is the lowest power state for the MCU module. When the PSD module is also placed in Power-down mode, the lowest total current consumption for the combined die is achieved for the UPSD34xx. See [Section 28.1.16: Power management on page 197](#) in the PSD module section for details on how to also place the PSD module in Power-down mode. The sequence of 8032 instructions is important when placing both modules into Power-down mode.

The instruction that sets the PD Bit in the SFR named PCON ([Table 33 on page 74](#)) is the last instruction executed prior to the MCU module going into Power-down mode. Once in Power-down mode, the on-chip oscillator circuitry and all clocks are stopped. The SFRs, DATA, IDATA, and XDATA are preserved.

Power-down mode is terminated only by a reset from the supervisor, originating from the RESET_IN_ pin, the Low-Voltage Detect circuit (LVD), or a JTAG Debug reset command. Since the clock to the WTD is not active during Power-down mode, it is not possible for the supervisor to generate a WDT reset.

[Table 31 on page 74](#) summarizes the status of I/O pins and peripherals during Idle and Power-down modes on the MCU module. [Table 32 on page 74](#) shows the state of 8032 MCU address, data, and control signals during these modes.

15.3 Reduced frequency mode

The 8032 MCU consumes less current when operating at a lower clock frequency. The MCU can reduce its own clock frequency at run-time by writing to three bits, CPUPS[2:0], in the SFR named CCON0 described in [Table 27 on page 70](#). These bits effectively divide the clock frequency (f_{OSC}) coming in from the external crystal or oscillator device. The clock division range is from 1/2 to 1/2048, and the resulting frequency is f_{MCU} .

This MCU clock division does not affect any of the peripherals, except for the WTD. The clock driving the WTD is the same clock driving the 8032 MCU core as shown in [Figure 13 on page 70](#).

MCU firmware may reduce the MCU clock frequency at run-time to consume less current when performing tasks that are not time critical, and then restore full clock frequency as required to perform urgent tasks.

Returning to full clock frequency is done automatically upon an MCU interrupt, if the CPUAR Bit in the SFR named CCON0 is set (the interrupt will force CPUPS[2:0] = 000). This is an excellent way to conserve power using a low frequency clock until an event occurs that requires full performance. See [Table 27 on page 70](#) for details on CPUAR.

See the DC Specifications at the end of this document to estimate current consumption based on the MCU clock frequency.

Note: Some of the bits in the PCON SFR shown in [Table 33 on page 74](#) are not related to power control.

Table 31. MCU module port and peripheral status during reduced power modes

Mode	Ports 1, 3, 4	SPI, I ² C, UART0,1	PCA, Timer 0,1,2	USB	ADC	EXT INT0,1	Supervisory
Idle	Maintain data	Active	Active	Active	Active	Active	Active ⁽¹⁾
Power-down	Maintain data	Disabled	Disabled	Disabled	Disabled	Disabled	Disabled

1. The Watchdog Timer is not active during Idle mode. Other supervisor functions are active: LVD, external reset, JTAG Debug reset.

Table 32. State of 8032 MCU bus signals during power-down and idle modes

Mode	ALE	PSEN_	RD_	WR_	AD0-7	A8-15
Idle	0	1	1	1	FFh	FFh
Power-down	0	1	1	1	FFh	FFh

Table 33. PCON: power control register (SFR 87h, reset value 00h)

Bit 7	Bit 6	Bit 5	Bit 4	Bit 3	Bit 2	Bit 1	Bit 0
SMOD0	SMOD1	–	POR	RCLK1	TCLK1	PD	IDL

Table 34. PCON register bit definition

Bit	Symbol	R/W	Function
7	SMOD0	R,W	Baud Rate Double Bit (UART0) 0 = No doubling 1 = Doubling (See Section 21.3: UART baud rates on page 110 for details.)
6	SMOD1	R,W	Baud Rate Double Bit for 2nd UART (UART1) 0 = No doubling 1 = Doubling (See Section 21.3: UART baud rates on page 110 for details.)
5	–	–	Reserved
4	POR	R,W	Only a power-on reset sets this bit (cold reset). Warm reset will not set this bit. 0 = Cleared to zero with firmware 1 = Is set only by a power-on reset generated by Supervisory circuit (see Section 19.3: Power-up reset on page 92 for details).
3	RCLK1	R,W	Received Clock Flag (UART1) (See Table 60 on page 101 for flag description.)
2	TCLK1	R,W	Transmit Clock Flag (UART1) (See Table 60 on page 101 for flag description)

Table 34. PCON register bit definition (continued)

Bit	Symbol	R/W	Function
1	PD	R,W	Activate Power-down mode 0 = Not in Power-down mode 1 = Enter Power-down mode
0	IDL	R,W	Activate Idle mode 0 = Not in Idle mode 1 = Enter Idle mode

Obsolete Product(s) - Obsolete Product(s)
Obsolete Product(s) - Obsolete Product(s)

16 Oscillator and external components

The oscillator circuit of UPSD34xx devices is a single stage, inverting amplifier in a Pierce oscillator configuration. The internal circuitry between pins XTAL1 and XTAL2 is basically an inverter biased to the transfer point. Either an external quartz crystal or ceramic resonator can be used as the feedback element to complete the oscillator circuit. Both are operated in parallel resonance. Ceramic resonators are lower cost, but typically have a wider frequency tolerance than quartz crystals. Alternatively, an external clock source from an oscillator or other active device may drive the UPSD34xx oscillator circuit input directly, instead of using a crystal or resonator.

The minimum frequency of the quartz crystal, ceramic resonator, or external clock source is 3MHz if the USB is used. The minimum is 8MHz if I²C is used. The maximum is 40MHz in all cases. This frequency is f_{OSC} , which can be divided internally as described in [Section 14: MCU clock generation on page 68](#).

The pin XTAL1 is the high gain amplifier input, and XTAL2 is the output. To drive the UPSD34xx device externally from an oscillator or other active device, XTAL1 is driven and XTAL2 is left open-circuit. This external source should drive a logic low at the voltage level of $0.3 V_{CC}$ or below, and logic high at $0.7V V_{CC}$ or above, up to $5.5 V V_{CC}$. The XTAL1 input is 5 V tolerant.

Most of the quartz crystals in the range of 25MHz to 40 MHz operate in the third overtone frequency mode. An external LC tank circuit at the XTAL2 output of the oscillator circuit is needed to achieve the third overtone frequency, as shown in [Figure 14 on page 77](#). Without this LC circuit, the crystal will oscillate at a fundamental frequency mode that is about 1/3 of the desired overtone frequency.

Note: *In [Figure 14 on page 77](#) crystals which are specified to operate in fundamental mode (not overtone mode) do not need the LC circuit components. Since quartz crystals and ceramic resonators have their own characteristics based on their manufacturer, it is wise to also consult the manufacturer's recommended values for external components.*

Figure 14. Oscillator and clock connections

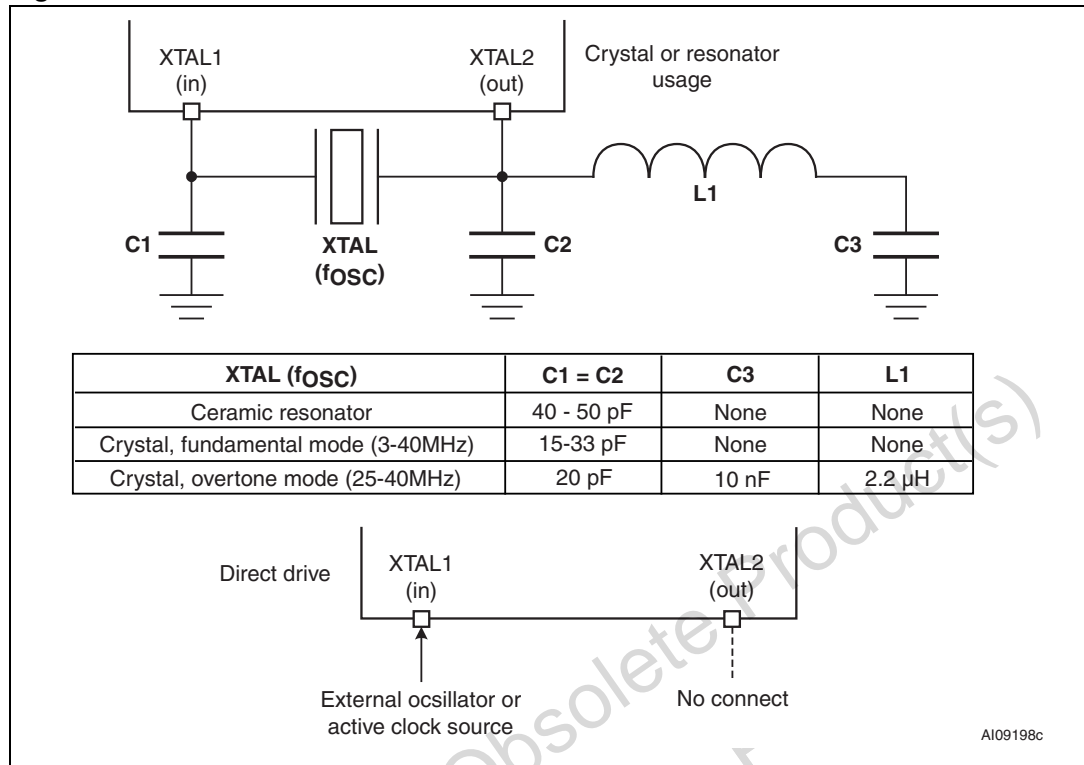

17 I/O ports of mcu module

The MCU module has three 8-bit I/O ports: Port 1, Port 3, and Port 4. The PSD module has four other I/O ports: Port A, B, C, and D. This section describes only the I/O ports on the MCU module.

I/O ports will function as bidirectional general-purpose I/O (GPIO), but the port pins can have alternate functions assigned at run-time by writing to specific SFRs. The default operating mode (during and after reset) for all three ports is GPIO input mode. Port pins that have no external connection will not float because each pin has an internal weak pull-up (~150 k Ω) to V_{CC} .

I/O ports 3 and 4 are 5 V tolerant, meaning they can be driven/pulled externally up to 5.5 V without damage. The pins on Port 4 have a higher current capability than the pins on Ports 1 and 3.

Three additional MCU ports (only on 80-pin UPSD34xx devices) are dedicated to bring out the 8032 MCU address, data, and control signals to external pins. One port, named MCUAD[7:0], has eight multiplexed address/data bidirectional signals. The third port has MCU bus control outputs: read, write, program fetch, and address latch. These ports are typically used to connect external parallel peripherals and memory devices, but they may NOT be used as GPIO. Notice that the eight upper address signals do not come out to pins on the port. If high-order address signals are required on external pins (MCU addresses A[15:8]), then these address signals can be brought out as needed to PLD output pins or to the Address Out mode pins on PSD module ports. See PSD module section, "[Section 28.5.40: Latched address output mode on page 238](#)" for details.

[Figure 15 on page 80](#) represents the flexibility of pin function routing controlled by the SFRs. Each of the 24 pins on three ports, P1, P3, and P4, may be individually routed on a pin-by-pin basis to a desired function.

17.1 MCU port operating modes

MCU port pins can operate as GPIO or as alternate functions (see [Figure 16 on page 80](#) through [Figure 18 on page 81](#)).

Depending on the selected pin function, a particular pin operating mode will automatically be used:

- GPIO - Quasi-bidirectional mode
- UART0, UART1 - Quasi-bidirectional mode
- SPI - Quasi-bidirectional mode
- I2C - Open drain mode
- ADC - Analog input mode
- PCA output - Push-Pull mode
- PCA input - Input only (Quasi-bidirectional)
- Timer 0,1,2 - Input only (Quasi-bidirectional)

17.1.1 GPIO function

Ports in GPIO mode operate as quasi-bidirectional pins, consistent with standard 8051 architecture. GPIO pins are individually controlled by three SFRs:

- SFR, P1 ([Table 35 on page 81](#))
- SFR, P3 ([Table 37 on page 82](#))
- SFR, P4 ([Table 39 on page 82](#))

These SFRs can be accessed using the Bit Addressing mode, an efficient way to control individual port pins.

17.1.2 GPIO output

Simply stated, when a logic '0' is written to a bit in any of these port SFRs while in GPIO mode, the corresponding port pin will enable a low-side driver, which pulls the pin to ground, and at the same time releases the high-side driver and pull-ups, resulting in a logic '0' output. When a logic '1' is written to the SFR, the low-side driver is released, the high-side driver is enabled for just one MCU_CLK period to rapidly make the 0-to-1 transition on the pin, while weak active pull-ups (total ~150K Ω) to V_{CC} are enabled. This structure is consistent with standard 8051 architecture. The high side driver is momentarily enabled only for 0-to-1 transitions, which is implemented with the delay function at the latch output as pictured in [Figure 16 on page 80](#), [Figure 17 on page 81](#), and [Figure 18 on page 81](#). After the high-side driver is disabled, the two weak pull-ups remain enabled resulting in a logic '1' output at the pin, sourcing I_{OH} μ A to an external device. Optionally, an external pull-up resistor can be added if additional source current is needed while outputting a logic '1.'

17.1.3 GPIO input

To use a GPIO port pin as an input, the low-side driver to ground must be disabled, or else the true logic level being driven on the pin by an external device will be masked (always reads logic '0'). So to make a port pin "input ready", the corresponding bit in the SFR must have been set to a logic '1' prior to reading that SFR bit as an input. A reset condition forces SFRs P1, P3, and P4 to FFh, thus all three ports are input ready after reset.

When a pin is used as an input, the stronger pull-up "A" maintains a solid logic '1' until an external device drives the input pin low. At this time, pull-up "A" is automatically disabled, and only pull-up "B" will source the external device I_{IH} μ A, consistent with standard 8051 architecture.

GPIO bidirectional. It is possible to operate individual port pins in bidirectional mode. For an output, firmware would simply write the corresponding SFR bit to logic '1' or '0' as needed. But before using the pin as an input, firmware must first ensure that a logic '1' was the last value written to the corresponding SFR bit prior to reading that SFR bit as an input.

GPIO current capability. A GPIO pin on Port 4 can sink twice as much current than a pin on either Port 1 or Port 3 when the low-side driver is outputting a logic '0' (I_{OL}). See the DC specifications at the end of this document for full details.

Reading port pin vs. reading port latch. When firmware reads the GPIO ports, sometimes the actual port pin is sampled in hardware, and sometimes the port SFR latch is read and not the actual pin, depending on the type of MCU instruction used. These two data paths are shown in [Figure 16 on page 80](#) through [Figure 18 on page 81](#). SFR latches are read (and not the pins) only when the read is part of a *read-modify-write* instruction and the write destination is a bit or bits in a port SFR. These instructions are: ANL, ORL, XRL, JBC,

CPL, INC, DEC, DJNZ, MOV, CLR, and SETB. All other types of reads to port SFRs will read the actual pin logic level and not the port latch. This is consistent with 8051 architecture.

Figure 15. MCU module port pin function routing

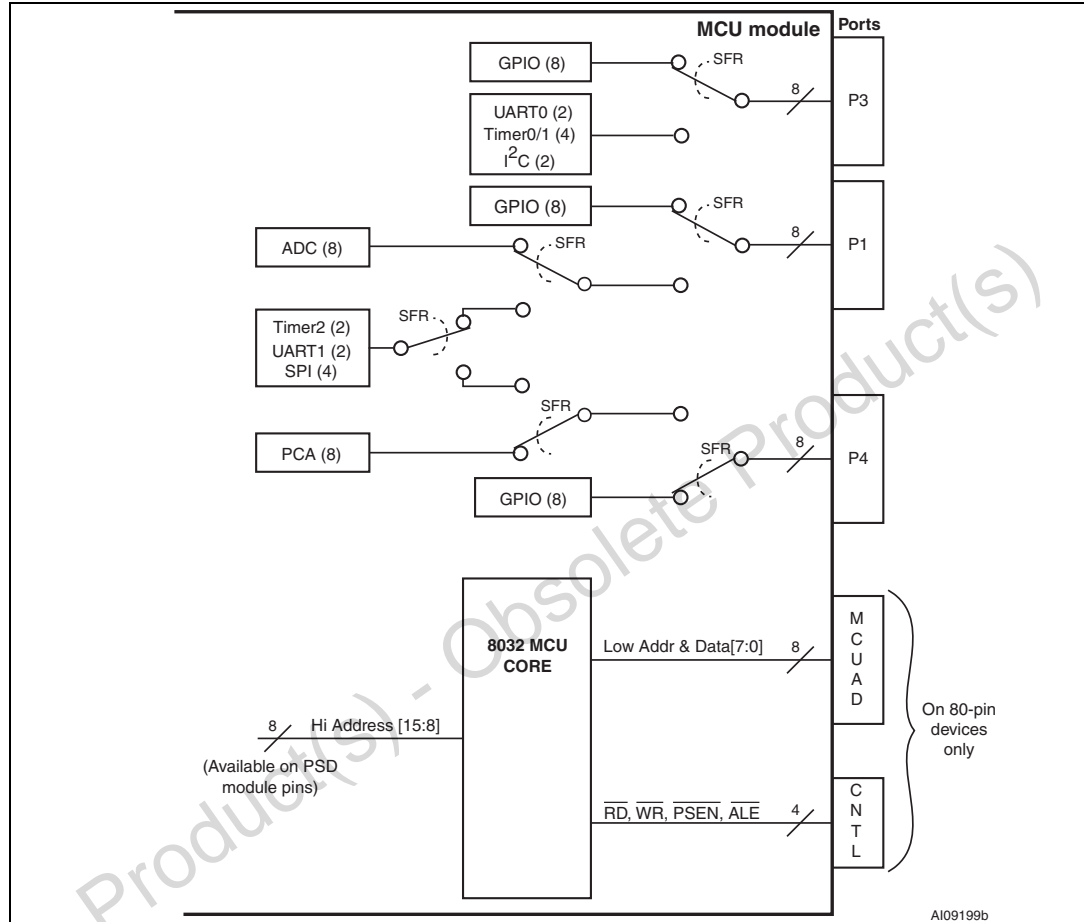

Figure 16. MCU I/O cell block diagram for port 1

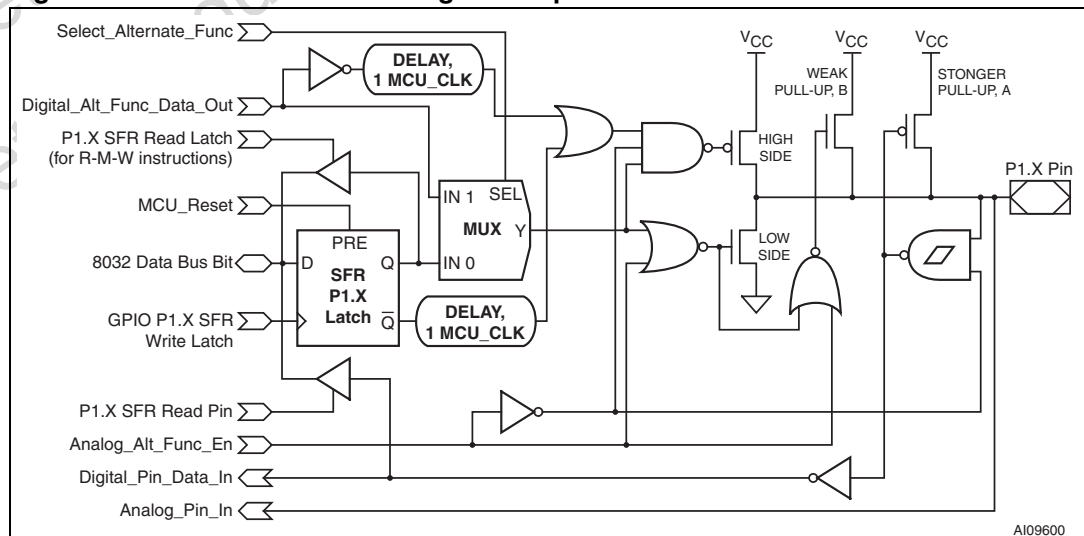

Figure 17. MCU I/O cell block diagram for port 3

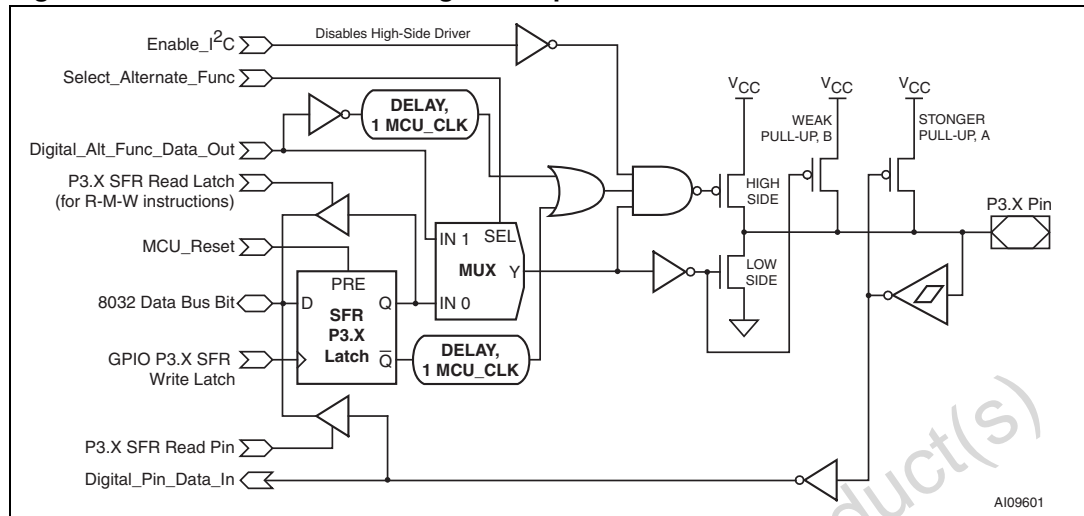

Figure 18. MCU I/O cell block diagram for port 4

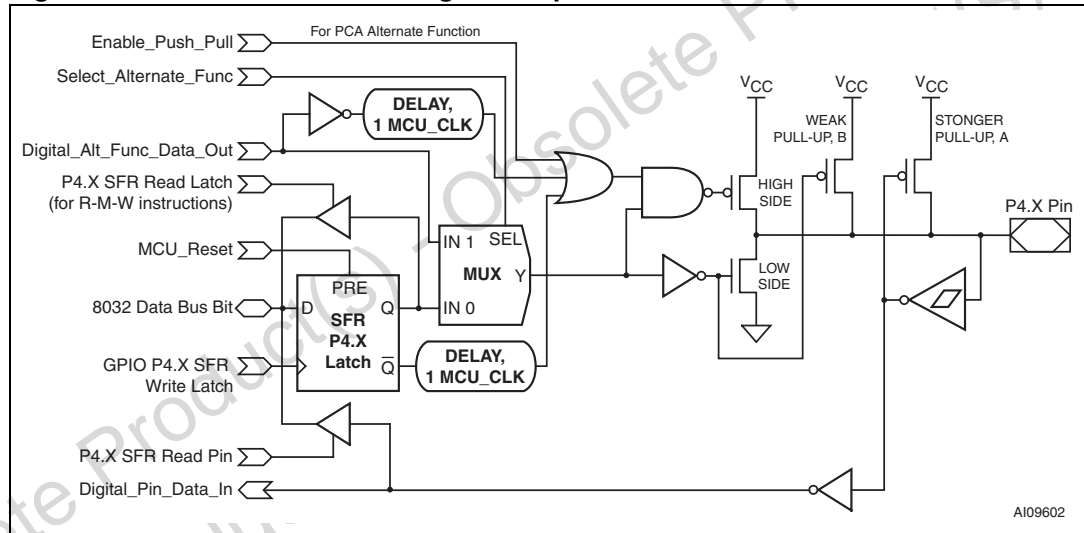

Table 35. P1: I/O port 1 register (SFR 90h, reset value FFh)

Bit 7	Bit 6	Bit 5	Bit 4	Bit 3	Bit 2	Bit 1	Bit 0
P1.7	P1.6	P1.5	P1.4	P1.3	P1.2	P1.1	P1.0

Table 36. P1 register bit definition

Bit	Symbol	R/W	Function ⁽¹⁾
7	P1.7	R,W	Port pin 1.7
6	P1.6	R,W	Port pin 1.6
5	P1.5	R,W	Port pin 1.5
4	P1.4	R,W	Port pin 1.4
3	P1.3	R,W	Port pin 1.3

Table 36. P1 register bit definition (continued)

Bit	Symbol	R/W	Function ⁽¹⁾
2	P1.2	R,W	Port pin 1.2
1	P1.1	R,W	Port pin 1.1
0	P1.0	R,W	Port pin 1.0

1. Write '1' or '0' for pin output. Read for pin input, but prior to READ, this bit must have been set to '1' by firmware or by a reset event.

Table 37. P3: I/O port 3 register (SFR B0h, reset value FFh)

Bit 7	Bit 6	Bit 5	Bit 4	Bit 3	Bit 2	Bit 1	Bit 0
P3.7	P3.6	P3.5	P3.4	P3.3	P3.2	P3.1	P3.0

Table 38. P3 register bit definition

Bit	Symbol	R/W	Function ⁽¹⁾
7	P3.7	R,W	Port pin 3.7
6	P3.6	R,W	Port pin 3.6
5	P3.5	R,W	Port pin 3.5
4	P3.4	R,W	Port pin 3.4
3	P3.3	R,W	Port pin 3.3
2	P3.2	R,W	Port pin 3.2
1	P3.1	R,W	Port pin 3.1
0	P3.0	R,W	Port pin 3.0

1. Write '1' or '0' for pin output. Read for pin input, but prior to READ, this bit must have been set to '1' by firmware or by a reset event.

Table 39. P4: I/O port 4 register (SFR C0h, reset value FFh)

Bit 7	Bit 6	Bit 5	Bit 4	Bit 3	Bit 2	Bit 1	Bit 0
P4.7	P4.6	P4.5	P4.4	P4.3	P4.2	P4.1	P4.0

Table 40. P4 register bit definition

Bit	Symbol	R/W	Function ⁽¹⁾
7	P4.7	R,W	Port pin 4.7
6	P4.6	R,W	Port pin 4.6
5	P4.5	R,W	Port pin 4.5
4	P4.4	R,W	Port pin 4.4
3	P4.3	R,W	Port pin 4.3
2	P4.2	R,W	Port pin 4.2
1	P4.1	R,W	Port pin 4.1
0	P4.0	R,W	Port pin 4.0

1. Write '1' or '0' for pin output. Read for pin input, but prior to READ, this bit must have been set to '1' by firmware or by a reset event.

17.1.4 Alternate functions

There are five SFRs used to control the mapping of alternate functions onto MCU port pins, and these SFRs are depicted as switches in [Figure 15 on page 80](#).

- Port 3 uses the SFR, P3SFS ([Table 41 on page 84](#)).
- Port 1 uses SFRs, P1SFS0 ([Table 43 on page 84](#)) and P1SFS1 ([Table 44 on page 84](#)).
- Port 4 uses SFRs, P4SFS0 ([Table 46 on page 85](#)) and P4SFS1 ([Table 47 on page 85](#)).

Since these SFRs are cleared by a reset, then by default all port pins function as GPIO (not the alternate function) until firmware initializes these SFRs.

Each pin on each of the three ports can be independently assigned a different function on a pin-by-pin basis.

The peripheral functions Timer 2, UART1, and I²C may be split independently between Port 1 and Port 4 for additional flexibility by giving a wider choice of peripheral usage on a limited number of device pins.

When the selected alternate function is UART0, UART1, or SPI, then the related pins are in quasi-bidirectional mode, including the use of the high-side driver for rapid 0-to-1 output transitions. The high-side driver is enabled for just one MCU_CLK period on 0-to-1 transitions by the delay function at the “digital_alt_func_data_out” signal pictured in [Figure 16 on page 80](#) through [Figure 18 on page 81](#).

If the alternate function is Timer 0, Timer 1, Timer 2, or PCA input, then the related pins are in quasi-bidirectional mode, but input only.

If the alternate function is ADC, then for each pin the pull-ups, the high-side driver, and the low-side driver are disabled. The analog input is routed directly to the ADC unit. Only Port 1 supports analog functions ([Figure 16 on page 80](#)). Port 1 is not 5 V tolerant.

If the alternate function is I²C, the related pins will be in open drain mode, which is just like quasi-bidirectional mode but the high-side driver is not enabled for one cycle when outputting a 0-to-1 transition. Only the low-side driver and the internal weak pull-ups are used. Only Port 3 supports open-drain mode ([Figure 17 on page 81](#)). I²C requires the use of an external pull-up resistor on each bus signal, typically 4.7KΩ to V_{CC}.

If the alternate function is PCA output, then the related pins are in push-pull mode, meaning the pins are actively driven and held to logic '1' by the high-side driver, or actively driven and held to logic '0' by the low-side driver. Only Port 4 supports push-pull mode ([Figure 18 on page 81](#)). Port 4 push-pull pins can source I_{OH} current when driving logic '1,' and sink I_{OL} current when driving logic '0.' This current is significantly more than the capability of pins on Port 1 or Port 3 (see [Table 211 on page 271](#)).

For example, to assign these port functions:

- Port 1: UART1, ADC[1:0], P1[7:4] are GPIO
- Port 3: UART0, I²C, P3[5:2] are GPIO
- Port 4: TCM0, SPI, P4[3:1] are GPIO

The following values need to be written to the SFRs:

```
P1SFS0 = 00001111b, or 0Fh
P1SFS1 = 00000011b , or 03h
P3SFS = 11000011b, or C3h
P4SFS0 = 11110001b, or F1h
P4SFS1 = 11110000b, or F0h
```

Table 41. P3SFS: Port 3 special function select register (SFR 91h, reset value 00h)

Bit 7	Bit 6	Bit 5	Bit 4	Bit 3	Bit 2	Bit 1	Bit 0
P3SFS7	P3SFS6	P3SFS5	P3SFS4	P3SFS3	P3SFS2	P3SFS1	P3SFS0

Table 42. P3SFS register bit definition

Port 3 Pin	R/W	Default port function	Alternate port function
		P3SFS[i] - 0; Port 3 Pin, i = 0..7	P3SFS[i] - 1; Port 3 Pin, i = 0..7
0	R,W	GPIO	UART0 Receive, RXD0
1	R,W	GPIO	UART0 Transmit, TXD0
2	R,W	GPIO	Ext Intr 0/Timer 0 Gate, EXT0INT/TG0
3	R,W	GPIO	Ext Intr 1/Timer 1 Gate, EXT1INT/TG1
4	R,W	GPIO	Counter 0 Input, C0
5	R,W	GPIO	Counter 0 Input, C1
6	R,W	GPIO	I ² C Data, I2CSDA
7	R,W	GPIO	I ² C Clock, I2CCL

Table 43. P1SFS0: Port 1 special function select 0 register (SFR 8Eh, reset value 00h)

Bit 7	Bit 6	Bit 5	Bit 4	Bit 3	Bit 2	Bit 1	Bit 0
P1SF07	P1SF06	P1SF05	P1SF04	P1SF03	P1SF02	P1SF01	P1SF00

Table 44. P1SFS1: Port 1 special function select 1 register (SFR 8Fh, reset value 00h)

Bit 7	Bit 6	Bit 5	Bit 4	Bit 3	Bit 2	Bit 1	Bit 0
P1SF17	P1SF16	P1SF15	P1SF14	P1SF13	P1SF12	P1SF11	P1SF10

Table 45. P1SFS0 and P1SFS1 details

Port 1 Pin	R/W	Default port function	Alternate 1 port function	Alternate 2 port function
		P1SFS0[i] = 0 P1SFS1[i] = x	P1SFS0[i] = 1 P1SFS1[i] = 0	P1SFS0[i] = 1 P1SFS1[i] = 1
		Port 1 Pin, i = 0.. 7	Port 1 Pin, i = 0.. 7	Port 1 Pin, i = 0.. 7
0	R,W	GPIO	Timer 2 count input, T2	ADC Chn 0 input, ADC0
1	R,W	GPIO	Timer 2 trigger input, TX2	ADC Chn 1 input, ADC1
2	R,W	GPIO	UART1 Receive, RXD1	ADC Chn 2 input, ADC2
3	R,W	GPIO	UART1 Transmit, TXD1	ADC Chn 3 input, ADC3
4	R,W	GPIO	SPI Clock, SPICLK	ADC Chn 4 input, ADC4
5	R,W	GPIO	SPI Receive, SPIRXD	ADC Chn 5 input, ADC5

Table 45. P1SFS0 and P1SFS1 details (continued)

Port 1 Pin	R/W	Default port function	Alternate 1 port function	Alternate 2 port function
		P1SFS0[i] = 0 P1SFS1[i] = x	P1SFS0[i] = 1 P1SFS1[i] = 0	P1SFS0[i] = 1 P1SFS1[i] = 1
		Port 1 Pin, i = 0.. 7	Port 1 Pin, i = 0.. 7	Port 1 Pin, i = 0.. 7
6	R,W	GPIO	SPI Transmit, SPITXD	ADC Chn 6 input, ADC6
7	R,W	GPIO	SPI Select, SPISEL_	ADC Chn 7 input, ADC7

Table 46. P4SFS0: Port 4 special function select 0 register (SFR 92h, reset value 00h)

Bit 7	Bit 6	Bit 5	Bit 4	Bit 3	Bit 2	Bit 1	Bit 0
P4SF07	P4SF06	P4SF05	P4SF04	P4SF03	P4SF02	P4SF01	P4SF00

Table 47. P4SFS1: Port 4 special function select 1 register (SFR 93h, reset value 00h)

Bit 7	Bit 6	Bit 5	Bit 4	Bit 3	Bit 2	Bit 1	Bit 0
P4SF17	P4SF16	P4SF15	P4SF14	P4SF13	P4SF12	P4SF11	P4SF10

Table 48. P4SFS0 and P4SFS1 details

Port 4 pin	R/W	Default port function	Alternate 1 port function	Alternate 2 port function
		P4SFS0[i] = 0 P4SFS1[i] = x	P4SFS0[i] = 1 P4SFS1[i] = 0	P4SFS0[i] = 1 P4SFS1[i] = 1
		Port 4 Pin, i = 0.. 7	Port 4 Pin, i = 0.. 7	Port 4 Pin, i = 0.. 7
0	R,W	GPIO	PCA0 Module 0, TCM0	Timer 2 count input, T2
1	R,W	GPIO	PCA0 Module 1, TCM1	Timer 2 trigger input, TX2
2	R,W	GPIO	PCA0 Module 2, TCM2	UART1 Receive, RXD1
3	R,W	GPIO	PCA0 ext clock, PCACLK0	UART1 Transmit, TXD1
4	R,W	GPIO	PCA1 Module 3, TCM3	SPI Clock, SPICLK
5	R,W	GPIO	PCA1 Module 4, TCM4	SPI Receive, SPIRXD
6	R,W	GPIO	PCA1 Module 5, TCM5	SPI Transmit, SPITXD
7	R,W	GPIO	PCA1 ext clock, PCACLK1	SPI Select, SPISEL_

18 MCU bus interface

The MCU module has a programmable bus interface which is a modified 8032 bus with 16 multiplexed address and data lines. The bus supports four types of data transfer (16- or 8-bit), each transfer is to/from a memory location external to the MCU module:

- Code Fetch cycle using the PSEN signal: fetch a 16-bit code word for filling the pre-fetch queue. The CPU fetches a code byte from the PFQ for execution;
- Code Read cycle using PSEN: read a 16-bit code word using the MOVC (Move Constant) instruction. The code word is routed directly to the CPU and by-pass the PFQ;
- XDATA Read cycle using the RD signal: read a data byte using the MOVX (Move eXternal) instruction; and
- XDATA Write cycle using the WR signal: write a data byte using the MOVX instruction

18.1 PSEN bus cycles

In a PSEN bus cycle, the MCU module fetches the instruction from the 16-bit program memory in the PSD module. The multiplexed address/data bus AD[15:0] is connected to the PSD module for 16-bit data transfer. The UPSD34xx does not support external PSEN cycles and cannot fetch instruction from other external program memory devices.

18.2 READ or WRITE bus cycles

In an XDATA READ or WRITE bus cycle, the MCU's multiplexed AD[15:0] bus is connected to the PSD module, but only the lower bytes AD[7:0] are used for the 8-bit data transfer. The AD[7:0] lines are also connected to pins in the 80-pin package for accessing external devices. If the high address byte A[15:8] is needed for external devices, Port B in the PSD module can be configured to provide the latched A[15:8] address outputs.

18.3 Connecting external devices to the MCU bus

The UPSD34xx supports 8-bit only external I/O or Data memory devices. The READ and WRITE data transfer is carried out on the AD[7:0] bus which is available in the 80-pin package. The address lines can be brought out to the external devices in one of three ways:

1. Configure Ports B and A of the PSD module in Address Output mode, as shown in [Figure 19](#);
2. Use Port B together with an external latch, as shown in [Figure 20 on page 87](#). The external latch latches the low address byte from the AD[7:0] bus with the ALE signal. This configuration is for design where Port A is needed for CPLD functions; and
3. Configure the microcell in the CPLD to output any address line to any of the CPLD output pins. This is the most flexible implementation but requires the use of CPLD resources.

Ports A and B in the PSD module can be configured in the PSDsoft to provide latched MCU address A[7:0] and A[15:8] (see [Section 28.5: PSD module detailed operation on page 207](#) for details on how to enable Address Output mode). The latched address outputs on the ports are pin configurable. For example, Port B pins PB[2:0] can be enabled to provide

A[10:8] and the remaining pins can be configured for other functions such as generating chip selects to the external devices.

Figure 19. Connecting external devices using ports A and B for address AD[15:0]

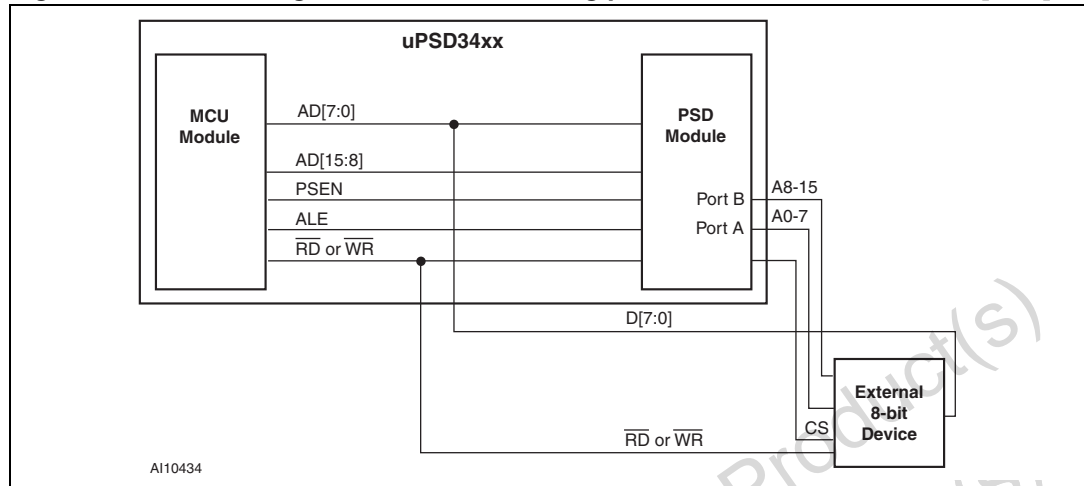
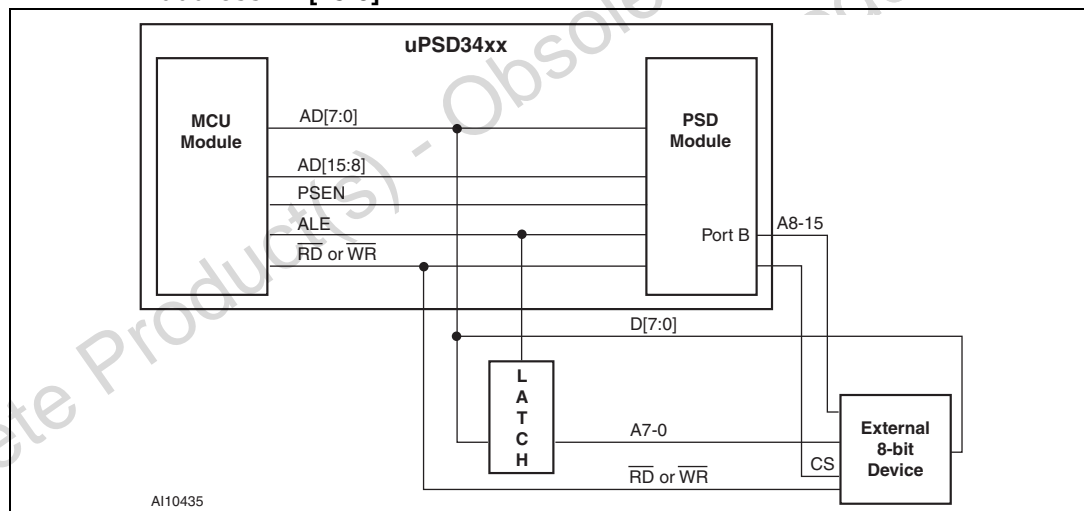

Figure 20. Connecting external devices using port A and an external latch for address AD[15:0]



18.4 Programmable bus timing

The length of the bus cycles are user programmable at run time. The number of MCU_CLK periods in a bus cycle can be specified in the SFR register named BUSCON (see [Table 49 on page 88](#)). By default, the BUSCON register is loaded with long bus cycle times (6 MCU_CLK periods) after a reset condition. It is important that the post-reset initialization firmware sets the bus cycle times appropriately to get the most performance, according to [Table 51 on page 90](#). Keep in mind that the PSD module has a faster Turbo mode (default) and a slower but less power consuming Non-Turbo mode. The bus cycle times must be programmed in BUSCON to optimize for each mode as shown in [Table 51](#). See [Section 28.5: PSD module detailed operation on page 207](#) for more details.

It is not possible to specify in the BUSCON register a different number of MCU_CLK periods for various address ranges. For example, the user cannot specify 4 MCU_CLK periods for RD read cycles to one address range on the PSD module, and 5 MCU_CLK periods for RD read cycles to a different address range on an external device. However, the user can specify one number of clock periods for PSEN read cycles and a different number of clock periods for RD or WR cycles (see [Figure 21 on page 88](#)).

18.5 Controlling the PFQ and BC

The BUSCON register allows firmware to enable and disable the PFQ and BC at run-time. Sometimes it may be desired to disable the PFQ and BC to ensure deterministic execution. The dynamic action of the PFQ and BC may cause varying program execution times depending on the events that happen prior to a particular section of code of interest. For this reason, it is not recommended to implement timing loops in firmware, but instead use one of the many hardware timers in the UPSD34xx. By default, the PFQ and BC are enabled after a reset condition.

Important note: Disabling the PFQ or BC will seriously reduce MCU performance.

Figure 21. A RD or PSEN bus cycle set to 5 MCU_CLK

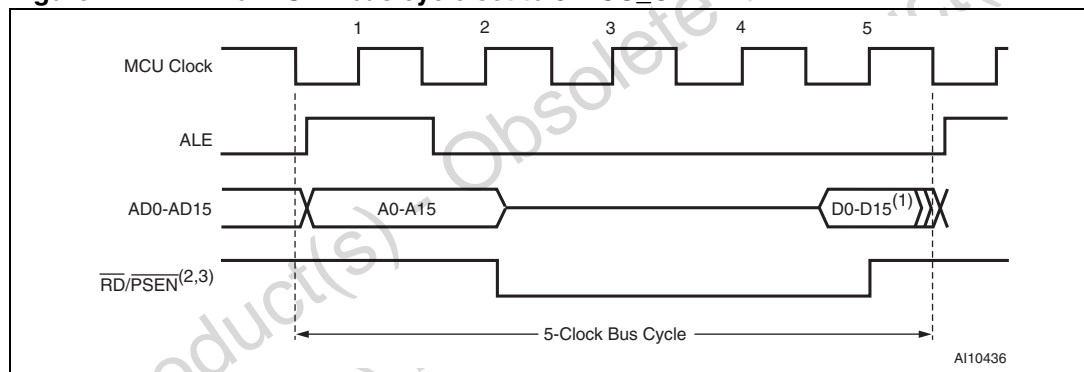

1. The PSEN cycle is 16-bit, while the RD cycle is 8-bit only.
2. A PSEN bus cycle in progress may be aborted before completion if the PFQ and Branch Cache (BC) determines the current code fetch cycle is not needed.
3. Whenever the same number of MCU_CLK periods is specified in BUSCON for both PSEN and RD cycles, the bus cycle timing is typically identical for each of these types of bus cycles. In this case, the only time PSEN read cycles are longer than RD read cycles is when the PFQ issues a stall while reloading. PFQ stalls do not affect RD read cycles. By comparison, in many traditional 8051 architectures, RD bus cycles are always longer than PSEN bus cycles.

Table 49. BUSCON: bus control register (SFR 9Dh, reset value EBh)

Bit 7	Bit 6	Bit 5	Bit 4	Bit 3	Bit 2	Bit 1	Bit 0
EPFQ	EBC	WRW[1:0]		RDW[1:0]		CW[1:0]	

Table 50. BUSCON register bit definition

Bit	Symbol	R/W	Definition
7	EPFQ	R,W	Enable pre-fetch queue 0 = PFQ is disabled 1 = PFQ is enabled (default)
6	EBC	R,W	Enable branch cache 0 = BC is disabled 1 = BC is enabled (default)
5:4	WRW[1:0]	R,W	\overline{WR} Wait, number of MCU_CLK periods for \overline{WR} write bus cycle during any MOVX instruction 00b: 4 clock periods 01b: 5 clock periods 10b: 6 clock periods (default) 11b: 7 clock periods
3:2	RDW[1:0]	R,W	\overline{RD} Wait, number of MCU_CLK periods for \overline{RD} read bus cycle during any MOVX instruction 00b: 4 clock periods 01b: 5 clock periods 10b: 6 clock periods (default) 11b: 7 clock periods
1:0	CW[1:0]	R,W	Code Wait, number of MCU_CLK periods for \overline{PSEN} read bus cycle during any code byte fetch or during any MOVC code byte read instruction. Periods will increase with PFQ stall 00b: 3 clock periods - exception, for MOVC instructions this setting results 4 clock periods 01b: 4 clock periods 10b: 5 clock periods 11b: 6 clock periods (default)

Obsolete Product(s)
Obsolete Product(s)

Table 51. Number of MCU_CLK periods required to optimize bus transfer rate

MCU clock frequency, MCU_CLK (f_{MCU})	CW[1:0] Cik periods		RDW[1:0] Cik periods		WRW[1:0] Cik periods	
	3.3 V ⁽¹⁾	5 V ⁽¹⁾	3.3 V ⁽¹⁾	5 V ⁽¹⁾	3.3 V ⁽¹⁾	5 V ⁽¹⁾
40 MHz, Turbo mode PSD ⁽²⁾	5	4	5	4	5	4
40 MHz, Non-turbo mode PSD	6	5	6	5	6	5
36 MHz, Turbo mode PSD	5	4	5	4	5	4
36 MHz, Non-turbo mode PSD	6	4	6	4	6	4
32 MHz, Turbo mode PSD	5	4	5	4	5	4
32 MHz, Non-turbo mode PSD	5	4	5	4	5	4
28 MHz, Turbo mode PSD	4	3	4	4	4	4
28 MHz, Non-turbo mode PSD	5	4	5	4	5	4
24MHz, Turbo mode PSD	4	3	4	4	4	4
24MHz, Non-turbo mode PSD	4	3	4	4	4	4
20 MHz and below, Turbo mode PSD	3	3	4	4	4	4
20 MHz and below, Non-turbo mode PSD	3	3	4	4	4	4

1. V_{DD} of the PSD module.
2. "Turbo mode PSD" means that the PSD module is in the faster, Turbo mode (default condition). A PSD module in Non-Turbo mode is slower, but consumes less current. See PSD module section, titled "PLD Non-Turbo mode" for details.

19 Supervisory functions

Supervisory circuitry on the MCU module will issue an internal reset signal to the MCU module and simultaneously to the PSD module as a result of any of the following four events:

- The external $\overline{\text{RESET_IN}}$ pin is asserted
- The low-voltage detect (LVD) circuitry has detected a voltage on V_{CC} below a specific threshold (power-on or voltage sags)
- The JTAG debug interface has issued a reset command
- The watchdog timer (WDT) has timed out

The resulting internal reset signal, MCU_RESET , will force the 8032 into a known reset state while asserted, and then 8032 program execution will jump to the reset vector at program address 0000h just after MCU_RESET is deasserted. The MCU module will also assert an active low internal reset signal, $\overline{\text{RESET}}$, to the PSD module. If needed, the signal $\overline{\text{RESET}}$ can be driven out to external system components through any PLD output pin on the PSD module. When driving this “RESET_OUT” signal from a PLD output, the user can choose to make it either active-high or active-low logic, depending on the PLD equation.

19.1 External reset input pin, $\overline{\text{RESET_IN}}$

The $\overline{\text{RESET_IN}}$ pin can be connected directly to a mechanical reset switch or other device which pulls the signal to ground to invoke a reset.

$\overline{\text{RESET_IN}}$ is pulled up internally and enters a Schmitt trigger input buffer with a voltage hysteresis of $V_{\text{RST_HYS}}$ for immunity to the effects of slow signal rise and fall times, as shown in [Figure 22](#). $\overline{\text{RESET_IN}}$ is also filtered to reject a voltage spike less than a duration of $t_{\text{RST_FIL}}$. The $\overline{\text{RESET_IN}}$ signal must be maintained at a logic '0' for at least a duration of $t_{\text{RST_LO_IN}}$ while the oscillator is running. The resulting MCU_RESET signal will last only as long as the $\overline{\text{RESET_IN}}$ signal is active (it is not stretched). Refer to the Supervisor AC specifications in [Table 233 on page 286](#) at the end of this document for these parameter values.

Figure 22. Supervisor reset generation

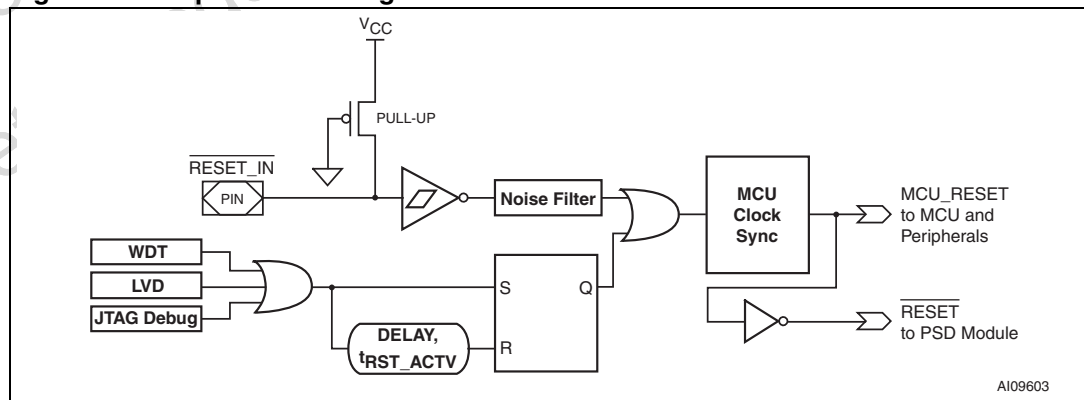

19.2 Low V_{CC} voltage detect, LVD

An internal reset is generated by the LVD circuit when V_{CC} drops below the reset threshold, V_{LV_THRESH} . After V_{CC} returns to the reset threshold, the MCU_RESET signal will remain asserted for t_{RST_ACTV} before it is released. The LVD circuit is always enabled (cannot be disabled by SFR), even in Idle mode and Power-down mode. The LVD input has a voltage hysteresis of V_{RST_HYS} and will reject voltage spikes less than a duration of t_{RST_FIL} .

Important note: The LVD voltage threshold is V_{LV_THRESH} , suitable for monitoring both the 3.3 V V_{CC} supply on the MCU module and the 3.3 V V_{DD} supply on the PSD module for 3.3 V UPSD34xxV devices, since these supplies are one in the same on the circuit board.

However, for 5 V UPSD34xx devices, V_{LV_THRESH} is not suitable for monitoring the 5 V V_{DD} voltage supply (V_{LV_THRESH} is too low), but good for monitoring the 3.3 V V_{CC} supply. In the case of 5 V UPSD34xx devices, an external means is required to monitor the separate 5 V V_{DD} supply, if desired.

19.3 Power-up reset

At power up, the internal reset generated by the LVD circuit is latched as a logic '1' in the POR bit of the SFR named PCON ([Table 33 on page 74](#)). Software can read this bit to determine whether the last MCU reset was the result of a power up (cold reset) or a reset from some other condition (warm reset). This bit must be cleared with software.

19.4 JTAG debug reset

The JTAG Debug Unit can generate a reset for debugging purposes. This reset source is also available when the MCU is in Idle mode and Power-Down mode (the user can use the JTAG debugger to exit these modes).

19.5 Watchdog timer, WDT

When enabled, the WDT will generate a reset whenever it overflows. Firmware that is behaving correctly will periodically clear the WDT before it overflows. Run-away firmware will not be able to clear the WDT, and a reset will be generated.

By default, the WDT is disabled after each reset.

Note: The WDT is not active during Idle mode or Power-down mode.

There are two SFRs that control the WDT, they are $WDKEY$ ([Table 52 on page 94](#)) and $WDRST$ ([Table 54 on page 94](#)).

If $WDKEY$ contains 55h, the WDT is disabled. Any value other than 55h in $WDKEY$ will enable the WDT. By default, after any reset condition, $WDKEY$ is automatically loaded with 55h, disabling the WDT. It is the responsibility of initialization firmware to write some value other than 55h to $WDKEY$ after each reset if the WDT is to be used.

The WDT consists of a 24-bit up-counter ([Figure 23](#)), whose initial count is 000000h by default after every reset. The most significant byte of this counter is controlled by the SFR, $WDRST$. After being enabled by $WDKEY$, the 24-bit count is increased by 1 for each MCU machine cycle. When the count overflows beyond FFFFh (2^{24} MCU machine cycles), a reset is issued and the WDT is automatically disabled ($WDKEY = 55h$ again).

To prevent the WDT from timing out and generating a reset, firmware must repeatedly write some value to WDRST before the count reaches FFFFFh. Whenever WDRST is written, the upper 8 bits of the 24-bit counter are loaded with the written value, and the lower 16 bits of the counter are cleared to 0000h.

The WDT time-out period can be adjusted by writing a value other than 00h to WDRST. For example, if WDRST is written with 04h, then the WDT will start counting 040000h, 040001h, 040002h, and so on for each MCU machine cycle. In this example, the WDT time-out period is shorter than if WDRST was written with 00h, because the WDT is an up-counter. A value for WDRST should never be written that results in a WDT time-out period shorter than the time required to complete the longest code task in the application, else unwanted WDT overflows will occur.

Figure 23. Watchdog counter

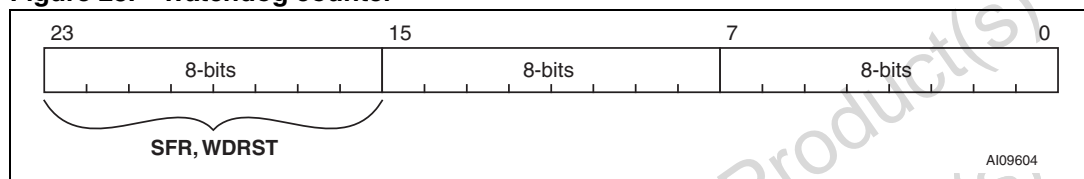

The formula to determine WDT time-out period is:

$$WDT_{PERIOD} = t_{MACH_CYC} \times N_{OVERFLOW}$$

$N_{OVERFLOW}$ is the number of WDT up-counts required to reach FFFFFh. This is determined by the value written to the SFR, WDRST.

t_{MACH_CYC} is the average duration of one MCU machine cycle. By default, an MCU machine cycle is always 4 MCU_CLK periods for UPSD34xx, but the following factors can sometimes add more MCU_CLK periods per machine cycle:

- The number of MCU_CLK periods assigned to MCU memory bus cycles as determined in the SFR, BUSCON. If this setting is greater than 4, then machine cycles have additional MCU_CLK periods during memory transfers.
- Whether or not the PFQ/BC circuitry issues a stall during a particular MCU machine cycle. A stall adds more MCU_CLK periods to a machine cycle until the stall is removed.

t_{MACH_CYC} is also affected by the absolute time of a single MCU_CLK period. This number is fixed by the following factors:

- Frequency of the external crystal, resonator, or oscillator: (f_{OSC})
- Bit settings in the SFR CCON0, which can divide f_{OSC} and change MCU_CLK

As an example, assume the following:

1. f_{OSC} is 40MHz, thus its period is 25ns.
2. CCON0 is 10h, meaning no clock division, so the period of MCU_CLK is also 25ns.
3. BUSCON is C1h, meaning the PFQ and BC are enabled, and each MCU memory bus cycle is 4 MCU_CLK periods, adding no additional MCU_CLK periods to MCU machine cycles during memory transfers.
4. Assume there are no stalls from the PFQ/BC. In reality, there are occasional stalls but their occurrence has minimal impact on WDT timeout period.
5. WDRST contains 00h, meaning a full 2^{24} up-counts are required to reach FFFFFh and generate a reset.

In this example,

$$t_{MACH_CYC} = 100ns \text{ (4 MCU_CLK periods x 25ns)}$$

$$N_{OVERFLOW} = 2^{24} = 16777216 \text{ up-counts}$$

$$WDT_{PERIOD} = 100ns \times 16777216 = 1.67 \text{ seconds}$$

The actual value will be slightly longer due to PFQ/BC.

19.5.1 Firmware example

The following 8051 assembly code illustrates how to operate the WDT. A simple statement in the reset initialization firmware enables the WDT, and then a periodic write to clear the WDT in the main firmware is required to keep the WDT from overflowing. This firmware is based on the example above (40MHz f_{OSC} , CCON0 = 10h, BUSCON = C1h).

For example, in the reset initialization firmware (the function that executes after a jump to the reset vector):

```
MOV AE, #AA ; enable WDT by writing value to
              ; WDKEY other than 55h
```

Somewhere in the flow of the main program, this statement will execute periodically to reset the WDT before its time-out period of 1.67 seconds. For example:

```
MOV A6, #00 ; reset WDT, loading 000000h.
              ; Counting will automatically
              ; resume as long as 55h in not in
              ; WDKEY
```

Table 52. WDKEY: Watchdog timer key register (SFR AEh, reset value 55h)

Bit 7	Bit 6	Bit 5	Bit 4	Bit 3	Bit 2	Bit 1	Bit 0
WDKEY[7:0]							

Table 53. WDKEY register bit definition

Bit	Symbol	R/W	Definition
[7:0]	WDKEY	W	55h disables the WDT from counting. 55h is automatically loaded in this SFR after any reset condition, leaving the WDT disabled by default. Any value other than 55h written to this SFR will enable the WDT, and counting begins.

Table 54. WDRST: Watchdog timer reset counter register (SFR A6h, reset value 00h)

Bit 7	Bit 6	Bit 5	Bit 4	Bit 3	Bit 2	Bit 1	Bit 0
WDRST[7:0]							

Table 55. WDRST register bit definition

Bit	Symbol	R/W	Definition
[7:0]	WDRST	W	This SFR is the upper byte of the 24-bit WDT up-counter. Writing this SFR sets the upper byte of the counter to the written value, and clears the lower two bytes of the counter to 0000h. Counting begins when WDKEY does not contain 55h.

Obsolete Product(s) - Obsolete Product(s)
Obsolete Product(s) - Obsolete Product(s)

20 Standard 8032 timer/counters

There are three 8032-style 16-bit Timer/Counter registers (Timer 0, Timer 1, Timer 2) that can be configured to operate as timers or event counters.

There are two additional 16-bit Timer/Counters in the Programmable Counter Array (PCA), see [Section 27.1: PCA block on page 181](#) for details.

20.1 Standard timer SFRs

Timer 0 and Timer 1 have very similar functions, and they share two SFRs for control:

- TCON ([Table 56 on page 97](#))
- TMOD ([Table 58 on page 99](#)).

Timer 0 has two SFRs that form the 16-bit counter, or that can hold reload values, or that can scale the clock depending on the timer/counter mode:

- TH0 is the high byte, address 8Ch
- TL0 is the low byte, address 8Ah

Timer 1 has two similar SFRs:

- TH1 is the high byte, address 8Dh
- TL1 is the low byte, address 8Bh

Timer 2 has one control SFR:

- T2CON ([Table 60 on page 101](#))

Timer 2 has two SFRs that form the 16-bit counter, and perform other functions:

- TH2 is the high byte, address CDh
- TL2 is the low byte, address CCh

Timer 2 has two SFRs for capture and reload:

- RCAP2H is the high byte, address CBh
- RCAP2L is the low byte, address CAh

20.2 Clock sources

When enabled in the “**Timer**” function, the registers THx and TLx are incremented every 1/12 of the oscillator frequency (f_{OSC}). This timer clock source is not effected by MCU clock dividers in the CCON0, stalls from PFQ/BC, or bus transfer cycles. Timers are always clocked at 1/12 of f_{OSC} .

When enabled in the “**Counter**” function, the registers THx and TLx are incremented in response to a 1-to-0 transition sampled at their corresponding external input pin: pin C0 for Timer 0; pin C1 for Timer 1; or pin T2 for Timer 2. In this function, the external clock input pin is sampled by the counter at a rate of 1/12 of f_{OSC} . When a logic '1' is determined in one sample, and a logic '0' in the next sample period, the count is incremented at the very next sample period (period1: sample=1, period2: sample=0, period3: increment count while continuing to sample). This means the maximum count rate is 1/24 of the f_{OSC} . There are no restrictions on the duty cycle of the external input signal, but to ensure that a given level is sampled at least once before it changes, it should be active for at least one full sample

period ($12 / f_{OSC}$, seconds). However, if MCU_CLK is divided by the SFR CCON0, then the sample period must be calculated based on the resultant, longer, MCU_CLK frequency. In this case, an external clock signal on pins C0, C1, or T2 should have a duration longer than one MCU machine cycle, t_{MACH_CYC} . [Section 19.5: Watchdog timer, WDT on page 92](#) explains how to estimate t_{MACH_CYC} .

Table 56. TCON: Timer control register (SFR 88h, reset value 00h)

Bit 7	Bit 6	Bit 5	Bit 4	Bit 3	Bit 2	Bit 1	Bit 0
TF1	TR1	TF0	TR0	IE1	IT1	IE0	IT0

Table 57. TCON register bit definition

Bit	Symbol	R/W	Definition
7	TF1	R	Timer 1 overflow interrupt flag. Set by hardware upon overflow. Automatically cleared by hardware after firmware services the interrupt for Timer 1.
6	TR1	R,W	Timer 1 run control. 1 = Timer/Counter 1 is on, 0 = Timer/Counter 1 is off.
5	TF0	R	Timer 0 overflow interrupt flag. Set by hardware upon overflow. Automatically cleared by hardware after firmware services the interrupt for Timer 0.
4	TR0	R,W	Timer 0 run control. 1 = Timer/Counter 0 is on, 0 = Timer/Counter 0 is off.
3	IE1	R	Interrupt flag for external interrupt pin, EXTINT1. Set by hardware when edge is detected on pin. Automatically cleared by hardware after firmware services EXTINT1 interrupt.
2	IT1	R,W	Trigger type for external interrupt pin EXTINT1. 1 = falling edge, 0 = low-level
1	IE0	R	Interrupt flag for external interrupt pin, EXTINT0. Set by hardware when edge is detected on pin. Automatically cleared by hardware after firmware services EXTINT0 interrupt.
0	IT0	R,W	Trigger type for external interrupt pin EXTINT0. 1 = falling edge, 0 = low-level

20.3 SFR, TCON

Timer 0 and Timer 1 share the SFR, TCON, that controls these timers and provides information about them. See [Table 56 on page 97](#).

Bits IE0 and IE1 are not related to Timer/Counter functions, but they are set by hardware when a signal is active on one of the two external interrupt pins, EXTINT0 and EXTINT1. For system information on all of these interrupts, see [Table 17 on page 63](#), Interrupt Summary.

Bits IT0 and IT1 are not related to Timer/Counter functions, but they control whether or not the two external interrupt input pins, EXTINT0 and EXTINT1 are edge or level triggered.

20.4 SFR, TMOD

Timer 0 and Timer 1 have four modes of operation controlled by the SFR named TMOD ([Table 58](#)).

20.5 Timer 0 and Timer 1 operating modes

The “Timer” or “Counter” function is selected by the C/\bar{T} control bits in TMOD. The four operating modes are selected by bit-pairs $M[1:0]$ in TMOD. Modes 0, 1, and 2 are the same for both Timer/Counters. Mode 3 is different.

20.5.1 Mode 0

Putting either Timer/Counter into Mode 0 makes it an 8-bit Counter with a divide-by-32 prescaler. [Figure 24](#) shows Mode 0 operation as it applies to Timer 1 (same applies to Timer 0).

In this mode, the Timer register is configured as a 13-bit register. As the count rolls over from all '1s' to all '0s,' it sets the Timer Interrupt flag TF1. The counted input is enabled to the Timer when $TR1 = 1$ and either $GATE = 0$ or $EXTINT1 = 1$. (Setting $GATE = 1$ allows the Timer to be controlled by external input pin, $EXTINT1$, to facilitate pulse width measurements). $TR1$ is a control bit in the SFR, TCON. $GATE$ is a bit in the SFR, TMOD.

The 13-bit register consists of all 8 bits of TH1 and the lower 5 bits of TL1. The upper 3 bits of TL1 are indeterminate and should be ignored. Setting the run flag, $TR1$, does not clear the registers.

Mode 0 operation is the same for the Timer 0 as for Timer 1. Substitute $TR0$, $TF0$, $C0$, $TL0$, $TH0$, and $EXTINT0$ for the corresponding Timer 1 signals in [Figure 24](#). There are two different $GATE$ Bits, one for Timer 1 and one for Timer 0.

20.5.2 Mode 1

Mode 1 is the same as Mode 0, except that the Timer register is being run with all 16 bits.

20.5.3 Mode 2

Mode 2 configures the Timer register as an 8-bit Counter (TL1) with automatic reload, as shown in [Figure 25 on page 100](#). Overflow from TL1 not only sets TF1, but also reloads TL1 with the contents of TH1, which is preset with firmware. The reload leaves TH1 unchanged. Mode 2 operation is the same for Timer/Counter 0.

20.5.4 Mode 3

Timer 1 in Mode 3 simply holds its count. The effect is the same as setting $TR1 = 0$.

Timer 0 in Mode 3 establishes TL0 and TH0 as two separate counters. The logic for Mode 3 on Timer 0 is shown in [Figure 26 on page 100](#). TL0 uses the Timer 0 control Bits: C/\bar{T} , $GATE$, $TR0$, and $TF0$, as well as the pin $EXTINT0$. TH0 is locked into a timer function (counting at a rate of $1/12 f_{OSC}$) and takes over the use of $TR1$ and $TF1$ from Timer 1. Thus, TH0 now controls the “Timer 1” interrupt flag.

Mode 3 is provided for applications requiring an extra 8-bit timer on the counter (see [Figure 26 on page 100](#)). With Timer 0 in Mode 3, a UPSD34xx device can look like it has three Timer/Counters (not including the PCA). When Timer 0 is in Mode 3, Timer 1 can be

turned on and off by switching it out of and into its own Mode 3, or can still be used by the serial port as a baud rate generator, or in fact, in any application not requiring an interrupt.

Table 58. TMOD: Timer mode register (SFR 89h, reset value 00h)

Bit 7	Bit 6	Bit 5	Bit 4	Bit 3	Bit 2	Bit 1	Bit 0
GATE	C/T	M[1:0]		GATE	C/T	M[1:0]	

Table 59. TMOD register bit definition

Bit	Symbol	R/W	Timer	Definition (T/C is abbreviation for Timer/Counter)
7	GATE	R,W	Timer 1	Gate control. When GATE = 1, T/C is enabled only while pin EXTINT1 is '1' and the flag TR1 is '1.' When GATE = 0, T/C is enabled whenever the flag TR1 is '1.'
6	C/T	R,W		Counter or Timer function select. When C/T = 0, function is timer, clocked by internal clock. C/T = 1, function is counter, clocked by signal sampled on external pin, C1.
[5:4]	M[1:0]	R,W		Mode Select. 00b = 13-bit T/C. 8 bits in TH1 with TL1 as 5-bit pre-scaler. 01b = 16-bit T/C. TH1 and TL1 are cascaded. No pre-scaler. 10b = 8-bit auto-reload T/C. TH1 holds a constant and loads into TL1 upon overflow. 11b = Timer Counter 1 is stopped.
3	GATE	R,W	Timer 0	Gate control. When GATE = 1, T/C is enabled only while pin EXTINT0 is '1' and the flag TR0 is '1.' When GATE = 0, T/C is enabled whenever the flag TR0 is '1.'
2	C/T	R,W		Counter or Timer function select. When C/T = 0, function is timer, clocked by internal clock. C/T = 1, function is counter, clocked by signal sampled on external pin, C0.
[1:0]	M[1:0]	R,W		Mode Select. 00b = 13-bit T/C. 8 bits in TH0 with TL0 as 5-bit pre-scaler. 01b = 16-bit T/C. TH0 and TL0 are cascaded. No pre-scaler. 10b = 8-bit auto-reload T/C. TH0 holds a constant and loads into TL0 upon overflow. 11b = TL0 is 8-bit T/C controlled by standard Timer 0 control bits. TH0 is a separate 8-bit timer that uses Timer 1 control bits.

Figure 24. Timer/counter mode 0: 13-bit counter

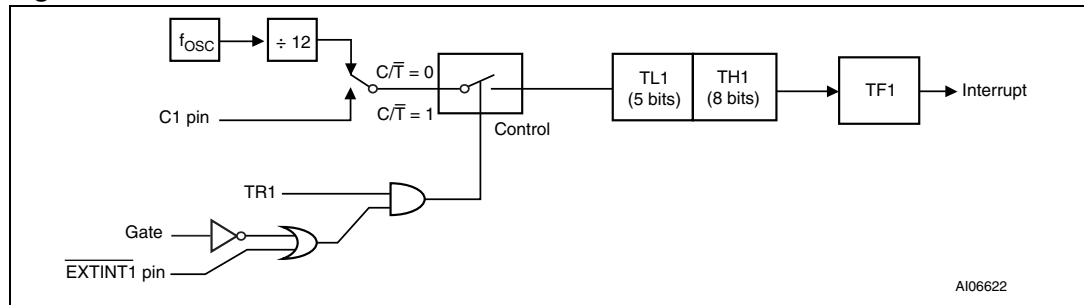

Figure 25. Timer/counter mode 2: 8-bit Auto-reload

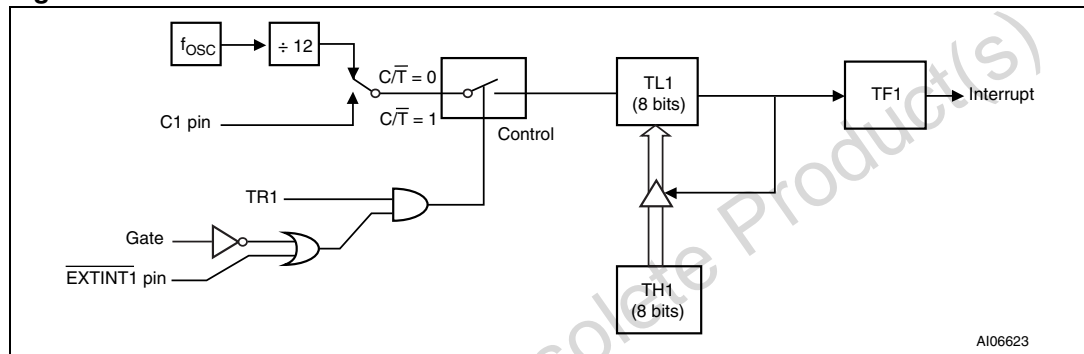
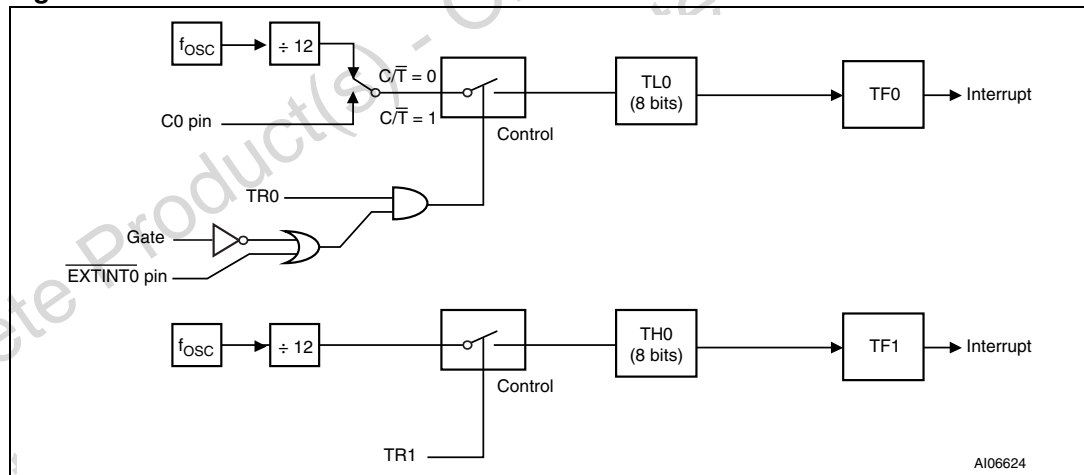

Figure 26. Timer/counter mode 3: two 8-bit counters



20.6 Timer 2

Timer 2 can operate as either an event timer or as an event counter. This is selected by the bit $C/\bar{T}2$ in the SFR named, T2CON ([Table 60 on page 101](#)). Timer 2 has three operating modes selected by bits in T2CON, according to [Table 62 on page 102](#). The three modes are:

- Capture mode
- Auto re-load mode
- Baud rate generator mode

20.6.1 Capture mode

In Capture mode there are two options which are selected by the bit EXEN2 in T2CON. *Figure 27 on page 105* illustrates Capture mode.

If EXEN2 = 0, then Timer 2 is a 16-bit timer if $C/\overline{T2} = 0$, or it is a 16-bit counter if $C/\overline{T2} = 1$, either of which sets the interrupt flag bit TF2 upon overflow.

If EXEN2 = 1, then Timer 2 still does the above, but with the added feature that a 1-to-0 transition at external input pin T2X causes the current value in the Timer 2 registers, TL2 and TH2, to be captured into registers RCAP2L and RCAP2H, respectively. In addition, the transition at T2X causes interrupt flag bit EXF2 in T2CON to be set. Either flag TF2 or EXF2 will generate an interrupt and the MCU must read both flags to determine the cause. Flags TF2 and EXF2 are not automatically cleared by hardware, so the firmware servicing the interrupt must clear the flag(s) upon exit of the interrupt service routine.

20.6.2 Auto-reload mode

In the Auto-reload mode, there are again two options, which are selected by the bit EXEN2 in T2CON. *Figure 28 on page 106* shows Auto-reload mode.

If EXEN2 = 0, then when Timer 2 counts up and rolls over from FFFFh it not only sets the interrupt flag TF2, but also causes the Timer 2 registers to be reloaded with the 16-bit value contained in registers RCAP2L and RCAP2H, which are preset with firmware.

If EXEN2 = 1, then Timer 2 still does the above, but with the added feature that a 1-to-0 transition at external input T2X will also trigger the 16-bit reload and set the interrupt flag EXF2. Again, firmware servicing the interrupt must read both TF2 and EXF2 to determine the cause, and clear the flag(s) upon exit.

Note: The UPSD34xx does not support selectable up/down counting in Auto-reload mode (this feature was an extension to the original 8032 architecture).

Table 60. T2CON: Timer 2 control register (SFR C8h, reset value 00h)

Bit 7	Bit 6	Bit 5	Bit 4	Bit 3	Bit 2	Bit 1	Bit 0
TF2	EXF2	RCLK	TCLK	EXEN2	TR2	$C/\overline{T2}$	CP/RL2

Table 61. T2CON register bit definition

Bit	Symbol	R/W	Definition
7	TF2	R,W	Timer 2 flag, causes interrupt if enabled. TF2 is set by hardware upon overflow. Must be cleared by firmware. TF2 will not be set when either RCLK or TCLK =1.
6	EXF2	R,W	Timer 2 flag, causes interrupt if enabled. EXF2 is set when a capture or reload is caused by a negative transition on T2X pin and EXEN2 = 1. EXF2 must be cleared by firmware.
5	RCLK ⁽¹⁾	R,W	UART0 Receive Clock control. When RCLK = 1, UART0 uses Timer 2 overflow pulses for its receive clock in Modes 1 and 3. RCLK=0, Timer 1 overflow is used for its receive clock

Table 61. T2CON register bit definition (continued)

Bit	Symbol	R/W	Definition
4	TCLK ⁽¹⁾	R,W	UART0 Transmit Clock control. When TCLK = 1, UART0 uses Timer 2 overflow pulses for its transmit clock in Modes 1 and 3. TCLK=0, Timer 1 overflow is used for transmit clock
3	EXEN2	R,W	Timer 2 External Enable. When EXEN2 = 1, capture or reload results when negative edge on pin T2X occurs. EXEN2 = 0 causes Timer 2 to ignore events at pin T2X.
2	TR2	R,W	Timer 2 run control. 1 = Timer/Counter 2 is on, 0 = Timer Counter 2 is off.
1	C/ $\overline{T2}$	R,W	Counter or Timer function select. When C/ $\overline{T2}$ = 0, function is timer, clocked by internal clock. When C/ $\overline{T2}$ = 1, function is counter, clocked by signal sampled on external pin, T2.
0	CP/ $\overline{RL2}$	R,W	Capture/Reload. When CP/ $\overline{RL2}$ = 1, capture occurs on negative transition at pin T2X if EXEN2 = 1. When CP/ $\overline{RL2}$ = 0, auto-reload occurs when Timer 2 overflows, or on negative transition at pin T2X when EXEN2=1. When RCLK = 1 or TCLK = 1, CP/ $\overline{RL2}$ is ignored, and Timer 2 is forced to auto-reload upon Timer 2 overflow

Note: 1 The RCLK1 and TCLK1 Bits in the SFR named PCON control UART1, and have the exact same function as RCLK and TCLK.

Table 62. Timer/counter 2 operating modes

Mode	Bits in T2CON SFR				Pin T2X (1)	Remarks	Input clock	
	RCLK or TCLK	CP/ $\overline{RL2}$	TR2	EXEN2			Timer, internal	Counter, external (Pin T2, P1.0)
16-bit Auto-reload	0	0	1	0	x	reload [RCAP2H, RCAP2L] to [TH2, TL2] upon overflow (upcounting)	f _{osc} /12	MAX f _{osc} /24
	0	0	1	1	↓	reload [RCAP2H, RCAP2L] to [TH2, TL2] at falling edge on pin T2X		
16-bit capture	0	1	1	0	x	16-bit timer/counter (upcounting)	f _{osc} /12	MAX f _{osc} /24
	0	1	1	1	↓	Capture [TH2, TL2] and store to [RCAP2H, RCAP2L] at falling edge on pin T2X		

Table 62. Timer/counter 2 operating modes (continued)

Mode	Bits in T2CON SFR				Pin T2X (1)	Remarks	Input clock	
	RCLK or TCLK	CP/RL2	TR2	EXEN2			Timer, internal	Counter, external (Pin T2, P1.0)
Baud rate generator	1	x	1	0	x	No overflow interrupt request (TF2)	f _{OSC} /2	-
	1	x	1	1	↓	Extra Interrupt on pin T2X, sets TF2		
Off	x	x	0	x	x	Timer 2 stops	-	-

1. ↓ = falling edge.

20.6.3 Baud rate generator mode

The RCLK and/or TCLK Bits in the SFR T2CON allow the transmit and receive baud rates on serial port UART0 to be derived from either Timer 1 or Timer 2. [Figure 29 on page 106](#) illustrates Baud rate generator mode.

When TCLK = 0, Timer 1 is used as UART0’s transmit baud generator. When TCLK = 1, Timer 2 will be the transmit baud generator. RCLK has the same effect for UART0’s receive baud rate. With these two bits, UART0 can have different receive and transmit baud rates - one generated by Timer 1, the other by Timer 2.

Note: Bits RCLK1 and TCLK1 in the SFR named PCON (see [Section Table 33.: PCON: power control register \(SFR 87h, reset value 00h\) on page 74](#)) have identical functions as RCLK and TCLK but they apply to UART1 instead. For simplicity in the following discussions about baud rate generation, no suffix will be used when referring to SFR registers and bits related to UART0 or UART1, since each UART interface has identical operation. Example, TCLK or TCLK1 will be referred to as just TCLK.

The Baud rate generator mode is similar to the Auto-reload mode, in that a roll over in TH2 causes the Timer 2 registers, TH2 and TL2, to be reloaded with the 16-bit value in registers RCAP2H and RCAP2L, which are preset with firmware.

The baud rates in UART Modes 1 and 3 are determined by Timer 2’s overflow rate as follows:

$$\text{UART Mode 1,3 Baud Rate} = \text{Timer 2 Overflow Rate} / 16$$

The timer can be configured for either “timer” or “counter” operation. In the most typical applications, it is configured for “timer” operation (C/T2 = 0). “Timer” operation is a little different for Timer 2 when it's being used as a baud rate generator. In this case, the baud rate is given by the formula:

$$\text{UART Mode 1,3 Baud Rate} = f_{\text{OSC}} / (32 \times [65536 - [\text{RCAP2H}, \text{RCAP2L}]])$$

where [RCAP2H, RCAP2L] is the content of the SFRs RCAP2H and RCAP2L taken as a 16-bit unsigned integer.

A roll-over in TH2 does not set TF2, and will not generate an interrupt. Therefore, the Timer Interrupt does not have to be disabled when Timer 2 is in the Baud rate generator mode.

If EXEN2 is set, a 1-to-0 transition on pin T2X will set the Timer 2 interrupt flag EXF2, but will not cause a reload from RCAP2H and RCAP2L to TH2 and TL2. Thus when Timer 2 is

in use as a baud rate generator, the pin T2X can be used as an extra external interrupt, if desired.

When Timer 2 is running (TR2 = 1) in a “timer” function in the Baud rate generator mode, firmware should not read or write TH2 or TL2. Under these conditions the results of a read or write may not be accurate. However, SFRs RCAP2H and RCAP2L may be read, but should not be written, because a write might overlap a reload and cause write and/or reload errors. Timer 2 should be turned off (clear TR2) before accessing Timer 2 or registers RCAP2H and RCAP2L, in this case.

Table 63 on page 104 shows commonly used baud rates and how they can be obtained from Timer 2, with T2CON = 34h.

Table 63. Commonly used baud rates generated from timer2 (T2CON = 34h)

f _{osc} MHz	Desired baud rate	Timer 2 SFRs		Resulting baud rate	Baud rate deviation
		RCAP2H (hex)	RCAP2L(hex)		
40.0	115200	FF	F5	113636	-1.36%
40.0	57600	FF	EA	56818	-1.36%
40.0	28800	FF	D5	29070	0.94%
40.0	19200	FF	BF	19231	0.16%
40.0	9600	FF	7E	9615	0.16%
36.864	115200	FF	F6	115200	0
36.864	57600	FF	EC	57600	0
36.864	28800	FF	D8	28800	0
36.864	19200	FF	C4	19200	0
36.864	9600	FF	88	9600	0
36.0	28800	FF	D9	28846	0.16%
36.0	19200	FF	C5	19067	-0.69%
36.0	9600	FF	8B	9615	0.16%
24.0	57600	FF	F3	57692	0.16%
24.0	28800	FF	E6	28846	0.16%
24.0	19200	FF	D9	19231	0.16%
24.0	9600	FF	B2	9615	0.16%
12.0	28800	FF	F3	28846	0.16%
12.0	9600	FF	D9	9615	0.16%
11.0592	115200	FF	FD	115200	0
11.0592	57600	FF	FA	57600	0
11.0592	28800	FF	F4	28800	0
11.0592	19200	FF	EE	19200	0
11.0592	9600	FF	DC	9600	0

Table 63. Commonly used baud rates generated from timer2 (T2CON = 34h) (continued)

f _{osc} MHz	Desired baud rate	Timer 2 SFRs		Resulting baud rate	Baud rate deviation
		RCAP2H (hex)	RCAP2L(hex)		
3.6864	115200	FF	FF	115200	0
3.6864	57600	FF	FE	57600	0
3.6864	28800	FF	FC	28800	0
3.6864	19200	FF	FA	19200	0
3.6864	9600	FF	F4	9600	0
1.8432	19200	FF	FD	19200	0
1.8432	9600	FF	FA	9600	0

Figure 27. Timer 2 in capture mode

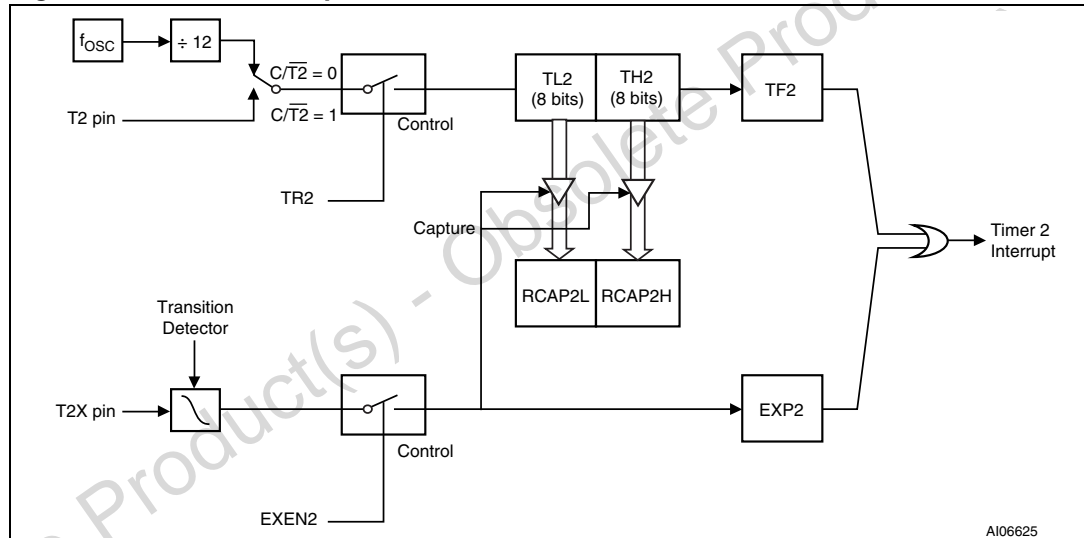

Figure 28. Timer 2 in auto-reload mode

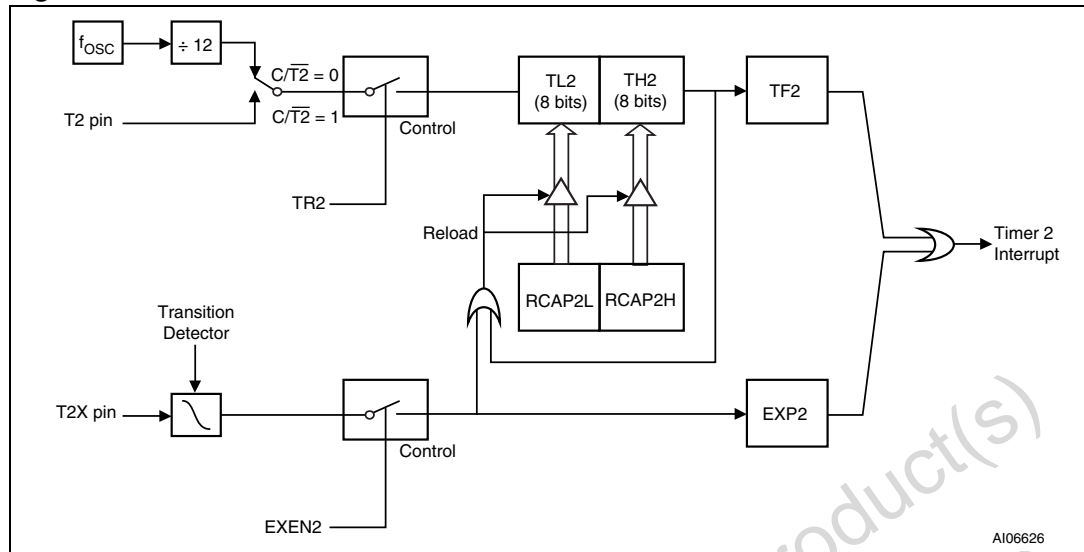
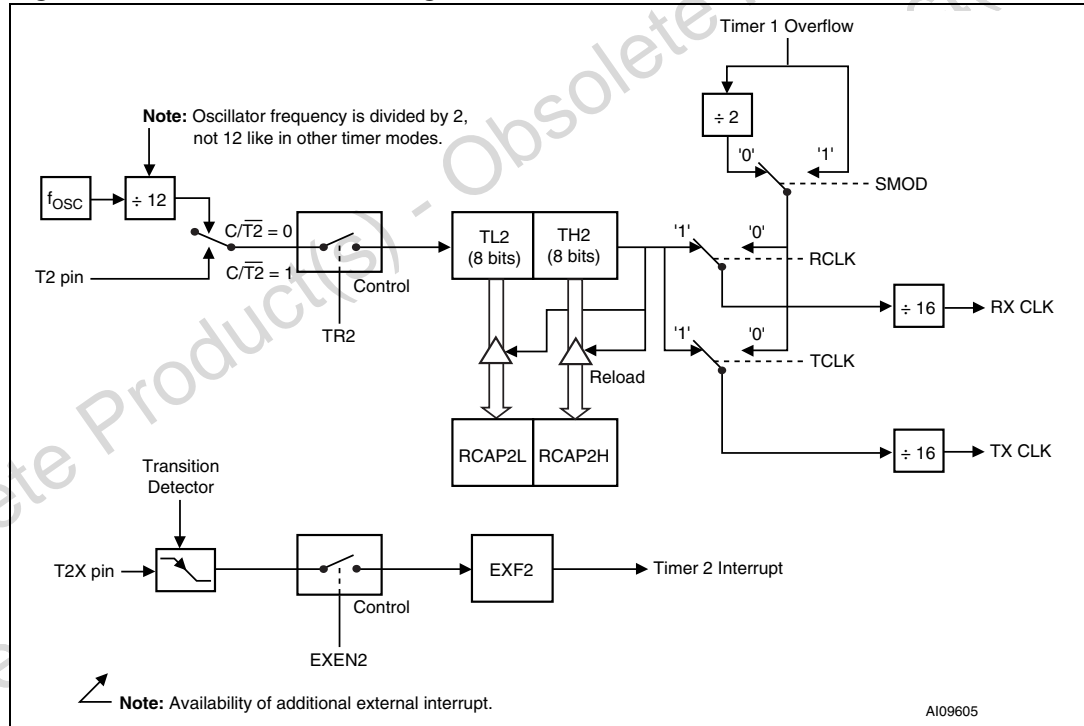

Figure 29. Timer 2 in baud rate generator mode



21 Serial UART interfaces

UPSD34xx devices provide two standard 8032 UART serial ports.

- The first port, UART0, is connected to pins RxD0 (P3.0) and TxD0 (P3.1)
- The second port, UART1 is connected to pins RxD1 (P1.2) and TxD1 (P1.3). UART1 can optionally be routed to pins P4.2 and P4.3 as described in [Section 17.1.4: Alternate functions on page 83](#).

The operation of the two serial ports are the same and are controlled by two SFRs:

- SCON0 ([Table 65 on page 109](#)) for UART0
- SCON1 ([Table 67 on page 109](#)) for UART1

Each UART has its own data buffer accessed through an SFR listed below:

- SBUF0 for UART0, address 99h
- SBUF1 for UART1, address D9h

When writing SBUF0 or SBUF1, the data automatically loads into the associated UART transmit data register. When reading this SFR, data comes from a different physical register, which is the receive register of the associated UART.

Note: For simplicity in the remaining UART discussions, the suffix “0” or “1” will be dropped when referring to SFR registers and bits related to UART0 or UART1, since each UART interface has identical operation. Example, SBUF0 and SBUF1 will be referred to as just SBUF.

Each UART serial port can be full-duplex, meaning it can transmit and receive simultaneously. Each UART is also receive-buffered, meaning it can commence reception of a second byte before a previously received byte has been read from the SBUF register. However, if the first byte still has not been read by the time reception of the second byte is complete, one of the bytes will be lost.

21.1 UART operation modes

Each UART can operate in one of four modes, one mode is synchronous, and the others are asynchronous as shown in [Table 64 on page 108](#).

21.1.1 Mode 0

Mode 0 provides asynchronous, half-duplex operation. Serial data is both transmitted, and received on the RxD pin. The TxD pin outputs a shift clock for both transmit and receive directions, thus the MCU must be the master. Eight bits are transmitted/received LSB first. The baud rate is fixed at $1/12$ of f_{OSC} .

21.1.2 Mode 1

Mode 1 provides standard asynchronous, full-duplex communication using a total of 10 bits per data byte. Data is transmitted through TxD and received through RxD with: a Start Bit (logic '0'), eight data bits (LSB first), and a Stop Bit (logic '1'). Upon receive, the eight data bits go into the SFR SBUF, and the Stop Bit goes into bit RB8 of the SFR SCON. The baud rate is variable and derived from overflows of Timer 1 or Timer 2.

21.1.3 Mode 2

Mode 2 provides asynchronous, full-duplex communication using a total of 11 bits per data byte. Data is transmitted through TxD and received through RxD with: a Start Bit (logic '0'); eight data bits (LSB first); a programmable 9th data bit; and a Stop Bit (logic '1'). Upon Transmit, the 9th data bit (from bit TB8 in SCON) can be assigned the value of '0' or '1.' Or, for example, the Parity Bit (P, in the PSW) could be moved into TB8. Upon receive, the 9th data bit goes into RB8 in SCON, while the Stop Bit is ignored. The baud rate is programmable to either 1/32 or 1/64 of f_{OSC} .

21.1.4 Mode 3

Mode 3 is the same as Mode 2 in all respects except the baud rate is variable like it is in Mode 1.

In all four modes, transmission is initiated by any instruction that uses SBUF as a destination register. Reception is initiated in Mode 0 by the condition RI = 0 and REN = 1. Reception is initiated in the other modes by the incoming Start Bit if REN = 1.

Table 64. UART operating modes

Mode	Synchronization	Bits of SFR, SCON		Baud clock	Data bits	Start/stop bits	See Figure
		SM0	SM1				
0	Synchronous	0	0	$f_{OSC}/12$	8	None	Figure 30 on page 113
1	Asynchronous	0	1	Timer 1 or Timer 2 Overflow	8	1 Start, 1 Stop	Figure 32 on page 115
2	Asynchronous	1	0	$f_{OSC}/32$ or $f_{OSC}/64$	9	1 Start, 1 Stop	Figure 34 on page 117
3	Asynchronous	1	1	Timer 1 or Timer 2 Overflow	9	1 Start, 1 Stop	Figure 36 on page 118

21.1.5 Multiprocessor communications

Modes 2 and 3 have a special provision for multiprocessor communications. In these modes, 9 data bits are received. The 9th one goes into bit RB8, then comes a stop bit. The port can be programmed such that when the stop bit is received, the UART interrupt will be activated only if bit RB8 = 1. This feature is enabled by setting bit SM2 in SCON. A way to use this feature in multi-processor systems is as follows: When the master processor wants to transmit a block of data to one of several slaves, it first sends out an address byte which identifies the target slave. An address byte differs from a data byte in that the 9th bit is 1 in an address byte and 0 in a data byte. With SM2 = 1, no slave will be interrupted by a data byte. An address byte, however, will interrupt all slaves, so that each slave can examine the received byte and see if it is being addressed. The addressed slave will clear its SM2 bit and prepare to receive the data bytes that will be coming. The slaves that were not being addressed leave their SM2 bits set and go on about their business, ignoring the coming data bytes.

SM2 has no effect in Mode 0, and in Mode 1, SM2 can be used to check the validity of the stop bit. In a Mode 1 reception, if SM2 = 1, the receive interrupt will not be activated unless a valid stop bit is received.

21.2 Serial port control registers

The SFR SCON0 controls UART0, and SCON1 controls UART1, shown in [Table 65](#) and [Table 67](#). These registers contain not only the mode selection bits, but also the 9th data bit for transmit and receive (bits TB8 and RB8), and the UART Interrupt flags, TI and RI.

Table 65. SCON0: serial port UART0 control register (SFR 98h, reset value 00h)

Bit 7	Bit 6	Bit 5	Bit 4	Bit 3	Bit 2	Bit 1	Bit 0
SM0	SM1	SM2	REN	TB8	RB8	TI	RI

Table 66. SCON0 register bit definition

Bit	Symbol	R/W	Definition
7	SM0	R,W	Serial Mode Select, See Table 64 on page 108 . Important, notice bit order of SM0 and SM1.
6	SM1	R,W	[SM0:SM1] = 00b, Mode 0 [SM0:SM1] = 01b, Mode 1 [SM0:SM1] = 10b, Mode 2 [SM0:SM1] = 11b, Mode 3
5	SM2	R,W	Serial Multiprocessor Communication Enable. Mode 0: SM2 has no effect but should remain 0. Mode 1: If SM2 = 0 then stop bit ignored. SM2 = 1 then RI active if stop bit = 1. Mode 2 and 3: Multiprocessor Comm Enable. If SM2=0, 9th bit is ignored. If SM2=1, RI active when 9th bit = 1.
4	REN	R,W	Receive Enable. If REN=0, UART reception disabled. If REN=1, reception is enabled
3	TB8	R,W	TB8 is assigned to the 9th transmission bit in Mode 2 and 3. Not used in Mode 0 and 1.
2	RB8	R,W	Mode 0: RB8 is not used. Mode 1: If SM2 = 0, the RB8 is the level of the received stop bit. Mode 2 and 3: RB8 is the 9th data bit that was received in Mode 2 and 3.
1	TI	R,W	Transmit Interrupt flag. Causes interrupt at end of 8th bit time when transmitting in Mode 0, or at beginning of stop bit transmission in other modes. Must clear flag with firmware.
0	RI	R,W	Receive Interrupt flag. Causes interrupt at end of 8th bit time when receiving in Mode 0, or halfway through stop bit reception in other modes (see SM2 for exception). Must clear this flag with firmware.

Table 67. SCON1: serial port UART1 control register (SFR D8h, reset value 00h)

Bit 7	Bit 6	Bit 5	Bit 4	Bit 3	Bit 2	Bit 1	Bit 0
SM0	SM1	SM2	REN	TB8	RB8	TI	RI

Table 68. SCON1 register bit definition

Bit	Symbol	R/W	Definition
7	SM0	R,W	Serial Mode Select, See Table 64 on page 108 . Important, notice bit order of SM0 and SM1. [SM0:SM1] = 00b , Mode 0 [SM0:SM1] = 01b , Mode 1 [SM0:SM1] = 10b , Mode 2 [SM0:SM1] = 11b , Mode 3
6	SM1	R,W	
5	SM2	R,W	Serial Multiprocessor Communication Enable. Mode 0: SM2 has no effect but should remain 0. Mode 1: If SM2 = 0 then stop bit ignored. SM2 = 1 then RI active if stop bit = 1. Mode 2 and 3: Multiprocessor Comm Enable. If SM2=0, 9th bit is ignored. If SM2=1, RI active when 9th bit = 1.
4	REN	R,W	Receive Enable. If REN=0, UART reception disabled. If REN=1, reception is enabled
3	TB8	R,W	TB8 is assigned to the 9th transmission bit in Mode 2 and 3. Not used in Mode 0 and 1.
2	RB8	R,W	Mode 0: RB8 is not used. Mode 1: If SM2 = 0, the RB8 is the level of the received stop bit. Mode 2 and 3: RB8 is the 9th data bit that was received in Mode 2 and 3.
1	TI	R,W	Transmit Interrupt flag. Causes interrupt at end of 8th bit time when transmitting in Mode 0, or at beginning of stop bit transmission in other modes. Must clear flag with firmware.
0	RI	R,W	Receive Interrupt flag. Causes interrupt at end of 8th bit time when receiving in Mode 0, or halfway through stop bit reception in other modes (see SM2 for exception). Must clear this flag with firmware.

21.3 UART baud rates

The baud rate in Mode 0 is fixed:

$$\text{Mode 0 Baud Rate} = f_{\text{OSC}} / 12$$

The baud rate in Mode 2 depends on the value of the bit SMOD in the SFR named PCON. If SMOD = 0 (default value), the baud rate is 1/64 the oscillator frequency, f_{OSC} . If SMOD = 1, the baud rate is 1/32 the oscillator frequency.

$$\text{Mode 2 Baud Rate} = (2^{\text{SMOD}} / 64) \times f_{\text{OSC}}$$

Baud rates in Modes 1 and 3 are determined by the Timer 1 or Timer 2 overflow rate.

21.3.1 Using timer 1 to generate baud rates

When Timer 1 is used as the baud rate generator (bits RCLK = 0, TCLK = 0), the baud rates in Modes 1 and 3 are determined by the Timer 1 overflow rate and the value of SMOD as follows:

$$\text{Mode 1,3 Baud Rate} = (2^{\text{SMOD}} / 32) \times (\text{Timer 1 overflow rate})$$

The Timer 1 Interrupt should be disabled in this application. The Timer itself can be configured for either “timer” or “counter” operation, and in any of its 3 running modes. In the most typical applications, it is configured for “timer” operation, in the Auto-reload Mode (high nibble of the SFR TMOD = 0010B). In that case the baud rate is given by the formula:

$$\text{Mode 1,3 Baud Rate} = (2^{\text{SMOD}} / 32) \times (f_{\text{OSC}} / (12 \times [256 - (\text{TH1})]))$$

Table 69 lists various commonly used baud rates and how they can be obtained from Timer 1.

21.3.2 Using timer/counter 2 to generate baud rates

See Section 20.6.3: Baud rate generator mode on page 103.

Table 69. Commonly used baud rates generated from timer 1

UART mode	f _{osc} MHz	Desired baud rate	Resultant baud rate	Baud rate deviation	SMOD bit in PCON	Timer 1		
						C/T Bit in TMOD	Timer mode in TMOD	TH1 reload value (hex)
Mode 0 Max	40.0	3.33MHz	3.33MHz	0	X	X	X	X
Mode 2 Max	40.0	1250 000	1250 000	0	1	X	X	X
Mode 2 Max	40.0	625 000	625 000	0	0	X	X	X
Modes 1 or 3	40.0	19200	18939	-1.36%	1	0	2	F5
Modes 1 or 3	40.0	9600	9470	-1.36%	1	0	2	EA
Modes 1 or 3	36.0	19200	18570	-2.34%	1	0	2	F6
Modes 1 or 3	33.333	57600	57870	0.47%	1	0	2	FD
Modes 1 or 3	33.333	28800	28934	0.47%	1	0	2	FA
Modes 1 or 3	33.333	19200	19290	0.47%	1	0	2	F7
Modes 1 or 3	33.333	9600	9645	0.47%	1	0	2	EE
Modes 1 or 3	24.0	9600	9615	0.16%	1	0	2	F3
Modes 1 or 3	12.0	4800	4808	0.16%	1	0	2	F3
Modes 1 or 3	11.0592	57600	57600	0	1	0	2	FF
Modes 1 or 3	11.0592	28800	28800	0	1	0	2	FE
Modes 1 or 3	11.0592	19200	19200	0	1	0	2	FD
Modes 1 or 3	11.0592	9600	9600	0	1	0	2	FA

Table 69. Commonly used baud rates generated from timer 1 (continued)

UART mode	f _{osc} MHz	Desired baud rate	Resultant baud rate	Baud rate deviation	SMOD bit in PCON	Timer 1		
						C/ \bar{T} Bit in TMOD	Timer mode in TMOD	TH1 reload value (hex)
Modes 1 or 3	3.6864	19200	19200	0	1	0	2	FF
Modes 1 or 3	3.6864	9600	9600	0	1	0	2	FE
Modes 1 or 3	1.8432	9600	9600	0	1	0	2	FF
Modes 1 or 3	1.8432	4800	4800	0	1	0	2	FE

21.4 More about UART mode 0

Refer to the block diagram in [Figure 30 on page 113](#), and timing diagram in [Figure 31 on page 113](#).

Transmission is initiated by any instruction which writes to the SFR named SBUF. At the end of a write operation to SBUF, a 1 is loaded into the 9th position of the transmit shift register and tells the TX Control unit to begin a transmission. Transmission begins on the following MCU machine cycle, when the "SEND" signal is active in [Figure 31](#).

SEND enables the output of the shift register to the alternate function on the port containing pin RxD, and also enables the SHIFT CLOCK signal to the alternate function on the port containing the pin, TxD. At the end of each SHIFT CLOCK in which SEND is active, the contents of the transmit shift register are shifted to the right one position.

As data bits shift out to the right, zeros come in from the left. When the MSB of the data byte is at the output position of the shift register, then the '1' that was initially loaded into the 9th position, is just to the left of the MSB, and all positions to the left of that contain zeros. This condition flags the TX Control unit to do one last shift, then deactivate SEND, and then set the interrupt flag TI. Both of these actions occur at S1P1.

Reception is initiated by the condition REN = 1 and RI = 0. At the end of the next MCU machine cycle, the RX Control unit writes the bits 11111110 to the receive shift register, and in the next clock phase activates RECEIVE. RECEIVE enables the SHIFT CLOCK signal to the alternate function on the port containing the pin, TxD. Each pulse of SHIFT CLOCK moves the contents of the receive shift register one position to the left while RECEIVE is active. The value that comes in from the right is the value that was sampled at the RxD pin. As data bits come in from the right, 1s shift out to the left. When the 0 that was initially loaded into the right-most position arrives at the left-most position in the shift register, it flags the RX Control unit to do one last shift, and then it loads SBUF. After this, RECEIVE is cleared, and the receive interrupt flag RI is set.

21.5 More about UART mode 1

Refer to the block diagram in [Figure 32 on page 115](#), and timing diagram in [Figure 33 on page 115](#).

Transmission is initiated by any instruction which writes to SBUF. At the end of a write operation to SBUF, a '1' is loaded into the 9th position of the transmit shift register and flags the TX Control unit that a transmission is requested. Transmission actually starts at the end of the MCU the machine cycle following the next rollover in the divide-by-16 counter. Thus, the bit times are synchronized to the divide-by-16 counter, not to the writing of SBUF. Transmission begins with activation of SEND which puts the start bit at pin TxD. One bit time later, DATA is activated, which enables the output bit of the transmit shift register to pin TxD. The first shift pulse occurs one bit time after that. As data bits shift out to the right, zeros are clocked in from the left. When the MSB of the data byte is at the output position of the shift register, then the 1 that was initially loaded into the 9th position is just to the left of the MSB, and all positions to the left of that contain zeros. This condition flags the TX Control unit to do one last shift and then deactivates SEND, and sets the interrupt flag, TI. This occurs at the 10th divide-by-16 rollover after a write to SBUF.

Reception is initiated by a detected 1-to-0 transition at the pin RxD. For this purpose RxD is sampled at a rate of 16 times whatever baud rate has been established. When a transition is detected, the divide-by-16 counter is immediately reset, and 1FFH is written into the input shift register. Resetting the divide-by-16 counter aligns its rollovers with the boundaries of the incoming bit times. The 16 states of the counter divide each bit time into 16ths. At the 7th, 8th, and 9th counter states of each bit time, the bit detector samples the value of RxD. The value accepted is the value that was seen in at least 2 of the 3 samples. This is done for noise rejection. If the value accepted during the first bit time is not '0,' the receive circuits are reset and the unit goes back to looking for another '1'-to-'0' transition. This is to provide rejection of false start bits. If the start bit proves valid, it is shifted into the input shift register, and reception of the rest of the frame will proceed. As data bits come in from the right, '1s' shift out to the left. When the start bit arrives at the left-most position in the shift register (which in mode 1 is a 9-bit register), it flags the RX Control unit to do one last shift, load SBUF and RB8, and set the receive interrupt flag RI. The signal to load SBUF and RB8, and to set RI, will be generated if, and only if, the following conditions are met at the time the final shift pulse is generated:

1. RI = 0, and
2. Either SM2 = 0, or the received stop bit = 1.

If either of these two conditions are not met, the received frame is irretrievably lost. If both conditions are met, the stop bit goes into RB8, the 8 data bits go into SBUF, and RI is activated. At this time, whether the above conditions are met or not, the unit goes back to looking for a '1'-to-'0' transition on pin RxD.

21.6 More about UART modes 2 and 3

For Mode 2, refer to the block diagram in [Figure 34 on page 117](#), and timing diagram in [Figure 35 on page 117](#). For Mode 3, refer to the block diagram in [Figure 36 on page 118](#), and timing diagram in [Figure 37 on page 118](#).

Keep in mind that the baud rate is programmable to either 1/32 or 1/64 of f_{OSC} in Mode 2, but Mode 3 uses a variable baud rate generated from Timer 1 or Timer 2 rollovers.

The receive portion is exactly the same as in Mode 1. The transmit portion differs from Mode 1 only in the 9th bit of the transmit shift register.

Transmission is initiated by any instruction which writes to SBUF. At the end of a write operation to SBUF, the TB8 Bit is loaded into the 9th position of the transmit shift register and flags the TX Control unit that a transmission is requested. Transmission actually starts at the end of the MCU the machine cycle following the next rollover in the divide-by-16 counter. Thus, the bit times are synchronized to the divide-by-16 counter, not to the writing of SBUF. Transmission begins with activation of SEND which puts the start bit at pin TxD. One bit time later, DATA is activated, which enables the output bit of the transmit shift register to pin TxD. The first shift pulse occurs one bit time after that. The first shift clocks a '1' (the stop bit) into the 9th bit position of the shift register. There-after, only zeros are clocked in. Thus, as data bits shift out to the right, zeros are clocked in from the left. When bit TB8 is at the output position of the shift register, then the stop bit is just to the left of TB8, and all positions to the left of that contain zeros. This condition flags the TX Control unit to do one last shift and then deactivate SEND, and set the interrupt flag, TI. This occurs at the 11th divide-by 16 rollover after writing to SBUF.

Reception is initiated by a detected 1-to-0 transition at pin RxD. For this purpose RxD is sampled at a rate of 16 times whatever baud rate has been established. When a transition is detected, the divide-by-16 counter is immediately reset, and 1FFH is written to the input shift register. At the 7th, 8th, and 9th counter states of each bit time, the bit detector samples the value of RxD. The value accepted is the value that was seen in at least 2 of the 3 samples. If the value accepted during the first bit time is not '0,' the receive circuits are reset and the unit goes back to looking for another '1'-to-'0' transition. If the start bit proves valid, it is shifted into the input shift register, and reception of the rest of the frame will proceed. As data bits come in from the right, '1s' shift out to the left. When the start bit arrives at the left-most position in the shift register (which in Modes 2 and 3 is a 9-bit register), it flags the RX Control unit to do one last shift, load SBUF and RB8, and set the interrupt flag RI. The signal to load SBUF and RB8, and to set RI, will be generated if, and only if, the following conditions are met at the time the final shift pulse is generated:

1. RI = 0, and
2. Either SM2 = 0, or the received 9th data bit = 1. If either of these conditions is not met, the received frame is irretrievably lost, and RI is not set. If both conditions are met, the received 9th data bit goes into RB8, and the first 8 data bits go into SBUF. One bit time later, whether the above conditions were met or not, the unit goes back to looking for a '1'-to-'0' transition on pin RxD.

Figure 34. UART mode 2, block diagram

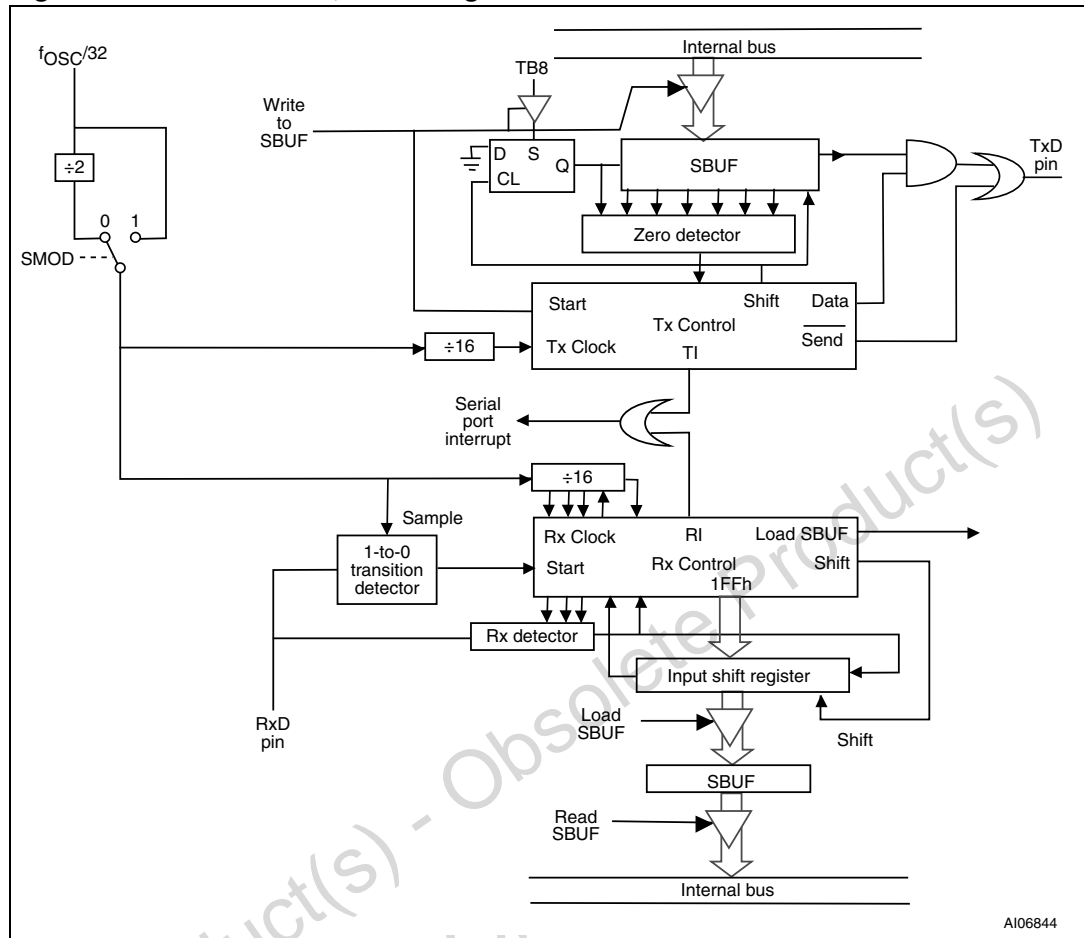

Figure 35. UART mode 2, timing diagram

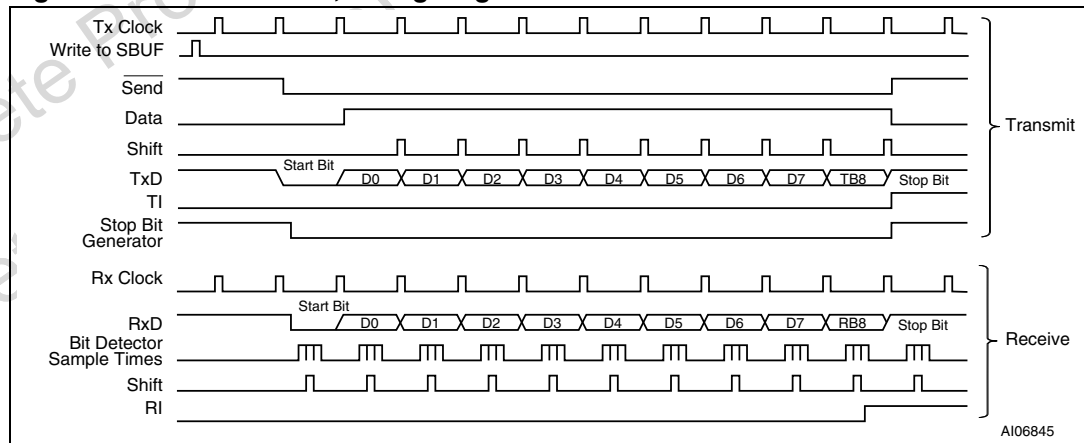
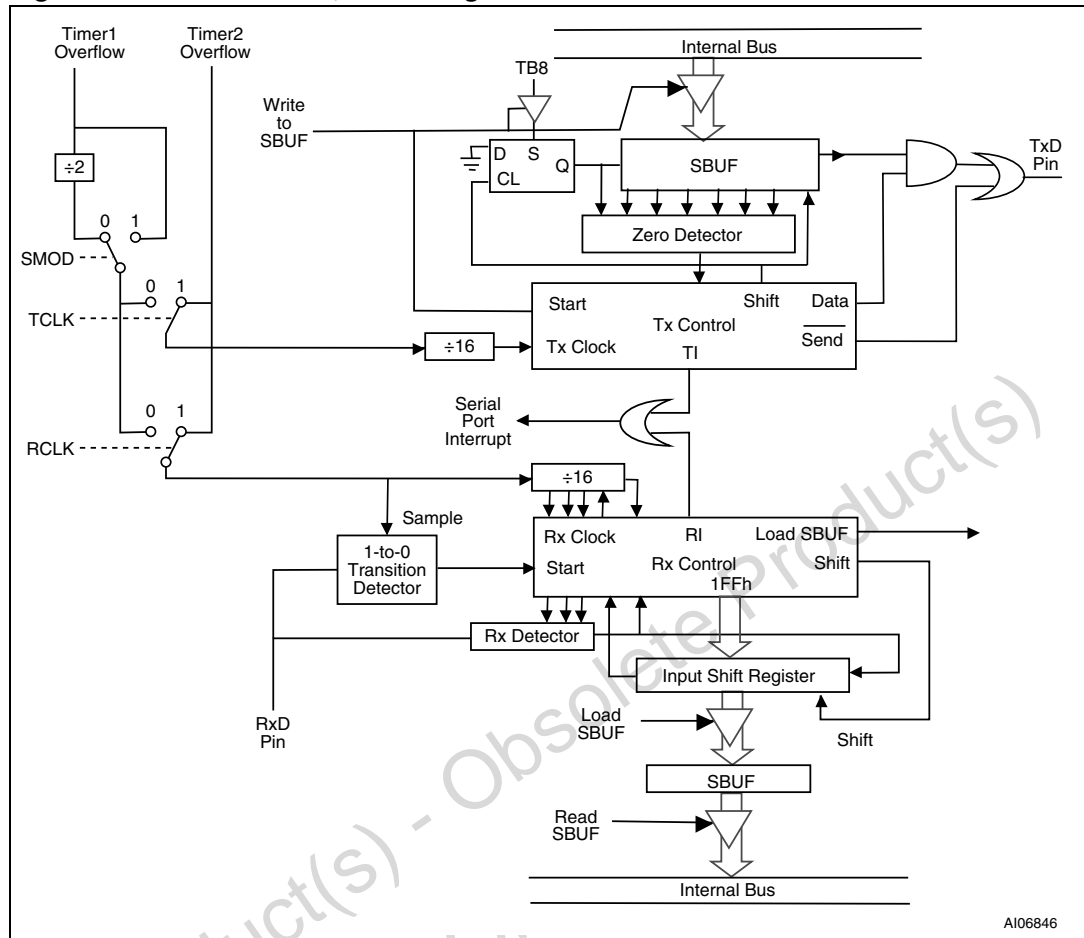
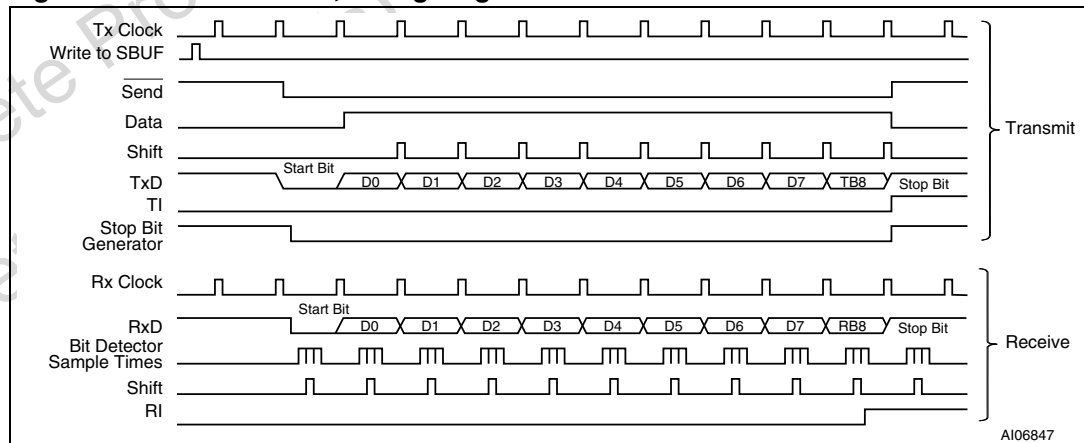

Figure 36. UART mode 3, block diagram



AI06846

Figure 37. UART mode 3, timing diagram



AI06847

22 IrDA interface

UPSD34xx devices provide an internal IrDA interface that will allow the connection of the UART1 serial interface directly to an external infrared transceiver device. The IrDA interface does this by automatically shortening the pulses transmitted on UART1's TxD1 pin, and stretching the incoming pulses received on the RxD1 pin. Reference Figures 38 and 39.

When the IrDA interface is enabled, the output signal from UART1's transmitter logic on pin TxD1 is compliant with the IrDA Physical Layer Link Specification v1.4 (www.irda.org) operating from 1.2k bps up to 115.2k bps. The pulses received on the RxD1 pin are stretched by the IrDA interface to be recognized by UART1's receiver logic, also adhering to the IrDA specification up to 115.2k bps.

Note: In Figure 39 a logic '0' in the serial data stream of a UART Frame corresponds to a logic high pulse in an IR Frame. A logic '1' in a UART Frame corresponds to no pulse in an IR Frame.

Figure 38. IrDA interface

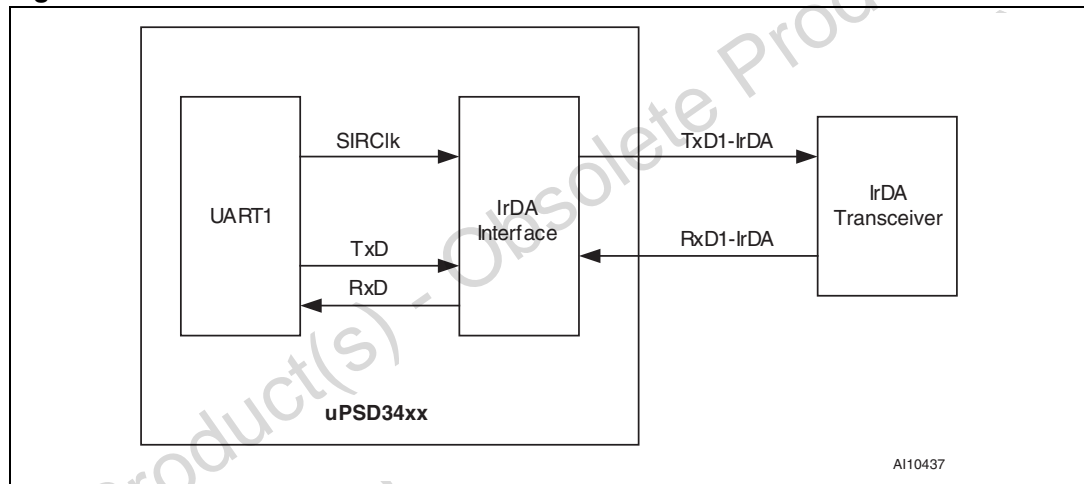
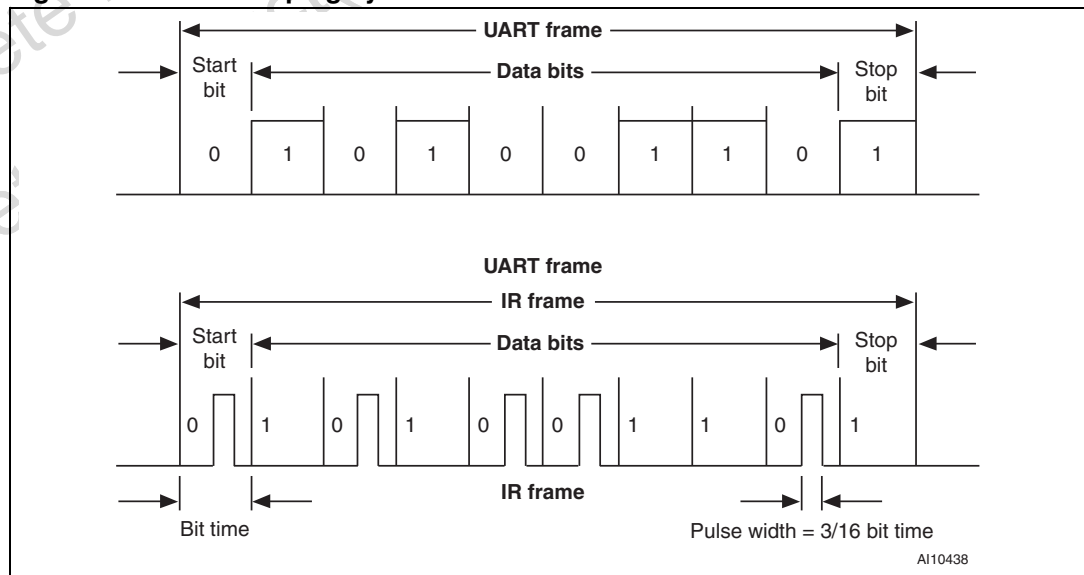

Figure 39. Pulse shaping by the IrDA interface



The UART1 serial channel can operate in one of four different modes as shown in [Table 64 on page 108](#) in [Section 21: Serial UART interfaces on page 107](#). However, when UART1 is used for IrDA communication, UART1 must operate in Mode 1 only, to be compatible with IrDA protocol up to 115.2k bps. The IrDA interface will support baud rates generated from Timer 1 or Timer 2, just like standard UART serial communication, but with one restriction. The transmit baud rate and receive baud rate must be the same (cannot be different rates as is allowed by standard UART communications).

The IrDA Interface is disabled after a reset and is enabled by setting the IRDAEN Bit in the SFR named IRDACON ([Table 70 on page 120](#)). When IrDA is disabled, the UART1's RxD and TxD signals will bypass the internal IrDA logic and instead they are routed directly to the pins RxD1 and TxD1 respectively. When IrDA is enabled, the IrDA pulse shaping logic is active and resides between UART1 and the pins RxD1 and TxD1 as shown in [Figure 38 on page 119](#).

22.1 Baud rate selection

The IrDA standard only supports 2.4, 9.6, 19.2, and 115.2kbps. [Table 73 on page 121](#) informs the IrDA Interface of the baud rate of UART#1 so that it can perform pulse modulation properly. It may not be necessary to implement the BR[3:0] bits in the IRDACON register if the IrDA Interface obtains the proper timing from UART#1.

Table 70. IRDACON register bit definition (SFR CEh, reset value 0Fh)

Bit 7	Bit 6	Bit 5	Bit 4	Bit 3	Bit 2	Bit 1	Bit 0
–	IRDAEN	PULSE	CDIV4	CDIV3	CDIV2	CDIV1	CDIV0

Table 71. IRDACON register bit definition

Bit	Symbol	R/W	Definition
7	–	–	Reserved
6	IRDAEN	RW	IrDA Enable 0 = IrDA Interface is disabled 1 = IrDA is enabled, UART1 outputs are disconnected from Port 1 (or Port 4)
5	PULSE	RW	IrDA Pulse Modulation Select 0 = 1.627µs 1 = 3/16 bit time pulses
4-0	CDIV[4:0]	RW	Specify Clock Divider (see Table 74 on page 122)

Table 72. Baud rate selection register (SFR xxh, reset value xxh)

Bit	Symbol	R/W	Definition
7:4	BR[3:0]	R,W	Specify Baud Rate (see Table 73)
3:2	PULSE	R,W	IrDA Pulse Modulation Select 0 = 3/16 bit time pulses (not recommended) 1 = 1.627µs
1:0	IRDAEN	R,W	0 = IrDA Interface is disabled 1 = IrDA is enabled, UART#1 outputs are disconnected from Port 1 (or Port 4)

Table 73. Baud rate of UART#1 for IrDA interface

BR3	BR2	BR1	BR0	Baud rate (kbps)
0	0	0	0	115.2
0	0	0	1	57.5
0	0	1	0	38.4
0	0	1	1	19.2
0	1	0	0	14.4
0	1	0	1	12.8
0	1	1	0	9.6
0	1	1	1	7.2
1	0	0	0	4.8
1	0	0	1	3.6
1	0	1	0	2.4
1	0	1	1	1.8
1	1	0	0	1.2

22.2 Pulse width selection

The IrDA interface has two ways to modulate the standard UART1 serial stream:

1. An IrDA data pulse will have a constant pulse width for any bit time, regardless of the selected baud rate.
2. An IrDA data pulse will have a pulse width that is proportional to the the bit time of the selected baud rate. In this case, an IrDA data pulse width is 3/16 of its bit time, as shown in [Figure 39 on page 119](#).

The PULSE bit in the SFR named IRDACON determines which method above will be used.

According to the IrDA physical layer specification, for all baud rates at 115.2k bps and below, the minimum data pulse width is 1.41µs. For a baud rate of 115.2k bps, the maximum pulse width 2.23µs. If a constant pulse width is to be used for all baud rates (PULSE bit = 0), the ideal general pulse width is 1.63µs, derived from the bit time of the fastest baud rate (8.68µs bit time for 115.2k bps rate), multiplied by the proportion, 3/16.

To produce this fixed data pulse width when the PULSE bit = 0, a prescaler is needed to generate an internal reference clock, SIRCk, shown in [Figure 38 on page 119](#). SIRCk is derived by dividing the oscillator clock frequency, f_{OSC} , using the five bits CDIV[4:0] in the SFR named IRDACON. A divisor must be chosen to produce a frequency for SIRCk that lies between 1.34 MHz and 2.13 MHz, but it is best to choose a divisor value that produces SIRCk frequency as close to 1.83MHz as possible, because SIRCk at 1.83MHz will produce an fixed IrDA data pulse width of 1.63µs. [Table 74](#) provides recommended values for CDIV[4:0] based on several different values of f_{OSC} .

For reference, SIRCk of 2.13MHz will generate a fixed IrDA data pulse width of 1.41 µs, and SIRCk of 1.34MHz will generate a fixed data pulse width of 2.23 µs.

**Table 74. Recommended CDIV[4:0] values to generate SIRCik
(default CDIV[4:0] = 0Fh, 15 decimal)**

f_{OSC} (MHz)	Value in CDIV[4:0]	Resulting f_{SIRCik} (MHz)
40.00	16h, 22 decimal	1.82
36.864, or 36.00	14h, 20 decimal	1.84, or 1.80
24.00	0Dh, 13 decimal	1.84
11.059, or 12.00	06h, 6 decimal	1.84, or 2.00
7.3728 ⁽¹⁾	04h, 4 decimal	1.84

1. When PULSE bit = 0 (fixed data pulse width), this is minimum recommended f_{OSC} because CDIV[4:0] must be 4 or greater.

23 I²C interface

UPSD34xx devices support one serial I²C interface. This is a two-wire communication channel, having a bidirectional data signal (SDA, pin P3.6) and a clock signal (SCL, pin P3.7) based on open-drain line drivers, requiring external pull-up resistors, R_P, each with a typical value of 4.7kΩ (see [Figure 40](#)).

23.1 I²C interface main features

Byte-wide data is transferred, MSB first, between a Master device and a Slave device on two wires. More than one bus Master is allowed, but only one Master may control the bus at any given time. Data is not lost when another Master requests the use of a busy bus because I²C supports collision detection and arbitration. The bus Master initiates all data movement and generates the clock that permits the transfer. Once a transfer is initiated by the Master, any device addressed is considered a Slave. Automatic clock synchronization allows I²C devices with different bit rates to communicate on the same physical bus. A single device can play the role of Master or Slave, or a single device can be a Slave only. Each Slave device on the bus has a unique address, and a general broadcast address is also available. A Master or Slave device has the ability to suspend data transfers if the device needs more time to transmit or receive data.

This I²C interface has the following features:

- Serial I/O Engine (SIOE): serial/parallel conversion; bus arbitration; clock generation and synchronization; and handshaking are all performed in hardware
- Interrupt or Polled operation
- Multi-master capability
- 7-bit Addressing
- Supports standard speed I²C (SCL up to 100kHz), fast mode I²C (101kHz to 400kHz), and high-speed mode I²C (401kHz to 833kHz)

Figure 40. Typical I²C bus configuration

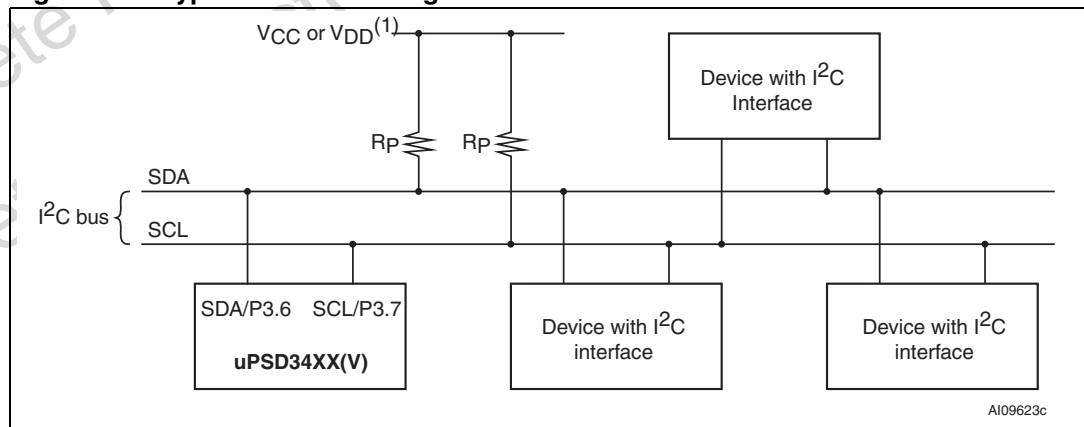

1. For 3.3 V system, connect R_P to 3.3 V V_{CC}. For 5.0 V system, connect R_P to 5.0 V V_{DD}.

23.2 Communication flow

I²C data flow control is based on the fact that all I²C compatible devices will drive the bus lines with open-drain (or open-collector) line drivers pulled up with external resistors, creating a wired-AND situation. This means that either bus line (SDA or SCL) will be at a logic '1' level only when no I²C device is actively driving the line to logic '0.' The logic for handshaking, arbitration, synchronization, and collision detection is implemented by each I²C device having:

1. The ability to hold a line low against the will of the other devices who are trying to assert the line high.
2. The ability of a device to detect that another device is driving the line low against its will.

Assert high means the driver releases the line and external pull-ups passively raise the signal to logic '1.' Holding low means the open-drain driver is actively pulling the signal to ground for a logic '0.'

For example, if a Slave device cannot transmit or receive a byte because it is distracted by an interrupt or it has to wait for some process to complete, it can hold the SCL clock line low. Even though the Master device is generating the SCL clock, the Master will sense that the Slave is holding the SCL line low against the will of the Master, indicating that the Master must wait until the Slave releases SCL before proceeding with the transfer.

Another example is when two Master devices try to put information on the bus simultaneously, the first one to release the SDA data line loses arbitration while the winner continues to hold SDA low.

Two types of data transfers are possible with I²C depending on the R/W bit, see [Figure 41 on page 125](#).

1. **Data transfer from master transmitter to slave receiver ($R/\bar{W} = 0$).** In this case, the Master generates a Start condition on the bus and it generates a clock signal on the SCL line. Then the Master transmits the first byte on the SDA line containing the 7-bit Slave address plus the R/W bit. The Slave who owns that address will respond with an acknowledge bit on SDA, and all other Slave devices will not respond. Next, the Master will transmit a data byte (or bytes) that the addressed Slave must receive. The Slave will return an acknowledge bit after each data byte it successfully receives. After the final byte is transmitted by the Master, the Master will generate a Stop condition on the bus, or it will generate a Re-Start condition and begin the next transfer. There is no limit to the number of bytes that can be transmitted during a transfer session.
2. **Data transfer from slave transmitter to master receiver ($R/\bar{W} = 1$).** In this case, the Master generates a Start condition on the bus and it generates a clock signal on the SCL line. Then the Master transmits the first byte on the SDA line containing the 7-bit Slave address plus the R/W bit. The Slave who owns that address will respond with an acknowledge bit on SDA, and all other Slave devices will not respond. Next, the addressed Slave will transmit a data byte (or bytes) to the Master. The Master will return an acknowledge bit after each data byte it successfully receives, unless it is the last byte the Master desires. If so, the Master will not acknowledge the last byte and from this, the Slave knows to stop transmitting data bytes to the Master. The Master will then generate a Stop condition on the bus, or it will generate a Re-Start condition and begin the next transfer. There is no limit to the number of bytes that can be transmitted during a transfer session.

A few things to know related to these transfers:

- Either the Master or Slave device can hold the SCL clock line low to indicate it needs more time to handle a byte transfer. An indefinite holding period is possible.
- A Start condition is generated by a Master and recognized by a Slave when SDA has a 1-to-0 transition while SCL is high (Figure 41 on page 125).
- A Stop condition is generated by a Master and recognized by a Slave when SDA has a 0-to-1 transition while SCL is high (Figure 41 on page 125).
- A Re-Start (repeated Start) condition generated by a Master can have the same function as a Stop condition when starting another data transfer immediately following the previous data transfer (Figure 41 on page 125).
- When transferring data, the logic level on the SDA line must remain stable while SCL is high, and SDA can change only while SCL is low. However, when not transferring data, SDA may change state while SCL is high, which creates the Start and Stop bus conditions.
- An Acknowledge bit is generated from a Master or a Slave by driving SDA low during the “ninth” bit time, just following each 8-bit byte that is transferred on the bus (Figure 41 on page 125). A Non-Acknowledge occurs when SDA is asserted high during the ninth bit time. All byte transfers on the I²C bus include a 9th bit time reserved for an Acknowledge (ACK) or Non-Acknowledge (NACK).
- An additional Master device that desires to control the bus should wait until the bus is not busy before generating a Start condition so that a possible Slave operation is not interrupted.
- If two Master devices both try to generate a Start condition simultaneously, the Master who loses arbitration will switch immediately to Slave mode so it can recognize its own Slave address should it appear on the bus.

Figure 41. Data transfer on an I²C bus

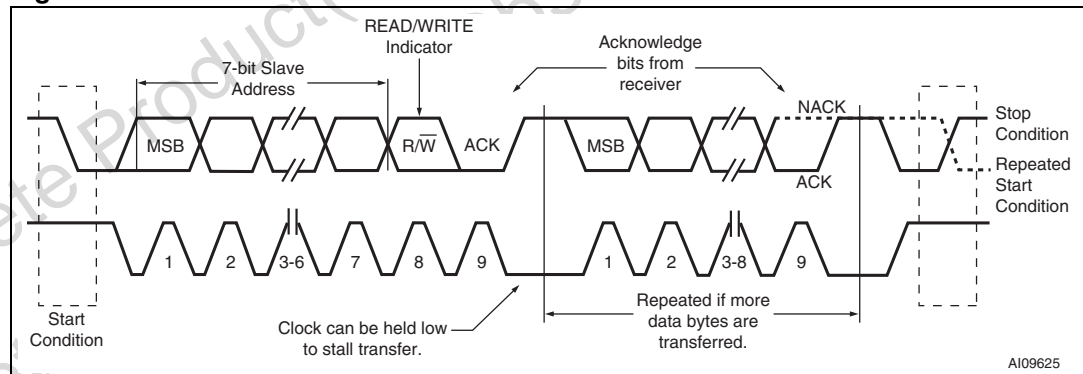

23.3 Operating modes

The I²C interface supports four operating modes:

- Master-transmitter
- Master-receiver
- Slave-transmitter
- Slave-receiver

The interface may operate as either a Master or a Slave within a given application, controlled by firmware writing to SFRs.

By default after a reset, the I²C interface is in Master Receiver mode, and the SDA/P3.6 and SCL/P3.7 pins default to GPIO input mode, high impedance, so there is no I²C bus interference. Before using the I²C interface, it must be initialized by firmware, and the pins must be configured. This is discussed in [Section 23.13: I2C operating sequences on page 135](#).

23.4 Bus arbitration

A Master device always samples the I²C bus to ensure a bus line is high whenever that Master is asserting a logic 1. If the line is low at that time, the Master recognizes another device is overriding its own transmission.

A Master may start a transfer only if the I²C bus is not busy. However, it is possible that two or more Masters may generate a Start condition simultaneously. In this case, arbitration takes place on the SDA line each time SCL is high. The Master that first senses that its bus sample does not correspond to what it is driving (SDA line is low while it is asserting a high) will immediately change from Master-Transmitter to Slave-Receiver mode. The arbitration process can carry on for many bit times if both Masters are addressing the same Slave device, and will continue into the data bits if both Masters are trying to be Master-Transmitter. It is also possible for arbitration to carry on into the acknowledge bits if both Masters are trying to be Master-Receiver. Because address and data information on the bus is determined by the winning Master, no information is lost during the arbitration process.

23.5 Clock synchronization

Clock synchronization is used to synchronize arbitrating Masters, or used as a handshake by a devices to slow down the data transfer.

23.5.1 Clock sync during arbitration

During bus arbitration between competing Masters, Master_X, with the longest low period on SCL, will force Master_Y to wait until Master_X finishes its low period before Master_Y proceeds to assert its high period on SCL. At this point, both Masters begin asserting their high period on SCL simultaneously, and the Master with the shortest high period will be the first to drive SCL for the next low period. In this scheme, the Master with the longest low SCL period paces low times, and the Master with the shortest high SCL period paces the high times, making synchronized arbitration possible.

23.5.2 Clock sync during handshaking

This allows receivers in different devices to handle various transfer rates, either at the byte-level, or bit-level.

At the byte-level, a device may pause the transfer between bytes by holding SCL low to have time to store the latest received byte or fetch the next byte to transmit.

At the bit-level, a Slave device may extend the low period of SCL by holding it low. Thus the speed of any Master device will adapt to the internal operation of the Slave.

23.6 General call address

A General Call (GC) occurs when a Master-Transmitter initiates a transfer containing a Slave address of 0000000b, and the R/W bit is logic 0. All Slave devices capable of responding to this broadcast message will acknowledge the GC simultaneously and then behave as a Slave-Receiver. The next byte transmitted by the Master will be accepted and acknowledged by all Slaves capable of handling the special data bytes. A Slave that cannot handle one of these data bytes must ignore it by not acknowledging it. The I²C specification lists the possible meanings of the special bytes that follow the first GC address byte, and the actions to be taken by the Slave device(s) upon receiving them. A common use of the GC by a Master is to dynamically assign device addresses to Slave devices on the bus capable of a programmable device address.

The UPSD34xx can generate a GC as a Master-Transmitter, and it can receive a GC as a Slave. When receiving a GC address (00h), an interrupt will be generated so firmware may respond to the special GC data bytes if desired.

23.7 Serial I/O engine (SIOE)

At the heart of the I²C interface is the hardware SIOE, shown in [Figure 42](#). The SIOE automatically handles low-level I²C bus protocol (data shifting, handshaking, arbitration, clock generation and synchronization) and it is controlled and monitored by five SFRs.

The five SFRs shown in [Figure 42](#) are:

- S1CON - Interface control ([Table 75 on page 129](#))
- S1STA - Interface status ([Table 78 on page 130](#))
- S1DAT - Data shift register ([Table 80 on page 132](#))
- S1ADR - Device address ([Table 82 on page 132](#))
- S1SETUP - Sampling rate ([Table 84 on page 133](#))

Figure 42. I²C interface SIOE block diagram

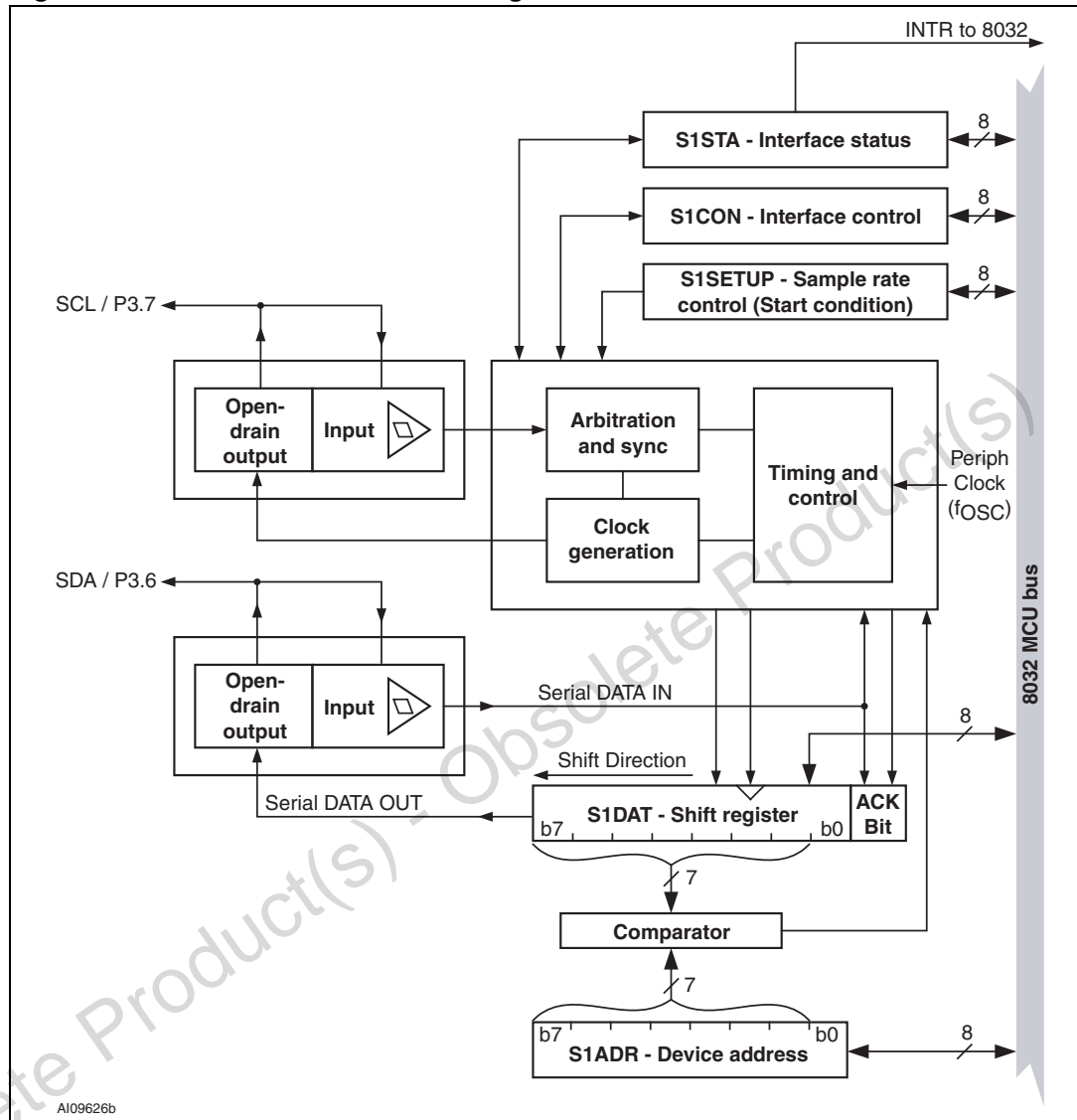

23.8 I²C interface control register (S1CON)

Table 75. Serial control register S1CON (SFR DCh, reset value 00h)

Bit 7	Bit 6	Bit 5	Bit 4	Bit 3	Bit 2	Bit 1	Bit 0
CR2	ENI1	STA	STO	ADDR	AA	CR[1:0]	

Table 76. S1CON register bit definition

Bit	Symbol	R/W	Function
7	CR2	R,W	This bit, along with bits CR1 and CR0, determine the SCL clock frequency (f_{SCL}) when SIOE is in Master mode. These bits create a clock divisor for f_{OSC} . See Table 77 .
6	ENI1	R,W	I ² C Interface Enable 0 = SIOE disabled, 1 = SIOE enabled. When disabled, both SDA and SCL signals are in high impedance state.
5	STA	R,W	START flag. When set, Master mode is entered and SIOE generates a Start condition only if the I ² C bus is not busy. When a Start condition is detected on the bus, the STA flag is cleared by hardware. When the STA bit is set during an interrupt service, the Start condition will be generated after the interrupt service.
4	STO	R,W	STOP flag When STO is set in Master mode, the SIOE generates a Stop condition. When a Stop condition is detected, the STO flag is cleared by hardware. When the STO bit is set during an interrupt service, the Stop condition will be generated after the interrupt service.
3	ADDR	R,W	This bit is set when an address byte received in Slave mode matches the device address programmed into the S1ADR register. The ADDR bit must be cleared with firmware.
2	AA	R,W	Assert Acknowledge enable If AA = 1, an acknowledge signal (low on SDA) is automatically returned during the acknowledge bit-time on the SCL line when any of the following three events occur: <ol style="list-style-type: none"> 1. SIOE in Slave mode receives an address that matches contents of S1ADR register 2. A data byte has been received while SIOE is in Master Receiver mode 3. A data byte has been received while SIOE is a selected Slave Receiver When AA = 0, no acknowledge is returned (high on SDA during acknowledge bit-time).
1, 0	CR1, CR0	R,W	These bits, along with bit CR2, determine the SCL clock frequency (f_{SCL}) when SIOE is in Master mode. These bits create a clock divisor for f_{OSC} . See Table 77 for values.

Table 77. Selection of the SCL frequency in Master mode based on f_{osc} examples

CR2	CR1	CR0	f _{osc} divided by:	Bitrate (kHz) @ f _{osc}			
				12 MHz f _{osc}	24 MHz f _{osc}	36 MHz f _{osc}	40 MHz f _{osc}
0	0	0	32	375	750	X ⁽¹⁾	X ⁽¹⁾
0	0	1	48	250	500	750	833
0	1	0	60	200	400	600	666
0	1	1	120	100	200	300	333
1	0	0	240	50	100	150	166
1	0	1	480	25	50	75	83
1	1	0	960	12.5	25	37.5	41
1	1	1	1920	6.25	12.5	18.75	20

1. These values are beyond the bit rate supported by UPSD34xx.

23.9 I²C interface status register (S1STA)

The S1STA register provides status regarding immediate activity and the current state of operation on the I²C bus. All bits in this register are read-only except bit 5, INTR, which is the interrupt flag.

23.9.1 Interrupt conditions

If the I²C interrupt is enabled (EI²C = 1 in SFR named IEA, and EA = 1 in SFR named IE), and the SIOE is initialized, then an interrupt is automatically generated when any one of the following five events occur:

- When the SIOE receives an address that matches the contents of the SFR, S1ADR. Requirements: SIOE is in Slave Mode, and bit AA = 1 in the SFR S1CON.
- When the SIOE receives General Call address. Requirements: SIOE is in Slave Mode, bit AA = 1 in the SFR S1CON
- When a complete data byte has been received or transmitted by the SIOE while in Master mode. The interrupt will occur even if the Master loses arbitration.
- When a complete data byte has been received or transmitted by the SIOE while in selected Slave mode.
- A Stop condition on the bus has been recognized by the SIOE while in selected Slave mode.

Selected Slave mode means the device address sent by the Master device at the beginning of the current data transfer matched the address stored in the S1ADR register.

If the I²C interrupt is not enabled, the MCU may poll the INTR flag in S1STA.

Table 78. S1STA: I²C interface status register (SFR DDh, reset value 00h)

Bit 7	Bit 6	Bit 5	Bit 4	Bit 3	Bit 2	Bit 1	Bit 0
GC	STOP	INTR	TX_MODE	BBUSY	BLOST	ACK_RESP	SLV

Table 79. S1STA register bit definition

Bit	Symbol	R/W	Function
7	GC	R	General Call flag GC = 1 if the General Call address of 00h was received when SIOE is in Slave mode, and GC is cleared by a Start or Stop condition on the bus. If the SIOE is in Master mode when GC = 1, the Bus Lost condition exists, and BLOST = 1.
6	STOP	R	STOP flag STOP = 1 while SIOE detects a Stop condition on the bus when in Master or Slave mode.
5	INTR	R,W	Interrupt flag INTR is set to 1 by any of the five I ² C interrupt conditions listed above. INTR must be cleared by firmware.
4	TX_MODE	R	Transmission Mode flag TX_MODE = 1 whenever the SIOE is in Master-Transmitter or Slave-Transmitter mode. TX_MODE = 0 when SIOE is in any receiver mode.
3	BBUSY	R	Bus Busy flag BBUSY = 1 when the I ² C bus is in use. BBUSY is set by the SIOE when a Start condition exists on the bus and BBUSY is cleared by a Stop condition.
2	BLOST	R	Bus Lost flag BLOST is set when the SIOE is in Master mode and it loses the arbitration process to another Master device on the bus.
1	ACK_RESP	R	Not Acknowledge Response flag While SIOE is in Transmitter mode: – After SIOE sends a byte, $\overline{ACK_RESP} = 1$ whenever the external I ² C device receives the byte, but that device does NOT assert an acknowledge signal (external device asserted a high on SDA during the acknowledge bit-time). – After SIOE sends a byte, $\overline{ACK_RESP} = 0$ whenever the external I ² C device receives the byte, and that device DOES assert an acknowledge signal (external device drove a low on SDA during the acknowledge bit-time) <i>Note: If SIOE is in Master-Transmitter mode, and $\overline{ACK_RESP} = 1$ due to a Slave-Transmitter not sending an Acknowledge, a Stop condition will not automatically be generated by the SIOE. The Stop condition must be generated with S1CON.STO = 1.</i>
0	SLV	R	Slave Mode flag SLV = 1 when the SIOE is in Slave mode. SLV = 0 when the SIOE is in Master mode (default).

23.10 I²C data shift register (S1DAT)

The S1ADR register ([Table 80](#)) holds a byte of serial data to be transmitted or it holds a serial byte that has just been received. The MCU may access S1DAT while the SIOE is not in the process of shifting a byte (the INTR flag indicates shifting is complete).

While transmitting, bytes are shifted out MSB first, and when receiving, bytes are shifted in MSB first, through the Acknowledge Bit register as shown in [Figure 42 on page 128](#).

23.10.1 Bus wait condition

After the SIOE finishes receiving a byte in Receive mode, or transmitting a byte in Transmit mode, the INTR flag (in S1STA) is set and automatically a wait condition is imposed on the I²C bus (SCL held low by SIOE). In Transmit mode, this wait condition is released as soon as the MCU writes any byte to S1DAT. In Receive mode, the wait condition is released as soon as the MCU reads the S1DAT register.

This method allows the user to handle transmit and receive operations within an interrupt service routine. The SIOE will automatically stall the I²C bus at the appropriate time, giving the MCU time to get the next byte ready to transmit or time to read the byte that was just received.

Table 80. S1DAT: I²C data shift register (SFR DEh, reset value 00h)

Bit 7	Bit 6	Bit 5	Bit 4	Bit 3	Bit 2	Bit 1	Bit 0
S1DAT[7:0]							

Table 81. S1DAT register bit definition

Bit	Symbol	R/W	Function
7:0	S1DAT[7:0]	R/W	Holds the data byte to be transmitted in Transmit mode, or it holds the data byte received in Receiver mode.

23.11 I²C address register (S1ADR)

The S1ADR register ([Table 82](#)) holds the 7-bit device address used when the SIOE is operating as a Slave. When the SIOE receives an address from a Master, it will compare this address to the contents of S1ADR, as shown in [Figure 42 on page 128](#).

If the 7 bits match, the INTR Interrupt flag (in S1STA) is set, and the ADDR Bit (in S1CON) is set. The SIOE cannot modify the contents S1ADR, and S1ADR is not used during Master mode.

Table 82. S1ADR: I²C address register (SFR DFh, reset value 00h)

Bit 7	Bit 6	Bit 5	Bit 4	Bit 3	Bit 2	Bit 1	Bit 0
SLA6	SLA5	SLA4	SLA3	SLA2	SLA1	SLA0	–

Table 83. S1ADR register bit definition

Bit	Symbol	R/W	Function
7:1	SLA[6:0]	R/W	Stores desired 7-bit device address, used when SIOE is in Slave mode.
0	–	–	Not used

23.12 I²C Start sample setting (S1SETUP)

The S1SETUP register ([Table 84](#)) determines how many times an I²C bus Start condition will be sampled before the SIOE validates the Start condition, giving the SIOE the ability to reject noise or illegal transmissions.

Because the minimum duration of an Start condition varies with I²C bus speed (f_{SCL}), and also because the UPSD34xx may be operated with a wide variety of frequencies (f_{OSC}), it is necessary to scale the number of samples per Start condition based on f_{OSC} and f_{SCL} .

In Slave mode, the SIOE recognizes the beginning of a Start condition when it detects a '1'-to-'0' transition on the SDA bus line while the SCL line is high (see [Figure 41 on page 125](#)). The SIOE must then validate the Start condition by sampling the bus lines to ensure SDA remains low and SCL remains high for a minimum amount of hold time, t_{HLDSTA} . Once validated, the SIOE begins receiving the address byte that follows the Start condition.

If the EN_SS Bit (in the S1SETUP register) is not set, then the SIOE will sample only once after detecting the '1'-to-'0' transition on SDA. This single sample is taken $1/f_{OSC}$ seconds after the initial 1-to-0 transition was detected. However, more samples should be taken to ensure there is a valid Start condition.

To take more samples, the SIOE should be initialized such that the EN_SS Bit is set, and a value is written to the SMPL_SET[6:0] field of the S1SETUP register to specify how many samples to take. The goal is to take a good number of samples during the minimum Start condition hold time, t_{HLDSTA} , but not so many samples that the bus will be sampled after t_{HLDSTA} expires.

[Table 86 on page 134](#) describes the relationship between the contents of S1SETUP and the resulting number of I²C bus samples that SIOE will take after detecting the 1-to-0 transition on SDA of a Start condition.

Important note: Keep in mind that the time between samples is always $1/f_{OSC}$.

The minimum Start condition hold time, t_{HLDSTA} , is different for the three common I²C speed categories per [Table 87 on page 134](#).

Table 84. S1SETUP: I²C Start condition sample setup register (SFR DBh, reset value 00h)

Bit 7	Bit 6	Bit 5	Bit 4	Bit 3	Bit 2	Bit 1	Bit 0
EN_SS	SMPL_SET[6:0]						

Table 85. S1SETUP register bit definition

Bit	Symbol	R/W	Function
7	EN_SS	R/W	Enable Sample Setup EN_SS = 1 will force the SIOE to sample ⁽¹⁾ a Start condition on the bus the number of times specified in SMPL_SET[6:0]. EN_SS = 0 means the SIOE will sample ⁽¹⁾ a Start condition only one time, regardless of the contents of SMPL_SET[6:0].
6:0	SMPL_SET [6:0]	–	Sample Setting Specifies the number of bus samples ⁽¹⁾ taken during a Start condition. See Table 86 for values.

1. Sampling SCL and SDA lines begins after '1'-to-'0' transition on SDA occurred while SCL is high. Time between samples is $1/f_{OSC}$.

Table 86. Number of I²C bus samples taken after 1-to-0 transition on SDA (Start condition)

Contents of S1SETUP		Resulting value for S1SETUP	Resulting number of samples taken after 1-to-0 on SDA line
SS_EN bit	SMPL_SET[6:0]		
0	XXXXXXXb	00h (default)	1
1	0000000b	80h	1
1	0000001b	81h	2
1	0000010b	82h	3
...
1	0001011b	8Bh	12
1	0010111b	97h	24
...
1	1111111b	FFh	128

Table 87. Start condition hold time

I ² C bus speed	Range of I ² C clock speed (f _{SCL})	Minimum Start condition hold time (t _{HLDSTA})
Standard	Up to 100 kHz	4000 ns
Fast	101 kHz to 400 kHz	600 ns
High	401 kHz to 833 kHz ⁽¹⁾	160 ns

1. 833KHz is maximum for UPSD34xx devices.

Table 88 provides recommended settings for S1SETUP based on various combinations of f_{OSC} and f_{SCL}. Note that the "Total Sample Period" times in **Table 87 on page 134** are typically slightly less than the minimum Start condition hold time, t_{HLDSTA} for a given I²C bus speed.

Important note: The SCL bit rate f_{SCL} must first be determined by bits CR[2:0] in the SFR S1CON before a value is chosen for SMPL_SET[6:0] in the SFR S1SETUP.

Table 88. S1SETUP examples for various I²C bus speeds and oscillator frequencies

I ² C bus speed, f _{SCL}	Parameter	Oscillator frequency, f _{osc}				
		6 MHz	12 MHz	24 MHz	33 MHz	40 MHz
Standard	Recommended S1SETUP value	93h	A7h	CFh	EEh	FFh
	Number of samples	20	40	80	111	128
	Time between samples	166.6 ns	83.3 ns	41.6 ns	30 ns	25 ns
	Total sampled period	3332 ns	3332 ns	3332 ns	3333 ns	3200 ns

Table 88. S1SETUP examples for various I²C bus speeds and oscillator frequencies (continued)

I ² C bus speed, f _{SCL}	Parameter	Oscillator frequency, f _{osc}				
		6 MHz	12 MHz	24 MHz	33 MHz	40 MHz
Fast	Recommended S1SETUP value	82h	85h	8Bh	90h	93h
	Number of samples	3	6	12	17	20
	Time between samples	166.6 ns	83.3 ns	41.6 ns	30 ns	25 ns
	Total sampled period	500 ns	500 ns	500 ns	510 ns	500 ns
High	Recommended S1SETUP value	(1)	80	82	83	84
	Number of samples	-	1	3	4	5
	Time between samples	-	83.3 ns	41.6 ns	30 ns	25 ns
	Total sampled period	-	83.3	125 ns	120 ns	125 ns

1. Not compatible with High Speed I²C.

23.13 I²C operating sequences

The following pseudo-code explains hardware control for these I²C functions on the UPSD34xx:

- Initialize the Interface
- Function as Master-Transmitter
- Function as Master-Receiver
- Function as Slave-Transmitter
- Function as Slave-Receiver
- Interrupt Service Routine

Full C code drivers for the UPSD34xx I²C interface, and other interfaces are available from the web at www.st.com\psm.

Initialization after a UPSD34xx reset

Ensure pins P3.6 and P3.7 are GPIO inputs

- SFR P3.7 = 1 and SFR P3.6 = 1

Configure pins P3.6 and P3.7 as I2C

- SFR P3SFS.6 = 1 and P3SFS.7 = 1

Set I2C clock prescaler to determine f_{SCL}

- SFR S1CON.CR[2:0] = desired SCL freq.

Set bus Start condition sampling

- SFR S1SETUP[7:0] = number of samples

Enable individual I2C interrupt and set priority

- SFR IEA.I2C = 1
- SFR IPA.I2C = 1 if high priority is desired

Set the Device address for Slave mode

- SFR S1ADR = XXh, desired address

Enable SIOE (as Slave) to return an ACK signal

- SFR S1CON.AA = 1

Master-Transmitter

Disable all interrupts

- SFR IE.EA = 0

Set pointer to global data xmit buffer, set count

- *xmit_buf = *pointer to data
- buf_length = number of bytes to xmit

Set global variables to indicate Master-Xmitter

- I2C_master = 1, I2C_xmitter = 1

Disable Master from returning an ACK

- SFR S1CON.AA = 0

Enable I2C SIOE

- SFR S1CON.INI1 = 1

Transmit Address and R/W bit = 0 to Slave

- Is bus not busy? (SFR S1STA.BBUSY = 0?)
- <If busy, then test until not busy>
- SFR S1DAT[7:0] = Load Slave Address & FEh
- SFR S1CON.STA = 1, send Start on bus
- <bus transmission begins>

Enable All Interrupts and go do something else

- SFR IE.EA = 1

Master-Receiver

Disable all interrupts

- SFR IE.EA = 0

Set pointer to global data recv buffer, set count

- *recv_buf = *pointer to data
- buf_length = number of bytes to recv

Set global variables to indicate Master-Xmitter

- I2C_master = 1, I2C_xmitter = 0

Disable Master from returning an ACK

- SFR S1CON.AA = 0

Enable I2C SIOE

- SFR S1CON.INI1 = 1

Transmit Address and R/W bit = 1 to Slave

- Is bus not busy? (SFR S1STA.BBUSY = 0?)
<If busy, then test until not busy>
- SFR S1DAT[7:0] = Load Slave Address # 01h
- SFR S1CON.STA = 1, send Start on bus
<bus transmission begins>

Enable All Interrupts and go do something else

- SFR IE.EA = 1

Slave-Transmitter

Disable all interrupts

- SFR IE.EA = 0

Set pointer to global data xmit buffer, set count

- *xmit_buf = *pointer to data
- buf_length = number of bytes to xmit

Set global variables to indicate Master-Xmitter

- I2C_master = 0, I2C_xmitter = 1

Enable SIOE

- SFR S1CON.INI1 = 1

Prepare to Xmit first data byte

- SFR S1DAT[7:0] = xmit_buf[0]

Enable All Interrupts and go do something else

- SFR IE.EA = 1

Slave-Receiver

Disable all interrupts

- SFR IE.EA = 0

Set pointer to global data recv buffer, set count

- *recv_buf = *pointer to data
- buf_length = number of bytes to recv

Set global variables to indicate Master-Xmitter

- I2C_master = 0, I2C_xmitter = 0

Enable SIOE

- SFR S1CON.INI1 = 1

Enable All Interrupts and go do something else

- SFR IE.EA = 1

23.13.1 Interrupt service routine (ISR)

A typical I²C interrupt service routine would handle an interrupt for any of the four combinations of Master/Slave and Transmitter/Receiver. In the example routines above, the firmware sets global variables, I2C_master and I2C_xmitter, before enabling interrupts. These flags tell the ISR which one of the four cases to process. Following is pseudo-code for high-level steps in the I²C ISR:

Begin I2C ISR <I2C interrupt just occurred>:

Clear I2C interrupt flag:

- S1STA.INTR = 0

Read status of SIOE, put in to variable, status

- status = S1STA

Read global variables that determine the mode

- mode <= (I2C_master, I2C_slave)

If mode is Master-Transmitter

Bus Arbitration lost? (status.BLOST=1?)

If Yes, Arbitration was lost:

- S1DAT = dummy, write to release bus
- Exit ISR, SIOE will switch to Slave Recv mode

If No, Arbitration was not lost, continue:

ACK recvd from Slave? (status.ACK_RESP=0?)

If No, an ACK was not received:

- S1CON.STO = 1, set Stop bus condition
- <Stop occurs after ISR exit>
- S1DAT = dummy, write to release bus
- Exit ISR

If Yes, ACK was received, then continue:

- S1DAT = xmit_buf[buffer_index], transmit byte

Was that the last byte of data to transmit?

If No, it was not the last byte, then:

- Exit ISR, transmit next byte on next interrupt

If Yes, it was the last byte, then:

- S1CON.STO = 1, set Stop bus condition

<Stop occurs after ISR exit>

- S1DAT = dummy, write to release bus

- Exit ISR

Else If mode is Master-Receiver:

Bus Arbitration lost? (status.BLOST=1?)

If Yes, Arbitration was lost:

- S1DAT = dummy, write to release bus
- Exit ISR, SIOE will switch to Slave Recv mode

If No, Arbitration was not lost, continue:

Is this Interrupt from sending an address to Slave, or is it from receiving a data byte from Slave?

If its from sending Slave address, goto A:

If its from receiving Slave data, goto B:

A: (Interrupt is from Master sending addr to Slave)

ACK recvd from Slave? (status.ACK_RESP=0?)

If No, an ACK was not received:

- S1CON.STO = 1, set Stop condition

<Stop occurs after ISR exit>

- dummy = S1DAT, read to release bus
- Exit ISR

If Yes, ACK was received, then continue:

- dummy = S1DAT, read to release bus

Does Master want to receive just one data byte?

If Yes, do not allow Master to ACK on next interrupt:

<S1CON.AA is already 0>

- Exit ISR, now ready to recv one byte from Slv

If No, Master can ACK next byte from Slv

- S1CON.AA = 1, allow Master to send ACK

- Exit ISR, now ready to recv data from Slave

B: (Interrupt is from Master recving data from Slv)

- recv_buf[buffer_index] = S1DAT, read byte

Is this the last data byte to receive from Slave?

If Yes, tell Slave to stop transmitting:

- S1CON.STO = 1, set Stop bus condition

<Stop occurs after ISR exit>

- Exit ISR, finished receiving data from Slave

If No, continue:

Is this the next to last byte to receive from Slave?

If this is the next to last byte, do not allow Master to ACK on next interrupt.

- S1CON.AA = 0, don't let Master return ACK
- Exit ISR, now ready to recv last byte from Slv

If this is not next to last byte, let Master send ACK to Slave

<S1CON.AA is already 1>

- Exit ISR, ready to recv more bytes from Slave

Else If mode is Slave-Transmitter:

Is this Intr from SIOE detecting a Stop on bus?

If Yes, a Stop was detected:

- S1DAT = dummy, write to release bus
- Exit ISR, Master needs no more data bytes

If No, a Stop was not detected, continue:

ACK recvd from Master? (status.ACK_RESP=0?)

If No, an ACK was not received:

- S1DAT = dummy, write to release bus
- Exit ISR, Master needs no more data bytes

If Yes, ACK was received, then continue:

- S1DAT = xmit_buf[buffer_index], transmit byte
- Exit ISR, transmit next byte on next interrupt

Else If mode is Slave-Receiver:

Is this Intr from SIOE detecting a Stop on bus?

If Yes, a Stop was detected:

- recv_buf[buffer_index] = S1DAT, get last byte
- Exit ISR, Master has sent last byte

If No, a Stop was not detected, continue:

Determine if this Interrupt is from receiving an address or a data byte from a Master.

Is (S1CON.ADDR = 1 and S1CON.AA =1)?

If No, intr is from receiving data, goto C:

If Yes, intr is from an address, continue:

- slave_is_adressed = 1, local variable set true
<indicates Master selected this slave>
- S1CON.ADDR = 0, clear address match flag

Determine if R/W bit indicates transmit or receive.

Does status.TX_MODE = 1?

 If Yes, Master wants transmit mode

- Exit ISR, indicate Master wants Slv-Xmit mode

 If No, Master wants Slave-Recv mode

- dummy = S1DAT, read to release bus
- Exit ISR, ready to recv data on next interrupt

C: (Interrupt is from Slv receiving data from Mastr)

- recv_buf[buffer_index] = S1DAT, read byte
- Exit ISR, recv next byte on next interrupt

Obsolete Product(s) - Obsolete Product(s)
Obsolete Product(s) - Obsolete Product(s)

24 SPI (synchronous peripheral interface)

UPSD34xx devices support one serial SPI interface in Master Mode only. This is a three- or four-wire synchronous communication channel, capable of full-duplex operation on 8-bit serial data transfers. The four SPI bus signals are:

- SPIRxD
Pin P1.5 or P4.5 receives data from the Slave SPI device to the UPSD34xx
- SPITxD
Pin P1.6 or P4.6 transmits data from the UPSD34xx to the Slave SPI device
- SPICLK
Pin P1.4 or P4.4 clock is generated from the UPSD34xx to the SPI Slave device
- $\overline{\text{SPISEL}}$
Pin P1.7 or P4.7 selects the signal from the UPSD34xx to an individual Slave SPI device

This SPI interface supports single-Master/multiple-Slave connections. Multiple-Master connections are not directly supported by the UPSD34xx (no internal logic for collision detection).

If more than one Slave device is required, the $\overline{\text{SPISEL}}$ signal may be generated from UPSD34xx GPIO outputs (one for each Slave) or from the PLD outputs of the PSD module. [Figure 43](#) illustrates three examples of SPI device connections using the UPSD34xx:

- Single-Master/Single-Slave with $\overline{\text{SPISEL}}$
- Single-Master/Single-Slave without $\overline{\text{SPISEL}}$
- Single-Master/Multiple-Slave without $\overline{\text{SPISEL}}$

Figure 43. SPI device connection examples

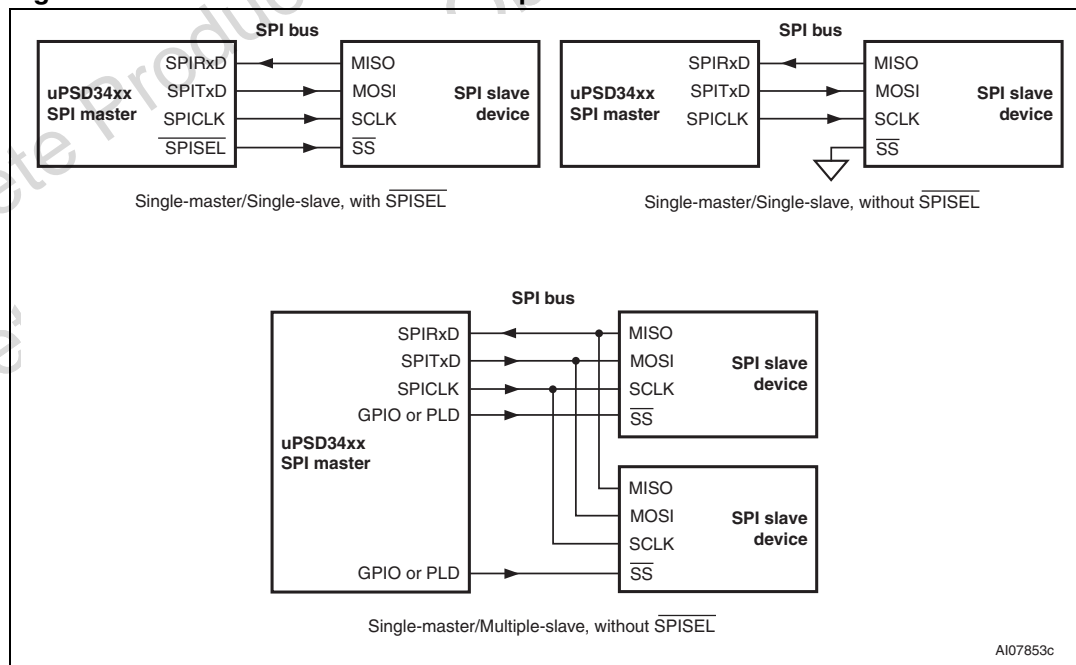

AI07853c

24.1 SPI bus features and communication flow

The SPICLK signal is a gated clock generated from the UPSD34xx (Master) and regulates the flow of data bits. The Master may transmit at a variety of baud rates, and the SPICLK signal will clock one period for each bit of transmitted data. Data is shifted on one edge of SPICLK and sampled on the opposite edge.

The SPITxD signal is generated by the Master and received by the Slave device. The SPIRxD signal is generated by the Slave device and received by the Master. There may be no more than one Slave device transmitting data on SPIRxD at any given time in a multi-Slave configuration. Slave selection is accomplished when a Slave's "Slave Select" (SS) input is permanently grounded or asserted active-low by a Master device. Slave devices that are not selected do not interfere with SPI activities. Slave devices ignore SPICLK and keep their MISO output pins in high-impedance state when not selected.

The SPI specification allows a selection of clock polarity and clock phase with respect to data. The UPSD34xx supports the choice of clock polarity, but it does not support the choice of clock phase (phase is fixed at what is typically known as CPHA = 1). See [Figure 45](#) and [Figure 46 on page 145](#) for SPI data and clock relationships.

Referring to these figures ([45](#) and [46](#)), when the phase mode is defined as such (fixed at CPHA = 1), in a new SPI data frame, the Master device begins driving the first data bit on SPITxD at the very first edge of the first clock period of SPICLK.

The Slave device will use this first clock edge as a transmission start indicator, and therefore the Slave's Slave Select input signal may remain grounded in a single-Master/single-Slave configuration (which means the user does not have to use the SPISEL signal from UPSD34xx in this case).

The SPI specification does not specify high-level protocol for data exchange, only low-level bit-serial transfers are defined.

24.2 Full-duplex operation

When an SPI transfer occurs, 8 bits of data are shifted out on one pin while a different 8 bits of data are simultaneously shifted in on a second pin. Another way to view this transfer is that an 8-bit shift register in the Master and another 8-bit shift register in the Slave are connected as a circular 16-bit shift register. When a transfer occurs, this distributed shift register is shifted 8 bit positions; thus, the data in the Master and Slave devices are effectively exchanged (see [Figure 44](#)).

24.3 Bus-level activity

[Figure 45](#) details an SPI receive operation (with respect to bus Master) and [Figure 46](#) details an SPI transmit operation. Also shown are internal flags available to firmware to manage data flow. These flags are accessed through a number of SFRs.

Note: The UPSD34xx SPI interface SFRs allow the choice of transmitting the most significant bit (MSB) of a byte first, or the least significant bit (LSB) first. The same bit-order applies to data reception. [Figures 45 and 46](#) illustrate shifting the LSB first.

Figure 44. SPI full-duplex data exchange

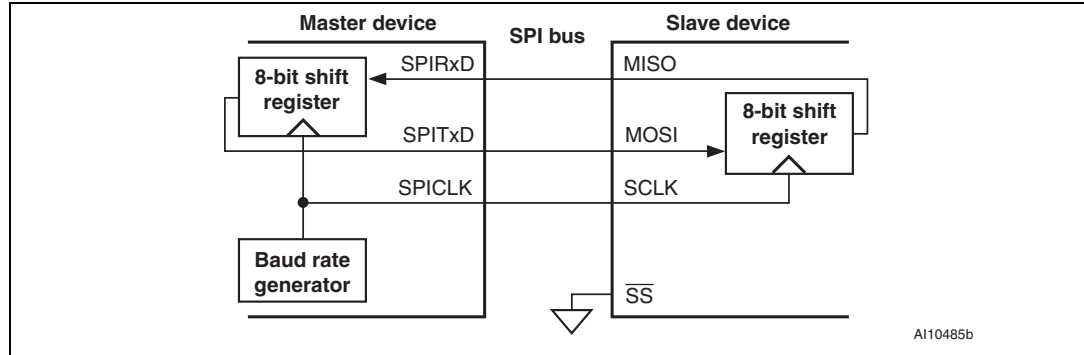

Figure 45. SPI receive operation example

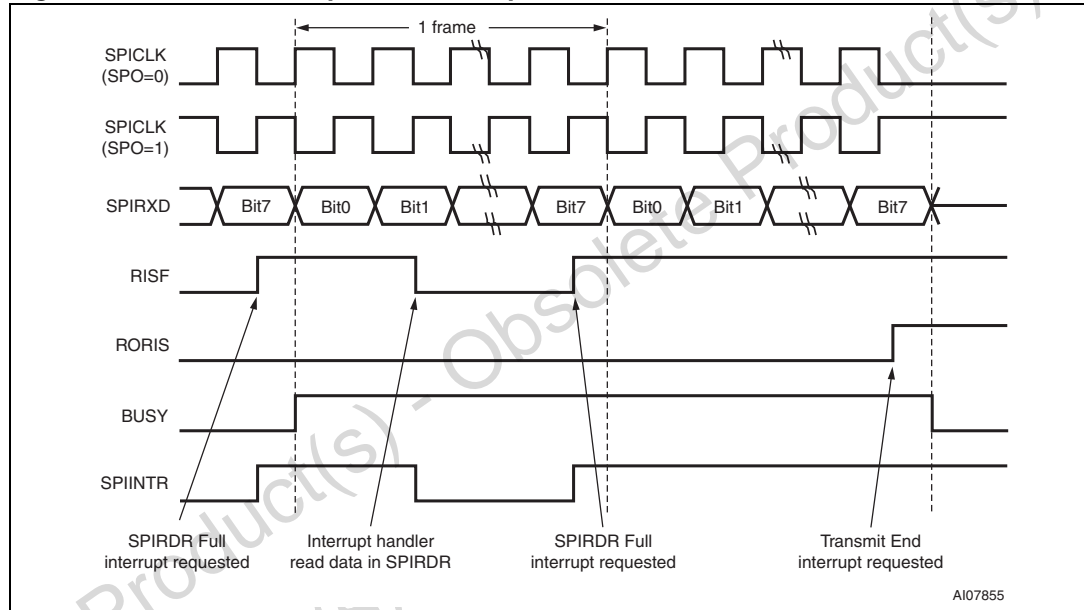
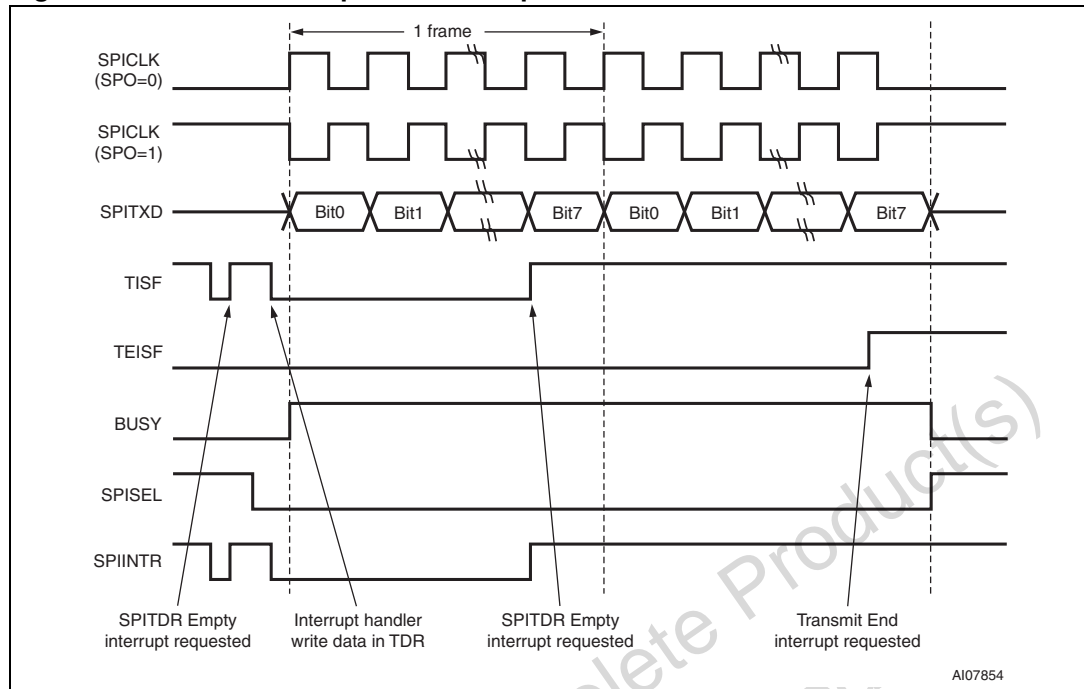

Figure 46. SPI transmit operation example



24.4 SPI SFR registers

Six SFR registers control the SPI interface:

- SPICON0 (Table 89) for interface control
- SPICON1 (Table 91) for interrupt control
- SPITDR (SFR D4h, Write only) holds byte to transmit
- SPIRDR (SFR D5h, Read only) holds byte received
- SPICLKD (Table 93) for clock divider
- SPISTAT (Table 95 on page 149) holds interface status

The SPI interface functional block diagram (Figure 47) shows these six SFRs. Both the transmit and receive data paths are double-buffered, meaning that continuous transmitting or receiving (back-to-back transfer) is possible by reading from SPIRDR or writing data to SPITDR while shifting is taking place. There are a number of flags in the SPISTAT register that indicate when it is full or empty to assist the 8032 MCU in data flow management. When enabled, these status flags will cause an interrupt to the MCU.

Figure 47. SPI interface, master mode only

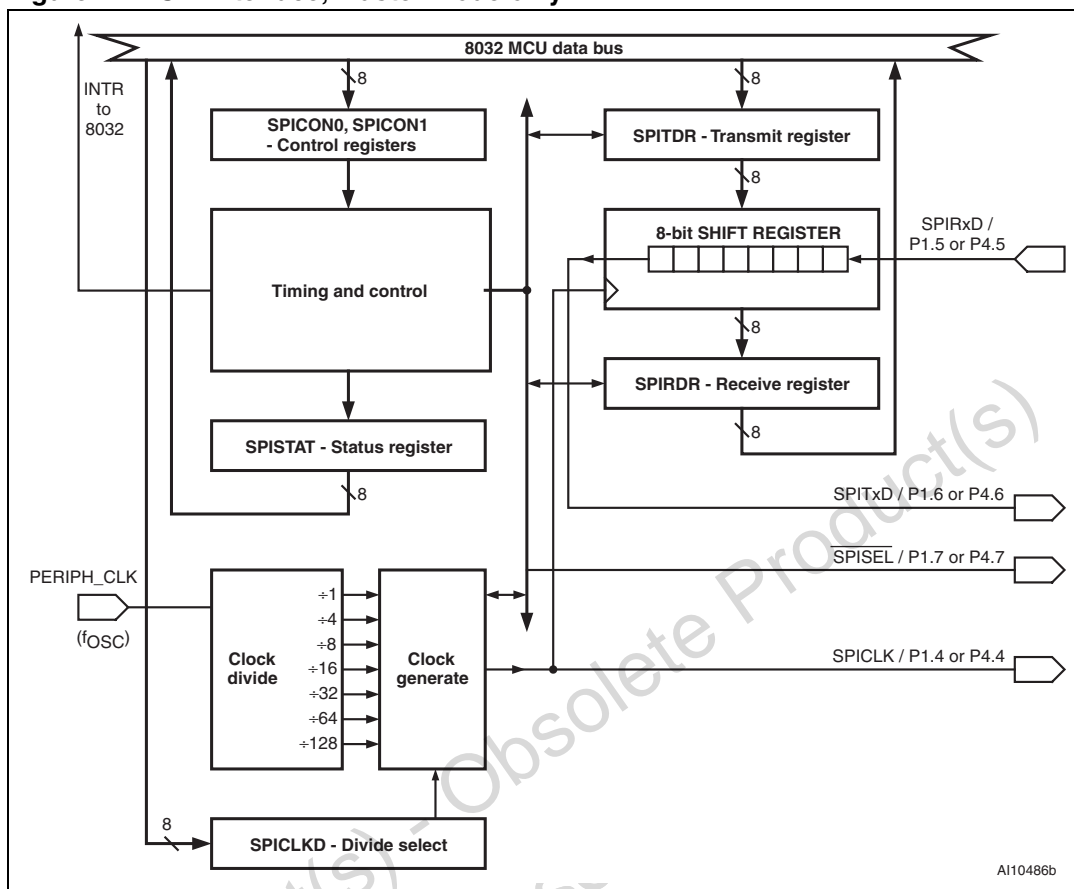

24.5 SPI configuration

The SPI interface is reset by the MCU reset, and firmware needs to initialize the SFRs SPICON0, SPICON1, and SPICLKD to define several operation parameters.

The SPO Bit in SPICON0 determines the clock polarity. When SPO is set to '0,' a data bit is transmitted on SPITxD from one rising edge of SPICLK to the next and is guaranteed to be valid during the falling edge of SPICLK. When SPO is set to '1,' a data bit is transmitted on SPITxD from one falling edge of SPICLK to the next and is guaranteed to be valid during the rising edge of SPICLK. The UPSD34xx will sample received data on the appropriate edge of SPICLK as determined by SPO. The effect of the SPO Bit can be seen in [Figure 45](#) and [Figure 46 on page 145](#).

The FLSB Bit in SPICON0 determines the bit order while transmitting and receiving the 8-bit data. When FLSB is '0,' the 8-bit data is transferred in order from MSB (first) to LSB (last). When FLSB Bit is set to '1,' the data is transferred in order from LSB (first) to MSB (last).

The clock signal generated on SPICLK is derived from the internal PERIPH_CLK signal. PERIPH_CLK always operates at the frequency, f_{OSC} , and runs constantly except when stopped in MCU Power Down mode. SPICLK is a result of dividing PERIPH_CLK by a sum of different divisors selected by the value contained in the SPICLKD register. The default value in SPICLKD after a reset divides PERIPH_CLK by a factor of 4. The bits in SPICLKD can be set to provide resulting divisor values in of sums of multiples of 4, such as 4, 8, 12,

16, 20, all the way up to 252. For example, if SPICLKD contains 24h, SPICLK has the frequency of PERIH_CLK divided by 36 decimal.

The SPICLK frequency must be set low enough to allow the MCU time to read received data bytes without losing data. This is dependent upon many things, including the crystal frequency of the MCU and the efficiency of the SPI firmware.

24.6 Dynamic control

At runtime, bits in registers SPICON0, SPICON1, and SPISTAT are managed by firmware for dynamic control over the SPI interface. The bits Transmitter Enable (TE) and Receiver Enable (RE) when set will allow transmitting and receiving respectively. If TE is disabled, both transmitting and receiving are disabled because SPICLK is driven to constant output logic '0' (when SPO = 0) or logic '1' (when SPO = 1).

When the SSEL Bit is set, the SPISEL pin will drive to logic '0' (active) to select a connected slave device at the appropriate time before the first data bit of a byte is transmitted, and SPISEL will automatically return to logic '1' (inactive) after transmitting the eight bit of data, as shown in *Figure 46 on page 145*. SPISEL will continue to automatically toggle this way for each byte data transmission while the SSEL bit is set by firmware. When the SSEL Bit is cleared, the SPISEL pin will drive to constant logic '1' and stay that way (after a transmission in progress completes).

The Interrupt Enable Bits (TEIE, RORIE, TIE, and RIE) when set, will allow an SPI interrupt to be generated to the MCU upon the occurrence of the condition enabled by these bits. Firmware must read the four corresponding flags in the SPISTAT register to determine the specific cause of interrupt. These flags are automatically cleared when firmware reads the SPISTAT register.

Table 89. SPICON0: control register 0 (SFR D6h, reset value 00h)

Bit 7	Bit 6	Bit 5	Bit 4	Bit 3	Bit 2	Bit 1	Bit 0
–	TE	RE	SPIEN	SSEL	FLSB	SBO	–

Table 90. SPICON0 register bit definition

Bit	Symbol	R/W	Definition
7	–	–	Reserved
6	TE	RW	Transmitter Enable 0 = Transmitter is disabled 1 = Transmitter is enabled
5	RE	RW	Receiver Enable 0 = Receiver is disabled 1 = Receiver is enabled
4	SPIEN	RW	SPI Enable 0 = Entire SPI Interface is disabled 1 = Entire SPI Interface is enabled

Table 90. SPICON0 register bit definition (continued)

Bit	Symbol	R/W	Definition
3	SSEL	RW	Slave Selection 0 = $\overline{\text{SPISEL}}$ output pin is constant logic '1' (slave device not selected) 1 = $\overline{\text{SPISEL}}$ output pin is logic '0' (slave device is selected) during data transfers
2	FLSB	RW	First LSB 0 = Transfer the most significant bit (MSB) first 1 = Transfer the least significant bit (LSB) first
1	SPO	–	Sampling Polarity 0 = Sample transfer data at the falling edge of clock (SPICLK is '0' when idle) 1 = Sample transfer data at the rising edge of clock (SPICLK is '1' when idle)
0	–	–	Reserved

Table 91. SPICON1: SPI interface control register 1 (SFR D7h, reset value 00h)

Bit 7	Bit 6	Bit 5	Bit 4	Bit 3	Bit 2	Bit 1	Bit 0
–	–	–	–	TEIE	RORIE	TIE	RIE

Table 92. SPICON1 register bit definition

Bit	Symbol	R/W	Definition
7-4	–	–	Reserved
3	TEIE	RW	Transmission End Interrupt Enable 0 = Disable Interrupt for Transmission End 1 = Enable Interrupt for Transmission End
2	RORIE	RW	Receive Overrun Interrupt Enable 0 = Disable Interrupt for Receive Overrun 1 = Enable Interrupt for Receive Overrun
1	TIE	RW	Transmission Interrupt Enable 0 = Disable Interrupt for SPITDR empty 1 = Enable Interrupt for SPITDR empty
0	RIE	RW	Reception Interrupt Enable 0 = Disable Interrupt for SPIRDR full 1 = Enable Interrupt for SPIRDR full

Table 93. SPICLKD: SPI prescaler (clock divider) register (SFR D2h, reset value 04h)

Bit 7	Bit 6	Bit 5	Bit 4	Bit 3	Bit 2	Bit 1	Bit 0
DIV128	DIV64	DIV32	DIV16	DIV8	DIV4	–	–

Table 94. SPICLKD register bit definition

Bit	Symbol	R/W	Definition
7	DIV128	RW	0 = No division 1 = Divide f_{OSC} clock by 128
6	DIV64	RW	0 = No division 1 = Divide f_{OSC} clock by 64
5	DIV32	RW	0 = No division 1 = Divide f_{OSC} clock by 32
4	DIV16	RW	0 = No division 1 = Divide f_{OSC} clock by 16
3	DIV8	RW	0 = No division 1 = Divide f_{OSC} clock by 8
2	DIV4	RW	0 = No division 1 = Divide f_{OSC} clock by 4
1-0	Not Used	–	

Table 95. SPISTAT: SPI interface status register (SFR D3h, reset value 02h)

Bit 7	Bit 6	Bit 5	Bit 4	Bit 3	Bit 2	Bit 1	Bit 0
–	–	–	BUSY	TEISF	RORISF	TISF	RISF

Table 96. SPISTAT register bit definition

Bit	Symbol	R/W	Definition
7-5	–	–	Reserved
4	BUSY	R	SPI Busy 0 = Transmit or Receive is completed 1 = Transmit or Receive is in process
3	TEISF	R	Transmission End Interrupt Source flag 0 = Automatically resets to '0' when firmware reads this register 1 = Automatically sets to '1' when transmission end occurs
2	RORISF	R	Receive Overrun Interrupt Source flag 0 = Automatically resets to '0' when firmware reads this register 1 = Automatically sets to '1' when receive overrun occurs
1	TISF	R	Transfer Interrupt Source flag 0 = Automatically resets to '0' when SPITDR is full (just after the SPITDR is written) 1 = Automatically sets to '1' when SPITDR is empty (just after byte loads from SPITDR into SPI shift register)
0	RISF	R	Receive Interrupt Source flag 0 = Automatically resets to '0' when SPIRDR is empty (after the SPIRDR is read) 1 = Automatically sets to '1' when SPIRDR is full

25 USB interface

UPSD34xx devices provide a full speed USB (Universal Serial Bus) device interface. The serial interface engine (SIE) provides the interface between the CPU and the USB (see [Figure 48](#)).

- Note:*
- 1 For a list of known limitations of USB interface for UPSD34xx devices, please refer to [Section 34: Important notes on page 294](#).
 - 2 Please make sure you have the latest 3400 USB firmware.

The USB module supports the following features:

- USB 2.0 compliant to full-speed mode (12 Mbps)
- 3.3 V USB transceiver
- Five endpoints including Control endpoint 0
 - Each endpoint includes two 64 byte FIFOs, one for IN and one for OUT transactions
 - Endpoints 1 through 4 support Interrupt and Bulk transfers
- USB Bus Suspend detection and Resume generation
- PLL Multiplier to generate the 48 MHz as required for USB support.
- Interrupts for various USB bus conditions.
- Performs NRZI encoding and decoding, bit stuffing, CRC generation and checking, and serial/parallel data conversion
- Double buffering (using FIFO pairing) for efficient data transfer in Bulk transfer
- Busy bit-based FIFO status monitoring
- FIFOs accessible via XDATA space

The analog front-end of the USB module is an on-chip USB transceiver. It is designed to allow voltage levels equal to V_{DD} from the standard logic to interface with the physical layer of the USB. It is capable of receiving and transmitting serial data at full speed (12 Mb/s).

The SIE is the digital-front-end of the USB block. This module recovers the 12MHz clock, detects the USB sync word, and handles all low-level USB protocols and error checking. The bit-clock recovery circuit recovers the clock from the incoming USB data stream and is able to track jitter and frequency drift according to the USB specifications.

The SIE also translates the electrical USB signals into bytes or signals. When there is a USB device address match, the USB data is directed to an endpoint's FIFO for OUT transactions and read from an endpoint's FIFO for IN transactions. Control transfers are supported on Endpoint0 and interrupt and bulk data transfers are supported on Endpoints1 through 4. The device's USB address and the enabling of the endpoints are programmable using the SIE's SFRs.

Important note: The USB SIE requires a 48MHz clock to operate properly. A PLL is included in the UPSD34xx that must be programmed appropriately based on the input clock to provide a 48MHz clock to the SIE (see [Section 14.2.2: USB_CLK on page 69](#) to set up the PLL).

Figure 48. USB module block diagram

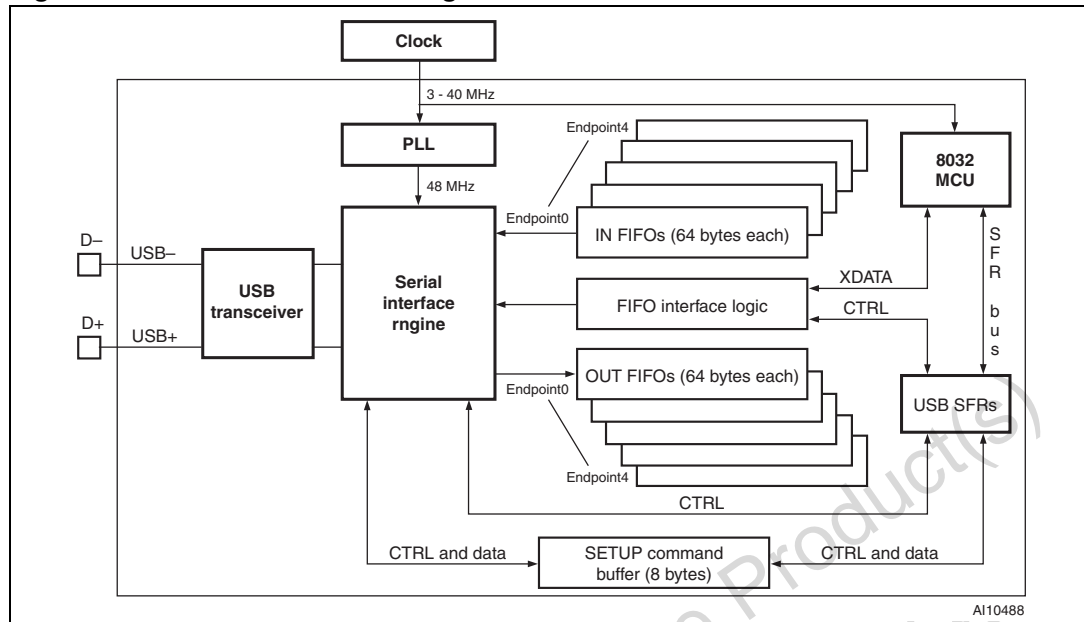

25.1 Basic USB concepts

The Universal Serial Bus (USB) is more complex than the standard serial port and requires familiarity with the specification to fully understand how to use the USB peripheral in the UPSD34xx. The USB specification is available on the Internet at <http://www.usb.org>. Some basic concepts will be presented in this section but knowledge of the USB specification is required.

In a USB system, there is only one master and the master is the host computer. The host controls all activity on the bus and devices respond to requests from the host. The only exception is when a device has been put into a low power suspend mode by the host. In this case, the device can signal a remote wakeup. Outside of that exception, all activity is controlled and initiated by the host. The host-centric model versus a peer-to-peer model provides the best way to develop low cost peripherals by keeping the complex control logic on the host side. The UPSD34xx is a peripheral (non-host) device.

25.1.1 Communication flow

The USB provides a means for communication between host (client) software and a function on a USB device. Functions can have different requirements for the communication flow depending on the client software to the USB function interaction. With USB, the various communication flows are separated to provide better bus utilization. For example, one communication flow is used for managing the device while another is for transferring data related to the operation of the device. Some bus access is used for each communication flow with each flow terminated at an endpoint on a device. Each endpoint has various aspects associated with the communication flow. A USB device looks like a collection of endpoints to the USB system.

25.1.2 Endpoints

Each USB device contains a collection of independent endpoints, with an endpoint being the destination of a communication flow between client software and the device. By design, each USB device's endpoints are given specific unique identifiers called endpoint numbers. In addition, each endpoint has an associated direction for the data flow, either in (from device to host) or out (from host to device). At the time a device is connected to the USB, it is assigned a unique address. The combination of the device address, endpoint number, and direction allows each endpoint to be uniquely referenced.

Each endpoint has some associated characteristics for the communication flow with the client software running on the host. Those characteristics include:

- Endpoint number;
- Frequency and latency requirements;
- Bandwidth requirements;
- Maximum packet size capability;
- Error handling requirements;
- Data transfer direction; and
- Transfer type.

All USB devices are required to implement a default control method that uses both the input and output endpoints with Endpoint zero. The USB System Software uses this default control method to initialize and generically manipulate the logical device as the Default Control Pipe. Endpoint zero is always accessible and provides access to the device's configuration and status information as well as some basic control access.

Additional (non-zero) endpoints provide the communication flow required for the functionality of the device. The non-zero endpoints are available for use only after the device is configured per the normal device configuration process (see Chapter 9 of the USB specification, <http://www.usb.org>).

25.1.3 Packets

USB transactions consist of data packets that contain special codes called Packet IDs (PIDs). A PID signifies the kind of packet that is being transmitted. While there are more types of PIDs in a USB system, the UPSD34xx responds to the three types shown in [Table 97](#)

Table 97. Types of packet IDs

PID type	PID name
Token	IN, OUT, SETUP
Data	DATA0, DATA1
Handshake	ACK, NAK, STALL

[Figure 49](#) shows an example of packets sent during a USB transfer. The first packet is a Token Packet with an OUT PID. The OUT PID indicates that the host is going to send data to the addressed device's endpoint. The ADDR field contains the address of the device and the ENDP field contains the endpoint within the addressed device. The CRC5 is a Cyclic Redundancy Check for error checking.

The data packet contains a DATA1 or DATA0 PID. In a USB system, the host or device that is sending data is responsible for toggling the data PID between DATA0 and DATA1. The receiving device keeps track of the Toggle Bit and compares it with the data PID that is received. This provides a means for the receiving host or device to detect a corrupted handshake packet. The Payload Data is the data that the host is sending to the device and the CRC16 is used for error checking.

For an OUT transaction, the host sends the token and data packets. The receiving device sends a handshake packet to notify the host whether it was able to accept the packet or not. There are three handshake PIDs as follows:

- ACK: this PID indicates that the device received the data successfully.
- NAK: this handshake indicates that the device was not able to receive the data (it is busy). A NAK does not mean there was an error, since errors are indicated by a “no handshake” packet. When the host receives a NAK PID or does not receive a handshake packet at all, the host retries sending the data at a later time.
- STALL: this handshake indicates that something is wrong. For example, the host has sent a device request that is not understood, the host is trying to access a resource that is not available, or something is wrong with the device.

Figure 49. USB packets in a USB transfer example

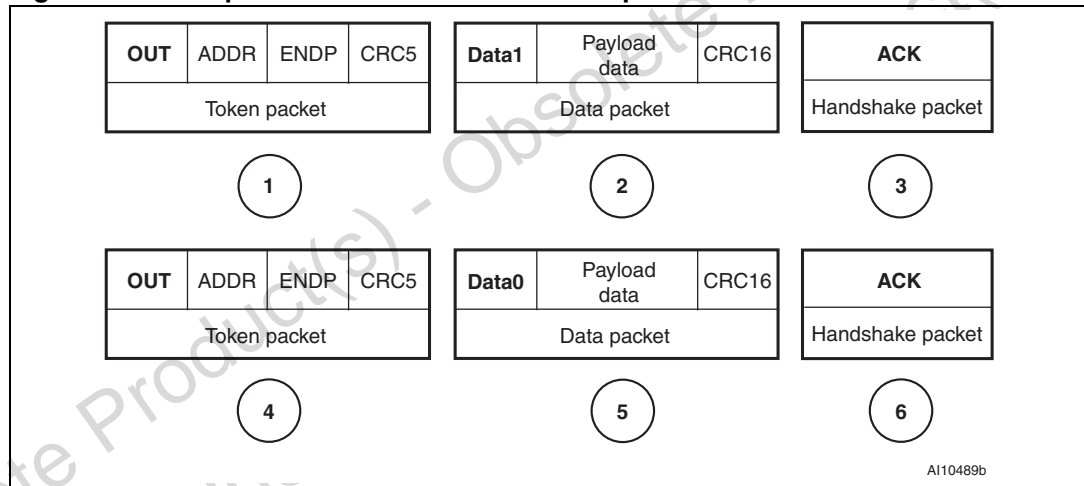

25.1.4 Data transfers with the host

The host issues OUT tokens followed by Data Tokens to send data to a device. The device responds with an appropriate handshake packet (ACK/NAK), indicating whether it was able to receive the data. If the device does not receive the data packet OK (because there is some error), it does not respond with a handshake packet. In the case of a NAK or no response, the host retries sending the data at a later time.

USB devices are not able to send data to a host whenever they have it ready. When a device has data ready, it loads data into its endpoint buffer, making it ready for a transfer. The data will remain in the buffer until the host issues an IN token to that device’s endpoint, at which time the data will be sent. If the host receives the data OK, it follows with an ACK handshake (a host never NAKs). If the host did not receive the data OK, there is no handshake packet. In this case, the device should reload its endpoint buffer as appropriate and the host will retry again later to retrieve the data.

25.2 Types of transfers

The USB specification defines four types of transfers, Bulk, Interrupt, Isochronous, and Control.

Note: The UPSD34xx supports all types of transfers except Isochronous.

- Bulk Transfers** (see [Figure 50](#))
 Bulk data is transferred in both directions and is used with both IN and OUT endpoints. Packets may be 8, 16, 32, or 64 bytes in length. Bulk transfers occur in bursts, and are scheduled by the host when there is available time on the bus. While there is no guaranteed delivery time for bulk transfers, the accuracy of the data is guaranteed due to automatic retries for erroneous data. Bulk transfers are typically used for mass storage, printer, and scanner data.
- Interrupt Transfers** (see [Figure 51](#))
 Interrupt data is a lot like bulk data but travels only in one direction, from the device to the host, so only IN endpoints are used. Interrupt data holds packet sizes ranging from 1 to 64 bytes. Interrupt endpoints have an associated polling interval, meaning that the host sends IN tokens at a periodic interval to the host on a regular basis. Interrupt transfers are typically used for human interface devices such as keyboards, mice, and joysticks.

Figure 50. IN and OUT bulk transfers

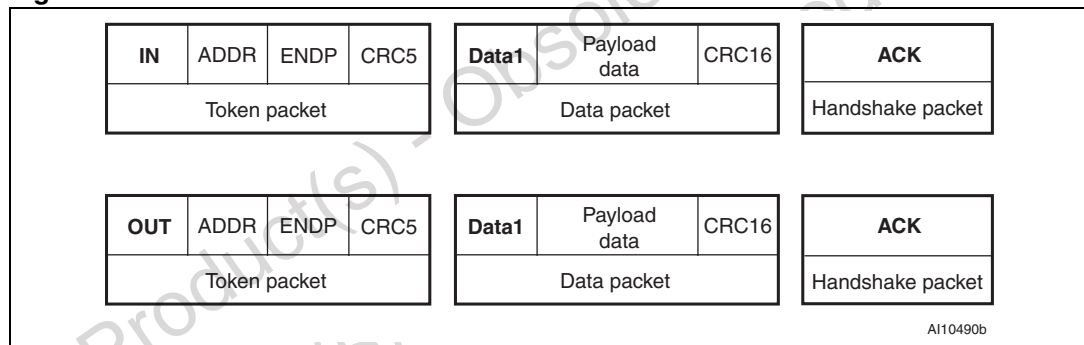
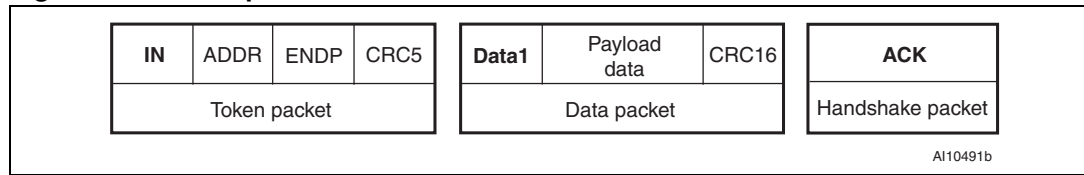

Figure 51. Interrupt transfer



- Control Transfers (see [Figure 52](#))
 - Control transfers are used to configure and send commands to a device. Control transfers consist of two or three stages:
 - SETUP
 - This stage always consists of a data packet with eight bytes of USB CONTROL data.
 - DATA stage (optional)
 - If the CONTROL data is such that the host is requesting information from the device, the SETUP stage is followed by a DATA stage. In this case, the host sends an IN token and the device responds with the requested data in the data packet.
 - STATUS stage
 - This stage is essentially a handshake informing the device of a successfully completed control operation.

25.2.1 Enumeration

Enumeration is the process that takes place when a device is first connected to the USB. During enumeration, the host requests information from the device about what it is, how many endpoints it has, the power requirements, bus bandwidth requirements, and what driver to load. Once the enumeration process is complete, the device is available for use.

The enumeration process consists of a series of six steps as follows:

1. When a device is first connected to the USB, its address is zero. Upon detecting a new device connected to the USB, the host sends a Get_Descriptor request to address zero, endpoint0.
2. The device, upon receiving a Get_Descriptor request, sends data back to the host identifying what it is.
3. The host resets the device and then sends a Set_Address request. This is a unique address that identifies it from all other devices connected to the USB. This address remains in effect until the device is disconnected from the USB.
4. The host sends more Get_Descriptor requests to the device to gather more detailed information about it and then loads the specified driver.
5. The host will setup and enable the endpoints defined by the device.
6. The device is now configured and ready for use with the host communicating to the device using the assigned address and endpoints.

Figure 52. Control transfer

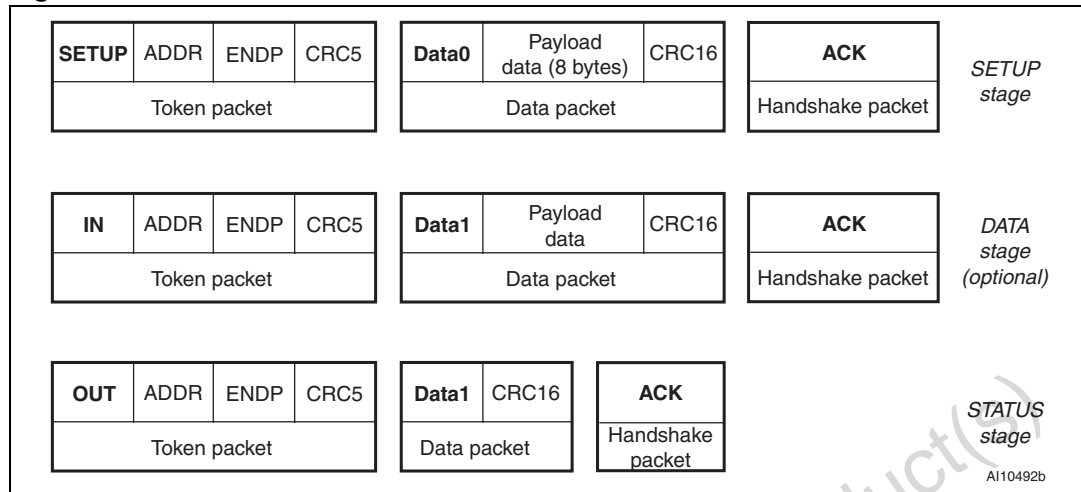

25.3 Endpoint FIFOs

The UPSD34xx's USB module includes 5 endpoints and 10 FIFOs. Each endpoint has two FIFOs with one for IN and the other for OUT transactions. Each FIFO is 64 bytes long and is selectively made visible in a 64-byte XDATA segment for CPU access. For efficient data transfers, the FIFOs may be paired for double buffering. With double buffering, the CPU may operate on the contents in one buffer while the SIE is transmitting or receiving data in the paired buffer. UPSD34xx supported endpoints and FIFOs are shown in [Table 98](#)

25.3.1 Busy bit (BSY) operation

Each FIFO has a busy bit (BSY) that indicates when the USB SIE has ownership of the FIFO. When the SIE has ownership of the FIFO, it is either writing data to or reading data from the FIFO. The SIE writes data to the FIFO when it is receiving an OUT packet and reads data from the FIFO when it is sending data in response to an IN packet. The CPU is only permitted to access the FIFO when it is not busy and accesses to it while busy are ignored. Once the IN FIFO has been written with data by the CPU, the CPU updates the USIZE register with the number of bytes written to the FIFO. The value written to the USIZE register tells the SIE the number of bytes to send to the host in response to an IN packet. Once the USIZE register is written, the FIFOs busy bit is set and remains set until the data has been transmitted in response to an IN packet. The busy bit for an OUT FIFO is set as soon as the SIE starts receiving an OUT packet from the host. Once all the data has been received and written to the FIFO, the SIE clears the busy bit and writes the number of bytes received to the USIZE register.

25.3.2 Busy bit and interrupts

When the FIFO's interrupt is enabled, a transition of the busy bit from a '1' to a '0' (when ownership of the FIFO changes from the SIE to the CPU) generates a USB interrupt with the corresponding flag set. For an interrupt on an IN FIFO, the CPU must fill the FIFO with the next set of data to be sent and then update the USIZE register with the number of bytes to send. For an interrupt on an OUT FIFO, the CPU reads the USIZE register to determine the number of bytes received and then reads that number of data bytes out of the FIFO.

Table 98. UPSD34xx supported endpoints

Endpoint	Function	Max packet size (FIFO size)	Supported directions
0	Control	64 bytes	OUT
0	Control	64 bytes	IN
1	Bulk/Interrupt OUT	64 bytes	OUT
1	Bulk/Interrupt IN	64 bytes	IN
2	Bulk/Interrupt OUT	64 bytes	OUT
2	Bulk/Interrupt IN	64 bytes	IN
3	Bulk/Interrupt OUT	64 bytes	OUT
3	Bulk/Interrupt IN	64 bytes	IN
4	Bulk/Interrupt OUT	64 bytes	OUT
4	Bulk/Interrupt In	64 bytes	IN

25.3.3 FIFO pairing

The FIFOs on endpoints 1 through 4 may be used independently as shown in [Figure 53](#) as FIFOs with no Pairing or they may be selectively paired to provide double buffering (see [Figure 54 on page 159](#)). Double buffering provides an efficient way to optimize data transfer rates with bulk transfers. Double buffering allows the CPU to process a data packet for an Endpoint while the SIE is receiving or transmitting another packet of data on the same Endpoint and direction. FIFO pairing is controlled by the USB pairing control register (see UPAIR, [Table 102 on page 162](#)). FIFO pairing options are listed below:

- IN FIFO 1 and 2
- OUT FIFO 1 and 2
- IN FIFO 3 and 4
- OUT FIFO 3 and 4

Note: When the FIFOs are paired, the CPU must access the odd numbered FIFO while the even numbered FIFOs are no longer available for use. Also when they are paired, the active FIFO is automatically toggled by the update of USIZE.

- Non-pairing FIFOs Example

Consider a case where the device needs to send 1024 bytes of data to the host. Without FIFO pairing (see [Figure 53](#)), the CPU loads the IN Endpoint0 FIFO with 64 bytes of data and waits until the host sends an IN token to Endpoint0, and the SIE transfers the data to the host. Once all 64 bytes have been transferred by the SIE, the FIFO becomes empty and the CPU starts writing the next 64 bytes of data to the FIFO. While the CPU is writing the data to the FIFO, the host is sending IN tokens to Endpoint0, requesting the next 64 bytes of data, but only gets NAKs while the FIFO is being loaded. Once the FIFO has been loaded by the CPU, the SIE starts sending the data to the host with the next IN Endpoint0 token. Again, the CPU waits until the SIE transfers the 64 bytes of data to the host. This is repeated until all 1024 bytes have been transferred.

Figure 53. FIFOs with no pairing

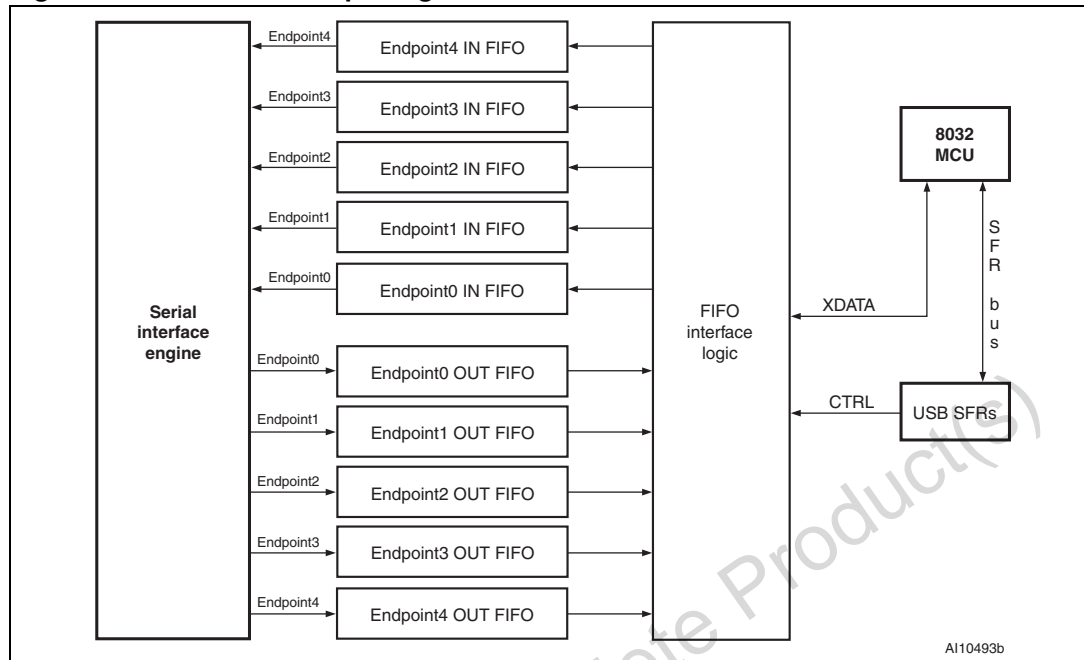

- Pairing FIFOs example

Now assume that IN Endpoint1 and Endpoint2 FIFOs are paired for double buffering and the same 1024 bytes of data are to be transferred to the host. As in the non-pairing example, the CPU loads the IN Endpoint0 FIFO with 64 bytes of data. Instead of having to wait for the SIE to transfer the 64 bytes of data to the host, the CPU can write another 64 bytes of data to IN Endpoint0 FIFO. While the CPU is writing the second packet of 64 bytes of data into the FIFO, the SIE is sending the first packet of 64 bytes of data to the host. After the CPU has written the second packet of 64 bytes to the FIFO, it waits a shorter amount of time for the SIE to complete sending the first packet of data since they were working concurrently. As soon as the first packet is sent by the SIE, the second packet is immediately available to be sent by the SIE since the FIFO was already loaded by the MCU. Also, after the first packet is sent by the SIE, the alternate FIFO is available for the MCU to load the third packet of 64 bytes of data. With double buffering, the MCU is able to always have a FIFO loaded and ready with data to be sent by the SIE when the host sends an IN token maximizing the data transfer rate.

Figure 54. FIFO pairing example (1/2 IN paired and 3/4 OUT paired)

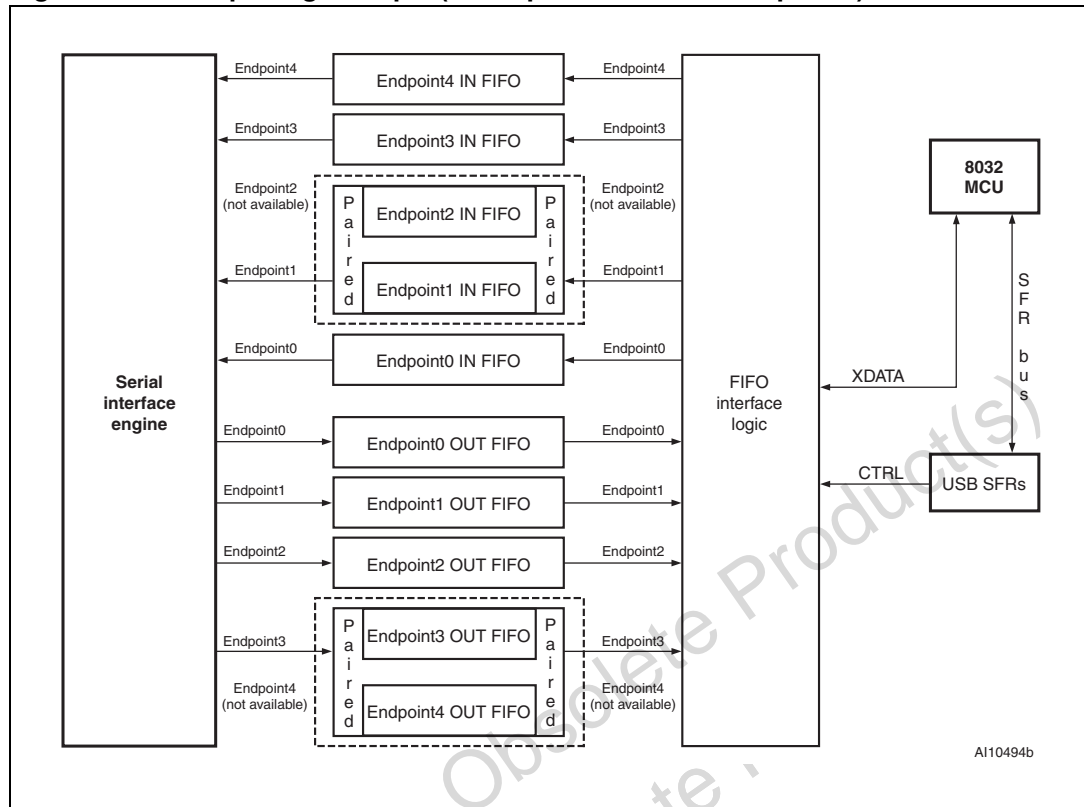

25.3.4 Reading and writing FIFOs

There are a total of ten 64-byte FIFOs. Each of the five Endpoints has two FIFOs, one IN FIFO for IN transactions and one OUT FIFO for OUT transactions. The FIFOs are accessible by the CPU through a 64-byte segment in the XDATA space when the VISIBLE Bit is set (see [Table 120 on page 170](#)). If the VISIBLE Bit is not set, the FIFOs are not accessible by the CPU but are still accessible by the SIE. The base address of the 64-byte segment is specified by the USB base address high register (see [Table 130 on page 175](#)) and the USB base address low register (see [Table 132 on page 175](#)). When the VISIBLE Bit is set, the FIFO that is accessible in the 64-byte XDATA space segment is the FIFO selected by the USEL register. The USEL register contains two fields used for selecting the accessible FIFO. The EP field determines the Endpoint selected and the DIR Bit selects the IN or OUT FIFO associated with the Endpoint.

25.3.5 Accessing FIFO control registers, UCON, and USIZE

Each of the 10 Endpoint FIFOs has an associated USB endpoint control register (UCON, 0F1H) and a USB FIFO valid size register (USIZE, 0F2H). The USB endpoint select register (USEL) is not only used to select the Endpoint FIFO that is accessible in the XDATA space, but also selects the associated Endpoint's UCON and USIZE registers that are accessible at SFR addresses 0F1H and 0F2H.

25.3.6 Accessing the setup command buffer

Setup Packets are sent from the host to a device's Endpoint0 and consist of 8 bytes of command data. When the SIE receives a Setup packet from the host, it stores the 8 bytes of data in the Command Buffer. The command buffer is accessed via the indexed USB Setup Command Value register (USCV). The USB Setup Command Index register (USCI) is used to select the byte from the command buffer that is read when accessing the USCV register.

25.4 USB registers

The USB module is controlled via registers mapped into the SFR space. The USB SFRs consist of the following:

- UADDR: USB device address
- UPAIR: USB FIFO pairing control
- UIE0~3: USB interrupt enable
- UIF0~3: USB interrupt flags
- UCTL: USB control
- USTA: USB status
- USEL: USB endpoint and direction select
- UCON: USB selected FIFO control register
- USIZE: USB selected FIFO size register
- UBASE: USB base address register
- USCI: USB setup command index
- USCV: USB setup command value

The memory map for the USB SFRs, the individual bit names, and the reset values are shown in [Table 99](#).

Table 99. UPSD34xx USB SFR register map⁽¹⁾

SFR addr (hex)	SFR name	Bit name and <bit address>								Reset value (hex)	Comment
		7	6	5	4	3	2	1	0		
E2	UADDR	USBADDR[6:0]								00	USB Address
E3	UPAIR	-	-	-	-	PR3OUT	PR1OUT	PR3IN	PR1IN	00	USB Pairing Control
E4	UIE0	-	-	-	-	RSTIE	SUSPNDIE	EOPIE	RESUMIE	00	USB Global Interrupt Enable
E5	UIE1	-	-	-	IN4IE	IN3IE	IN2IE	IN1IE	IN0IE	00	USB IN FIFO Interrupt Enable
E6	UIE2	-	-	-	OUT4IE	OUT3IE	OUT2IE	OUT1IE	OUT0IE	00	USB OUT FIFO Interrupt Enable
E7	UIE3	-	-	-	NAK4IE	NAK3IE	NAK2IE	NAK1IE	NAK0IE	00	USB IN FIFO NAK Int. Enable

Table 99. UPSD34xx USB SFR register map⁽¹⁾ (continued)

SFR addr (hex)	SFR name	Bit name and <bit address>								Reset value (hex)	Comment
		7	6	5	4	3	2	1	0		
E8	UIF0	GLF	INF	OUTF	NAKF	RSTF	SUSPNDF	EOPF	RESUMF	00	USB Global Interrupt Flag
E9	UIF1	-	-	-	IN4F	IN3F	IN2F	IN1F	IN0F	00	USB IN FIFO Interrupt Flag
EA	UIF2	-	-	-	OUT4F	OUT3F	OUT2F	OUT1F	OUT0F	00	USB OUT FIFO Interrupt Flag
EB	UIF3	-	-	-	NAK4F	NAK3F	NAK2F	NAK1F	NAK0F	00	USB IN FIFO NAK Int. Flag
EC	UCTL	-	-	-	-	-	USBEN	VISIBLE	WAKEUP	00	USB Control
ED	USTA	-	-	-	-	RCVT	SETUP	IN	OUT	00	USB Status
EE	RESERVED										
EF	USEL	DIR	-	-	-	-	EP[2:0]			00	USB Endpoint Select
F1	UCON	-	-	-	-	ENABLE	STALL	TOGGLE	BSY	08	USB Endpoint Control
F2	USIZE	-	SIZE[6:0]							00	USB FIFO Valid Size
F3	UBASEH	BASEADDR[15:8]								00	USB Base Address High
F4	UBASEL	BASEADDR [7:6]	0	0	0	0	0	0	0	00	USB Base Address Low
F5	USCI	-	-	-	-	USC[2:0]				00	USB Setup Command Index
F6	USCV	USCV[7:0]								00	USB Setup Command Value

1. Bits marked with a “-“ are Reserved.

25.4.1 USB device address register

Initially when a device is connected to the USB, it responds to the host on address 0. Using the Set_Address request, the host assigns a unique address to the device. The firmware writes this address to the USB Device Address register (see [Table 100](#)), and subsequently the SIE only responds to transactions on that assigned address. This assigned address is in effect until the device or an upstream hub is disconnected from the USB, the host issues a USB Reset, or the host shuts down. The address register is cleared with a Hardware RESET. When a USB RESET is detected, the address register should be cleared.

25.4.2 Endpoint FIFO pairing

Endpoint FIFOs can be paired for double buffering to provide an efficient method for bulk data transfers. With double buffering enabled, the MCU can operate on one data packet while another is being transferred over USB.

When two FIFOs are paired, the active FIFO is automatically toggled by the update of USIZE. The MCU must only use the odd numbered endpoint FIFO when paired in order to access the active FIFO. For example, if endpoints 3 and 4 OUT FIFOs are paired, the active FIFO is accessed via endpoint 3's OUT FIFO (see [Table 102](#)).

Table 100. USB device address register (UADDR 0E2h, reset value 00h)

Bit 7	Bit 6	Bit 5	Bit 4	Bit 3	Bit 2	Bit 1	Bit 0
–	USBADDR[6:0]						

Table 101. UADDR register bit definition

Bit	Symbol	R/W	Definition
7	–	–	Reserved
6:0	USBADDR	R/W	USB Address of the device. These bits are cleared with a Hardware RESET. When a USB RESET is detected, the address register should be cleared.

Table 102. Pairing control register (UPAIR 0E3h, reset value 00h)

Bit 7	Bit 6	Bit 5	Bit 4	Bit 3	Bit 2	Bit 1	Bit 0
–	–	–	–	PR3OUT	PR1OUT	PR3IN	PR1IN

Table 103. UPAIR register bit definition

Bit	Symbol	R/W	Definition
7	–	–	Reserved
6	–	–	Reserved
5	–	–	Reserved
4	–	–	Reserved
3	PR3OUT	R/W	Setting this bit enables double buffering of the OUT FIFOs for Endpoints 3 and 4. Access to the double buffered FIFOs is through Endpoint3's OUT FIFO.
2	PR1OUT	R/W	Setting this bit enables double buffering of the OUT FIFOs for Endpoints 1 and 2. Access to the double buffered FIFOs is through Endpoint1's OUT FIFO.
1	PR3IN	R/W	Setting this bit enables double buffering of the IN FIFOs for Endpoints 3 and 4. Access to the double buffered FIFOs is through Endpoint3's IN FIFO.
0	PR1IN	R/W	Setting this bit enables double buffering of the IN FIFOs for Endpoints 1 and 2. Access to the double buffered FIFOs is through Endpoint1's IN FIFO.

25.4.3 USB interrupts

There are many USB related events that generate an interrupt. The events that generate an interrupt are selectively enabled through the use of the USB interrupt enable registers. All USB interrupts are serviced through a single interrupt vector (see [Section 13: Interrupt system on page 62](#) for the address of the interrupt vector). When a USB interrupt occurs, firmware must check the USB interrupt flag registers to determine the source of the interrupt, clear that interrupt flag and process the interrupt before returning to the interrupted code.

The USB interrupt priority can be set to low or high. For the best USB response time and to maximize data transfer times, the USB interrupt should be set to the highest priority (see the [Section 13: Interrupt system](#) for the details on setting the interrupt priority).

- **USB Reset Interrupt**
The host signals a bus reset by driving both D+ and D- low for at least 10ms. When the UPSD34xx's SIE detects a reset on the USB, it generates the RST interrupt request. A USB reset does not reset the CPU nor the USB SIE, nor does it disable the USB SIE. The interrupt service routine should disable/enable the USB SIE to reset a portion of the state machine and initialize the USB SIE registers per the application requirements.
- **USB Suspend Interrupt**
If the UPSD34xx's SIE detects 3ms of no activity on the bus, it generates the SUSPEND interrupt request. It also causes the clock to the SIE to shut down to conserve power.
- **USB EOP (End of Packet) Interrupt**
Every packet sent on the USB includes a signal, called EOP, to indicate the end of the packet. When an EOP is detected, the SIE generates an EOP interrupt.
- **USB Resume Interrupt**
When USB activity is detected and the SIE is in the suspend state, a RESUME interrupt is generated. The USB Resume interrupt service routine should clear the SUSPENDF bit in the UIF0 register if it is set in order to turn the USB SIE clock on.
- **USB global interrupt enable register (UIE0)**
There are four USB events that are considered to be global in nature, meaning they are not specific to an endpoint, but apply to the USB bus in general. The four global USB events include Reset, Suspend, EOP, and Resume.
Each event can be enabled to generate an interrupt using the UIE0 register shown in [Table 104](#)

Table 104. USB global interrupt enable register (UIE0 0E4h, reset value 00h)

Bit 7	Bit 6	Bit 5	Bit 4	Bit 3	Bit 2	Bit 1	Bit 0
-	-	-	-	RSTIE	SUSPENDIE	EOPIE	RESUMIE

Table 105. UIE0 register bit definition

Bit	Symbol	R/W	Definition
7	–	–	Reserved
6	–	–	Reserved
5	–	–	Reserved
4	–	–	Reserved
3	RSTIE	R/W	Enable the USB Reset interrupt
2	SUSPEND IE	R/W	Enable the USB Suspend interrupt
1	EOPIE	R/W	Enable the USB EOP interrupt
0	RESUMIE	R/W	Enable the USB Resume interrupt

- USB IN FIFO interrupt enable register (UIE1)
When an endpoint's IN FIFO has been successfully sent to the host with an IN transaction, the FIFO becomes empty. The UIE1 register is used to enable each endpoint's IN FIFO interrupt ([Table 106](#)).
- USB OUT FIFO interrupt enable register (UIE2)
When an endpoint's OUT FIFO has been filled by an OUT transaction from the host, the FIFO becomes full. The UIE2 register is used to enable each endpoint's OUT FIFO interrupt ([Table 108](#)).

Table 106. USB IN FIFO interrupt enable register (UIE1 0E5h, reset value 00h)

Bit 7	Bit 6	Bit 5	Bit 4	Bit 3	Bit 2	Bit 1	Bit 0
–	–	–	IN4IE	IN3IE	IN2IE	IN1IE	IN0IE

Table 107. UIE1 register bit definition

Bit	Symbol	R/W	Definition
7	–	–	Reserved
6	–	–	Reserved
5	–	–	Reserved
4	IN4IE	R/W	Enable Endpoint 4 IN FIFO interrupt
3	IN3IE	R/W	Enable Endpoint 3 IN FIFO interrupt
2	IN2IE	R/W	Enable Endpoint 2 IN FIFO interrupt
1	IN1IE	R/W	Enable Endpoint 1 IN FIFO interrupt
0	IN0IE	R/W	Enable Endpoint 0 IN FIFO interrupt

Table 108. USB OUT FIFO interrupt enable register (UIE2 0E6h, reset value 00h)

Bit 7	Bit 6	Bit 5	Bit 4	Bit 3	Bit 2	Bit 1	Bit 0
–	–	–	OUT4IE	OUT3IE	OUT2IE	OUT1IE	OUT0IE

Table 109. UIE2 register bit definition

Bit	Symbol	R/W	Definition
7	–	–	Reserved
6	–	–	Reserved
5	–	–	Reserved
4	OUT4IE	R/W	Enable Endpoint 4 OUT FIFO interrupt
3	OUT3IE	R/W	Enable Endpoint 3 OUT FIFO interrupt
2	OUT2IE	R/W	Enable Endpoint 2 OUT FIFO interrupt
1	OUT1IE	R/W	Enable Endpoint 1 OUT FIFO interrupt
0	OUT0IE	R/W	Enable Endpoint 0 OUT FIFO interrupt

- **USB IN FIFO NAK interrupt enable register (UIE3)**

When an endpoint’s IN FIFO is empty and an IN transaction to that endpoint has been received, the SIE sends a NAK handshake token since there is no data ready for it to send.

The UIE3 register (see [Table 110](#)) is used to enable each endpoint’s IN FIFO NAK Interrupt.

Table 110. USB IN FIFO NAK interrupt enable register (UIE3 0E7h, reset value 00h)

Bit 7	Bit 6	Bit 5	Bit 4	Bit 3	Bit 2	Bit 1	Bit 0
–	–	–	NAK4IE	NAK3IE	NAK2IE	NAK1IE	NAK0IE

Table 111. UIE3 register bit definition

Bit	Symbol	R/W	Definition
7	–	–	Reserved
6	–	–	Reserved
5	–	–	Reserved
4	NAK4IE	R/W	Enable Endpoint 4 IN FIFO NAK interrupt
3	NAK3IE	R/W	Enable Endpoint 3 IN FIFO NAK interrupt
2	NAK2IE	R/W	Enable Endpoint 2 IN FIFO NAK interrupt
1	NAK1IE	R/W	Enable Endpoint 1 IN FIFO NAK interrupt
0	NAK0IE	R/W	Enable Endpoint 0 IN FIFO NAK interrupt

- USB global interrupt flag register (UIF0)

There are many different events that generate a USB interrupt requiring a number of registers to indicate the cause of the interrupt. To more efficiently identify the cause of the interrupt, the USB global interrupt flag register (see [Table 112](#)) indicates the type of interrupt that occurred. Once the type of interrupt is identified, the associated interrupt flag register may be read to determine the exact cause of the interrupt.

Table 112. USB global interrupt flag register (UIF0 0E8h, reset value 00h)

Bit 7	Bit 6	Bit 5	Bit 4	Bit 3	Bit 2	Bit 1	Bit 0
GLF	INF	OUTF	NAKF	RSTF	SUSPENDF	EOPF	RESUMF

Table 113. UIF0 register bit definition

Bit	Symbol	R/W	Definition
7	GLF	R	Global Interrupt flag Logical OR of the RSTF, SUSPENDF, EOPF, and RESUMF interrupt flags
6	INF	R	IN FIFO Interrupt flag Logical OR of the IN4F, IN3F, IN2F, IN1F, and IN0F interrupt flags
5	OUTF	R	OUT FIFO Interrupt flag Logical OR of the OUT4F, OUT3F, OUT2F, OUT1F, and OUT0F interrupt flags
4	NAKF	R	NAK FIFO Interrupt flag Logical OR of the NAK4F, NAK3F, NAK2F, NAK1F, and NAK0F interrupt flags
3	RSTF	R/W	USB Reset flag This bit is set when a USB Reset is detected on the D+ and D- lines. <i>Note: A USB Reset does not reset the MCU nor the USB module. Firmware should disable/enable the USB SIE using the USEN bit in the UCTL register and initialize all USB related registers as appropriate.</i>
2	SUSPENDF	R/W	USB suspend mode flag This bit is set when the SIE detects 3ms of no activity on the bus and the clock to the SIE is also shut down to conserve power. Clearing this bit turns the SIE clock on.
1	EOPF	R/W	End of Packet flag This bit is set when a valid End of Packet sequence is detected on the D+ and D- line.
0	RESUMEF	R/W	Resume flag This bit is set when USB bus activity is detected while the SUSPENDF Bit is set. When a Resume is detected, the SUSPENDF bit must be cleared (if set) to turn the SIE clock on.

- USB IN FIFO interrupt flag (UIF1)

The USB IN FIFO Interrupt Flag register (see [Table 114](#)) contains flags that indicate when an IN Endpoint FIFO that was full becomes empty. Once set, firmware must clear the flag by writing a '0' to the appropriate bit. When FIFOs are paired, only the odd numbered FIFO Interrupt flags are active.

Table 114. USB IN FIFO interrupt flag (UIF1 0E9h, reset value 00h)

Bit 7	Bit 6	Bit 5	Bit 4	Bit 3	Bit 2	Bit 1	Bit 0
–	–	–	IN4F	IN3F	IN2F	IN1F	IN0F

Table 115. UIF1 register bit definition

Bit	Symbol	R/W	Definition
7	–	–	Reserved
6	–	–	Reserved
5	–	–	Reserved
4	IN4F	R/W	Endpoint 4 IN FIFO Interrupt flag This bit is set when the FIFO status changes from full to empty.
3	IN3F	R/W	Endpoint 3 IN FIFO Interrupt flag This bit is set when the FIFO status changes from full to empty.
2	IN2F	R/W	Endpoint 2 IN FIFO Interrupt flag This bit is set when the FIFO status changes from full to empty.
1	IN1F	R/W	Endpoint 1 IN FIFO Interrupt flag This bit is set when the FIFO status changes from full to empty.
0	IN0F	R/W	Endpoint 0 IN FIFO Interrupt flag This bit is set when the FIFO status changes from full to empty.

- USB OUT FIFO interrupt flag (UIF2)
 The USB OUT FIFO Interrupt Flag register (see [Table 116](#)) contains flags that indicate when an OUT Endpoint FIFO that was empty becomes full. Once set, firmware must clear the flag by writing a '0' to the appropriate bit. When FIFOs are paired, only the odd numbered FIFO Interrupt flags are active.

Table 116. USB OUT FIFO interrupt flag (UIF2 0EAh, reset value 00h)

Bit 7	Bit 6	Bit 5	Bit 4	Bit 3	Bit 2	Bit 1	Bit 0
–	–	–	OUT4F	OUT3F	OUT2F	OUT1F	OUT0F

Table 117. UIF2 register bit definition

Bit	Symbol	R/W	Definition
7	–	–	Reserved
6	–	–	Reserved
5	–	–	Reserved
4	OUT4F	R/W	Endpoint 4 OUT FIFO Interrupt flag This bit is set when the FIFO status changes from empty to full.
3	OUT3F	R/W	Endpoint 3 OUT FIFO Interrupt flag This bit is set when the FIFO status changes from empty to full.
2	OUT2F	R/W	Endpoint 2 OUT FIFO Interrupt flag This bit is set when the FIFO status changes from empty to full.
1	OUT1F	R/W	Endpoint 1 OUT FIFO Interrupt flag This bit is set when the FIFO status changes from empty to full.
0	OUT0F	R/W	Endpoint 0 OUT FIFO Interrupt flag This bit is set when the FIFO status changes from empty to full.

- USB IN FIFO NAK interrupt flag (UIF3)
 The USB IN FIFO NAK Interrupt Flag register (see [Table 118](#)) contains flags that indicate when an IN Endpoint FIFO is not ready. The Endpoint FIFO is not ready when data has not been loaded into its FIFO and the USIZE register has not been written to (writing to the USIZE register puts the FIFO in a “ready” to send data state). Until the FIFO is ready, the SIE will continue to NAK all IN requests to the respective Endpoint. Once set, firmware must clear the flag by writing a '0' to the appropriate bit. When FIFOs are paired, only the odd numbered FIFO Interrupt Flags are active.

Table 118. USB IN FIFO NAK interrupt flag (UIF3 0EBh, reset value 00h)

Bit 7	Bit 6	Bit 5	Bit 4	Bit 3	Bit 2	Bit 1	Bit 0
–	–	–	NAK4F	NAK3F	NAK2F	NAK1F	NAK0F

Table 119. UIF3 register bit definition

Bit	Symbol	R/W	Definition
7	–	–	Reserved
6	–	–	Reserved
5	–	–	Reserved
4	NAK4F	R/W	Endpoint 4 IN FIFO NAK Interrupt flag This bit is set when the SIE responded to an IN request with a NAK since the FIFO was not ready.
3	NAK3F	R/W	Endpoint 3 IN FIFO NAK Interrupt flag This bit is set when the SIE responded to an IN request with a NAK since the FIFO was not ready.
2	NAK2F	R/W	Endpoint 2 IN FIFO NAK Interrupt flag This bit is set when the SIE responded to an IN request with a NAK since the FIFO was not ready.
1	NAK1F	R/W	Endpoint 1 IN FIFO NAK Interrupt flag This bit is set when the SIE responded to an IN request with a NAK since the FIFO was not ready.
0	NAK0F	R/W	Endpoint 0 IN FIFO NAK Interrupt flag This bit is set when the SIE responded to an IN request with a NAK since the FIFO was not ready.

- USB control register (UCTL)

The USB control register (see [Table 120](#)) is used to enable the SIE, make the Endpoint FIFOs visible in the XDATA space and for generating a remote wakeup signal. Upon a reset, the USB module is disabled and must be enabled by the CPU for communication with the host over the USB.

Table 120. USB control register (UCTL 0ECh, reset value 00h)

Bit 7	Bit 6	Bit 5	Bit 4	Bit 3	Bit 2	Bit 1	Bit 0
–	–	–	–	–	USBEN	VISIBLE	WAKEUP

Table 121. UCTL register bit definition

Bit	Symbol	R/W	Definition
7	–	–	Reserved
6	–	–	Reserved
5	–	–	Reserved
4	–	–	Reserved
3	–	–	Reserved
2	USBEN	R/W	<p>USB Enable</p> <p>When this bit is set, the USB function is enabled and the SIE responds to tokens from the host. When this bit is clear, the USB function is disabled and does not respond to any tokens from the host.</p> <p><i>Note: A USB reset does not clear this bit. Disabling and enabling the SIE using this bit resets part of the USB SIE state machine and some of the bits in the USTA and UCON registers.</i></p>
1	VISIBLE	R/W	<p>USB FIFO VISIBLE</p> <p>When this bit is set, the selected USB FIFO is accessible (visible) in the XDATA space.</p>
0	WAKEUP	R/W	<p>Remote Wakeup Enable</p> <p>This bit forces a resume or “K” state on the USB data lines to initiate a remote wake-up. The CPU is responsible for controlling the timing of the forced resume that must be between 10ms and 15ms. Setting this bit will not cause the RESUMF Bit to be set.</p>

- USB endpoint0 status (USTA)
 The USB Endpoint0 Status register (see [Table 122](#)) provides the status for events that occur on the USB that are directed to endpoint0.

Table 122. USB endpoint0 status (USTA 0EDh, reset value 00h)

Bit 7	Bit 6	Bit 5	Bit 4	Bit 3	Bit 2	Bit 1	Bit 0
–	–	–	–	RCVT	SETUP	IN	OUT

Table 123. USTA register bit definition

Bit	Symbol	R/W	Definition
7	–	–	Reserved
6	–	–	Reserved
5	–	–	Reserved
4	–	–	Reserved
3	RCVT	R	Received Data Toggle Bit This bit indicates the toggle bit of the received data packet: 0 = Data0, and 1 = Data1
2	SETUP	R/W	SETUP Token Detect Bit This bit is set when Endpoint0 receives a SETUP token. This bit is not cleared when Endpoint0 receives an IN or OUT token following the SETUP token that set this bit. This bit is cleared by software or a reset.
1	IN	R	IN Token Detect Bit This bit is set when Endpoint0 receives an IN token. This bit is cleared when Endpoint0 receives a SETUP or OUT token.
0	OUT	R	OUT Token Detect Bit This bit is set when Endpoint0 receives an OUT token. This bit is cleared when Endpoint0 receives a SETUP or IN token.

Caution: Disabling and enabling the USB SIE using the USBEN bit in the UCTL register clears the RCVT, IN, and OUT bits in this register.

- USB endpoint select register (USEL)
Endpoints share the same XDATA space for FIFOs as well as the same SFR addresses for Control and FIFO Valid Size registers. The USB endpoint select register (see [Table 124](#)) is used to select the desired direction and endpoint that is accessed when reading or writing to the FIFO XDATA address space. This register is also used to select the direction and Endpoint when accessing the USB endpoint control register.

Table 124. USB endpoint select register (USEL 0EFh, reset value 00h)

Bit 7	Bit 6	Bit 5	Bit 4	Bit 3	Bit 2	Bit 1	Bit 0
DIR	–	–	–	–	EP[2]	EP[1]	EP[0]

Table 125. USEL register bit definition

Bit	Symbol	R/W	Definition
7	DIR	R/W	FIFO's Direction Select Bit: 0: IN FIFO select 1: OUT FIFO select
6	–	–	Reserved
5	–	–	Reserved
4	–	–	Reserved
3	–	–	Reserved
2:0	EP	R/W	Endpoint Selects Bits: 0: Endpoint0 1: Endpoint1 2: Endpoint2 3: Endpoint3 4: Endpoint4

- USB endpoint control register (UCON)

The Endpoint selected by the USB endpoint select register (see [Table 124 on page 172](#)) determines the direction and FIFO (IN or OUT) that is controlled by the USB endpoint control register (see [Table 126](#)). The USB endpoint control register is used to control the selected Endpoint and provides some status about that Endpoint.

Table 126. USB endpoint control register (UCON 0F1h, reset value 08h)

Bit 7	Bit 6	Bit 5	Bit 4	Bit 3	Bit 2	Bit 1	Bit 0
–	–	–	–	Enable	STALL	TOGGLE	BSY

Table 127. UCON register bit definition

Bit	Symbol	R/W	Definition
7	–	–	Reserved
6	–	–	Reserved
5	–	–	Reserved
4	–	–	Reserved
3	ENABLE	R/W	Selected FIFO Enable Bit. <i>Note: All FIFOs for each endpoint is enabled after a reset.</i>
2	STALL	R/W	Stall Control Bit When this bit is set, the Endpoint returns a STALL handshake whenever it receives an IN or OUT token.
1	TOGGLE	R	Data Toggle Bit – Endpoint IN Case The state of this bit determines the type of data packet (0=DATA0 or 1=DATA1) that will be sent during the next IN transaction. This bit is managed by the USB SIE. It is only toggled when an ACK is properly received during the IN transaction. In some cases it may be necessary for firmware to clear this bit. In this case, see the Important Notes section at the end of this data sheet. – Endpoint OUT Case The state of this bit indicates the type of data packet PID that the USB SIE expects to receive with the next OUT transaction (0=DATA0, 1=DATA1). If the Data Toggle for the next OUT transaction received is not as expected, the USB SIE assumes the host is retransmitting the last packet. In this case, an ACK is sent but no interrupt is generated since the original transmission of the packet was OK. This bit is managed by the USB SIE. It is only toggled when an OUT packet is properly received. In some cases it may be necessary for firmware to clear this bit. In this case, see the Important Notes section at the end of this data sheet. <i>Important notes:</i> 1. Disabling and enabling the USB SIE using the USBEN bit the UCTL register clears the TOGGLE bit for both directions of all endpoints. 2. Revision A silicon: See the Important Notes section at the end of the data sheet that explains the workaround for clearing this data toggle bit. 3. Revision B silicon: Disabling and Enabling the selected FIFO using the ENABLE bit in this register clears the data toggle bit for the selected endpoint's FIFO.

Table 127. UCON register bit definition (continued)

Bit	Symbol	R/W	Definition
0	BSY	R/W	<p>FIFO Busy Status</p> <ul style="list-style-type: none"> – Endpoint IN Case <p>Once the FIFO has been loaded and armed (USIZE written with the number of bytes to send), the BSY Bit is set and remains set until the SIE has transmitted the data in the FIFO. The CPU should only access the FIFO when BSY = 0.</p> <ul style="list-style-type: none"> – Endpoint OUT Case <p>While the SIE is receiving data and storing it in the FIFO (BSY = 1), it should not be accessed by the CPU. Once the OUT transaction is complete (BSY=0), the CPU may read the contents of the FIFO. The BSY Bit will remain cleared until another OUT transaction is received.</p>

- **USB FIFO valid size (USIZE)**

The Endpoint selected by the USB endpoint select register (see [Table 124 on page 172](#)) determines the direction and FIFO that is controlled by the USB FIFO valid size (see [Table 128](#)). The USB FIFO valid size register indicates the number of bytes loaded into the IN FIFO that the SIE is to send in a Data packet for an Endpoint IN case and indicates the number of bytes received for an Endpoint OUT case.

Table 128. USB FIFO valid size (USIZE 0F2h, reset value 00h)

Bit 7	Bit 6	Bit 5	Bit 4	Bit 3	Bit 2	Bit 1	Bit 0
–	SIZE[6:0]						

Table 129. USIZE register bit definition

Bit	Symbol	R/W	Definition
7	–	–	Reserved
6:0	SIZE	R/W	<ul style="list-style-type: none"> – Endpoint IN Case <p>The CPU writes the USIZE register with the number of bytes it loaded into the IN endpoint FIFO for transmission with the next IN transaction. Once the USIZE register has been written, the FIFO becomes ready for transmission.</p> <ul style="list-style-type: none"> – Endpoint OUT Case <p>The CPU reads the USIZE register to determine how many bytes were received in the data packet during the last OUT transaction. This tells the CPU how many valid bytes to read from the FIFO.</p> <p><i>Note: Since the FIFOs are 64 bytes in length, the maximum value for SIZE is 64 (40h).</i></p>

- USB FIFO base address high and low registers (UBASEH and UBASEL)
 All 10 Endpoint FIFOs share the same 64-byte address range. The 16-bit base address for the FIFOs is specified using the USB base address registers (see [Table 130](#) and [Table 132](#)). The USB endpoint select register (see [Table 124 on page 172](#)) selects the direction and the Endpoint for the FIFO that is accessed when addressing the 64-bytes of XDATA space starting with the base address specified in the base address registers. The base address is a 64-byte segment where the lower 6 bits of the base register are hardwired to '0.'

Important note: The USB FIFO base address must be set to an open 64-byte segment in the XDATA space. Care should be taken to ensure that there is no overlap of addresses between the USB FIFOs and the flash memory, SRAM, csiop registers, and anything else accessed in the XDATA space. While the logic in the PSD module handles overlap of flash memory, SRAM, and the csiop registers with a fixed priority (see [Section 28.1: PSD module functional description on page 192](#)), this is not the case with the USB FIFOs. Unpredictable results as well as potential damage to the device may occur if there is an overlap of addresses.

Table 130. USB FIFO base address high register (UBASEH 0F3h, reset value 00h)

Bit 7	Bit 6	Bit 5	Bit 4	Bit 3	Bit 2	Bit 1	Bit 0
BASEADDR[15:8]							

Table 131. UBASEH register bit definition

Bit	Symbol	R/W	Definition
7:0	BASEADDR [15:8]	R/W	The upper 8 bits of the 16-bit base address for USB FIFOs to be mapped in XDATA space

Table 132. USB FIFO base address low register (UBASEL 0F4h, reset value 00h)

Bit 7	Bit 6	Bit 5	Bit 4	Bit 3	Bit 2	Bit 1	Bit 0
BASEADDR[7:6]		0	0	0	0	0	0

Table 133. UBASEL register bit definition

Bit	Symbol	R/W	Definition
7:6	BASEADDR [7:6]	R/W	Bits 7 and 6 of the 16-bit base address for the USB FIFOs to be mapped in XDATA space
5:0	BASEADDR [5:0]	R	Hardwired '0'

- USB setup command index and value registers (USCI and USCV)
 When a Setup/Data packet is received over the USB, the 8 bytes of data received are stored in a command buffer. The USB setup command index register (see [Table 134](#)) determines which one of the eight bytes in the buffer is read using the USB setup command value register (see [Table 136](#)).

Table 134. USB setup command index register (USCI 0F5h, reset value 00h)

Bit 7	Bit 6	Bit 5	Bit 4	Bit 3	Bit 2	Bit 1	Bit 0
–	–	–	–	–	USCI[2:0]		

Table 135. USCI register bit definition

Bit	Symbol	R/W	Definition
7:3	–	–	Reserved
2:0	USCI[2:0]	R/W	Index to access one of the 8 bytes of USB Setup Command Data received with the last Setup transaction

Table 136. USB setup command value register (USCV 0F6h, reset value 00h)

Bit 7	Bit 6	Bit 5	Bit 4	Bit 3	Bit 2	Bit 1	Bit 0
USCV[7:0]							

Table 137. USCV register bit definition

Bit	Symbol	R/W	Definition
7:0	USCV	R/W	The nth byte of the 8 bytes of USB Setup Command Data received with the last Setup transaction. The nth byte that is read from this register is specified by the index value in the USCI register.

25.5 Typical connection to USB

Connecting the UPSD34xx to the USB is simple and straightforward. *Figure 55* shows a typical self-powered example requiring only three resistors and a USB power detection circuit. The USB power detection circuit detects when the device has been connected to the USB. When V_{BUS} is detected, it switches 3.3 V to the pull-up resistor on the D+ line. Per the USB specification, the pull-up resistor on D+ is required to signal to the upstream USB port when a full speed device has been connected to the bus. The resistors in series in the D+ and D- lines are recommended per the USB specification to reduce transients on the data lines.

Figure 55. Typical self powered example

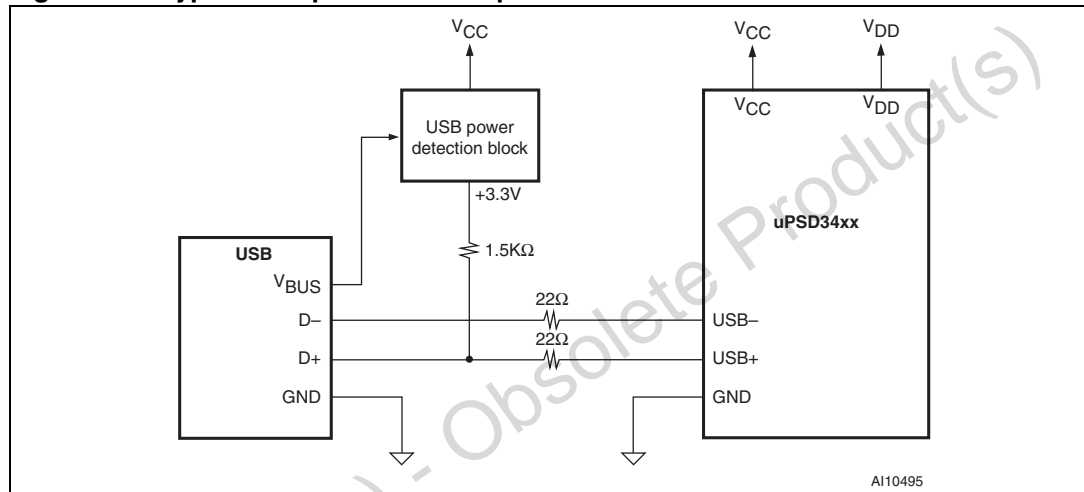

Obsolete Product(s) - Obsolete Product(s)

26 Analog-to-digital convertor (ADC)

The ADC unit in the UPSD34xx is a SAR type ADC with an SAR register, an auto-zero comparator and three internal DACs. The unit has 8 input channels with 10-bit resolution. The A/D converter has its own AV_{REF} input (80-pin package only), which specifies the voltage reference for the A/D operations. The analog to digital converter (A/D) allows conversion of an analog input to a corresponding 10-bit digital value. The A/D module has eight analog inputs (P1.0 through P1.7) to an 8x1 multiplexor. One ADC channel is selected by the bits in the configuration register. The converter generates a 10-bit result via successive approximation. The analog supply voltage is connected to the AV_{REF} input, which powers the resistance ladder in the A/D module.

The A/D module has 3 registers, the control register ACON, the A/D result register ADAT0, and the second A/D result register ADAT1. The ADAT0 register stores Bits 0.. 7 of the converter output, Bits 8.. 9 are stored in Bits 0..1 of the ADAT1 register. The ACON register controls the operation of the A/D converter module. Three of the bits in the ACON register select the analog channel inputs, and the remaining bits control the converter operation.

ADC channel pin input is enabled by setting the corresponding bit in the P1SFS0 and P1SFS1 registers to '1' and the channel select bits in the ACON register.

The ADC reference clock (ADCCLK) is generated from f_{OSC} divided by the divider in the ADCPS register. The ADC operates within a range of 2 to 16MHz, with typical ADCCLK frequency at 8MHz.

The conversion time is 4 μ s typical at 8MHz.

The processing of conversion starts when the Start Bit ADST is set to '1.' After one cycle, it is cleared by hardware. The ADC is monotonic with no missing codes. Measurement is by continuous conversion of the analog input. The ADAT register contains the results of the A/D conversion. When conversion is complete, the result is loaded into the ADAT. The A/D Conversion Status Bit ADSF is set to '1.' The block diagram of the A/D module is shown in [Figure 56](#). The A/D status bit ADSF is set automatically when A/D conversion is completed and cleared when A/D conversion is in process.

In addition, the ADC unit sets the interrupt flag in the ACON register after a conversion is complete (if AINTEN is set to '1'). The ADC interrupts the CPU when the enable bit AINTEN is set.

26.1 Port 1 ADC channel selects

The P1SFS0 and P1SFS1 registers control the selection of the Port 1 pin functions. When the P1SFS0 Bit is '0,' the pin functions as a GPIO. When bits are set to '1,' the pins are configured as alternate functions. A new P1SFS1 register selects which of the alternate functions is enabled. The ADC channel is enabled when the bit in P1SFS1 is set to '1.'

Note: In the 52-pin package, there is no individual AV_{REF} pin because AV_{REF} is combined with AV_{CC} pin.

Figure 56. 10-bit ADC

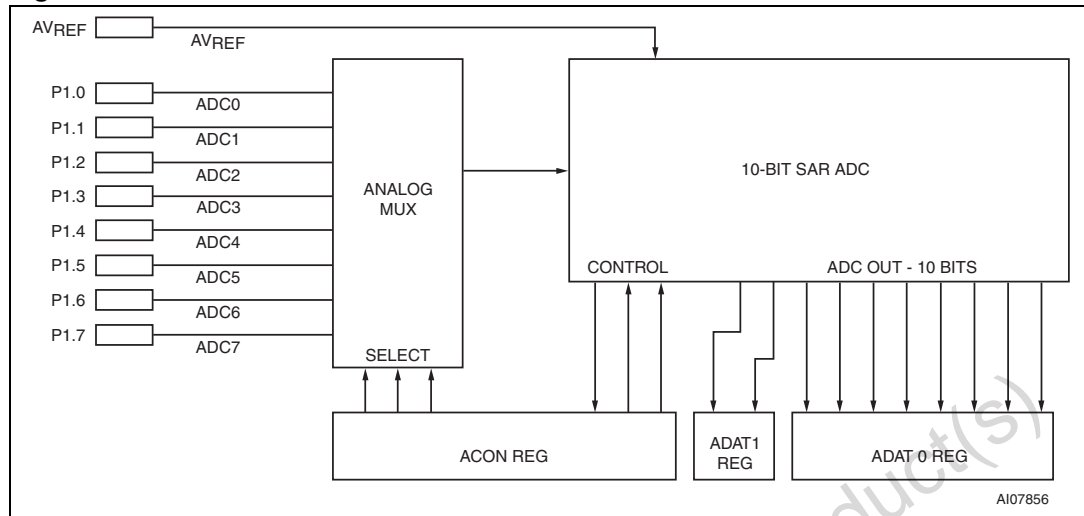

Table 138. ACON register (SFR 97h, reset value 00h)

Bit 7	Bit 6	Bit 5	Bit 4	Bit 3	Bit 2	Bit 1	Bit 0
AINTF	AINTEN	ADEN	ADS2	ADS1	ADS0	ADST	ADSF

Table 139. ACON register bit definition

Bit	Symbol	Function
7	AINTF	ADC Interrupt flag. This bit must be cleared with software. 0 = No interrupt request 1 = The AINTF flag is set when ADSF goes from '0' to '1.' Interrupts CPU when both AINTF and AINTEN are set to '1.'
6	AINTEN	ADC Interrupt Enable 0 = ADC interrupt is disabled 1 = ADC interrupt is enabled
5	ADEN	ADC Enable Bit 0 = ADC shut off and consumes no operating current 1 = Enable ADC. After ADC is enabled, 16ms of calibration is needed before ADST Bit is set.
4.. 2	ADS2.. 0	Analog channel Select 000 Select channel 0 (P1.0) 001 Select channel 0 (P1.1) 010 Select channel 0 (P1.2) 011 Select channel 0 (P1.3) 101 Select channel 0 (P1.5) 110 Select channel 0 (P1.6) 111 Select channel 0 (P1.7)

Table 139. ACON register bit definition (continued)

Bit	Symbol	Function
1	ADST	ADC start bit 0 = Force to zero 1 = Start ADC, then after one cycle, the bit is cleared to '0.'
0	ADSF	ADC Status Bit 0 = ADC conversion is not completed 1 = ADC conversion is completed. The bit can also be cleared with software.

Table 140. ADCPS register details (SFR 94h, Reset Value 00h)

Bit	Symbol	Function
7:4	–	Reserved
3	ADCCE	ADC conversion reference clock enable 0 = ADC reference clock is disabled (default) 1 = ADC reference clock is enabled
2:0	ADCPS[2:0]	ADC reference clock prescaler Only three Prescaler values are allowed: ADCPS[2:0] = 0, for f_{OSC} frequency 16MHz or less. Resulting ADC clock is f_{OSC} . ADCPS[2:0] = 1, for f_{OSC} frequency 32MHz or less. Resulting ADC clock is $f_{OSC}/2$. ADCPS[2:0] = 2, for f_{OSC} frequency 32MHz > 40MHz. Resulting ADC clock is $f_{OSC}/4$.

Table 141. ADAT0 register (SFR 95h, reset value 00h)

Bit	Symbol	Function
7:0	–	Store ADC output, Bit 7 - 0

Table 142. ADAT1 register (SFR 96h, reset value 00h)

Bit	Symbol	Function
7:2	–	Reserved
1..0	–	Store ADC output, Bit 9, 8

27 Programmable counter array (PCA) with PWM

There are two Programmable Counter Array blocks (PCA0 and PCA1) in the UPSD34xx. A PCA block consists of a 16-bit up-counter, which is shared by three TCM (Timer Counter Module). A TCM can be programmed to perform one of the following four functions:

1. Capture Mode: capture counter values by external input signals
2. Timer Mode
3. Toggle Output Mode
4. PWM Mode: fixed frequency (8-bit or 16-bit), programmable frequency (8-bit only)

27.1 PCA block

The 16-bit Up-Counter in the PCA block is a free-running counter (except in PWM Mode with programmable frequency). The Counter has a choice of clock input: from an external pin, Timer 0 Overflow, or PCA Clock.

A PCA block has 3 Timer Counter Modules (TCM) which share the 16-bit Counter output. The TCM can be configured to capture or compare counter value, generate a toggling output, or PWM functions. Except for the PWM function, the other TCM functions can generate an interrupt when an event occurs.

Every TCM is connected to a port pin in Port 4; the TCM pin can be configured as an event input, a PWMs, a Toggle Output, or as External Clock Input. The pins are general I/O pins when not assigned to the TCM.

The TCM operation is configured by Control registers and Capture/Compare registers. [Table 143 on page 182](#) lists the SFR registers in the PCA blocks.

Figure 57. PCA0 block diagram

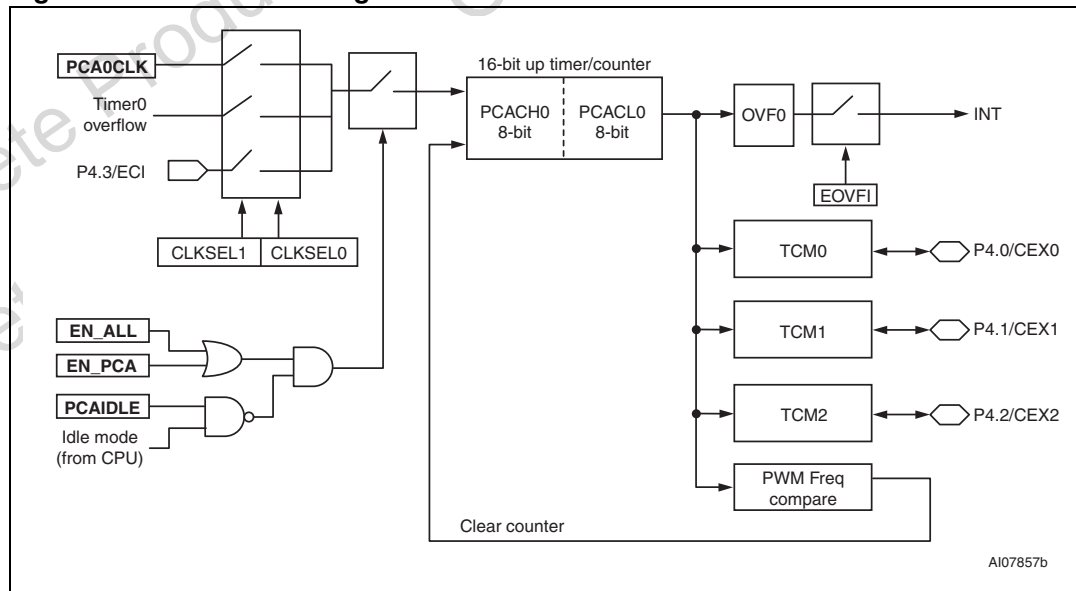

Table 143. PCA0 and PCA1 registers

SFR address		Register name		RW	Register function
PCA0	PCA1	PCA0	PCA1		
A2	BA	PCACL0	PCACL1	RW	The low 8 bits of PCA 16-bit counter.
A3	BB	PCACH0	PCACH1	RW	The high 8 bits of PCA 16-bit counter.
A4	BC	PCACON0	PCACON1	RW	Control register – Enable PCA, Timer Overflow flag , PCA Idle Mode, and Select clock source.
A5	A5	PCASTA	N/A	RW	Status register, Interrupt Status flags – Common for both PCA Block 0 and 1.
A9, AA, AB	BD, BE, BF	TCMMODE0 TCMMODE1 TCMMODE2	TCMMODE3 TCMMODE4 TCMMODE5	RW	TCM Mode – Capture, Compare, and Toggle Enable Interrupts – PWM Mode Select.
AC AD	C1 C2	CAPCOML0 CAPCOMH0	CAPCOML3 CAPCOMH3	RW	Capture/Compare registers of TCM0
AF B1	C3 C4	CAPCOML1 CAPCOMH1	CAPCOML4 CAPCOMH4	RW	Capture/Compare registers of TCM1
B2 B3	C5 C6	CAPCOML2 CAPCOMH2	CAPCOML5 CAPCOMH5	RW	Capture/Compare registers of TCM2
B4	C7	PWMF0	PWMF1	RW	The 8-bit register to program the PWM frequency. This register is used for programmable, 8-bit PWM Mode only.
FB	FC	CCON2	CCON3	RW	Specify the pre-scaler value of PCA0 or PCA1 clock input

27.2 PCA clock selection

- The clock input to the 16-bit up counter in the PCA block is user-programmable. The three clock sources are:
 - PCA Prescaler Clock (PCA0CLK, PCA1CLK)
 - Timer 0 Overflow
 - External Clock, Pin P4.3 or P4.7

The clock source is selected in the configuration register PCACON. The Prescaler output clock PCACLK is the f_{OSC} divided by the divisor which is specified in the CCON2 or CCON3 register. When External Clock is selected, the maximum clock frequency should not exceed $f_{OSC}/4$.

Table 144. CCON2 register bit definition (SFR 0FBh, reset value 10h)

Bit 7	Bit 6	Bit 5	Bit 4	Bit 3	Bit 2	Bit 1	Bit 0
–	–	–	PCA0CE	PCA0PS3	PCA0PS2	PCA0PS1	PCA0PS0

Table 145. CCON2 register bit definition

Bit	Symbol	R/W	Definition
4	PCA0CE	R/W	PCA0 Clock Enable 0 = PCA0CLK is disabled 1 = PCA0CLK is enabled (default)
3:0	PCA0PS [3:0]	R/W	PCA0 Prescaler $f_{PCA0CLK} = f_{OSC} / (2 \wedge PCA0PS[3:0])$ Divisor range: 1, 2, 4, 8, 16... 16384, 32768

Table 146. CCON3 register bit definition (SFR 0FCh, reset value 10h)

Bit 7	Bit 6	Bit 5	Bit 4	Bit 3	Bit 2	Bit 1	Bit 0
–	–	–	PCA1CE	PCA1PS3	PCA1PS2	PCA1PS1	PCA1PS0

Table 147. CCON3 register bit definition

Bit	Symbol	R/W	Definition
4	PCA1CE	R/W	PCA1 Clock Enable 0 = PCA1CLK is disabled 1 = PCA1CLK is enabled (default)
3:0	PCA1PS [3:0]	R/W	PCA1 Prescaler $f_{PCA1CLK} = f_{OSC} / (2 \wedge PCA1PS[3:0])$ Divisor range: 1, 2, 4, 8, 16... 16384, 32768

27.3 Operation of TCM modes

Each of the TCM in a PCA block supports four modes of operation. However, an exception is when the TCM is configured in PWM Mode with programmable frequency. In this mode, all TCM in a PCA block must be configured in the same mode or left to be not used.

27.4 Capture mode

The CAPCOM registers in the TCM are loaded with the counter values when an external pin input changes state. The user can configure the counter value to be loaded by positive edge, negative edge or any transition of the input signal. At loading, the TCM can generate an interrupt if it is enabled.

27.5 Timer mode

The TCM modules can be configured as software timers by enable the comparator. The user writes a value to the CAPCOM registers, which is then compared with the 16-bit counter. If there is a match, an interrupt can be generated to CPU.

27.6 Toggle mode

In this mode, the user writes a value to the TCM's CAPCOM registers and enables the comparator. When there is a match with the Counter output, the output of the TCM pin toggles. This mode is a simple extension of the Timer Mode.

27.7 PWM mode - (x8), fixed frequency

In this mode, one or all the TCM's can be configured to have a fixed frequency PWM output on the port pins. The PWM frequency depends on when the low byte of the Counter overflows (modulo 256). The duty cycle of each TCM module can be specified in the CAPCOMHn register. When the PCA_Counter_L value is equal to or greater than the value in CAPCOMLn, the PWM output is switched to a high state. When the PCA_Counter_L register overflows, the content in CAPCOMHn is loaded to CAPCOMLn and a new PWM pulse starts.

Figure 58. Timer mode

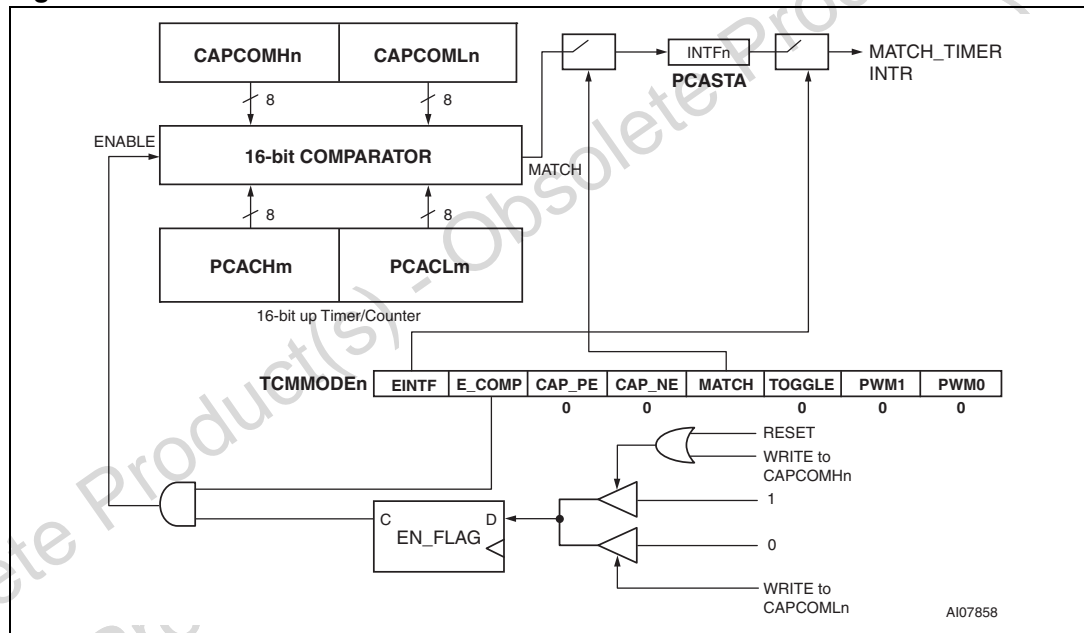

1. m = 0: n = 0, 1, or 2
 m = 1: n = 3, 4, or 5

Figure 59. PWM mode - (x8), fixed frequency

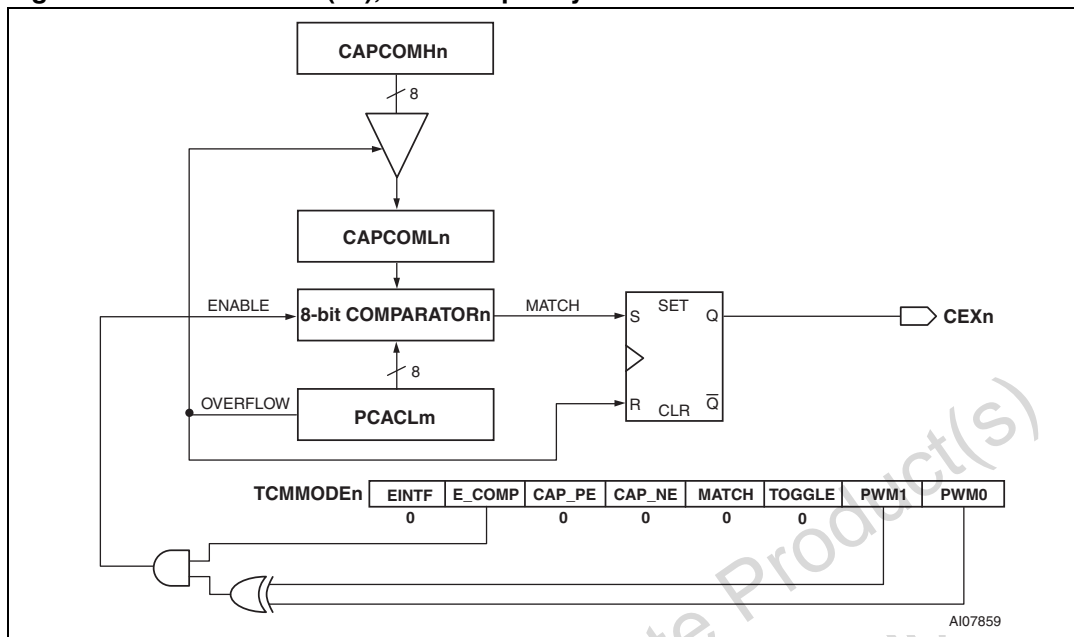

- 1. m = 0: n = 0, 1, or 2
 m = 1: n = 3, 4, or 5

27.8 PWM mode - (x8), programmable frequency

In this mode, the PWM frequency is not determined by the overflow of the low byte of the Counter. Instead, the frequency is determined by the PWMFm register. The user can load a value in the PWMFm register, which is then compared to the low byte of the Counter. If there is a match, the Counter is cleared and the Load registers (PWMFm, CAPCOMHn) are re-loaded for the next PWM pulse. There is only one PWMFm register which serves all 3 TCM in a PCA block.

If one of the TCM modules is operating in this mode, the other modules in the PCA must be configured to the same mode or left not to be used. The duty cycle of the PWM can be specified in the CAPCOMHn register as in the PWM with fixed frequency mode. Different TCM modules can have their own duty cycle.

Note: The value in the frequency register (PWMFm) must be larger than the duty cycle register (CAPCOM).

Figure 60. PWM mode - (x8) programmable frequency

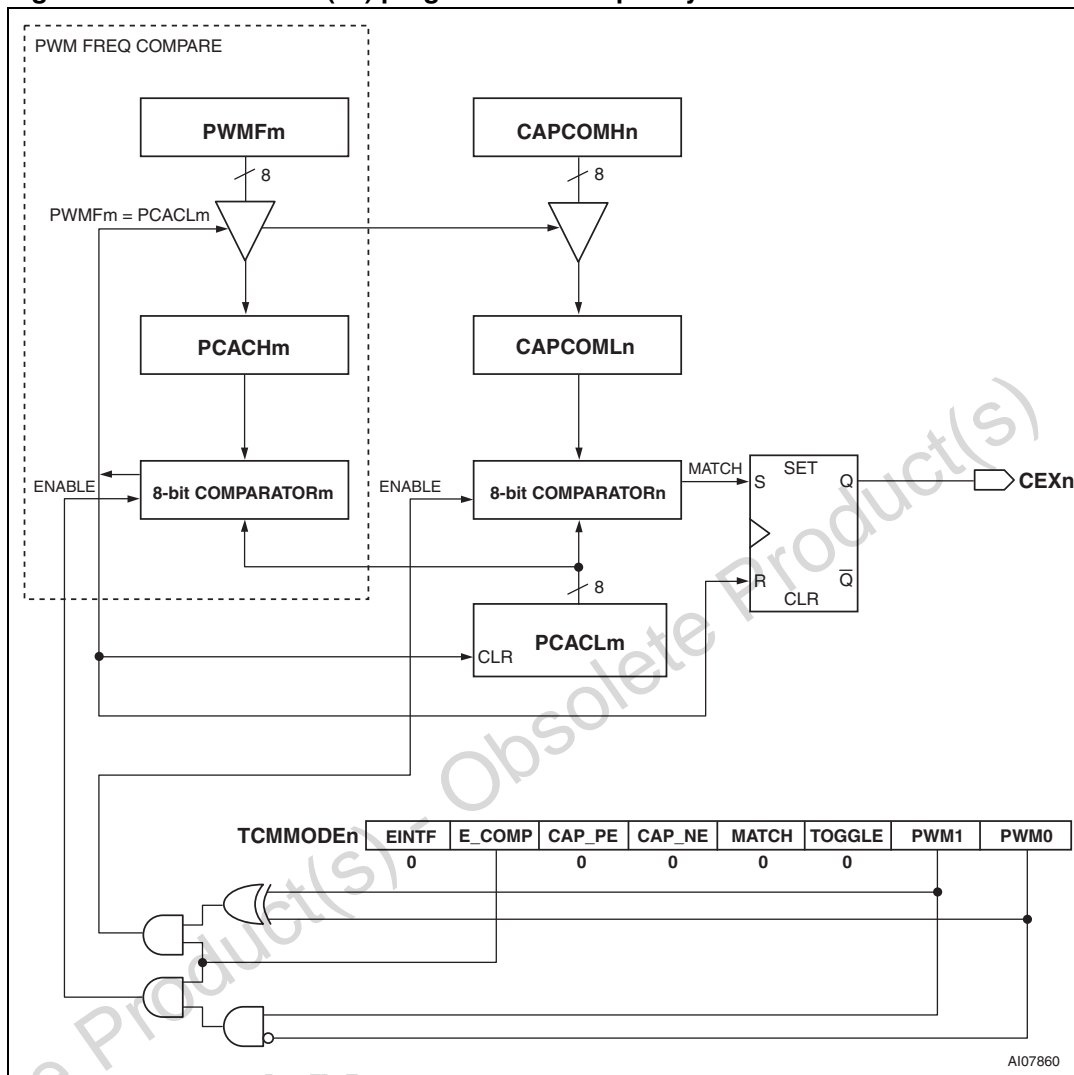

- 1. m = 0: n = 0, 1, or 2
m = 1: n = 3, 4, or 5

27.9 PWM mode - fixed frequency, 16-bit

The operation of the 16-bit PWM is the same as the 8-bit PWM with fixed frequency. In this mode, one or all the TCM can be configured to have a fixed frequency PWM output on the port pins. The PWM frequency is depending on the clock input frequency to the 16-bit Counter. The duty cycle of each TCM module can be specified in the CAPCOMHn and CAPCOMLn registers. When the 16-bit PCA_Counter is equal or greater than the values in registers CAPCOMHn and CAPCOMLn, the PWM output is switched to a high state. When the PCA_Counter overflows, CEXn is asserted low.

27.10 PWM mode - fixed frequency, 10-bit

The 10-bit PWM logic requires that all 3 TCMs in PCA0 or PCA1 operate in the same 10-bit PWM mode. The 10-bit PWM operates in a similar manner as the 16-bit PWM, except the PCACHm and PCACLm counters are reconfigured as 10-bit counters. The CAPCOMHn and CAPCOMLm registers become 10-bit registers.

PWM duty cycle of each TCM module can be specified in the 10-bit CAPCOMHn and CAPCOMLm registers. When the 10-bit PCA counter is equal or greater than the values in the 10-bit registers CAPCOMHn and CAPCOMLm, the PWM output switches to a high state. When the 10-bit PCA counter overflows, the PWM pin is switched to a logic low and starts the next PWM pulse.

The most-significant 6 bits in the PCACHm counter and CAPCOMH register are “Don’t cares” and have no effect on the PWM generation.

27.11 Writing to capture/compare registers

When writing a 16-bit value to the PCA Capture/Compare registers, the low byte should always be written first. Writing to CAPCOMLm clears the E_COMP Bit to '0'; writing to CAPCOMHm sets E_COMP to '1' the largest duty cycle is 100% (CAPCOMHm CAPCOMLm = 0000h), and the smallest duty cycle is 0.0015% (CAPCOMHm CAPCOMLm = FFFFh). A 0% duty cycle may be generated by clearing the E_COMP Bit to '0'.

27.12 Control register bit definition

Each PCA has its own PCA_CONFIGn, and each module within the PCA block has its own TCM_Mode register which defines the operation of that module (see [Table 148 on page 187](#) through [Table 150 on page 188](#)). There is one PCA_STATUS register that covers both PCA0 and PCA1 (see [Table 152 on page 188](#)).

Table 148. PCA0 control register PCACON0 (SFR 0A4h, reset value 00h)

Bit 7	Bit 6	Bit 5	Bit 4	Bit 3	Bit 2	Bit 1	Bit 0
EN-ALL	EN_PCA	EOVFI	PCAIDLE	–	–	CLK_SEL[1:0]	

Table 149. PCA0 register bit definition

Bit	Symbol	Function
7	EN-ALL	0 = No impact on TCM modules 1 = Enable both PCA counters simultaneously (override the EN_PCA Bits) This bit is to start the two 16-bit counters in the PCA. For customers who want 5 PWM, for example, this bit can start all of the PWM outputs.
6	EN_PCA	0 = PCA counter is disabled 1 = PCA counter is enabled EN_PCA Counter Run Control Bit. Set with software to turn the PCA counter on. Must be cleared with software to turn the PCA counter off.
5	EOVFI	1 = Enable Counter Overflow Interrupt if overflow flag (OVF) is set
4	PCAIDLE	0 = PCA operates when CPU is in Idle Mode 1 = PCA stops running when CPU is in Idle Mode

Table 149. PCA0 register bit definition (continued)

Bit	Symbol	Function
3	–	Reserved
2	10B_PWM	0 = Select 16-bit PWM 1 = Select 10-bit PWM
1-0	CLK_SEL [1:0]	00 Select Prescaler clock as Counter clock 01 Select Timer 0 Overflow 10 Select External Clock pin (P4.3 for PCA0) (MAX clock rate = $f_{OSC}/4$)

Table 150. PCA1 control register PCACON1 (SFR 0BCh, reset value 00h)

Bit 7	Bit 6	Bit 5	Bit 4	Bit 3	Bit 2	Bit 1	Bit 0
–	EN_PCA	EOVFI	PCAIIDLE	–	–	CLK_SEL[1:0]	

Table 151. PCA1 register bit definition

Bit	Symbol	Function
6	EN_PCA	0 = PCA counter is disabled 1 = PCA counter is enabled EN_PCA Counter Run Control Bit. Set with software to turn the PCA counter on. Must be cleared with software to turn the PCA counter off.
5	EOVFI	1 = Enable Counter Overflow Interrupt if overflow flag (OVF) is set
4	PCAIIDLE	0 = PCA operates when CPU is in Idle Mode 1 = PCA stops running when CPU is in Idle Mode
3	–	Reserved
2	10B_PWM	0 = Select 16-bit PWM 1 = Select 10-bit PWM
1-0	CLK_SEL [1:0]	00 Select Prescaler clock as Counter clock 01 Select Timer 0 Overflow 10 Select External Clock pin (P4.7 for PCA1) (MAX clock rate = $f_{OSC}/4$)

Table 152. PCA status register PCASTA (SFR 0A5h, reset value 00h)

Bit 7	Bit 6	Bit 5	Bit 4	Bit 3	Bit 2	Bit 1	Bit 0
OVF1	INTF5	INTF4	INTF3	OVF0	INTF2	INTF1	INTF0

Table 153. PCASTA register bit definition

Bit	Symbol	Function
7	OVF1	PCA1 Counter OverFlow flag Set by hardware when the counter rolls over. OVF1 flags an interrupt if Bit EOVFI in PCACON1 is set. OVF1 may be set with either hardware or software but can only be cleared with software.
6	INTF5	TCM5 Interrupt flag Set by hardware when a match or capture event occurs. Must be clear with software.

Table 153. PCASTA register bit definition (continued)

Bit	Symbol	Function
5	INTF4	TCM4 Interrupt flag Set by hardware when a match or capture event occurs. Must be clear with software.
4	INTF3	TCM3 Interrupt flag Set by hardware when a match or capture event occurs. Must be clear with software.
3	OVF0	PCA0 Counter OverFlow flag Set by hardware when the counter rolls over. OVF0 flags an interrupt if Bit EOVI in PCAON0 is set. OVF1 may be set with either hardware or software but can only be cleared with software.
2	INTF2	TCM2 Interrupt flag Set by hardware when a match or capture event occurs. Must be clear with software.
1	INTF1	TCM1 Interrupt flag Set by hardware when a match or capture event occurs. Must be clear with software.
0	INTF0	TCM0 Interrupt flag Set by hardware when a match or capture event occurs. Must be clear with software.

27.13 TCM interrupts

There are 8 TCM interrupts: 6 match or capture interrupts and two counter overflow interrupts. The 8 interrupts are “ORed” as one PCA interrupt to the CPU.

By the nature of PCA application, it is unlikely that many of the interrupts occur simultaneously. If they do, the CPU has to read the interrupt flags and determine which one to serve. The software has to clear the interrupt flag in the status register after serving the interrupt.

Table 154. TCMMODE0 - TCMMODE5 (6 registers, reset value 00h)

Bit 7	Bit 6	Bit 5	Bit 4	Bit 3	Bit 2	Bit 1	Bit 0
EINTF	E_COMP	CAP_PE	CAP_NE	MATCH	TOGGLE	PWM[1:0]	

Table 155. TCMMODE0 - TCMMODE5 register bit definition

Bit	Symbol	Function
7	EINTF	1 - Enable the interrupt flags (INTF) in the status register to generate an interrupt.
6	E_COMP	1 - Enable the comparator when set
5	CAP_PE	1 - Enable Capture Mode, a positive edge on the CEXn pin.
4	CAP_NE	1 - Enable Capture Mode, a negative edge on the CEXn pin.
3	MATCH	1 - A match from the comparator sets the INTF bits in the status register.

Table 155. TCMODE0 - TCMODE5 register bit definition (continued)

Bit	Symbol	Function
2	TOGGLE	1 - A match on the comparator results in a toggling output on CEXn pin.
1-0	PWM[1:0]	01 Enable PWM Mode (x8), fixed frequency. Enable the CEXn pin as a PWM output. 10 Enable PWM Mode (x8) with programmable frequency. Enable the CEXn pin as a PWM output. 11 Enable PWM Mode (x10 or x16), fixed frequency. Enable the CEXn pin as a PWM output.

Table 156. TCMODE register configurations

EINTF	E_COMP	CAP_PE	CAP_NE	MATCH	TOGGLE	PWM1	PWM0	TCM FUNCTION
0	0	0	0	0	0	0	0	No operation (reset value)
0	1	0	0	0	0	0	1	8-bit PWM, fixed frequency
0	1	0	0	0	0	1	0	8-bit PWM, programmable frequency
0	1	0	0	0	0	1	1	10-bit or 16-bit PMW, fixed frequency ⁽¹⁾
X	1	0	0	1	1	0	0	16-bit toggle
X	1	0	0	1	0	0	0	16-bit Software Timer
X	X	0	1	0	0	0	0	16-bit capture, negative trigger
X	X	1	0	0	0	0	0	16-bit capture, positive trigger
X	X	1	1	0	0	0	0	16-bit capture, transition trigger

1. 10-bit PWM mode requires the 10B_PWM Bit in the PCACON register set to '1.'

28 PSD module

The PSD module is stacked with the MCU module to form the UPSD34xx, see [Section 3: Hardware description on page 28](#). Details of the PSD module are shown in [Figure 61](#). The two separate modules interface with each other at the 8032 Address, Data, and Control interface blocks in [Figure 61](#).

Figure 61. PSD module block diagram

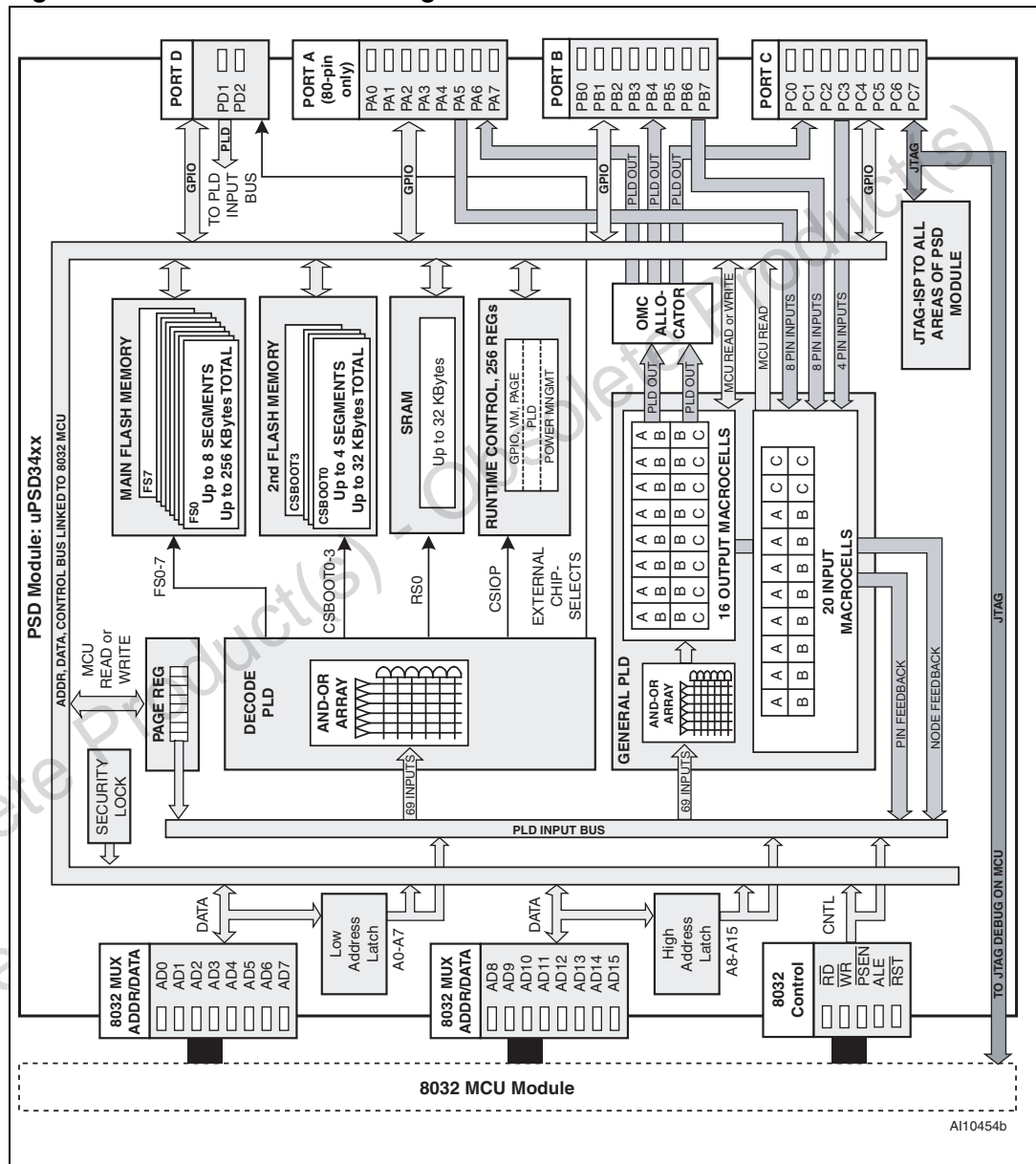

28.1 PSD module functional description

Major functional blocks are shown in [Figure 61 on page 191](#). The next sections describe each major block.

28.1.1 8032 address/data/control interface

These signals attach directly to the MCU module to implement a 16-bit multiplexed 8051-style bus between the two stacked die. The MCU instruction prefetch and branch cache logic resides on the MCU module, leaving a modified 8051-style memory interface on the PSD module.

The active-low reset signal originating from the MCU module goes to the PSD module reset input ($\overline{\text{RST}}$). This reset signal can then be routed as an external output from the UPSD34xx to the system PC board, if needed, through any one of the PLD output pins as active-high or active-low logic by specifying logic equations in PSDsoft Express.

The 8032 address and data busses are routed throughout the PSD module as shown in [Figure 61](#) connecting many elements on the PSD module to the 8032 MCU. The 8032 bus is not only connected to the memories, but also to the General PLD, making it possible for the 8032 to directly read and write individual logic macrocells inside the General PLD.

28.1.2 Dual Flash memories and IAP

UPSD34xx devices contain two independent Flash memory arrays. This means that the 8032 can read instructions from one Flash memory array while erasing or writing the other Flash memory array. Concurrent operation like this enables robust remote updates of firmware, also known as In-Application Programming (IAP). IAP can occur using any UPSD34xx interface (e.g., UART, I2C, SPI). Concurrent memory operation also enables the designer to emulate EEPROM memory within either of the two Flash memory arrays for small data sets that have frequent updates.

The 8032 can erase Flash memories by individual sectors or it can erase an entire Flash memory array at one time. Each sector in either Flash memory may be individually write protected, blocking any WRITES from the 8032 (good for boot and start-up code protection). The Flash memories automatically go to standby between 8032 READ or WRITE accesses to conserve power. Minimum erase cycles is 100K and minimum data retention is 15 years. Flash memory, as well as the entire PSD module may be programmed with the JTAG In-System Programming (ISP) interface with no 8032 involvement, good for manufacturing and lab development.

28.1.3 Main Flash memory

The Main Flash memory is divided into equal sized sectors that are individually selectable by the Decode PLD output signals, named FSx, one signal for each Main Flash memory sector. Each Flash sector can be located at any address within 8032 program address space (accessed with $\overline{\text{PSEN}}$) or data address space, also known as 8032 XDATA space (accessed with $\overline{\text{RD}}$ or $\overline{\text{WR}}$), as defined with the software development tool, PSDsoft Express. The user only has to specify an address range for each segment and specify if Main Flash memory will reside in 8032 data or program address space, and then $\overline{\text{PSEN}}$, $\overline{\text{RD}}$, or $\overline{\text{WR}}$ are automatically activated for the specified range. 8032 firmware is easily programmed into Main Flash memory using PSDsoft Express or other software tools. See [Table 157 on page 193](#) for Main Flash sector sizes on the various UPSD34xx devices.

28.1.4 Secondary Flash memory

The smaller Secondary Flash memory is also divided into equal sized sectors that are individually selectable by the Decode PLD signals, named CSBOOTx, one signal for each Secondary Flash memory sector. Each sector can be located at any address within 8032 program address space (accessed with \overline{PSEN}) or XDATA space (accessed with \overline{RD} or \overline{WR}) as defined with PSDsoft Express. The user only has to specify an address range for each segment, and specify if Secondary Flash memory will reside in 8032 data or program address space, and then \overline{PSEN} , \overline{RD} , or \overline{WR} are automatically activated for the specified range. 8032 firmware is easily programmed into Secondary Flash memory using PSDsoft Express and others. See [Table 157 on page 193](#) for Secondary Flash sector sizes.

28.1.5 SRAM

The SRAM is selected by a single signal, named RS0, from the Decode PLD. SRAM may be located at any address within 8032 XDATA space (accessed with \overline{RD} or \overline{WR}). These choices are specified using PSDSoft Express, where the user specifies an SRAM address range. See [Table 157 on page 193](#) for SRAM sizes.

Table 157. UPSD34xx memory configuration

Device	Main Flash memory			Secondary Flash memory			SRAM
	Total Flash size (bytes)	Individual sector size (bytes)	Number of sectors (Sector Select signal)	Total Flash size (bytes)	Individual sector size (bytes)	Number of sectors (Sector Select signal)	SRAM size (bytes)
UPSD3422	64 KB	16 KB	4 (FS0-3)	32 KB	8 KB	4 (CSBOOT0-3)	4 KB
UPSD3433	128 KB	16 KB	8 (FS0-7)	32 KB	8 KB	4 (CSBOOT0-3)	8 KB
UPSD3434	256 KB	32 KB	8 (FS0-7)	32 KB	8 KB	4 (CSBOOT0-3)	8 KB
UPSD3454	256 KB	32 KB	8 (FS0-7)	32 KB	8 KB	4 (CSBOOT0-3)	32 KB

28.1.6 Runtime control registers, csiop

A block of 256 bytes is decoded inside the PSD module for module control and status (see [Table 162 on page 205](#)). The base address of these 256 locations is referred to in this data sheet as csiop (Chip Select I/O Port), and is selected by the Decode PLD output signal, CSIOP. The csiop registers are always viewed by the 8032 as XDATA, and are accessed with \overline{RD} and \overline{WR} signals. The address range of csiop is specified using PSDsoft Express where the user only has to specify an address range of 256 bytes, and then the \overline{RD} or \overline{WR} signals are automatically activated for the specified range. Individual registers within this block are accessed with an offset from the specified csiop base address. 39 registers are used out of the 256 locations to control the output state of I/O pins, to read I/O pins, to set the memory page, to control 8032 program and data address space, to control power management, to READ/WRITE macrocells inside the General PLD, and other functions during runtime. Unused locations within csiop are reserved and should not be accessed.

28.1.7 Memory page register

8032 MCU architecture has an inherent size limit of 64K bytes in either program address space or XDATA space. Some UPSD34xx devices have much more memory than 64K, so special logic such as this page register is needed to access the extra memory. This 8-bit

page register (Figure 62) can be loaded and read by the 8032 at runtime as one of the csiop registers. Page register outputs feed directly into both PLDs creating extended address signals used to “page” memory beyond the 64K byte limit (program space or XDATA). Most 8051 compilers directly support memory paging, also known as memory banking. If memory paging is not needed, or if not all eight page register bits are needed for memory paging, the remaining bits may be used in the General PLD for general logic. Page register outputs are cleared to logic '0' at reset and power-up.

28.1.8 Programmable logic (PLDs)

The UPSD34xx contains two PLDs (Figure 73 on page 221) that may optionally run in Turbo or Non-Turbo mode. PLDs operate faster (less propagation delay) while in Turbo mode but consume more power than in Non-Turbo mode. Non-Turbo mode allows the PLDs to go to standby automatically when no PLD inputs are changing to conserve power.

The logic configuration (from equations) of both PLDs is stored with non-volatile Flash technology and the logic is active upon power-up. PLDs may NOT be programmed by the 8032, PLD programming only occurs through the JTAG interface.

Figure 62. Memory page register

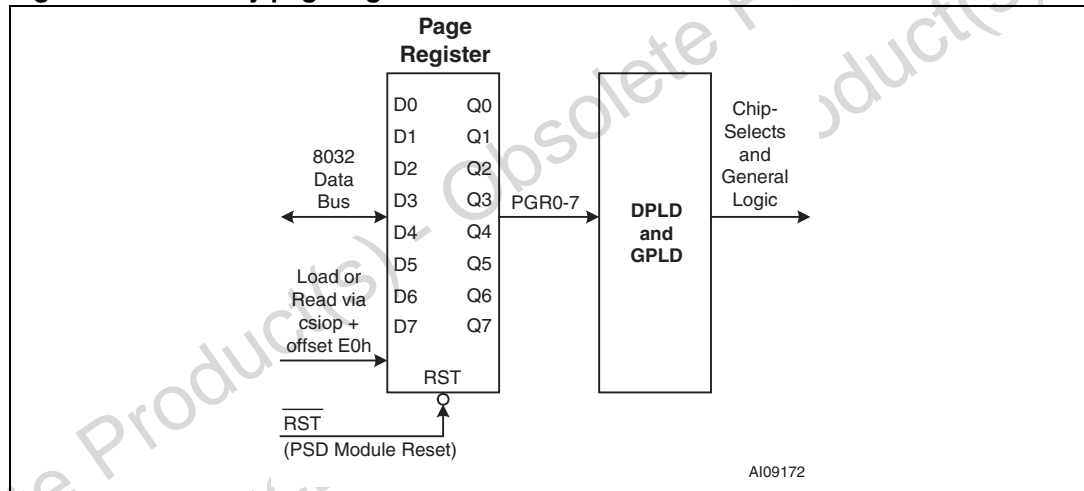

28.1.9 PLD #1, decode PLD (DPLD)

This programmable logic implements memory mapping and is used to select one of the individual Main Flash memory segments, one of individual Secondary Flash memory segments, the SRAM, or the group of csiop registers when the 8032 presents an address to DPLD inputs (see Figure 74 on page 223). The DPLD can also optionally drive external chip select signals on Port D pins. The DPLD also optionally produces two select signals (PSEL0 and PSEL1) used to enable a special data bus repeater function on Port A, referred to as Peripheral I/O Mode. There are 69 DPLD input signals which include: 8032 address and control signals, page register outputs, PSD module Port pin inputs, and GPLD logic feedback.

28.1.10 PLD #2, general PLD (GPLD)

This programmable logic is used to create both combinatorial and sequential general purpose logic (see Figure 75 on page 224). The GPLD contains 16 Output Macrocells (OMCs) and 20 Input Macrocells (IMCs). Output Macrocell registers are unique in that they

have direct connection to the 8032 data bus allowing them to be loaded and read directly by the 8032 at runtime through OMC registers in csiop. This direct access is good for making small peripheral devices (shifters, counters, state machines, etc.) that are accessed directly by the 8032 with little overhead. There are 69 GPLD inputs which include: 8032 address and control signals, page register outputs, PSD module Port pin inputs, and GPLD feedback.

28.1.11 OMCs

There are two banks of eight OMCs inside the GPLD, MCELLAB, and MCELLBC, totalling 16 OMCs all together. Each individual OMC is a base logic element consisting of a flip-flop and some AND-OR logic ([Figure 76 on page 226](#)). The general structure of the GPLD with OMCs is similar in nature to a 22V10 PLD device with the familiar sum-of-products (AND-OR) construct. True and complement versions of 69 input signals are available to the inputs of a large AND-OR array. AND-OR array outputs feed into an OR gate within each OMC, creating up to 10 product-terms for each OMC. Logic output of the OR gate can be passed on as combinatorial logic or combined with a flip-flop within in each OMC to realize sequential logic. OMC outputs can be used as a buried nodes driving internal feedback to the AND-OR array, or OMC outputs can be routed to external pins on Ports A, B, or C through the OMC Allocator.

28.1.12 OMC allocator

The OMC allocator ([Figure 77 on page 227](#)) will route eight of the OMCs from MCELLAB to pins on either Port A or Port B, and will route eight of the OMCs from MCELLBC to pins on either Port B or Port C, based on what is specified in PSDsoft Express.

28.1.13 IMCs

Inputs from pins on Ports A, B, and C are routed to IMCs for conditioning (clocking or latching) as they enter the chip, which is good for sampling and debouncing inputs. Alternatively, IMCs can pass port input signals directly to PLD inputs without clocking or latching ([Figure 78 on page 230](#)). The 8032 may read the IMCs asynchronously at any time through IMC registers in csiop.

Note: The JTAG signals TDO, TDI, TCK, and TMS on Port C do not route through IMCs, but go directly to JTAG logic.

28.1.14 I/O ports

For 80-pin UPSD34xx devices, the PSD module has 22 individually configurable I/O pins distributed over four ports (these I/O are in addition to I/O on MCU module). For 52-pin UPSD34xx devices, the PSD module has 13 individually configurable I/O pins distributed over three ports. See [Figure 84 on page 243](#) for I/O port pin availability on these two packages.

I/O port pins on the PSD module (Ports A, B, C, and D) are completely separate from the port pins on the MCU module (Ports 1, 3, and 4). They even have different electrical characteristics. I/O port pins on the PSD module are accessed by csiop registers, or they are controlled by PLD equations. Conversely, I/O Port pins on the MCU module are controlled by the 8032 SFR registers.

Table 158. General I/O pins on PSD module

Pkg	Port A	Port B	Port C	Port D	Total
52-pin	0	8	4	1	13
80-pin	8	8	4	2	22

Note: Four pins on Port C are dedicated to JTAG, leaving four pins for general I/O.

Each I/O pin on the PSD module can be individually configured for different functions on a pin-by-pin basis ([Figure 79 on page 232](#)). Following are the available functions on PSD module I/O pins.

- **MCU I/O:** 8032 controls the output state of each port pin or it reads input state of each port pin, by accessing csiop registers at run-time. The direction (in or out) of each pin is also controlled by csiop registers at run-time.
- **PLD I/O:** PSDsoft Express logic equations and pin configuration selections determine if pins are connected to OMC outputs or IMC inputs. This is a static and non-volatile configuration. Port pins connected to PLD outputs can no longer be driven by the 8032 using MCU I/O output mode.
- **Latched MCU Address Output:** Port A or Port B can output de-multiplexed 8032 address signals A0 - A7 on a pin-by-pin basis as specified in csiop registers at run-time. In addition, Port B can also be configured to output de-multiplexed A8-A15 in PSDsoft Express.
- **Data Bus Repeater:** Port A can bidirectionally buffer the 8032 data bus (de-multiplexed) for a specified address range in PSDsoft Express. This is referred to as **Peripheral I/O Mode** in this document.
- **Open Drain Outputs:** Some port pins can function as open-drain as specified in csiop registers at run-time.
- Pins on Port D can be used for **external chip-select** outputs originating from the DPLD, without consuming OMC resources within the GPLD.

28.1.15 JTAG port

In-System Programming (ISP) can be performed through the JTAG signals on Port C. This serial interface allows programming of the entire PSD module device or subsections of the PSD module (for example, only Flash memory but not the PLDs) without the participation of the 8032. A blank UPSD34xx device soldered to a circuit board can be completely programmed in 10 to 25 seconds. The four basic JTAG signals on Port C; TMS, TCK, TDI, and TDO form the IEEE-1149.1 interface. The PSD module does not implement the IEEE-1149.1 Boundary Scan functions, but uses the JTAG interface for ISP and 8032 debug. The PSD module can reside in a standard JTAG chain with other JTAG devices and it will remain in BYPASS mode when other devices perform JTAG functions.

ISP programming time can be reduced as much as 30% by using two optional JTAG signals on Port C, TSTAT and $\overline{\text{TERR}}$, in addition to TMS, TCK, TDI and TDO, and this is referred to as "6-pin JTAG". The FlashLINK JTAG programming cable is available from STMicroelectronics and PSDsoft Express software is available at no charge from www.st.com/psm. More JTAG ISP information maybe found in [Section 28.6.1: JTAG ISP and JTAG debug on page 257](#).

The MCU module is also included in the JTAG chain within the UPSD34xx device for 8032 debugging and emulation. While debugging, the PSD module is in BYPASS mode. Conversely, during ISP, the MCU module is in BYPASS mode.

28.1.16 Power management

The PSD module has bits in csiop registers that are configured at run-time by the 8032 to reduce power consumption of the GPLD. The Turbo Bit in the PMMR0 register can be set to logic '1' and both PLDs will go to Non-Turbo mode, meaning it will latch its outputs and go to sleep until the next transition on its inputs. There is a slight penalty in PLD performance (longer propagation delay), but significant power savings are realized. Going to Non-Turbo mode may require an additional wait state in the 8032 SFR, BUSCON, because memory decode signals are also delayed. The default state of the Turbo Bit is logic '0,' meaning by default, the GPLD is in fast Turbo mode until the user turns off Turbo mode.

Additionally, bits in csiop registers PMMR0 and PMMR2 can be set by the 8032 to selectively block signals from entering both PLDs which further reduces power consumption. There is also an Automatic Power Down counter that detects lack of 8032 activity and reduces power consumption on the PSD module to its lowest level (see [Section 28.1.16: Power management on page 197](#)).

28.1.17 Security and NVM sector protection

A programmable security bit in the PSD module protects its contents from unauthorized viewing and copying. The security bit is specified in PSDsoft Express and programmed into the UPSD34xx with JTAG. Once set, the security bit will block access of JTAG programming equipment to the PSD module Flash memory and PLD configuration, and also blocks JTAG debugging access to the MCU module. The only way to defeat the security bit is to erase the entire PSD module using JTAG (the erase command is the only JTAG command allowed after the security bit has been set), after which the device is blank and may be used again.

Additionally and independently, the contents of each individual Flash memory sector can be write protected (sector protection) by configuration with PSDsoft Express. This is typically used to protect 8032 boot code from being corrupted by inadvertent WRITES to Flash memory from the 8032.

Status of sector protection bits may be read (but not written) using two registers in csiop space.

28.2 Memory mapping

There many different ways to place (or map) the address range of PSD module memory and I/O depending on system requirements. The DPLD provides complete mapping flexibility. [Figure 63](#) shows one possible system memory map. In this example, 128 Kbytes of Main Flash memory for a UPSD3433 device is in 8032 program address space, and 32 Kbytes of Secondary Flash memory, the SRAM, and csiop registers are all in 8032 XDATA space.

In [Figure 63](#), the nomenclature fs0..fs7 are designators for the individual sectors of Main Flash memory, 16 Kbytes each. CSBOOT0..CSBOOT3 are designators for the individual Secondary Flash memory segments, 8 Kbytes each. rs0 is the designator for SRAM, and csiop designates the PSD module control register set.

The designer may easily specify memory mapping in a point-and-click software environment using PSDsoft Express, creating a non-volatile configuration when the DPLD is programmed using JTAG.

28.2.1 8032 program address space

In the example of [Figure 63](#), six sectors of Main Flash memory (fs2.. fs7) are paged across three memory pages in the upper half of program address space, and the remaining two sectors of Main Flash memory (fs0, fs1) reside in the lower half of program address space, and these two sectors are independent of paging (they reside in “common” program address space). This paged memory example is quite common and supported by many 8051 software compilers.

28.2.2 8032 data address space (XDATA)

Four sectors of Secondary Flash memory reside in the upper half of 8032 XDATA space in the example of [Figure 63](#). SRAM and csiop registers are in the lower half of XDATA space. The 8032 SFR registers and local SRAM inside the 8032 MCU module do not reside in XDATA space, so it is OK to place PSD module SRAM or csiop registers at an address that overlaps the address of internal 8032 MCU module SRAM and registers.

Figure 63. Typical system memory map

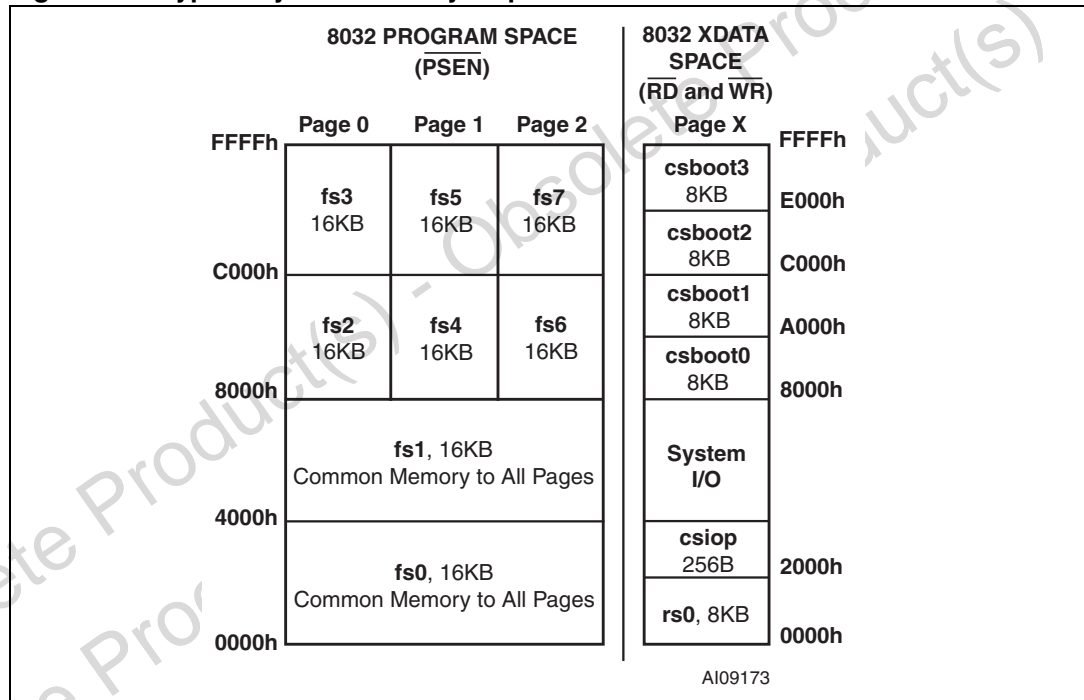

28.2.3 Specifying the memory map with PSDsoft express

The memory map example shown in [Figure 63 on page 198](#) is implemented using PSDsoft Express in a point-and-click environment. PSDsoft Express will automatically generate Hardware Definition Language (HDL) statements of the ABEL language for the DPLD, such as those shown in [Table 159](#).

Specifying these equations using PSDsoft Express is very simple. For example, [Figure 64](#), page 84 shows how to specify the chip-select equation for the 16 Kbyte Flash memory segment, fs4. Notice fs4 is on memory page 1. This specification process is repeated for all other Flash memory segments, the SRAM, the csiop register block, and any external chip select signals that may be needed.

Table 159. HDL statement example generated from PSDsoft express for memory map

```

rs0      = ((address ≥ ^h0000) & (address ≤ ^h1FFF));
csiop    = ((address ≥ ^h2000) & (address ≤ ^h20FF));
fs0      = ((address ≥ ^h0000) & (address ≤ ^h3FFF));
fs1      = ((address ≥ ^h4000) & (address ≤ ^h7FFF));
fs2      = ((page == 0)          & (address ≥ ^h8000) & (address ≤ ^hBFFF));
fs3      = ((page == 0)          & (address ≥ ^hC000) & (address ≤ ^hFFFF));
fs4      = ((page == 1)          & (address ≥ ^h8000) & (address ≤ ^hBFFF));
fs5      = ((page == 1)          & (address ≥ ^hC000) & (address ≤ ^hFFFF));
fs6      = ((page == 2)          & (address ≥ ^h8000) & (address ≤ ^hBFFF));
fs7      = ((page == 2)          & (address ≥ ^hC000) & (address ≤ ^hFFFF));
csboot0  = ((address ≥ ^h8000) & (address ≤ ^h9FFF));
csboot1  = ((address ≥ ^hA000) & (address ≤ ^hBFFF));
csboot2  = ((address ≥ ^hC000) & (address ≤ ^hDFFF));
csboot3  = ((address ≥ ^hE000) & (address ≤ ^hFFFF));
    
```

Figure 64. PSDsoft express memory mapping

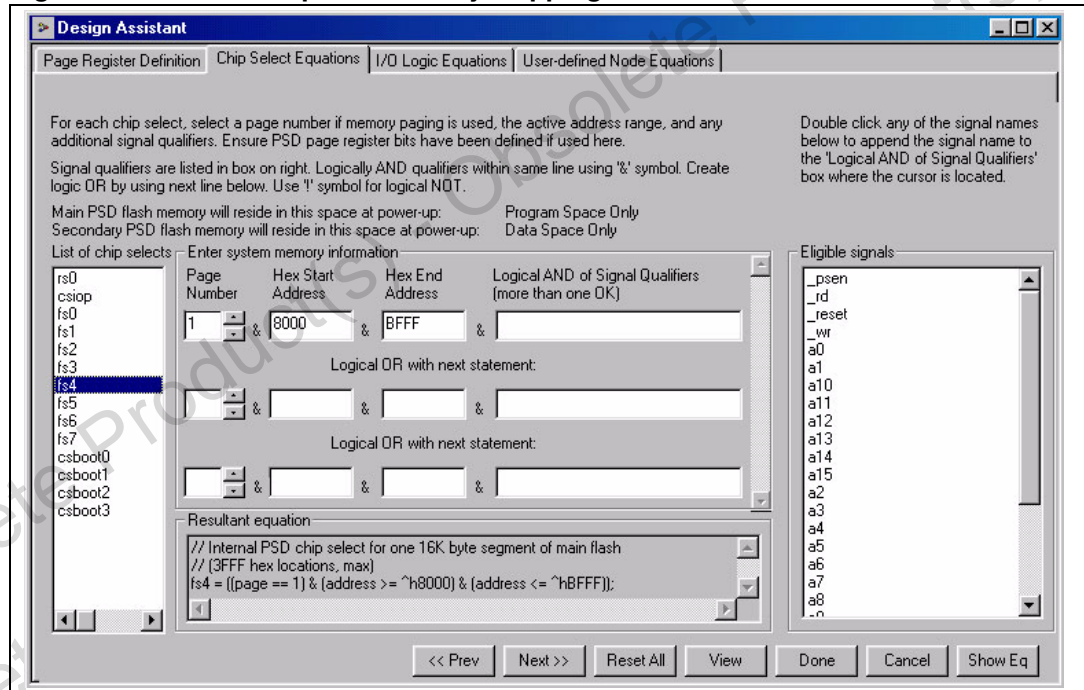

28.2.4 EEPROM emulation

EEPROM emulation is needed if it is desired to repeatedly change only a small number of bytes of data in Flash memory. In this case EEPROM emulation is needed because although Flash memory can be written byte-by-byte, it must be erased sector-by-sector, it is not erasable byte-by-byte (unlike EEPROM which is written AND erased byte-by-byte). So changing one or two bytes in Flash memory typically requires erasing an entire sector each time only one byte is changed within that sector.

However, two of the 8 Kbyte sectors of Secondary Flash memory may be used to emulate EEPROM by using a linked-list software technique to create a small data set that is

maintained by alternating between the two flash sectors. For example, a data set of 128 bytes is written and maintained by software in a distributed fashion across one 8 Kbyte sector of Secondary Flash memory until it becomes full. Then the writing continues on the other 8 Kbyte sector while erasing the first 8 Kbyte sector. This process repeats continuously, bouncing back and forth between the two 8 Kbyte sectors. This creates a wear-leveling effect, which increases the effective number of erase cycles for a data set of 128 bytes to many times more than the base 100 000 erase cycles of the Flash memory. EEPROM emulation in Flash memory is typically faster than writing to actual EEPROM memory, and more reliable because the last known value in a data set is maintained even if a WRITE cycle is corrupted by a power outage. The EEPROM emulation function can be called by the user's firmware, making it appear that the user is writing a single byte, or data record, thus hiding all of the data management that occurs within the two 8 Kbyte Flash sectors. EEPROM emulation firmware for the UPSD34xx is available from www.st.com/psm.

28.2.5 Alternative mapping schemes

Here are more possible memory maps for the UPSD3433.

Note: Mapping examples would be slightly different for UPSD3433 and UPSD3434, because of the different sizes of individual Flash memory sectors.

- **Figure 65** Place the larger Main Flash Memory into program space, but split the Secondary Flash in half, placing two of its sectors into XDATA space and remaining two sectors into program space. This method allows the designer to put IAP code (or boot code) into two sectors of Secondary Flash in program space, and use the other two Secondary Flash sectors for data storage, such as EEPROM emulation in XDATA space.
- **Figure 66** Place both the Main and Secondary Flash memories into program space for maximum code storage, with no Flash memory in XDATA space.

Figure 65. Mapping: split second Flash in half

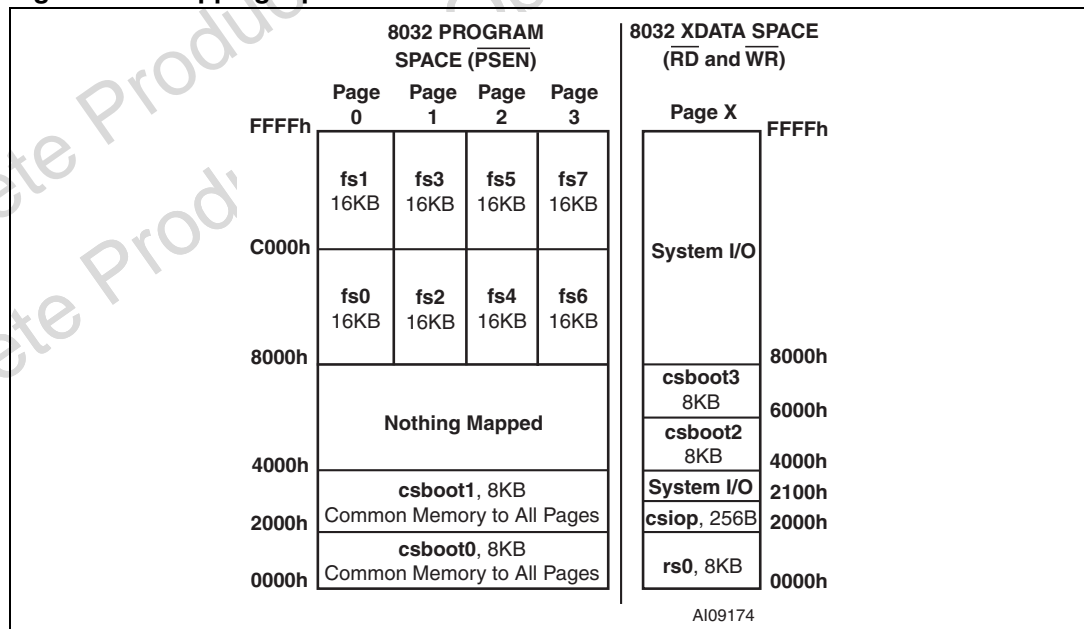
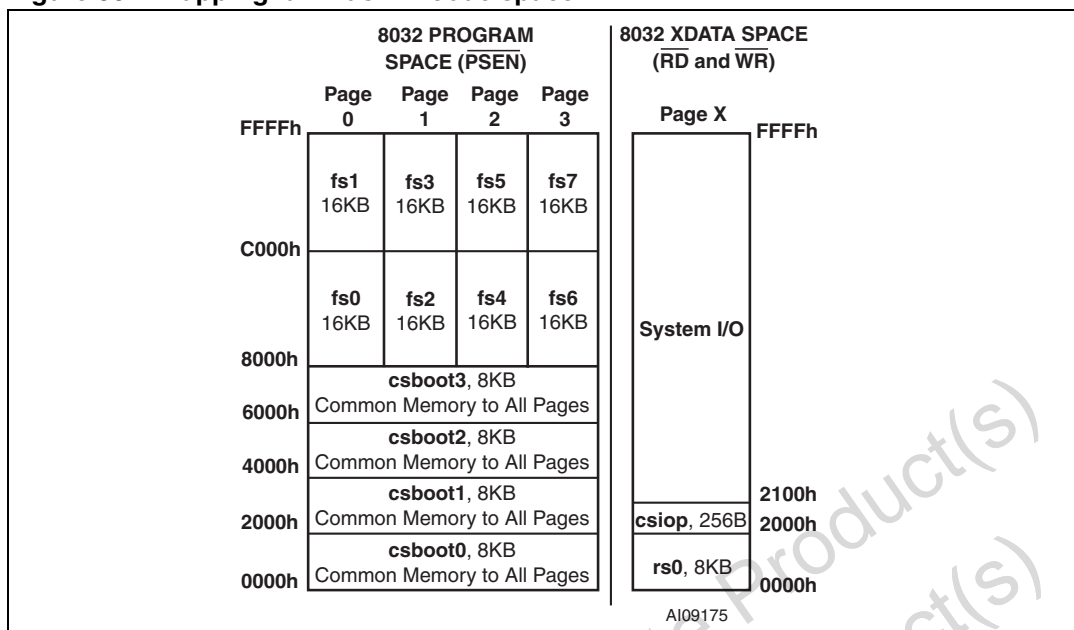
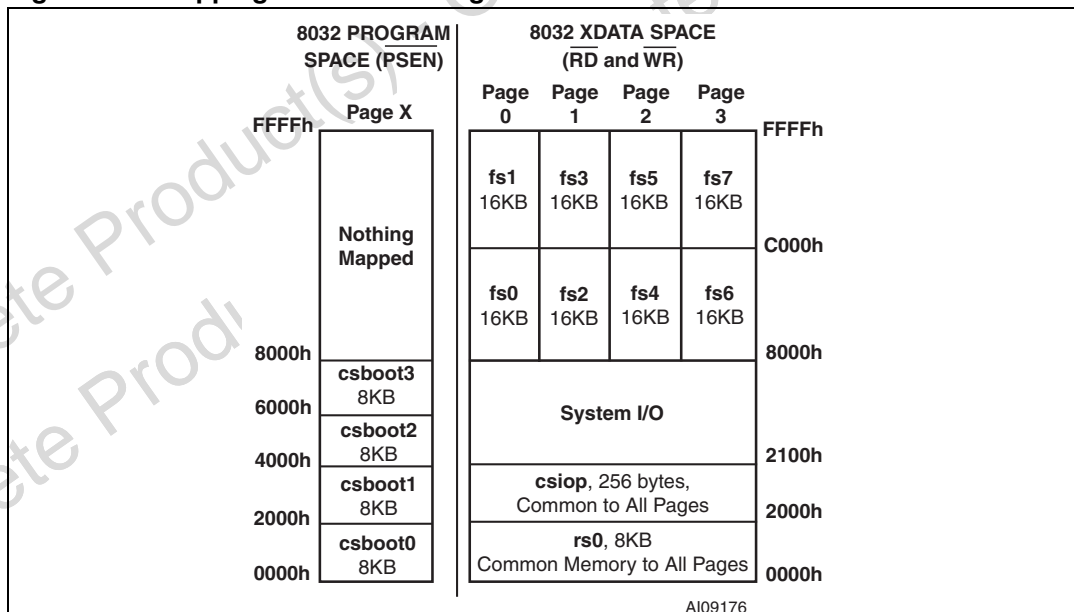

Figure 66. Mapping: all Flash in code space



- **Figure 67** Place the larger Main Flash Memory into XDATA space and the smaller Secondary Flash into program space for systems that need a large amount of Flash for data recording or large look-up tables, and not so much Flash for 8032 firmware.

Figure 67. Mapping: small code / big data



It is also possible to “reclassify” the Flash memories during runtime, moving the memories between XDATA memory space and program memory space on-the-fly. This essentially means that the user can override the initial setting during run-time by writing to a csiop register (the VM register). This is useful for IAP, because standard 8051 architecture does not allow writing to program space. For example, if the user wants to update firmware in Main Flash memory that is residing in program space, the user can temporarily “reclassify” the Main Flash memory into XDATA space to erase and rewrite it while executing IAP code

from the Secondary Flash memory in program space. After the writing is complete, the Main Flash can be “reclassified” back to program space, then execution can continue from the new code in Main Flash memory. The mapping example of [Figure 67](#) will accommodate this operation.

28.2.6 Memory sector select rules

When defining sector select signals (FSx, CSBOOTx, RS0, CSIOP, PSELx) in PSDsoft Express, the user must keep these rules in mind:

- Main Flash and Secondary Flash memory sector select signals may not be larger than their physical sector size as defined in [Table 157 on page 193](#).
- Any Main Flash memory sector select may not be mapped in the same address range as another Main Flash sector select (cannot overlap segments of Main Flash on top of each other).
- Any Secondary Flash memory sector select may not be mapped in the same address range as another Secondary Flash sector select (cannot overlap segments of Secondary Flash on top of each other).
- A Secondary Flash memory sector may overlap a Main Flash memory sector. In the case of overlap, priority is given to the Secondary Flash memory sector.
- SRAM, CSIOP, or PSELx may overlap any Flash memory sector. In the case of overlap, priority is given to SRAM, CSIOP, or PSELx.

Note: PSELx is for optional Peripheral I/O Mode on Port A.

- The address range for sector selects for SRAM, PSELx, and CSIOP must not overlap each other as they have the same priority, causing contention if overlapped.

[Figure 68](#) illustrates the priority scheme of the memory elements of the PSD module. Priority refers to which memory will ultimately produce a byte of data or code to the 8032 MCU for a given bus cycle. Any memory on a higher level can overlap and has priority over any memory on a lower level. Memories on the same level must not overlap.

Example: FS0 is valid when the 8032 produces an address in the range of 8000h to BFFFh. CSBOOT0 is valid from 8000h to 9FFFh. RS0 is valid from 8000h to 87FFh. Any address from the 8032 in the range of RS0 always accesses the SRAM. Any address in the range of CSBOOT0 greater than 87FFh (and less than 9FFFh) automatically addresses Secondary Flash memory. Any address greater than 9FFFh accesses Main Flash memory. One-half of the Main Flash memory segment and one-fourth of the Secondary Flash memory segment cannot be accessed by the 8032.

Figure 68. PSD module memory priority

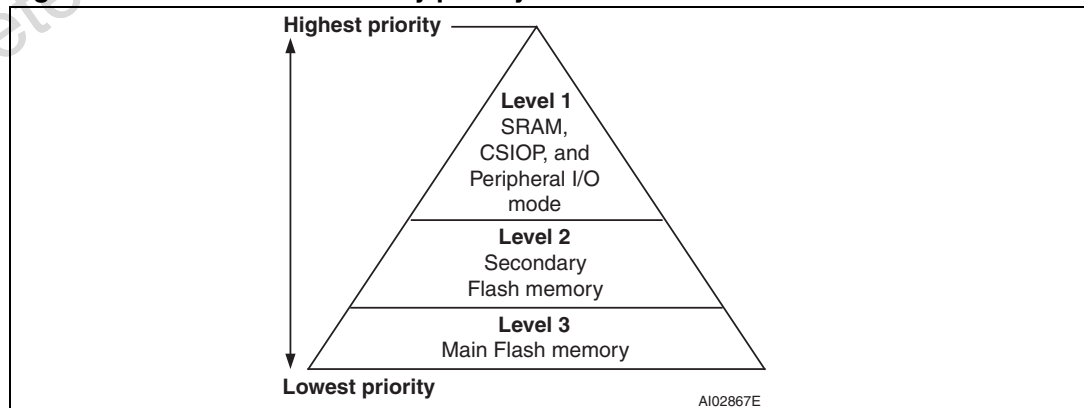

28.2.7 The VM register

One of the *csiop* registers (the VM register) controls whether or not the 8032 bus control signals \overline{RD} , \overline{WR} , and \overline{PSEN} are routed to the Main Flash memory, or the Secondary Flash memory. Routing of these signals to these PSM Module memories determines if memories reside in 8032 program address space, 8032 XDATA space, or both. The initial setting of the VM register is determined by a choice in PSDsoft Express and programmed into the UPSD34xx in a non-volatile fashion using JTAG. This initial setting is loaded into the VM register upon power-up and also loaded upon any reset event. However, the 8032 may override the initial VM register setting at run-time by writing to the VM register, which is useful for IAP.

Table 160 on page 203 defines bit functions within the VM register.

Note: Bit 7, *PIO_EN*, is not related to the memory manipulation functions of Bits 1, 2, 3, and 4. SRAM and *csiop* registers are always in XDATA space and cannot reside in program space.

Figure 69 on page 204 illustrates how the VM register affects the routing of \overline{RD} , \overline{WR} , and \overline{PSEN} to the memories on the PSD module. As an example, if we apply the value 0Ch to the VM register to implement the memory map example shown in Figure 63 on page 198, then the routing of \overline{RD} , \overline{WR} , and \overline{PSEN} would look like that shown in Figure 70 on page 204.

In this example, the configuration is specified in PSDsoft Express and programmed into the UPSD34xx using JTAG. Upon power-on or any reset condition, the non-volatile value 0Ch is loaded into the VM register. At runtime, the value 0Ch in the VM register may be changed (overridden) by the 8032 if desired to implement IAP or other functions.

Table 160. VM register (address = *csiop* + offset E2h)

Bit 7 <i>PIO_EN</i>	Bit 6	Bit 5	Bit 4 Main Flash XDATA space	Bit 3 Secondary Flash XDATA space	Bit 2 Main Flash program space	Bit 1 Secondary Flash program space	Bit 0
0 = disable Peripheral I/O Mode on Port A	not used	not used	0 = \overline{RD} or \overline{WR} cannot access Main Flash	0 = \overline{RD} or \overline{WR} cannot access Secondary Flash	0 = \overline{PSEN} cannot access Main Flash	0 = \overline{PSEN} cannot access Secondary Flash	not used
1 = enable Peripheral I/O Mode on Port A	not used	not used	1 = \overline{RD} or \overline{WR} can access Main Flash	1 = \overline{RD} or \overline{WR} can access Secondary Flash	1 = \overline{PSEN} can access Main Flash	1 = \overline{PSEN} can access Secondary Flash	not used

Note: 1 Default value of Bits 1, 2, 3, and 4 is loaded from Non-Volatile setting as specified from PSDsoft Express upon any reset or power-up condition. The default value of these bits can be overridden by 8032 at run-time.
2 Default value of Bit 7 is zero upon any reset condition.

Figure 69. VM register control of memories

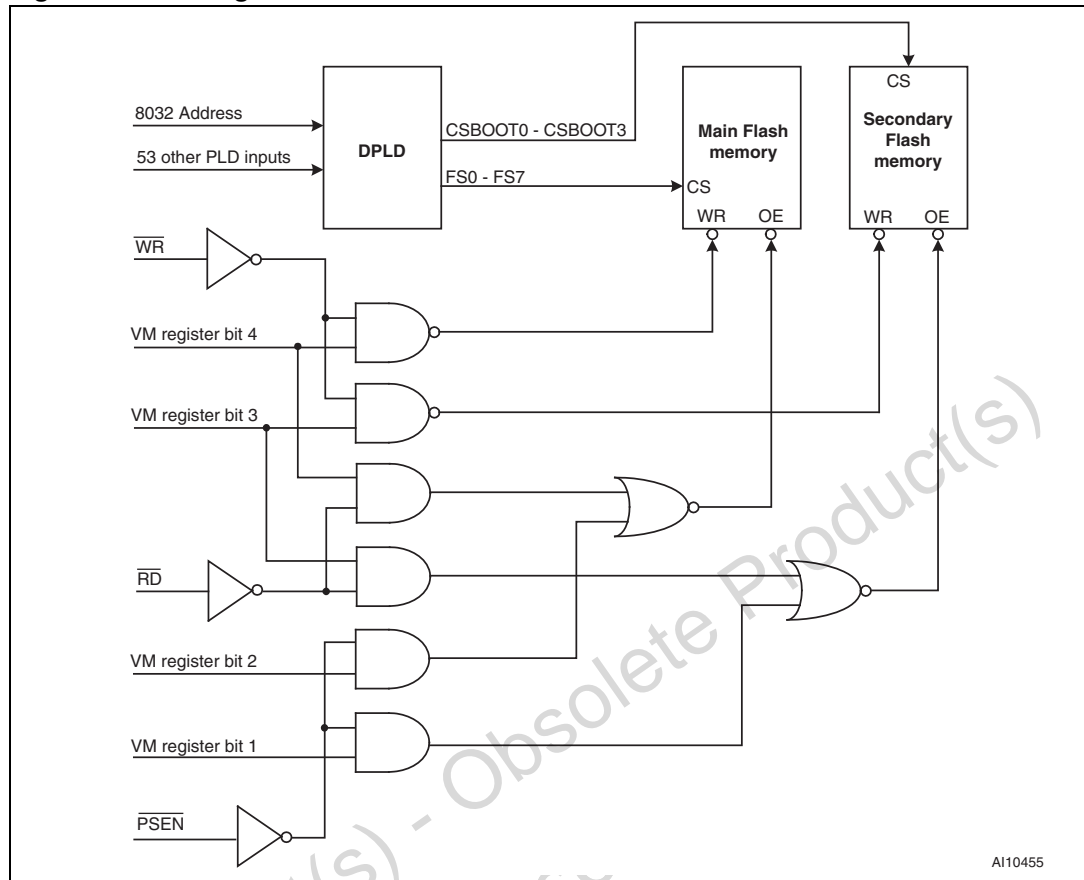
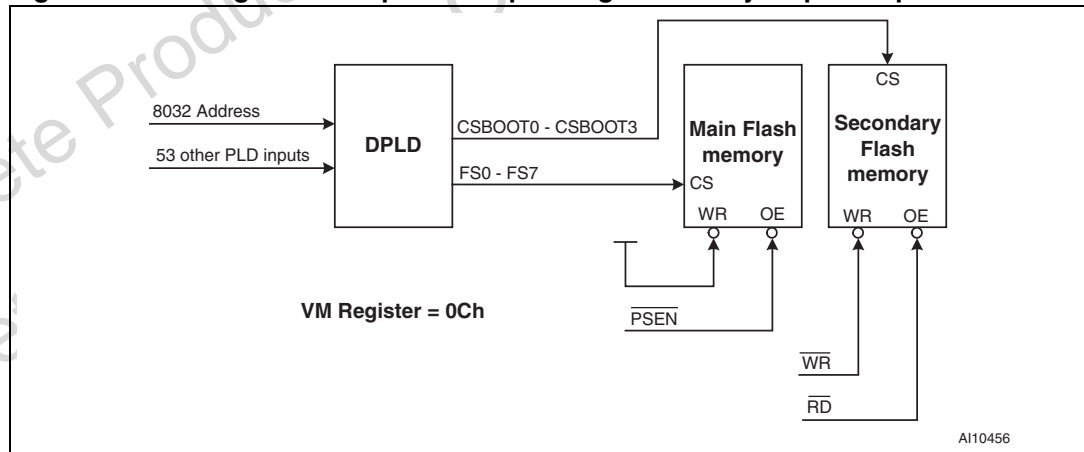

Figure 70. VM register example corresponding to memory map example



28.3 PSD module data bus width

The PSD module functions as an 8-bit device to the MCU module except when the PFQ is fetching instructions from the Flash memory. When PSEN is active, the PSD module always drives 16-bit data out onto the bus.

The Flash memories are 16-bit wide when it is in Program Memory space and are 8-bit wide when it is in the Data Space. When the Flash memory is configured in both “Program Space” and “Data Space,” the Flash will drive 16-bit in a PSEN cycle and operates as an 8-bit memory in READ or WRITE cycle.

The SRAM, csiop, and external device are always in 8-bit data space.

Table 161. Data width in different bus cycles⁽¹⁾

Type of bus cycle	Main Flash	Secondary Flash	SRAM	CSIOP	External device
PSEN cycle (program memory)	16-bit	16-bit	x	x	x
Read or Write cycle (data memory)	8-bit	8-bit	8-bit	8-bit	8-bit
Flash Programming cycle (Flash write or reading status)	8-bit	8-bit	x	x	x

1. x = NA

28.4 Runtime control register definitions (csiop)

The 39 csiop registers are defined in [Table 162](#). The 8032 can access each register by the address offset (specified in [Table 162](#)) added to the csiop base address that was specified in PSDsoft Express. Do not write to unused locations within the csiop block of 256 registers, they should remain logic zero.

Table 162. CSIOP registers and their offsets (in hexadecimal)

Register name	Port A (80-pin)	Port B	Port C	Port D	Other	Description	Link
Data In	00h	01h	10h	11h		MCU I/O input mode. Read to obtain current logic level of pins on Ports A, B, C, or D. No WRITES.	Table 178 on page 234
Control	02h	03h				Selects MCUI/O or Latched Address Out mode. Logic 0 = MCU I/O, 1 = 8032 Addr Out. Write to select mode. Read for status.	Table 190 on page 238
Data Out	04h	05h	12h	13h		MCU I/O output mode. Write to set logic level on pins of Ports A, B, C, or D. Read to check status. This register has no effect if a port pin is driven by an OMC output from PLD.	Table 182 on page 234
Direction	06h	07h	14h	15h		MCU I/O mode. Configures port pin as input or output. Write to set direction of port pins. Logic 1 = out, Logic 0 = in. Read to check status.	Table 186 on page 235

Table 162. CSIOP registers and their offsets (in hexadecimal) (continued)

Register name	Port A (80-pin)	Port B	Port C	Port D	Other	Description	Link
Drive Select	08h	09h	16h	17h		Write to configure port pins as either CMOS push-pull or Open Drain on some pins, while selecting high slew rate on other pins. Read to check status. Default output type is CMOS push-pull.	Table 192 on page 241
Input Macrocells	0Ah	0Bh	18h			Read to obtain logic state of IMCs. No WRITES.	Table 173 on page 230
Enable Out	0Ch	0Dh	1Ah	1Bh		Read state of output enable logic on each I/O port driver. 1 = driver output is enabled, 0 = driver is off, and it is in high impedance state. No WRITES.	Table 196 on page 242
Output Macrocells AB (MCELLAB)					20h	Read logic state of MCELLAB outputs (bank of eight OMCs). Write to load MCELLAB flip-flops.	Table 169 on page 228
Output Macrocells BC (MCELLBC)					21h	Read logic state of MCELLBC outputs (bank of eight OMCs). Write to load MCELLBC flip-flops.	Table 170 on page 228
Mask Macrocells AB					22h	Write to set mask for MCELLAB. Logic '1' blocks READs/WRITEs of OMC. Logic '0' will pass OMC value. Read to check status.	Table 171 on page 229
Mask Macrocells BC					23h	Write to set mask for MCELLBC. Logic '1' blocks READs/WRITEs of OMC. Logic '0' will pass OMC value. Read to check status.	Table 172 on page 229
Main Flash Sector Protection					C0h	Read to determine Main Flash Sector Protection Setting (non-volatile) that was specified in PSDsoft Express. No WRITES.	Table 165 on page 219
Security Bit and Secondary Flash Sector Protection					C2h	Read to determine if PSD module device Security Bit is active (non-volatile) Logic 1 = device secured. Also read to determine Secondary Flash Protection Setting (non-volatile) that was specified in PSDsoft. No WRITES.	Table 166 on page 219

Table 162. CSIOP registers and their offsets (in hexadecimal) (continued)

Register name	Port A (80-pin)	Port B	Port C	Port D	Other	Description	Link
PMMR0					B0h	Power management register 0. WRITE and READ.	Table 200 on page 249
PMMR2					B4h	Power management register 2. WRITE and READ.	Table 201 on page 249
PMMR3					C7h	Power management register 3. WRITE and READ. However, Bit 1 can be cleared only by a reset condition.	Table 202 on page 250
Page					E0h	Memory page register. WRITE and READ.	Table 62 on page 194
VM (Virtual Memory)					E2h	Places PSD module memories into 8032 Program Address Space and/or 8032 XDATA Address Space. (VM overrides initial non-volatile setting that was specified in PSDsoft Express. Reset restores initial setting)	Table 160 on page 203

28.5 PSD module detailed operation

Specific details are given here for the following key functional areas on the PSD module:

- Flash Memories
- PLDs (DPLD and GPLD)
- I/O Ports
- Power Management
- JTAG ISP and Debug Interface

28.5.1 Flash memory operation

The Flash memories are accessed through the 8032 Address, Data, and Control Bus interfaces. Flash memories (and SRAM) cannot be accessed by any other bus master other than the 8032 MCU (these are not dual-port memories).

The 8032 cannot write to Flash memory as it would an SRAM (supply address, supply data, supply WR strobe, assume the data was correctly written to memory). Flash memory must first be “unlocked” with a special instruction sequence of byte WRITE operations to invoke an internal algorithm inside either Flash memory array, then a single data byte is written (programmed) to the Flash memory array, then programming status is checked by a byte READ operation or by checking the Ready/Busy pin (PC3). [Table 163 on page 209](#) lists all of the special instruction sequences to program a byte to either of the Flash memory arrays, erase the arrays, and check for different types of status from the arrays.

This unlocking sequence is typical for many Flash memories to prevent accidental WRITES by errant code. However, it is possible to bypass this unlocking sequence to save time while intentionally programming Flash memory.

Important note: The 8032 may not read and execute code from the same Flash memory array for which it is directing an instruction sequence. Or more simply stated, the 8032 may not read code from the same Flash array that is writing or erasing. Instead, the 8032 must execute code from an alternate memory (like SRAM or a different Flash array) while sending instruction sequences to a given Flash array. Since the two Flash memory arrays inside the PSD module device are completely independent, the 8032 may read code from one array while sending instructions to the other. It is possible, however, to suspend a sector erase operation in one particular Flash array in order to access a different sector within that same Flash array, then resume the erase later.

After a Flash memory array is programmed or erased it will go to "Read Array" mode, then the 8032 can read from Flash memory just as it would read from any ROM or SRAM device.

28.5.2 Flash memory instruction sequences

An instruction sequence consists of a sequence of specific byte WRITE and byte READ operations. Each byte written to either Flash memory array on the PSD module is received by a state machine inside the Flash array and sequentially decoded to execute an embedded algorithm. The algorithm is executed when the correct number of bytes are properly received and the time between two consecutive bytes is shorter than the time-out period of 80µs. Some instruction sequences are structured to include READ operations after the initial WRITE operations.

An instruction sequence must be followed exactly. Any invalid combination of instruction bytes or time-out between two consecutive bytes while addressing Flash memory resets the PSD module Flash logic into Read Array mode (where Flash memory is read like a ROM device). The Flash memories support instruction sequences summarized in [Table 163 on page 209](#).

- Program a byte
- Unlock Sequence Bypass
- Erase memory by array or by sector
- Suspend or resume a sector erase
- Reset to Read Array mode

The first two bytes of an instruction sequence are 8032 bus WRITE operations to "unlock" the Flash array, followed by writing a command byte. The bus operations consist of writing the data AAh to address X555h during the first bus cycle and data 55h to address XAAAh during the second bus cycle. 8032 address signals A12-A15 are "Don't care" during the instruction sequence during WRITE cycles. However, the appropriate sector select signal (*FSx* or *CSBOOTx*) from the DPLD must be active during the entire instruction sequence to complete the entire 8032 address (this includes the page number when memory paging is used). Ignoring A12-A15 means the user has more flexibility in memory mapping. For example, in many traditional Flash memories, instruction sequences must be written to addresses AAAAh and 5555h, not XAAAh and X555h like supported on the PSD module. When the user has to write to AAAAh and 5555h, the memory mapping options are limited.

The Main Flash and Secondary Flash memories each have the same instruction set shown in [Table 163 on page 209](#), but the sector select signals determine which memory array will receive and execute the instructions.

Table 163. Flash memory instruction sequences⁽¹⁾⁽²⁾

Instr. Seq.	Bus Cycle 1	Bus Cycle 2	Bus Cycle 3	Bus Cycle 4	Bus Cycle 5	Bus Cycle 6	Bus Cycle 7	Link
Read Memory Contents (Read Array mode)	Read byte from any valid Flash memory addr							Read memory contents on page 210
Program (write) a byte to Flash Memory	Write AAh to X555h (unlock)	Write 55h to XAAAh (unlock)	Write A0h to X555h (command)	Write data byte to address				Programming Flash memory on page 212
Bypass Unlock	Write AAh to X555h (unlock)	Write 55h to XAAAh (unlock)	Write 20h to X555h (command)					Bypassed unlock sequence on page 215
Program a byte to Flash Memory with Bypassed Unlock	Write A0h to XXXXh (command)	Write data byte to address						Bypassed unlock sequence on page 215
Reset Bypass Unlock	Write 90h to XXXXh (command)	Write 00h to XXXXh (command)						Bypassed unlock sequence on page 215
Flash Bulk Erase ⁽³⁾	Write AAh to X555h (unlock)	Write 55h to XAAAh (unlock)	Write 80h to X555h (command)	Write AAh to X555h (unlock)	Write 55h to XAAAh (unlock)	Write 10h to X555h (command)		Flash bulk erase on page 216
Flash Sector Erase	Write AAh to X555h (unlock)	Write 55h to XAAAh (unlock)	Write 80h to X555h (command)	Write AAh to X555h (unlock)	Write 55h to XAAAh (unlock)	Write 30h to desired Sector (command)	Write 30h to another Sector (command)	Flash sector erase on page 216
Suspend Sector Erase	Write B0h to address that activates FSx or CSBOOTx where erase is in progress (command)							Suspend sector erase on page 217

Table 163. Flash memory instruction sequences⁽¹⁾⁽²⁾ (continued)

Instr. Seq.	Bus Cycle 1	Bus Cycle 2	Bus Cycle 3	Bus Cycle 4	Bus Cycle 5	Bus Cycle 6	Bus Cycle 7	Link
Resume Sector Erase	Write 30h to address that activates FSx or CSBOOTx where desired to resume erase (<i>command</i>)							Resume sector erase on page 217
Reset Flash	Write F0h to address that activates FSx or CSBOOTx in desired array. (<i>command</i>)							Reset Flash on page 218

1. All values are in hexadecimal, X = Don't care.
2. 8032 addresses A12 through A15 are "Don't care" during the instruction sequence decoding. Only address bits A0-A11 are used during decoding of Flash memory instruction sequences. The individual sector select signal (FS0 - FS7 or CSBOOT0-CSBOOT3) which is active during the instruction sequence determines the complete address.
3. Directing this command to any individual sector within a Flash memory array will invoke the bulk erase of all Flash memory sectors within that array.

28.5.3 Reading Flash memory

Under typical conditions, the 8032 may read the Flash memory using READ operations (READ bus cycles) just as it would a ROM or RAM device. Alternately, the 8032 may use READ operations to obtain status information about a Program or Erase operation that is currently in progress. The following sections describe the kinds of READ operations.

28.5.4 Read memory contents

Flash memory is placed in the Read Array mode after Power-up, after a PSD module reset event, or after receiving a Reset Flash memory instruction sequence from the 8032. The 8032 can read Flash memory contents using standard READ bus cycles anytime the Flash array is in Read Array mode. Flash memories will always be in Read Array mode when the array is not actively engaged in a program or erase operation.

28.5.5 Reading the erase/program status bits

The Flash arrays provide several status bits to be used by the 8032 to confirm the completion of an erase or program operation on Flash memory, shown in [Table 164 on page 212](#). The status bits can be read as many times as needed until an operation is complete.

The 8032 performs a READ operation to obtain these status bits while an erase or program operation is being executed by the state machine inside each Flash memory array.

28.5.6 Data polling flag (DQ7)

While programming either Flash memory, the 8032 may read the Data Polling Flag Bit (DQ7), which outputs the complement of the D7 Bit of the byte being programmed into Flash memory. Once the program operation is complete, DQ7 is equal to D7 of the byte just programmed into Flash memory, indicating the program cycle has completed successfully.

The correct select signal, FSx or CSBOOTx, must be active during the entire polling procedure.

Polling may also be used to indicate when an erase operation has completed. During an erase operation, DQ7 is '0.' After the erase is complete DQ7 is '1.' The correct select signal, FSx or CSBOOTx, must be active during the entire polling procedure.

DQ7 is valid after the fourth instruction byte WRITE operation (for program instruction sequence) or after the sixth instruction byte WRITE operation (for erase instruction sequence).

If all Flash memory sectors to be erased are protected, DQ7 is reset to '0' for about 100µs, and then DQ7 returns to the value of D7 of the previously addressed byte. No erasure is performed.

28.5.7 Toggle flag (DQ6)

The Flash memories offer an alternate way to determine when a Flash memory program operation has completed. During the program operation and while the correct sector select FSx or CSBOOTx is active, the Toggle Flag Bit (DQ6) toggles from '0' to '1' and '1' to '0' on subsequent attempts to read any byte of the same Flash array.

When the internal program operation is complete, the toggling stops and the data read on the data bus D0-7 is the actual value of the addressed memory byte. The device is now accessible for a new READ or WRITE operation. The operation is finished when two successive READs yield the same value for DQ6.

DQ6 may also be used to indicate when an erase operation has completed. During an erase operation, DQ6 will toggle from '0' to '1' and '1' to '0' until the erase operation is complete, then DQ6 stops toggling. The erase is finished when two successive READs yield the same value of DQ6. The correct sector select signal, FSx or CSBOOTx, must be active during the entire procedure.

DQ6 is valid after the fourth instruction byte WRITE operation (for program instruction sequence) or after the sixth instruction byte WRITE operation (for erase instruction sequence).

If all the Flash memory sectors selected for erasure are protected, DQ6 toggles to '0' for about 100µs, then returns value of D6 of the previously addressed byte.

28.5.8 Error flag (DQ5)

During a normal program or erase operation, the Error Flag Bit (DQ5) is to '0'. This bit is set to '1' when there is a failure during Flash memory byte program, sector erase, or bulk erase operations.

In the case of Flash memory programming, DQ5 Bit indicates an attempt to program a Flash memory bit from the programmed state of '0,' to the erased state of 1, which is not valid. DQ5 may also indicate a particular Flash cell is damaged and cannot be programmed.

In case of an error in a Flash memory sector erase or byte program operation, the Flash memory sector in which the error occurred or to which the programmed byte belongs must no longer be used. Other Flash memory sectors may still be used. DQ5 is reset after a Reset Flash instruction sequence.

28.5.9 Erase time-out flag (DQ3)

The Erase Time-out Flag Bit (DQ3) reflects the time-out period allowed between two consecutive sector erase instruction sequence bytes. If multiple sector erase commands are desired, the additional sector erase commands (30h) must be sent by the 8032 within 80us after the previous sector erase command. DQ3 is 0 before this time period has expired, indicating it is OK to issue additional sector erase commands. DQ3 will go to logic '1' if the time has been longer than 80us since the previous sector erase command (time has expired), indication that is not OK to send another sector erase command. In this case, the 8032 must start a new sector erase instruction sequence (unlock and command) beginning again after the current sector erase operation has completed.

28.5.10 Programming Flash memory

When a byte of Flash memory is programmed, individual bits are programmed to logic '0.' cannot program a bit in Flash memory to a logic '1' once it has been programmed to a logic '0.' A bit must be erased to logic '1', and programmed to logic '0.' That means Flash memory must be erased prior to being programmed. A byte of Flash memory is erased to all 1s (FFh). The 8032 may erase the entire Flash memory array all at once, or erase individual sector-by-sector, but not erase byte-by-byte. However, even though the Flash memories cannot be *erased* byte-by-byte, the 8032 may *program* Flash memory byte-by-byte. This means the 8032 does not need to program group of bytes (64, 128, etc.) at one time, like some Flash memories.

Each Flash memory requires the 8032 to send an instruction sequence to program a byte or to erase sectors (see [Table 163 on page 209](#)).

If the byte to be programmed is in a protected Flash memory sector, the instruction sequence is ignored.

Important note: It is mandatory that a chip-select signal is active for the Flash sector where a programming instruction sequence is targeted. The user must make sure that the correct chip-select equation, FSx or CSBOOTx specified in PSDsoft Express matches the address range that the 8032 firmware is accessing, otherwise the instruction sequence will not be recognized by the Flash array. If memory paging is used, be sure that the 8032 firmware sets the page register to the correct page number before issuing an instruction sequence to the Flash memory segment on a particular memory page, otherwise the correct sector select signal will not become active.

Once the 8032 issues a Flash memory program or erase instruction sequence, it must check the status bits for completion. The embedded algorithms that are invoked inside a Flash memory array provide several ways to give status to the 8032. Status may be checked using any of three methods: Data Polling, Data Toggle, or Ready/Busy (pin PC3).

Table 164. Flash memory status bit definition^{(1) (2)}

Functional block	FSx, or CSBOOTx	DQ7	DQ6	DQ5	DQ4	DQ3	DQ2	DQ1	DQ0
Flash memory	Active (the desired segment is selected)	Data polling	Toggle flag	Error flag	X	Erase timeout	X	X	X

1. X = Not guaranteed value, can be read either '1' or '0.'
2. DQ7-DQ0 represent the 8032 data bus bits, D7-D0.

28.5.11 Data polling

Polling on the Data Polling Flag Bit (DQ7) is a method of checking whether a program or erase operation is in progress or has completed. [Figure 71](#) shows the Data Polling algorithm.

When the 8032 issues a program instruction sequence, the embedded algorithm within the Flash memory array begins. The 8032 then reads the location of the byte to be programmed in Flash memory to check status. The Data Polling Flag Bit (DQ7) of this location becomes the compliment of Bit D7 of the original data byte to be programmed. The 8032 continues to poll this location, comparing the Data Polling Flag Bit (DQ7) and monitoring the Error Flag Bit (DQ5). When the Data Polling Flag Bit (DQ7) matches Bit D7 of the original data, then the embedded algorithm is complete. If the Error Flag Bit (DQ5) is '1,' the 8032 should test the Data Polling Flag Bit (DQ7) again since the Data Polling Flag Bit (DQ7) may have changed simultaneously with the Error Flag Bit (DQ5) (see [Figure 71](#)).

The Error Flag Bit (DQ5) is set if either an internal time-out occurred while the embedded algorithm attempted to program the byte (indicating a bad Flash cell) or if the 8032 attempted to program bit to logic '1' when that bit was already programmed to logic '0' (must erase to achieve logic '1').

It is suggested (as with all Flash memories) to read the location again after the embedded programming algorithm has completed, to compare the byte that was written to the Flash memory with the byte that was intended to be written.

When using the Data Polling method during an erase operation, [Figure 71](#) still applies. However, the Data Polling Flag Bit (DQ7) is '0' until the erase operation is complete. A '1' on the Error Flag Bit (DQ5) indicates a time-out condition on the Erase cycle, a '0' indicates no error. The 8032 can read any location within the sector being erased to get the Data Polling Flag Bit (DQ7) and the Error Flag Bit (DQ5).

Figure 71. Data polling flowchart

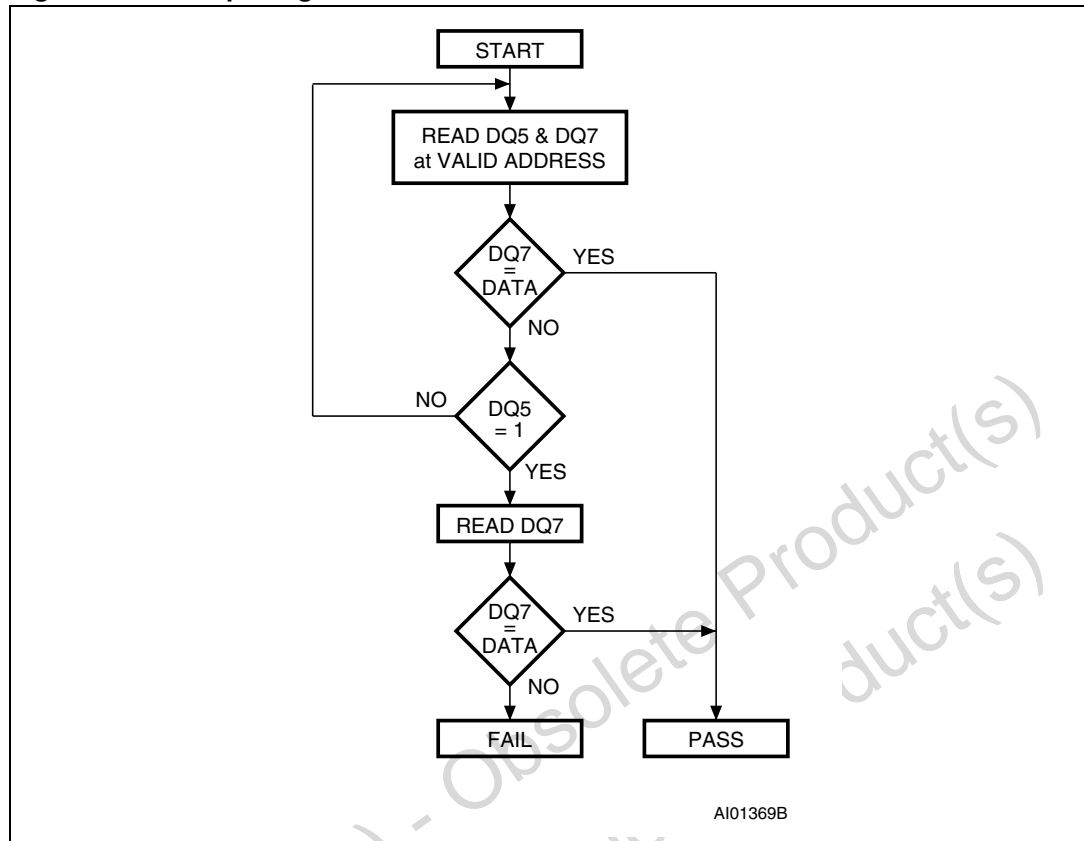

28.5.12 Data toggle

Checking the Toggle Flag Bit (DQ6) is another method of determining whether a program or erase operation is in progress or has completed. [Figure 72](#) shows the Data Toggle algorithm.

When the 8032 issues a program instruction sequence, the embedded algorithm within the Flash memory array begins. The 8032 then reads the location of the byte to be programmed in Flash memory to check status. The Toggle Flag Bit (DQ6) of this location toggles each time the 8032 reads this location until the embedded algorithm is complete. The 8032 continues to read this location, checking the Toggle Flag Bit (DQ6) and monitoring the Error Flag Bit (DQ5). When the Toggle Flag Bit (DQ6) stops toggling (two consecutive reads yield the same value), then the embedded algorithm is complete. If the Error Flag Bit (DQ5) is '1,' the 8032 should test the Toggle Flag Bit (DQ6) again, since the Toggle Flag Bit (DQ6) may have changed simultaneously with the Error Flag Bit (DQ5) (see [Figure 72](#)).

The Error Flag Bit (DQ5) is set if either an internal time-out occurred while the embedded algorithm attempted to program the byte, or if the 8032 attempted to program bit to logic '1' when that bit was already programmed to logic '0' (must erase to achieve logic '1').

It is suggested (as with all Flash memories) to read the location again after the embedded programming algorithm has completed, to compare the byte that was written to Flash memory with the byte that was intended to be written.

When using the Data Toggle method during an erase operation, [Figure 72](#) still applies. the Toggle Flag Bit (DQ6) toggles until the erase operation is complete. A '1' on the Error Flag

Bit (DQ5) indicates a time-out condition on the Erase cycle, a '0' indicates no error. The 8032 can read any location within the sector being erased to get the Toggle Flag Bit (DQ6) and the Error Flag Bit (DQ5).

PSDsoft Express generates ANSI C code functions the user may use to implement these Data Toggling algorithms.

Figure 72. Data toggle flowchart

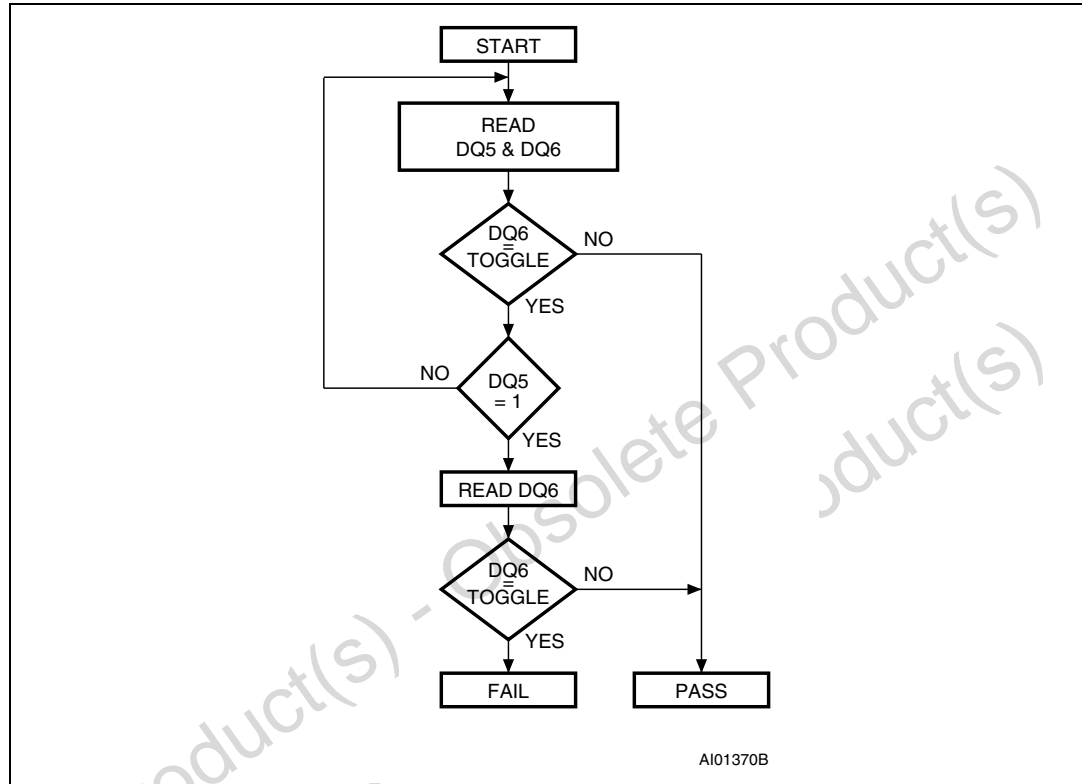

28.5.13 Ready/Busy (PC3)

This signal can be used to output the Ready/Busy status of a program or erase operation on either Flash memory. The output on the Ready/Busy pin is a '0' (Busy) when either Flash memory array is being written, or when either Flash memory array is being erased. The output is a '1' (Ready) when no program or erase operation is in progress. To activate this function on this pin, the user must select the "Ready/Busy" selection in PSDsoft Express when configuring pin PC3. This pin may be polled by the 8032 or used as a 8032 interrupt to indicate when an erase or program operation is complete (requires routing the signal on PC board from PC3 back into a pin on the MCU module). This signal is also available internally on the PSD module as an input to both PLDs (without routing a signal externally on PC board) and its signal name is "rd_bsy". The Ready/Busy output can be probed during lab development to check the timing of Flash memory programming in the system at run-time.

28.5.14 Bypassed unlock sequence

The Bypass Unlock mode allows the 8032 to program bytes in the Flash memories faster than using the standard Flash program instruction sequences because the typical AAh, 55h unlock bus cycles are bypassed for each byte that is programmed. Bypassing the unlock

sequence is typically used when the 8032 is intentionally programming a large number of bytes (such as during IAP). After intentional programming is complete, typically the Bypass mode would be disabled, and full protection is back in place to prevent unwanted WRITES to Flash memory.

The Bypass Unlock mode is entered by first initiating two Unlock bus cycles. This is followed by a third WRITE operation containing the Bypass Unlock command, 20h (as shown in [Table 163 on page 209](#)). The Flash memory array that received that sequence then enters the Bypass Unlock mode. After this, a two bus cycle program operation is all that is required to program a byte in this mode. The first bus cycle in this shortened program instruction sequence contains the Bypassed Unlocked Program command, A0h, to any valid address within the unlocked Flash array. The second bus cycle contains the address and data of the byte to be programmed. Programming status is checked using toggle, polling, or Ready/Busy just as before. Additional data bytes are programmed the same way until this Bypass Unlock mode is exited.

To exit Bypass Unlock mode, the system must issue the Reset Bypass Unlock instruction sequence. The first bus cycle of this instruction must write 90h to any valid address within the unlocked Flash Array; the second bus cycle must write 00h to any valid address within the unlocked Flash Array. After this sequence the Flash returns to Read Array mode.

During Bypass Unlock Mode, only the Bypassed Unlock Program instruction, or the Reset Bypass Unlock instruction is valid, other instruction will be ignored.

28.5.15 Erasing Flash memory

Flash memory may be erased sector-by-sector, or an entire Flash memory array may be erased with one command (bulk).

28.5.16 Flash bulk erase

The Flash Bulk Erase instruction sequence uses six WRITE operations followed by a READ operation of the status register, as described in [Table 163 on page 209](#). If any byte of the Bulk Erase instruction sequence is wrong, the Bulk Erase instruction sequence aborts and the device is reset to the Read Array mode. The address provided by the 8032 during the Flash Bulk Erase command sequence may select any one of the eight Flash memory sector select signals FSx or one of the four signals CSBOOTx. An erase of the entire Flash memory array will occur in a particular array even though a command was sent to just one of the individual Flash memory sectors within that array.

During a Bulk Erase, the memory status may be checked by reading the Error Flag Bit (DQ5), the Toggle Flag Bit (DQ6), and the Data Polling Flag Bit (DQ7). The Error Flag Bit (DQ5) returns a '1' if there has been an erase failure. Details of acquiring the status of the Bulk Erase operation are detailed in the section entitled "[Section 28.5.10: Programming Flash memory on page 212](#)".

During a Bulk Erase operation, the Flash memory does not accept any other Flash instruction sequences.

28.5.17 Flash sector erase

The Sector Erase instruction sequence uses six WRITE operations, as described in [Table 163 on page 209](#). Additional Flash Sector Erase commands to other sectors within the same Flash array may be issued by the 8032 if the additional commands are sent within a limited amount of time.

The Erase Time-out Flag Bit (DQ3) reflects the time-out period allowed between two consecutive sector erase instruction sequence bytes. If multiple sector erase commands are desired, the additional sector erase commands (30h) must be sent by the 8032 to another sector within 80µs after the previous sector erase command. DQ3 is 0 before this time period has expired, indicating it is OK to issue additional sector erase commands. DQ3 will go to logic '1' if the time has been longer than 80µs since the previous sector erase command (time has expired), indicating that it is not OK to send another sector erase command. In this case, the 8032 must start a new sector erase instruction sequence (unlock and command), beginning again after the current sector erase operation has completed.

During a Sector Erase operation, the memory status may be checked by reading the Error Flag Bit (DQ5), the Toggle Flag Bit (DQ6), and the Data Polling Flag Bit (DQ7), as detailed in [Section 28.5.5: Reading the erase/program status bits on page 210](#).

During a Sector Erase operation, a Flash memory accepts only Reset Flash and Suspend Sector Erase instruction sequences. Erasure of one Flash memory sector may be suspended, in order to read data from another Flash memory sector, and then resumed.

The address provided with the initial Flash Sector Erase command sequence ([Table 163 on page 209](#)) must select the first desired sector (FSx or CSBOOTx) to erase. Subsequent sector erase commands that are appended within the time-out period must be addressed to other desired segments within the same Flash memory array.

28.5.18 Suspend sector erase

When a Sector Erase operation is in progress, the Suspend Sector Erase instruction sequence can be used to suspend the operation by writing B0h to any valid address within the Flash array that currently is undergoing an erase operation. This allows reading of data from a different Flash memory sector within the same array after the Erase operation has been suspended. Suspend Sector Erase is accepted only during an Erase operation.

There is up to 15µs delay after the Suspend Sector Erase command is accepted and the array goes to Read Array mode. The 8032 will monitor the Toggle Flag Bit (DQ6) to determine when the erase operation has halted and Read Array mode is active.

If a Suspend Sector Erase instruction sequence was executed, the following rules apply:

- Attempting to read from a Flash memory sector that was being erased outputs invalid data.
- Reading from a Flash memory sector that was *not* being erased is valid.
- The Flash memory *cannot* be programmed, and only responds to Resume Sector Erase and Reset Flash instruction sequences.
- If a Reset Flash instruction sequence is received, data in the Flash memory sector that was being erased is invalid.

28.5.19 Resume sector erase

If a Suspend Sector Erase instruction sequence was previously executed, the erase cycle may be resumed with this instruction sequence. The Resume Sector Erase instruction sequence consists of writing the command 30h to any valid address within the Flash array that was suspended as shown in [Table 163 on page 209](#).

28.5.20 Reset Flash

The Reset Flash instruction sequence resets the embedded algorithm running on the state machine in the targeted Flash memory (Main or Secondary) and the memory goes into Read Array mode. The Reset Flash instruction consists of one bus WRITE cycle as shown in [Table 163 on page 209](#), and it must be executed after any error condition that has occurred during a Flash memory Program or Erase operation.

It may take the Flash memory up to 25 μ s to complete the Reset cycle. The Reset Flash instruction sequence is ignored when it is issued during a Program or Bulk Erase operation. The Reset Flash instruction sequence aborts any on-going Sector Erase operation and returns the Flash memory to Read Array mode within 25 μ s.

28.5.21 Reset signal applied to Flash memory

Whenever the PSD module receives a reset signal from the MCU module, any operation that is occurring in either Flash memory array will be aborted and the array(s) will go to Read Array mode. It may take up to 25 μ s to abort an operation and achieve Read Array mode.

A reset from the MCU module will result from any of these events: an active signal on the UPSD34xx $\overline{\text{RESET_IN}}$ input pin, a watchdog timer time-out, detection of low V_{CC} , or a JTAG debug channel reset event.

28.5.22 Flash memory sector protection

Each Flash memory sector can be separately protected against program and erase operations. This mode can be activated (or deactivated) by selecting this feature in PSDsoft Express and then programming through the JTAG Port. Sector protection can be selected for individual sectors, and the 8032 cannot override the protection during run-time. The 8032 can read, but not change, sector protection.

Any attempt to program or erase a protected Flash memory sector is ignored. The 8032 may read the contents of a Flash sector even when a sector is protected.

Sector protection status is not read using Flash memory instruction sequences, but instead this status is read by the 8032 reading two registers within csiop address space shown in [Table 165](#) and [Table 166](#).

28.5.23 Flash memory protection during power-up

Flash memory WRITE operations are automatically prevented while V_{DD} is ramping up until it rises above V_{LKO} voltage threshold at which time Flash memory WRITE operations are allowed.

28.5.24 PSD module security bit

A programmable security bit in the PSD module protects its contents from unauthorized viewing and copying. The security bit is set using PSDsoft Express and programmed into the PSD module with JTAG. When set, the security bit will block access of JTAG programming equipment from reading or modifying the PSD module Flash memory and PLD configuration. The security bit also blocks JTAG access to the MCU module for debugging. The only way to defeat the security bit is to erase the entire PSD module using JTAG (erase is the only JTAG operation allowed while security bit is set), after which the device is blank and may be used again. The 8032 MCU will always have access to Flash

memory contents through its 8-bit data bus even while the security bit is set. The 8032 can read the status of the security bit at run-time (but it cannot change it) by reading the csiop register defined in [Table 166](#).

Table 165. Main Flash memory protection register definition (address = csiop + offset C0h)⁽¹⁾

Bit 7	Bit 6	Bit 5	Bit 4	Bit 3	Bit 2	Bit 1	Bit 0
Sec7_Prot	Sec6_Prot	Sec5_Prot	Sec4_Prot	Sec3_Prot	Sec2_Prot	Sec1_Prot	Sec0_Prot

1. *Bit definitions:*
Sec<i>_Prot 1 = Flash memory sector <i> is write protected, 0 = Flash memory sector <i> is not write protected.

Table 166. Secondary Flash memory protection/security register definition (csiop + offset C2h)

Bit 7	Bit 6	Bit 5	Bit 4	Bit 3 ⁽¹⁾	Bit 2 ⁽¹⁾	Bit 1 ⁽¹⁾	Bit 0 ⁽¹⁾
Security_Bit ⁽²⁾	not used	not used	not used	Sec3_Prot	Sec2_Prot	Sec1_Prot	Sec0_Prot

1. *Sec<i>_Prot 1 = Flash memory sector <i> is write protected, 0 = Flash memory sector <i> is not write protected.*
2. *Security_Bit = 1, device is secured, 0 = not secured.*

28.5.25 PLDs

The PSD module contains two PLDs: the Decode PLD (DPLD), and the General PLD (GPLD), as shown in [Figure 73 on page 221](#). Both PLDs are fed by a common PLD input signal bus, and additionally, the GPLD is connected to the 8032 data bus.

PLD logic is specified using PSDsoft Express and programmed into the PSD module using the JTAG ISP channel. PLD logic is non-volatile and available at power-up. PLDs may not be programmed by the 8032. The PLDs have selectable levels of performance and power consumption.

The DPLD performs address decoding, and generates select signals for internal and external components, such as memory, registers, and I/O ports. The DPLD can generate External Chip-Select (ECS1-ECS2) signals on Port D.

The GPLD can be used for logic functions, such as loadable counters and shift registers, state machines, encoding and decoding logic. These logic functions can be constructed from a combination of 16 Output Macrocells (OMC), 20 Input Macrocells (IMC), and the AND-OR Array.

Routing of the 16 OMCs outputs can be divided between pins on three Ports A, B, or C by the OMC Allocator as shown in [Figure 77 on page 227](#). Eight of the 16 OMCs that can be routed to pins on Port A or Port B and are named MCELLAB0-MCELLAB7. The other eight OMCs to be routed to pins on Port B or Port C and are named MCELLBC0-MCELLBC7. This routing depends on the pin number assignments that are specified in PSDsoft Express for "PLD Outputs" in the Pin Definition section. OMC outputs can also be routed internally (not to pins) used as buried nodes to create shifters, counters, etc.

The AND-OR Array is used to form product terms. These product terms are configured from the logic definitions entered in PSDsoft Express. A PLD Input Bus consisting of 69 signals is connected to both PLDs. Input signals are shown in [Table 167](#), both the true and compliment versions of each of these signals are available at inputs to each PLD.

Note: The 8032 data bus, D0 - D7, does not route directly to PLD inputs. Instead, the 8032 data bus has indirect access to the GPLD (not the DPLD) when the 8032 reads and writes the OMC and IMC registers within csiop address space.

28.5.26 Turbo bit and PLDs

The PLDs can minimize power consumption by going to standby after ALL the PLD inputs remain unchanged for an extended time (about 70ns). When the Turbo Bit is set to logic one (Bit 3 of the csiop PMMR0 register), Turbo mode is turned off and then this automatic standby mode is achieved. Turning off Turbo mode increases propagation delays while reducing power consumption. The default state of the Turbo Bit is logic zero, meaning Turbo mode is on. Additionally, four bits are available in the csiop PMMR0 and PMMR2 registers to block the 8032 bus control signals (\overline{RD} , \overline{WR} , \overline{PSEN} , ALE) from entering the PLDs. This reduces power consumption and can be used only when these 8032 control signals are not used in PLD logic equations. See [Section 28.5.52: Power management on page 248](#).

Table 167. DPLD and GPLD inputs

Input source	Input name	Number of signals
8032 address bus	A0-A15	16
8032 bus control signals	\overline{PSEN} , \overline{RD} , \overline{WR} , ALE	4
Reset from MCU module	\overline{RESET}	1
Power-Down from Auto-Power Down counter	PDN	1
PortA input macrocells (80-pin devices only)	PA0-PA7	8
PortB input macrocells	PB0-PB7	8
PortC input macrocells	PC2, PC3, PC4, PC7	4
Port D inputs (52-pin devices have only PD1)	PD1, PD2	2
Page register	PGR0-PGR7	8
Macrocell OMC bank AB Feedback	MCELLAB FB0-7	8
Macrocell OMC bank BC Feedback	MCELLBC FB0-7	8
Flash memory status bit	Ready/ \overline{Busy}	1

Figure 73. DPLD and GPLD

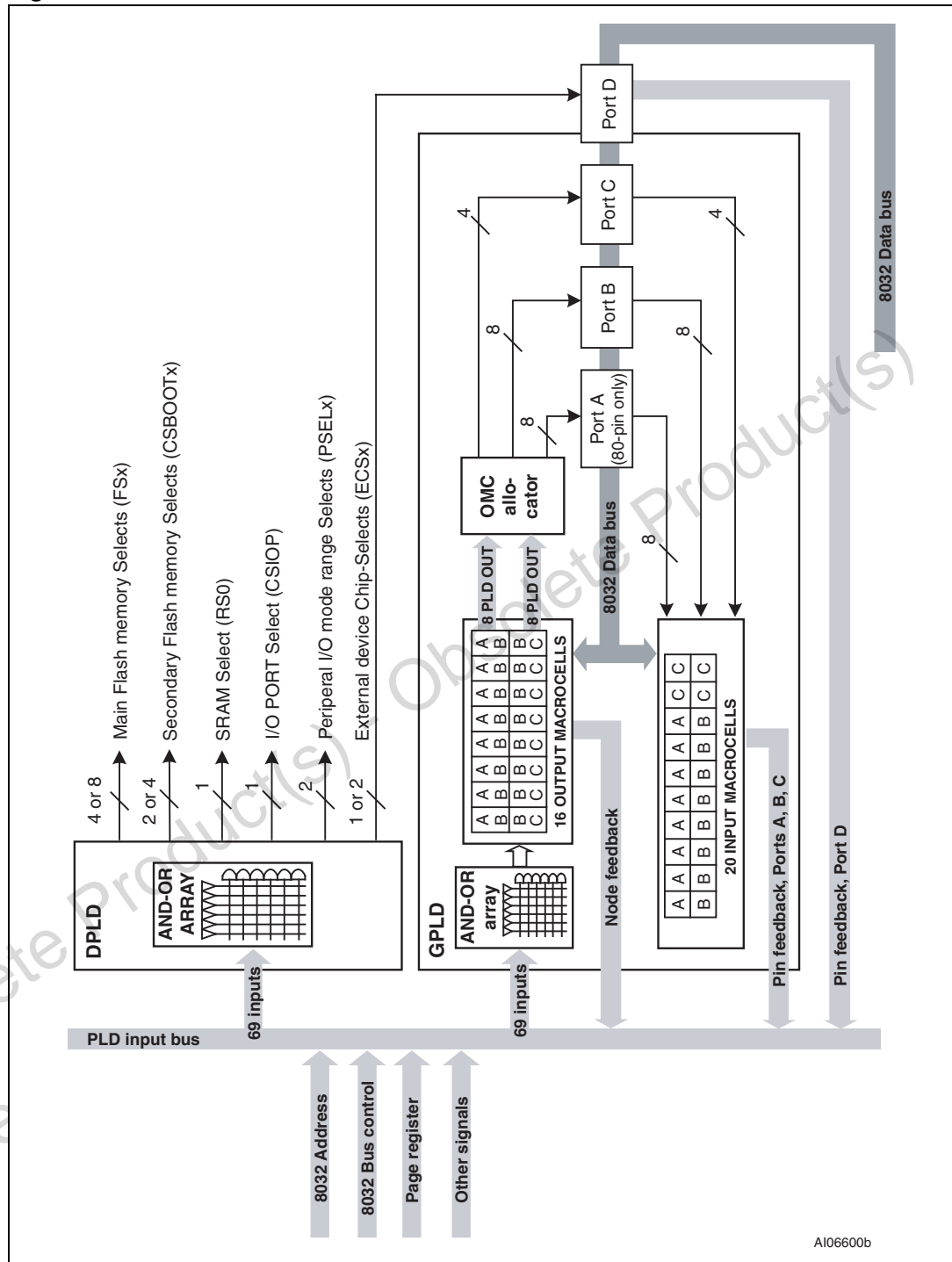

A106600b

28.5.27 Decode PLD (DPLD)

The DPLD ([Figure 74 on page 223](#)) generates the following memory decode signals:

- Eight Main Flash memory sector select signals (FS0-FS7) with three product terms each
- Four Secondary Flash memory sector select signals (CSBOOT0-CSBOOT3) with three product terms each
- One SRAM select signal (RS0) with two product terms
- One select signal for the base address of 256 PSD module device control and status registers (csiop) with one product term
- Two external chip-select output signals for Port D pins, each with one product term (52-pin devices only have one pin on Port D)
- Two chip-select signals (PSEL0, PSEL1) used to enable the 8032 data bus repeater function (Peripheral I/O mode) for Port A on 80-pin devices. Each has one product term.

A product term indicates the logical OR of two or more inputs. For example, three product terms in a DPLD output means the final output signal is capable of representing the logical OR of three different input signals, each input signal representing the logical AND of a combination of the 69 PLD inputs.

Using the signal FS0 for example, the user may create a 3-product term chip select signal that is logic true when any one of three different address ranges are true... FS0 = address range 1 OR address range 2 OR address range 3.

The phrase “one product term” is a bit misleading, but commonly used in this context. One product term is the logical AND of two or more inputs, with no OR logic involved at all, such as the CSIOP signal in [Figure 74 on page 223](#).

Figure 74. DPLD logic array

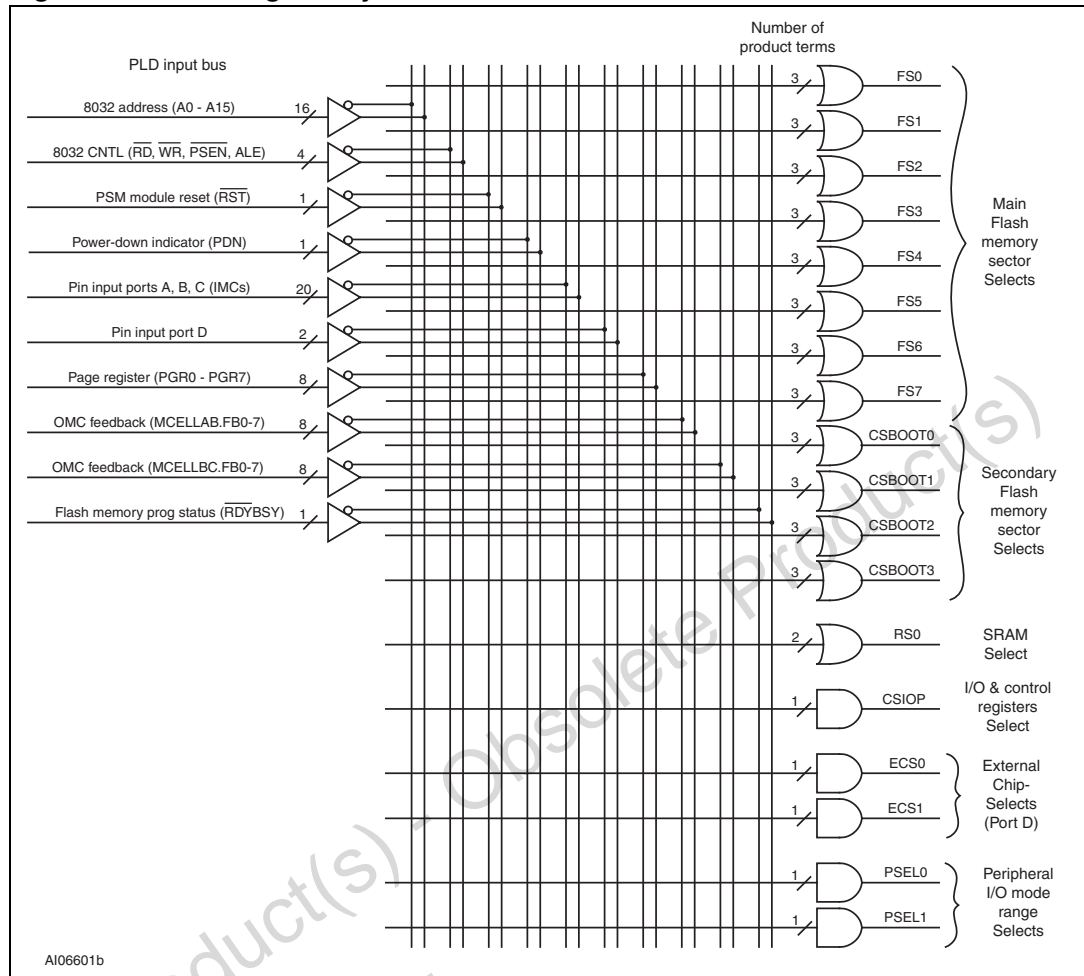

28.5.28 General PLD (GPLD)

The GPLD is used to create general system logic. [Figure 73 on page 221](#) shows the architecture of the entire GPLD, and [Figure 75 on page 224](#) shows the relationship between one OMC, one IMC, and one I/O port pin, which is representative of pins on Ports A, B, and C. It is important to understand how these elements work together. A more detailed description will follow for the three major blocks (OMC, IMC, I/O Port) shown in [Figure 75](#). [Figure 75](#) also shows which csiop registers to access for various PLD and I/O functions.

The GPLD contains:

- 16 Output Macrocells (OMC)
- 20 Input Macrocells (IMC)
- OMC Allocator
- Product Term Allocator inside each OMC
- AND-OR Array capable of generating up to 137 product terms
- Three I/O Ports, A, B, and C

28.5.29 Output macrocell

The GPLD has 16 OMCs. Architecture of one individual OMC is shown in [Figure 76](#). OMCs can be used for internal node feedback (buried registers to build shift registers, etc.), or their outputs may be routed to external port pins. The user can choose any mixture of OMCs used for buried functions and OMCs used to drive port pins.

Referring to [Figure 76](#), for each OMC there are native product terms available from the AND-OR Array to form logic, and also borrowed product terms are available (if unused) from other OMCs. The polarity of the final product term output is controlled by the XOR gate. Each OMC can implement sequential logic using the flip-flop element, or combinatorial logic when bypassing the flip-flop as selected by the output multiplexer. An OMC output can drive a port pin through the OMC Allocator, it can also drive the 8032 data bus, and also it can drive a feedback path to the AND-OR Array inputs, all at the same time.

The flip-flop in each OMC can be synthesized as a D, T, JK, or SR type in PSDsoft Express. OMC flip-flops are specified using PSDsoft Express in the "User Defined Nodes" section of the Design Assistant. Each flip-flop's clock, preset, and clear inputs may be driven individually from a product term of the AND-OR Array, defined by equations in PSDsoft Express for signals *.c, *.pr, and *.re respectively. The preset and clear inputs on the flip-flops are level activated, active-high logic signals. The clock inputs on the flip-flops are rising-edge logic signals.

Optionally, the signal CLKIN (pin PD1) can be used for a common clock source to all OMC flip-flops. Each flip-flop is clocked on the rising edge. A common clock is specified in PSDsoft Express by assigning the function "Common Clock Input" for pin PD1 in the Pin Definition section, and then choosing the signal CLKIN when specifying the clock input (*.c) for individual flip-flops in the "User Defined Nodes" section.

Figure 76. Detail of a single OMC

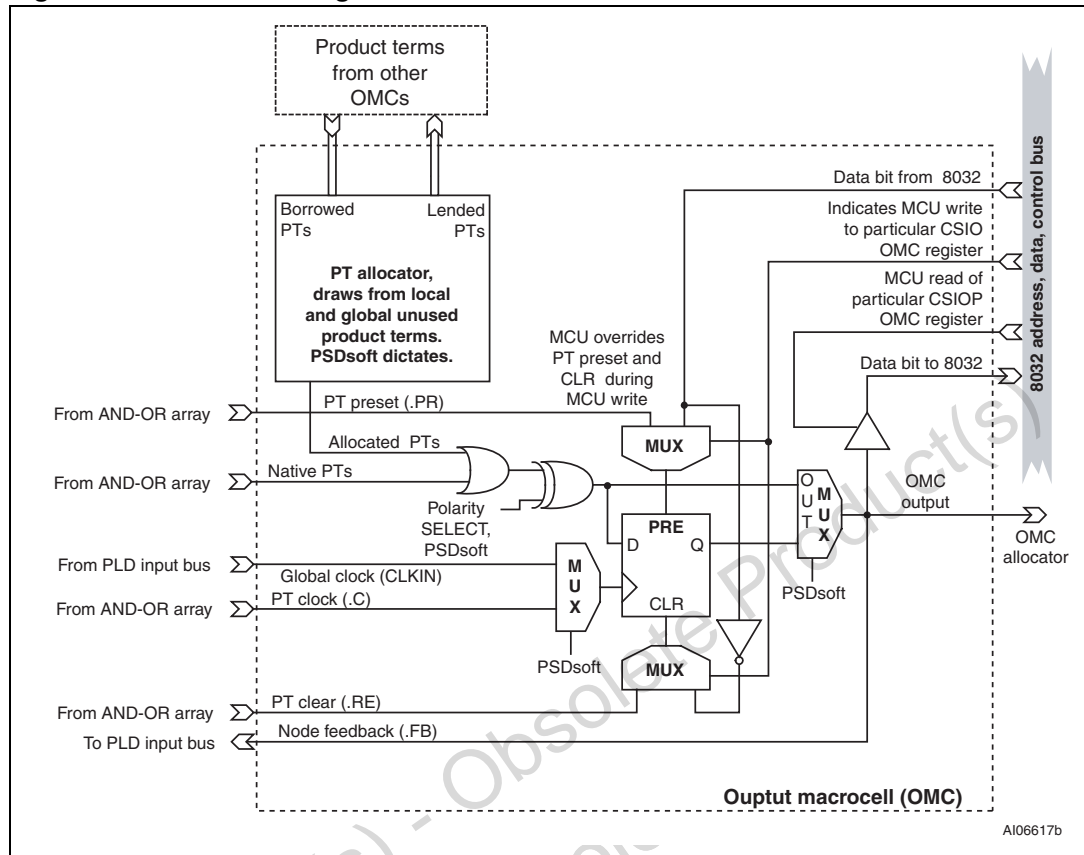

28.5.30 OMC allocator

Outputs of the 16 OMCs can be routed to a combination of pins on Port A (80-pin devices only), Port B, or Port C as shown in Figure 77. OMCs are routed to port pins automatically after specifying pin numbers in PSDsoft Express. Routing can occur on a bit-by-bit basis, spitting OMC assignment between the ports. However, one OMC can be routed to one only port pin, not both ports.

28.5.31 Product term allocator

Each OMC has a Product Term Allocator as shown in Figure 76 on page 226. PSDsoft Express uses PT Allocators to give and take product terms to and from other OMCs to fit a logic design into the available silicon resources. This happens automatically in PSDsoft Express, but understanding how PT allocation works will help if the logic design does not “fit”, in which case the user may try selecting a different pin or different OMC for the logic where more product terms may be available. The following list summarizes how product terms are allocated to each OMC, as shown in Table 168 on page 227.

- MCELLAB0-MCELLAB7 each have three native product terms and may borrow up to six more
- MCELLBC0-MCELLBC3 each have four native product terms and may borrow up to five more
- MCELLBC4-MCELLBC7 each have four native product terms and may borrow up to six more.

Native product terms come from the AND-OR Array. Each OMC may borrow product terms only from certain other OMCs, if they are not in use. Product term allocation does not add any propagation delay to the logic. The fitter report generated by PSDsoft Express will show any PT allocation that has occurred.

If an equation requires more product terms than are available to it through PT allocation, then “external” product terms are required, which consumes other OMCs. This is called product term expansion and also happens automatically in PSDsoft Express as needed. PT expansion causes additional propagation delay because an additional OMC is consumed by the expansion process and its output is rerouted (or fed back) into the AND-OR array. The user can examine the fitter report generated by PSDsoft Express to see resulting PT allocation and PT expansion (expansion will have signal names, such as ‘*.fb_0’ or ‘*.fb_1’). PSDsoft Express will always try to fit the logic design first by using PT allocation, and if that is not sufficient then PSDsoft Express will use PT expansion.

Product term expansion may occur in the DPLD for complex chip select equations for Flash memory sectors and for SRAM, but this is a rare occurrence. If PSDsoft Express does use PT expansion in the DPLD, it results in an approximate 15ns additional propagation delay for that chip select signal, which gives 15ns less time for the memory to respond. Be aware of this and consider adding a wait state to the 8032 bus access (using the SFR named, BUSCON), or lower the 8032 clock frequency to avoid problems with memory access time.

Figure 77. OMC allocator

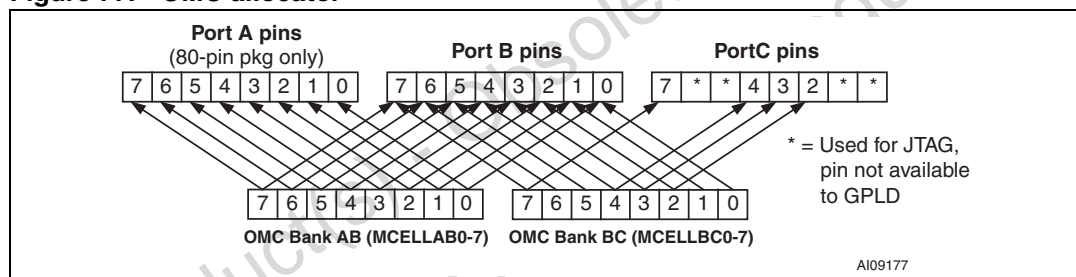

Table 168. OMC port and data bit assignments

OMC	Port assignment ^{(1),(2)}	Native product terms from AND-OR array	Maximum borrowed product terms	Data bit on 8032 data bus for loading or reading OMC
MCELLAB0	Port A0 or B0	3	6	D0
MCELLAB1	Port A1 or B1	3	6	D1
MCELLAB2	Port A2 or B2	3	6	D2
MCELLAB3	Port A3 or B3	3	6	D3
MCELLAB4	Port A4 or B4	3	6	D4
MCELLAB5	Port A5 or B5	3	6	D5
MCELLAB6	Port A6 or B6	3	6	D6
MCELLAB7	Port A7 or B7	3	6	D7
MCELLBC0	Port B0	4	5	D0
MCELLBC1	Port B1	4	5	D1
MCELLBC2	Port B or C2	4	5	D2

Table 168. OMC port and data bit assignments (continued)

OMC	Port assignment ^{(1),(2)}	Native product terms from AND-OR array	Maximum borrowed product terms	Data bit on 8032 data bus for loading or reading OMC
MCELLBC3	Port B3 or C3	4	5	D3
MCELLBC4	Port B4 or C4	4	6	D4
MCELLBC5	Port B5	4	6	D5
MCELLBC6	Port B6	4	6	D6
MCELLBC7	Port B7 or C7	4	6	D7

- MCELLAB0-MCELLAB7 can be output to Port A pins only on 80-pin devices. Port A is not available on 52-pin devices.
- Port pins PC0, PC1, PC5, and PC6 are dedicated JTAG pins and are not available as outputs for MCELLBC 0, 1, 5, or 6.

28.5.32 Loading and reading OMCs

Each of the two OMC groups (eight OMCs each) occupies a byte in csiop space, named MCELLAB and MCELLBC (see [Table 169](#) and [Table 170](#)). When the 8032 writes or reads these two OMC registers in csiop it is accessing each of the OMCs through its 8-bit data bus, with the bit assignment shown in [Table 168 on page 227](#). Sometimes it is important to know the bit assignment when the user builds GPLD logic that is accessed by the 8032. For example, the user may create a 4-bit counter that must be loaded and read by the 8032, so the user must know which nibble in the corresponding csiop OMC register the firmware must access. The fitter report generated by PSDsoft Express will indicate how it assigned the OMCs and data bus bits to the logic. The user can optionally force PSDsoft Express to assign logic to specific OMCs and data bus bits if desired by using the 'PROPERTY' statement in PSDsoft Express. Please see the PSDsoft Express User's Manual for more information on OMC assignments.

Loading the OMC flip-flops with data from the 8032 takes priority over the PLD logic functions. As such, the preset, clear, and clock inputs to the flip-flop can be asynchronously overridden when the 8032 writes to the csiop registers to load the individual OMCs.

Table 169. Output macrocell MCELLAB (address = csiop + offset 20h)⁽¹⁾

Bit 7	Bit 6	Bit 5	Bit 4	Bit 3	Bit 2	Bit 1	Bit 0
MCELLAB 7	MCELLAB 6	MCELLAB 5	MCELLAB 4	MCELLAB 3	MCELLAB 2	MCELLAB 1	MCELLAB 0

- All bits clear to logic '0' at power-on reset, but do not clear after warm reset conditions (non-power-on reset).

Table 170. Output macrocell MCELLBC (address = csiop + offset 21h)⁽¹⁾

Bit 7	Bit 6	Bit 5	Bit 4	Bit 3	Bit 2	Bit 1	Bit 0
MCELLBC 7	MCELLBC 6	MCELLBC 5	MCELLBC 4	MCELLBC 3	MCELLBC 2	MCELLBC 1	MCELLBC 0

- All bits clear to logic '0' at power-on reset, but do not clear after warm reset conditions (non-power-on reset).

28.5.33 OMC mask registers

There is one OMC Mask register for each of the two groups of eight OMCs shown in [Table 171](#) and [Table 172](#). The OMC mask registers are used to block loading of data to individual OMCs. The default value for the mask registers is 00h, which allows loading of all OMCs. When a given bit in a mask register is set to a '1,' the 8032 is blocked from writing to the associated OMC flip-flop. For example, suppose that only four of eight OMCs (MCELLAB0-3) are being used for a state machine. The user may not want the 8032 to write to all the OMCs in MCELLAB because it would overwrite the state machine registers. Therefore, the user would want to load the mask register for MCELLAB with the value 0Fh before writing OMCs.

Table 171. Output macrocell MCELLAB mask register (address = csiop + offset 22h)

Bit 7	Bit 6	Bit 5	Bit 4	Bit 3	Bit 2	Bit 1	Bit 0
Mask MCELLAB 7	Mask MCELLAB 6	Mask MCELLAB 5	Mask MCELLAB 4	Mask MCELLAB 3	Mask MCELLAB 2	Mask MCELLAB 1	Mask MCELLAB 0

- Note: 1 Default is 00h after any reset condition
 2 1 = block writing to individual macrocell, 0 = allow writing to individual macrocell

Table 172. Output macrocell MCELLBC mask register (address = csiop + offset 23h)

Bit 7	Bit 6	Bit 5	Bit 4	Bit 3	Bit 2	Bit 1	Bit 0
Mask MCELLBC 7	Mask MCELLBC 6	Mask MCELLBC 5	Mask MCELLBC 4	Mask MCELLBC 3	Mask MCELLBC 2	Mask MCELLBC 1	Mask MCELLBC 0

- Note: 1 Default is 00h after any reset condition
 2 1 = block writing to individual macrocell, 0 = allow writing to individual macrocell

28.5.34 Input macrocells

The GPLD has 20 IMCs, one for each pin on Port A (80-pin device only), one for each pin on Port B, and for the four pins on Port C that are not JTAG pins. The architecture of one individual IMC is shown in [Figure 78 on page 230](#). IMCs are individually configurable, and they can strobe a signal coming in from a port pin as a latch (gated), or as a register (clocked), or the IMC can pass the signal without strobing, all prior to driving the signal onto the PLD input bus. Strobing is useful for sampling and debouncing inputs (keypad inputs, etc.) before entering the PLD AND-OR arrays. The outputs of IMCs can be read by the 8032 asynchronously when the 8032 reads the csiop registers shown in [Table 173](#), [Table 174](#), and [Table 175 on page 230](#). It is possible to read a PSD module port pin using one of two different methods, one method is by reading IMCs as described here, the other method is using MCU I/O mode described in a later section.

The optional IMC clocking or gating signal used to strobe pin inputs is driven by a product term from the AND-OR array. There is one clocking or gating product term available for each group of four IMCs. Port inputs 0-3 are controlled by one product term and 4-7 by another. To specify in PSDsoft Express the method in which a signal will be strobed as it enters an IMC for a given input pin on Port A, B, or C, just specify "PT Clocked register" to use a rising edge to clock the incoming signal, or specify "PT Clock Latch" to use an active high gate

signal to latch the incoming signal. Then define an equation for the IMC clock (.ld) or the IMC gate (.le) signal in the “I/O Equations” section.

If the user would like to latch an incoming signal using the gate signal ALE from the 8032, then in PSDsoft Express, for a given input pin on Port A, B, or C, specify “Latched Address” as the pin function.

If it is desired to pass an incoming signal through an IMC directly to the AND-OR array inputs without clocking or gating (this is most common), in PSDsoft Express simply specify “Logic or Address” for the input pin function on Port A, B, or C.

Figure 78. Detail of a single IMC

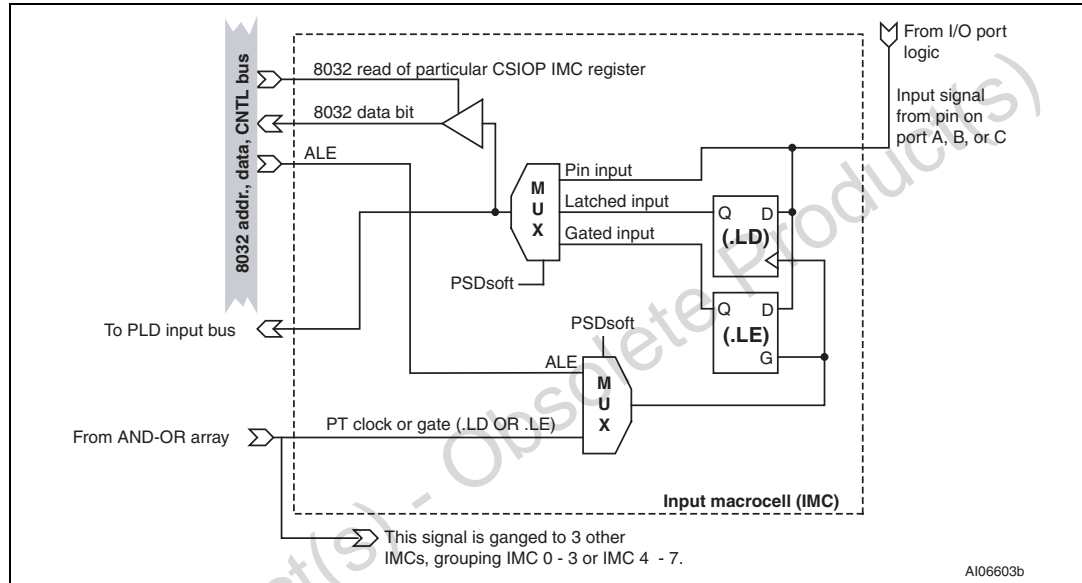

Table 173. Input macrocell port A⁽¹⁾ (address = csioip + offset 0Ah)⁽²⁾

Bit 7	Bit 6	Bit 5	Bit 4	Bit 3	Bit 2	Bit 1	Bit 0
IMC PA7	IMC PA6	IMC PA5	IMC PA4	IMC PA3	IMC PA2	IMC PA1	IMC PA0

1. Port A not available on 52-pin UPSD34xx devices.
2. 1 = current state of IMC is logic '1,' 0 = current state is logic '0'.

Table 174. Input macrocell port B (address = csioip + offset 0Bh)⁽¹⁾

Bit 7	Bit 6	Bit 5	Bit 4	Bit 3	Bit 2	Bit 1	Bit 0
IMC PB7	IMC PB6	IMC PB5	IMC PB4	IMC PB3	IMC PB2	IMC PB1	IMC PB0

1. 1 = current state of IMC is logic '1,' 0 = current state is logic '0'.

Table 175. Input macrocell port C (address = csioip + offset 18h)⁽¹⁾ ⁽²⁾

Bit 7	Bit 6	Bit 5	Bit 4	Bit 3	Bit 2	Bit 1	Bit 0
IMC PC7	X	X	IMC PC4	IMC PC3	IMC PC2	X	X

1. X = Not guaranteed value, can be read either '1' or '0.' These are JTAG pins.
2. 1 = current state of IMC is logic '1,' 0 = current state is logic '0'.

28.5.35 I/O ports

There are four programmable I/O ports on the PSD module: Port A (80-pin device only), Port B, Port C, and Port D. Ports A and B are eight bits each, Port C is four bits, and Port D is two bits for 80-pin devices or 1-bit for 52-pin devices. Each port pin is individually configurable, thus allowing multiple functions per port. The ports are configured using PSDsoft Express then programming with JTAG, and also by the 8032 writing to csiop registers at run-time.

Topics discussed in this section are:

- General port architecture
- Port operating modes
- Individual port structure

28.5.36 General port architecture

The general architecture for a single I/O Port pin is shown in [Figure 79 on page 232](#). Port structures for Ports A, B, C, and D differ slightly and are shown in [Figure 84 on page 243](#) though [Figure 87 on page 247](#).

[Figure 79 on page 232](#) shows four csiop registers whose outputs are determined by the value that the 8032 writes to csiop Direction, Drive, Control, and Data Out. The I/O Port logic contains an output mux whose mux select signal is determined by PSDsoft Express and the csiop Control register bits at run-time. Inputs to this output mux include the following:

1. Data from the csiop Data Out register for MCU I/O output mode (All ports)
2. Latched de-multiplexed 8032 Address for Address Output mode (Ports A and B only)
3. Peripheral I/O mode data bit (Port A only)
4. GPLD OMC output (Ports A, B, and C).

The Port Data Buffer (PDB) provides feedback to the 8032 and allows only one source at a time to be read when the 8032 reads various csiop registers. There is one PDB for each port pin enabling the 8032 to read the following on a pin-by-pin basis:

1. MCU I/O signal direction setting (csiop Direction reg)
2. Pin drive type setting (csiop Drive Select reg)
3. Latched Addr Out mode setting (csiop Control reg)
4. MCU I/O pin output setting (csiop Data Out reg)
5. Output Enable of pin driver (csiop Enable Out reg)
6. MCU I/O pin input (csiop Data In reg)

A port pin's output enable signal is controlled by a two input OR gate whose inputs come from: a product term of the AND-OR array; the output of the csiop direction register. If an output enable from the AND-OR Array is not defined, and the port pin is not defined as an OMC output, and if Peripheral I/O mode is not used, then the csiop direction register has sole control of the OE signal.

As shown in [Figure 79 on page 232](#), a physical port pin is connected to the I/O Port logic and is also separately routed to an IMC, allowing the 8032 to read a port pin by two different methods (MCU I/O input mode or read the IMC).

28.5.37 Port operating modes

I/O Port logic has several modes of operation. [Table 171 on page 229](#) summarizes which modes are available on each port. Each of the port operating modes are described in

following sections. Some operating modes can be defined using PSDsoft Express, and some by the 8032 writing to the csiop registers at run-time, and some require both. For example, PLD I/O, Latched Address Out, and Peripheral I/O modes must be defined in PSDsoft Express and programmed into the device using JTAG, but an additional step must happen at run-time to activate Latched Address Out mode and Peripheral I/O mode, but not needed for PLD I/O. In another example, MCU I/O mode is controlled completely by the 8032 at run-time and only a simple pin name declaration is needed in PSDsoft Express for documentation.

Table 172 on page 229 summarizes what actions are needed in PSDsoft Express and what actions are required by the 8032 at run-time to achieve the various port functions.

Figure 79. Detail of a single I/O port (typical of ports A, B, C)

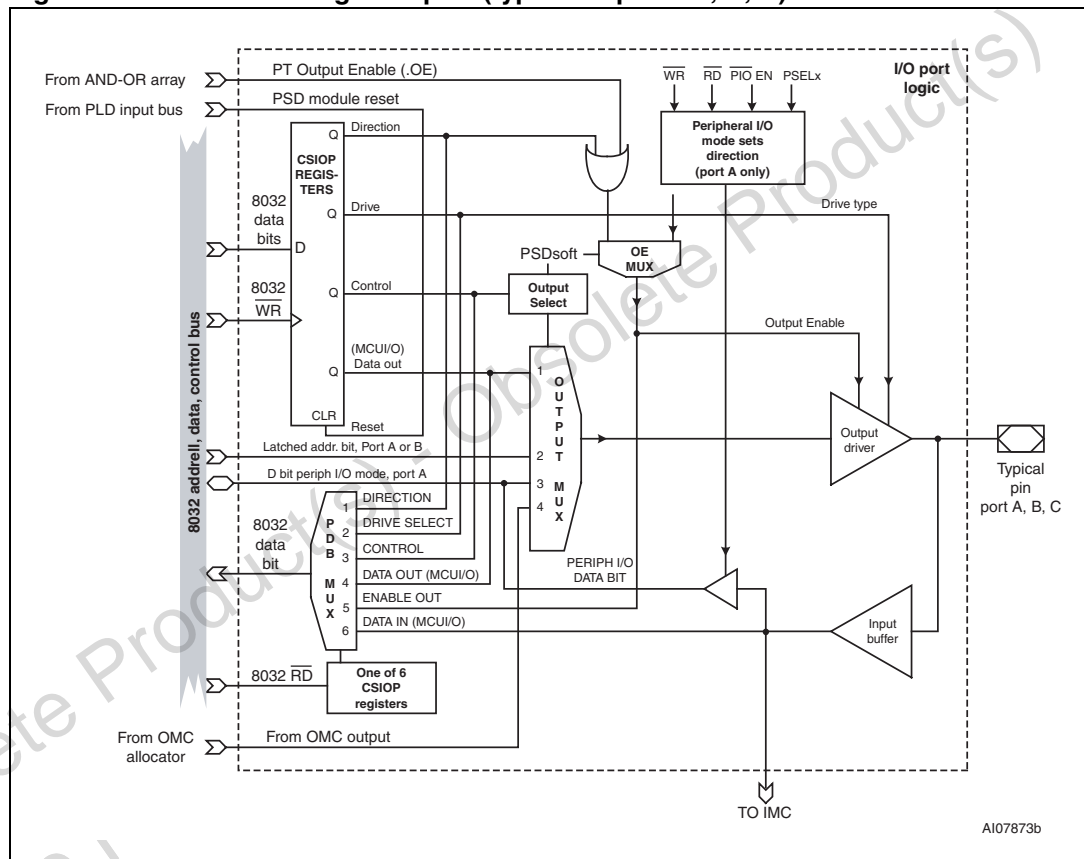

Table 176. Port operating modes

Port operating mode	Port A (80-pin only)	Port B	Port C	Port D	Find it
MCU I/O	Yes	Yes	Yes	Yes	MCU I/O mode on page 233
PLD I/O					
OMC MCELLAB outputs	Yes	Yes	No	No	PLD I/O mode on page 236
OMC MCELLBC outputs	No	Yes	Yes ⁽¹⁾	No	
External Chip-Select outputs	No	No	No	Yes	
PLD inputs	Yes	Yes	Yes	Yes	

Table 176. Port operating modes (continued)

Port operating mode	Port A (80-pin only)	Port B	Port C	Port D	Find it
Latched address output	Yes	Yes	No	No	<i>Latched address output mode on page 238</i>
Peripheral I/O mode	Yes	No	No	No	<i>Peripheral I/O mode on page 239</i>
JTAG ISP	No	No	Yes ⁽²⁾	No	<i>JTAG ISP mode on page 240</i>

1. MCELLBC outputs available only on pins PC2, PC3, PC4, and PC7.
2. JTAG pins (PC0/TMS, PC1/TCK, PC5/TDI, PC6/TDO) are dedicated to JTAG pin functions (cannot be used for general I/O).

Table 177. Port configuration setting requirements

Port operating mode	Required action in PSDsoft Express to configure each pin	Value that 8032 writes to csiop control register at run-time	Value that 8032 writes to csiop direction register at run-time	Value that 8032 writes to Bit 7 (PIO_EN) of csiop VM register at run-time
MCU I/O	Choose the MCU I/O function and declare the pin name	Logic '0' (default)	Logic 1 = out of uPSD Logic 0 = into uPSD	N/A
PLD I/O	Choose the PLD function type, declare pin name, and specify logic equation(s)	N/A	Direction register has no effect on a pin if pin is driven from OMC output	N/A
Latched address output	Choose Latched Address Out function, declare pin name	Logic '1'	Logic '1' Only	N/A
Peripheral I/O	Choose Peripheral I/O mode function and specify address range in DPLD for PSELx	N/A	N/A	PIO_EN bit = logic 1 (default is '0')
4-PIN JTAG ISP	No action required in PSDsoft to get 4-pin JTAG. By default TDO, TDI, TCK, TMS are dedicated JTAG functions.	N/A	N/A	N/A
6-PIN JTAG ISP (faster programming)	Choose JTAG TSTAT function for pin PC3 and JTAG \overline{TERR} function for pin PC4.	N/A	N/A	N/A

28.5.38 MCU I/O mode

In MCU I/O mode, the 8032 on the MCU module expands its own I/O by using the I/O Ports on the PSD module. The 8032 can read PSD module I/O pins, set the direction of the I/O

pins, and change the output state of I/O pins by accessing the Data In, Direction, and Data Out csiop registers respectively at run-time.

To implement MCU I/O mode, each desired pin is specified in PSDsoft Express as *MCU I/O* function and given a pin name. Then 8032 firmware is written to set the Direction bit for each corresponding pin during initialization routines (0 = In, 1 = Out of the chip), then the 8032 firmware simply reads the corresponding Data In register to determine the state of an I/O pin, or writes to a Data Out register to set the state of a pin. The Direction of each pin may be changed dynamically by the 8032 if desired. A mixture of input and output pins within a single port is allowed. [Figure 79 on page 232](#) shows the Data In, Data Out, and Direction signal paths.

The Data In registers are defined in [Table 178](#) to [Table 181](#). The Data Out registers are defined in [Table 182](#) to [Table 185 on page 235](#). The Direction registers are defined in [Table 186](#) to [Table 189 on page 236](#).

Table 178. MCU I/O mode port A data in register⁽¹⁾ (address = csiop + offset 00h)⁽²⁾

Bit 7	Bit 6	Bit 5	Bit 4	Bit 3	Bit 2	Bit 1	Bit 0
PA7	PA6	PA5	PA4	PA3	PA2	PA1	PA0

1. Port A not available on 52-pin UPSD34xx devices.
2. For each bit, 1 = current state of input pin is logic '1,' 0 = current state is logic '0'.

Table 179. MCU I/O mode port B data in register (address = csiop + offset 01h)⁽¹⁾

Bit 7	Bit 6	Bit 5	Bit 4	Bit 3	Bit 2	Bit 1	Bit 0
PB7	PB6	PB5	PB4	PB3	PB2	PB1	PB0

1. For each bit, 1 = current state of input pin is logic '1,' 0 = current state is logic '0'.

Table 180. MCU I/O mode port C data in register (address = csiop + offset 10h)⁽¹⁾ (2)

Bit 7	Bit 6	Bit 5	Bit 4	Bit 3	Bit 2	Bit 1	Bit 0
PC7	X	X	PC4	PC3	PC2	X	X

1. X = Not guaranteed value, can be read either '1' or '0.'
2. For each bit, 1 = current state of input pin is logic '1,' 0 = current state is logic '0'

Table 181. MCU I/O mode port D Data in register (address = csiop + offset 11h)⁽¹⁾ (2)

Bit 7	Bit 6	Bit 5	Bit 4	Bit 3	Bit 2	Bit 1	Bit 0
X	X	X	X	X	PD2 ⁽³⁾	PD1	X

1. X = Not guaranteed value, can be read either '1' or '0.'
2. For each bit, 1 = current state of input pin is logic '1,' 0 = current state is logic '0'
3. Not available on 52-pin UPSD34xx devices.

Table 182. MCU I/O mode port A data out register⁽¹⁾ (address = csiop + offset 04h)⁽²⁾⁽³⁾

Bit 7	Bit 6	Bit 5	Bit 4	Bit 3	Bit 2	Bit 1	Bit 0
PA7	PA6	PA5	PA4	PA3	PA2	PA1	PA0

1. Port A not available on 52-pin UPSD34xx devices.
2. For each bit, 1 = drive port pin to logic '1,' 0 = drive port pin to logic '0'.
3. Default state of register is 00h after reset or power-up.

Table 183. MCU I/O mode port B data out register (address = csiop + offset 05h)⁽¹⁾⁽²⁾

Bit 7	Bit 6	Bit 5	Bit 4	Bit 3	Bit 2	Bit 1	Bit 0
PB7	PB6	PB5	PB4	PB3	PB2	PB1	PB0

- For each bit, 1 = drive port pin to logic '1,' 0 = drive port pin to logic '0'.
- Default state of register is 00h after reset or power-up.

Table 184. MCU I/O mode port C data out register (address = csiop + offset 12h)⁽¹⁾⁽²⁾

Bit 7	Bit 6	Bit 5	Bit 4	Bit 3	Bit 2	Bit 1	Bit 0
PC7	N/A	N/A	PC4	PC3	PC2	N/A	N/A

- For each bit, 1 = drive port pin to logic '1,' 0 = drive port pin to logic '0'.
- Default state of register is 00h after reset or power-up.

Table 185. MCU I/O mode port D data out register (address = csiop + offset 13h)⁽¹⁾⁽²⁾

Bit 7	Bit 6	Bit 5	Bit 4	Bit 3	Bit 2	Bit 1	Bit 0
N/A	N/A	N/A	N/A	N/A	PD2 ⁽³⁾	PD1	N/A

- For each bit, 1 = drive port pin to logic '1,' 0 = drive port pin to logic '0'.
- Default state of register is 00h after reset or power-up.
- Not available on 52-pin UPSD34xx devices.

Table 186. MCU I/O mode port A direction register⁽¹⁾ (address = csiop + offset 06h)⁽²⁾⁽³⁾

Bit 7	Bit 6	Bit 5	Bit 4	Bit 3	Bit 2	Bit 1	Bit 0
PA7	PA6	PA5	PA4	PA3	PA2	PA1	PA0

- Port A not available on 52-pin UPSD34xx devices.
- For each bit, 1 = out from UPSD34xx port pin1, 0 = in to PSD34xx port pin.
- Default state for register is 00h after reset or power-up.

Table 187. MCU I/O mode port B direction in register (address = csiop + offset 07h)⁽¹⁾⁽²⁾

Bit 7	Bit 6	Bit 5	Bit 4	Bit 3	Bit 2	Bit 1	Bit 0
PB7	PB6	PB5	PB4	PB3	PB2	PB1	PB0

- For each bit, 1 = out from UPSD34xx port pin1, 0 = in to PSD34xx port pin.
- Default state for register is 00h after reset or power-up.

Table 188. MCU I/O mode port C direction register (address = csiop + offset 14h)⁽¹⁾⁽²⁾

Bit 7	Bit 6	Bit 5	Bit 4	Bit 3	Bit 2	Bit 1	Bit 0
PC7	N/A	N/A	PC4	PC3	PC2	N/A	N/A

- For each bit, 1 = out from UPSD34xx port pin1, 0 = in to PSD34xx port pin.
- Default state for register is 00h after reset or power-up.

Table 189. MCU I/O mode port D direction register (address = csiop + offset 15h)⁽¹⁾⁽²⁾

Bit 7	Bit 6	Bit 5	Bit 4	Bit 3	Bit 2	Bit 1	Bit 0
N/A	N/A	N/A	N/A	N/A	PD2 ⁽³⁾	PD1	N/A

1. For each bit, 1 = out from UPSD34xx port pin1, 0 = in to PSD34xx port pin.
2. Default state for register is 00h after reset or power-up.
3. Not available on 52-pin uPSD34xx devices.

28.5.39 PLD I/O mode

Pins on Ports A, B, C, and D can serve as inputs to either the DPLD or the GPLD. Inputs to these PLDs from Ports A, B, and C are routed through IMCs before reaching the PLD input bus. Inputs to the PLDs from Port D do not pass through IMCs, but route directly to the PLD input bus.

Pins on Ports A, B, and C can serve as outputs from GPLD OMCs, and Port D pins can be outputs from the DPLD (external chip-selects) which do not consume OMCs.

Whenever a pin is specified to be a PLD output, it cannot be used for MCU I/O mode, or other pin modes. If a pin is specified to be a PLD input, it is still possible to read the pin using MCU I/O input mode with the csiop register Data In. Also, the csiop Direction register can still affect a pin which is used for a PLD input. The csiop Data Out register has no effect on a PLD output pin.

Each pin on Ports A, B, C, and D have a tri-state buffer at the final output stage. The Output Enable signal for this buffer is driven by the logical OR of two signals. One signal is an Output Enable signal generated by the AND-OR array (from an .oe equation specified in PSDsoft), and the other signal is the output of the csiop Direction register. This logic is shown in [Figure 79 on page 232](#). At power-on, all port pins default to high-impedance input (Direction registers default to 00h). However, if an equation is written for the Output Enable that is active at power-on, then the pin will behave as an output.

PLD I/O equations are specified in PSDsoft Express and programmed into the uPSD using JTAG. [Figure 80](#) shows a very simple combinatorial logic example which is implemented on pins of Port B.

To give a general idea of how PLD logic is implemented using PSDsoft Express, [Figure 81 on page 237](#) illustrates the pin declaration window of PSDsoft Express, showing the PLD output at pin PB0 declared as “Combinatorial” in the “PLD Output” section, and a signal name, “pld_out”, is specified. The other three signals on pins PB1, PB2, and PB3 would be declared as “Logic or Address” in the “PLD Input” section, and given signal names.

In the “Design Assistant” window of PSDsoft Express shown in [Figure 82 on page 238](#), the user simply enters the logic equation for the signal “pld_out” as shown. The user can either type in the logic statements or enter them using a point-and-click method, selecting various signal names and logic operators available in the window.

After PSDsoft Express has accepted and realized the logic from the equations, it synthesizes the logic statement:

```
pld_out = ( pld_in_1 # pld_in_2 ) & !pld_in_3;
```

to be programmed into the GPLD. See the PSDsoft User’s Manual for all the steps.

Note: If a particular OMC output is specified as an internal node and not specified as a port pin output in PSDsoft Express, then the port pin that is associated with that OMC can be used for other I/O functions.

Figure 80. Simple PLD logic example

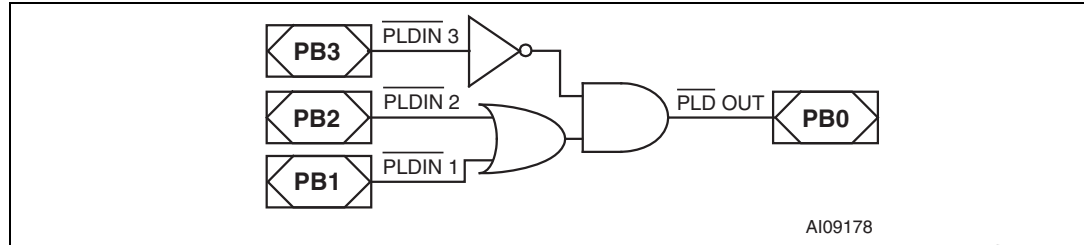

Figure 81. Pin declarations in PSDsoft express for simple PLD example

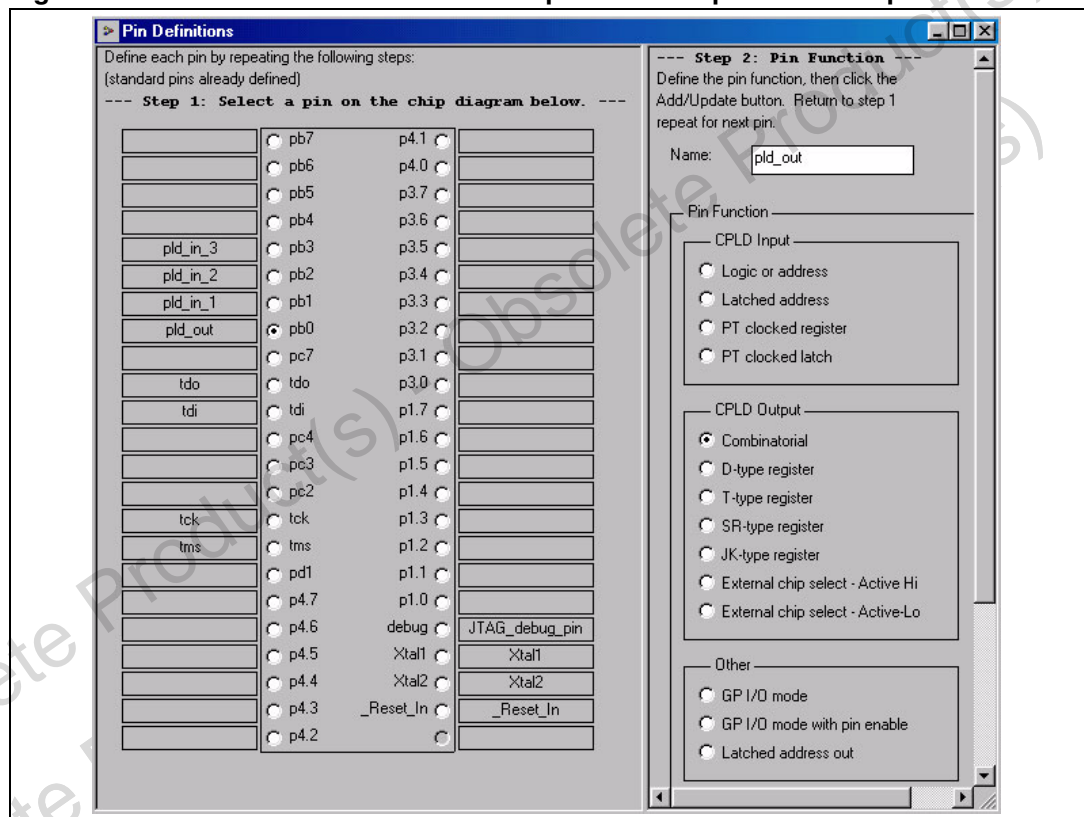
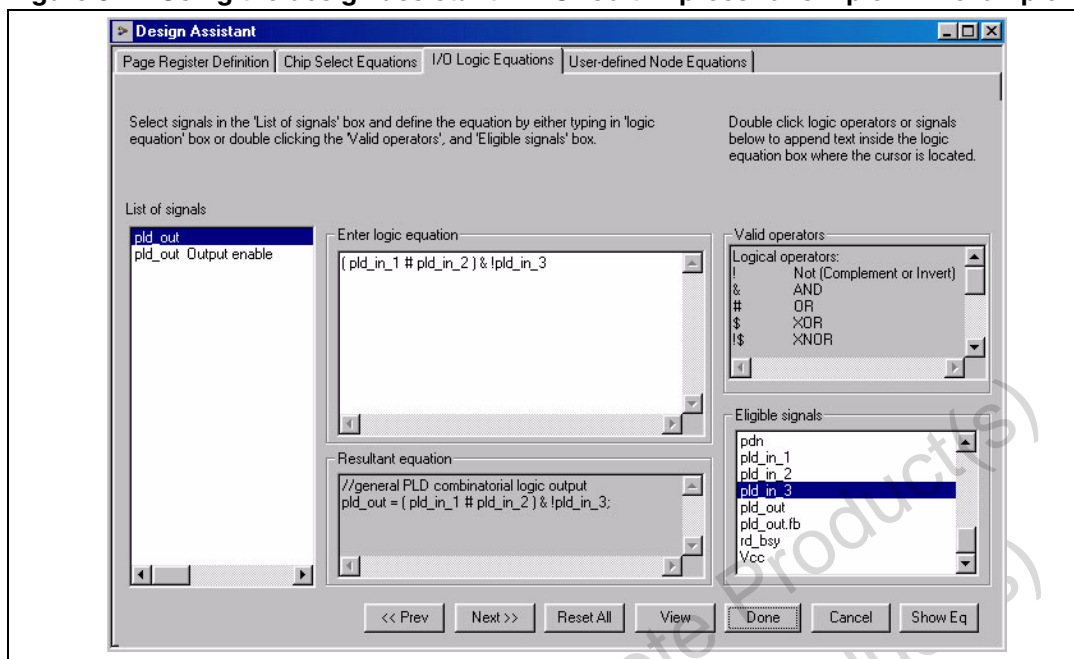

Figure 82. Using the design assistant in PSDsoft Express for simple PLD example



28.5.40 Latched address output mode

In the MCU module, the data bus Bits D0-D15 are multiplexed with the address Bits A0-A15, and the ALE signal is used to separate them with respect to time. Sometimes it is necessary to send de-multiplexed address signals to external peripherals or memory devices. Latched Address Output mode will drive individual demuxed address signals on pins of Ports A or B. Port pins can be designated for this function on a pin-by-pin basis, meaning that an entire port will not be sacrificed if only a few address signals are needed.

To activate this mode, the desired pins on Port A or Port B are designated as “Latched Address Out” in PSDsoft. Then in the 8032 initialization firmware, a logic ‘1’ is written to the csiop Control register for Port A or Port B in each bit position that corresponds to the pin of the port driving an address signal. [Table 190](#) and [Table 191](#) define the csiop Control register locations and bit assignments.

The latched low address byte A4-A7 is available on both Port A and Port B. The high address byte A8-A15 is available on Port B only. Selection of high or low address byte is specified in PSDsoft Express.

Table 190. Latched address output, port A contro register⁽¹⁾⁽²⁾⁽³⁾(address = csiop + offset 02h)

Bit 7	Bit 6	Bit 5	Bit 4	Bit 3	Bit 2	Bit 1	Bit 0
PA7 (addr A7)	PA6 (addr A6)	PA5 (addr A5)	PA4 (addr A4)	PA3 (addr A3)	PA2 (Addr A2)	PA1 (addr A1)	PA0 (addr A0)

1. Port A not available on 52-pin UPSD34xx devices.
2. For each bit, 1 = drive demuxed 8032 address signal on pin, 0 = pin is default mode, MCU I/O.
3. Default state for register is 00h after reset or power-up.

Table 191. Latched address output, port B contro register^{(1) (2)}(address = csiop + offset 03h)

Bit 7	Bit 6	Bit 5	Bit 4	Bit 3	Bit 2	Bit 1	Bit 0
PB7 (addr A7 or A15)	PB6 (addr A6 or A14)	PB5 (addr A5 or A13)	PB4 (addr A4 or A12)	PB3 (addr A3 or A11)	PB2 (Addr A2 or A10)	PB1 (addr A1 or A9)	PB0 (addr A0 or A8)

1. Default state for register is 00h after reset or power-up.
2. For each bit, 1 = drive demuxed 8032 address signal on pin, 0 = pin is default mode, MCU I/O.

28.5.41 Peripheral I/O mode

This mode will provide a data bus repeater function for the 8032 to interface with external parallel peripherals. The mode is only available on Port A (80-pin devices only) and the data bus signals, D0 - D7, are de-multiplexed (no address A0-A7). When active, this mode behaves like a bidirectional buffer, with the direction automatically controlled by the 8032 \overline{RD} and \overline{WR} signals for a specified address range. The DPLD signals PSEL0 and PSEL1 determine this address range. *Figure 79 on page 232* shows the action of Peripheral I/O mode on the Output Enable logic of the tri-state output driver for a single port pin. *Figure 83 on page 239* illustrates data repeater the operation. To activate this mode, choose the pin function "Peripheral I/O Mode" in PSDsoft Express on any Port A pin (all eight pins of Port A will automatically change to this mode). Next in PSDsoft, specify an address range for the PSELx signals in the "Chip-Select" section of the "Design Assistant". The user can specify an address range for either PSEL0 or PSEL1. Always qualify the PSELx equation with "PSEN is logic '1'" to ensure Peripheral I/O mode is only active during 8032 data cycles, not code cycles. Only one equation is needed since PSELx signals are OR'ed together (*Figure 83*). Then in the 8032 initialization firmware, a logic '1' is written to the csiop VM register, Bit 7 (PIO_EN) as shown in *Table 154 on page 189*. After this, Port A will automatically perform this repeater function whenever the 8032 presents an address (and memory page number, if paging is used) that is within the range specified by PSELx. Once Port A is designated as Peripheral I/O mode in PSDsoft Express, it cannot be used for other functions.

Note: The user can alternatively connect an external parallel peripheral to the standard 8032 AD0-AD7 pins on an 80-pin uPSD device (not Port A), but these pins have multiplexed address and data signals, with a weaker fanout drive capability.

Figure 83. Peripheral I/O mode

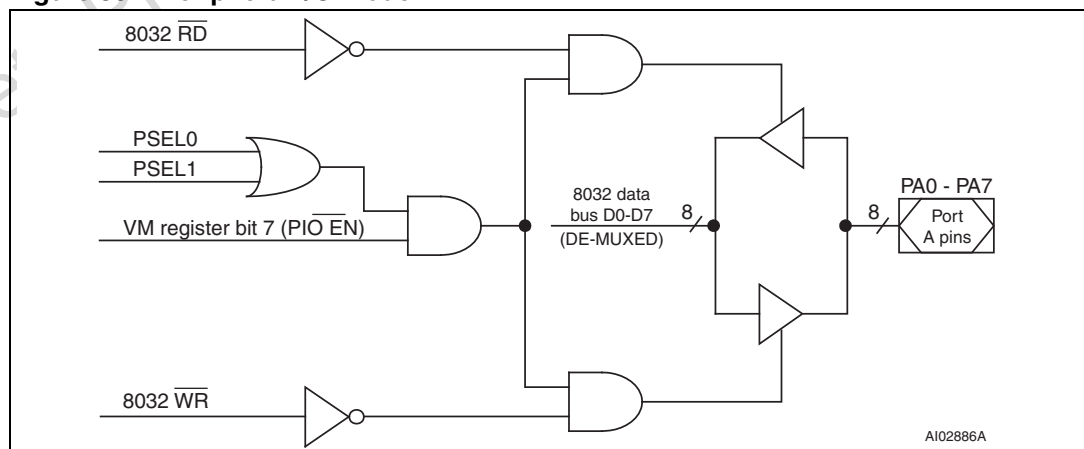

28.5.42 JTAG ISP mode

Four of the pins on Port C are based on the IEEE 1149.1 JTAG specification and are used for In-System Programming (ISP) of the PSD module and debugging of the 8032 MCU module. These pins (TDI, TDO, TMS, TCK) are dedicated to JTAG and cannot be used for any other I/O function. There are two optional pins on Port C (TSTAT and $\overline{\text{TERR}}$) that can be used to reduce programming time during ISP. See [Section 28.6.1: JTAG ISP and JTAG debug on page 257](#).

28.5.43 Other port capabilities

It is possible to change the type of output drive on the ports at run-time. It is also possible to read the state of the output enable signal of the output driver at run-time. The following sections provide the details.

28.5.44 Port pin drive options

The csiop Drive Select registers allow reconfiguration of the output drive type for certain pins on Ports A, B, C, and D. The 8032 can change the default drive type setting at run-time. There is no action needed in PSDsoft Express to change or define these pin output drive types. [Figure 79 on page 232](#) shows the csiop Drive Select register output controlling the pin output driver. The default setting for drive type for all pins on Ports A, B, C, and D is a standard CMOS push-pull output driver.

Note: When a pin on Port A, B, C, D is not used as an output and has no external device driving it as an input (floating pin), excess power consumption can be avoided by placing a weak pull-up resistor ($100\text{K}\Omega$) to V_{DD} which keeps the CMOS input pin from floating.

28.5.45 Drive select registers

The csiop drive select registers will configure a pin output driver as Open Drain or CMOS push/pull for some port pins, and controls the slew rate for other port pins. An external pull-up resistor should be used for pins configured as Open Drain, and the resistor should be sized not to exceed the current sink capability of the pin (see DC specifications). Open Drain outputs are diode clamped, thus the maximum voltage on an pin configured as Open Drain is $V_{DD} + 0.7\text{V}$.

A pin can be configured as Open Drain if its corresponding bit in the drive select register is set to logic '1.'

Note: The slew rate is a measurement of the rise and fall times of an output. A higher slew rate means a faster output response and may create more electrical noise. A pin operates in a high slew rate when the corresponding bit in the drive register is set to '1.' The default rate is standard slew rate (see AC specifications).

[Table 192](#) through [Table 195 on page 242](#) show the csiop drive registers for Ports A, B, C, and D. The tables summarize which pins can be configured as Open Drain outputs and which pins the slew rate can be changed. The default output type is CMOS push/pull output with normal slew rate.

28.5.46 Enable out registers

The state of the output enable signal for the output driver at each pin on Ports A, B, C, and D can be read at any time by the 8032 when it reads the csiop Enable Output registers. Logic '1' means the driver is in output mode, logic '0' means the output driver is in high-impedance

mode, making the pin suitable for input mode (read by the input buffer shown in [Figure 79 on page 232](#)). [Figure 79](#) shows the three sources that can control the pin output enable signal: a product term from AND-OR array; the csiop Direction register; or the Peripheral I/O Mode logic (Port A only). The csiop Enable Out registers represent the state of the final output enable signal for each port pin driver, and are defined in [Table 196 on page 242](#) through [Table 199 on page 242](#).

Table 192. Port A pin drive select register^{(1) (2) (3)}(address = csiop + offset 08h)

Bit 7	Bit 6	Bit 5	Bit 4	Bit 3	Bit 2	Bit 1	Bit 0
PA7 open drain	PA6 open drain	PA5 open drain	PA4 open drain	PA3 slew rate	PA2 slew rate	PA1 slew rate	PA0 slew rate

1. Port A not available on 52-pin UPSD34xx devices.
2. For each bit, 1 = pin drive type is selected, 0 = pin drive type is default mode, CMOS push/pull.
3. Default state for register is 00h after reset or power-up.

Obsolete Product(s) - Obsolete Product(s)

Obsolete Product(s) - Obsolete Product(s)

Table 193. Port B pin drive select register (address = csiop + offset 09h)^{(1) (2)}

Bit 7	Bit 6	Bit 5	Bit 4	Bit 3	Bit 2	Bit 1	Bit 0
PB7 open drain	PB6 open drain	PB5 open drain	PB4 open drain	PB3 slew rate	PB2 slew rate	PB1 slew rate	PB0 slew rate

- For each bit, 1 = pin drive type is selected, 0 = pin drive type is default mode, CMOS push/pull.
- Default state for register is 00h after reset or power-up.

Table 194. Port C pin drive select register (address = csiop + offset 16h)^{(1) (2)}

Bit 7	Bit 6	Bit 5	Bit 4	Bit 3	Bit 2	Bit 1	Bit 0
PC7 open drain	N/A (JTAG)	N/A (JTAG)	PC4 open drain	PC3 open drain	PC2 open drain	N/A (JTAG)	N/A (JTAG)

- For each bit, 1 = pin drive type is selected, 0 = pin drive type is default mode, CMOS push/pull.
- Default state for register is 00h after reset or power-up.

Table 195. Port D pin drive select register (address = csiop + offset 17h)^{(1) (2)}

Bit 7	Bit 6	Bit 5	Bit 4	Bit 3	Bit 2	Bit 1	Bit 0
N/A	N/A	N/A	N/A	N/A	PD2 ⁽³⁾ slew rate	PD1 slew rate	N/A

- For each bit, 1 = pin drive type is selected, 0 = pin drive type is default mode, CMOS push/pull.
- Default state for register is 00h after reset or power-up.
- Pin is not available on 52-pin UPSD34xx devices.

Table 196. Port A enable out register^{(1) (2)} (address = csiop + offset 0Ch)

Bit 7	Bit 6	Bit 5	Bit 4	Bit 3	Bit 2	Bit 1	Bit 0
PA7 OE	PA6 OE	PA5 OE	PA4 OE	PA3 OE	PA2 OE	PA1 OE	PA0 OE

- Port A not available on 52-pin UPSD34xx devices.
- For each bit, 1 = pin drive is enabled as an output, 0 = pin drive is off (high-impedance, pin used as input).

Table 197. Port B enable out register (address = csiop + offset 0Dh)⁽¹⁾

Bit 7	Bit 6	Bit 5	Bit 4	Bit 3	Bit 2	Bit 1	Bit 0
PB7 OE	PB6 OE	PB5 OE	PB4 OE	PB3 OE	PB2 OE	PB1 OE	PB0 OE

- For each bit, 1 = pin drive is enabled as an output, 0 = pin drive is off (high-impedance, pin used as input).

Table 198. Port C enable out register (address = csiop + offset 1Ah)⁽¹⁾

Bit 7	Bit 6	Bit 5	Bit 4	Bit 3	Bit 2	Bit 1	Bit 0
PC7 OE	N/A (JTAG)	N/A (JTAG)	PC4 OE	PC3 OE	PC2 OE	N/A (JTAG)	N/A (JTAG)

- For each bit, 1 = pin drive is enabled as an output, 0 = pin drive is off (high-impedance, pin used as input).

Table 199. Port D enable out register (address = csiop + offset 1Bh)⁽¹⁾

Bit 7	Bit 6	Bit 5	Bit 4	Bit 3	Bit 2	Bit 1	Bit 0
N/A	N/A	N/A	N/A	N/A	PD2 OE ⁽²⁾	PD1 OE	N/A

- For each bit, 1 = pin drive is enabled as an output, 0 = pin drive is off (high-impedance, pin used as input).
- Pin is not available on 52-pin UPSD34xx devices.

28.5.47 Individual port structures

Ports A, B, C, and D have some differences. The structure of each individual port is described in the next sections.

28.5.48 Port A structure

Port A supports the following operating modes:

- MCU I/O Mode
- GPLD Output Mode from Output Macrocells MCELLABx
- GPLD Input Mode to Input Macrocells IMCAx
- Latched Address Output Mode
- Peripheral I/O Mode

Port A also supports Open Drain/Slew Rate output drive type options using csiop Drive Select registers. Pins PA0-PA3 can be configured to fast slew rate, pins PA4-PA7 can be configured to Open Drain Mode.

See [Figure 84](#) for details.

Figure 84. Port A structure

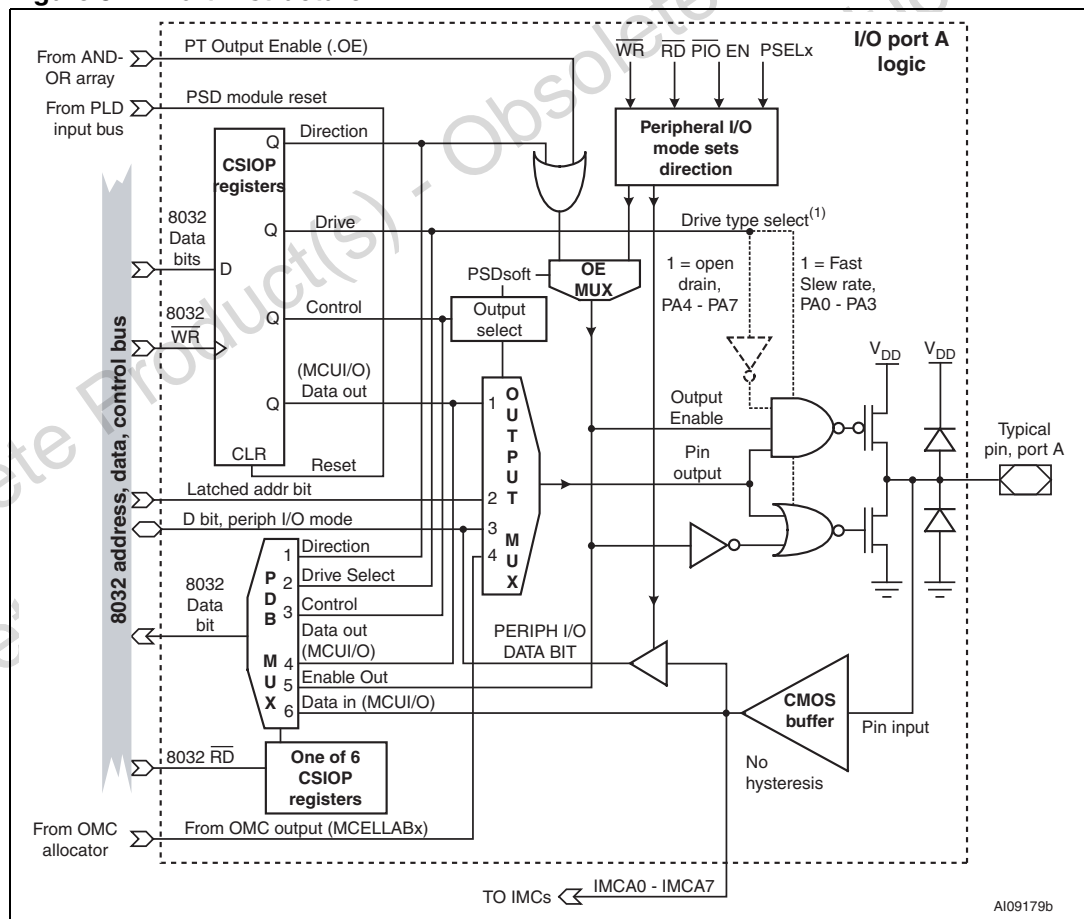

Note: 1 Port pins PA0-PA3 are capable of Fast Slew Rate output drive option. Port pins PA4-PA7 are capable of Open Drain output option.

28.5.49 Port B structure

Port B supports the following operating modes:

- MCU I/O Mode
- GPLD Output Mode from Output Macrocells MCELLABx, or MCELLBCx (OMC allocator routes these signals)
- GPLD Input Mode to Input Macrocells IMCBx
- Latched Address Output Mode

Port B also supports Open Drain/Slew Rate output drive type options using the csiop Drive Select registers. Pins PB0-PB3 can be configured to fast slew rate, pins PB4-PB7 can be configured to Open Drain Mode.

See [Figure 85](#) for detail.

Figure 85. Port B structure

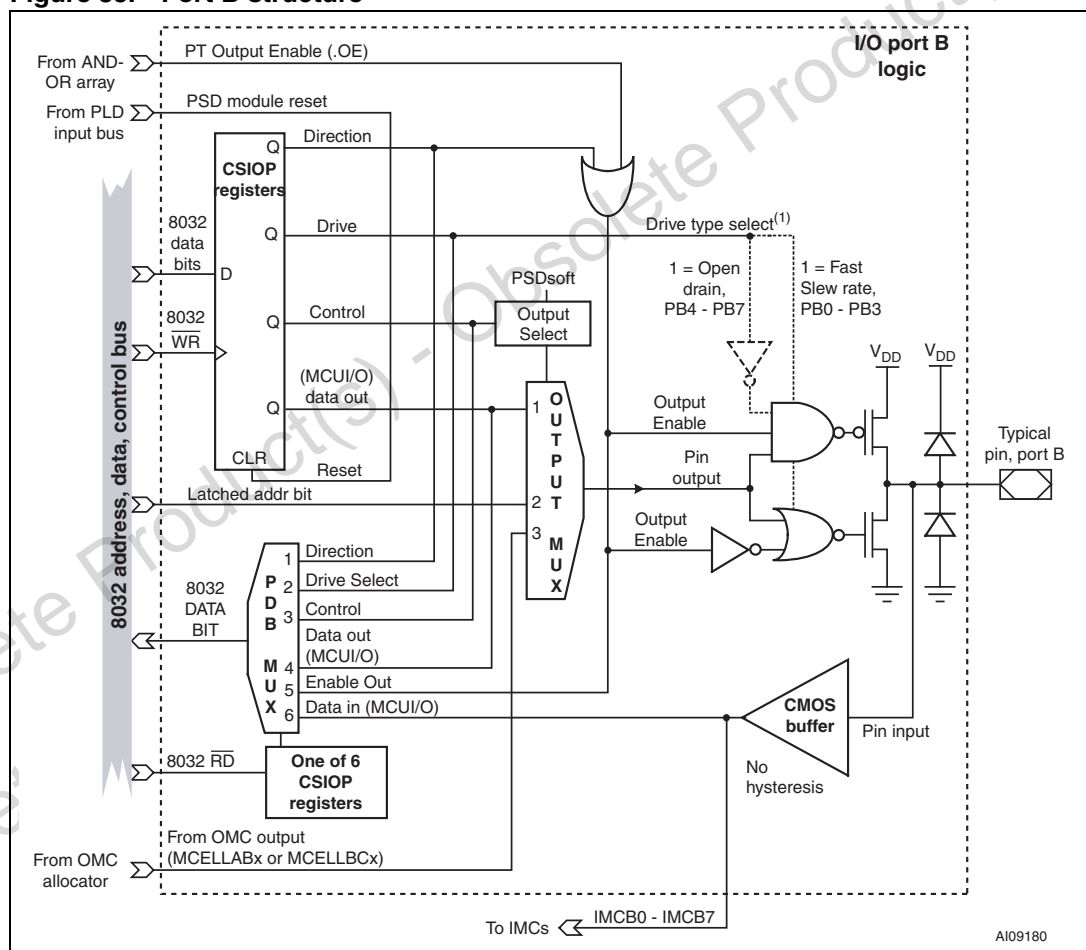

Note: 1 Port pins PB0-PB3 are capable of Fast Slew Rate output drive option. Port pins PB4-PB7 are capable of Open Drain output option.

28.5.50 Port C structure

Port C supports the following operating modes on pins PC2, PC3, PC4, PC7:

- MCU I/O Mode
- GPLD Output Mode from Output Macrocells MCELLBC2, MCELLBC3, MCELLBC4, MCELLBC7
- GPLD Input Mode to Input Macrocells IMCC2, IMCC3, IMCC4, IMCC7

See [Figure 86 on page 246](#) for detail.

Port C pins can also be configured in PSDsoft for other dedicated functions:

- Pins PC3 and PC4 support TSTAT and \overline{TERR} status indicators, to reduce the amount of time required for JTAG ISP programming. These two pins must be used together for this function, adding to the four standard JTAG signals. When TSTAT and \overline{TERR} are used, it is referred to as “6-pin JTAG”. PC3 and PC4 cannot be used for other functions if they are used for 6-pin JTAG. See [Section 28.6.1: JTAG ISP and JTAG debug on page 257](#) for details.
- PC3 can be used as an output to indicate when a Flash memory program or erase operation has completed. This is specified in PSDsoft Express as [Section 28.5.13: Ready/Busy \(PC3\) on page 215](#).

The remaining four pins (TDI, TDO, TCK, TMS) on Port C are dedicated to the JTAG function and cannot be used for any other function. See [Section 28.6.1: JTAG ISP and JTAG debug on page 257](#).

Port C also supports the Open Drain output drive type options on pins PC2, PC3, PC4, and PC7 using the csiop Drive Select registers.

Figure 86. Port C structure

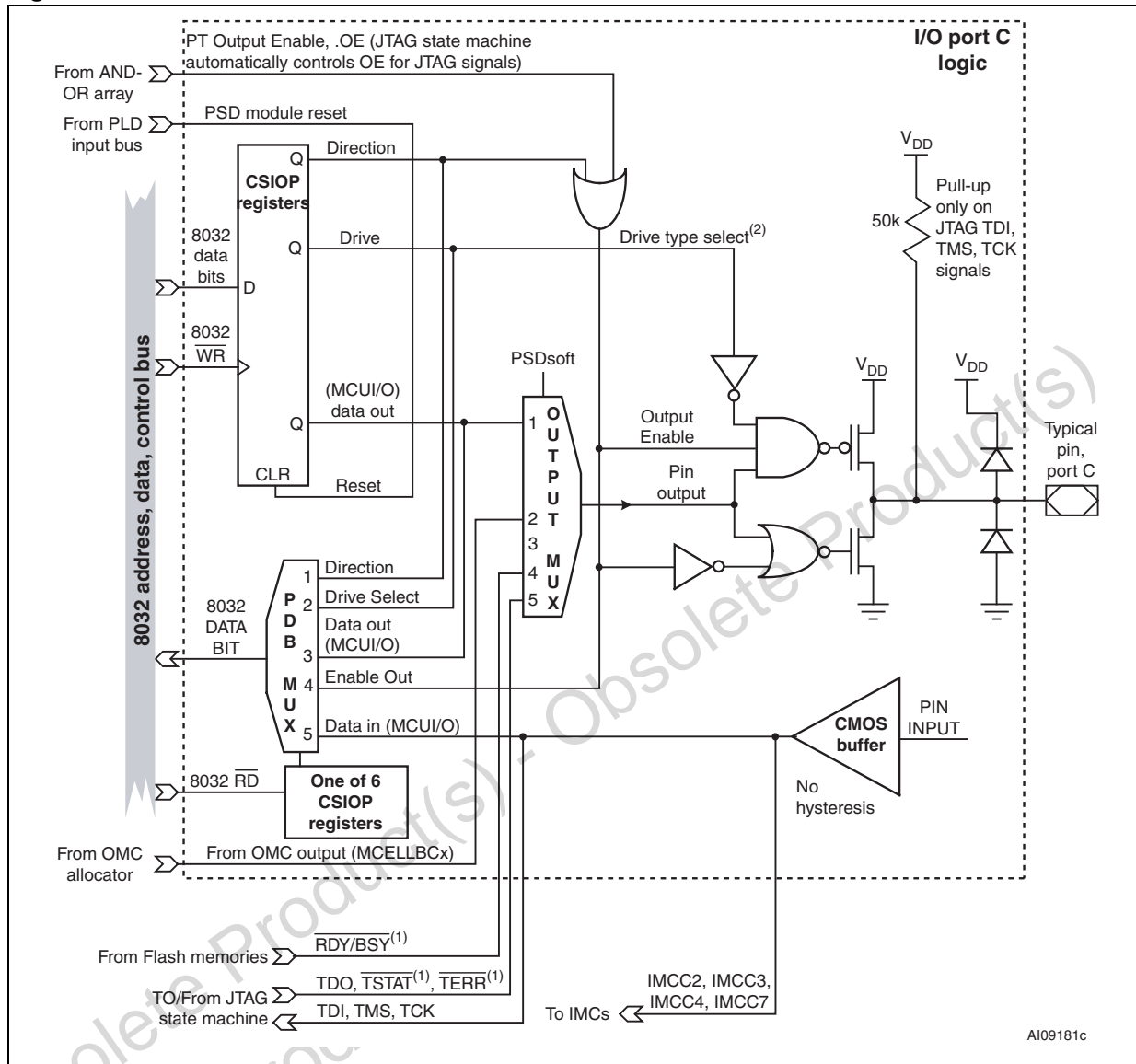

Note: 1 Optional function on a specific Port C pin.

28.5.51 Port D structure

Port D has two I/O pins (PD1, PD2) on 80-pin UPSD34xx devices, and just one pin (PD1) on 52-pin devices, supporting the following operating modes:

- MCU I/O Mode
- DPLD Output Mode for External Chip Selects, ECS1, ECS2. This does not consume OMCs in the GPLD.
- PLD Input Mode – direct input to the PLD Input Bus available to DPLD and GPLD. Does not use IMCs

See [Figure 87 on page 247](#) for detail.

Port D pins can also be configured in PSDsoft as pins for other dedicated functions:

- PD1 can be used as a common clock input to all 16 OMC Flip-flops (see [Section 28.1.11: OMCs on page 195](#)) and also the [Section 28.5.53: Automatic power-down \(APD\) on page 250](#).
- PD2 can be used as a common chip select signal (\overline{CSi}) for the Flash and SRAM memories on the PSD module (see [Section 28.5.55: Chip select input \(CSI\) on page 253](#)). If driven to logic '1' by an external source, \overline{CSi} will force the Flash memory into standby mode regardless of what other internal memory select signals are doing on the PSD module. This is specified in PSDsoft as "PSD Chip Select Input, \overline{CSi} ".

Port D also supports the Fast Slew Rate output drive type option using the csioP Drive Select registers.

Figure 87. Port D structure

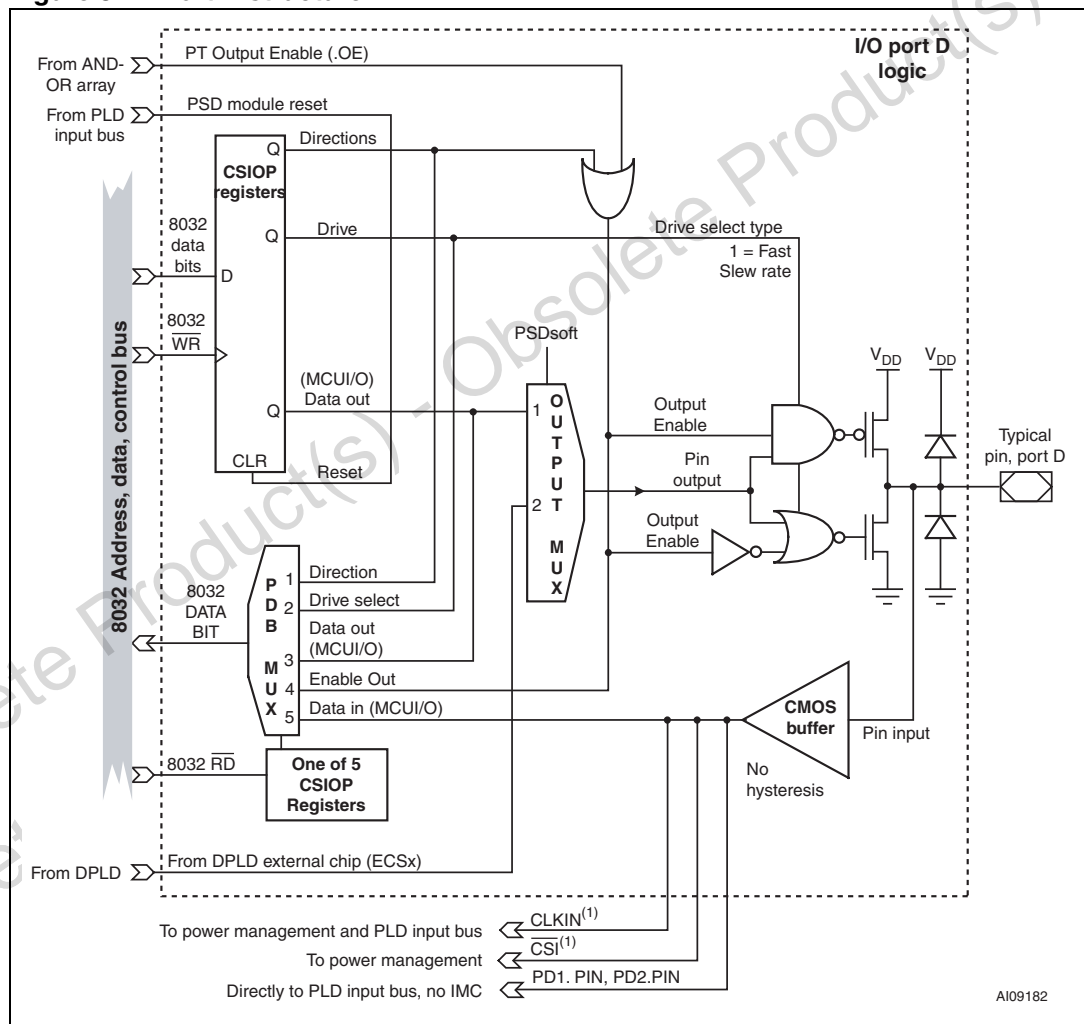

Note: 1 Optional function on a specific Port D pin.

28.5.52 Power management

The PSD module offers configurable power saving options. These options may be used individually or in combinations. A top level description for these functions is given here, then more detailed descriptions will follow.

- **Zero-Power memory:** All memory arrays (Flash and SRAM) in the PSD module are built with zero-power technology. It puts the Flash memory into standby mode (~ zero DC current) when 8032 address signals are not changing. As soon as a transition occurs on any address input, the Flash memory “wakes up”, changes and latches its outputs, then goes back to standby. The designer does not have to do anything special to achieve this memory standby mode when no inputs are changing—it happens automatically. Thus, the slower the 8032 clock, the lower the current consumption. Both PLDs (DPLD and GPLD) are also zero-power, but this is not the default condition. The 8032 must set a bit in one of the csiop PMMR registers at run-time to achieve zero-power.
- **Automatic Power-down (APD):** The APD feature allows the PSD module to reach its lowest current consumption levels. If enabled, the APD counter will time-out when there is a lack of 8032 bus activity for an extended amount of time (8032 asleep). After time-out occurs, all 8032 address and data buffers on the PSD module are shut down, preventing the PSD module memories and potentially the PLDs from waking up from standby, even if address inputs are changing state because of noise or any external components driving the address lines. Since the actual address and data buffers are turned off, current consumption is even further reduced.

Note: Non-address signals are still available to PLD inputs and will wake up the PLDs if these signals are changing state, but will not wake up the memories.

The APD counter requires a relatively slow external clock input on pin PD1 that does stop when the 8032 goes to sleep mode.

- **Forced Power-down (FPD):** The MCU can put the PSD module into Power-Down mode with the same results as using APD described above, but FPD does not rely on the APD counter. Instead, FPD will force the PSD module into Power-Down mode when the MCU firmware sets a bit in one of the csiop PMMR registers. This is a good alternative to APD because no external clock is needed for the APD counter.
- **PSD module Chip Select input ($\overline{\text{CSI}}$):** This input on pin PD2 (80-pin devices only) can be used to disable the internal Flash memory, placing it in standby mode even if address inputs are changing. This feature does not block any internal signals (the address and data buffers are still on but signals are ignored) and $\overline{\text{CSI}}$ does not disable the PLDs. This is a good alternative to using the APD counter, which requires an external clock on pin PD1.
- **Non-Turbo mode:** The PLDs can operate in Turbo or non-Turbo modes. Turbo mode has the shortest signal propagation delay, but consumes more current than non-Turbo mode. A csiop register can be written by the 8032 to select modes, the default mode is with Turbo mode enabled. In non-Turbo mode, the PLDs can achieve very low standby current (~ zero DC current) while no PLD inputs are changing, and the PLDs will even use less AC current when inputs do change compared to Turbo mode.

When the Turbo mode is enabled, there is a significant DC current component AND the AC current component is higher than non-Turbo mode, as shown in [Figure 95 on page 265](#) (5 V) and [Figure 96 on page 266](#) (3.3 V).

- **Blocking bits:** Significant power savings can be achieved by blocking 8032 bus control signals (RD, WR, PSEN, ALE) from reaching PLD inputs, if these signals are not used in any PLD equations. Blocking is achieved by the 8032 writing to the “blocking bits” in

csiop PMMR registers. Current consumption of the PLDs is directly related to the composite frequency of all transitions on PLD inputs, so blocking certain PLD inputs can significantly lower PLD operating frequency and power consumption (resulting in a lower frequency on the graphs of [Figure 95 on page 265](#) and [Figure 96 on page 266](#)).

Note: It is recommended to prevent unused inputs from floating on Ports A, B, C, and D by pulling them up to V_{DD} with a weak external resistor (100K Ω), or by setting the csiop Direction register to “output” at run-time for all unused inputs. This will prevent the CMOS input buffers of unused input pins from drawing excessive current.

The csiop PMMR register definitions are shown in [Table 200](#) through [Table 202 on page 250](#).

Table 200. Power management mode register PMMR0 (address = csiop + offset B0h)⁽¹⁾

Bit 0	X	0	Not used, and should be set to zero.
Bit 1	APD Enable	0	Automatic Power Down (APD) counter is disabled.
		1	APD counter is enabled
Bit 2	X	0	Not used, and should be set to zero.
Bit 3	PLD Turbo Disable	0 = on	PLD Turbo mode is on
		1 = off	PLD Turbo mode is off, saving power.
Bit 4	Blocking Bit, CLKIN to PLDs ⁽²⁾	0 = on	CLKIN (pin PD1) to the PLD Input Bus is not blocked. Every transition of CLKIN powers-up the PLDs.
		1 = off	CLKIN input to PLD Input Bus is blocked, saving power. But CLKIN still goes to APD counter.
Bit 5	Blocking Bit, CLKIN to OMCs Only ⁽²⁾	0 = on	CLKIN input is not blocked from reaching all OMCs' common clock inputs.
		1 = off	CLKIN input to common clock of all OMCs is blocked, saving power. But CLKIN still goes to APD counter and all PLD logic besides the common clock input on OMCs.
Bit 6	X	0	Not used, and should be set to zero.
Bit 7	X	0	Not used, and should be set to zero.

1. All the bits of this register are cleared to zero following power-up. Subsequent Reset (\overline{RST}) pulses do not clear the registers.

2. Blocking bits should be set to logic '1' only if the signal is not needed in a DPLD or GPLD logic equation.

Table 201. Power management mode register PMMR2 (address = csiop + offset B4h)⁽¹⁾

Bit 0	X	0	Not used, and should be set to zero.
Bit 1	X	0	Not used, and should be set to zero.
Bit 2	Blocking Bit, \overline{WR} to PLDs ⁽²⁾	0 = on	8032 \overline{WR} input to the PLD Input Bus is not blocked.
		1 = off	8032 \overline{WR} input to PLD Input Bus is blocked, saving power.

Table 201. Power management mode register PMMR2 (address = csiop + offset B4h)⁽¹⁾ (continued)

Bit 3	Blocking Bit, \overline{RD} to PLDs ⁽²⁾	0 = on	8032 \overline{RD} input to the PLD Input Bus is not blocked.
		1 = off	8032 \overline{RD} input to PLD Input Bus is blocked, saving power.
Bit 4	Blocking Bit, \overline{PSEN} to PLDs ⁽²⁾	0 = on	8032 \overline{PSEN} input to the PLD Input Bus is not blocked.
		1 = off	8032 \overline{PSEN} input to PLD Input Bus is blocked, saving power.
Bit 5	Blocking Bit, ALE to PLDs ⁽²⁾	0 = on	8032 ALE input to the PLD Input Bus is not blocked.
		1 = off	8032 ALE input to PLD Input Bus is blocked, saving power.
Bit 5	Blocking Bit, PC7 to PLDs ⁽²⁾	0 = on	Pin PC7 input to the PLD Input Bus is not blocked.
		1 = off	Pin PC7 input to PLD Input Bus is blocked, saving power.
Bit 7	X	0	Not used, and should be set to zero.

1. All the bits of this register are cleared to zero following power-up. Subsequent Reset (\overline{RST}) pulses do not clear the registers.
2. Blocking bits should be set to logic '1' only if the signal is not needed in a DPLD or GPLD logic equation.

Table 202. Power management mode register PMMR3 (address = csiop + offset C7h)⁽¹⁾

Bit 0	X	0	Not used, and should be set to zero.
Bit 1	FORCE_PD	0 = off	APD counter will cause Power-Down Mode if APD is enabled.
		1 = on	Power-Down mode will be entered immediately regardless of APD activity.
Bit 3-7	X	0	Not used, and should be set to zero.

1. All the bits of this register are cleared to zero following power-up. Subsequent Reset (\overline{RST}) pulses do not clear the registers.

28.5.53 Automatic power-down (APD)

The APD unit shown in [Figure 73 on page 221](#) puts the PSD module into power-down mode by monitoring the activity of the 8032 Address Latch Enable (ALE) signal. If the APD unit is enabled by writing a logic '1' to Bit 1 of the csiop PMMR0 register, and if ALE signal activity has stopped (8032 in sleep mode), then the four-bit APD counter starts counting up. If the ALE signal remains inactive for 15 clock periods of the CLKIN signal (pin PD1), then the APD counter will reach maximum count and the power down indicator signal (PDN) goes to logic '1' forcing the PSD module into power-down mode. During this time, all buffers on the PSD module for 8032 address and data signals are disabled in silicon, preventing the PSD module Flash memories from waking up from standby mode, even if noise or other devices

are driving the address lines. The PLDs will also stay in standby mode if the PLDs are in non-Turbo mode and if all other PLD inputs (non-address signals) are static.

However, if the ALE signal has a transition before the APD counter reaches max count, the APD counter is cleared to zero and the PDN signal will not go active, preventing power-down mode. To prevent unwanted APD time-outs during normal 8032 operation (not sleeping), it is important to choose a clock frequency for CLKIN that will NOT produce 15 or more pulses within the longest period between ALE transitions. A 32768 Hz clock signal is quite often an ideal frequency for CLKIN and APD, and this frequency is often available on external supervisor or real-time clock devices.

The “PDN” power-down indicator signal is available to the PLD input bus to use in any PLD equations if desired. The user may want to send this signal as a PLD output to an external device to indicate the PSD module is in power-down mode. PSDsoft Express automatically includes the “PDN” signal in the DPLD chip select equations for FSx, CSBOOTx, RS0, and CSIOP.

The following should be kept in mind when the PSD module is in power-down mode:

- 8032 address and data bus signals are blocked from all memories and both PLDs.
- The PSD module comes out of power-down mode when: ALE starts pulsing again, or the \overline{CS} input on pin PD2 transitions from logic '1' to logic '0,' or the PSD module reset signal, \overline{RST} , transitions from logic '0' to logic '1.'
- Various signals can be blocked (prior to power-down mode) from entering the PLDs by using “blocking bits” in csiop PMMR registers.
- The Flash memory enters standby mode, and the state of the PLDs and I/O Ports are unchanged (if no PLD inputs change). [Table 203 on page 256](#) shows the effects of power-down mode on I/O pins while in various operating modes.
- The 8032 Ports 1,3, and 4 on the MCU module are not affected at all by power-down mode in the PSD module.
- Power-down standby current given in the AC specifications for PSD module assume there are no transitions on any unblocked PLD input, and there are no output pins driving any loads.

The APD counter will count whenever Bit 1 of csiop PMMR0 register is set to logic '1,' and when the ALE signal is steady at either logic '1' or logic '0' (not transitioning). [Figure 89 on page 253](#) shows the flow leading up to power-down mode. The only action required in PSDsoft Express to enable APD mode is to select the pin function “Common Clock Input, CLKIN” before programming with JTAG.

28.5.54 Forced power-down (FDP)

An alternative to APD is FDP. The resulting power-savings is the same, but the PDN signal in [Figure 88 on page 252](#) is set and Power-Down mode is entered immediately when firmware sets the FORCE_PD Bit to logic '1' in the csiop register PMMR3 (Bit 1). FDP will override APD counter activity when FORCE_PD is set. No external clock source for the APD counter is needed. The FORCE_PD Bit is cleared only by a reset condition.

Caution must be used when implementing FDP because code memory goes off-line as soon as PSD module Power-Down mode is entered, leaving the MCU with no instruction stream to execute.

The MCU module must put itself into Power-Down mode after it puts the PSD module into Power-Down Mode. How can it do this if code memory goes off-line? The answer is the Pre-Fetch Queue (PFQ) in the MCU module. By using the instruction scheme shown in the 8051

assembly code example in [Table](#) , the PFQ will be loaded with the final instructions to command the MCU module to Power Down mode after the PDS Module goes to Power-Down mode. In this case, even though the code memory goes off-line in the PSD module, the last few MCU instruction are sourced from the PFQ.

Forced power-down example

```

PDOWN:  ANL      A8h, #7Fh    ; disable all interrupts
        ORL      9Dh, #C0h    ; ensure PFQ and BC are enabled
        MOV      DPTR, #xxC7  ; load XDATA pointer to select PMMR3 register (xx = base
                                ; address of csiop registers)

        CLR      A            ; clear A
        JMP      LOOP        ; first loop - fill PFQ/BQ with Power Down instructions
        NOP          ; second loop - fetch code from PFQ/BC and set Power-
                                ; Down bits for PSD module and then MCU module

LOOP:    MOVX     @DPTR, A    ; set FORCE_PD Bit in PMMR3 in PSD module in second
                                ; loop
        MOV      87h, A      ; set PD Bit in PCON register in MCU module in second
                                ; loop
        MOV      A, #02h     ; set power-down bit in the A register, but not in PMMR3 or
                                ; PCON yet in first loop
        JMP      LOOP        ; uPSD enters into Power-Down mode in second loop
    
```

Figure 88. Automatic power-down (APD) unit

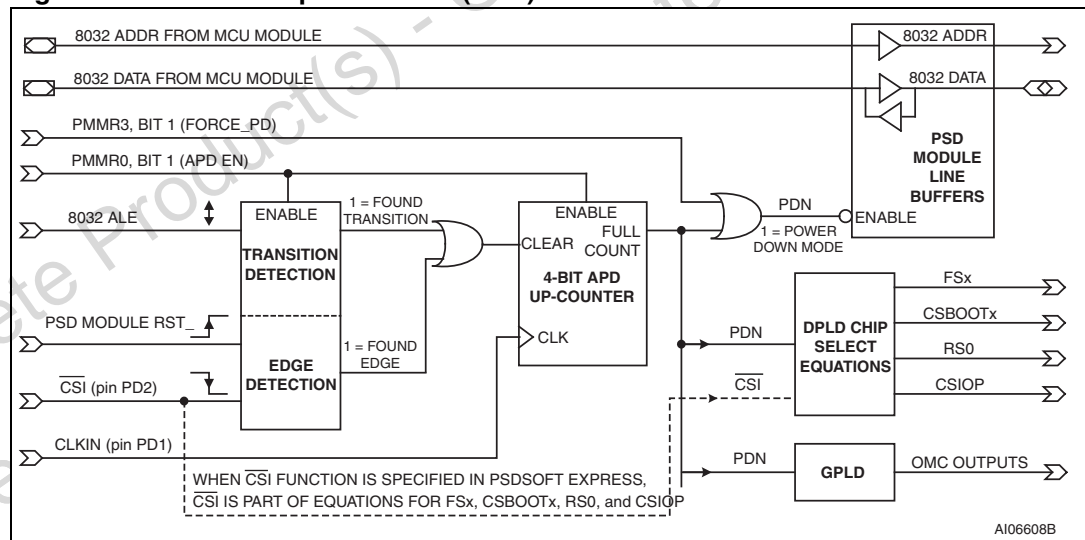
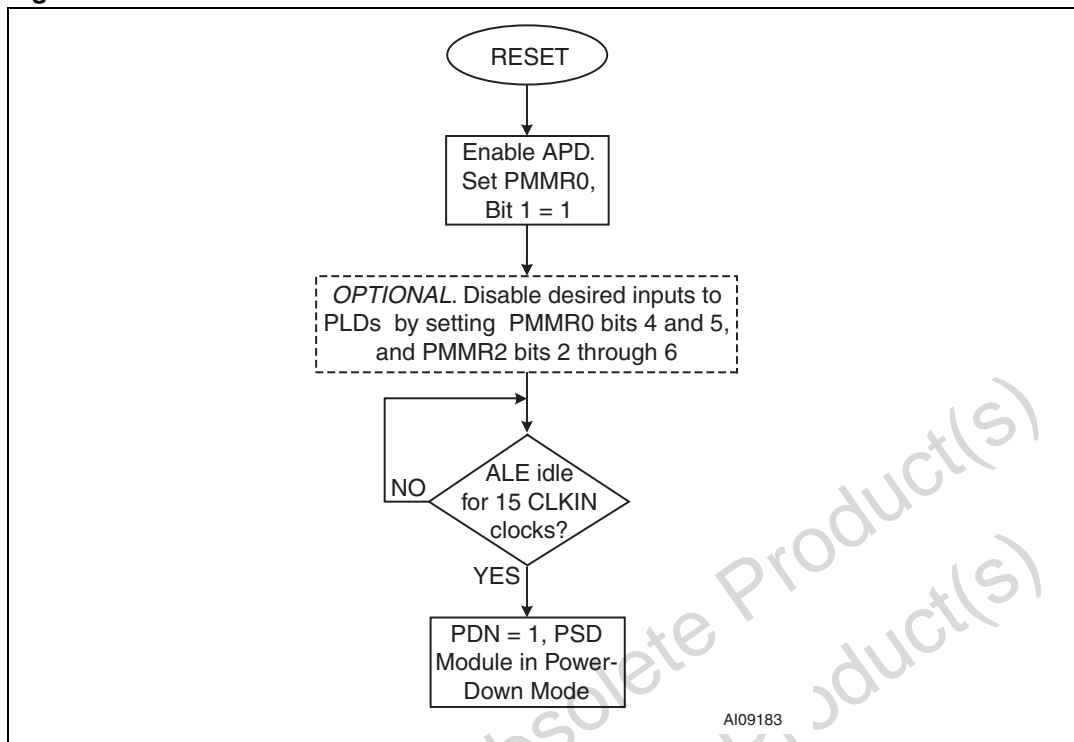

Figure 89. Power-down mode flowchart



28.5.55 Chip select input (\overline{CS})

Pin PD2 of Port D can optionally be configured in PSDsoft Express as the PSD module Chip Select Input, \overline{CS} , which is an active-low logic input. By default, pin PD2 does not have the \overline{CS} function.

When the \overline{CS} function is specified in PSDsoft Express, the \overline{CS} signal is automatically included in DPLD chip select equations for FSx, CSBOOTx, RS0, and CSIOP. When the \overline{CS} pin is driven to logic '0' from an external device, all of these memories will be available for READ and WRITE operations. When \overline{CS} is driven to logic '1,' none of these memories are available for selection, regardless of the address activity from the 8032, reducing power consumption. The state of the PLD and port I/O pins are not changed when \overline{CS} goes to logic '1' (disabled).

28.5.56 PLD non-turbo mode

The power consumption and speed of the PLDs are controlled by the Turbo Bit (Bit 3) in the csiop PMMR0 register. By setting this bit to logic '1,' the Turbo mode is turned off and both PLDs consume only standby current when ALL PLD inputs have no transitions for an extended time (65 ns for 5 V devices, 100 ns for 3.3 V devices), significantly reducing current consumption. The PLDs will latch their outputs and go to standby, drawing very little current. When Turbo mode is off, PLD propagation delay time is increased as shown in the AC specifications for the PSD module. Since this additional propagation delay also effects the DPLD, the response time of the memories on the PSD module is also lengthened by that same amount of time. If Turbo mode is off, the user should add an additional wait state to the 8032 BUSCON SFR register if the 8032 clock frequency is higher that a particular value. Please refer to [Table 51 on page 90](#) in the MCU module section.

The default state of the Turbo Bit is logic '0,' meaning Turbo mode is on by default (after power-up and reset conditions) until it is turned off by the 8032 writing to PMMR0.

28.5.57 PLD current consumption

Figure 95 on page 265 and *Figure 96 on page 266* (5 V and 3.3 V devices respectively) show the relationship between PLD current consumption and the composite frequency of all the transitions on PLD inputs, indicating that a higher input frequency results in higher current consumption.

Current consumption of the PLDs have a DC component and an AC component. Both need to be considered when calculating current consumption for a specific PLD design. When Turbo mode is on, there is a linear relationship between current and frequency, and there is a substantial DC current component consumed by the PSD module when there are no transitions on PLD inputs (composite frequency is zero). The magnitude of this DC current component is directly proportional to how many product terms are used in the equations of both PLDs. PSDsoft Express generates a “fitter” report that specifies how many product terms were used in a design out of a total of 186 available product terms. *Figure 95 on page 265* and *Figure 96 on page 266* both give two examples, one with 100% of the 186 product terms used, and another with 25% of the 186 product terms used.

28.5.58 Turbo mode current consumption

To determine the AC current component of the specific PLD design with Turbo mode on, the user will have to interpolate from the graph, given the number of product terms specified in the fitter report, and the estimated composite frequency of PLD input signal transitions. For the DC component (y-axis crossing), the user can calculate the number by multiplying the number of product terms used (from fitter report) times the DC current per product term specified in the DC specifications for the PSD module. The total PLD current usage is the sum of its AC and DC components.

28.5.59 Non-turbo mode current consumption

Notice in *Figure 95 on page 265* and *Figure 96 on page 266* that when Turbo mode is off, the DC current consumption is “zero” (just standby current) when the composite frequency of PLD input transitions is zero (no input transitions). Now moving up the frequency axis to consider the AC current component, current consumption remains considerably less than Turbo mode until PLD input transitions happen so rapidly that the PLDs do not have time to latch their outputs and go to standby between the transitions anymore. This is where the lines converge on the graphs, and current consumption becomes the same for PLD input transitions at this frequency and higher regardless if Turbo mode is on or off. To determine the current consumption of the PLDs with Turbo mode off, extrapolate the AC component from the graph based on number of product terms and input frequency. The only DC component in non-Turbo mode is the PSD module standby current.

The key to reducing PLD current consumption is to reduce the composite frequency of transitions on the PLD input bus, moving down the frequency scale on the graphs. One way to do this is to carefully select which signals are entering PLD inputs, not selecting high frequency signals if they are not used in PLD equations. Another way is to use PLD “Blocking Bits” to block certain signals from entering the PLD input bus.

28.5.60 PLD blocking bits

Blocking specific signals from entering the PLDs using bits of the csiop PMMR registers can further reduce PLD AC current consumption by lowering the effective composite frequency of inputs to the PLDs.

28.5.61 Blocking 8032 bus control signals

When the 8032 is active on the MCU module, four bus control signals (\overline{RD} , \overline{WR} , \overline{PSEN} , and ALE) are constantly transitioning to manage 8032 bus traffic. Each time one of these signals has a transition from logic '1' to '0,' or 0 to '1,' it will wake up the PLDs if operating in non-Turbo mode, or when in Turbo mode it will cause the affected PLD gates to draw current. If equations in the DPLD or GPLD do not use the signals \overline{RD} , \overline{WR} , \overline{PSEN} , or ALE then these signals can be blocked which will reduce the AC current component substantially. These bus control signals are rarely used in DPLD equations because they are routed in silicon directly to the memory arrays of the PSD module, bypassing the PLDs. For example, it is NOT necessary to qualify a memory chip select signal with an MCU write strobe, such as "fs0 = address range & !WR_". Only "fs0 = address range" is needed.

Each of the 8032 bus control signals may be blocked individually by writing to Bits 2, 3, 4, and 5 of the PMMR2 register shown in [Table 201 on page 249](#). Blocking any of these four bus control signals only prevents them from reaching the PLDs, but they will always go to the memories directly.

However, sometimes it is necessary to use these 8032 bus control signals in the GPLD when creating interface signals to external I/O peripherals. But it is still possible to save power by dynamically unblocking the bus signals before reading/writing the external device, then blocking the signals after the communication is complete.

The user can also block an input signal coming from pin PC7 to the PLD input bus if desired by writing to Bit 6 of PMMR2.

28.5.62 Blocking common clock, CLKIN

The input CLKIN (from pin PD1) can be blocked to reduce current consumption. CLKIN is used as a common clock input to all OMC flip-flops, it is a general input to the PLD input bus, and it is used to clock the APD counter. In PSDsoft Express, the function of pin PD1 must be specified as "Common Clock Input, CLKIN" before programming the device with JTAG to get the CLKIN function.

Bit 4 of PMMR0 can be set to logic '1' to block CLKIN from reaching the PLD input bus, but CLKIN will still reach the APD counter.

Bit 5 of PMMR0 can be set to logic '1' to block CLKIN from reaching the OMC flip-flops only, but CLKIN is still available to the PLD input bus and the APD counter.

See [Table 200 on page 249](#) for details.

28.6 PSD module reset conditions

The PSD module receives a reset signal from the MCU module. This reset signal is referred to as the "RST" input in PSD module documentation, and it is active-low when asserted. The character of the RST signal generated from the MCU module is described in [Section 19: Supervisory functions on page 91](#).

Upon power-up, and while $\overline{\text{RST}}$ is asserted, the PSD module immediately loads its configuration from non-volatile bits to configure the PLDs and other items. PLD logic is operational and ready for use well before $\overline{\text{RST}}$ is de-asserted. The state of PLD outputs are determined by equations specified in PSDsoft Express.

The Flash memories are reset to Read Array mode after any assertion of $\overline{\text{RST}}$ (even if a program or erase operation is occurring).

Flash memory WRITE operations are automatically prevented while V_{DD} is ramping up until it rises above the V_{LKO} voltage threshold at which time Flash memory WRITE operations are allowed.

Once the UPSD34xx is up and running, any subsequent reset operation is referred to as a warm reset, until power is turned off again. Some PSD module functions are reset in different ways depending if the reset condition was caused from a power-up reset or a warm reset. [Table 203 on page 256](#) summarizes how PSD module functions are affected by power-up and warm resets, as well as the affect of PSD module power-down mode (from APD).

The I/O pins of PSD module Ports A, B, C, and D do not have weak internal pull-ups.

In MCU I/O mode, Latched Address Out mode, and Peripheral I/O mode, the pins of Ports A, B, C, and D become standard CMOS inputs during a reset condition. If no external devices are driving these pins during reset, then these inputs may float and draw excessive current. If low power consumption is critical during reset, then these floating inputs should be pulled up externally to V_{DD} with a weak (100K Ω minimum) resistor.

In PLD I/O mode, pins of Ports A, B, C, and D may also float during reset if no external device is driving them, and if there is no equation specified for the DPLD or GPLD to make them an output. In this case, a weak external pull-up resistor (100K Ω minimum) should be used on floating pins to avoid excessive current draw.

The pins on Ports 1, 3, and 4 of the 8032 MCU module do have weak internal pull-ups and the inputs will not float, so no external pull-ups are needed.

Table 203. Function status during power-up reset, warm reset, power-down mode

Port configuration or register	Power-up reset	Warm reset	APD Power-down mode
MCU I/O	Pins are in input mode	Pins are in input mode	Pin logic state is unchanged
PLD I/O	Pin logic is valid after internal PSD module configuration bits are loaded. Happens long before $\overline{\text{RST}}$ is de-asserted	Pin logic is valid and is determined by PLD logic equations	Pin logic depends on inputs to PLD (8032 addresses are blocked from reaching PLD inputs during power-down mode)
Latched address out mode	Pins are High Impedance	Pins are high impedance	Pins logic state not defined since 8032 address signals are blocked
Peripheral I/O mode	Pins are High Impedance	Pins are High Impedance	Pins are High Impedance
JTAG ISP and debug	JTAG channel is active and available	JTAG channel is active and available	JTAG channel is active and available
PMMR0 and PMMR2	Cleared to 00h	Unchanged	Unchanged
Output of OMC Flip-flops	Cleared to '0'	Depends on .re and .pr equations	Depends on .re and .pr equations

Table 203. Function status during power-up reset, warm reset, power-down mode (continued)

Port configuration or register	Power-up reset	Warm reset	APD Power-down mode
VM register ⁽¹⁾	Initialized with value that was specified in PSDsoft	Initialized with value that was specified in PSDsoft	Unchanged
All other csiop registers	Cleared to 00h	Cleared to 00h	Unchanged

1. VM register Bit 7 (PIO_EN) and Bit 0 (SRAM in 8032 program space) are cleared to zero at power-up and warm reset conditions.

28.6.1 JTAG ISP and JTAG debug

An IEEE 1149.1 serial JTAG interface is used on UPSD34xx devices for ISP (in-system programming) of the PSD module, and also for debugging firmware on the MCU module. IEEE 1149.1 Boundary Scan operations are not supported in the UPSD34xx.

The main advantage of JTAG ISP is that a blank UPSD34xx device may be soldered to a circuit board and programmed with no involvement of the 8032, meaning that no 8032 firmware needs to be present for ISP. This is good for manufacturing, for field updates, and for easy code development in the lab. JTAG-based programmers and debuggers for UPSD34xx are available from STMicroelectronics and 3rd party vendors.

ISP is different than IAP (in-application programming). IAP involves the 8032 to program Flash memory over any interface supported by the 8032 (e.g., UART, SPI, I2C), which is good for remote updates over a communication channel. UPSD34xx devices support both ISP and IAP. The entire PSD module (Flash memory and PLD) may be programmed with JTAG ISP, but only the Flash memories may be programmed using IAP.

28.6.2 JTAG chaining inside the package

JTAG protocol allows serial “chaining” of more than one device in a JTAG chain. The UPSD34xx is assembled with a stacked die process combining the PSD module (one die) and the MCU module (the other die). These two die are chained together within the UPSD34xx package. The standard JTAG interface has four basic signals:

- TDI - Serial data into device
- TDO - Serial data out of device
- TCK - Common clock
- TMS - Mode Selection

Every device that supports IEEE 1149.1 JTAG communication contains a test access port (TAP) controller, which is a small state machine to manage JTAG protocol and serial streams of commands and data. Both the PSD module and the MCU module each contain a TAP controller.

Figure 90 illustrates how these die are chained within a package. JTAG programming/test equipment will connect externally to the four IEEE 1149.1 JTAG pins on Port C. The TDI pin on the UPSD34xx package goes directly to the PSD module first, then exits the PSD module through TDO. TDO of the PSD module is connected to TDI of the MCU module. The serial path is completed when TDO of the MCU module exits the UPSD34xx package through the TDO pin on Port C. The JTAG signals TCK and TMS are common to both modules as specified in IEEE 1149.1. When JTAG devices are chained, typically one device is in BYPASS mode while another device is executing a JTAG operation. For the UPSD34xx, the

PSD module is in BYPASS mode while debugging the MCU module, and the MCU module is in BYPASS mode while performing ISP on the PSD module.

The $\overline{\text{RESET_IN}}$ input pin on the UPSD34xx package goes to the MCU module, and this module will generate the $\overline{\text{RST}}$ reset signal for the PSD module. These reset signals are totally independent of the JTAG TAP controllers, meaning that the JTAG channel is operational when the modules are held in reset. It is required to assert $\overline{\text{RESET_IN}}$ during ISP. STMicroelectronics and 3rd party JTAG ISP tools will automatically assert a reset signal during ISP. However, the user must connect this reset signal to $\overline{\text{RESET_IN}}$ as shown in examples in [Figure 91 on page 259](#) and [Figure 92 on page 261](#).

Figure 90. JTAG chain in UPSD34xx package

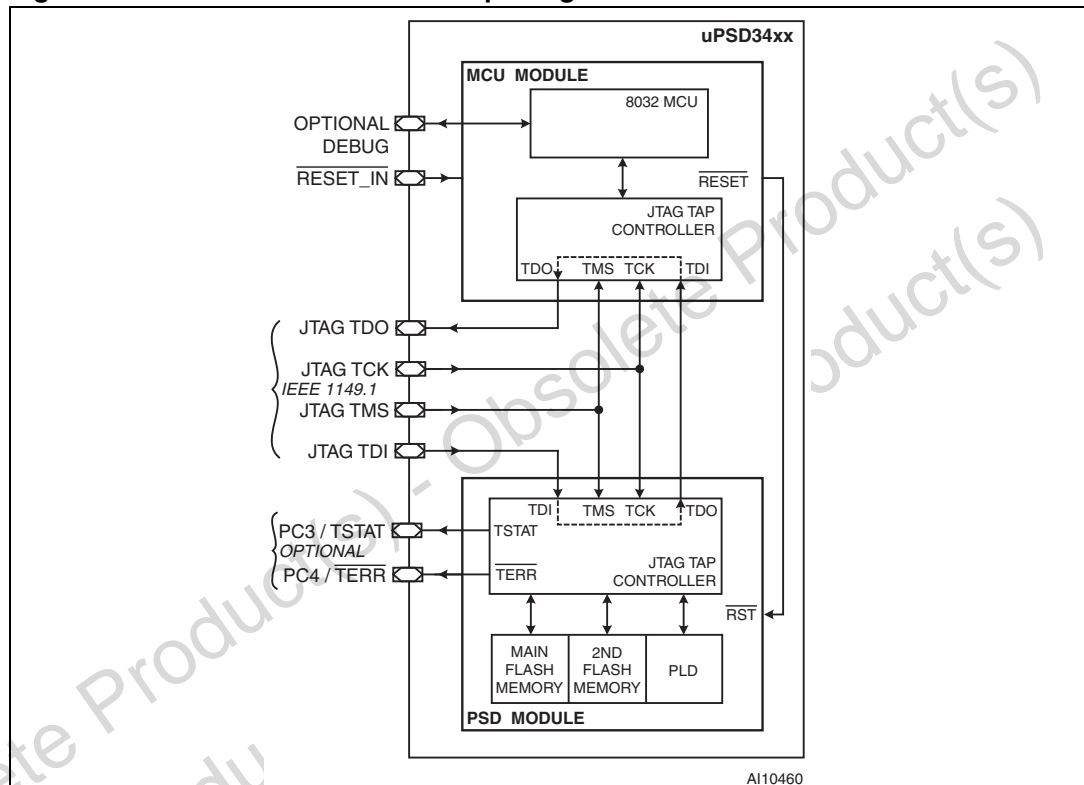

28.6.3 In-system programming

The ISP function can use two different configurations of the JTAG interface:

- 4-pin JTAG: TDI, TDO, TCK, TMS
- 6-pin JTAG: Signals above plus TSTAT, $\overline{\text{TERR}}$

At power-up, the four basic JTAG signals are all inputs, waiting for a command to appear on the JTAG bus from programming or test equipment. When the enabling command is received, TDO becomes an output and the JTAG channel is fully functional. The same command that enables the JTAG channel may optionally enable the two additional signals, TSTAT and $\overline{\text{TERR}}$.

28.6.4 4-pin JTAG ISP (default)

The four basic JTAG pins on Port C are enabled for JTAG operation at all times. These pins may not be used for other I/O functions. There is no action needed in PSDsoft Express to configure a device to use 4-pin JTAG, as this is the default condition. No 8032 firmware is needed to use 4-pin ISP because all ISP functions are controlled from the external JTAG program/test equipment. *Figure 91* shows recommended connections on a circuit board to a JTAG program/test tool using 4-pin JTAG. It is required to connect the \overline{RST} output signal from the JTAG program/test equipment to the $\overline{RESET_IN}$ input on the UPSD34xx. The \overline{RST} signal is driven by the equipment with an Open Drain driver, allowing other sources (like a push button) to drive $\overline{RESET_IN}$ without conflict.

Note: The recommended pull-up resistors and decoupling capacitor are illustrated in *Figure 91*.

Figure 91. Recommended 4-pin JTAG connections

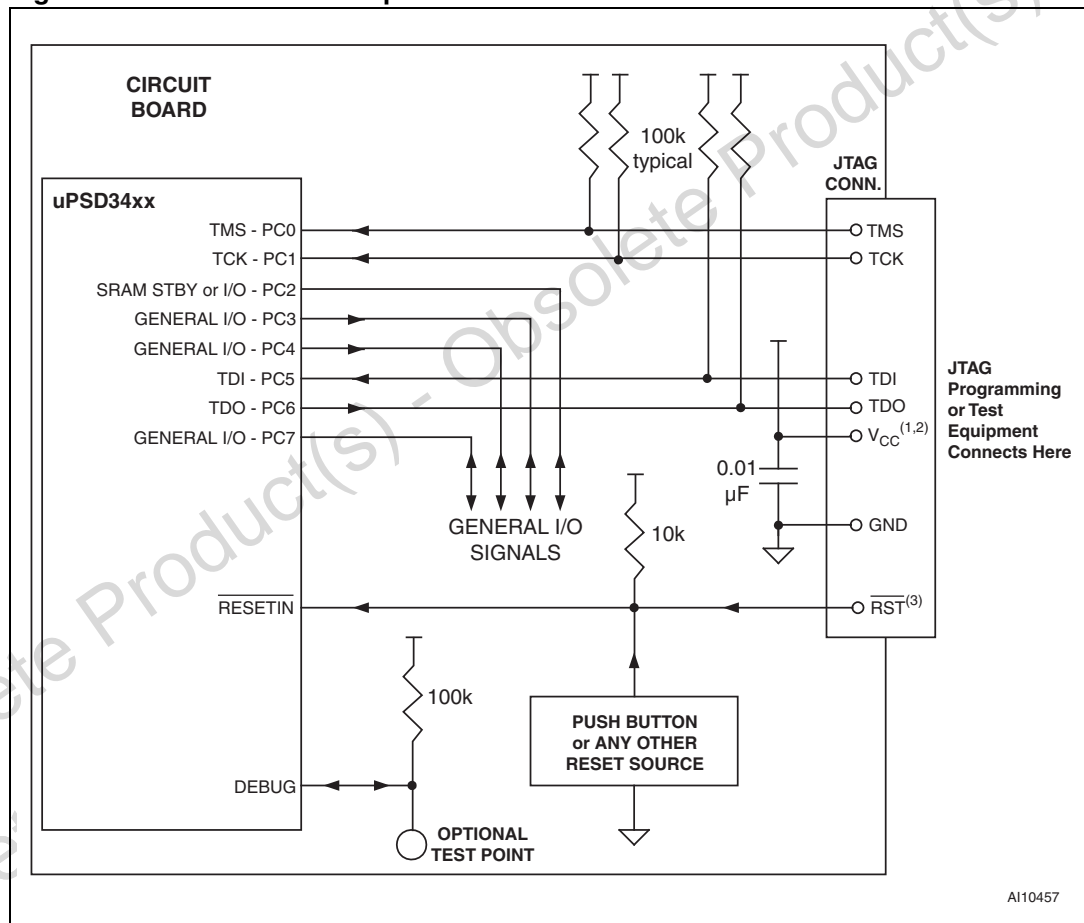

1. For 5 V UPSD34xx devices, pull-up resistors and V_{CC} pin on the JTAG connector should be connected to 5 V system V_{DD} .
2. For 3.3 V UPSD34xx devices, pull-up resistors and V_{CC} pin on the JTAG connector should be connected to 3.3 V system V_{CC} .
3. This signal is driven by an Open-Drain output in the JTAG equipment, allowing more than one source to activate $\overline{RESET_IN}$.

28.6.5 6-pin JTAG ISP (optional)

The optional signals TSTAT and $\overline{\text{TERR}}$ are programming status flags that can reduce programming time by as much as 30% compared to 4-pin JTAG because this status information does not have to be scanned out of the device serially. TSTAT and $\overline{\text{TERR}}$ must be used as a pair for 6-pin JTAG operation.

- TSTAT (pin PC3) indicates when programming of a single Flash location is complete. Logic 1 = Ready, Logic 0 = busy.
- $\overline{\text{TERR}}$ (pin PC4) indicates if there was a Flash programming error. Logic 1 = no error, Logic 0 = error.

The pin functions for PC3 and PC4 must be selected as “Dedicated JTAG - TSTAT” and “Dedicated JTAG - $\overline{\text{TERR}}$ ” in PSDsoft Express to enable 6-pin JTAG ISP.

No 8032 firmware is needed to use 6-pin ISP because all ISP functions are controlled from the external JTAG program/test equipment.

TSTAT and $\overline{\text{TERR}}$ are functional only when JTAG ISP operations are occurring, which means they are non-functional during JTAG debugging of the 8032 on the MCU module.

Programming times vary depending on the number of locations to be programmed and the JTAG programming equipment, but typical JTAG ISP programming times are 10 to 25 seconds using 6-pin JTAG. The signals TSTAT and $\overline{\text{TERR}}$ are not included in the IEEE 1149.1 specification.

Figure 92 on page 261 shows recommended connections on a circuit board to a JTAG program/test tool using 6-pin JTAG. It is required to connect the $\overline{\text{RST}}$ output signal from the JTAG program/test equipment to the $\overline{\text{RESET_IN}}$ input on the UPSD34xx. The $\overline{\text{RST}}$ signal is driven by the equipment with an Open Drain driver, allowing other sources (like a push button) to drive $\overline{\text{RESET_IN}}$ without conflict.

Note: The recommended pull-up resistors and decoupling capacitor are illustrated in *Figure 92*.

Figure 92. Recommended 6-pin JTAG connections

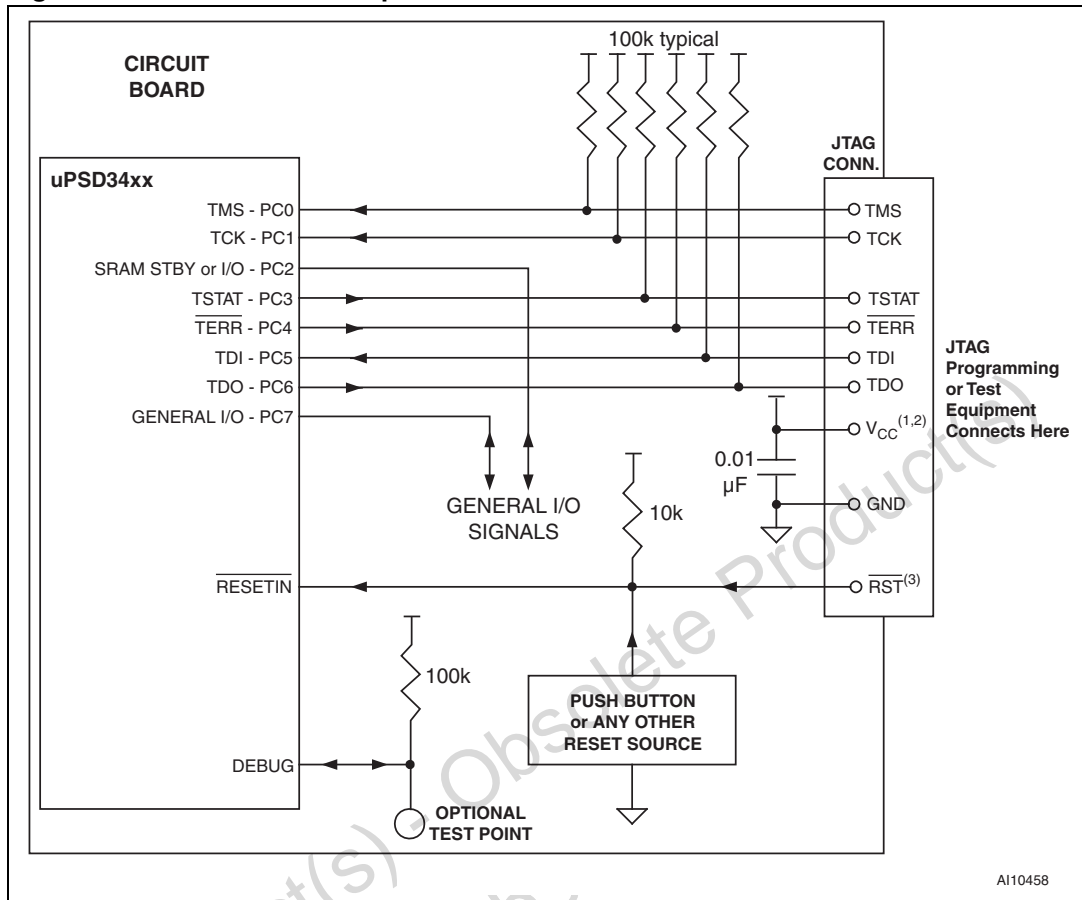

1. For 5 V UPSD34xx devices, pull-up resistors and V_{CC} pin on the JTAG connector should be connected to 5 V system V_{DD}.
2. For 3.3 V UPSD34xx devices, pull-up resistors and V_{CC} pin on the JTAG connector should be connected to 3.3 V system V_{CC}.
3. This signal is driven by an Open-Drain output in the JTAG equipment, allowing more than one source to activate RESET_IN.

28.6.6 Recommended JTAG connector

There is no industry standard JTAG connector. STMicroelectronics recommends a specific JTAG connector and pinout for uPSD3xxx so programming and debug equipment will easily connect to the circuit board. The user does not have to use this connector if there is a different connection scheme.

The recommended connector scheme can accept a standard 14-pin ribbon cable connector (2 rows of 7 pins on 0.1" centers, 0.025" square posts, standard keying) as shown in [Figure 93](#). See the STMicroelectronics "FlashLINK, FL-101 User Manual" for more information.

Figure 93. Recommended JTAG connector

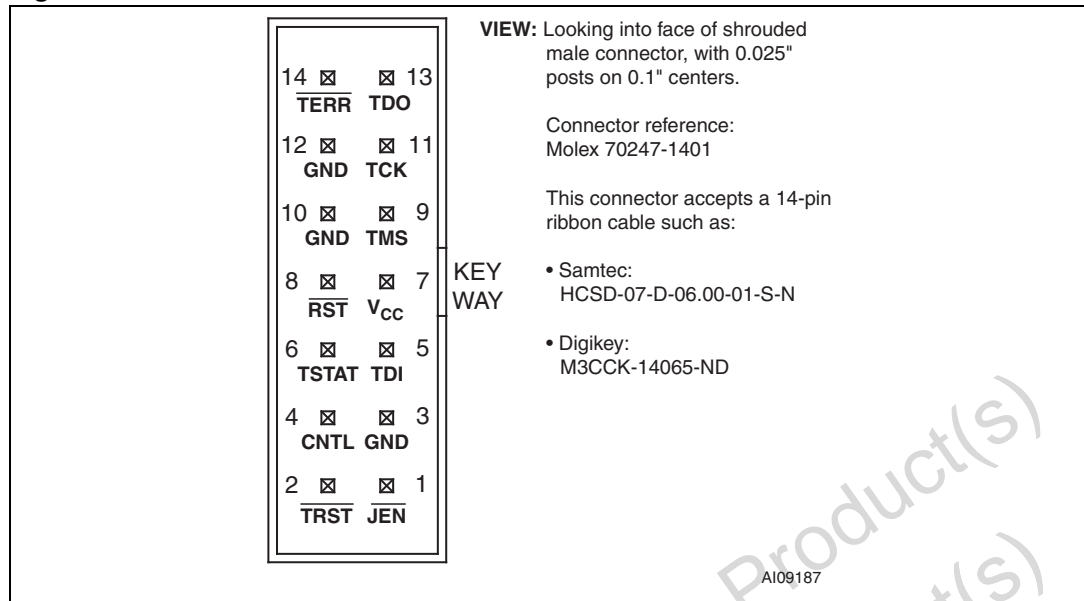

28.6.7 Chaining UPSD34xx devices

It is possible to chain a UPSD34xx device with other UPSD34xx devices on a circuit board, and also chain with IEEE 1149.1 compliant devices from other manufacturers. [Figure 94 on page 263](#) shows a chaining example. The TDO of one device connects to the TDI of the next device, and so on. Only one device is performing JTAG operations at any given time while the other two devices are in BYPASS mode. Configuration for JTAG chaining can be made in PSDsoft Express by choosing "More than one device" when prompted about chaining devices. Notice in [Figure 94 on page 263](#) that the UPSD34xx devices are chained externally, but also be aware that the two die within each UPSD34xx device are chained internally. This internal chaining of die is transparent to the user and is taken care of by PSDsoft Express and 3rd party JTAG tool software.

The example in [Figure 94 on page 263](#) also shows how to use 6-pin JTAG when chaining devices. The signals TSTAT and $\overline{\text{TERR}}$ are configured as open-drain type signals from PSDsoft Express. This facilitates a wired-OR connection of TSTAT signals from multiple UPSD34xx devices and also a wired-OR connection of $\overline{\text{TERR}}$ signals from those same multiple devices. PSDsoft Express puts TSTAT and $\overline{\text{TERR}}$ signals into open-drain mode by default, requiring external pull-up resistors. Click on 'Properties' in the JTAG-ISP window of PSDsoft Express to change to standard CMOS push-pull outputs if desired, but wired-OR logic is not possible in CMOS output mode.

Figure 94. Example of chaining UPSD34xx devices

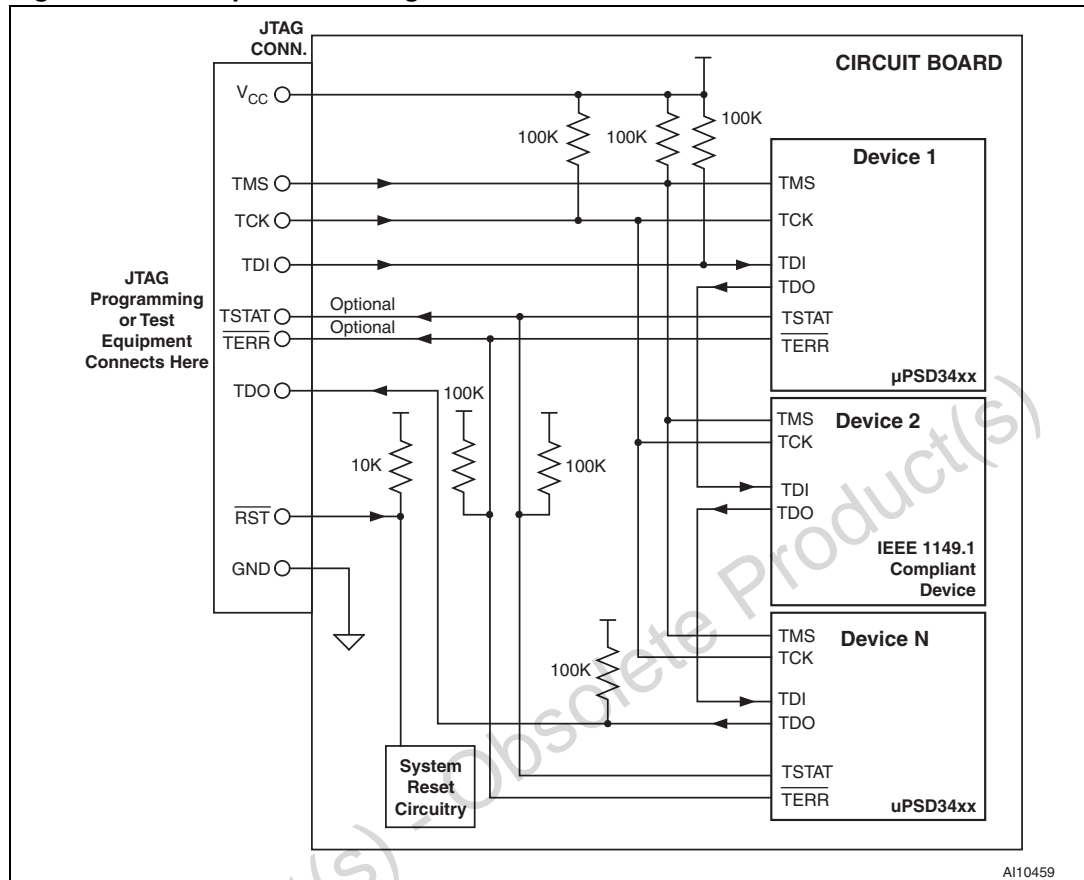

28.6.8 Debugging the 8032 MCU module

The 8032 on the MCU module may be debugged in-circuit using the same four basic JTAG signals as used for JTAG ISP (TDI, TDO, TCK, TMS). The signals TSTAT and TERR are not needed for debugging, and they will not create a problem if they exist on the circuit board while debugging. The same connector specified in [Figure 93 on page 262](#) can be used for ISP or for 8032 debugging. There are 3rd party suppliers of UPSD34xx JTAG debugging equipment (check www.st.com/psm). These are small pods which connect to a PC (or notebook computer) using a USB interface, and they are driven by an 8032 Integrated Development Environment (IDE) running on the PC.

Standard debugging features are provided through this JTAG interface such as single-step, breakpoints, trace, memory dump and fill, and others. There is also a dedicated Debug pin (shown in [Figure 90 on page 258](#)) which can be configured as an output to trigger external devices upon a programmable internal event (e.g., breakpoint match), or the pin can be configured as an input so an external device can initiate an internal debug event (e.g., break execution). The Debug pin function is configured by the 8032 IDE debug software tool. See [Section 12: Debug unit on page 60](#) for more details.

The Debug signal should always be pulled up externally with a weak pull-up (100 kΩ minimum) to V_{CC} even if nothing is connected to it, as shown in [Figure 91 on page 259](#) and [Figure 92 on page 261](#).

28.6.9 JTAG security setting

A programmable security bit in the PSD module protects its contents from unauthorized viewing and copying. The security bit is set by clicking on the “Additional PSD Settings” box in the main flow diagram of PSDsoft Express, then choosing to set the security bit. Once a file with this setting is programmed into a UPSD34xx using JTAG ISP, any further attempts to communicate with the UPSD34xx using JTAG will be limited. Once secured, the only JTAG operation allowed is a full-chip erase. No reading or modifying Flash memory or PLD logic is allowed. Debugging operations to the MCU module are also not allowed. The only way to defeat the security bit is to perform a JTAG ISP full-chip erase operation, after which the device is blank and may be used again. The 8032 on the MCU module will always have access to PSM Module memory contents through the 8-bit 8032 data bus connecting the two die, even while the security bit is set.

28.6.10 Initial delivery state

When delivered from STMicroelectronics, UPSD34xx devices are erased, meaning all Flash memory and PLD configuration bits are logic '1.' Firmware and PLD logic configuration must be programmed at least the first time using JTAG ISP. Subsequent programming of Flash memory may be performed using JTAG ISP, JTAG debugging, or the 8032 may run firmware to program Flash memory (IAP).

29 AC/DC parameters

These tables describe the AD and DC parameters of the UPSD34xx devices:

- DC electrical specification
- AC timing specification
- PLD timing
 - Combinatorial timing
 - Synchronous clock mode
 - Asynchronous clock mode
 - Input macrocell timing
- MCU module timing
 - READ timing
 - WRITE timing
 - Power-down and $\overline{\text{RESET}}$ timing

The following are issues concerning the parameters presented:

- In the DC specification the supply current is given for different modes of operation.
- The AC power component gives the PLD, Flash memory, and SRAM mA/MHz specification. [Figure 95](#) and [Figure 96](#) show the PLD mA/MHz as a function of the number of Product Terms (PT) used.
- In the PLD timing parameters, add the required delay when Turbo Bit is '0.'

Figure 95. PLD I_{CC} / frequency consumption (5 V range)

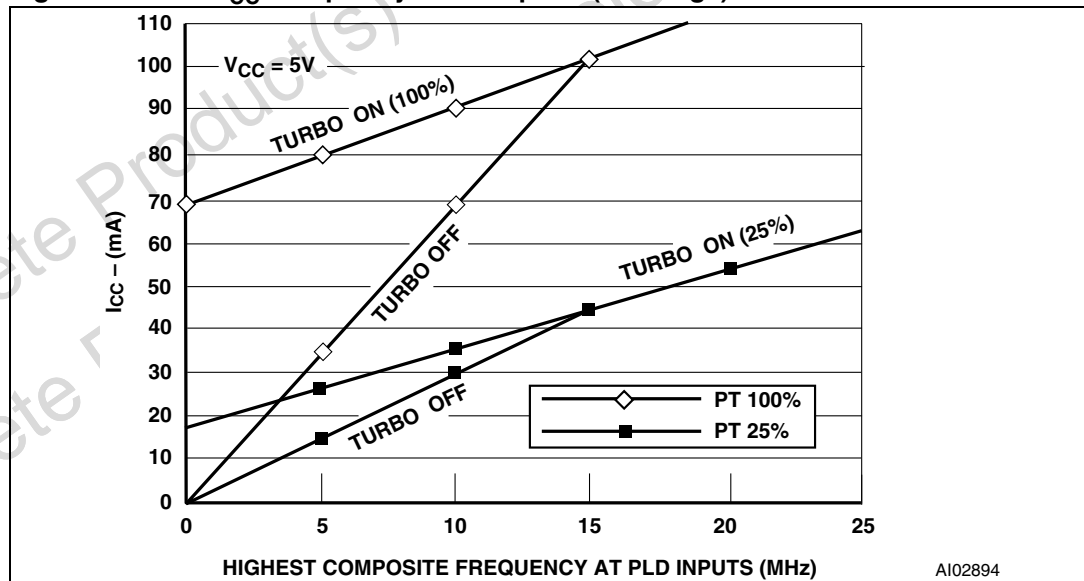

Figure 96. PLD I_{CC} / frequency consumption (3 V range)

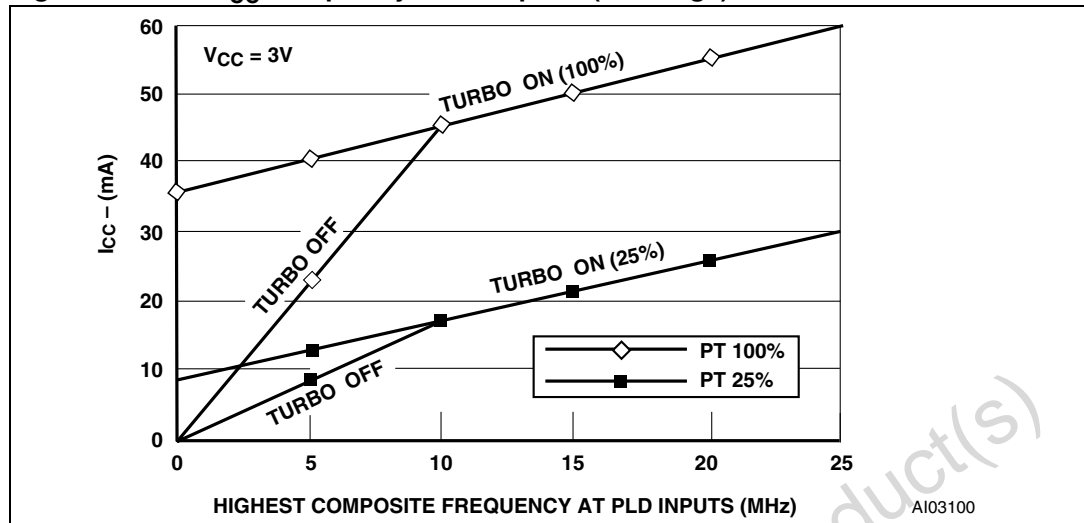

Table 204. PSD module example, typ. power calculation at V_{CC} = 5.0 V (turbo mode off)

Conditions		
MCU clock frequency	=	12 MHz
Highest composite PLD input frequency		
(Freq PLD)	=	8 MHz
MCU ALE frequency (Freq ALE)	=	2 MHz
% Flash memory access	=	80%
% SRAM access	=	15%
% I/O access	=	5% (no additional power above base)
Operational modes		
% Normal	=	40%
% Power-down mode	=	60%
Number of product terms used		
(from fitter report)	=	45 PT
% of total product terms	=	45/182 = 24.7%
Turbo mode	=	Off
Calculation (using typical values)		
I _{CC} total	=	I _{CC} (MCUactive) x %MCUactive + I _{CC} (PSDactive) x %PSDactive + I _{PD} (pwrdown) x %pwrdown

Table 204. PSD module example, typ. power calculation at $V_{CC} = 5.0\text{ V}$ (turbo mode off) (continued)

Conditions	
$I_{CC}(\text{MCUactive})$	= 20 mA
$I_{PD}(\text{pwrdown})$	= 250 μA
$I_{CC}(\text{PSDactive})$	= $I_{CC}(\text{ac}) + I_{CC}(\text{dc})$
	= %flash x 2.5 mA/MHz x Freq ALE
	+ %SRAM x 1.5 mA/MHz x Freq ALE
	+ % PLD x (from graph using Freq PLD)
	= $0.8 \times 2.5\text{ mA/MHz} \times 2\text{ MHz} + 0.15 \times 1.5\text{ mA/MHz} \times 2\text{ MHz} + 24\text{ mA}$
	= (4 + 0.45 + 24) mA
	= 28.45 mA
$I_{CC}\text{ total}$	= $20\text{ mA} \times 40\% + 28.45\text{ mA} \times 40\% + 250\ \mu\text{A} \times 60\%$
	= 8 mA + 11.38 mA + 150 μA
	= 19.53 mA
This is the operating power with no Flash memory Erase or Program cycles in progress. Calculation is based on all I/O pins being disconnected and $I_{OUT} = 0\text{ mA}$.	

30 Maximum rating

Stressing the device above the rating listed in the absolute maximum ratings table may cause permanent damage to the device. These are stress ratings only and operation of the device at these or any other conditions above those indicated in the operating sections of this specification is not implied. Exposure to absolute maximum rating conditions for extended periods may affect device reliability. Refer also to the STMicroelectronics SURE Program and other relevant quality documents.

Table 205. Absolute maximum ratings

Symbol	Parameter	Min.	Max.	Unit
T_{STG}	Storage temperature	-65	125	°C
T_{LEAD}	Lead temperature during soldering (20 seconds max.) ⁽¹⁾		235	°C
V_{IO}	Input and output voltage ($Q = V_{OH}$ or Hi-Z)	-0.5	6.5	V
V_{CC}, V_{DD}, AV_{CC}	Supply voltage	-0.5	6.5	V
V_{ESD}	Electrostatic discharge voltage (human body model) ⁽²⁾	-2000	2000	V

1. IPC/JEDEC J-STD-020A.

2. JEDEC Std JESD22-A114A ($C1=100\text{pF}$, $R1=1500\ \Omega$, $R2=500\ \Omega$).

31 DC and AC parameters

This section summarizes the operating and measurement conditions, and the DC and AC characteristics of the device. The parameters in the DC and AC characteristic tables that follow are derived from tests performed under the measurement conditions summarized in the relevant tables. Designers should check that the operating conditions in their circuit match the measurement conditions when relying on the quoted parameters.

Table 206. Operating conditions (5 V devices)

Symbol	Parameter	Min.	Max.	Unit
V_{DD}	Supply voltage	4.5	5.5	V
V_{CC}, AV_{CC}	Supply voltage	3.0	3.6	V
T_A	Ambient operating temperature (industrial)	-40	85	°C
	Ambient operating temperature (commercial)	0	70	°C

Table 207. Operating conditions (3.3 V devices)

Symbol	Parameter	Min.	Max.	Unit
V_{CC}, V_{DD}, AV_{CC}	Supply voltage	3.0	3.6	V
T_A	Ambient operating temperature (industrial)	-40	85	°C
	Ambient operating temperature (commercial)	0	70	°C

Table 208. AC signal letters for timing

Letter	Meaning
A	Address
C	Clock
D	Input data
I	Instruction
L	ALE
N	\overline{RESET} input or output
P	\overline{PSEN} signal
Q	Output data
R	RD signal
W	WR signal
M	Output Macrocell

Note: Example: t_{AVLX} = time from address valid to ALE invalid.

Table 209. AC signal behavior symbols for timing

Letter	Meaning
t	Time
L	Logic level low or ALE
H	Logic level high
V	Valid
X	No longer a valid logic level
Z	Float
PW	Pulse width

Note: Example: t_{AVLX} = time from address valid to ALE invalid.

Figure 97. Switching waveforms – key

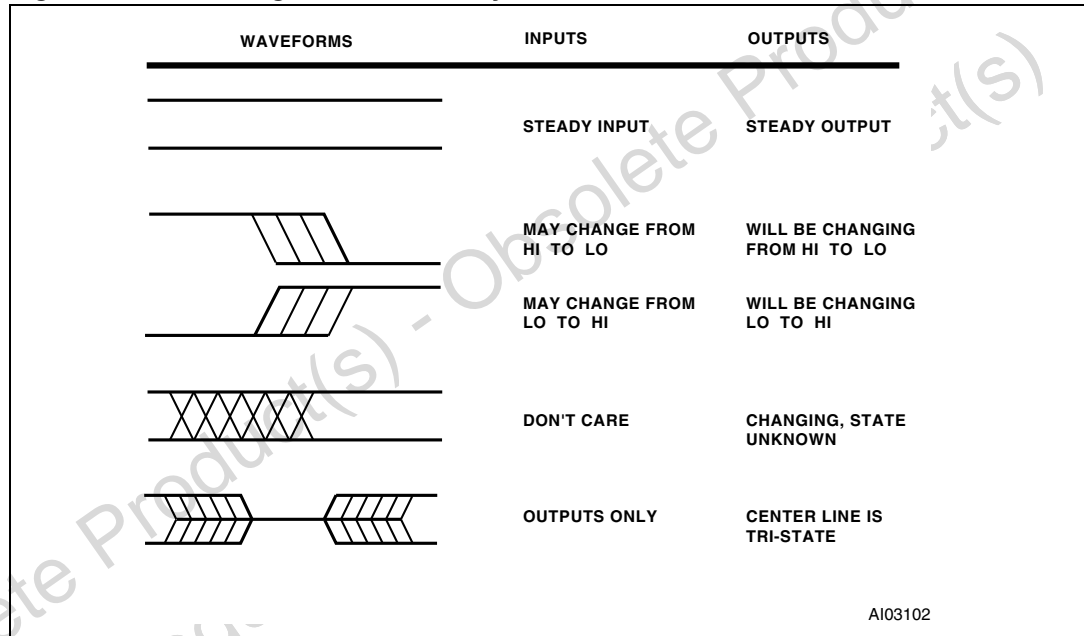

Table 210. Major parameters

Parameter	Test conditions/comments	5.0 V value	3.3 V value	Unit
Operating voltage	–	4.5 to 5.5 (PSD); 3.0 to 3.6 (MCU)	3.0 to 3.6 (PSD and MCU)	V
Operating temperature	–	–40 to 85	–40 to 85	°C
MCU frequency	8 MHz (min) for I ² C	3 Min, 40 Max	3 Min, 40 Max	MHz
Operating current, typical ⁽¹⁾ (20% of PLD used; 25°C operation. Bus control signals are blocked from the PLD in Non-turbo mode.)	40 MHz crystal, Turbo	79	63	mA
	40 MHz crystal, non-Turbo	71	58	mA
	8 MHz crystal, Turbo	32	24	mA
	8 MHz crystal, non-Turbo	17.7	14	mA
Idle current, typical (20% of PLD used; 25°C operation)	40 MHz crystal divided by 2048 internally. All interfaces are disabled.	19	18	mA
Standby current, typical	Power-down mode needs reset to exit.	140	120	µA
I/O sink/source current, ports A, B, C, and D	V _{OL} = 0.45 V (max); V _{OH} = 2.4 V (min)	I _{OL} = 8 (max); I _{OH} = –2 (min)	I _{OL} = 4 (max); I _{OH} = –1 (min)	mA
I/O sink/source current, port 4	V _{OL} = 0.6 V (max); V _{OH} = 2.4 V (min)	I _{OL} = 10 (max); I _{OH} = –10 (min)	I _{OL} = 10 (max); I _{OH} = –10 (min)	mA
PLD macrocells	For registered or combinatorial logic	16	16	–
PLD inputs	Inputs from pins, feedback, or MCU addresses	69	69	–
PLD outputs	Output to pins or internal feedback	18	18	–
PLD propagation delay, typical, Turbo mode	PLD input to output	15	22	ns

1. Operating current is measured while the UPSD34xx is executing a typical program at 40 MHz.

Table 211. MCU module DC characteristics

Symbol	Parameter	Test conditions	Min.	Typ.	Max.	Unit
V _{CC} , AV _{CC}	Supply voltage ⁽¹⁾		3.0		3.6	V
V _{IH}	High level input voltage (ports 0, 1, 3, 4, XTAL1, RESET) 5 V tolerant - max voltage 5.5 V	3.0 V < V _{CC} < 3.6 V	0.7V _{CC}		5.5 ⁽²⁾	V
V _{IL}	Low level input voltage (ports 0, 1, 3, 4, XTAL1, RESET)	3.0 V < V _{CC} < 3.6 V	V _{SS} – 0.5		0.3V _{CC}	V
V _{OL1}	Output low voltage (port 4)	I _{OL} = 10 mA			0.6	V
						V

Table 211. MCU module DC characteristics (continued)

Symbol	Parameter	Test conditions	Min.	Typ.	Max.	Unit
V_{OL2}	Output low voltage (other ports)	$I_{OL} = 5 \text{ mA}$			0.6	V
						V
V_{OH2}	Output high voltage (Port 0 push-pull)	$I_{OH} = -5 \text{ mA}$	2.4			V
						V
V_{OH3}	Output high voltage (other ports bidirectional mode)	$I_{OH} = -20 \text{ } \mu\text{A}$	2.4			V
V_{OP}	XTAL open bias voltage (XTAL1, XTAL2)	$I_{OL} = 3.2 \text{ mA}$	1.0		2.0	V
I_{RST}	RESET pin pull-up current (RESET)	$V_{IN} = V_{SS}$	-10		-55	μA
I_{FR}	XTAL feedback resistor current (XTAL1)	XTAL1 = V_{CC} ; XTAL2 = V_{SS}	-20		50	μA
I_{IHL1}	Input high leakage current (port 0)	$V_{SS} < V_{IN} < 5.5 \text{ V}$	-10		10	μA
I_{IHL2}	Input high leakage current (ports 1, 3, 4)	$V_{IH} = 2.3 \text{ V}$	-10		10	μA
I_{ILL}	Input low leakage current (ports 1, 3, 4)	$V_{IL} < 0.5 \text{ V}$	-10		10	μA
$I_{PD}^{(3)}$	Power-down mode	$V_{CC} = 3.6 \text{ V}$		65	95	μA
$I_{CC-CPU}^{(4)(5)(6)}$	Active - 12 MHz	$V_{CC} = 3.6 \text{ V}$		14	20	mA
	Idle - 12 MHz			10	12	mA
	Active - 24 MHz	$V_{CC} = 3.6 \text{ V}$		19	30	mA
	Idle - 24 MHz			13	17	mA
	Active - 40 MHz	$V_{CC} = 3.6 \text{ V}$		26	40	mA
	Idle - 40 MHz			17	22	mA

- Power supply (V_{CC} , AV_{CC}) is always 3.0 to 3.6 V for the MCU module. V_{DD} for the PSD module may be 3 V or 5 V.
- Port 1 is not 5 V tolerant; maximum $V_{IH} = V_{CC} + 0.5$.
- I_{PD} (Power-down Mode) is measured with: XTAL1 = V_{SS} ; XTAL2 = NC; RESET = V_{CC} ; Port 0 = V_{CC} ; all other pins are disconnected.
- I_{CC-CPU} (Active mode) is measured with: XTAL1 driven with t_{CLCH} , $t_{CHCL} = 5 \text{ ns}$, $V_{IL} = V_{SS} + 0.5 \text{ V}$, $V_{IH} = V_{CC} - 0.5 \text{ V}$, XTAL2 = NC; RESET = V_{SS} ; Port 0 = V_{CC} ; all other pins are disconnected. I_{CC} would be slightly higher if a crystal oscillator is used (approximately 1 mA).
- I_{CC-CPU} (Idle Mode) is measured with: XTAL1 driven with t_{CLCH} , $t_{CHCL} = 5 \text{ ns}$, $V_{IL} = V_{SS} + 0.5 \text{ V}$, $V_{IH} = V_{CC} - 0.5 \text{ V}$, XTAL2 = NC; RESET = V_{CC} ; Port 0 = V_{CC} ; all other pins are disconnected. I_{CC} would be slightly higher if a crystal oscillator is used (approximately 1 mA). All IP clocks are disabled and the MCU clock is set to $f_{OSC}/2048$.
- I/O current = 0 mA, all I/O pins are disconnected.

Table 212. PSD module DC characteristics (with 5 V V_{DD})

Symbol	Parameter		Test condition (in addition to those in Table 211 on page 271)	Min.	Typ.	Max.	Unit
V _{IH}	Input high voltage		4.5 V < V _{DD} < 5.5 V	2		V _{DD} +0.5	V
V _{IL}	Input low voltage		4.5 V < V _{DD} < 5.5 V	-0.5		0.8	V
V _{LKO}	V _{DD} (min) for Flash erase and program			2.5		4.2	V
V _{OL}	Output low voltage		I _{OL} = 20 μA, V _{DD} = 4.5 V		0.01	0.1	V
			I _{OL} = 8 mA, V _{DD} = 4.5 V		0.25	0.45	V
V _{OH}	Output high voltage		I _{OH} = -20 μA, V _{DD} = 4.5 V	4.4	4.49		V
			I _{OH} = -2 mA, V _{DD} = 4.5 V	2.4	3.9		V
I _{SB}	Standby supply current for power-down mode		$\overline{CS1} > V_{DD} - 0.3 V^{(1)(2)}$		120	250	μA
I _{LI}	Input leakage current		V _{SS} < V _{IN} < V _{DD}	-1	±0.1	1	μA
I _{LO}	Output leakage current		0.45 < V _{OUT} < V _{DD}	-10	±5	10	μA
I _{CC} (DC) ⁽³⁾	Operating supply current	PLD only	PLD_TURBO = Off, f = 0 MHz ⁽³⁾		0		μA/PT
			PLD_TURBO = On, f = 0 MHz		400	700	μA/PT
		Flash memory	During Flash memory WRITE/Erase Only		15	30	mA
			Read only, f = 0 MHz		0	0	mA
SRAM	f = 0 MHz		0	0	mA		
I _{CC} (AC) ⁽³⁾	PLD AC adder					(4)	
	Flash memory AC adder				1.5	2.5	mA/MHz
	SRAM AC adder				1.5	3.0	mA/MHz

1. Internal Power-down mode is active.
2. PLD is in non-Turbo mode, and none of the inputs are switching.
3. I_{OUT} = 0 mA.
4. Please see [Figure 95 on page 265](#) for the PLD current calculation.

Table 213. PSD module DC characteristics (with 3.3 V V_{DD})

Symb.	Parameter	Test condition (in addition to those in Table 211 on page 271)	Min.	Typ.	Max.	Unit	
V_{IH}	High level input voltage	$3.0\text{ V} < V_{DD} < 3.6\text{ V}$	$0.7V_{DD}$		$V_{DD} + 0.5$	V	
V_{IL}	Low level input voltage	$3.0\text{ V} < V_{DD} < 3.6\text{ V}$	-0.5		0.8	V	
V_{LKO}	V_{DD} (min) for Flash Erase and Program		1.5		2.2	V	
V_{OL}	Output low voltage	$I_{OL} = 20\ \mu\text{A}, V_{DD} = 3.0\text{ V}$		0.01	0.1	V	
		$I_{OL} = 4\text{ mA}, V_{DD} = 3.0\text{ V}$		0.15	0.45	V	
V_{OH}	Output high voltage	$I_{OH} = -20\ \mu\text{A}, V_{DD} = 3.0\text{ V}$	2.9	2.99		V	
		$I_{OH} = -1\text{ mA}, V_{DD} = 3.0\text{ V}$	2.7	2.8		V	
I_{SB}	Standby supply current for power-down mode	$\overline{CS1} > V_{DD} - 0.3\text{ V}^{(1)(2)}$		50	100	μA	
I_{LI}	Input leakage current	$V_{SS} < V_{IN} < V_{DD}$	-1	± 0.1	1	μA	
I_{LO}	Output leakage current	$0.45 < V_{IN} < V_{DD}$	-10	± 5	10	μA	
I_{CC} (DC) ⁽³⁾	Operating supply current	PLD Only	PLD_TURBO = Off, $f = 0\text{ MHz}^{(2)}$		0		$\mu\text{A}/\text{PT}$
			PLD_TURBO = On, $f = 0\text{ MHz}$		200	400	$\mu\text{A}/\text{PT}$
		Flash memory	During Flash memory WRITE/Erase Only		10	25	mA
			Read only, $f = 0\text{ MHz}$		0	0	mA
SRAM	$f = 0\text{ MHz}$		0	0	mA		
I_{CC} (AC) ⁽³⁾	PLD AC adder			(4)			
	Flash memory AC adder			1.0	1.5	mA/MHz	
	SRAM AC adder			0.8	1.5	mA/MHz	

1. Internal PD is active.
2. PLD is in non-Turbo mode, and none of the inputs are switching.
3. $I_{OUT} = 0\text{ mA}$.
4. Please see [Figure 96 on page 266](#) for the PLD current calculation.

Figure 98. External READ cycle (80-pin device only)

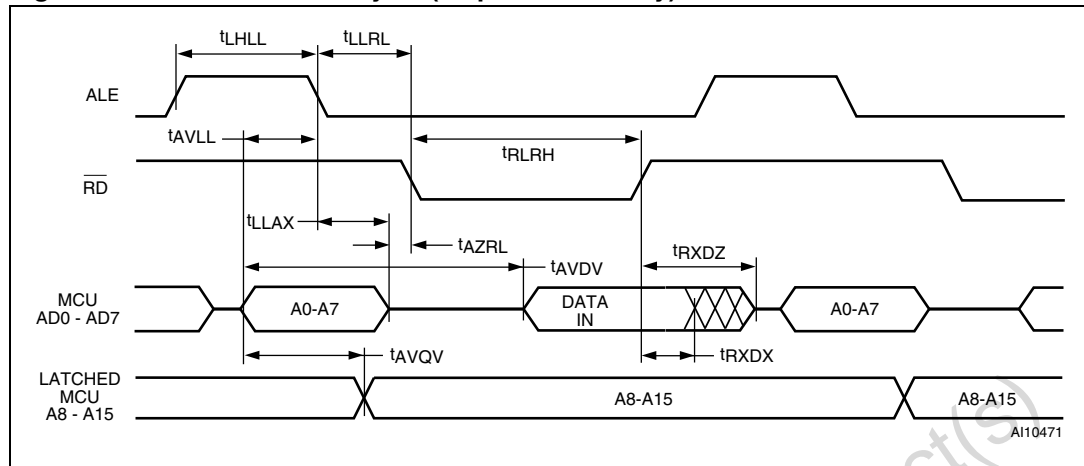

Table 214. External READ cycle AC characteristics (3 V or 5 V device)

Symbol	Parameter	40 MHz oscillator ⁽¹⁾		Variable oscillator 1/t _{CLCL} = 3 to 40 MHz		Unit
		Min	Max	Min	Max	
t _{LHLL}	ALE pulse width	17		t _{CLCL} - 8		ns
t _{AVLL}	Address setup to ALE	13		t _{CLCL} - 12		ns
t _{LLAX}	Address hold after ALE	7.5		0.5t _{CLCL} - 5		ns
t _{LLRL}	ALE to \overline{RD}	7.5		0.5t _{CLCL} - 5		ns
t _{RLRH}	\overline{RD} pulse width ⁽²⁾	40		nt _{CLCL} - 10		ns
t _{RXIX}	Input data hold after \overline{RD}	2		2		ns
t _{RHIZ}	Input data float after \overline{RD}		10.5		0.5t _{CLCL} - 2	ns
t _{AVDX}	Address to valid data in ⁽²⁾		70		mt _{CLCL} - 5	ns
t _{AZRL}	Address float to \overline{RD}	-2		-2		ns
t _{AVQV}	Address valid to latched address out on Ports A and B		35.5 (3 V)		1.5t _{CLCL} - 2	ns
			28 (5 V)		t _{CLCL} - 9.5	ns

- BUSCON register is configured for 4 PFQCLK.
- Refer to Table 215 for “n” and “m” values.

Table 215. n, m, and x, y values

# of PFQCLK in BUSCON register	READ cycle		WRITE cycle	
	n	m	x	y
4	2	3	2	1
5	3	4	3	2
6	4	5	4	3
7	5	6	5	4

Figure 99. External WRITE cycle (80-pin device only)

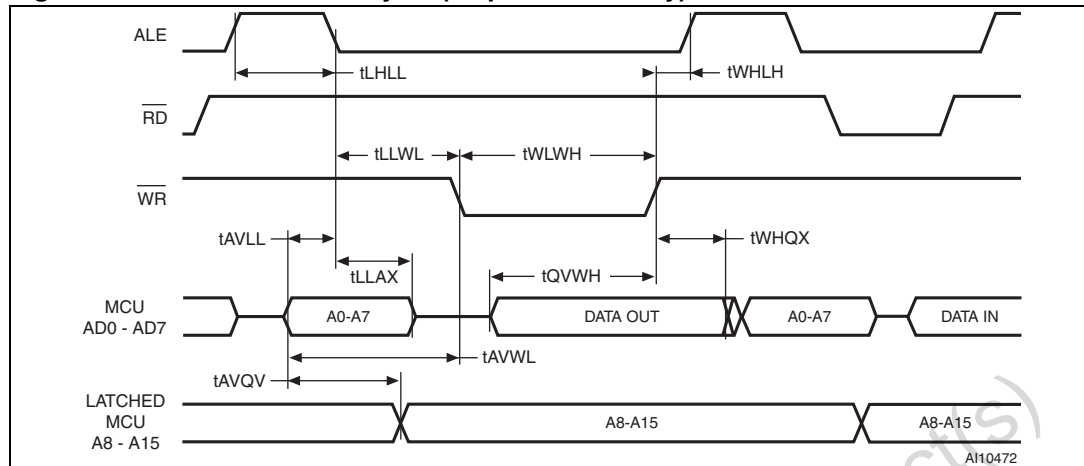

Table 216. External WRITE cycle AC characteristics (3 V or 5 V device)

Symbol	Parameter	40 MHz oscillator ⁽¹⁾		Variable oscillator 1/t _{CLCL} = 3 to 40 MHz		Unit
		Min	Max	Min	Max	
t _{LHLL}	ALE pulse width	17		t _{CLCL} - 8		ns
t _{AVLL}	Address setup to ALE	13		t _{CLCL} - 12		ns
t _{LLAX}	Address hold after ALE	7.5		0.5t _{CLCL} - 5		ns
t _{WLWH}	WR pulse width ⁽²⁾	40		x t _{CLCL} - 10		ns
t _{LLWL}	ALE to \overline{WR}	7.5		0.5t _{CLCL} - 5		ns
t _{AVWL}	Address (A0-A7) valid to \overline{WR} ⁽³⁾	32.5		1.5t _{CLCL} - 5		ns
t _{WHLH}	\overline{WR} High to ALE High	9.5	9.5	0.5t _{CLCL} - 3	0.5t _{CLCL} + 2	ns
t _{QVWH}	Data setup before \overline{WR} ^(v)	20		y t _{CLCL} - 5		ns
t _{WHQX}	Data hold after \overline{WR}	9.5	14.5	0.5t _{CLCL} - 3	0.5t _{CLCL} + 2	ns
t _{AVQV}	Address valid to Latched Address out on Ports A and B		35.5 (3 V)		1.5t _{CLCL} - 2	ns
			28 (5 V)		t _{CLCL} - 9.5	ns

1. BUSCON register is configured for 4 PFQCLK.
2. Refer to [Table 217 on page 277](#), for “n” and “m” values.
3. Latched address out on Ports A and B to \overline{WR} is 2 ns, minimum.

Table 217. External clock drive

Symbol	Parameter	Variable oscillator 1/t _{CLCL} = 3 to 40 MHz		Unit
		Min	Max	
t _{CLCL}	Oscillator period	25	333	ns
t _{CHCX}	High time	10	t _{CLCL} - t _{CLCX}	ns
t _{CLCX}	Low time	10	t _{CLCL} - t _{CLCX}	ns
t _{CLCH}	Rise time		10	ns
t _{CHCL}	Fall time		10	ns

Table 218. A/D analog specification

Symbol	Parameter	Test conditions ⁽¹⁾	Min.	Typ.	Max.	Unit
I _{DD}	Normal	Input = AV _{REF}		4.0		mA
	Power-down				40	μA
AV _{IN}	Analog input voltage		GND		AV _{REF}	V
AV _{REF} ⁽²⁾ (3)	Analog reference voltage				3.6	V
Accuracy	Resolution				10	bits
INL	Integral nonlinearity	Input = 0 to AV _{REF} (V) f _{OSC} ≤ 32MHz			±2	LSB
DNL	Differential nonlinearity	Input = 0 to AV _{REF} (V) f _{OSC} ≤ 32MHz			±2	LSB
SNR	Signal to noise ratio	f _{SAMPLE} = 500ksps	50	54		dB
SNDR	Signal to noise distortion ratio		48	52		dB
ACLK	ADC clock		2	8	16	MHz
t _C	Conversion time	8MHz	1	4	8	μs
t _{CAL}	Power-up time	Calibration Time		16		ms
f _{IN}	Analog input frequency				60	kHz
THD	Total harmonic distortion		50	54		dB

1. f_{IN} 2kHz, ACLK = 8MHz, AV_{REF} = AV_{CC} = 3.3 V.
2. AV_{REF} = AV_{CC} in 52-pin package.
3. If the A/D converter is not used, connect AV_{CC}/AV_{REF} to V_{CC}.

Table 219. USB transceiver specification

Symbol	Parameter	Test conditions ⁽¹⁾	Min.	Typ.	Max.	Unit
UV _{OH}	High output voltage	V _{DD} = 3.3 V; I _{OUT} = 2.2mA	3		-	V
UV _{OL}	Low output voltage	V _{DD} = 3.3 V; I _{OUT} = 2.2mA	-		0.25	V
UV _{IH}	High input voltage	V _{DD} = 3.6 V	2		-	V

Table 219. USB transceiver specification

Symbol	Parameter	Test conditions ⁽¹⁾	Min.	Typ.	Max.	Unit
UV_{IL}	Low input voltage	$V_{DD} = 3.6V$			0.8	V
R_{DH}	Output impedance (high state)	(2)	28		43	Ω
R_{DL}	Output impedance (low state)	(2)	28		43	Ω
I_L	Input leakage current	$V_{DD} = 3.6 V$		± 0.1	± 5	μA
I_{OZ}	3-state output OFF state current	$V_I = V_{IH}$ or V_{IL}			± 10	μA
V_{CR}	Crossover point		1.3		2	V
t_{RISE}	Rise time		4		20	ns
t_{FALL}	Fall time		4		20	ns

1. Temperature range = $-45^{\circ}C$ to $85^{\circ}C$.
2. This value includes an external resistor of $24\Omega \pm 1\%$.

Figure 100. Input to output disable / enable

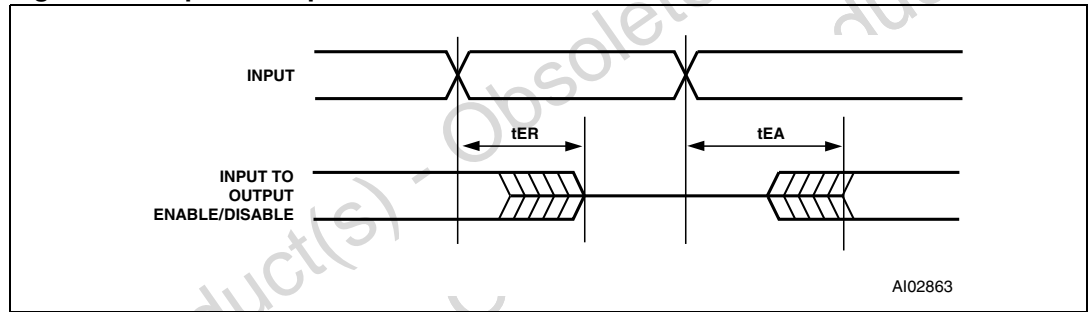

Table 220. CPLD combinatorial timing (5 V PSD module)

Symbol	Parameter	Conditions	Min	Max	PT Alloc	Turbo off	Slew rate ⁽¹⁾	Unit
t _{PD} ⁽²⁾	CPLD input pin/feedback to CPLD combinatorial output			20	+ 2	+ 10	- 2	ns
t _{EA}	CPLD input to CPLD Output Enable			21		+ 10	- 2	ns
t _{ER}	CPLD input to CPLD Output Disable			21		+ 10	- 2	ns
t _{ARP}	CPLD register clear or preset delay			21		+ 10	- 2	ns
t _{ARPW}	CPLD register clear or preset pulse width		10			+ 10		ns
t _{ARD}	CPLD array delay	Any macrocell		11	+ 2			ns

1. Fast Slew Rate output available on PA3-PA0, PB3-PB0, and PD2-PD1. Decrement times by given amount.
2. t_{PD} for MCU address and control signals refers to delay from pins on Port 0, Port 2, \overline{RD} , \overline{WR} , \overline{PSEN} and \overline{ALE} to CPLD combinatorial output (80-pin package only).

Table 221. CPLD combinatorial timing (3 V PSD module)

Symbol	Parameter	Conditions	Min	Max	PT Alloc	Turbo off	Slew rate ⁽¹⁾	Unit
t _{PD} ⁽²⁾	CPLD input pin/feedback to CPLD combinatorial output			35	+ 4	+ 15	- 6	ns
t _{EA}	CPLD input to CPLD Output Enable			38		+ 15	- 6	ns
t _{ER}	CPLD input to CPLD Output Disable			38		+ 15	- 6	ns
t _{ARP}	CPLD register clear or preset delay			35		+ 15	- 6	ns
t _{ARPW}	CPLD register clear or preset pulse width		18			+ 15		ns
t _{ARD}	CPLD array delay	Any macrocell		20	+ 4			ns

1. Fast Slew Rate output available on PA3-PA0, PB3-PB0, and PD2-PD1. Decrement times by given amount.
2. t_{PD} for MCU address and control signals refers to delay from pins on Port 0, Port 2, \overline{RD} , \overline{WR} , \overline{PSEN} and \overline{ALE} to CPLD combinatorial output (80-pin package only).

Figure 101. Synchronous Clock mode timing – PLD

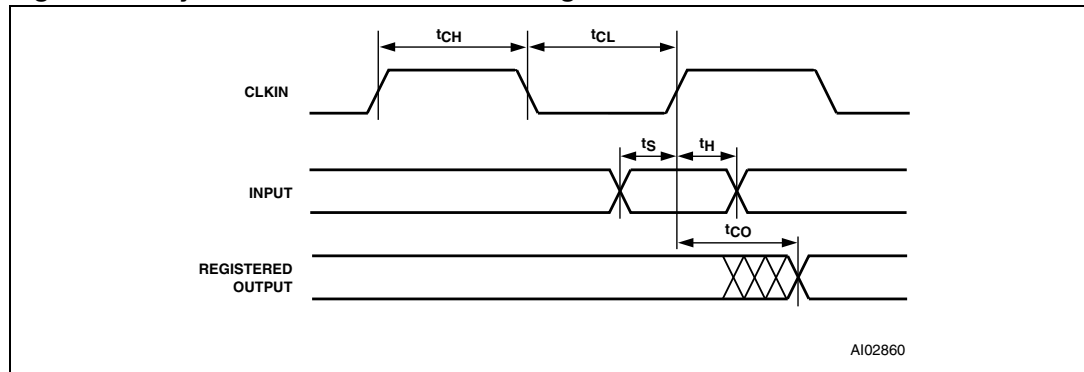

Table 222. CPLD macrocell synchronous clock mode timing (5 V PSD module)

Symbol	Parameter	Conditions	Min	Max	PT Alloc	Turbo Off	Slew rate ⁽¹⁾	Unit
f _{MAX}	Maximum frequency external feedback	1/(t _S +t _{CO})		40.0				MHz
	Maximum frequency internal feedback (f _{CNT})	1/(t _S +t _{CO} -10)		66.6				MHz
	Maximum frequency pipelined data	1/(t _{CH} +t _{CL})		83.3				MHz
t _S	Input setup time		12		+ 2	+ 10		ns
t _H	Input hold time		0					ns
t _{CH}	Clock high time	Clock input	6					ns
t _{CL}	Clock low time	Clock input	6					ns
t _{CO}	Clock to output delay	Clock input		13			- 2	ns
t _{ARD}	CPLD array delay	Any macrocell		11	+ 2			ns
t _{MIN}	Minimum clock period ⁽²⁾	t _{CH} +t _{CL}	12					ns

1. Fast slew rate output available on PA3-PA0, PB3-PB0, and PD2-PD1. Decrement times by given amount.

2. CLKIN (PD1) t_{CLCL} = t_{CH} + t_{CL}.

Table 223. CPLD macrocell synchronous clock mode timing (3 V PSD module)

Symbol	Parameter	Conditions	Min	Max	PT Alloc	Turbo off	Slew rate ⁽¹⁾	Unit
f _{MAX}	Maximum frequency external feedback	1/(t _S +t _{CO})		23.2				MHz
	Maximum frequency internal feedback (f _{CNT})	1/(t _S +t _{CO} -10)		30.3				MHz
	Maximum frequency pipelined data	1/(t _{CH} +t _{CL})		40.0				MHz
t _S	Input setup time		20		+ 4	+ 15		ns
t _H	Input hold time		0					ns
t _{CH}	Clock high time	Clock input	15					ns
t _{CL}	Clock low time	Clock input	10					ns
t _{CO}	Clock to output delay	Clock input		23			- 6	ns
t _{ARD}	CPLD array delay	Any macrocell		20	+ 4			ns
t _{MIN}	Minimum clock period ⁽²⁾	t _{CH} +t _{CL}	25					ns

1. Fast slew rate output available on PA3-PA0, PB3-PB0, and PD2-PD1. Decrement times by given amount..
2. CLKIN (PD1) t_{CLCL} = t_{CH} + t_{CL}.

Figure 102. Asynchronous RESET / Preset

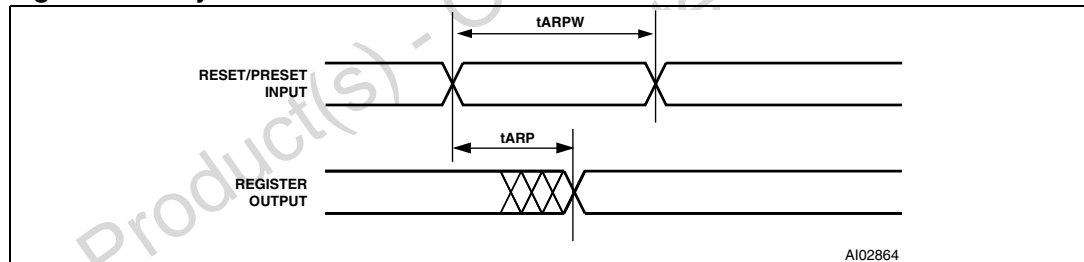

Figure 103. Asynchronous clock mode timing (product term clock)

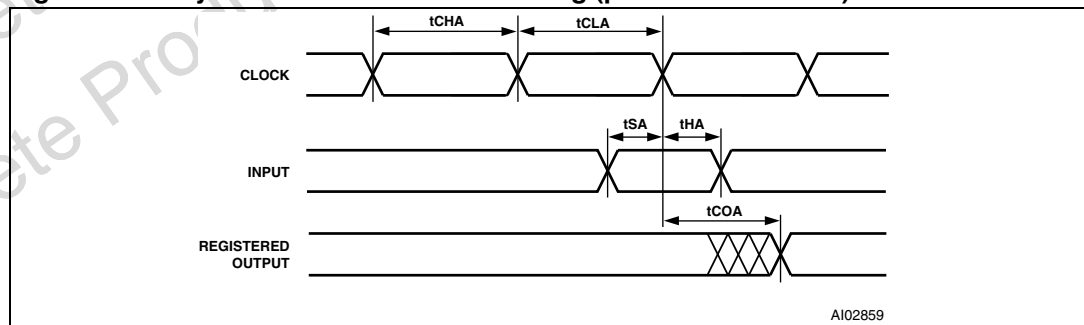

Table 224. CPLD macrocell asynchronous clock mode timing (5 V PSD module)

Symbol	Parameter	Conditions	Min	Max	PT Alloc	Turbo off	Slew rate	Unit
f _{MAXA}	Maximum frequency external feedback	1/(t _{SA} +t _{COA})		38.4				MHz
	Maximum frequency internal feedback (f _{CNTA})	1/(t _{SA} +t _{COA} -10)		62.5				MHz
	Maximum frequency pipelined data	1/(t _{CHA} +t _{CLA})		71.4				MHz
t _{SA}	Input setup time		7		+ 2	+ 10		ns
t _{HA}	Input hold time		8					ns
t _{CHA}	Clock input high time		9			+ 10		ns
t _{CLA}	Clock input low time		9			+ 10		ns
t _{COA}	Clock to output delay			21		+ 10	- 2	ns
t _{ARDA}	CPLD array delay	Any macrocell		11	+ 2			ns
t _{MINA}	Minimum clock period	1/f _{CNTA}	16					ns

Table 225. CPLD macrocell asynchronous clock mode timing (3 V PSD module)

Symbol	Parameter	Conditions	Min	Max	PT Alloc	Turbo off	Slew rate	Unit
f _{MAXA}	Maximum frequency external feedback	1/(t _{SA} +t _{COA})		21.7				MHz
	Maximum frequency internal feedback (f _{CNTA})	1/(t _{SA} +t _{COA} -10)		27.8				MHz
	Maximum frequency pipelined data	1/(t _{CHA} +t _{CLA})		33.3				MHz
t _{SA}	Input setup time		10		+ 4	+ 15		ns
t _{HA}	Input hold time		12					ns
t _{CHA}	Clock high time		17			+ 15		ns
t _{CLA}	Clock low time		13			+ 15		ns
t _{COA}	Clock to output delay			31		+ 15	- 6	ns
t _{ARD}	CPLD array delay	Any macrocell		20	+ 4			ns
t _{MINA}	Minimum clock period	1/f _{CNTA}	36					ns

Figure 104. Input macrocell timing (product term clock)

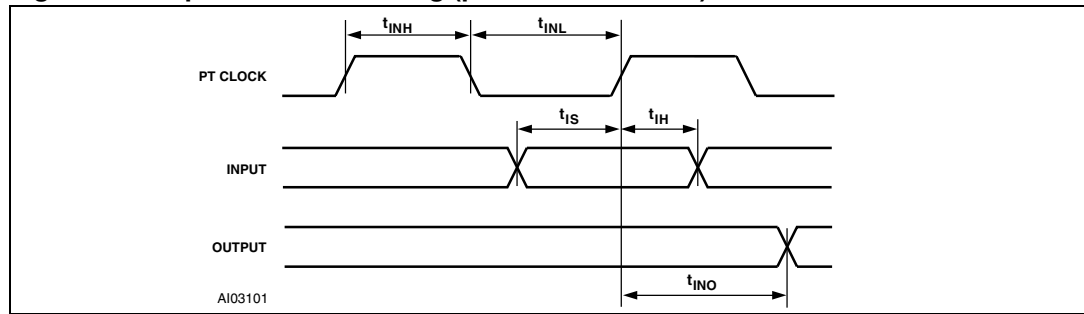

Table 226. Input macrocell timing (5 V PSD module)

Symbol	Parameter	Conditions	Min	Max	PT Alloc	Turbo off	Unit
t_{IS}	Input setup time	(1)	0				ns
t_{IH}	Input hold time		15			+ 10	ns
t_{INH}	NIB input high time		9				ns
t_{INL}	NIB input low time		9				ns
t_{INO}	NIB input to combinatorial delay				34	+ 2	+ 10

1. Inputs from Port A, B, and C relative to register/ latch clock from the PLD. ALE/AS latch timings refer to t_{AVLX} and t_{LXAX} .

Table 227. Input macrocell timing (3 V PSD module)

Symbol	Parameter	Conditions	Min	Max	PT Alloc	Turbo off	Unit
t_{IS}	Input setup time	(1)	0				ns
t_{IH}	Input hold time	(Note 1)	25			+ 15	ns
t_{INH}	NIB input high time	(Note 1)	12				ns
t_{INL}	NIB input low time	(Note 1)	12				ns
t_{INO}	NIB input to combinatorial delay	(Note 1)		43	+ 4	+ 15	ns

1. Inputs from Port A, B, and C relative to register/latch clock from the PLD. ALE latch timings refer to t_{AVLX} and t_{LXAX} .

Table 228. Program, WRITE and erase times (5 V, 3 V PSD modules)

Symbol	Parameter	Min.	Typ.	Max.	Unit
	Flash program		8.5		s
	Flash bulk erase ⁽¹⁾ (pre-programmed)		3 ⁽²⁾	10	s
	Flash bulk erase (not pre-programmed)		5		s
t_{WHQV3}	Sector erase (pre-programmed)		1	10	s
t_{WHQV2}	Sector erase (not pre-programmed)		2.2		s
t_{WHQV1}	byte program		14	150	μ s
	Program / erase cycles (per sector)	100 000			cycles

Table 228. Program, WRITE and erase times (5 V, 3 V PSD modules) (continued)

Symbol	Parameter	Min.	Typ.	Max.	Unit
	PLD program / erase cycles	1 000			cycles
t_{WHWLO}	Sector erase timeout		100		μ s
t_{Q7VQV}	DQ7 valid to output (DQ7-DQ0) valid (data polling) ⁽³⁾			30	ns

1. Programmed to all zero before erase.
2. Typical after 100 000 Write/Erase cycles is 5 seconds.
3. The polling status, DQ7, is valid t_{Q7VQV} time units before the data byte, DQ0-DQ7, is valid for reading.

Figure 105. Peripheral I/O READ timing

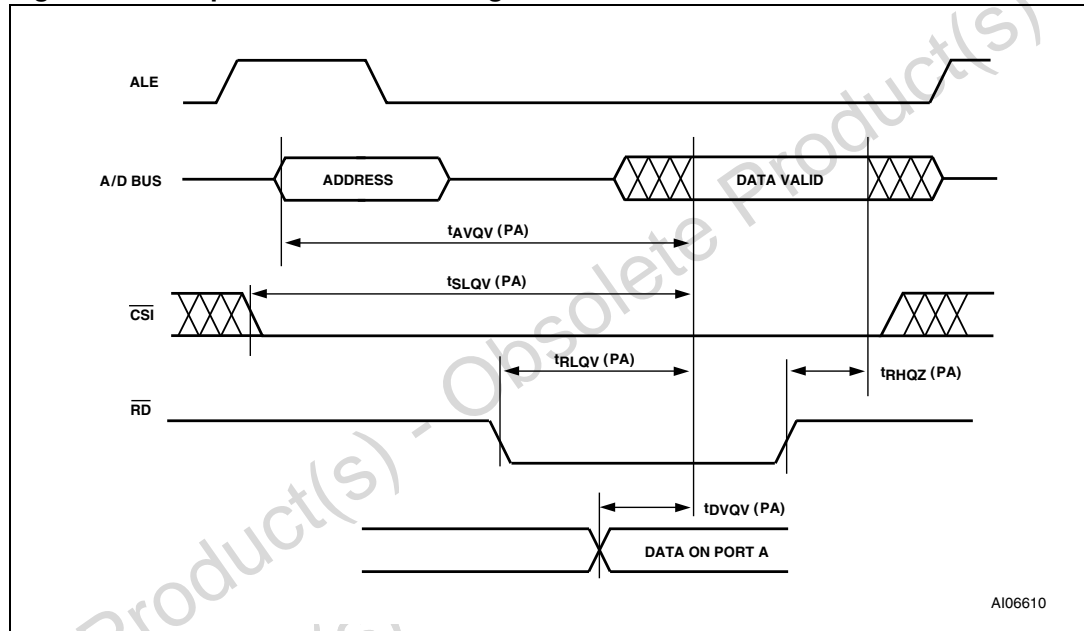

Table 229. Port A peripheral data mode READ timing (5 V PSD module)

Symbol	Parameter	Conditions	Min	Max	Turbo off	Unit
$t_{AVQV-PA}$	Address valid to data valid	(1)		37	+ 10	ns
$t_{SLQV-PA}$	\overline{CSI} valid to data valid			27	+ 10	ns
$t_{RLQV-PA}$	\overline{RD} to data valid	(2)		32		ns
$t_{DVQV-PA}$	Data in to data out valid			22		ns
$t_{RHQZ-PA}$	\overline{RD} to data High-Z			23		ns

1. Any input used to select Port A peripheral mode.
2. Data is already stable on Port A.

Table 230. Port A peripheral data mode READ timing (3 V PSD module)

Symbol	Parameter	Conditions	Min	Max	Turbo off	Unit
$t_{AVQV-PA}$	Address valid to data valid	(1)		50	+ 15	ns
$t_{SLQV-PA}$	\overline{CS} valid to data valid			37	+ 15	ns
$t_{RLQV-PA}$	\overline{RD} to data valid	(2)		45		ns
$t_{DVQV-PA}$	Data in to data out valid			38		ns
$t_{RHQZ-PA}$	\overline{RD} to data High-Z			36		ns

- Any input used to select Port A data peripheral mode.
- Data is already stable on Port A.

Figure 106. Peripheral I/O WRITE timing

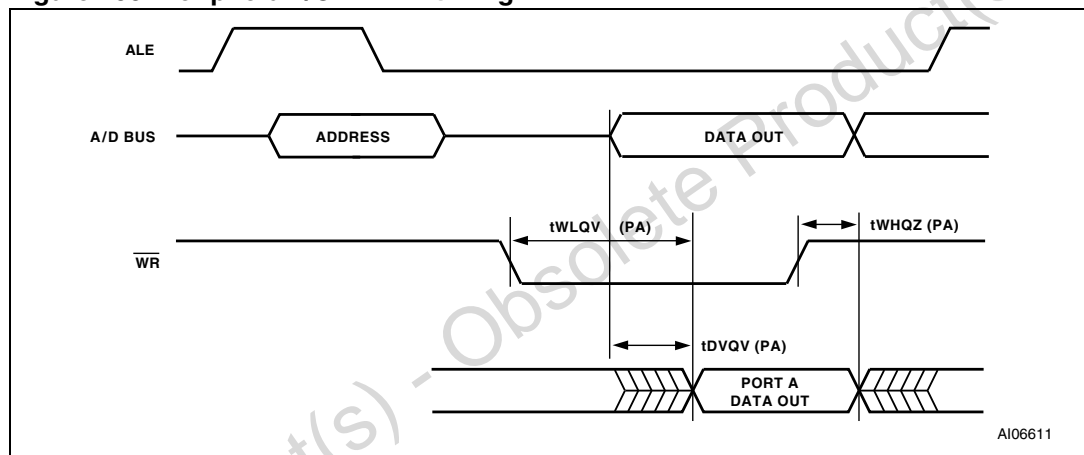

Table 231. Port A peripheral data mode WRITE timing (5 V PSD module)

Symbol	Parameter	Conditions	Min	Max	Unit
$t_{WLQV-PA}$	\overline{WR} to data propagation delay			25	ns
$t_{DVQV-PA}$	Data to port A data propagation delay	(1)		22	ns
$t_{WHQZ-PA}$	\overline{WR} Invalid to port a tri-state			20	ns

- Data stable on Port 0 pins to data on Port A.

Table 232. Port A peripheral data mode WRITE timing (3 V PSD module)

Symbol	Parameter	Conditions	Min	Max	Unit
$t_{WLQV-PA}$	\overline{WR} to data propagation delay			42	ns
$t_{DVQV-PA}$	Data to port A data propagation delay	(1)		38	ns
$t_{WHQZ-PA}$	\overline{WR} Invalid to port a tri-state			33	ns

- Data stable on Port 0 pins to data on Port A.

Table 233. Supervisor reset and LVD

Symbol	Parameter	Conditions	Min	Typ	Max	Unit
$t_{RST_LO_IN}$	Reset input duration		1 ⁽¹⁾			μs
t_{RST_ACTV}	Generated reset duration	$f_{OSC} = 40 \text{ MHz}$	10 ⁽²⁾			ms
t_{RST_FIL}	Reset input spike filter			1		μs
V_{RST_HYS}	Reset input hysteresis	$V_{CC} = 3.3 \text{ V}$		0.1		V
V_{RST_THRESH}	LVD trip threshold	$V_{CC} = 3.3 \text{ V}$	2.4	2.6	2.8	V

- 25 μs minimum to abort a Flash memory program or erase cycle in progress.
- As f_{OSC} decreases, t_{RST_ACTV} increases. Example: $t_{RST_ACTV} = 50 \text{ ms}$ when $f_{OSC} = 8 \text{ MHz}$.

Figure 107. ISC timing

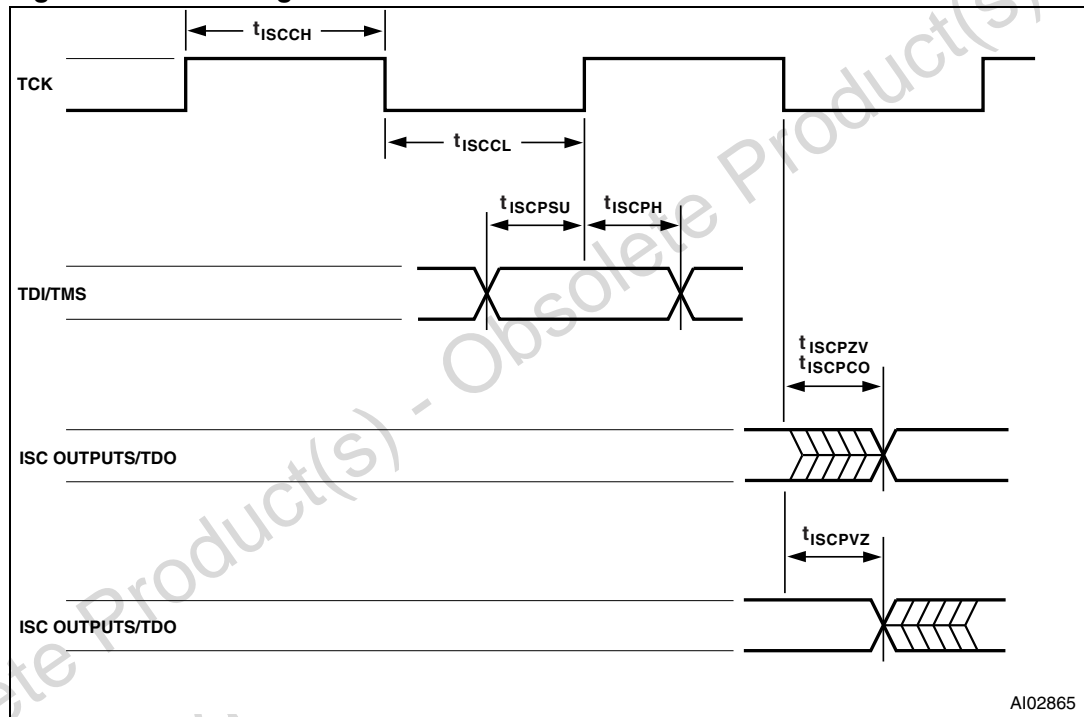

Table 234. ISC timing (5 V PSD module)

Symbol	Parameter	Conditions	Min	Max	Unit
t_{ISCCF}	Clock (TCK, PC1) frequency (except for PLD)	(1)		20	MHz
t_{ISCCH}	Clock (TCK, PC1) high time (except for PLD)		23		ns
t_{ISCCL}	Clock (TCK, PC1) low time (except for PLD)		23		ns
t_{ISCCFP}	Clock (TCK, PC1) frequency (PLD only)	(2)		4	MHz
t_{ISCCHP}	Clock (TCK, PC1) high time (PLD only)		90		ns
t_{ISCCLP}	Clock (TCK, PC1) low time (PLD only)		90		ns
t_{ISCPSU}	ISC port setup time		7		ns
t_{ISCPH}	ISC port hold up time		5		ns

Table 234. ISC timing (5 V PSD module) (continued)

Symbol	Parameter	Conditions	Min	Max	Unit
t_{ISCPCO}	ISC port clock to output			21	ns
t_{ISCPZV}	ISC port high-impedance to valid output			21	ns
t_{ISCPVZ}	ISC port valid output to high-impedance			21	ns

1. For non-PLD programming, erase or in ISC bypass mode.
2. For program or erase PLD only.

Table 235. ISC timing (3 V PSD module)

Symbol	Parameter	Conditions	Min	Max	Unit
t_{ISCCF}	Clock (TCK, PC1) frequency (except for PLD)	(1)		16	MHz
t_{ISCHH}	Clock (TCK, PC1) high time (except for PLD)		40		ns
t_{ISCLL}	Clock (TCK, PC1) low time (except for PLD)		40		ns
t_{ISCCFP}	Clock (TCK, PC1) frequency (PLD only)	(2)		4	MHz
t_{ISCHHP}	Clock (TCK, PC1) high time (PLD only)		90		ns
t_{ISCLLP}	Clock (TCK, PC1) low time (PLD only)		90		ns
$t_{ISCPUSU}$	ISC port setup time		12		ns
t_{ISCPHU}	ISC port hold up time		5		ns
t_{ISCPCO}	ISC port clock to output			30	ns
t_{ISCPZV}	ISC port high-impedance to valid output			30	ns
t_{ISCPVZ}	ISC port valid output to high-impedance			30	ns

1. For non-PLD programming, erase or in ISC bypass mode.
2. For program or erase PLD only.

Figure 108. MCU module AC measurement I/O waveform

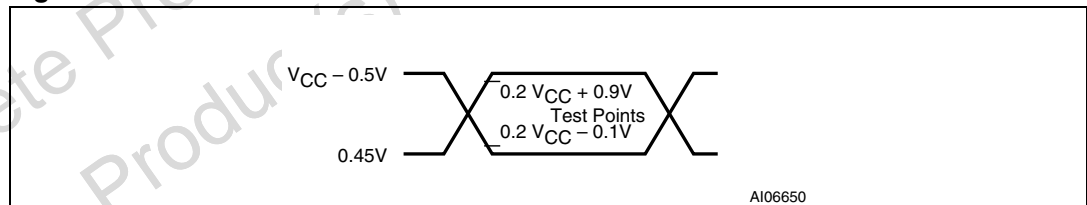

1. AC inputs during testing are driven at $V_{CC}-0.5$ V for a logic '1,' and 0.45 V for a logic '0.'
2. Timing measurements are made at $V_{IH}(\text{min})$ for a logic '1,' and $V_{IL}(\text{max})$ for a logic '0'

Figure 109. PSD module AC float I/O waveform

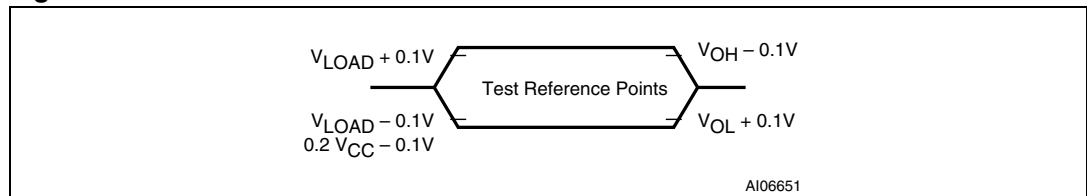

1. For timing purposes, a port pin is considered to be no longer floating when a 100 mV change from load voltage occurs, and begins to float when a 100 mV change from the loaded V_{OH} or V_{OL} level occurs
2. I_{OL} and $I_{OH} \geq 20$ mA

Figure 110. External clock cycle

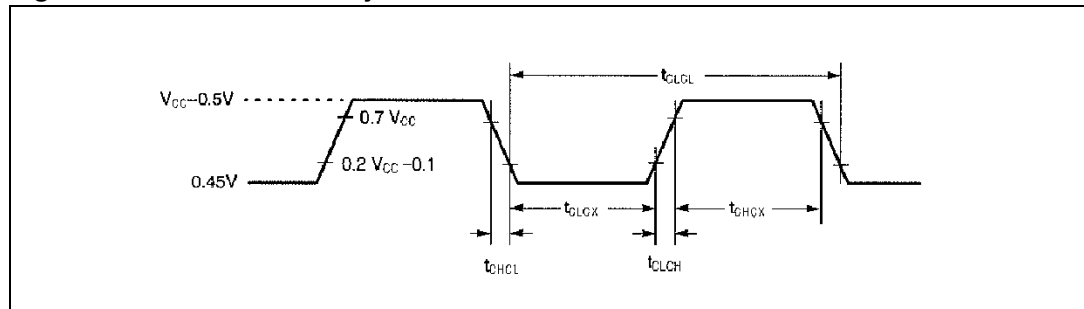

Figure 111. PSD module AC measurement I/O waveform

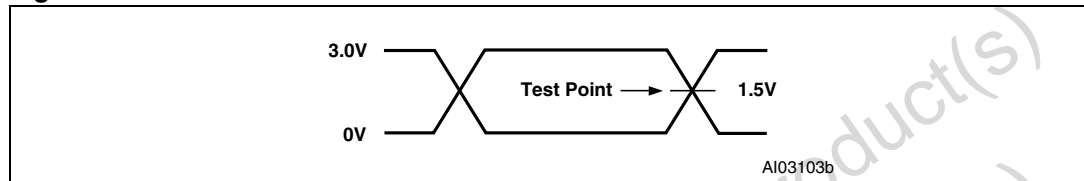

Figure 112. PSD module AC measurement load circuit

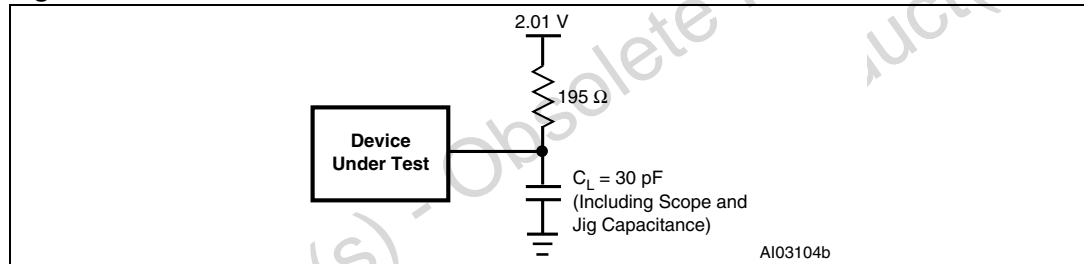

Table 236. I/O pin capacitance

Symbol	Parameter ⁽¹⁾	Test condition	Typ. ⁽²⁾	Max.	Unit
C _{IN}	Input capacitance (for input pins)	V _{IN} = 0 V	4	6	pF
C _{OUT}	Output capacitance (for input/output pins) ⁽³⁾	V _{OUT} = 0 V	8	12	pF

1. Sampled only, not 100% tested.
2. Typical values are for T_A = 25 °C and nominal supply voltages.
3. Maximum for MCU Address and Data lines is 20 pF each.

32 Package mechanical information

In order to meet environmental requirements, ST offers these devices in different grades of ECOPACK[®] packages, depending on their level of environmental compliance. ECOPACK[®] specifications, grade definitions and product status are available at: www.st.com. ECOPACK[®] is an ST trademark.

Obsolete Product(s) - Obsolete Product(s)
Obsolete Product(s) - Obsolete Product(s)

Figure 113. LQFP52 – 52-lead plastic thin, quad, flat package outline

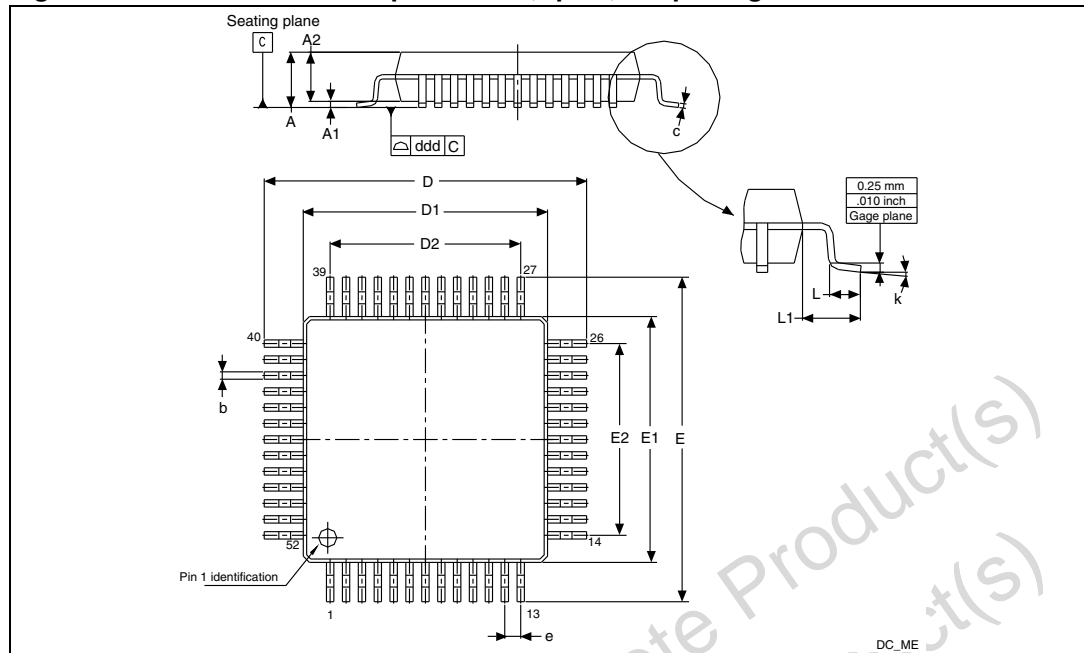

1. Drawing is not to scale.

Table 237. LQFP52 – 52-lead plastic thin, quad, flat package mechanical data

Symbol	millimeters			inches ⁽¹⁾		
	Typ	Min	Max	Typ	Min	Max
A			1.60			0.063
A1		0.05	0.15		0.002	0.0059
A2		1.35	1.45		0.0531	0.0571
b		0.22	0.38		0.0087	0.015
C		0.09	0.2		0.0035	0.0079
D	12			0.4724		
D1	10			0.3937		
D2	7.8			0.3071		
E	12			0.4724		
E1	10			0.3937		
E2	7.8			0.3071		
e	0.65			0.0256		
L		0.45	0.75		0.0177	0.0295
L1	1			0.0394		
k		0°	7°		0°	7°
ddd		0.100			0.0039	

1. Values in inches are converted from mm and rounded to 4 decimal digits.

Figure 114. LQFP80 – 80-lead plastic thin, quad, flat package outline

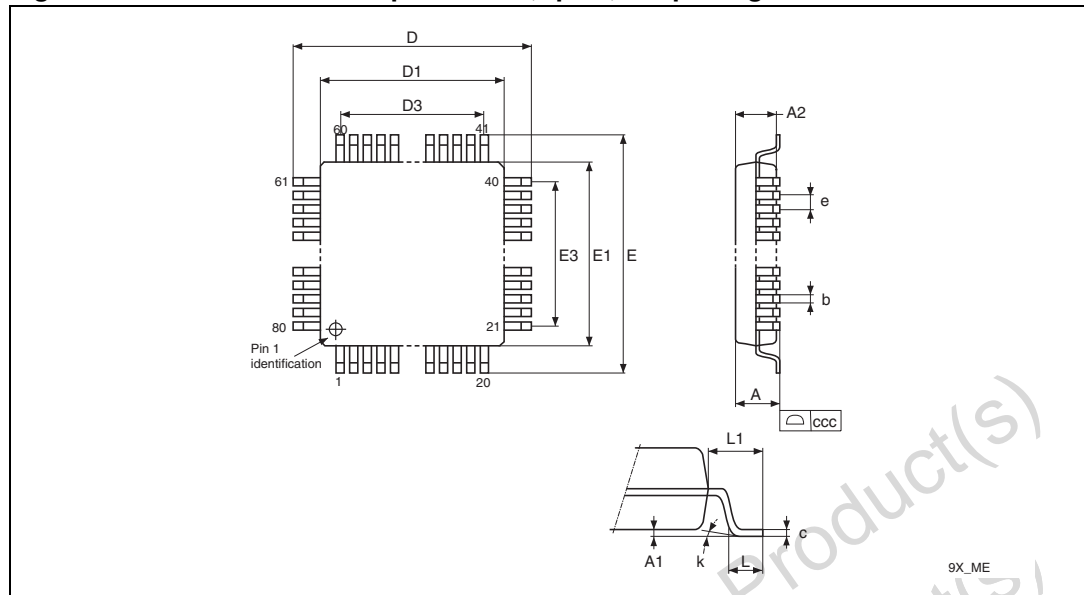

1. Drawing is not to scale.

Table 238. LQFP80 – 80-lead plastic thin, quad, flat package mechanical data

Symbol	millimeters			inches ⁽¹⁾		
	Typ	Min	Max	Typ	Min	Max
A			1.600			0.0630
A1		0.050	0.150		0.0020	0.0059
A2	1.400	1.350	1.450	0.0551	0.0531	0.0571
b	0.220	0.170	0.270	0.0087	0.0067	0.0106
C		0.090	0.200		0.0035	0.0079
D	14.000			0.5512		
D1	12.000			0.4724		
D3	9.500			0.3740		
E	14.000			0.5512		
E1	12.000			0.4724		
E3	9.500			0.3740		
e	0.500			0.0197		
L	0.600	0.450	0.750	0.0236	0.0177	0.0295
L1	1.000			0.0394		
k		0°	7°		0°	7°
ccc		0.080			0.0031	

1. Values in inches are converted from mm and rounded to 4 decimal digits.

33 Part numbering

Table 239. Ordering information scheme

Example:	UPSD	34	3	4	E	V	-	40	U	6	T
Device type uPSD = Microcontroller PSD											
Family 34 = Turbo Plus core											
SRAM size 2 = 4 Kbyte 3 = 8 Kbyte 5 = 32 Kbyte											
Main Flash memory size 2 = 64 Kbyte 3 = 128 Kbyte 4 = 256 Kbyte											
IP Mix E = IP Mix: USB, I ² C, SPI, UART (2), IrDA, ADC, Supervisor, PCA											
Operating voltage blank: V _{CC} = 3.0 to 3.6 V, V _{DD} = 4.5 to 5.5 V V: V _{CC} = V _{DD} = 3.0 to 3.6 V											
Revision “-” = Revision A B = Revision B											
Speed -40 = 40 MHz											
Package T = 52-pin LQFP ECOPACK-compliant package U = 80-pin LQFP ECOPACK-compliant package											
Temperature range 6 = -40 to 85 °C											
Shipping option Tape & reel packing = T											

For other options, or for more information on any aspect of this device, please contact the ST sales office nearest you.

Table 240. Order codes

Part number	Max MHz	1st Flash	2nd Flash	SRAM	GPIO	8032 bus	V _{CC}	V _{DD}	Package
		(bytes)							
UPSD3422E-40T6	40	64K	32K	4K	35	No	3.3 V	5.0 V	LQFP52
UPSD3422EV-40T6	40	64K	32K	4K	35	No	3.3 V	3.3 V	LQFP52
UPSD3422E-40U6	40	64K	32K	4K	46	Yes	3.3 V	5.0 V	LQFP80
UPSD3422EV-40U6	40	64K	32K	4K	46	Yes	3.3 V	3.3 V	LQFP80
UPSD3433E-40T6	40	128K	32K	8K	35	No	3.3 V	5.0 V	LQFP52
UPSD3433EV-40T6	40	128K	32K	8K	35	No	3.3 V	3.3 V	LQFP52
UPSD3433E-40U6	40	128K	32K	8K	46	Yes	3.3 V	5.0 V	LQFP80
UPSD3433EV-40U6	40	128K	32K	8K	46	Yes	3.3 V	3.3 V	LQFP80
UPSD3434E-40T6	40	256K	32K	8K	35	No	3.3 V	5.0 V	LQFP52
UPSD3434EV-40T6	40	256K	32K	8K	35	No	3.3 V	3.3 V	LQFP52
UPSD3434E-40U6	40	256K	32K	8K	46	Yes	3.3 V	5.0 V	LQFP80
UPSD3434EV-40U6	40	256K	32K	8K	46	Yes	3.3 V	3.3 V	LQFP80
UPSD3454E-40T6	40	256K	32K	32K	35	No	3.3 V	5.0 V	LQFP52
UPSD3454EV-40T6	40	256K	32K	32K	35	No	3.3 V	3.3 V	LQFP52
UPSD3454E-40U6	40	256K	32K	32K	46	Yes	3.3 V	5.0 V	LQFP80
UPSD3454EV-40U6	40	256K	32K	32K	46	Yes	3.3 V	3.3 V	LQFP80
UPSD3422EB40T6	40	64K	32K	4K	35	No	3.3 V	5.0 V	LQFP52
UPSD3422EVB40T6	40	64K	32K	4K	35	No	3.3 V	3.3 V	LQFP52
UPSD3422EB40U6	40	64K	32K	4K	46	Yes	3.3 V	5.0 V	LQFP80
UPSD3422EVB40U6	40	64K	32K	4K	46	Yes	3.3 V	3.3 V	LQFP80
UPSD3433EB40T6	40	128K	32K	8K	35	No	3.3 V	5.0 V	LQFP52
UPSD3433EVB40T6	40	128K	32K	8K	35	No	3.3 V	3.3 V	LQFP52
UPSD3433EB40U6	40	128K	32K	8K	46	Yes	3.3 V	5.0 V	LQFP80
UPSD3433EVB40U6	40	128K	32K	8K	46	Yes	3.3 V	3.3 V	LQFP80
UPSD3434EB40T6	40	256K	32K	8K	35	No	3.3 V	5.0 V	LQFP52
UPSD3434EVB40T6	40	256K	32K	8K	35	No	3.3 V	3.3 V	LQFP52
UPSD3434EB40U6	40	256K	32K	8K	46	Yes	3.3 V	5.0 V	LQFP80
UPSD3434EVB40U6	40	256K	32K	8K	46	Yes	3.3 V	3.3 V	LQFP80
UPSD3454EB40T6	40	256K	32K	32K	35	No	3.3 V	5.0 V	LQFP52
UPSD3454EVB40T6	40	256K	32K	32K	35	No	3.3 V	3.3 V	LQFP52
UPSD3454EB40U6	40	256K	32K	32K	46	Yes	3.3 V	5.0 V	LQFP80
UPSD3454EVB40U6	40	256K	32K	32K	46	Yes	3.3 V	3.3 V	LQFP80

Note: Operating temperature is in the Industrial range (−40 °C to 85 °C).



34 Important notes

The following sections describe the limitations that apply to the UPSD34xx devices and the differences between revision A and B silicon.

34.1 USB interrupts with idle mode

Description

An interrupt generated by a USB related event does not bring the MCU out of idle mode for processing.

Impact on application

Idle mode cannot be used with USB.

Workaround

Revision A - None identified at this time.

Revision B - Corrected in silicon so that a USB interrupt that occurs will bring the MCU out of idle mode.

34.2 USB reset interrupt

Description

When the MCU clock prescaler is set to a value other than $f_{MCU} = f_{OSC}$ (no division), a reset signal on the USB does not cause a USB interrupt to be generated.

Impact on application

An MCU clock other than that equal to the frequency of the oscillator cannot be used.

Workaround

Revision A - The CPUPS field in the CCON0 register must be set to 000b (default after reset). The 3400 USB firmware examples set CCON0 register to 000b.

Revision B - Corrected in silicon so that when an MCU clock prescaler is used, a reset signal on the USB does generate an interrupt.

34.3 USB reset

Description

A USB reset does not reset the USB SIE's registers.

Impact on application

A USB reset does not reset the USB SIE's registers as does a power-on or hardware reset.

Workaround

Revision A and B - When a USB reset is detected, the USB SIE's registers must be initialized appropriately by the firmware. The 3400 USB firmware examples clear USB SIE's registers if USB reset is detected.

34.4 Data toggle**Description**

The data toggle bit is read only.

Impact on application

The IN FIFO data toggle bit is controlled exclusively by the USB SIE; therefore, it is not possible to change the state of the data toggle bit by firmware.

Workaround

Revision A - For cases where the data toggle bit must be reset, such as after a Clear Feature/Stall request, sending the subsequent data on that endpoint twice results in getting the data toggle bit back to the state that it should be.

Revision B - A change in silicon was made so that the data toggle bit is reset by disabling and then enabling the respective endpoint's FIFO.

34.5 USB FIFO accessibility**Description**

The USB FIFO is only accessible by firmware and not by a JTAG debugger.

Impact on application

Using a JTAG debugger, it is not possible to view the USB FIFO's contents in a memory dump window.

Workaround

Revision A and B - None identified at this time.

34.6 Erroneous resend of data packet**Description**

When a data packet is sent the respective IN FIFO busy bit is not automatically cleared by the USB SIE. This can cause a data packet to be erroneously resent to the host in response to an IN PID immediately after the first correct transmission of this data packet.

Impact on application

Since the Data Toggle in the retransmitted data packet is toggled from when the data was first sent, the host will treat this packet as valid. If the identified workaround is not

implemented then this extra and unexpected data packet would result in a communication breakdown.

Workaround

Revision A and B - In the USB ISR, when an INx (x = the endpoint number of the IN FIFO) interrupt is detected, the IN FIFOs respective busy bit should be unconditionally cleared. The UPSD3400 USB firmware implements this workaround.

34.7 IN FIFO pairing operation

Description

When FIFO pairing is used on IN endpoints, an erroneous resend of a data packet may occur. See the "Erroneous Resend of Data Packet" note as it also applies when IN FIFO pairing is used.

Impact on application

See the "Erroneous Resend of Data Packet" note as the impact is the same when IN FIFO pairing is used.

Workaround

Revision A and B - See the "Erroneous Resend of Data Packet" note as the workaround is the same when IN FIFO pairing is used.

34.8 OUT FIFO pairing operation

Description

When data packets are received from the host and FIFO pairing is used, the paired FIFOs may get out of order.

Impact on application

The received data packets are read out of order compared to the way they were sent from the host. If the workaround is not implemented, the out of order packets would result in a communication breakdown.

Workaround

Revision A and B - In the USB ISR, when an OUTx (x = the endpoint number of the OUT FIFO) interrupt is detected, the OUT FIFOs respective busy bit should be unconditionally cleared. The UPSD3400 USB firmware implements this workaround.

34.9 Missing ACK to host retransmission of SETUP packet

Description

If a host does not properly receive the ACK (due to noise) from the UPSD3400 in response to a SETUP packet, it will resend the SETUP packet but the UPSD3400 will not respond

with an ACK. The host will resend the SETUP packet a number of times and if an ACK is not received from the UPSD3400, the host will issue a USB reset and then enumerate it again. Upon detecting a USB reset, the UPSD3400 firmware will reset and initialize the USB SIE putting the hardware back into the reset/initialized state so that when the next SETUP packet is received, the UPSD3400 will respond with an ACK to the host.

Impact on application

If this occurs during enumeration, the impact is minimal as the host will retry the enumeration. If it happens after enumeration, the communication will break down between the host application and the UPSD3400 and will need to be re-established after the UPSD3400 is reset and enumerated again. In extremely noisy environments, the UPSD3400 may not communicate well over USB with the host application.

Workaround

Revision A and B - None identified at this time.

34.10 MCU JTAG ID

Description

MCU JTAG ID changed to differentiate revision A from revision B silicon through the JTAG port. The PSD JTAG ID remains the same.

Revision A MCU JTAG ID - 0451F041f

Revision B MCU JTAG ID - 1451F041h

Impact on application

There will be no impact on the application. The impact will be to JTAG production programming equipment that may need to distinguish between revision A and B MCU silicon if the firmware is different depending on the revision level.

34.11 Port 1 not 5-volt IO tolerant

Description

The port P1 is shared with the ADC module and as a result Port P1 is not 5 V tolerant.

Impact on application

5 V devices should not be connected to port P1.

Workaround

Revision A and B - Peripherals or GPIO that require 5-Volt IO tolerance should be mapped to Port 3 or Port 4.

34.12 Incorrect code execution when code banks are switched

Description

When a code bank is switched, the PFQ/BC contain values from the previously selected bank and are not automatically flushed and reloaded from the newly selected code bank.

Impact on application

Depending on the contents of the PFQ/BC when the code bank is switched, improper code execution may result.

Workaround

The PFQ/BC must be flushed when the code bank is changed. Disabling and re-enabling the PFQ/BC will flush them. The following instructions are an example of how to flush the PFQ/BC:

```
ANL  BUSCON,#03Fh ;Disable PFQ/BC
```

```
ORL  BUSCON,#0C0h ;Enable PFQ/BC
```

Bank switching is typically handled by tool vendors in a file called I51_bank.a51. The uPSD tools offered by Keil and Raisonance now include an updated version of I51_bank.a51 for the uPSD products that flushes the PFQ/BC. The most recent banking examples available from ST's website include the updated I51_bank.a51 files.

34.13 9th received data bit corrupted in UART modes 2 and 3

Description

If the 9th transmit data bit is written by firmware into TB8 at the same time as a received 9th bit is being written by the hardware into RB8, RB8 is not correctly updated. This applies to both UART0 and UART1. Typically, the 9th data bit is used as a parity bit to check for data transmission errors on a byte by byte basis.

Impact on application

UART Modes 2 and 3 can't be used reliably in full-duplex mode.

Workaround

Revision A and B - Some options include:

1. Only use Mode 1 (8 data bits) for full-duplex communication.
2. Use Mode 1 and a packet based communication protocol with a checksum or CRC to detect data transmission errors.
3. Use UART0 in mode 2 or 3 for transmitting data and UART1 in mode 2 or 3 for receiving data.
4. Use some form of handshaking to ensure that data is never transmitted and received simultaneously on a single UART configured in mode 2 or 3.

35 Revision history

Table 241. Document revision history

Date	Version	Revision details
04-Feb-2005	1	First Edition
30-Mar-2005	2	Added one note in Section 1: Description on page 20 Added two notes in Section 25: USB interface on page 150 Changed values in Table 230 on page 285 (Turbo Off column) Added Section 34: Important notes on page 294
25-Oct-2005	3	Changed Table on page 293 to add sales types with 32K SRAM Changed Figure 1 on page 21 Changed Figure 5 on page 30 Corrected Port Pin P1.5 from ADC6 to ADC5 in Table 2 on page 24 Removed duplicate entry for 80-pin no. 11 in Table 2 on page 24 Changed Figure 61 on page 191 Updated Table 157 on page 193 Updated Table 239 on page 292
11-Jul-2006	4	Pin descriptions, Figure 2 on page 22 and Figure 3 updated with V_{REF} changed to AV_{REF} V_{REF} changed to AV_{REF} throughout document Figure 13 updated, correcting CCON[2:0] Clarification of V_{CC} , V_{DD} , AV_{CC} supply voltages in section Section 30: Maximum rating on page 268 Section 34: Important notes updated with differences between silicon revisions A and B, and new Important Notes added. SPI Master Controller corrected to 10MHz in features on first page Latched address out modified, adding A8-A15 to PB0-PB7, Section Table 2.: Pin definitions UCON register reset value changed from 00h to 08h throughout Reference to USBCE bit corrected to UPLLCE Section 14 on page 68 Incorrect references to UART#2 changed to UART#1 Section 22.1 on page 120 UADDR register description enhanced, Table 100 on page 162 USB interrupts section text expanded, Section 25.4.3 on page 163 UIFO register table modified, Table 112 on page 166 UCTL register table enhanced, Table 120 on page 170 Note added below Table 122 on page 171 Many modifications made to UCON register description, Table 126 on page 173 An incorrect reference to CAPCOMHn changed to CAPCOMLn Section 27.7 on page 184 Part numbering guide updated with B revision information Section 33 on page 292 Figure 40 on page 123 updated Document reformatted Note added related to non-support of external indirect addressing, in Section 9.6 and in Table 8 on page 54
26-Jan-2009	5	SRAM standby mode removed. Backup battery feature removed. All products are delivered in ECOPACK-compliant packages. Section 32: Package mechanical information on page 289 updated. Small text changes including part number capitalization.

Please Read Carefully:

Information in this document is provided solely in connection with ST products. STMicroelectronics NV and its subsidiaries ("ST") reserve the right to make changes, corrections, modifications or improvements, to this document, and the products and services described herein at any time, without notice.

All ST products are sold pursuant to ST's terms and conditions of sale.

Purchasers are solely responsible for the choice, selection and use of the ST products and services described herein, and ST assumes no liability whatsoever relating to the choice, selection or use of the ST products and services described herein.

No license, express or implied, by estoppel or otherwise, to any intellectual property rights is granted under this document. If any part of this document refers to any third party products or services it shall not be deemed a license grant by ST for the use of such third party products or services, or any intellectual property contained therein or considered as a warranty covering the use in any manner whatsoever of such third party products or services or any intellectual property contained therein.

UNLESS OTHERWISE SET FORTH IN ST'S TERMS AND CONDITIONS OF SALE ST DISCLAIMS ANY EXPRESS OR IMPLIED WARRANTY WITH RESPECT TO THE USE AND/OR SALE OF ST PRODUCTS INCLUDING WITHOUT LIMITATION IMPLIED WARRANTIES OF MERCHANTABILITY, FITNESS FOR A PARTICULAR PURPOSE (AND THEIR EQUIVALENTS UNDER THE LAWS OF ANY JURISDICTION), OR INFRINGEMENT OF ANY PATENT, COPYRIGHT OR OTHER INTELLECTUAL PROPERTY RIGHT.

UNLESS EXPRESSLY APPROVED IN WRITING BY AN AUTHORIZED ST REPRESENTATIVE, ST PRODUCTS ARE NOT RECOMMENDED, AUTHORIZED OR WARRANTED FOR USE IN MILITARY, AIR CRAFT, SPACE, LIFE SAVING, OR LIFE SUSTAINING APPLICATIONS, NOR IN PRODUCTS OR SYSTEMS WHERE FAILURE OR MALFUNCTION MAY RESULT IN PERSONAL INJURY, DEATH, OR SEVERE PROPERTY OR ENVIRONMENTAL DAMAGE. ST PRODUCTS WHICH ARE NOT SPECIFIED AS "AUTOMOTIVE GRADE" MAY ONLY BE USED IN AUTOMOTIVE APPLICATIONS AT USER'S OWN RISK.

Resale of ST products with provisions different from the statements and/or technical features set forth in this document shall immediately void any warranty granted by ST for the ST product or service described herein and shall not create or extend in any manner whatsoever, any liability of ST.

ST and the ST logo are trademarks or registered trademarks of ST in various countries.

Information in this document supersedes and replaces all information previously supplied.

The ST logo is a registered trademark of STMicroelectronics. All other names are the property of their respective owners.

© 2009 STMicroelectronics - All rights reserved



STMicroelectronics group of companies

Australia - Belgium - Brazil - Canada - China - Czech Republic - Finland - France - Germany - Hong Kong - India - Israel - Italy - Japan - Malaysia - Malta - Morocco - Singapore - Spain - Sweden - Switzerland - United Kingdom - United States of America







www.st.com

Looking for pricing, stock, or lifecycle information?

Click below to explore more details on WIN SOURCE:

-  [View UPSD3434E-40U6 on WIN SOURCE](#)
-  [STMicroelectronics](#) Information

Optimize Your Supply Chain with WIN SOURCE Solutions

-  Global Sourcing Solution
-  Obsolete Management
-  Cost Control Management
-  Shortage Management
-  Alternative Solution
-  Excess Inventory Management