



**THE DATASHEET OF
UM3486EESA**



***3V to 5.5V-Powered, ±15kV ESD-Protected,
Slew-Rate-Limited, True RS-485 Transceivers***

UM3483E/UM3486E SOP8/DIP8

General Description

The UM3483E, UM3486E are 3V to 5.5V-powered, ±15kV ESD-protected, slew-rate-limited differential transceivers which provide full RS485 compatibility. Each part contains one driver and one receiver, which is designed for data transmission with extended common mode range (-7V to 12V). The UM3483E features slew-rate-limited driver which minimizes EMI and reduces reflections resulted from improperly terminated cables. The UM3483E allows up to 500kbps error-free data transmission, while the partially slew-rate-limited UM3486E transmits at data rates up to 2.5Mbps.

The UM3483E, UM3486E also feature enhanced electrostatic discharge (ESD) protection. All of the transmitter outputs and receiver inputs are protected to ±15kV using IEC61000-4-2 Air-Gap Discharge, ±15kV using the Human Body Model and ±8kV using IEC61000-4-2 Contact Discharge.

Drivers are short-circuit current limited. When the driver outputs are placed into a high-impedance state by thermal shutdown circuitry, drivers are protected against excessive power dissipation. And the fail-safe feature of the receiver input guarantees a logic-high output if both inputs are open, shorted or idle.

Both parts have power up/down mode, the glitch-free driver outputs permit live insertion or removal of the transceiver into/from the data bus. The CMOS design offers significant power savings without sacrificing ruggedness against overload or ESD damage. The typical quiescent current is only 300µA during operation and 1µA in shutdown mode.

The UM3483E, UM3486E are intended for half-duplex communication and are available in SOP8 and DIP8 packages.

Applications

- Telecommunications
- Low-Power RS-485 Transceivers
- Integrated Services Digital Networks
- Industrial-Control Local Area Networks
- Transceivers for EMI-Sensitive Applications
- Packet Switching
- Level Translators

Features

- ESD Protection for RS-485 I/O Pins
 - ±15kV—Human Body Model
 - ±15kV—IEC61000-4-2, Air-Gap Discharge
 - ±8kV—IEC61000-4-2, Contact Discharge
- 3V to 5.5V Supply Voltage Range
- Enhanced Slew-Rate Limiting Facilitates Error-Free Data Transmission
- 1µA Low-Current Shutdown Mode
- -7V to +12V Common-Mode Input Voltage Range
- Allows up to 256 Transceivers on the Bus
- Thermal Shutdown
- Current-Limiting for Driver Overload Protection

Ordering Information

Part Number	Operating Temperature	Mark Code	Package Type	Shipping Qty
UM3483EESA	-40°C to +85°C	UM3483EESA	SOP8	3000pcs/13 Inch Tape & Reel
UM3483EEPA	-40°C to +85°C	UM3483EEPA	DIP8	50pcs/Tube
UM3486EESA	-40°C to +85°C	UM3486EESA	SOP8	3000pcs/13 Inch Tape & Reel
UM3486EEPA	-40°C to +85°C	UM3486EEPA	DIP8	50pcs/Tube

Selection Guide

Part Number	Guaranteed Data Rate (Mbps)	Low-Power Shutdown	Slew-Rate Limited	Driver/Receiver Enable	Shutdown Current (μA)	Transceivers On Bus	±15kV ESD Protection
UM3483E	0.5	Yes	Yes	Yes	1	256	Yes
UM3486E	2.5	Yes	Yes	Yes	1	256	Yes

Pin Configurations

Top View

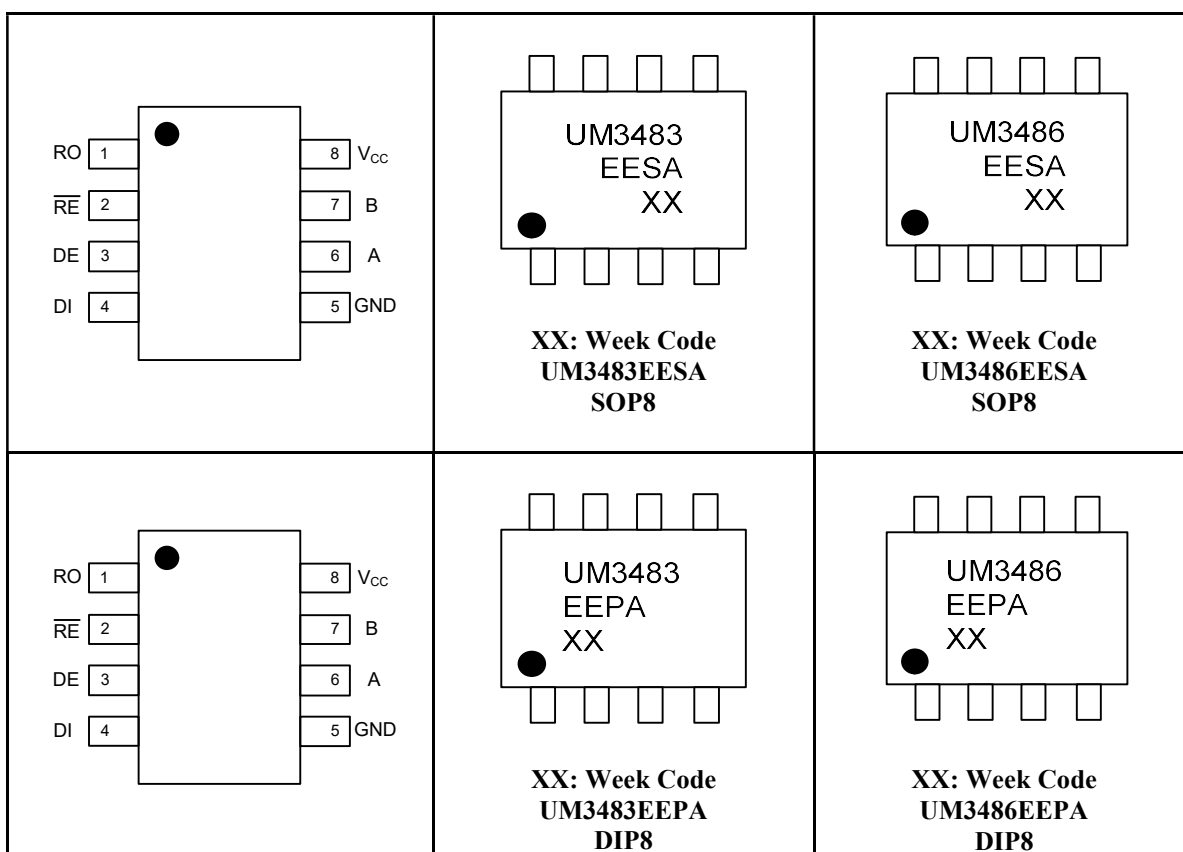

Absolute Maximum Ratings

Symbol	Parameter	Value	Unit	
V_{CC}	Supply Voltage	+7	V	
	Control Input Voltage (/RE, DE)	-0.3V to ($V_{CC} + 0.3V$)	V	
	Driver Input Voltage (DI)	-0.3V to ($V_{CC} + 0.3V$)	V	
	Driver Output Voltage (A, B)	-7 to +12	V	
	Receiver Input Voltage (A, B)	-7 to +12	V	
	Receiver Output Voltage (RO)	-0.3V to ($V_{CC} + 0.3V$)	V	
P_D	Continuous Power Dissipation at $T_A = 70^\circ C$	DIP8	727	mW
		SOP8	471	
T_A	Ambient Temperature	-40 to +85	$^\circ C$	
T_{STG}	Storage Temperature Range	-65 to +160	$^\circ C$	
T_L	Lead Temperature for Soldering 10 seconds	+300	$^\circ C$	

DC Electrical Characteristics

($V_{CC} = +3V$ to $5.5V$, $T_A = T_{MIN}$ to T_{MAX} , unless otherwise noted. Typical values are at $T_A = +25^\circ C$.)

Parameter	Symbol	Test Conditions	Min	Typ	Max	Unit		
SUPPLY CURRENT								
Supply Current	I_{CC}	No load, DI = GND or V_{CC}	DE= V_{CC} , /RE=0V or V_{CC}	0.15		1	mA	
			DE=0V, /RE=0V	0.15		1		
Supply Current in Shutdown Mode	I_{SHDN}	DE=0V, /RE= V_{CC} , DI= V_{CC} or 0V			1	μA		
LOGIC								
Input High Voltage	V_{IH}	DE, DI, /RE	2.0			V		
Input Low Voltage	V_{IL}	DE, DI, /RE			0.8	V		
Logic Input Current	I_{IN1}	DE, DI, /RE			1	μA		
Driver								
Differential Driver Output	V_{OD}	No Load Figure 1	$V_{CC}=3.3V$			3.3	V	
			$V_{CC}=5V$			5		
		$R_L=54\Omega$ Figure 1	$V_{CC}=3.3V$	1.2				
			$V_{CC}=5V$	1.5				
		$R_L=60\Omega$ Figure 1	$V_{CC}=3.3V$	1.3				
			$V_{CC}=5V$	1.5				
Change in Magnitude of Driver Differential Output Voltage for Complementary Output States (Note 1)	ΔV_{OD}	$R_L=54\Omega$ or 100Ω , Figure 1			0.2	V		
Driver Common-Mode Output Voltage	V_{OC}	$R_L=54\Omega$ or 100Ω , Figure 1			3	V		
Change in Magnitude of Common-Mode Output Voltage (Note 1)	ΔV_{OC}	$R_L=54\Omega$ or 100Ω , Figure 1			0.2	V		
Driver Short-Circuit Output Current	I_{OSD}	$V_{OUT} = -7V$			-250	mA		
		$V_{OUT} = 12V$			+250			

DC Electrical Characteristics (Continued)

($V_{CC} = +3V$ to $5.5V$, $T_A = T_{MIN}$ to T_{MAX} , unless otherwise noted. Typical values are at $T_A = +25^{\circ}C$.)

Parameter	Symbol	Test Conditions	Min	Typ	Max	Unit
RECEIVER						
Receiver Differential Threshold Voltage	V_{TH}	$-7V \leq V_{CM} \leq 12V$	-0.2	-0.05	0.2	V
Receiver Input Hysteresis	ΔV_{TH}	$V_{CM} = 0V$		25		mV
Receiver Input Resistance	R_{IN}	$-7V \leq V_{CM} \leq 12V$	96			k Ω
Input Current (A, B)	I_{IN2}	DE=0V, $V_{CC} = 0V$ or $+3V$ to $5.5V$	$V_{IN} = 12V$		1	mA
			$V_{IN} = -7V$		-0.8	
Receiver Output High Voltage	V_{OH}	$I_{OUT} = -1.5mA$, $V_{ID} = 200mV$, Figure 2	$V_{CC} - 1.5$			V
Receiver Output Low Voltage	V_{OL}	$I_{OUT} = 2.5mA$, $V_{ID} = 200mV$, Figure 2			0.4	V
Three-State (High Impedance) Output Current at Receiver	I_{OZR}	$0V \leq V_{OUT} \leq V_{CC}$			1	μA
Receiver Short-Circuit Output Current	I_{OSR}	$0V \leq V_{RO} \leq V_{CC}$	± 20		± 60	mA
ESD Protection						
ESD Protection for A, B		Human Body Model		± 15		kV
		IEC61000-4-2 Air Discharge		± 15		
		IEC61000-4-2 Contact Discharge		± 8		

Driver Switching Characteristics (UM3483E)

 (V_{CC} = +3V to 5.5V, T_A = +25°C.)

Parameter	Symbol	Test Conditions	Min	Typ	Max	Unit
Maximum Data Rate	f _{MAX}			500		kbps
Driver Differential Output Delay	t _{DD}	R _L =60Ω, Figure 3	250	500	1000	ns
Driver Differential Output Transition Time	t _{TD}	R _L =60Ω, Figure 3	250	500	750	ns
Driver Propagation Delay, Low-to-High Level	t _{PLH}	R _L =27Ω, Figure 4	250	550	1000	ns
Driver Propagation Delay, High-to-Low Level	t _{PHL}	R _L =27Ω, Figure 4	250	550	1000	ns
t _{PLH} – t _{PHL} Driver Propagation Delay Skew (Note 2)	t _{PDS}	R _L =27Ω, Figure 4		10	30	ns
Driver-Output Enable/Disable Times						
Driver Output Enable Time to Low Level	t _{PZL}	R _L =110Ω, Figure 6		100	2500	ns
Driver Output Enable Time to High Level	t _{PZH}	R _L =110Ω, Figure 5		100	2500	ns
Driver Output Disable Time from High Level	t _{PHZ}	R _L =110Ω, Figure 5		100	100	ns
Driver Output Disable Time from Low Level	t _{PLZ}	R _L =110Ω, Figure 6		100	100	ns
Driver Output Enable Time from Shutdown to Low Level	t _{PSL}	R _L =110Ω, Figure 6		500	2500	ns
Driver Output Enable Time from Shutdown to High Level	t _{PSH}	R _L =110Ω, Figure 5		500	2500	ns

Driver Switching Characteristics (UM3486E)

 (V_{CC} = +3V to 5.5V, T_A = +25°C.)

Parameter	Symbol	Test Conditions	Min	Typ	Max	Unit
Maximum Data Rate	f _{MAX}			2500		kbps
Driver Differential Output Delay	t _{DD}	R _L =60Ω, Figure 3	20	50	100	ns
Driver Differential Output Transition Time	t _{TD}	R _L =60Ω, Figure 3	20	50	100	ns
Driver Propagation Delay, Low-to-High Level	t _{PLH}	R _L =27Ω, Figure 4	25	55	100	ns
Driver Propagation Delay, High-to-Low Level	t _{PHL}	R _L =27Ω, Figure 4	25	55	100	ns
t _{PLH} – t _{PHL} Driver Propagation Delay Skew (Note 2)	t _{PDS}	R _L =27Ω, Figure 4		2	10	ns
Driver-Output Enable/Disable Times						
Driver Output Enable Time to Low Level	t _{PZL}	R _L =110Ω, Figure 6		60	100	ns
Driver Output Enable Time to High Level	t _{PZH}	R _L =110Ω, Figure 5		60	100	ns
Driver Output Disable Time from High Level	t _{PHZ}	R _L =110Ω, Figure 5		60	100	ns
Driver Output Disable Time from Low Level	t _{PLZ}	R _L =110Ω, Figure 6		60	100	ns
Driver Output Enable Time from Shutdown to Low Level	t _{PSL}	R _L =110Ω, Figure 6		500	800	ns
Driver Output Enable Time from Shutdown to High Level	t _{PSH}	R _L =110Ω, Figure 5		500	800	ns

Receiver Switching Characteristics

 (V_{CC} = +3V to 5.5V, T_A = +25°C.)

Parameter	Symbol	Test Conditions	Min	Typ	Max	Unit
Time to Shutdown	t _{SHDN}	UM3483E/UM3486E (Note 3)	50	200	600	ns
Receiver Propagation Delay, Low-to-High Level	t _{RPLH}	V _{ID} =0 to 3.0V, C _L =15pF, Figure 7		100	200	ns
		UM3483E				
Receiver Propagation Delay, High-to-Low Level	t _{RPHL}	V _{ID} =0 to 3.0V, C _L =15pF, Figure 7		100	200	ns
		UM3483E				
t _{RPLH} – t _{RPHL} Receiver Propagation Delay Skew	t _{RPDS}	V _{ID} =0 to 3.0V, C _L =15pF, Figure 7			30	ns
		UM3483E				
Receiver Output Enable Time to Low Level	t _{PRZL}	C _L =15pF, Figure 8, UM3483E/UM3486E		20	100	ns
Receiver Output Enable Time to High Level	t _{PRZH}	C _L =15pF, Figure 8, UM3483E/UM3486E		20	100	ns
Receiver Output Disable Time from High Level	t _{PRHZ}	C _L =15pF, Figure 8, UM3483E/UM3486E		30	200	ns
Receiver Output Disable Time from Low Level	t _{PRLZ}	C _L =15pF, Figure 8, UM3483E/UM3486E		30	200	ns
Receiver Output Enable Time from Shutdown to Low Level	t _{PRSL}	C _L =15pF, Figure 8, UM3483E/UM3486E		20	100	ns
Receiver Output Enable Time from Shutdown to High Level	t _{PRSH}	C _L =15pF, Figure 8, UM3483E/UM3486E		20	100	ns

Note 1: ΔV_{OD} and ΔV_{OC} are the changes in V_{OD} and V_{OC}, respectively, when the DI input changes state.

Note 2: Measured on | t_{PLH} (A) – t_{PHL} (A) | and | t_{PLH} (B) – t_{PHL} (B) |.

Note 3: The transceivers are put into shutdown by bringing /RE high and DE low. If the inputs are in this state for less than 80ns, the parts are guaranteed not to enter shutdown. If the inputs are in this state for at least 300ns, the parts are guaranteed to have entered shutdown. See Low-Power Shutdown Mode section.

Typical Operating Characteristics

($V_{CC}=+3.3V$, $T_A=+25^\circ C$, unless otherwise noted.)

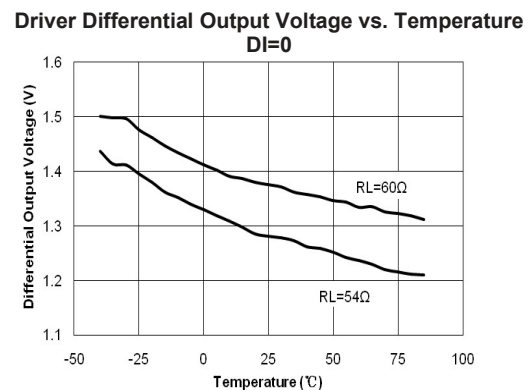
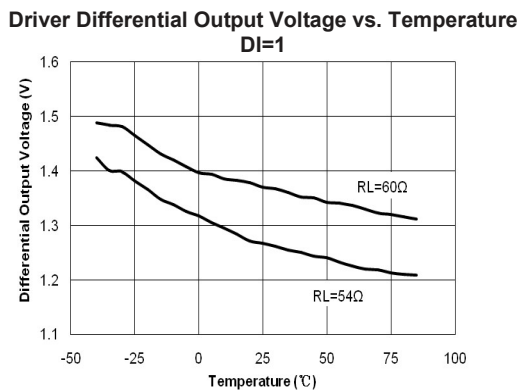
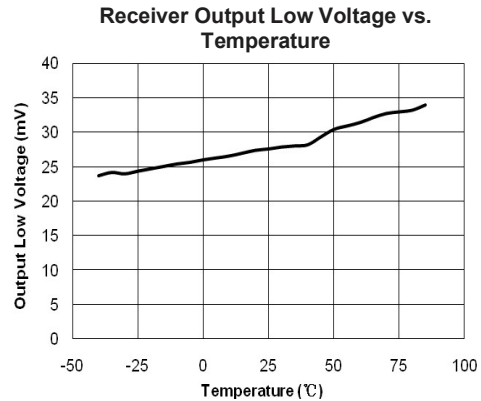
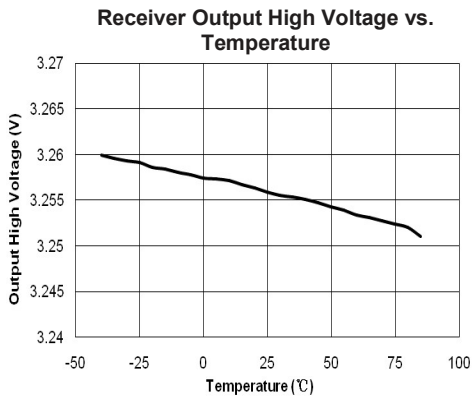
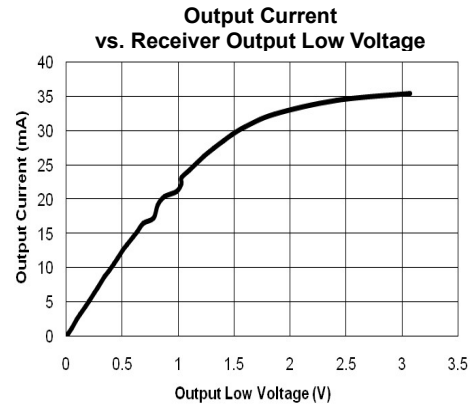
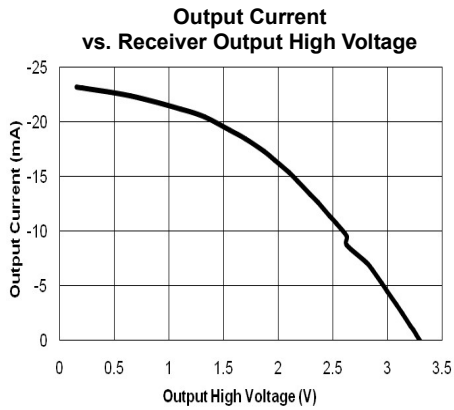
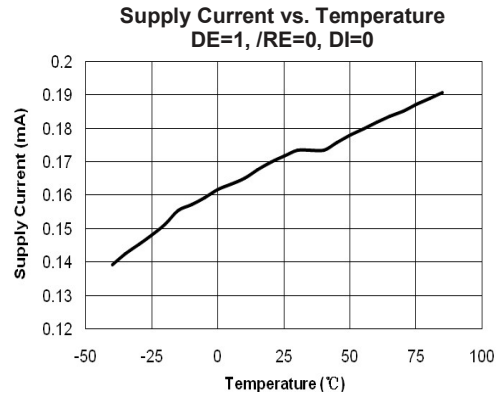
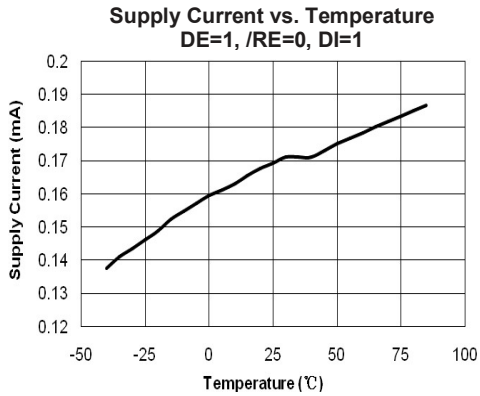

Typical Operating Characteristics (Continued)

($V_{CC}=+3.3V$, $T_A=+25^{\circ}C$, unless otherwise noted.)

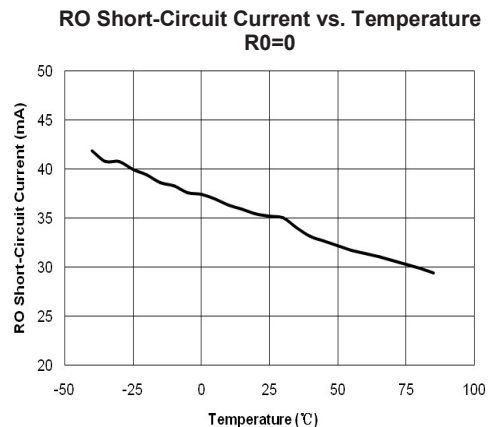
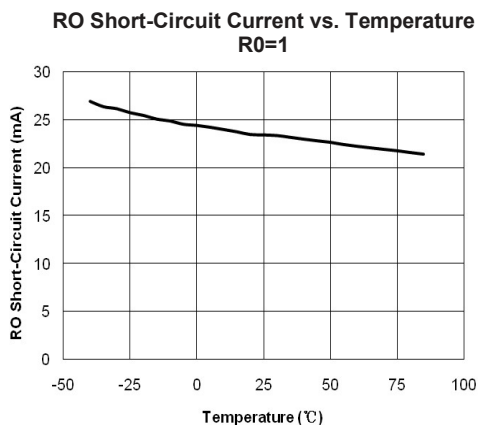
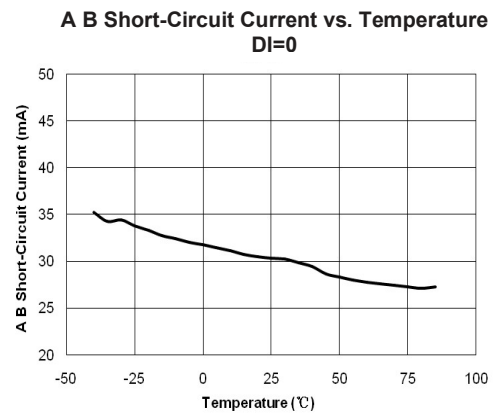
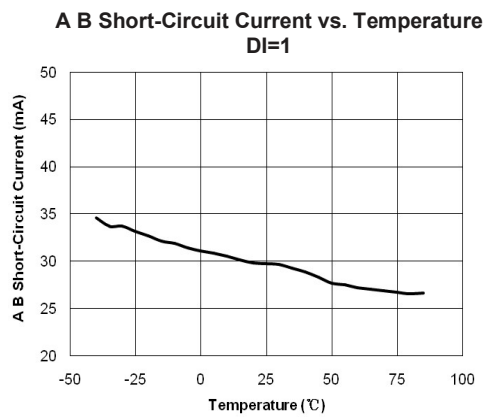
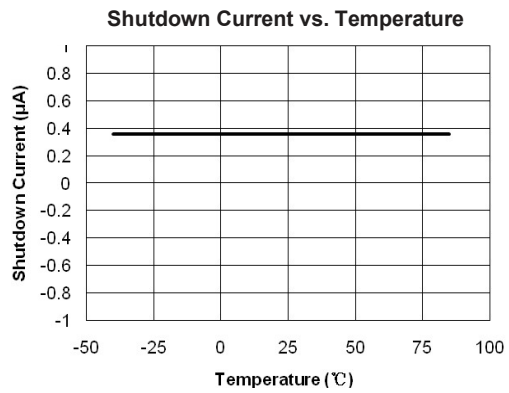
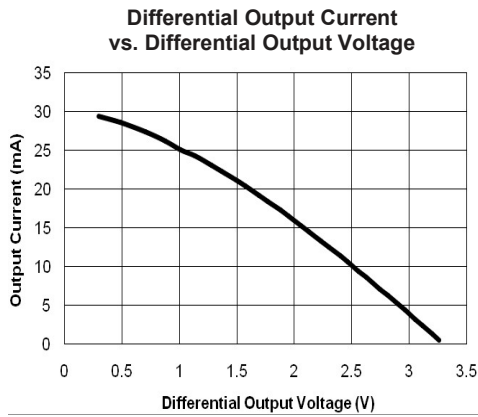

Typical Operating Characteristics (Continued)

($V_{CC}=+5.0V$, $T_A=+25^\circ C$, unless otherwise noted.)

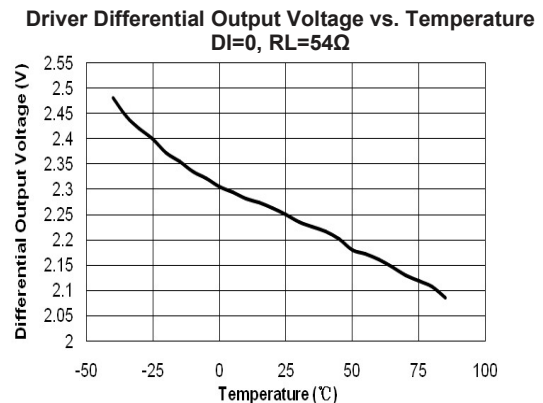
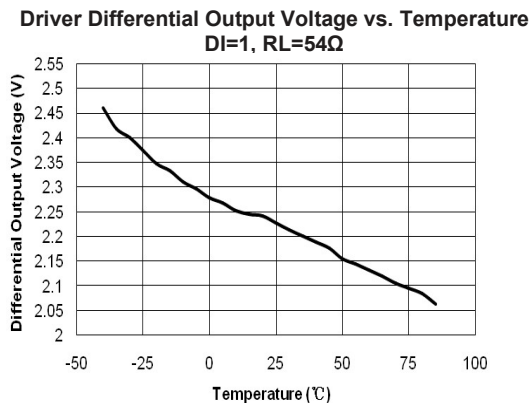
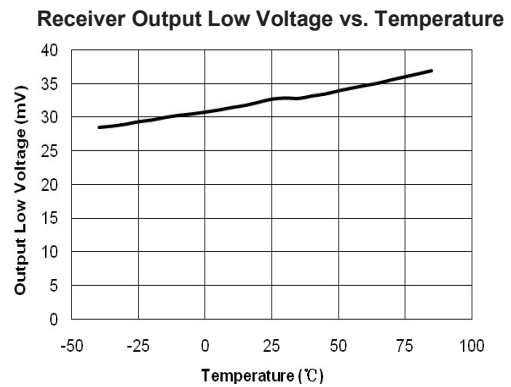
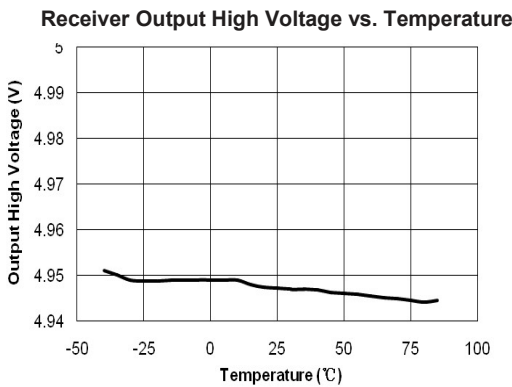
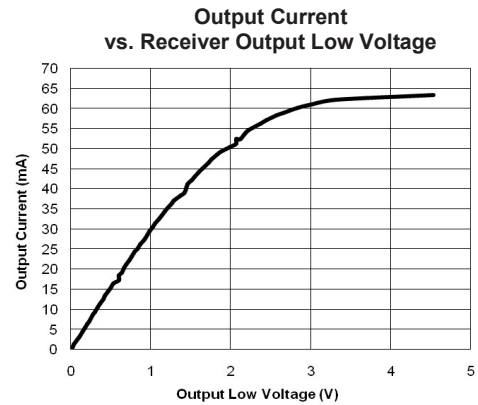
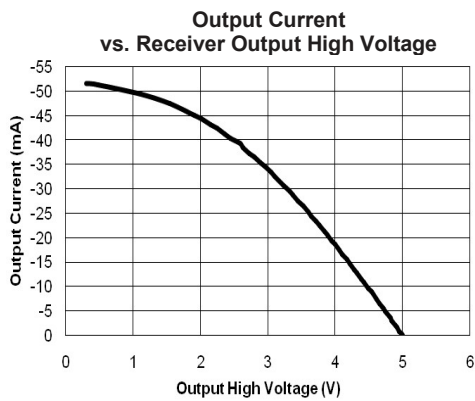
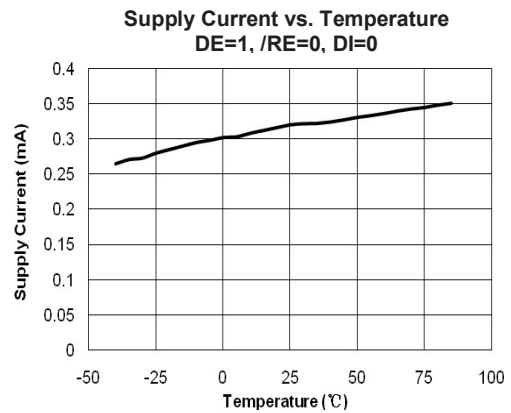
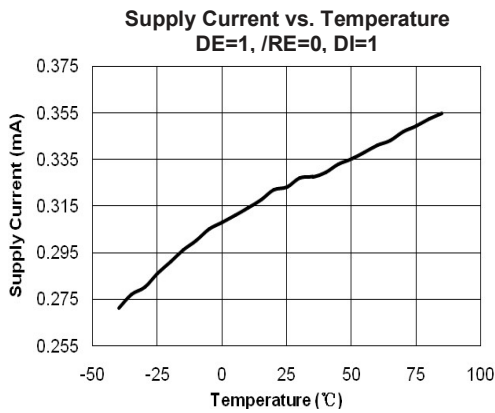

Typical Operating Characteristics (Continued)

($V_{CC}=+5.0V$, $T_A=+25^{\circ}C$, unless otherwise noted.)

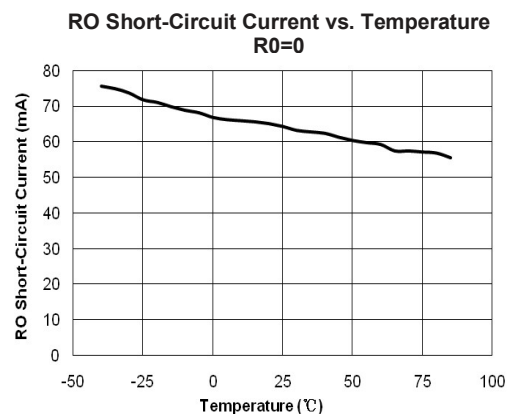
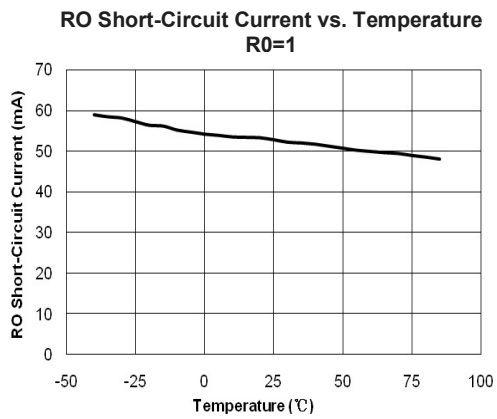
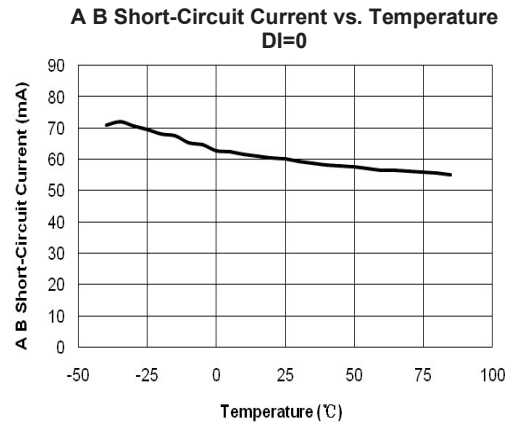
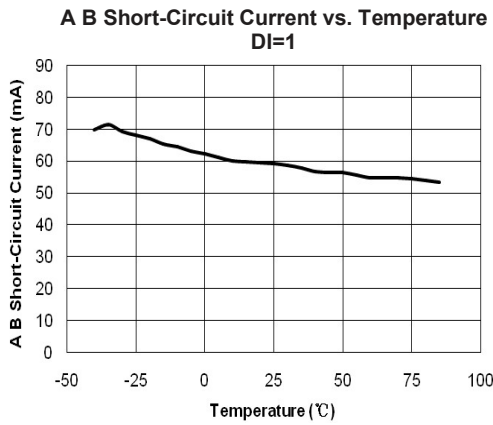
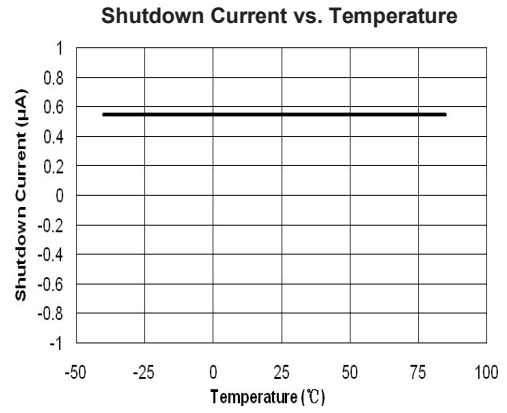
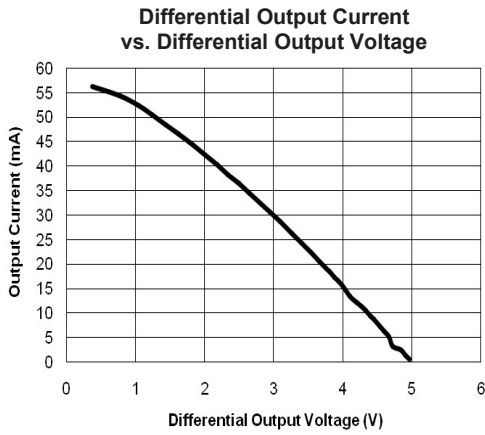

Pin Description

Pin Number	Symbol	Function
1	RO	Receiver Output. If $A > B$ by -50mV , RO will be high; if $A < B$ by 200mV , RO will be low.
2	$\overline{\text{RE}}$	Receiver Output Enable. RO is enabled when $\overline{\text{RE}}$ is low; RO is high impedance when $\overline{\text{RE}}$ is high. Drive $\overline{\text{RE}}$ high and DE low to enter low-power shutdown mode.
3	DE	Driver Output Enable. The driver outputs are enabled by bringing DE high. They are high impedance when DE is low. If $\overline{\text{RE}}$ is high and DE is low, the device will enter a low-power shutdown mode. If the driver outputs are enabled, the parts function as line drivers. While they are high impedance, they function as line receivers if $\overline{\text{RE}}$ is low.
4	DI	Driver Input. A low on DI forces output A low and output B high. Similarly, a high on DI forces output A high and output B low.
5	GND	Ground
6	A	Non-inverting Receiver Input and Non-inverting Driver Output
7	B	Inverting Receiver Input and Inverting Driver Output.
8	V_{CC}	Positive Supply: $3.0\text{V} \leq V_{\text{CC}} \leq 5.5\text{V}$

RS-485 Communication Function Table
Table1. Transmitting

INPUTS			OUTPUTS		MODE
$\overline{\text{RE}}$	DE	DI	B	A	
X	1	1	0	1	Normal
X	1	0	1	0	Normal
0	0	X	High-Z	High-Z	Normal
1	0	X	High-Z	High-Z	Shutdown

X=Don't care; High-Z=High impedance

Table2. Receiving

INPUTS			OUTPUTS	MODE
$\overline{\text{RE}}$	DE	A, B	RO	
0	X	$>-50\text{mV}$	1	Normal
0	X	$<-200\text{mV}$	0	Normal
0	X	Inputs Open	1	Normal
1	0	X	High-Z	Shutdown

X=Don't care; High-Z=High impedance

Test Circuit

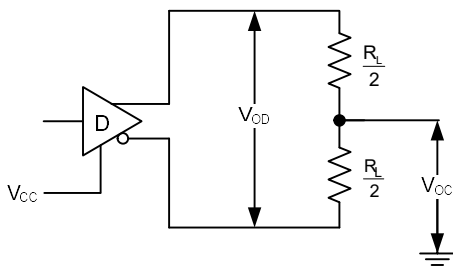

Figure 1. Driver V_{OD} and V_{OC}

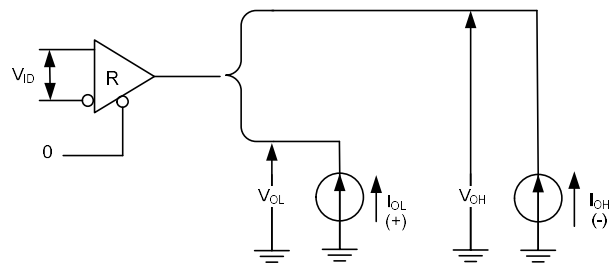

Figure 2. Receiver V_{OH} and V_{OL}

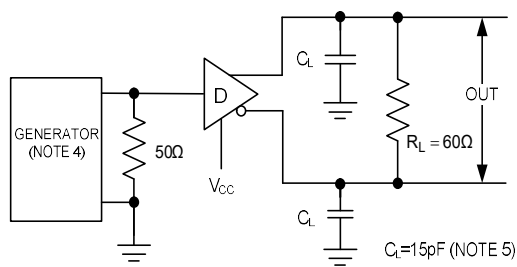

Figure 3. Driver Differential Output Delay and Transition Times

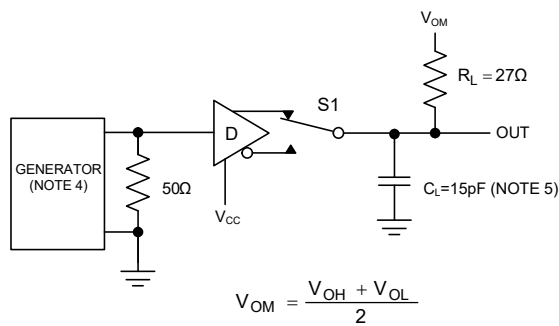
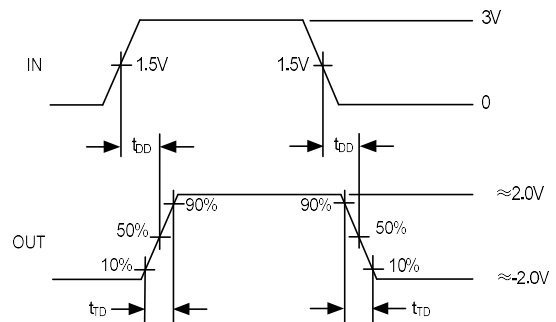

Figure 4. Driver Propagation Times

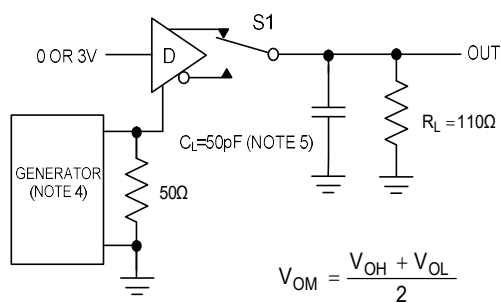
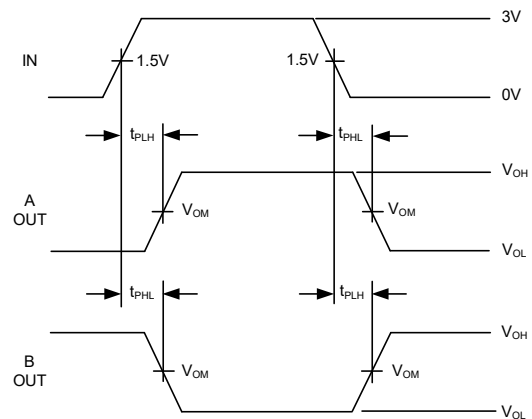
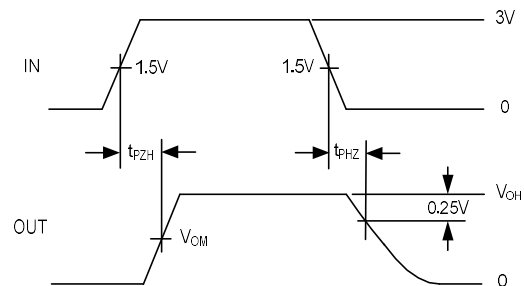

Figure 5. Driver Enable and Disable Times (t_{PZH} , t_{PSH} , t_{PHZ})



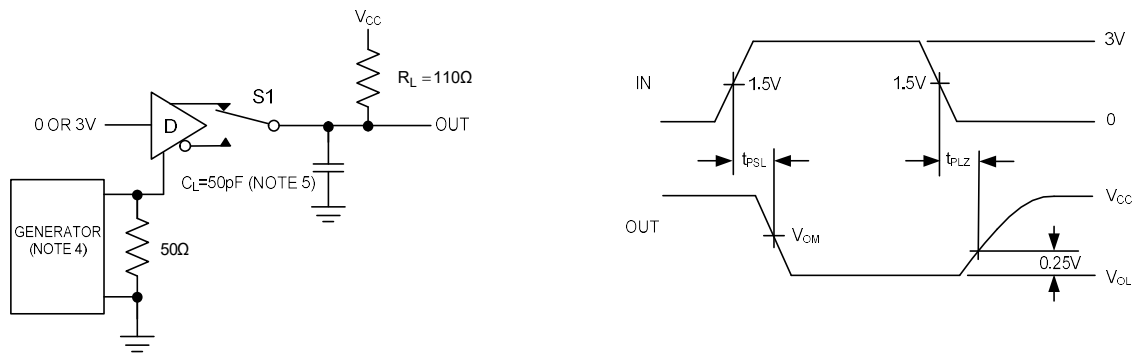

Figure 6. Driver Enable and Disable Times (t_{PZL} , t_{PSL} , t_{PLZ})

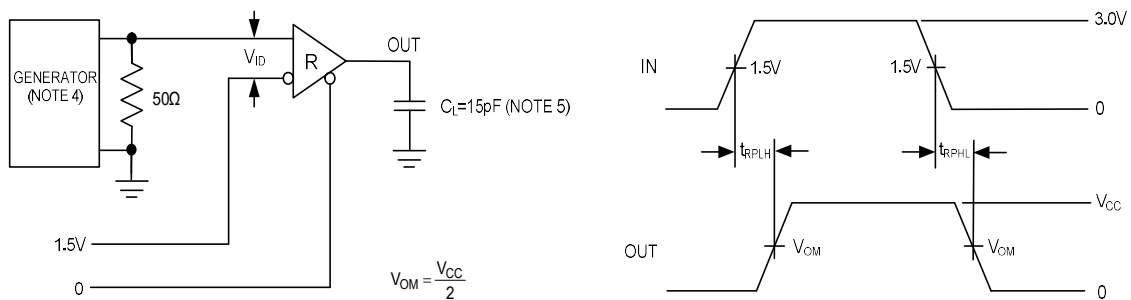

Figure 7. Receiver Propagation Delay

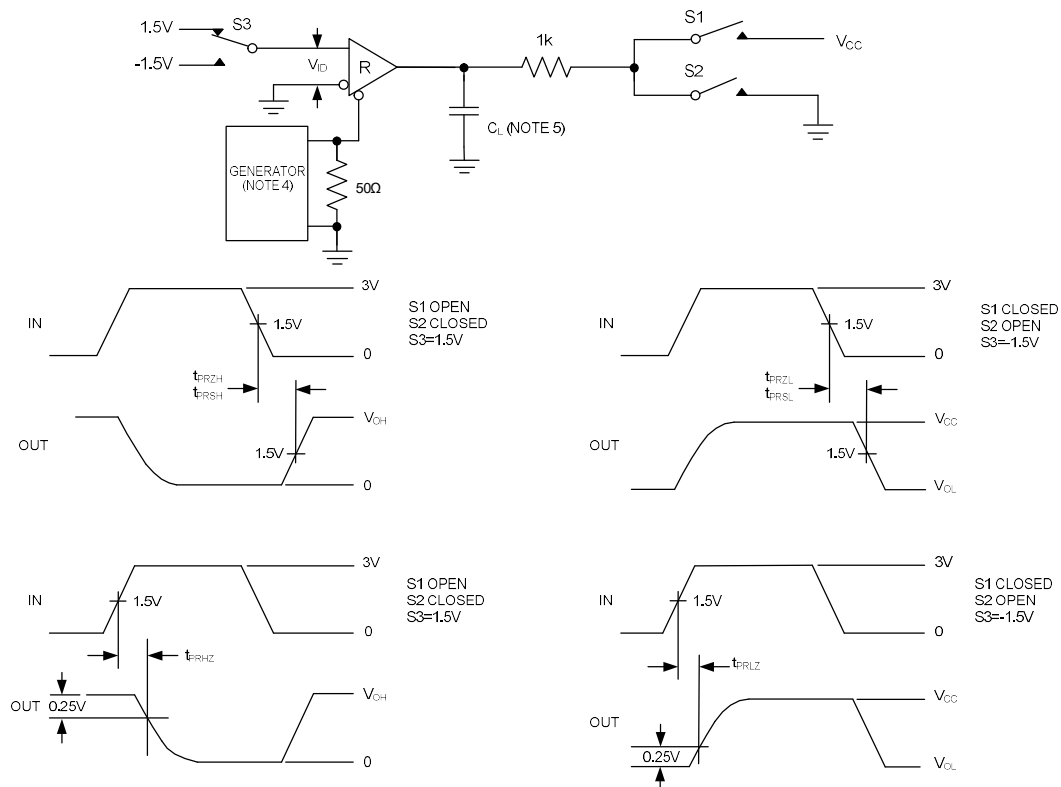

Figure 8. Receiver Enable and Disable Times

Note 4: The input pulse is supplied by a generator with the following characteristics: $f=250\text{kHz}$, 50% duty cycle, $t_r \leq 6.0\text{ns}$, $z_o=50\Omega$.

Note 5: C_L includes probe and stray capacitance.

Typical Operating Circuit

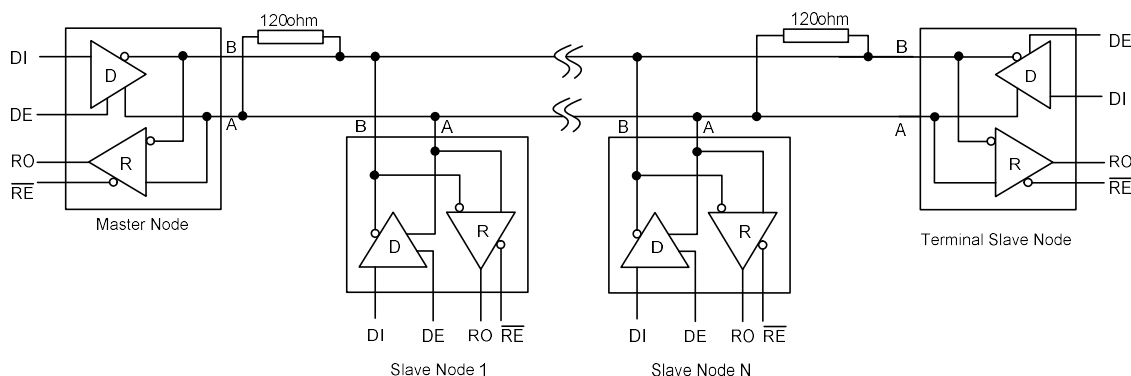

Figure 9. Typical Half-Duplex RS-485 Network

Detail Description

The UM3483E, UM3486E are low-power transceivers for RS-485 communications. The UM3483E can transmit and receive at data rates up to 500kbps, and the UM3486E at up to 2.5Mbps. The UM3483E, UM3486E are half-duplex. Driver Enable (DE) and Receiver Enable (\overline{RE}) pins are included on the UM3483E, UM3486E. When disabled, the driver and receiver outputs are high impedance.

Fail-Safe

The UM3483E, UM3486E guarantees a logic-high receiver output when the receiver inputs are shorted or open, or when they are connected to a terminated transmission line with all drivers disabled. This is done by setting the receiver threshold between -50mV and -200mV. If the differential receiver input voltage (A-B) is greater than or equal to -50mV, RO is logic high. If A-B is less than or equal to -200mV, RO is logic low. In the case of a terminated bus with all transmitters disabled, the receiver's differential input voltage is pulled to 0V by the termination. With the receiver thresholds of the UM3483E, UM3486E, this results in a logic high with a 50mV minimum noise margin. Unlike previous fail-safe devices, the -50mV to -200mV threshold complies with the $\pm 200\text{mV}$ EIA/TIA-485 standard.

$\pm 15\text{kV}$ ESD Protection

As with all Union devices, ESD-protection structures are incorporated on all pins to protect against electrostatic discharges encountered during handling and assembly. The driver outputs and receiver inputs of the UM3483E, UM3486E have extra protection against static electricity. Union's engineers have developed state-of-the-art structures to protect these pins against ESD of $\pm 15\text{kV}$ without damage. The ESD-protected pins are tested with reference to the ground pin in a power-down condition. They are tested to $\pm 15\text{kV}$ using the Human Body Model.

Applications Information

256 Transceivers on the Bus

The standard RS-485 receiver input impedance is $12\text{k}\Omega$ (one unit load), and the standard driver can drive up to 32 unit loads. The Union family of transceivers have a $1/8$ unit load receiver input impedance ($96\text{k}\Omega$), allowing up to 256 transceivers to be connected in parallel on one communication line. Any combination of these devices and/or other RS-485 transceivers with a total of 32 unit loads or less can be connected to the line.

Reduced EMI and Reflections

The UM3483E, UM3486E are slew-rate-limited, minimizing EMI and reducing reflections caused by improperly terminated cables. In general, a transmitter's rise time relates directly to the length of an unterminated stub, which can be driven with only minor waveform reflections. The following equation expresses this relationship conservatively:

$$\text{Length} = t_{\text{RISE}} / (10 \times 1.5 \text{ ns/ft})$$

Where t_{RISE} is the transmitter's rise time.

A system can work well with longer unterminated stubs, even with severe reflections, if the waveform settles out before the UART samples them.

Low-Power Shutdown Mode

Low-power shutdown mode is initiated by bringing both $\overline{\text{RE}}$ high and DE low. In shutdown, the device typically draws only 1 μ A of supply current. $\overline{\text{RE}}$ and DE may be driven simultaneously; the parts are guaranteed not to enter shutdown if $\overline{\text{RE}}$ is high and DE is low for less than 50ns. If the inputs are in this state for at least 600ns, the parts are guaranteed to enter shutdown. Enable times t_{PZH} and t_{PZL} in the Switching Characteristics tables assume the part was not in a low-power shutdown state. Enable times t_{PSH} and t_{PSL} assume the parts were shut down. It takes drivers and receivers longer to become enabled from low-power shutdown mode (t_{PSH} , t_{PSL}) than from driver/receiver-disable mode (t_{PZH} , t_{PZL}).

Driver Output Protection

Two mechanisms prevent excessive output current and power dissipation caused by faults or bus contention. First, a foldback current limit on the output stage, provides immediate protection against short circuits over the whole common-mode voltage range. Second, a thermal shutdown circuit, forces the driver outputs into a high-impedance state if the die temperature becomes excessive.

Propagation Delay

Skew time is simply the difference between the low-to-high and high-to-low propagation delay. Small driver/receiver skew times help maintain a symmetrical mark-space ratio (50% duty cycle). The receiver skew time, $|t_{\text{RPLH}} - t_{\text{RPHL}}|$, is under 10ns (20ns for the UM3483E). The driver skew times 12ns for the UM3486E, and typically under 50ns for the UM3483E.

Typical Applications

The UM3483E, UM3486E transceivers are designed for bidirectional data communications on multipoint bus transmission lines. To minimize reflections, the line should be terminated at both ends in its characteristic impedance, and stub lengths of the main line should be kept as short as possible. The slew-rate-limited UM3483E and the partially slew-rate-limited UM3486E are more tolerant of imperfect termination.

Package Information

SOP8

Outline Drawing

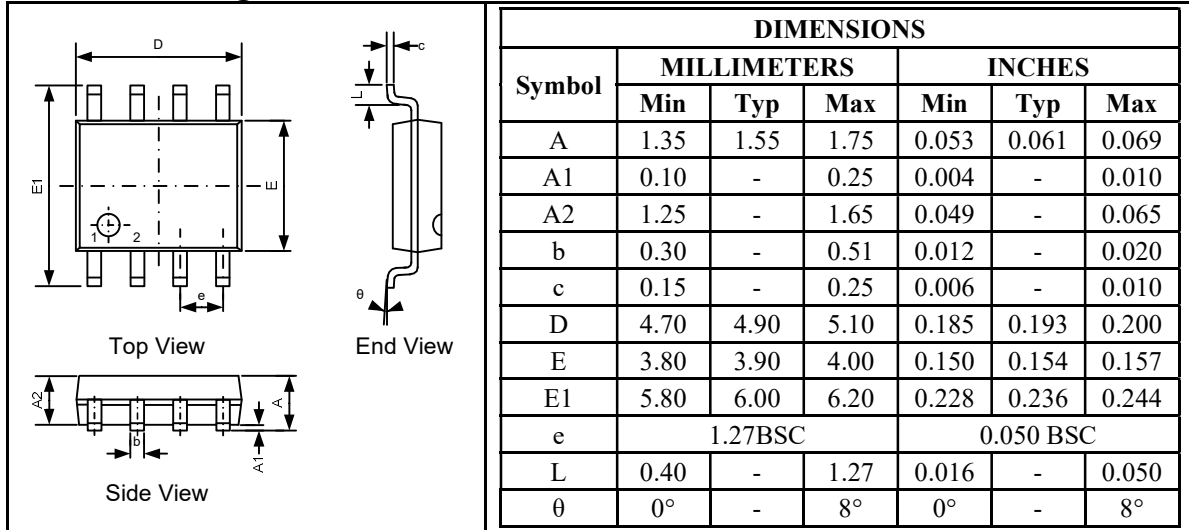

Land Pattern

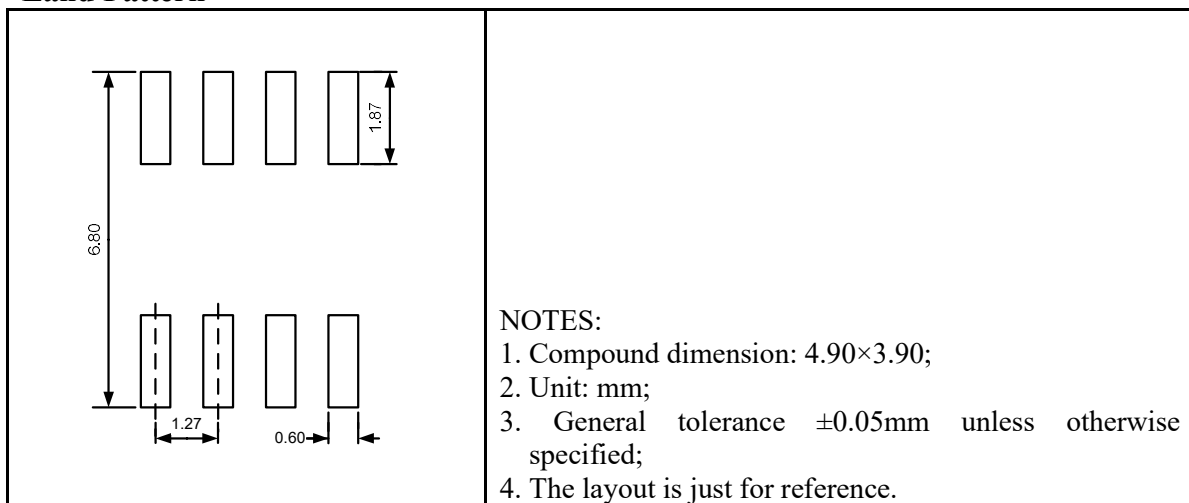

Tape and Reel Orientation



DIP8

Outline Drawing

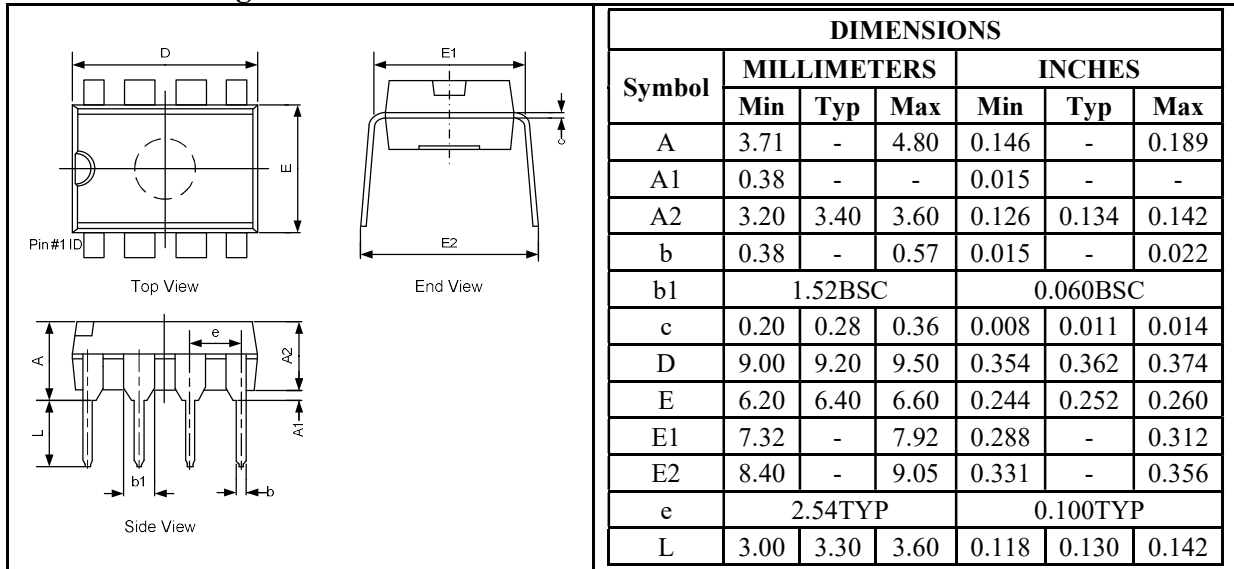

GREEN COMPLIANCE

Union Semiconductor is committed to environmental excellence in all aspects of its operations including meeting or exceeding regulatory requirements with respect to the use of hazardous substances. Numerous successful programs have been implemented to reduce the use of hazardous substances and/or emissions.

All Union components are compliant with the RoHS directive, which helps to support customers in their compliance with environmental directives. For more green compliance information, please visit:

http://www.union-ic.com/index.aspx?cat_code=RoHSDeclaration

IMPORTANT NOTICE

The information in this document has been carefully reviewed and is believed to be accurate. Nonetheless, this document is subject to change without notice. Union assumes no responsibility for any inaccuracies that may be contained in this document, and makes no commitment to update or to keep current the contained information, or to notify a person or organization of any update. Union reserves the right to make changes, at any time, in order to improve reliability, function or design and to attempt to supply the best product possible.



Union Semiconductor, Inc

Add: Unit 606, No.570 Shengxia Road, Shanghai 201210

Tel: 021-51093966

Fax: 021-51026018

Website: www.union-ic.com

Looking for pricing, stock, or lifecycle information?

Click below to explore more details on WIN SOURCE:

- ⊖ [View UM3486EESA on WIN SOURCE](#)
- ⊖ [Union Semiconductor](#) Information

Optimize Your Supply Chain with WIN SOURCE Solutions

- ✓ Global Sourcing Solution
- ✓ Obsolete Management
- ✓ Cost Control Management
- ✓ Shortage Management
- ✓ Alternative Solution
- ✓ Excess Inventory Management