

DATA SHEET

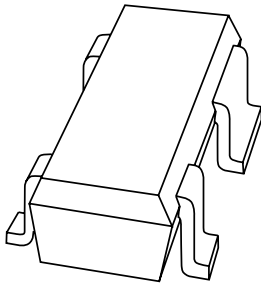

BGA2003 Silicon MMIC amplifier

Product specification
Supersedes data of 1999 Jul 23

2010 Sep 13



Silicon MMIC amplifier

BGA2003

FEATURES

- Low current
- Very high power gain
- Low noise figure
- Integrated temperature compensated biasing
- Control pin for adjustment bias current
- Supply and RF output pin combined.

APPLICATIONS

- RF front end
- Wideband applications, e.g. analog and digital cellular telephones, cordless telephones (PHS, DECT, etc.)
- Low noise amplifiers
- Satellite television tuners (SATV)
- High frequency oscillators.

DESCRIPTION

Silicon MMIC amplifier consisting of an NPN double polysilicon transistor with integrated biasing for low voltage applications in a plastic, 4-pin SOT343R package.

PINNING

PIN	DESCRIPTION
1	GND
2	RF in
3	CTRL (bias current control)
4	V _S + RF out

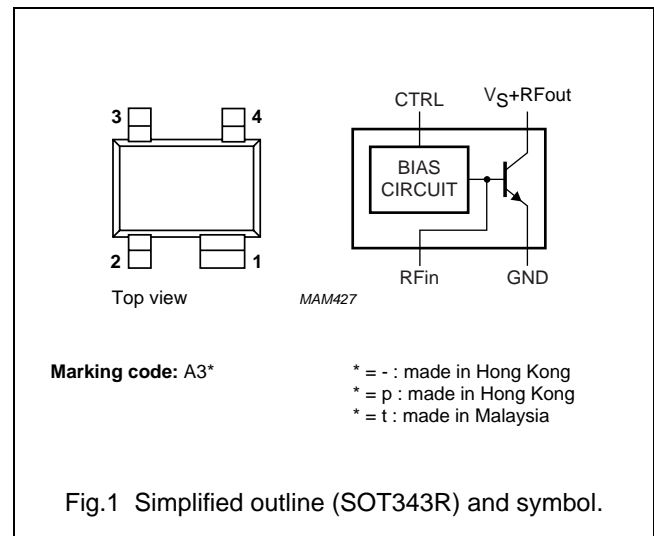

QUICK REFERENCE DATA

SYMBOL	PARAMETER	CONDITIONS	TYP.	MAX.	UNIT
V _S	DC supply voltage	RF input AC coupled	–	4.5	V
I _S	DC supply current	V _{V_S-OUT} = 2.5 V; I _{CTRL} = 1 mA; RF input AC coupled	11	–	mA
MSG	maximum stable gain	V _{V_S-OUT} = 2.5 V; f = 1800 MHz; T _{amb} = 25 °C	16	–	dB
NF	noise figure	V _{V_S-OUT} = 2.5 V; f = 1800 MHz; Γ _S = Γ _{opt}	1.8	–	dB

Silicon MMIC amplifier

BGA2003

LIMITING VALUES

In accordance with the Absolute Maximum Rating System (IEC 134).

SYMBOL	PARAMETER	CONDITIONS	MIN.	MAX.	UNIT
V_S	supply voltage	RF input AC coupled	–	4.5	V
V_{CTRL}	voltage on control pin		–	2	V
I_S	supply current (DC)	forced by DC voltage on RF input or I_{CTRL}	–	30	mA
I_{CTRL}	control current		–	3	mA
P_{tot}	total power dissipation	$T_s \leq 100\text{ °C}$	–	135	mW
T_{stg}	storage temperature		–65	+150	°C
T_j	operating junction temperature		–	150	°C

THERMAL CHARACTERISTICS

SYMBOL	PARAMETER	VALUE	UNIT
$R_{th\ j-s}$	thermal resistance from junction to soldering point	350	K/W

CHARACTERISTICSRF input AC coupled; $T_j = 25\text{ °C}$; unless otherwise specified.

SYMBOL	PARAMETER	CONDITIONS	MIN.	TYP.	MAX.	UNIT
I_S	supply current	$V_{VS-OUT} = 2.5\text{ V}$; $I_{CTRL} = 0.4\text{ mA}$	3	4.5	6	mA
		$V_{VS-OUT} = 2.5\text{ V}$; $I_{CTRL} = 1.0\text{ mA}$	8	11	15	mA
MSG	maximum stable gain	$V_{VS-OUT} = 2.5\text{ V}$; $I_{VS-OUT} = 10\text{ mA}$; $f = 900\text{ MHz}$	–	24	–	dB
		$V_{VS-OUT} = 2.5\text{ V}$; $I_{VS-OUT} = 10\text{ mA}$; $f = 1800\text{ MHz}$	–	16	–	dB
$ S_{21} ^2$	insertion power gain	$V_{VS-OUT} = 2.5\text{ V}$; $I_{VS-OUT} = 10\text{ mA}$; $f = 900\text{ MHz}$	18	19	–	dB
		$V_{VS-OUT} = 2.5\text{ V}$; $I_{VS-OUT} = 10\text{ mA}$; $f = 1800\text{ MHz}$	13	14	–	dB
S_{12}	isolation	$V_{VS-OUT} = 2.5\text{ V}$; $I_{VS-OUT} = 0$; $f = 900\text{ MHz}$	–	26	–	dB
		$V_{VS-OUT} = 2.5\text{ V}$; $I_{VS-OUT} = 0$; $f = 1800\text{ MHz}$	–	20	–	dB
NF	noise figure	$V_{VS-OUT} = 2.5\text{ V}$; $I_{VS-OUT} = 10\text{ mA}$; $f = 900\text{ MHz}$; $\Gamma_S = \Gamma_{opt}$	–	1.8	2	dB
		$V_{VS-OUT} = 2.5\text{ V}$; $I_{VS-OUT} = 10\text{ mA}$; $f = 1800\text{ MHz}$; $\Gamma_S = \Gamma_{opt}$	–	1.8	2	dB
IP3(in)	input intercept point; note 1	$V_{VS-OUT} = 2.3\text{ V}$; $I_{VS-OUT} = 3.6\text{ mA}$; $f = 900\text{ MHz}$	–	–6.5	–	dBm
		$V_{VS-OUT} = 2.3\text{ V}$; $I_{VS-OUT} = 3.5\text{ mA}$; $f = 1800\text{ MHz}$	–	–4.8	–	dBm

Note

- See application note RNR-T45-99-B-0514.

Silicon MMIC amplifier

BGA2003

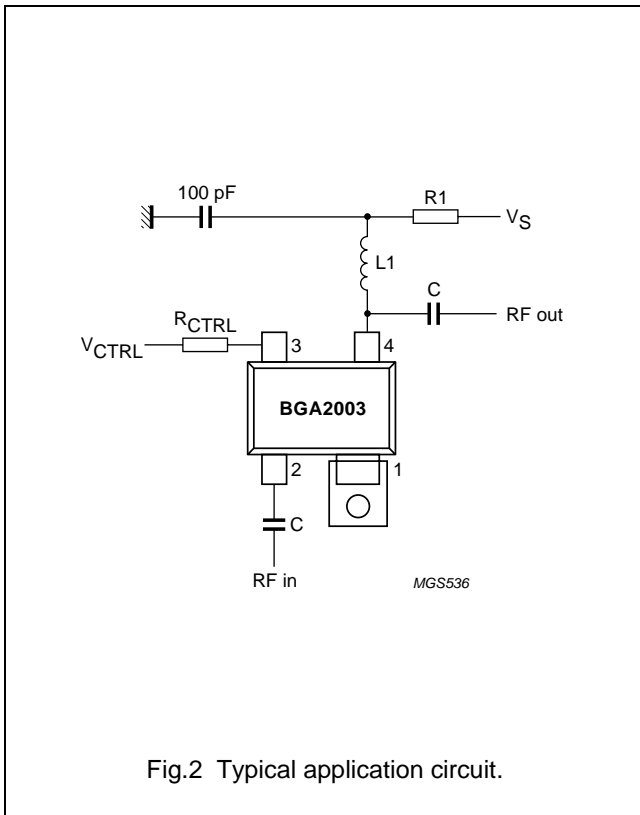

Fig.2 Typical application circuit.

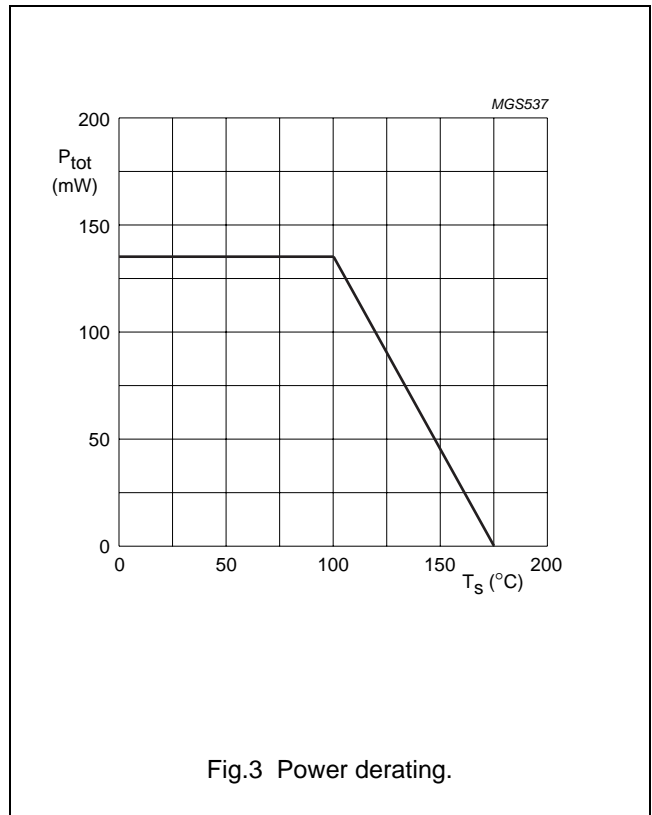
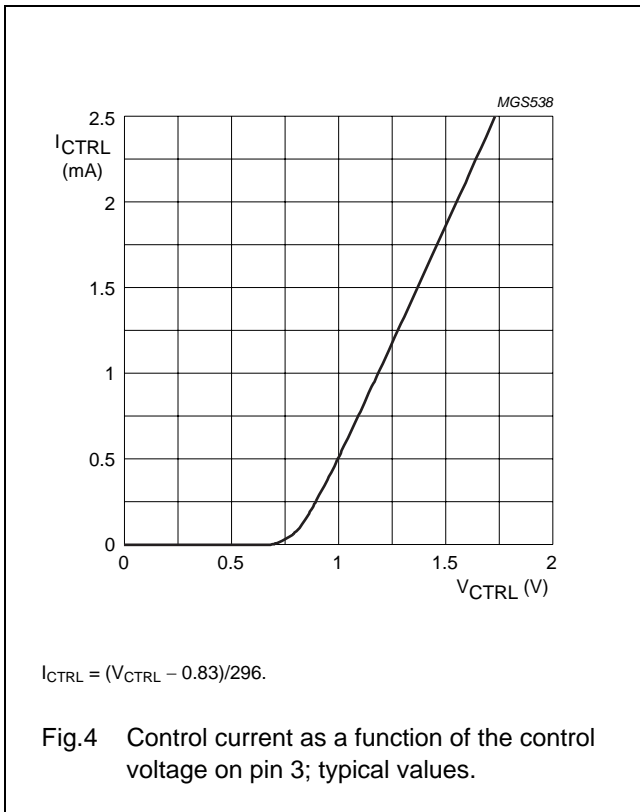
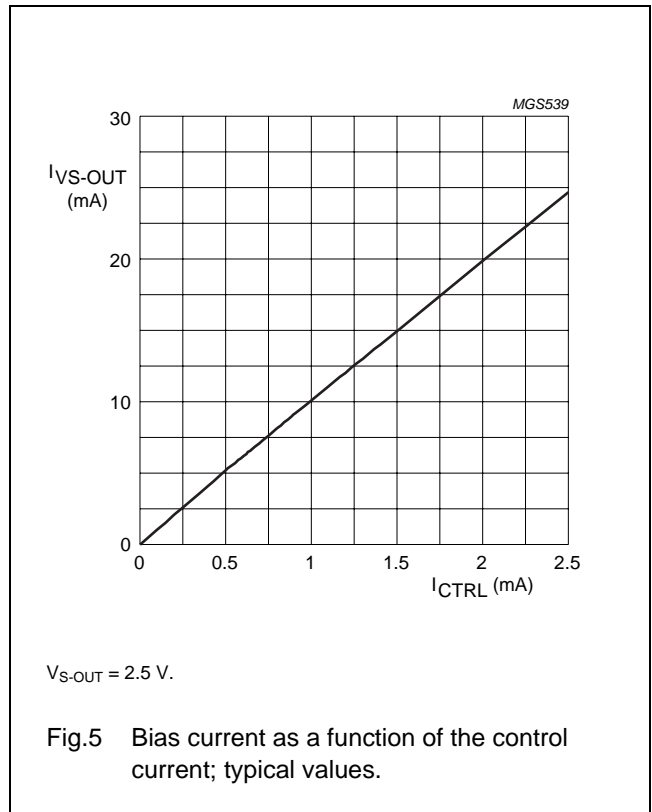

Fig.3 Power derating.



$$I_{CTRL} = (V_{CTRL} - 0.83)/296.$$

Fig.4 Control current as a function of the control voltage on pin 3; typical values.



$$V_{S-OUT} = 2.5 \text{ V.}$$

Fig.5 Bias current as a function of the control current; typical values.

Silicon MMIC amplifier

BGA2003

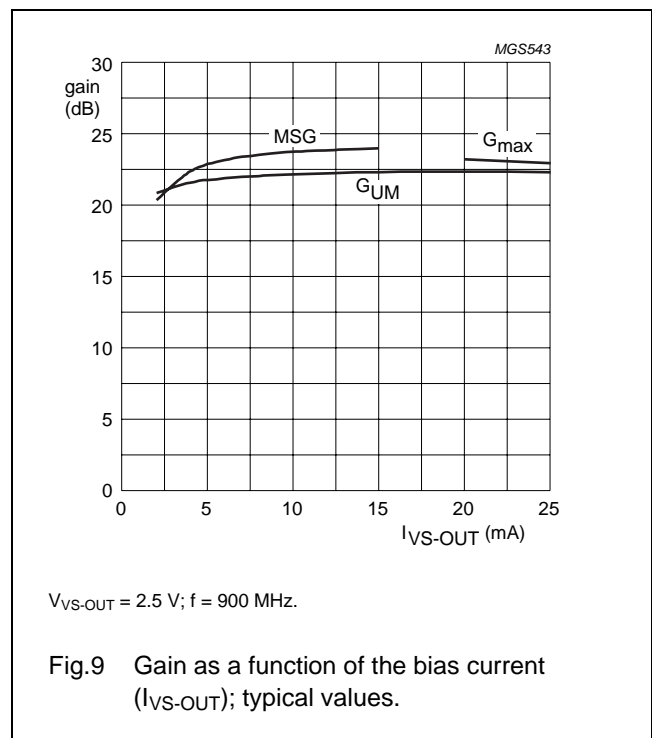
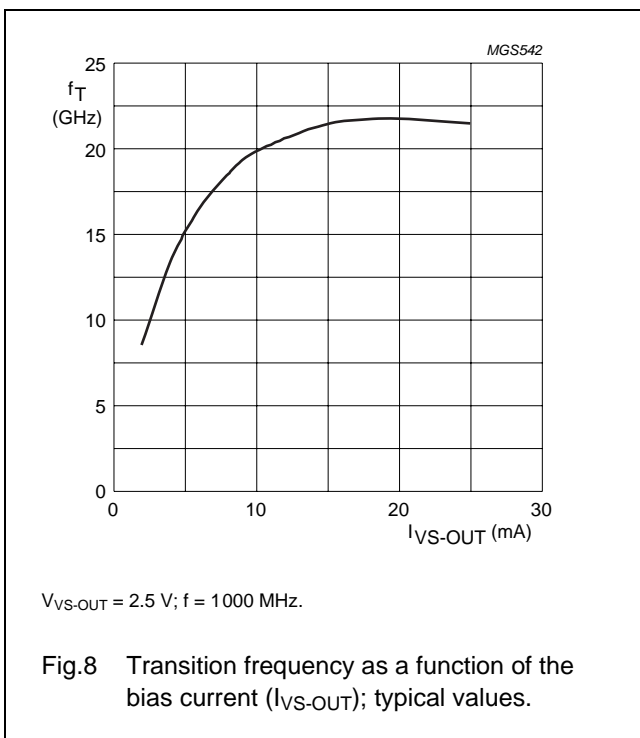
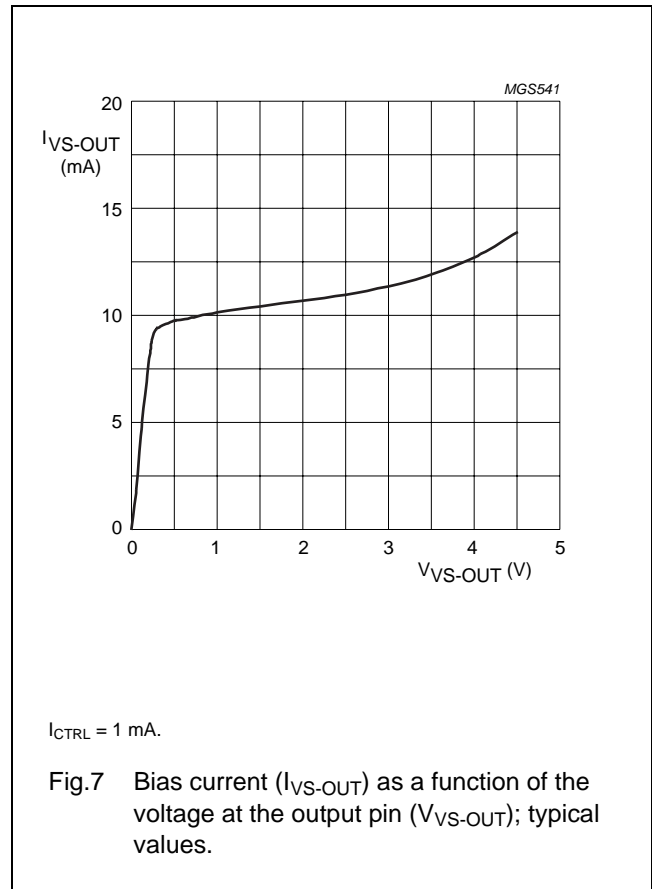
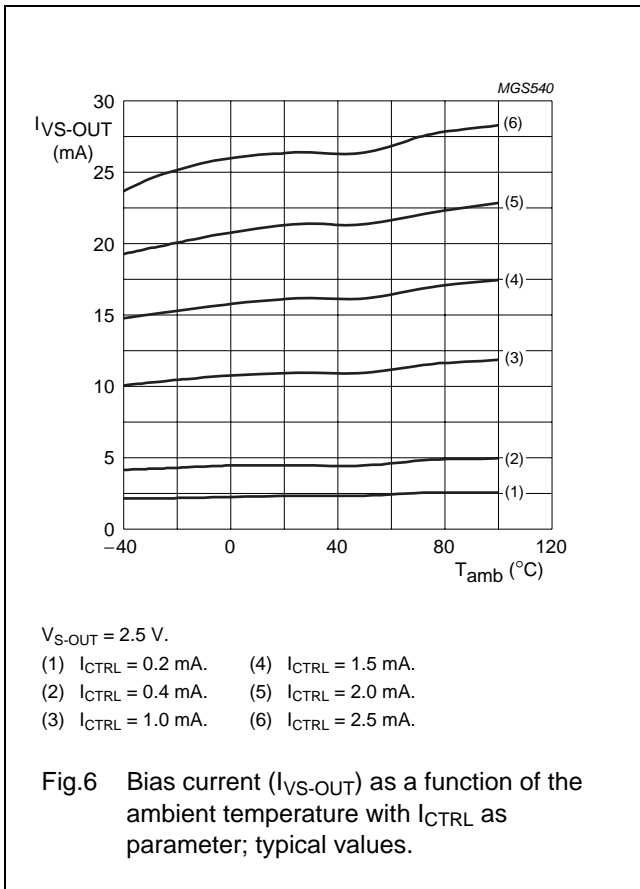

Silicon MMIC amplifier

BGA2003

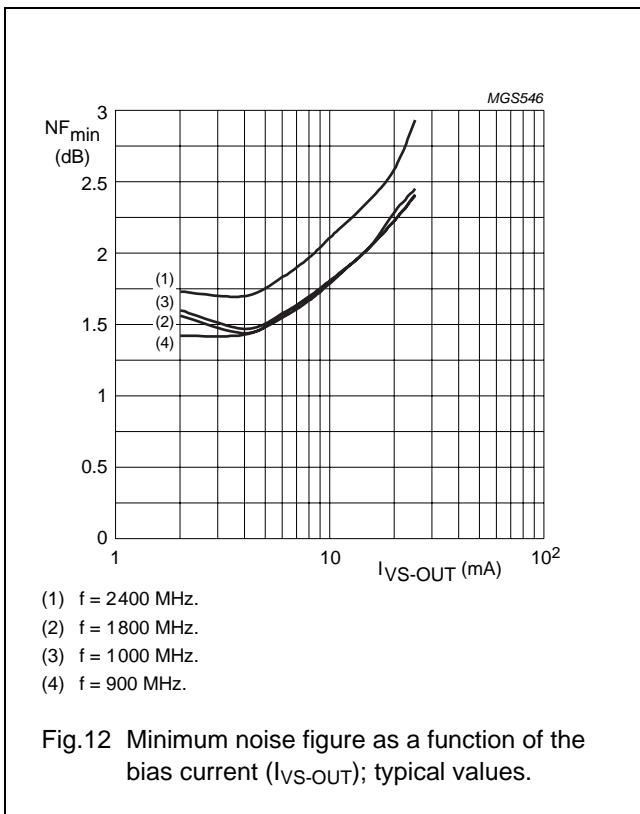
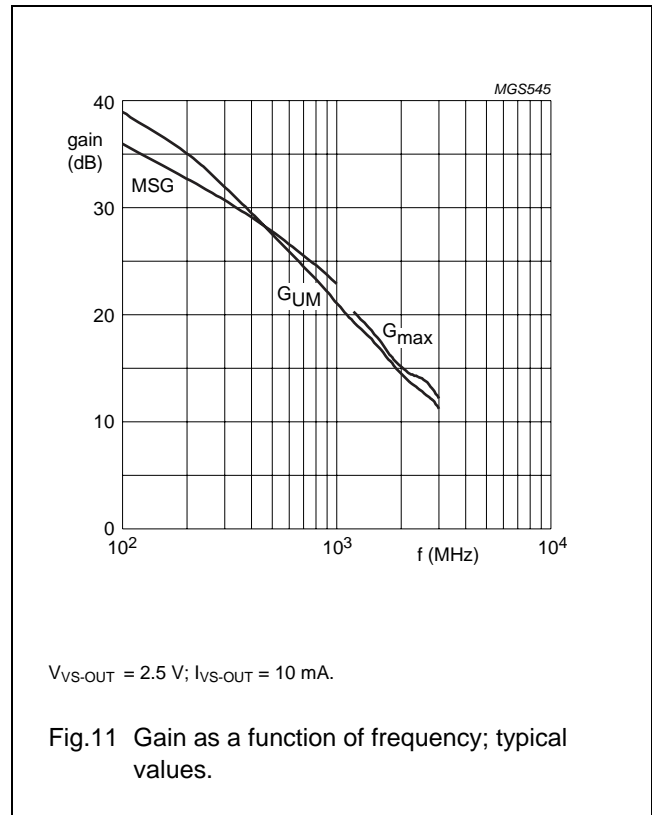
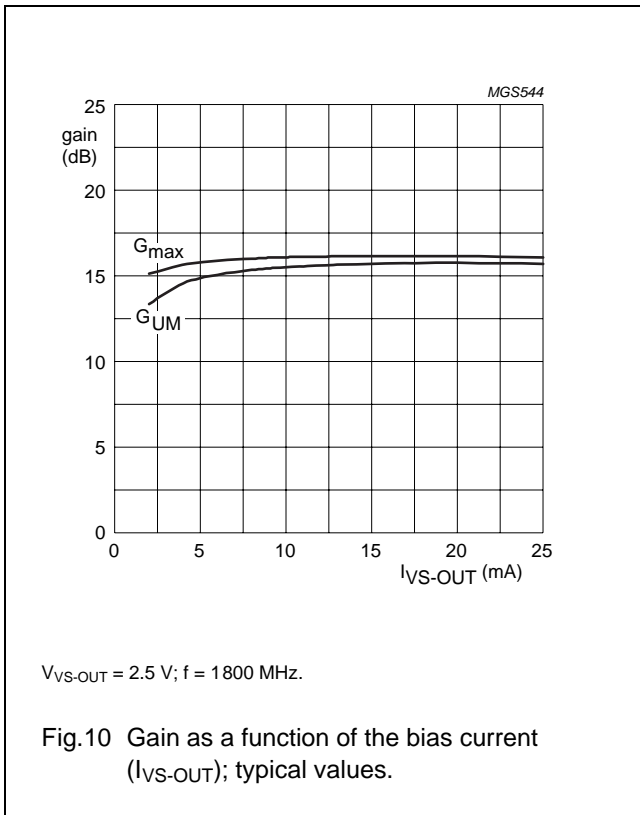

Silicon MMIC amplifier

BGA2003

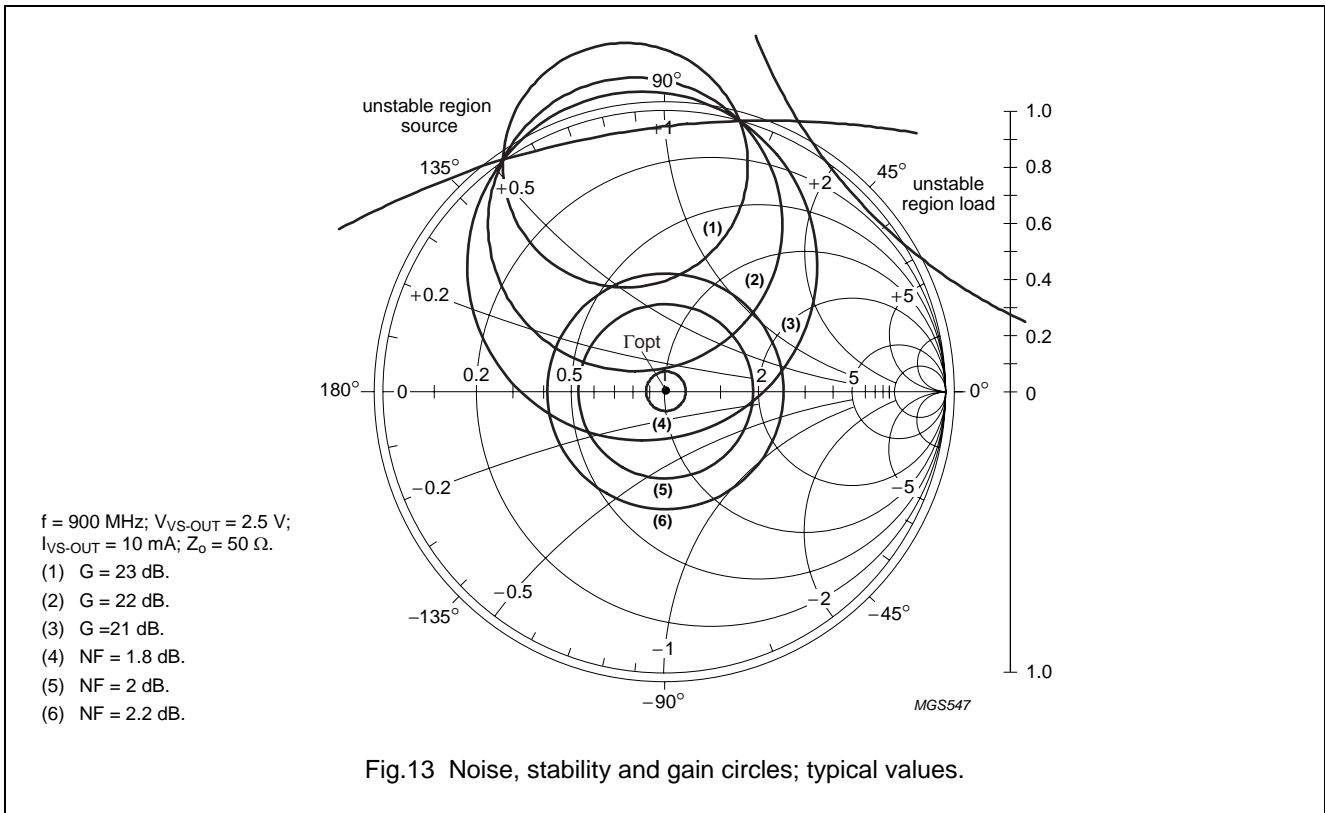

Fig.13 Noise, stability and gain circles; typical values.

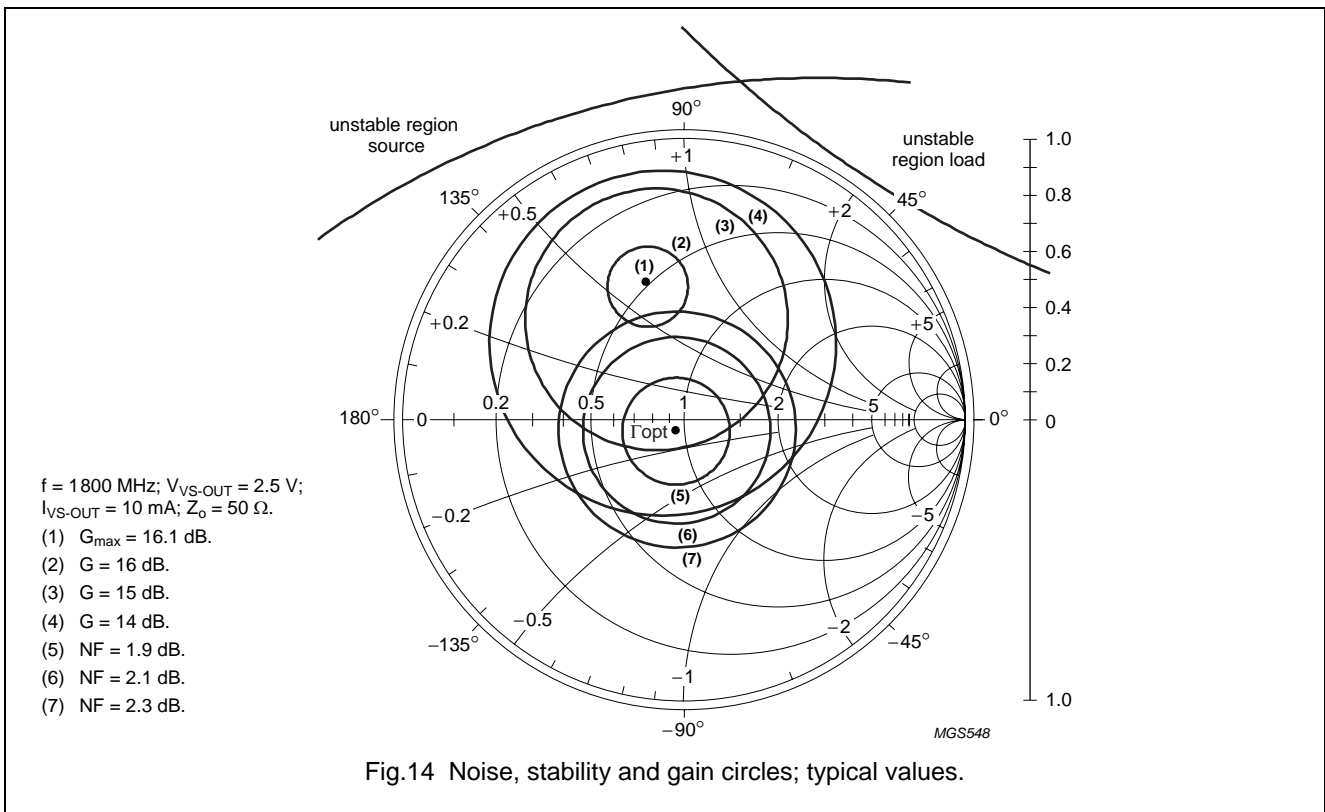

Fig.14 Noise, stability and gain circles; typical values.

Silicon MMIC amplifier

BGA2003

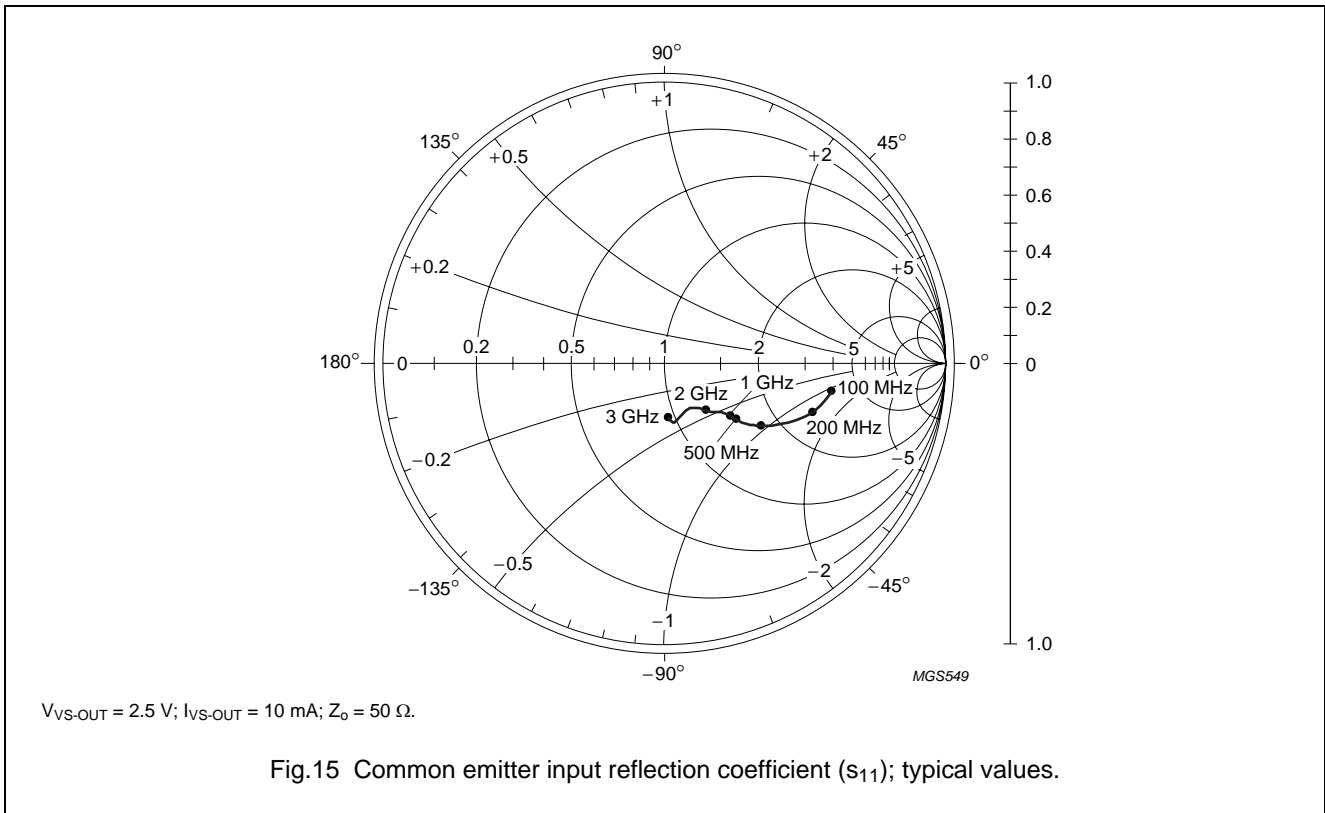

Fig.15 Common emitter input reflection coefficient (s_{11}); typical values.

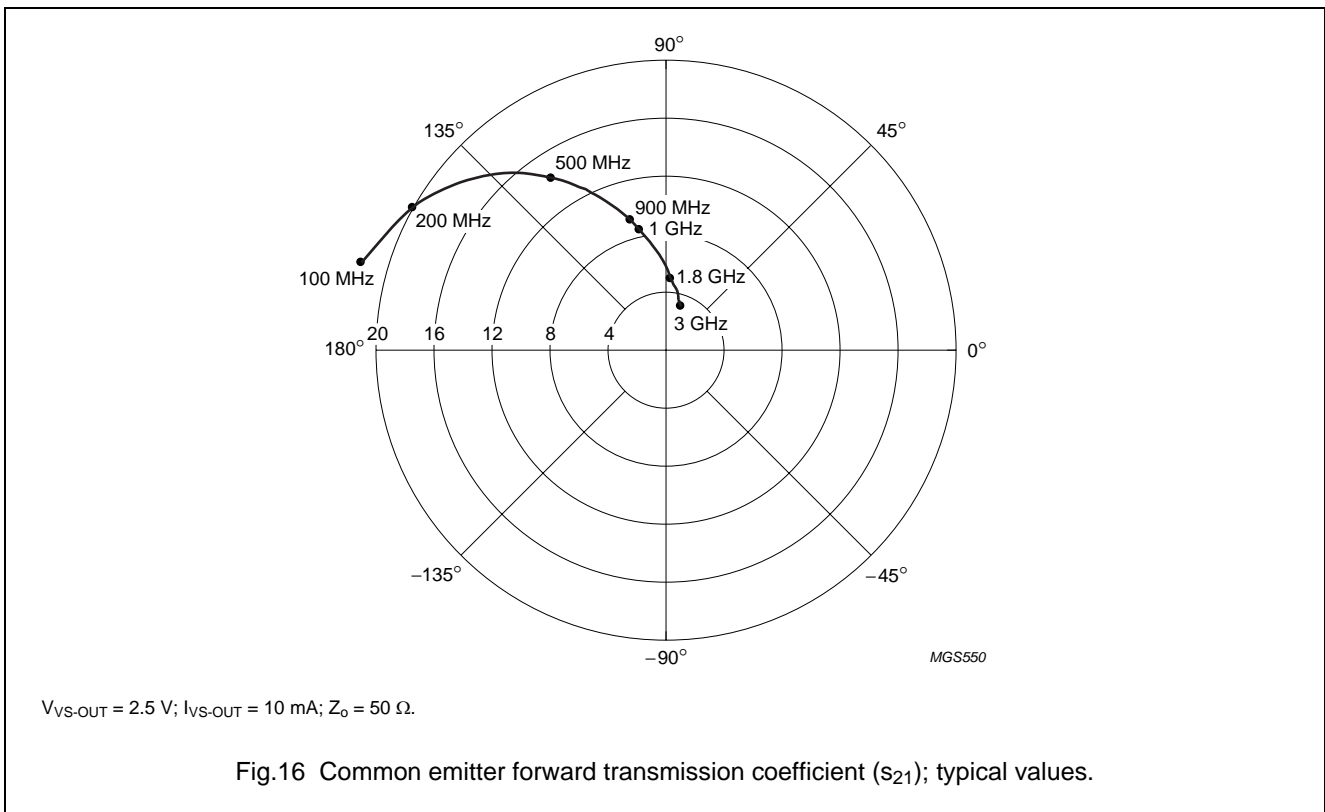
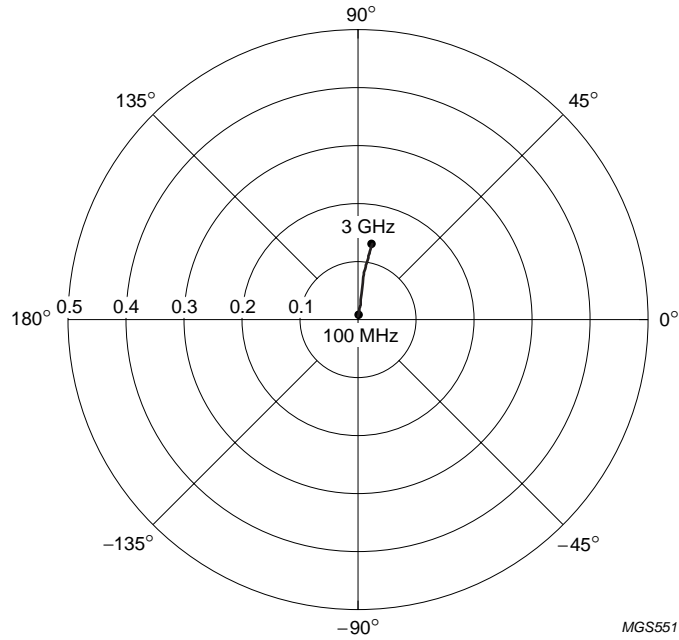

Fig.16 Common emitter forward transmission coefficient (s_{21}); typical values.

Silicon MMIC amplifier

BGA2003



$V_{VS-OUT} = 2.5\text{ V}$; $I_{VS-OUT} = 10\text{ mA}$; $Z_o = 50\ \Omega$.

Fig.17 Common emitter reverse transmission coefficient (s_{12}); typical values.

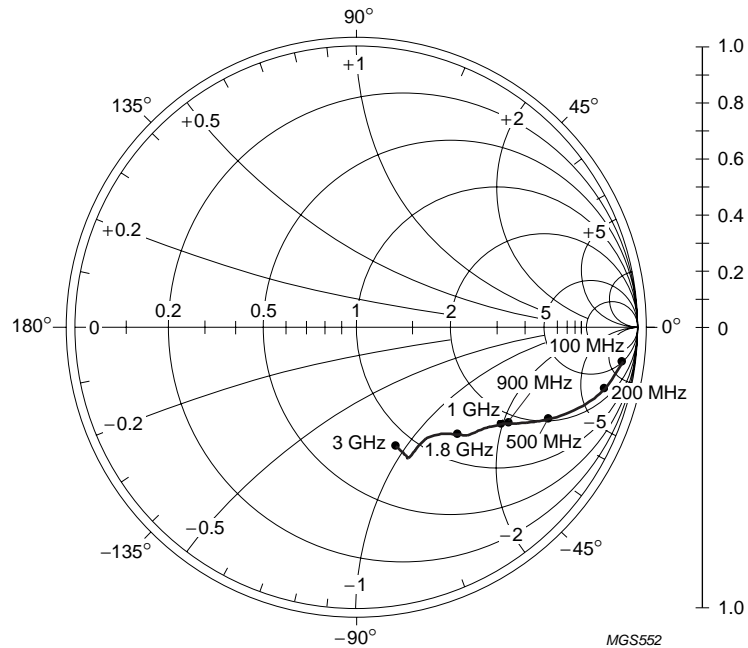

$V_{VS-OUT} = 2.5\text{ V}$; $I_{VS-OUT} = 10\text{ mA}$; $Z_o = 50\ \Omega$.

Fig.18 Common emitter output reflection coefficient (s_{22}); typical values.

Silicon MMIC amplifier

BGA2003

PACKAGE OUTLINE

Plastic surface-mounted package; reverse pinning; 4 leads

SOT343R

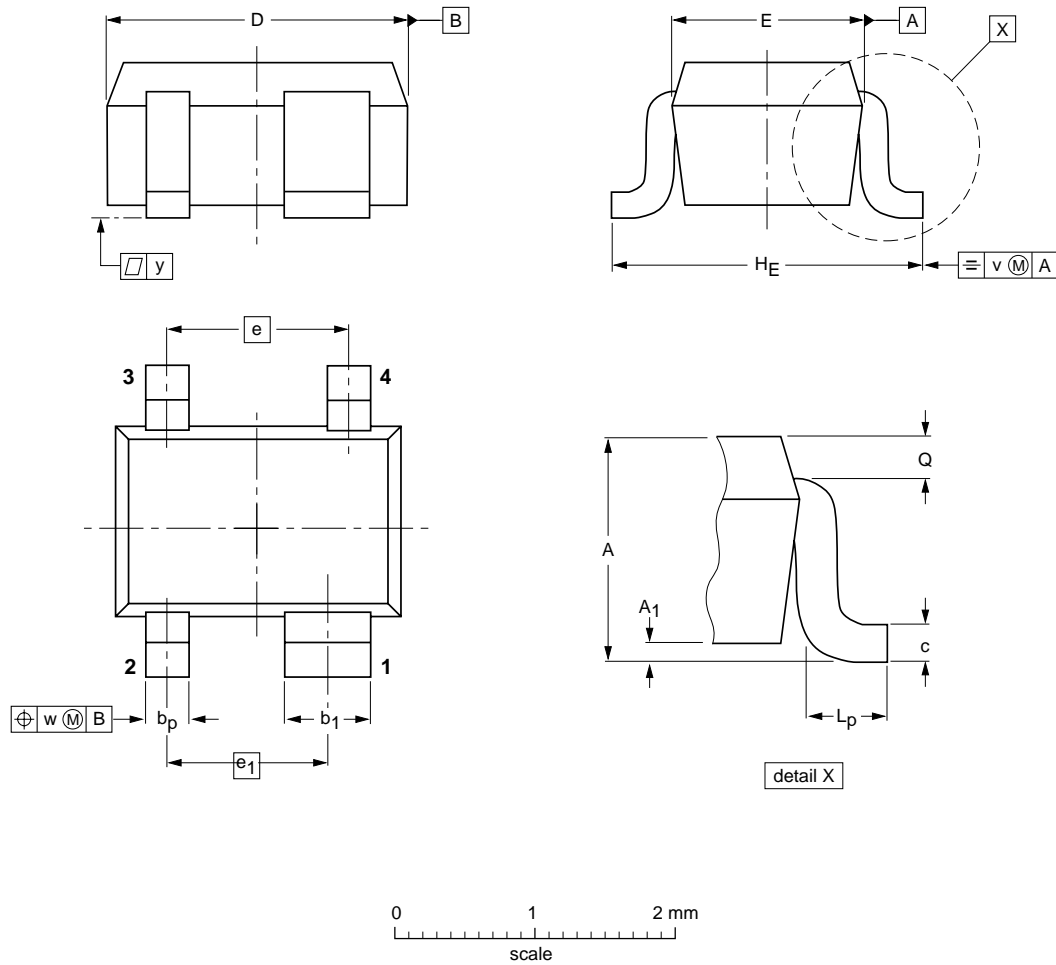

DIMENSIONS (mm are the original dimensions)

UNIT	A	A ₁ max	b _p	b ₁	c	D	E	e	e ₁	H _E	L _p	Q	v	w	y
mm	1.1 0.8	0.1	0.4 0.3	0.7 0.5	0.25 0.10	2.2 1.8	1.35 1.15	1.3	1.15	2.2 2.0	0.45 0.15	0.23 0.13	0.2	0.2	0.1

OUTLINE VERSION	REFERENCES				EUROPEAN PROJECTION	ISSUE DATE
	IEC	JEDEC	EIAJ			
SOT343R						97-05-21 06-03-16

Silicon MMIC amplifier

BGA2003

DATA SHEET STATUS

DOCUMENT STATUS ⁽¹⁾	PRODUCT STATUS ⁽²⁾	DEFINITION
Objective data sheet	Development	This document contains data from the objective specification for product development.
Preliminary data sheet	Qualification	This document contains data from the preliminary specification.
Product data sheet	Production	This document contains the product specification.

Notes

1. Please consult the most recently issued document before initiating or completing a design.
2. The product status of device(s) described in this document may have changed since this document was published and may differ in case of multiple devices. The latest product status information is available on the Internet at URL <http://www.nxp.com>.

DISCLAIMERS

Limited warranty and liability — Information in this document is believed to be accurate and reliable. However, NXP Semiconductors does not give any representations or warranties, expressed or implied, as to the accuracy or completeness of such information and shall have no liability for the consequences of use of such information.

In no event shall NXP Semiconductors be liable for any indirect, incidental, punitive, special or consequential damages (including - without limitation - lost profits, lost savings, business interruption, costs related to the removal or replacement of any products or rework charges) whether or not such damages are based on tort (including negligence), warranty, breach of contract or any other legal theory.

Notwithstanding any damages that customer might incur for any reason whatsoever, NXP Semiconductors' aggregate and cumulative liability towards customer for the products described herein shall be limited in accordance with the *Terms and conditions of commercial sale* of NXP Semiconductors.

Right to make changes — NXP Semiconductors reserves the right to make changes to information published in this document, including without limitation specifications and product descriptions, at any time and without notice. This document supersedes and replaces all information supplied prior to the publication hereof.

Suitability for use — NXP Semiconductors products are not designed, authorized or warranted to be suitable for use in life support, life-critical or safety-critical systems or equipment, nor in applications where failure or malfunction of an NXP Semiconductors product can reasonably be expected to result in personal injury, death or severe

property or environmental damage. NXP Semiconductors accepts no liability for inclusion and/or use of NXP Semiconductors products in such equipment or applications and therefore such inclusion and/or use is at the customer's own risk.

Applications — Applications that are described herein for any of these products are for illustrative purposes only. NXP Semiconductors makes no representation or warranty that such applications will be suitable for the specified use without further testing or modification.

Customers are responsible for the design and operation of their applications and products using NXP Semiconductors products, and NXP Semiconductors accepts no liability for any assistance with applications or customer product design. It is customer's sole responsibility to determine whether the NXP Semiconductors product is suitable and fit for the customer's applications and products planned, as well as for the planned application and use of customer's third party customer(s). Customers should provide appropriate design and operating safeguards to minimize the risks associated with their applications and products.

NXP Semiconductors does not accept any liability related to any default, damage, costs or problem which is based on any weakness or default in the customer's applications or products, or the application or use by customer's third party customer(s). Customer is responsible for doing all necessary testing for the customer's applications and products using NXP Semiconductors products in order to avoid a default of the applications and the products or of the application or use by customer's third party customer(s). NXP does not accept any liability in this respect.

Silicon MMIC amplifier

BGA2003

Limiting values — Stress above one or more limiting values (as defined in the Absolute Maximum Ratings System of IEC 60134) will cause permanent damage to the device. Limiting values are stress ratings only and (proper) operation of the device at these or any other conditions above those given in the Recommended operating conditions section (if present) or the Characteristics sections of this document is not warranted. Constant or repeated exposure to limiting values will permanently and irreversibly affect the quality and reliability of the device.

Terms and conditions of commercial sale — NXP Semiconductors products are sold subject to the general terms and conditions of commercial sale, as published at <http://www.nxp.com/profile/terms>, unless otherwise agreed in a valid written individual agreement. In case an individual agreement is concluded only the terms and conditions of the respective agreement shall apply. NXP Semiconductors hereby expressly objects to applying the customer's general terms and conditions with regard to the purchase of NXP Semiconductors products by customer.

No offer to sell or license — Nothing in this document may be interpreted or construed as an offer to sell products that is open for acceptance or the grant, conveyance or implication of any license under any copyrights, patents or other industrial or intellectual property rights.

Export control — This document as well as the item(s) described herein may be subject to export control regulations. Export might require a prior authorization from national authorities.

Quick reference data — The Quick reference data is an extract of the product data given in the Limiting values and Characteristics sections of this document, and as such is not complete, exhaustive or legally binding.

Non-automotive qualified products — Unless this data sheet expressly states that this specific NXP Semiconductors product is automotive qualified, the product is not suitable for automotive use. It is neither qualified nor tested in accordance with automotive testing or application requirements. NXP Semiconductors accepts no liability for inclusion and/or use of non-automotive qualified products in automotive equipment or applications.

In the event that customer uses the product for design-in and use in automotive applications to automotive specifications and standards, customer (a) shall use the product without NXP Semiconductors' warranty of the product for such automotive applications, use and specifications, and (b) whenever customer uses the product for automotive applications beyond NXP Semiconductors' specifications such use shall be solely at customer's own risk, and (c) customer fully indemnifies NXP Semiconductors for any liability, damages or failed product claims resulting from customer design and use of the product for automotive applications beyond NXP Semiconductors' standard warranty and NXP Semiconductors' product specifications.

NXP Semiconductors

provides High Performance Mixed Signal and Standard Product solutions that leverage its leading RF, Analog, Power Management, Interface, Security and Digital Processing expertise

Customer notification

This data sheet was changed to reflect the new company name NXP Semiconductors, including new legal definitions and disclaimers. No changes were made to the technical content, except for the marking codes and the package outline drawings which were updated to the latest version.

Contact information

For additional information please visit: <http://www.nxp.com>

For sales offices addresses send e-mail to: salesaddresses@nxp.com



© NXP B.V. 2010

All rights are reserved. Reproduction in whole or in part is prohibited without the prior written consent of the copyright owner.

The information presented in this document does not form part of any quotation or contract, is believed to be accurate and reliable and may be changed without notice. No liability will be accepted by the publisher for any consequence of its use. Publication thereof does not convey nor imply any license under patent- or other industrial or intellectual property rights.

Looking for pricing, stock, or lifecycle information?

Click below to explore more details on WIN SOURCE:

-  [View BGA2003,115 on WIN SOURCE](#)
-  [NXP / Nexperia Information](#)

Optimize Your Supply Chain with WIN SOURCE Solutions

-  Global Sourcing Solution
-  Obsolete Management
-  Cost Control Management
-  Shortage Management
-  Alternative Solution
-  Excess Inventory Management